

Information Bulletin

Clarification of Arc-Fault Circuits



Arc-Fault Circuit Interrupter (AFCI) protection has been required in the Canadian Electrical Code, Manitoba Electrical Code and the Winnipeg Electrical Bylaw to varying degrees since 2003. Since that time, the Code requirements for arc-fault protection have expanded from sleeping rooms only to virtually the entire dwelling unit. With the expansion of the Rule many questions have surfaced regarding where arc-fault protection should be applied and what is exempt. This bulletin aims to clarify those requirements.



Code requirements and exceptions

Manitoba Electrical Code (MEC) Rule 26-658 states that each branch circuit for dwelling units supplying 125 Volt receptacles rated at 20 Amps or less must be protected by an arc-fault circuit interrupter (AFCI) except for the following:

1. Receptacles in bathrooms and washrooms provided no other receptacles are connected to the circuit(s).
2. Kitchen counter, island and peninsula receptacles.
3. Kitchen refrigerator receptacles.
4. A sump pump receptacle when a single receptacle is permanently labeled for the sump pump only and is on a separate circuit feeding no other receptacles.

Detached structures

Receptacles for detached garages, sheds and other outbuildings and receptacles mounted on fence posts and on other standalone exterior structures are not considered as part of the dwelling unit so are not required to be AFCI protected.

Clarification of circuits requiring AFCI protection

All 15 and 20 Amp receptacles rated at 125 Volts located in or on a dwelling and not included in the above exceptions must be provided with arc-fault protection. This includes:

- Receptacles mounted under sinks and in cupboards for specific appliances such as garburators, dishwashers, switched low voltage lighting, etc.
- Switched receptacles, e.g.: in soffits, living rooms, bedrooms, etc.
- Bar and laundry counter receptacles.
- Receptacles for basement fridges and fridges in locations other than the kitchen.
- Receptacles for appliances such as freezers, microwaves, washing machines, gas ranges, central vacuum systems, etc.
- Receptacles for HRV systems.

- The utility room/unfinished basement receptacle (often located adjacent to the panel).
- Receptacles in attached garages including those for overhead garage door openers.
- All exterior receptacles mounted on the dwelling or on an attached garage including those in, on or for the porch, balcony, deck, yard appliances, and driveway receptacles.

Methods of AFCI protection

Currently, there are two acceptable options to provide arc-fault protection for a branch circuit:

- an arc-fault circuit breaker, or
- an arc-fault receptacle.



If employing an arc-fault circuit breaker, it must be a “combination-type.” See below for additional information.

If employing an arc-fault receptacle, it must be installed as the first receptacle of the branch circuit and the wiring between the overcurrent device (circuit breaker or fuse) and the arc-fault receptacle

must be protected by metal raceway, armoured cable (BX/AC90 or TECK), or non-metallic conduit or tubing.



Combination-type AFCI protection

Since October 1, 2015, arc-fault protection has been required to be combination-type i.e.: provide both series and parallel arc-fault protection. While all outlet branch-circuit-type arc-fault circuit interrupters (e.g.: AFCI receptacles) provide both series and parallel arc-fault protection, some AFCI breakers do not. Care should be taken to ensure only combination-type AFCI breakers are being installed. They must be labelled as “Combination AFCI,” “CAFI” or “CAFCI.” Non-combination-type arc-fault breakers may be susceptible to nuisance tripping.

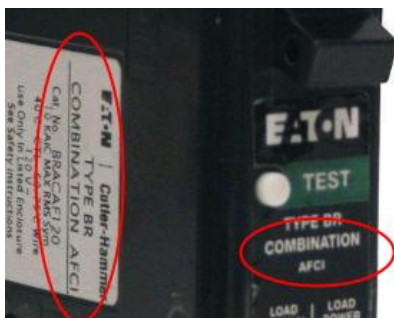

Sample labels on combination-type AFCI breakers

The above requirements are applicable to all new installations.

AFCI applications to existing circuits

Existing receptacle circuits for dwelling units that were not required to have AFCI protection upon installation¹ are not required to be AFCI protected unless the circuit wiring is being replaced, such as when replacing knob & tube wiring. However, electrical Code requirements apply to all new installations including extensions or alterations to existing circuits. These installations may have some unique challenges that are not addressed in the Code but that are clarified below.

Adding new receptacles to an existing circuit

When an existing circuit is being extended or altered to provide additional receptacles for the dwelling unit, the new receptacle(s) must be arc-fault protected. One method to providing arc-fault protection to an existing circuit is to replace the existing circuit breaker with a combination-type arc-fault breaker. With this method, the entire circuit is protected including the existing wiring and the existing devices.

The above method is acceptable however MEC Item 26-658 c) allows provision of AFCI protection to be limited to only the newly installed receptacle(s) when an “outlet branch-circuit-type arc-fault circuit interrupter” (e.g.: AFCI receptacle) is utilized. When using this option, replacing the last existing receptacle on the circuit with a new AFCI receptacle provides AFCI protection to all downstream (i.e.: new) devices. See diagram below:

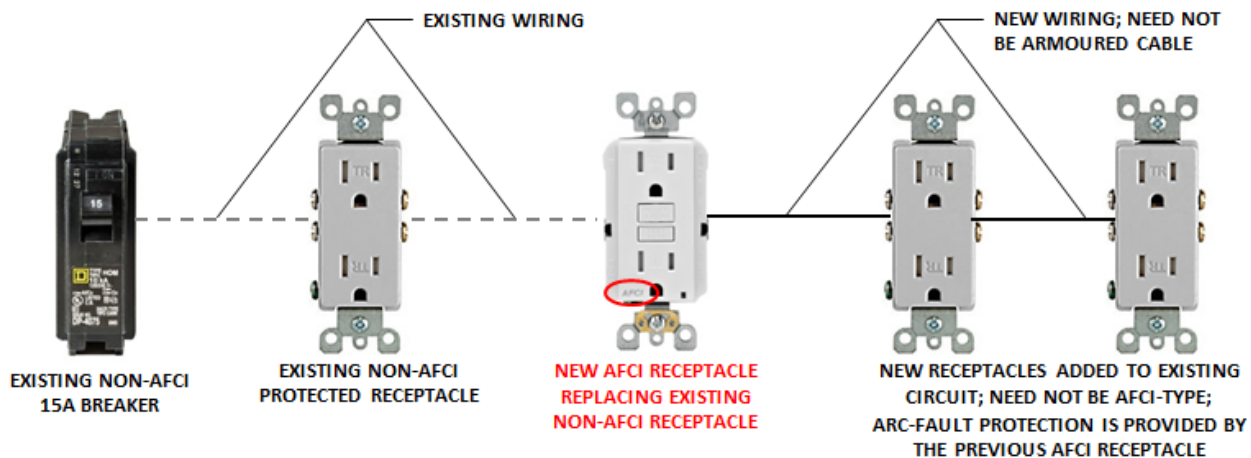

Existing circuits with smoke and/or CO alarms or heat sensors

Caution should be exercised when providing AFCI protection for an existing receptacle circuit to ensure that existing hard-wired smoke and CO alarms are not wired to any of the extended/altere d circuits unless the smoke/CO alarms are provided with battery back-up. Furthermore, if the attached garage heat sensor is connected to the smoke alarm circuit, it must not be connected to an AFCI or GFCI protected circuit as approved heat sensors are not available with battery back-up at this time.

Existing circuits with ungrounded receptacles



When adding receptacles to circuits where a Ground Fault Circuit Interrupter (GFCI) was installed to accommodate the replacement of 2-prong (ungrounded) receptacles with 3-prong (grounded) receptacles, a Dual Function Circuit Interrupter (DFCI) must be installed. When a new receptacle is being added to such a circuit, a DFCI will meet both the arc-fault requirements of MEC Rule 26-658, and the GFCI requirements of MEC Subrule 26-702(2), where the ungrounded wiring must be GFCI protected

when replacing ungrounded receptacles with the grounded type. If the AFCI/GFCI protection is being provided via installation of a DFCI receptacle, the wiring between the circuit breaker and the DFCI receptacle must be protected by metal raceway, armoured cable (BX/AC90 or TECK), or non-metallic conduit or tubing.



Use of “dead front” or “blank face” AFCI devices

Where installing a new receptacle for an appliance that requires a dedicated circuit breaker (e.g.: a microwave, wash machine, etc.), a “dead front” or “blank face” AFCI device will be accepted as suitable AFCI protection where it is demonstrated that an AFCI circuit breaker from the panel manufacturer is not available or where the existing panel doesn’t afford the space required for an AFCI breaker.

The “dead front” or “blank face” AFCI device must be installed adjacent to the panel, the wiring between the overcurrent device (circuit breaker or fuse) and the “dead front/blank face” AFCI must be metal raceway, armoured cable, or non-metallic conduit or tubing and the device must be permanently labelled as to the appliance it protects. Note that for this scenario, use of an AFCI receptacle in lieu of the “dead front” AFCI device is not acceptable because the appliance is required to be on a dedicated circuit supplying no other receptacles. “Dead front/blank face” AFCI devices are not permissible for new construction.



Service upgrades & panel replacements

If upgrading the electrical service or replacing the panel only, installation of arc-fault protection for the existing receptacle circuits is encouraged but not enforced. If adding an additional receptacle circuit, arc-fault protection is required for that circuit per the MEC and the above clarifications.

All above Code references relate to the 2024 MEC.

ⁱ Existing receptacle circuits must have been installed under permit and meeting the Code requirements enforced at the time of installation. Regarding AFCI requirements, receptacle circuits not requiring arc-fault protection upon installation consist of the following:

- All receptacle circuits installed prior to April 1, 2003,*
- Receptacle circuits other than sleeping room circuits installed between April 1, 2003* and September 30, 2015,* inclusive and
- Receptacle circuits other than sleeping room circuits and those supplying single receptacles installed for stationary appliances such as microwaves, washing machines, freezers, gas ranges, central vacuum systems, HRVs, O/H garage door openers and outdoor receptacle circuits installed between October 1, 2015* and July 31, 2016, inclusive.*

* Installation dates are based on the applicable permit in date – either that of a standalone electrical permit or that of a related building permit.