

SECTION D-D
1-0650M-S0005 SCALE: 1:30

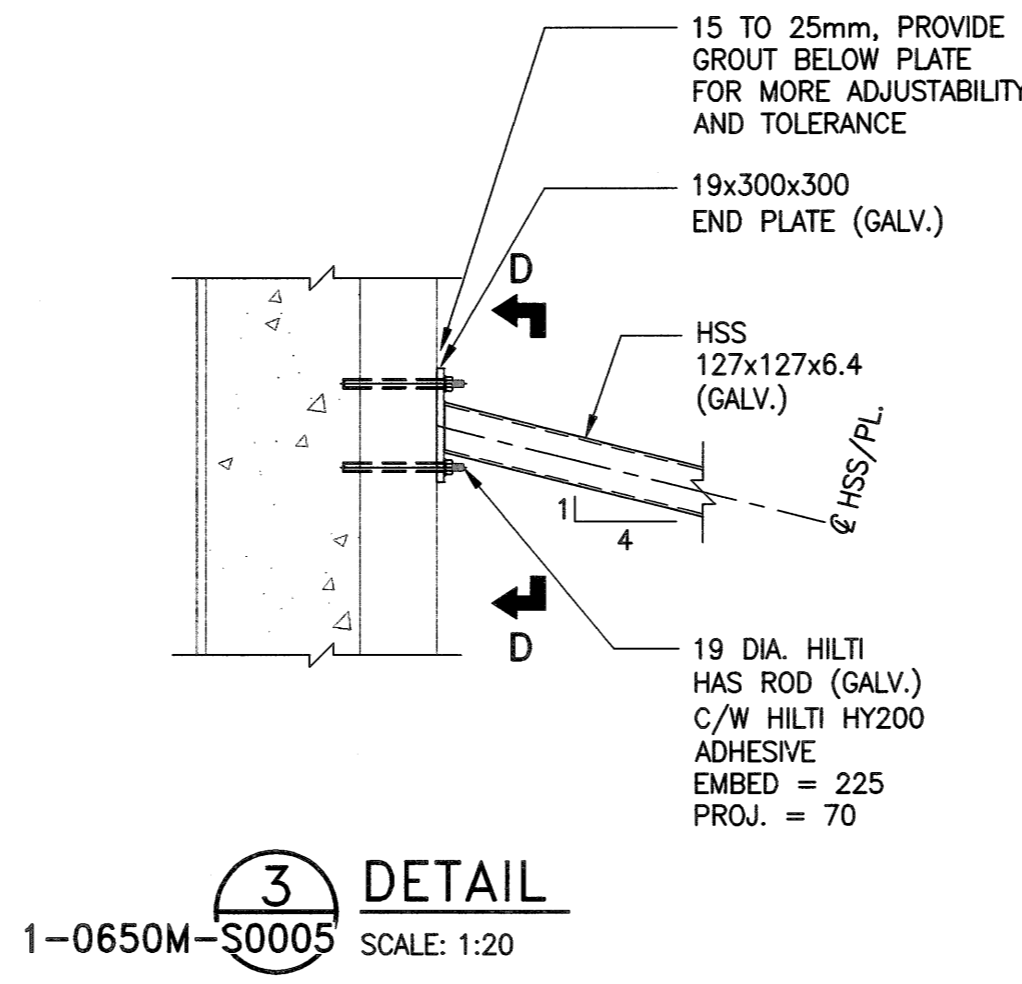

DETAIL 3
1-0650M-S0005 SCALE: 1:20

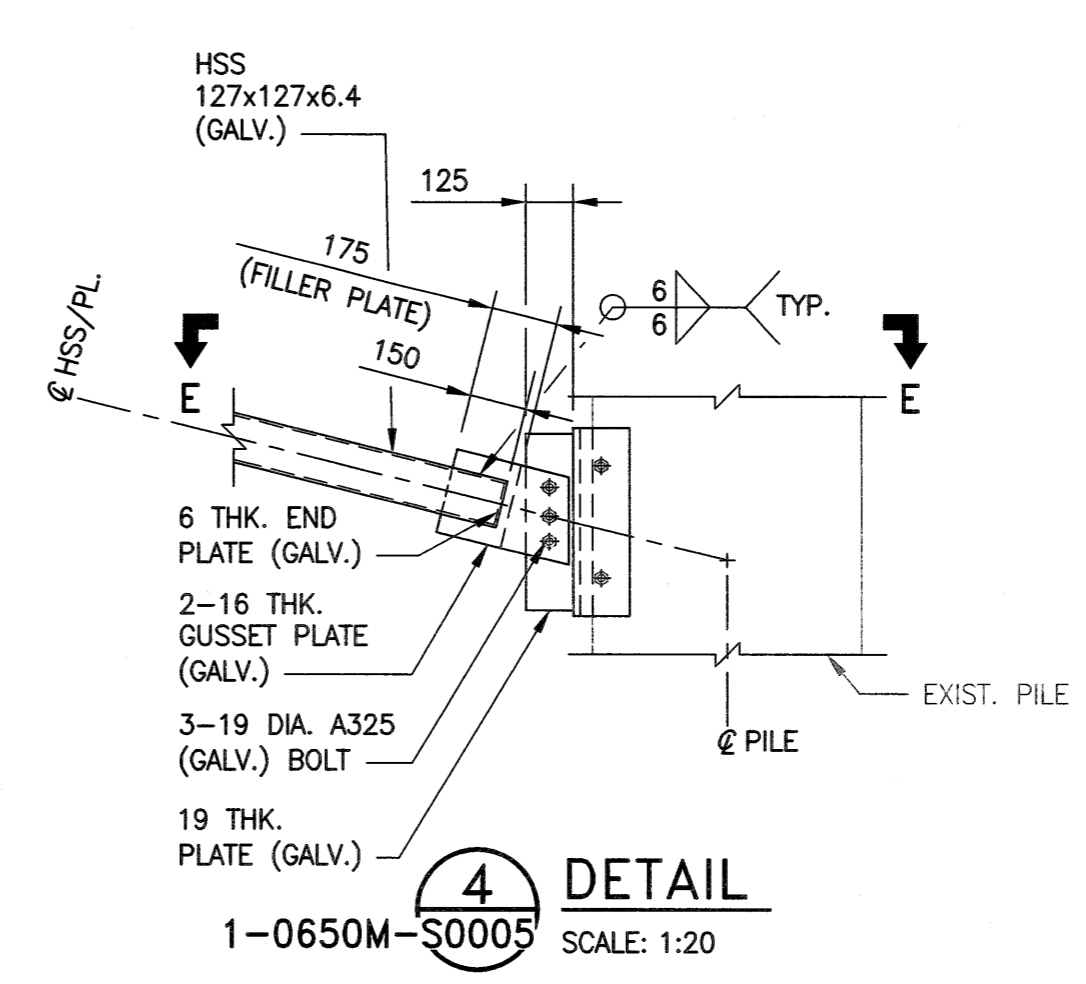

DETAIL 4
1-0650M-S0005 SCALE: 1:20

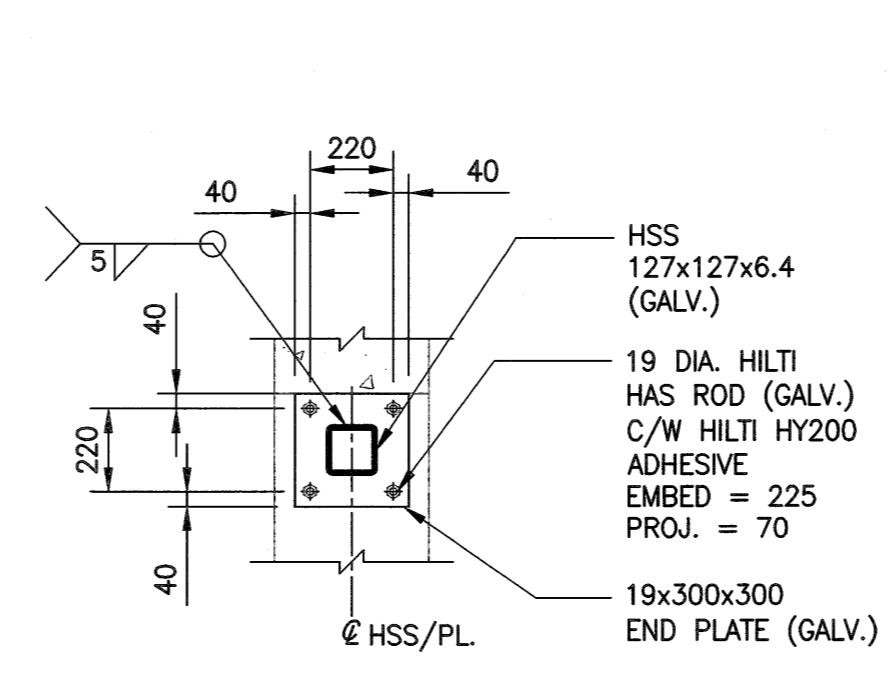

SECTION D-D
SCALE: 1:20

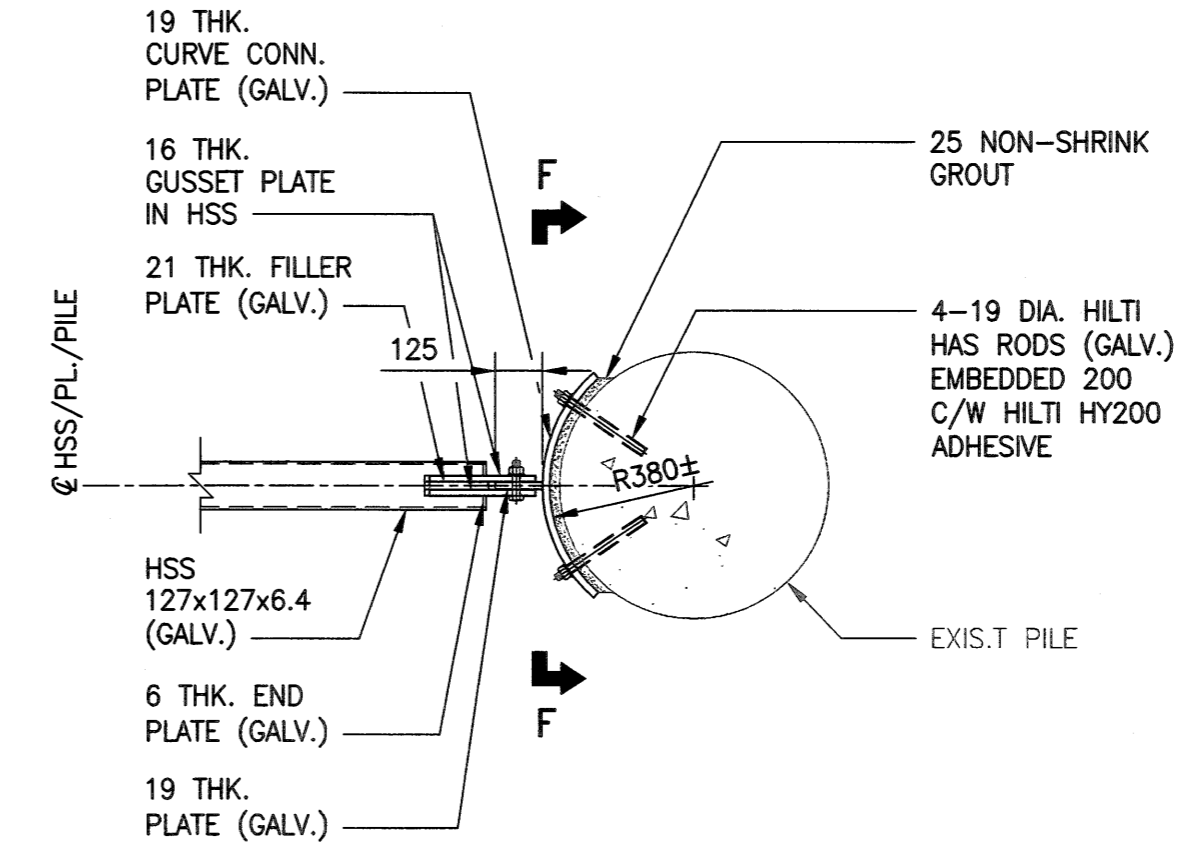

SECTION E-E
SCALE: 1:20

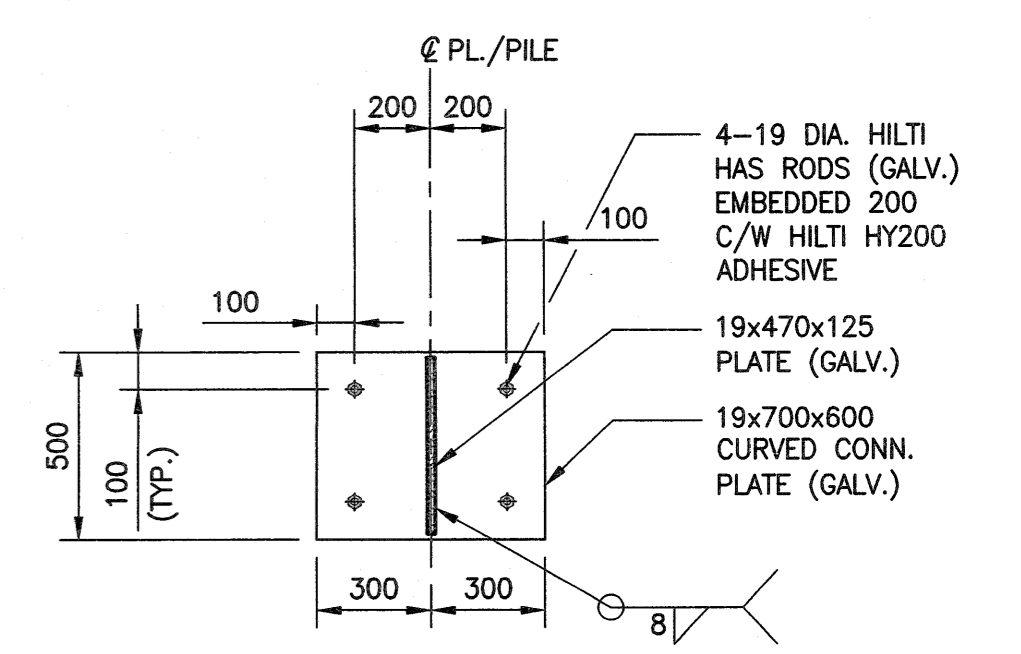

SECTION F-F
SCALE: 1:20

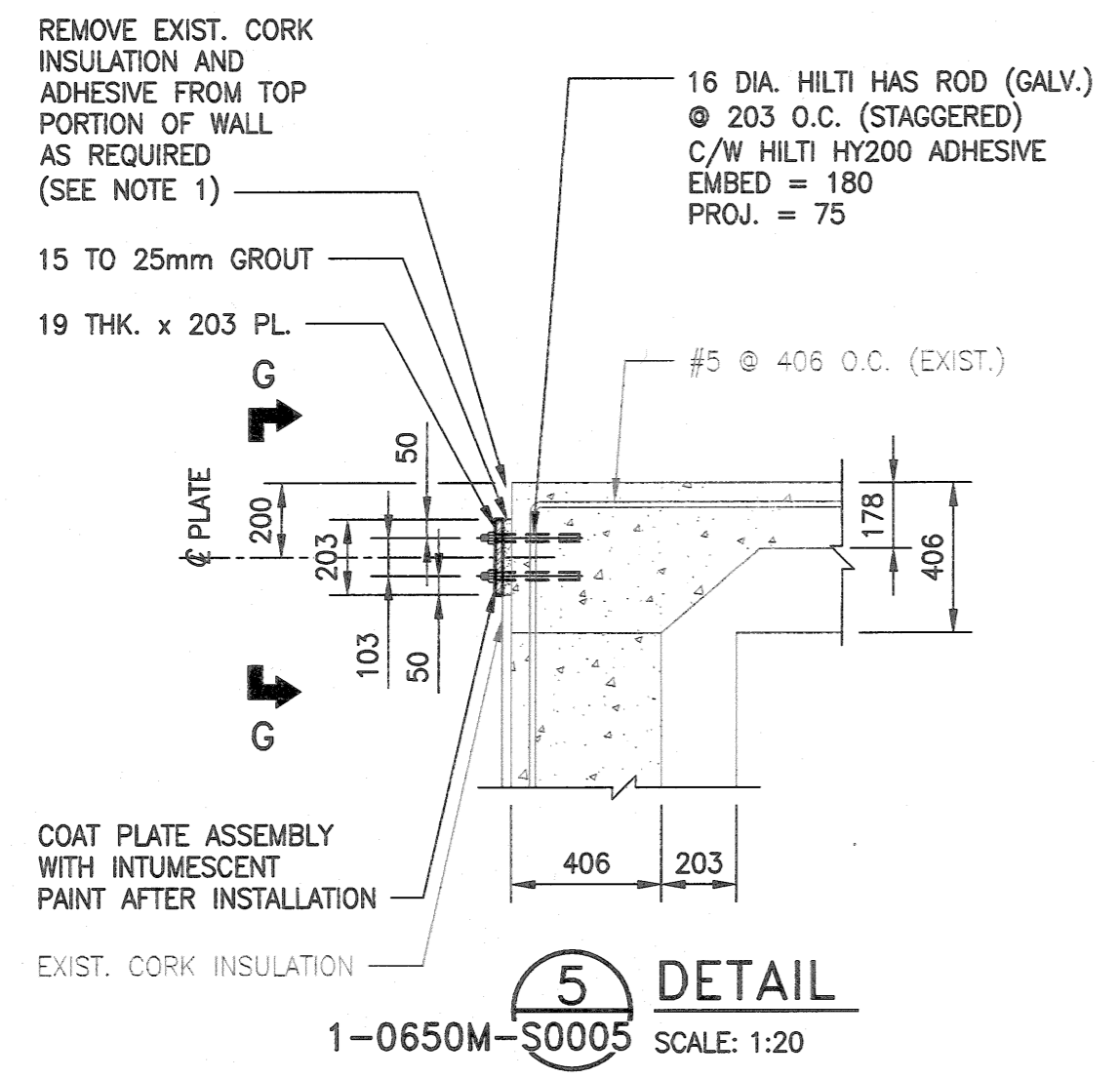

DETAIL 5
1-0650M-S0005 SCALE: 1:20

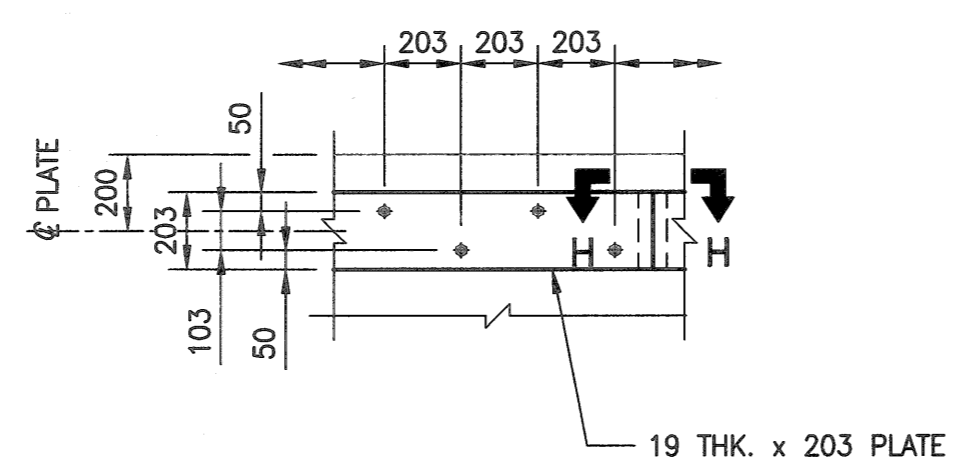

SECTION G-G
SCALE: 1:20

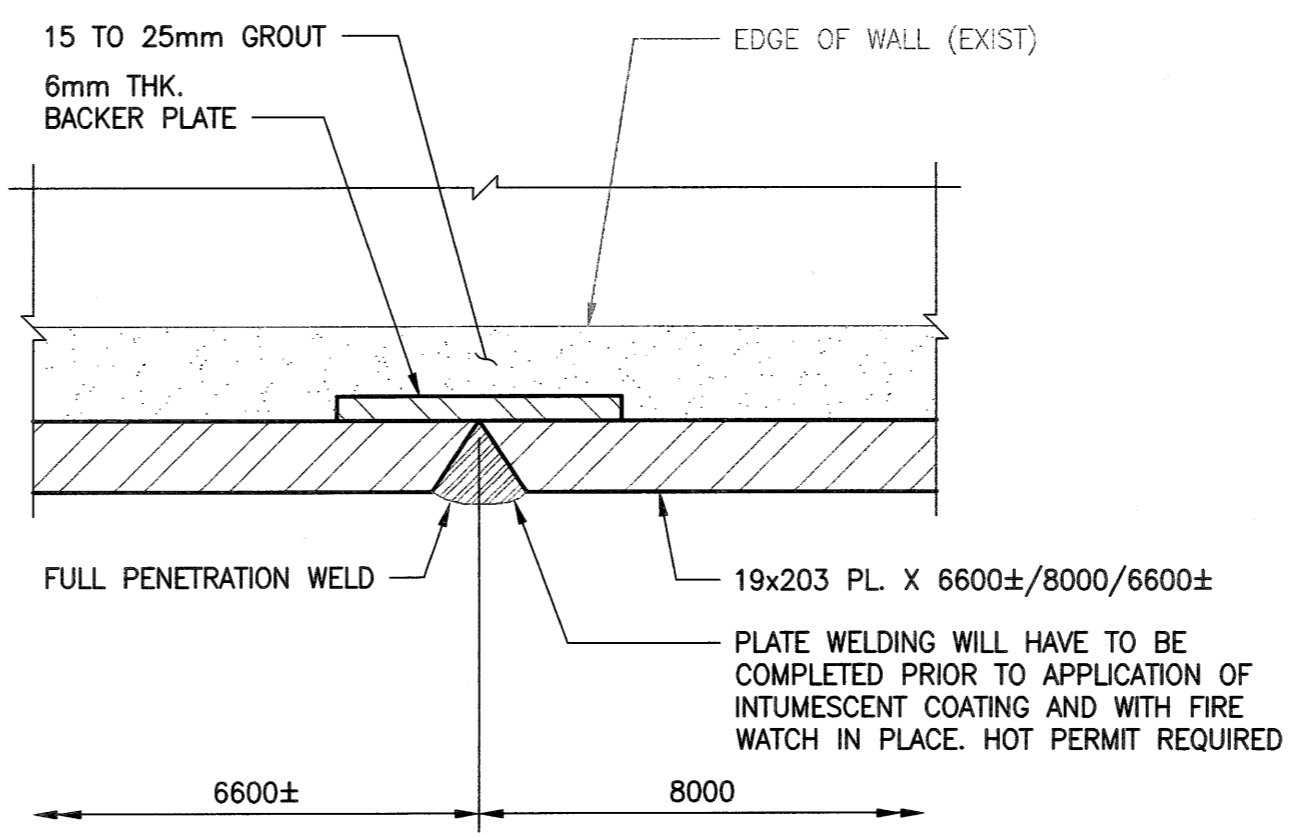

SECTION H-H
SCALE: 1:2

NOTES:
1. ADHESIVE IS FLAMMABLE. SOLVENTS MAY BE USED AND SURFACE GRINDING REQUIRED TO REMOVE ADHESIVE FROM WALL.

10		
9		
8		
7		
6		
5		
4		
3		
2	1-0650A-D0001-001	COVER SHEET
1	1-0650M-S0005-001	STRUCTURAL - CRAWLSPACE MODIFICATIONS-PARTIAL PLAN AND SECTIONS
NO.	DRAWING NUMBER	REFERENCE DRAWING TITLE
REFERENCE DRAWINGS		



B.M.	-
ELEV.	-
DESIGNED BY:	L. MILIUS-ALPHONSE
CHECKED BY:	C. SIEPMAN
DRAWN BY:	F. VALENCIA
APPROVED BY:	C. SIEPMAN
SCALE:	AS NOTED
DATE:	2019/04/30
ISSUED FOR CONSTRUCTION	2020/06/18
NO. REVISIONS	DATE
0	2020/06/18

KGS GROUP

DESIGNED BY: L. MILIUS-ALPHONSE
CHECKED BY: C. SIEPMAN
DRAWN BY: F. VALENCIA
APPROVED BY: C. SIEPMAN
SCALE: AS NOTED
DATE: 2019/04/30
ISSUED FOR CONSTRUCTION BY: C. SIEPMAN
DATE: 2020/06/18

CONSULTANT NO.: 19-0107-005_S06

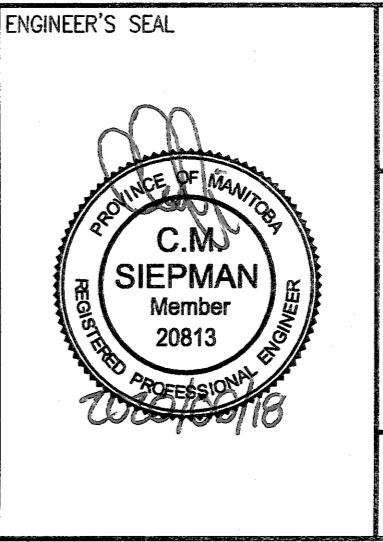

METRIC
WHOLE NUMBERS INDICATE MILLIMETRES
DECIMALIZED NUMBERS INDICATE METRES

THE CITY OF WINNIPEG
WATER AND WASTE DEPARTMENT

HURST PUMPING STATION
STRUCTURAL REPAIRS AND DRAINAGE BUILDING UPGRADES
STRUCTURAL
PUMP STATION CRAWLSPACE MODIFICATIONS
SECTIONS AND DETAILS

CITY DRAWING NUMBER: 1-0650M-S0006
SHEET: 001
REV: 0
SIZE: A1