

**ALLEY PAVEMENT PROFILE**  
SCALE: 1:250 HOR  
1:10 VER

- NOTES:**
1. ALL WORK AND MATERIALS TO BE IN ACCORDANCE WITH THE LATEST REVISION OF THE CITY OF WINNIPEG STANDARD CONSTRUCTION SPECIFICATION.
  2. CONTRACTOR TO CONFIRM THE LOCATION OF ALL UTILITIES/SERVICES IN THE FIELD PRIOR TO CONSTRUCTION.
  3. CONTRACTOR TO AVOID DAMAGE TO EXISTING TREES WITHIN THE LIMITS OF THE ALLEY RIGHT OF WAY AS OUTLINED IN THE BID OPPORTUNITY.
  4. HYDRO POLES AND ANCHORS REQUIRING TEMPORARY SUPPORT TO BE DONE AT THE EXPENSE OF THE CONTRACTOR AS REQUIRED.
  5. WHERE UNSTABLE SUB-GRADES ARE ENCOUNTERED, ADDITIONAL EXCAVATION/SUB-BASE TO BE DETERMINED BY THE CONTRACT ADMINISTRATOR AND CONSTRUCTED IN ACCORDANCE W/ CW-3110.
  6. PROPOSED ELEVATIONS GIVEN ARE FOR EDGE OF PAVEMENT.
  7. ISOLATE EXISTING HYDRO POLES AS PER SD-228C.
  8. RENEW CURB AND SIDEWALK AS DIRECTED BY THE CONTRACT ADMINISTRATOR.
  9. MODIFIED BARRIER CURB TO BE CONSTRUCTED AT ALL BACK LANE RADI.
  10. ALL EXISTING PRIVATE APPROACHES TO BE RENEWED AS DIRECTED BY THE CONTRACT ADMINISTRATOR.
  11. ADJUSTMENTS TO PROPOSED CROSSFALL, WHERE REQUIRED, ARE TO BE DETERMINED BY THE CONTRACT ADMINISTRATOR TO SUIT EXISTING DRIVEWAYS, APPROACHES, ETC.
  12. ALL BOULEVARD RESTORATION TO BE SODDED UNLESS OTHERWISE NOTED.
  13. INSTALLATION OF LIP CURBS AND THEIR LIMITS THROUGH PRIVATE APPROACHES TO BE DETERMINED BY THE CONTRACT ADMINISTRATOR.
  14. REMOVE, ADJUST, AND SUPPLY PRECAST SIDEWALK BLOCKS AS DIRECTED BY THE CONTRACT ADMINISTRATOR.

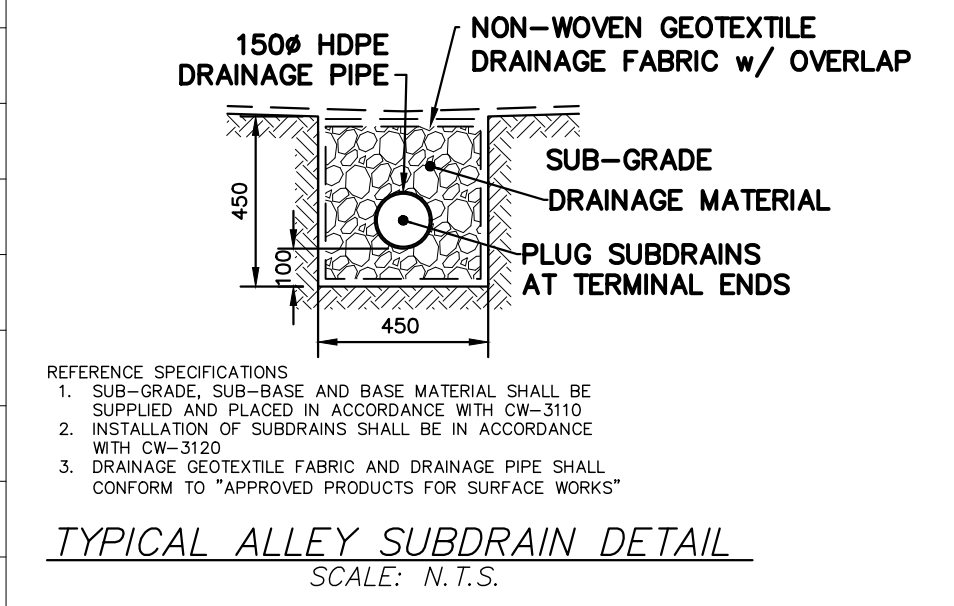
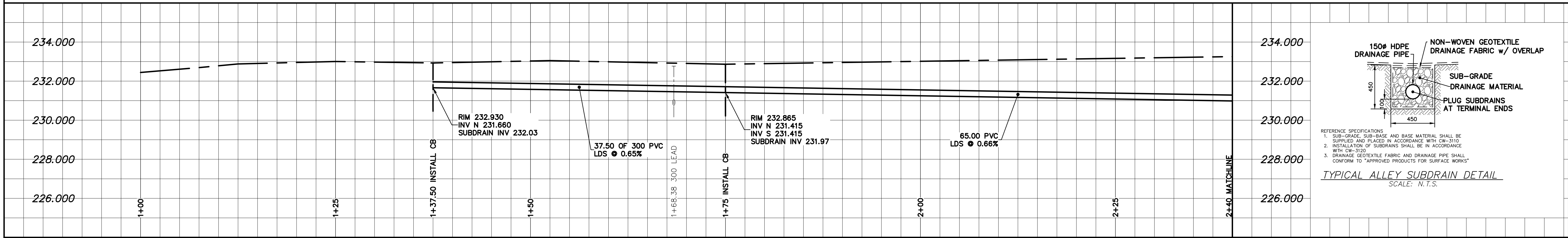

**LAND DRAINAGE SEWER PROFILE**  
SCALE: 1:250 HOR  
1:100 VER

NOTE: CHAINAGES SHOWN ARE ALONG  $\phi$  OF RIGHT-OF-WAY

THERE SHALL BE NO INCREASE IN CUMULATIVE PEAK FLOW ENTERING CS AND/OR SRS SYSTEMS AS A RESULT OF CONSTRUCTION WORKS SHOWN.

**ENGINEERS GEOSCIENTISTS MANITOBA**  
Certificate of Authorization  
**WSP Canada Group Limited**  
No. 6657

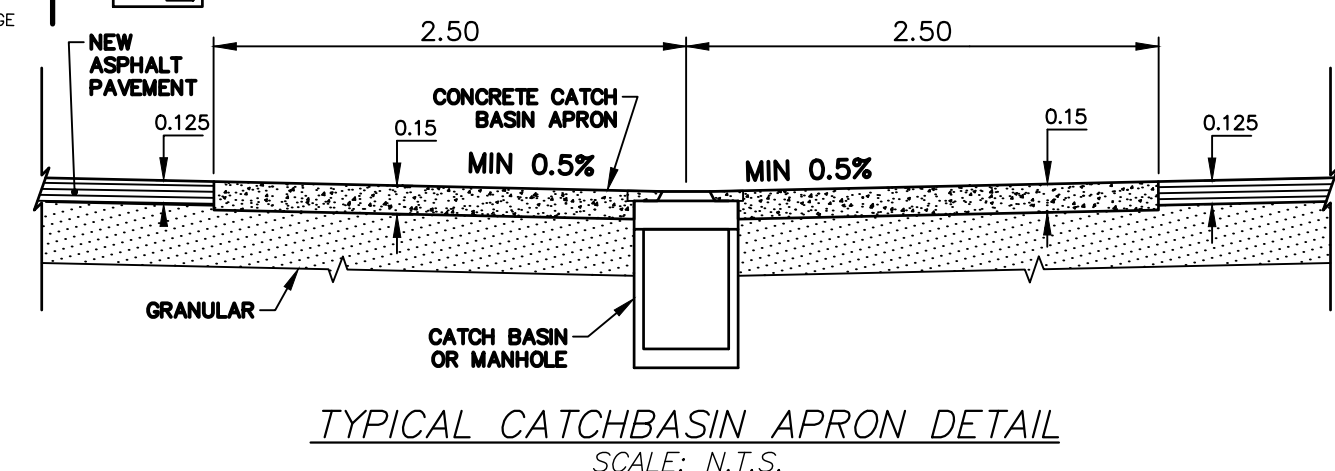
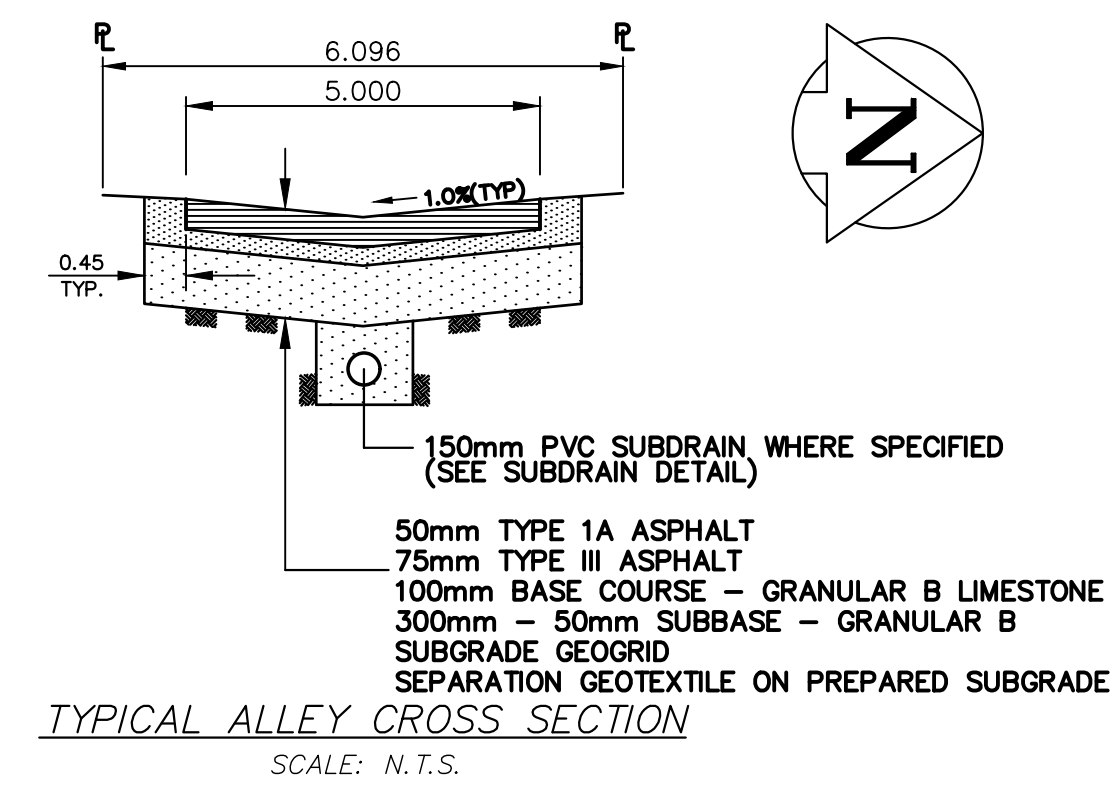
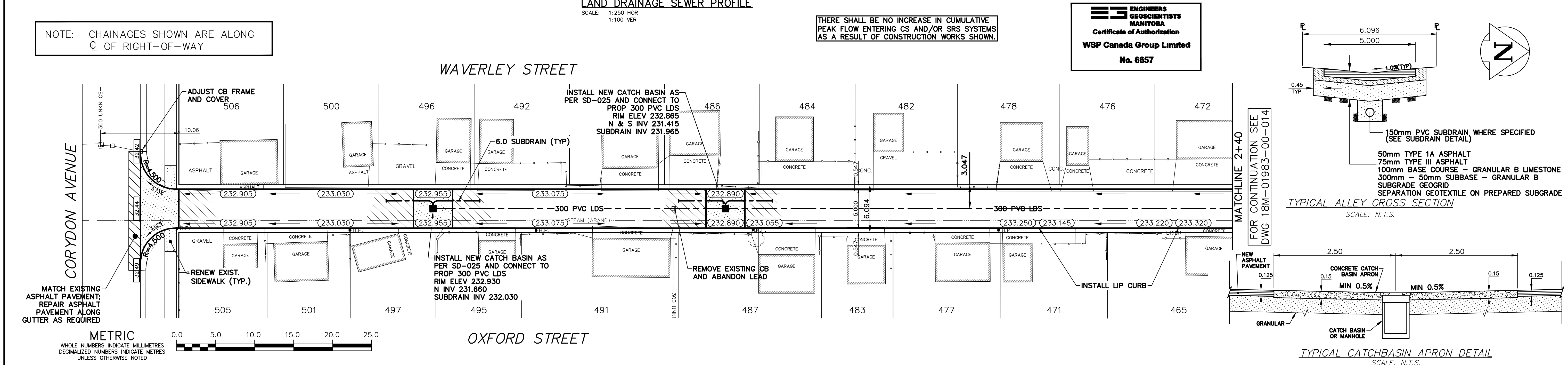

EXISTING	LEGEND - PLAN	PROPOSED	EXISTING	LEGEND - PLAN	PROPOSED	EXISTING	LEGEND - PROFILE	PROPOSED
---	WATERMAIN	---	---	M.T.S.	---	---	---	---
---	HYDRANT	---	---	CONCRETE/ASPHALT	---	---	---	---
---	VALVE	---	---	SIDEWALK	---	---	---	---
---	CURB STOP	---	---	CURB RAMP	---	---	---	---
---	LAND DRAINAGE SEWER	---	---	ELEVATIONS	---	---	---	---
---	WASTE WATER SEWER	---	---	PROPERTY LINE	---	---	---	---
---	CB LEAD	---	---	SURVEY BAR	---	---	---	---
---	MANHOLE	---	---	HYDRO POLE	---	---	---	---
---	CATCH BASIN	---	---	STREET LIGHT	---	---	---	---
---	GAS	---	---	JOINTS	---	---	---	---
---	HYDRO	---	---	ASPHALT REPAIR	---	---	---	---

**LOCATION APPROVED UNDERGROUND STRUCTURES**

SUPV. U/G STRUCTURES	DATE
---	---

NOTE:  
LOCATION OF UNDERGROUND STRUCTURES AS SHOWN ARE BASED ON THE BEST INFORMATION AVAILABLE BUT NO GUARANTEE IS GIVEN THAT ALL EXISTING UTILITIES ARE SHOWN OR THAT THE GIVEN LOCATIONS ARE EXACT. CONFIRMATION OF EXISTENCE AND EXACT LOCATION OF ALL SERVICES MUST BE OBTAINED FROM THE INDIVIDUAL UTILITIES BEFORE PROCEEDING WITH CONSTRUCTION.

**B.M. - TOP NUT OF HYDRANT AT THE NORTH EAST CORNER OF WAVERLEY ST./CORYDON AVE. INTERSECTION ELEV. - 233.489**

NO.	REVISIONS	DATE	BY
3	ISSUED FOR TENDER	21/01/20	DR
2	ISSUED FOR PW & UGS REVIEW	16/04/19	AB
1	PRELIMINARY DESIGN REVIEW	14/03/19	DR

**wsp**

111-93 Lombard Avenue  
Winnipeg, Manitoba  
R3B 3B1 Canada  
Phone: 204-943-3178  
Fax: 204-943-4948  
wsp.com

DESIGNED BY: A.B.  
CHECKED BY: A.B./R.H.  
DRAWN BY: D.R.  
APPROVED BY: S.M.

HOR. SCALE: 1:250  
VERT. SCALE: AS SHOWN

**NOT FOR CONSTRUCTION**

CONSULTANT DRAWING NO.  
18M-01983-00-13

**THE CITY OF WINNIPEG**  
PUBLIC WORKS DEPARTMENT

2019 ALLEY RENEWALS  
WAVERLEY STREET / OXFORD STREET ALLEY  
FROM CORYDON AVENUE TO STA 2+40

ASPHALT PAVEMENT

CITY DRAWING NO.  
LD-0000

SHEET 1 OF 3

BID OPPORTUNITY  
162-2020