

P:\2018\180419102-2019020 Regional St Renew Ferraor08_CAD\07_Sheets\1804191-55-Ferraor-04-06.dwg Last Saved: 2/21/2019 11:00 AM by: DDezcapol Plotted: 3/22/2019 8:58 AM by: Alex Heggenor

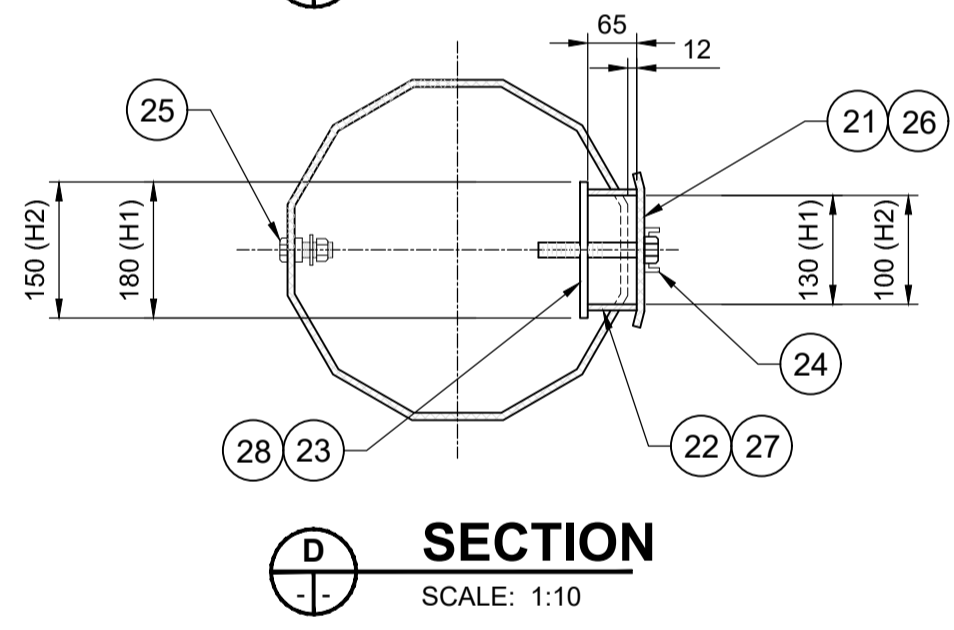

HANDHOLE - MK. H1 & H2
SCALE: 1:10

NOTE: REFER TO ORIENTATION DETAIL FOR LOCATION OF HANDHOLES. WELDED JOINTS TO COMPLETE REINFORCING RING SHALL BE 100% PENETRATION.

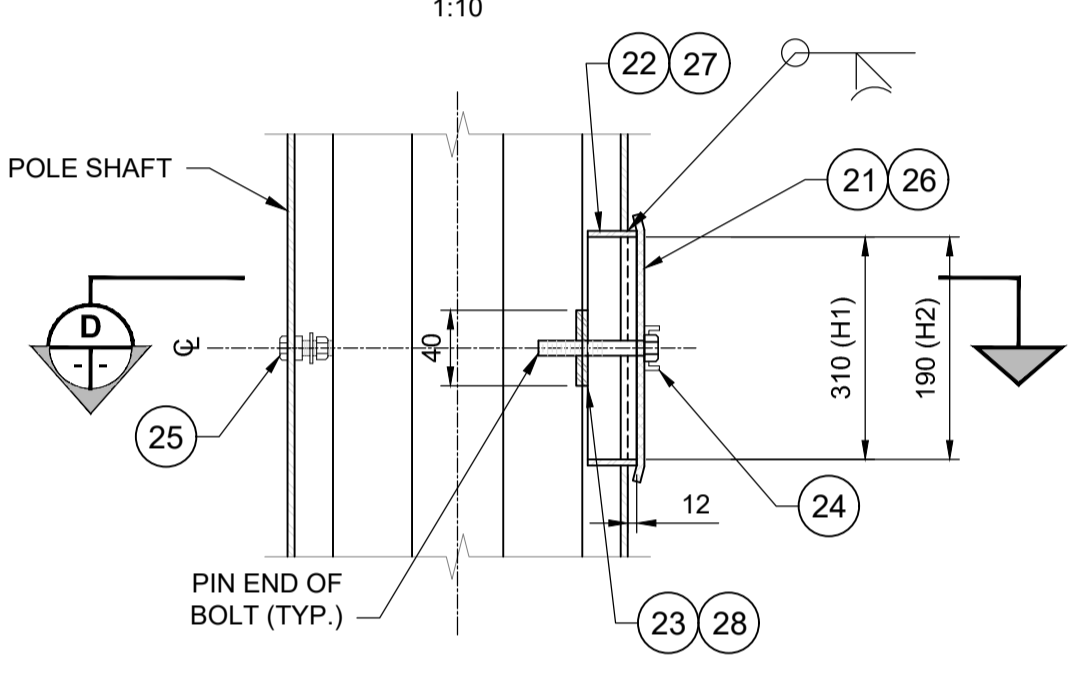
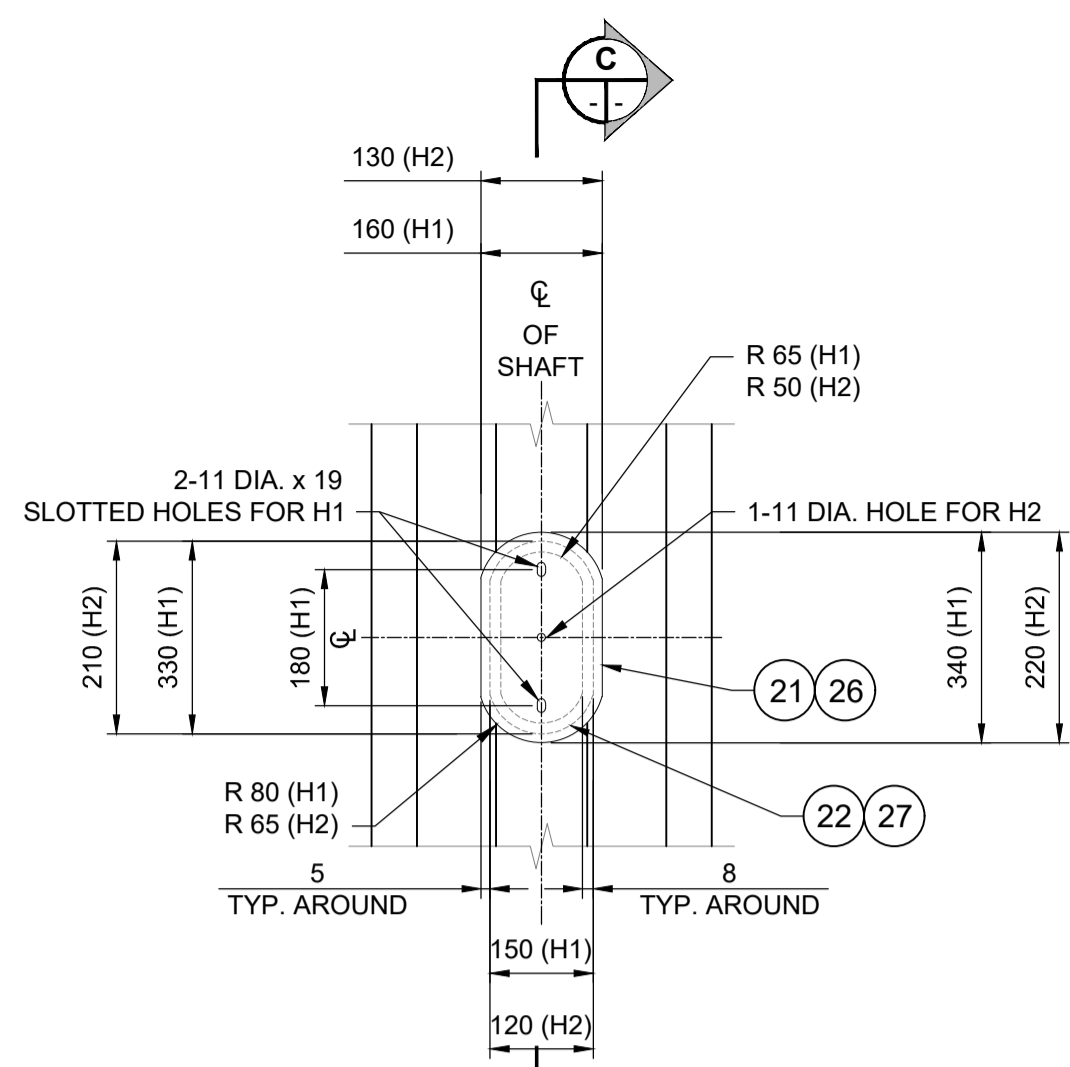
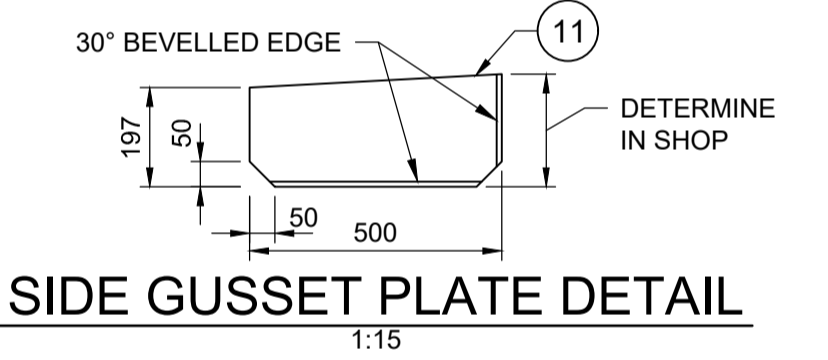
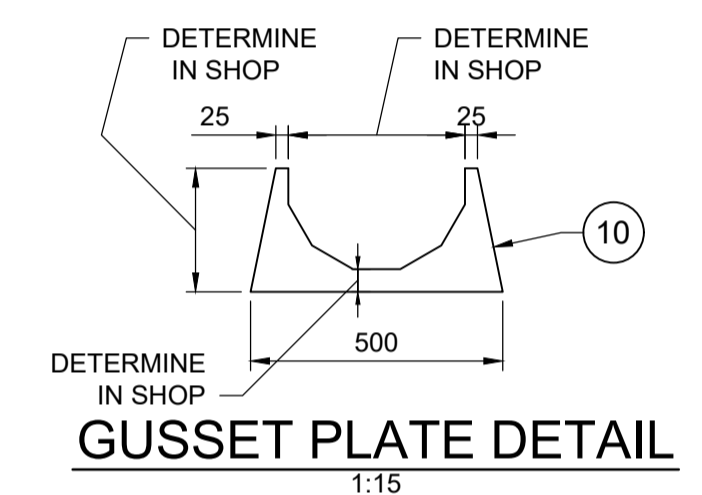
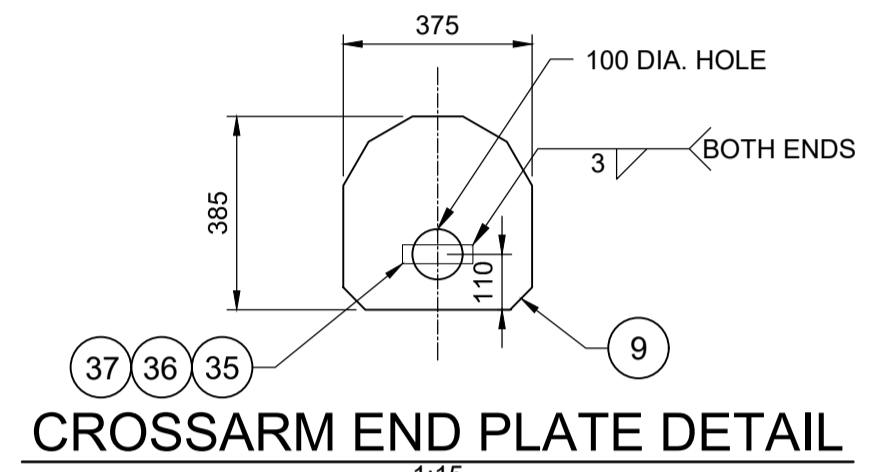
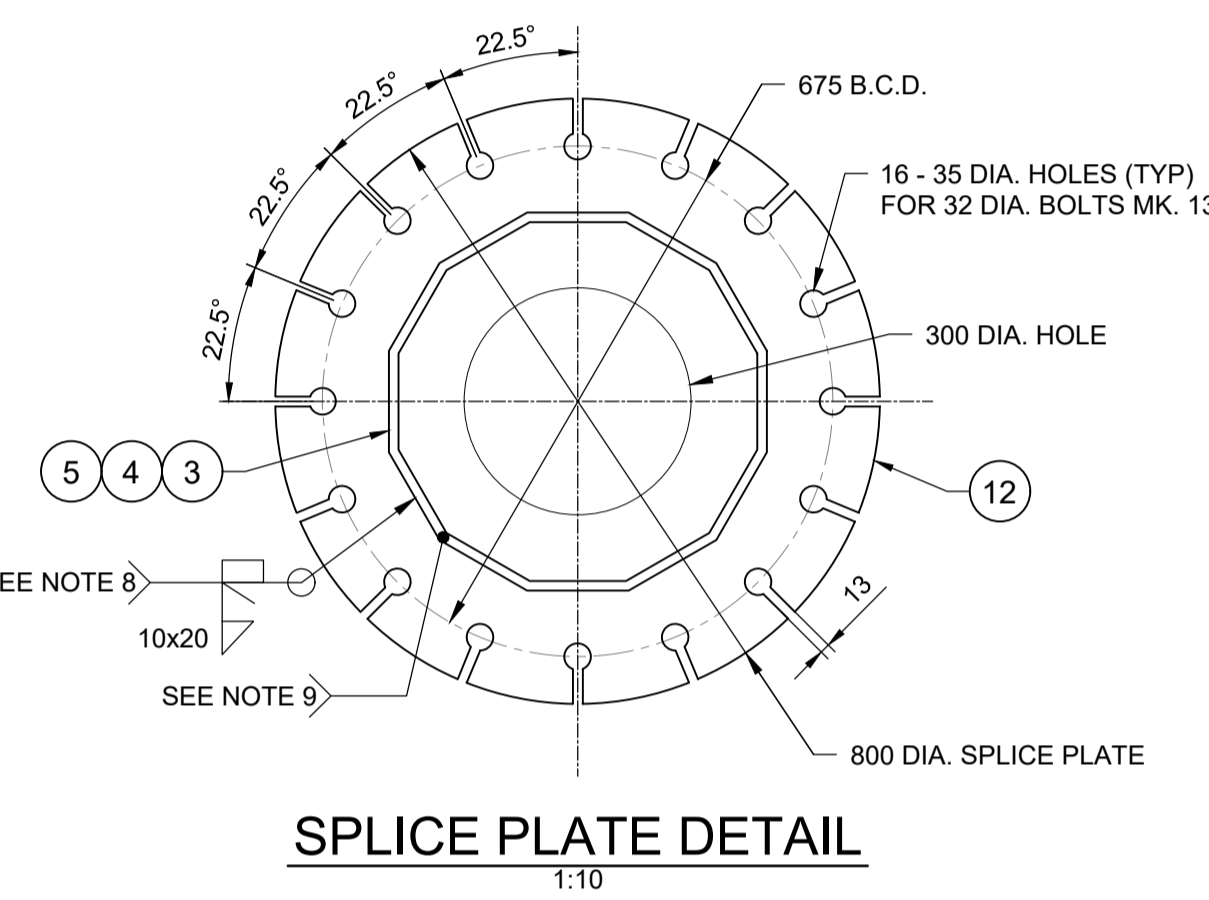
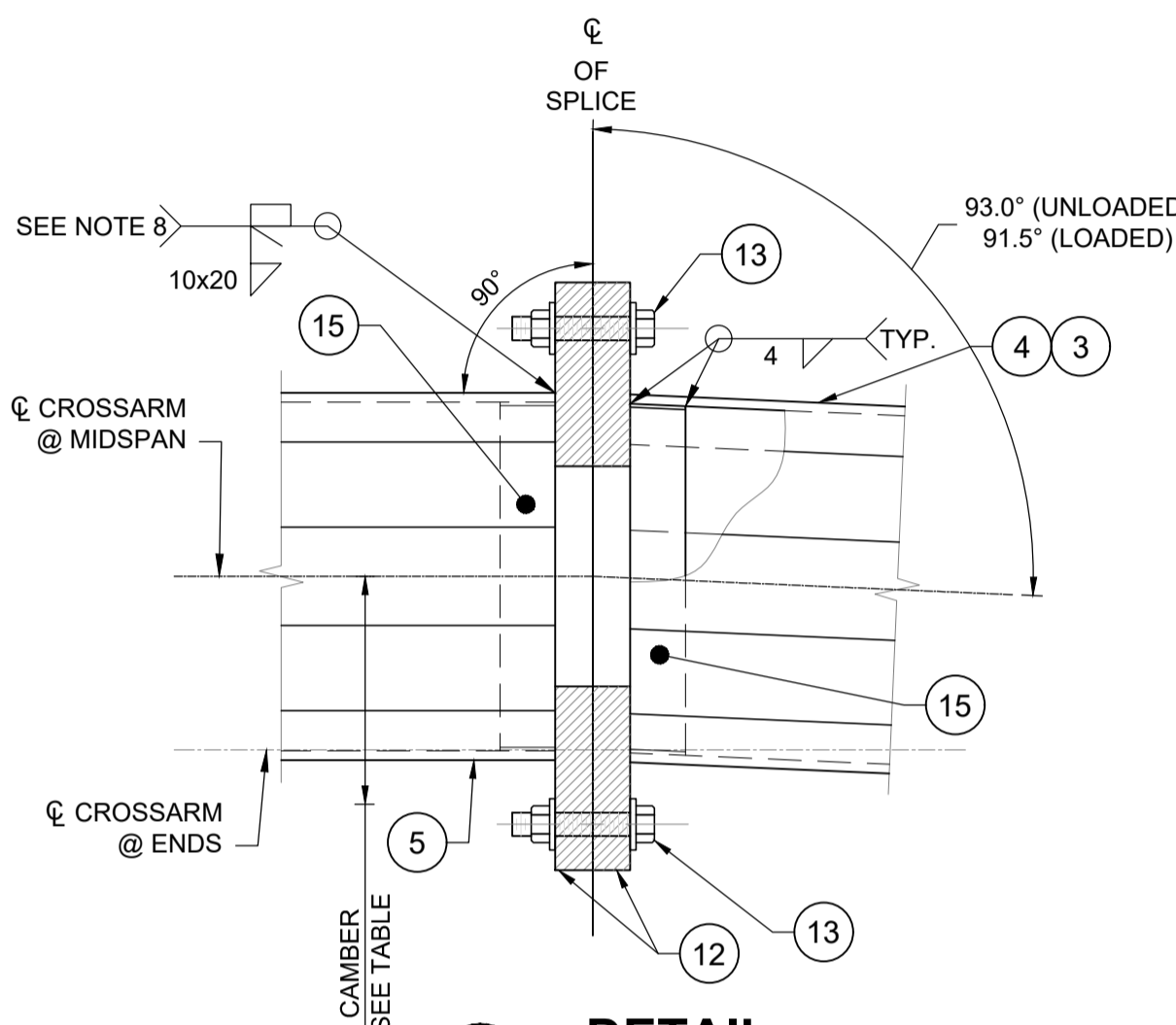
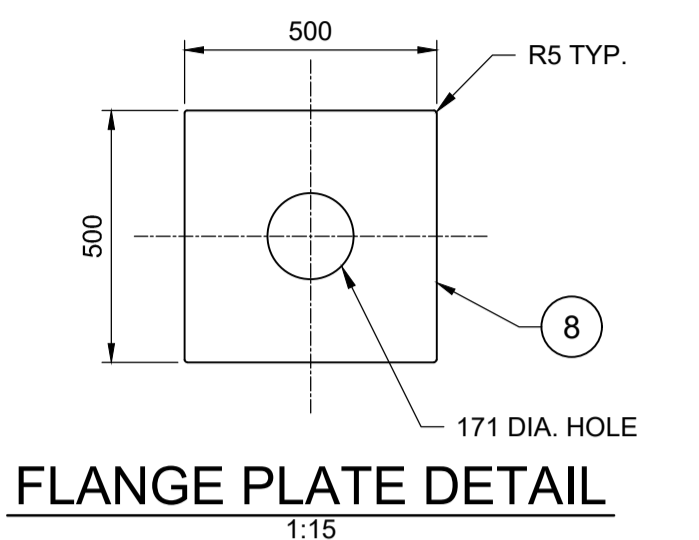
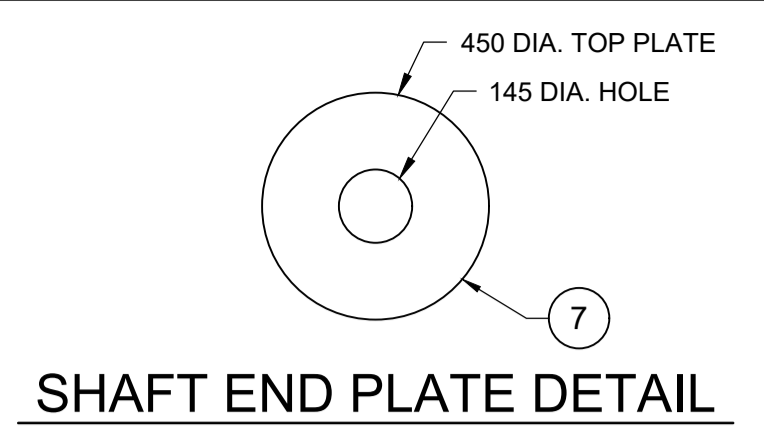
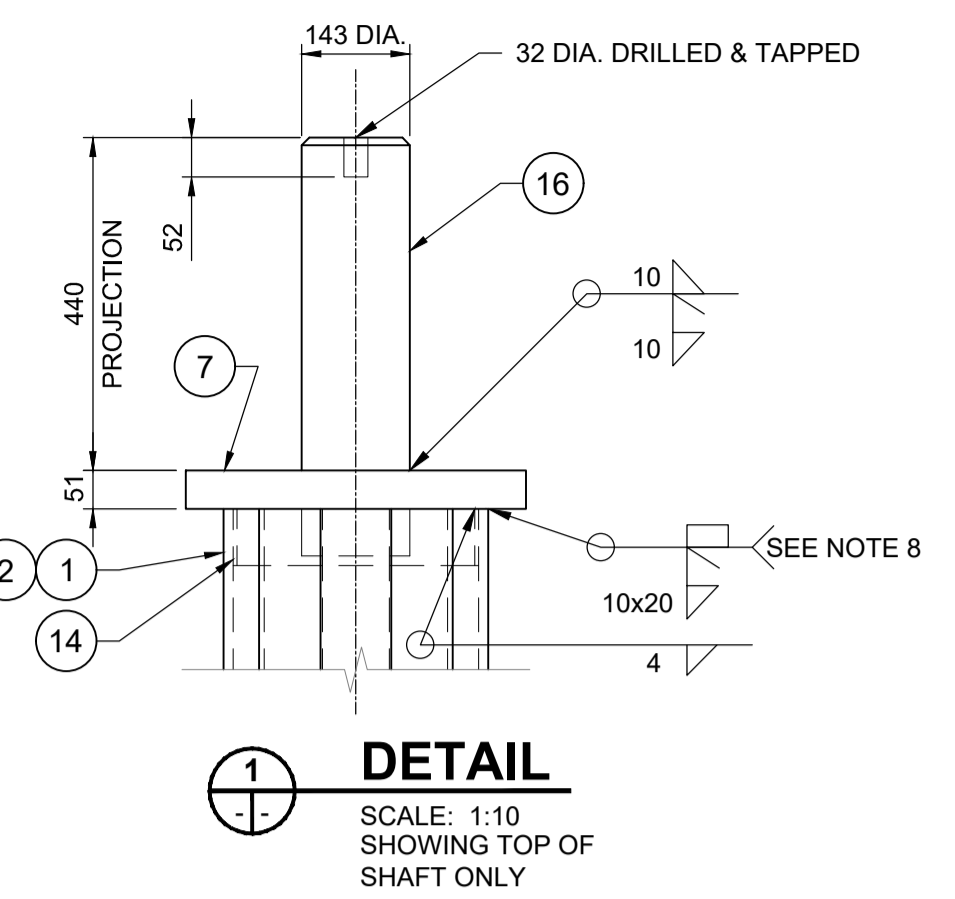
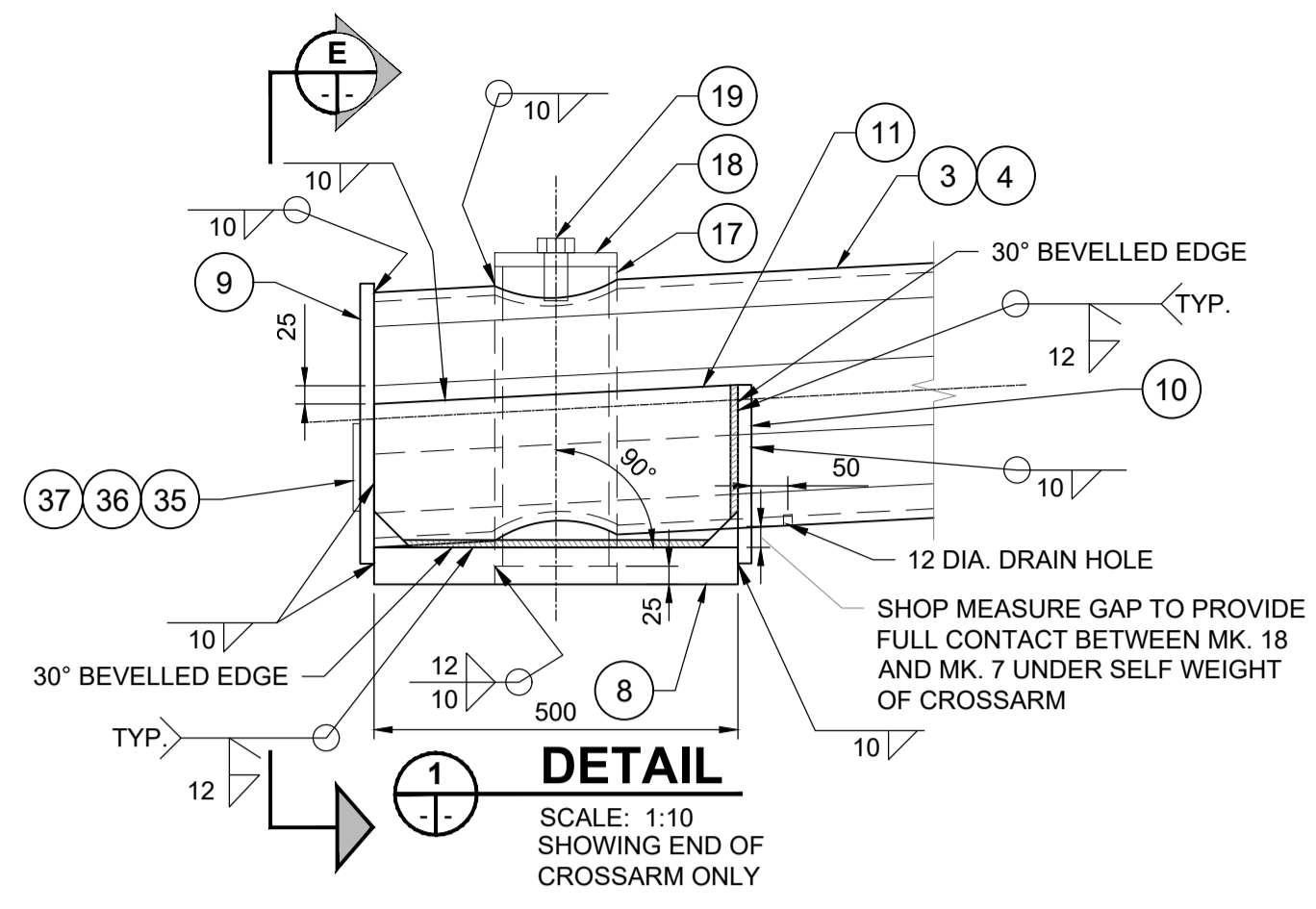

CAMBER TABLE	
CAMBER (UNLOADED)	472 mm
DEFLECTION DUE TO DEAD LOADS (CROSSARMS, ATTACHMENTS)	180 mm
CAMBER (DEAD LOAD ONLY)	292 mm
DEFLECTION DUE TO ICE LOAD	39 mm
CAMBER (DEAD LOAD + ICE LOAD)	253 mm

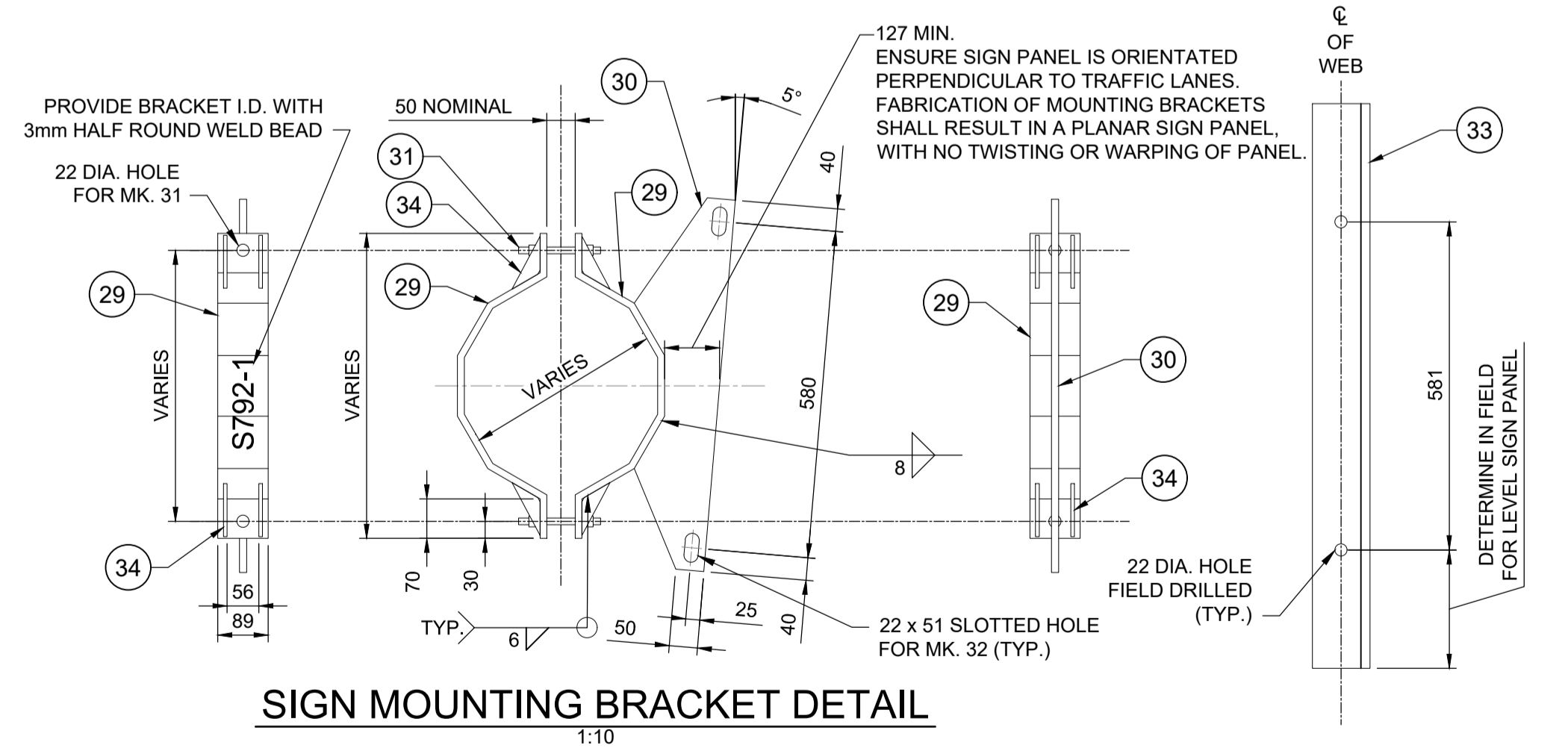
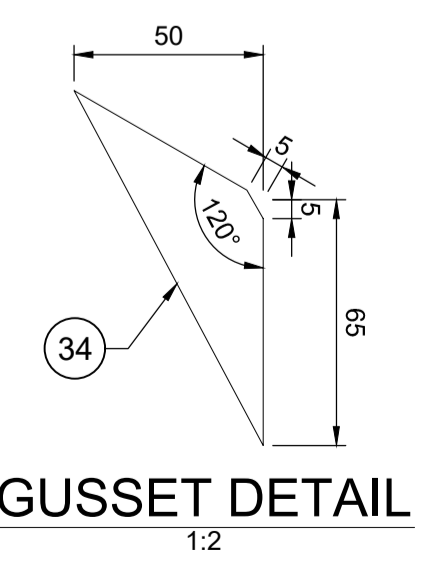
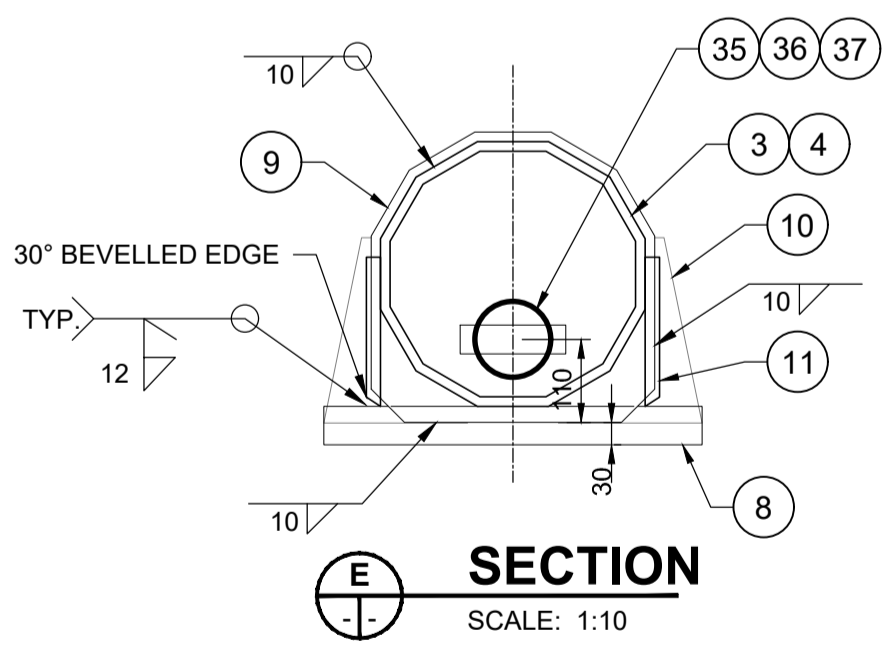

BILL OF MATERIALS		
MK.	QTY.	DESCRIPTION
1	1	DODECAGONAL SHAFT 450 A/F TO 350 A/F x 12.7
2	1	DODECAGONAL SHAFT 450 A/F TO 350 A/F x 12.7
3	1	DODECAGONAL CROSSARM 350 A/F TO 500 A/F x 12.7
4	1	DODECAGONAL CROSSARM 350 A/F TO 500 A/F x 12.7
5	1	DODECAGONAL CROSSARM 500 A/F x 12.7
6	2	BASE PLATE 750 DIA. x 51 THICK
7	2	SHAFT END PLATE 450 O.D. x 145 I.D. x 51 THICK
8	2	FLANGE PLATE 500 SQ. x 51 THICK
9	2	CROSSARM END PLATE 19 THICK
10	2	GUSSET PLATE 19 THICK
11	4	SIDE GUSSET PLATE 19 THICK
12	4	SPLICE PLATE 800 DIA. x 51 THICK (GR. 300W)
13	32	32 DIA. BOLTS C/W NUT & 2 WASHERS, GALV.
14	4	BACKUP STRIP 4.76 x 75 (FOR SHAFTS)
15	4	BACKUP STRIP 6 x 75 (FOR CROSSARMS)
16	2	SOLID ROUND PIN 143 DIA. x 600 LONG
17	2	6" SCH. 80 PIPE (168 O.D.) 415 LONG
18	2	PIN PLATE 168 O.D. 19 THICK
19	2	HEX HEAD BOLT 32 DIA. SAE GRADE 5 GALV.
20	64	PLATE WASHER 13 THICK
HANDHOLE MARK H1 (2 REQUIRED)		
21	1	COVER PLATE 11 GA. x 160 x 340 (ASTM A569)
22	1	REINFORCING RING 8 x 65 x 830
23	2	CLAMP BAR 6 x 40 x 180
24	2	10 DIA. x 140 BOLT S/S (TYPE 316)
25	1	GROUND STUD ASSEMBLY 10 DIA. x 40
HANDHOLE MARK H2 (2 REQUIRED)		
26	1	COVER PLATE 11 GA. x 130 x 220 (ASTM A569)
27	1	REINFORCING RING 8 x 65 x 555
28	1	CLAMP BAR 6 x 40 x 150
24	1	10 DIA. x 140 BOLT S/S (TYPE 316)
25	1	GROUND STUD ASSEMBLY 10 DIA. x 40
SIGN MOUNTING BRACKET (15 REQUIRED)		
29	2	CLAMP BAR 89 x 12 (LENGTH TO SUIT)
30	1	BRACKET PLATE 12 THICK
31	2	19 DIA. ASTM F1554 GRADE 55 THREADED ROD C/W 2 A563 GRADE A NUTS & F436 WASHER AND LOCK WASHER (ALL GALVANIZED)
32	2	19 DIA. x 50 S/S BOLT (TYPE 316)
33	1	ALUMINUM T-BAR 6061-T6 ASTM B221 102 x 76 x 8 LENGTH TO SUIT SIGN PANEL HEIGHT
34	8	GUSSET PLATE 6 THICK
35	2	CAP PLATE, 120 DIA. x 3 THICK
36	2	CAP RETAINER BACKING BAR 140 x 38 x 6, C/W THREADED HOLE AT CENTER FOR MK. 31
37	2	10 DIA. S/S BOLT C/W FLAT S/S WASHER

- * NOTES ON BILL OF MATERIALS:**
- MARK NO. 13: BOLT (ASTM F3125M, GRADE A325 TYPE 1), NUT (ASTM A563, GRADE D13), & 2 WASHERS (ASTM F436 TYPE 1).
 - MARK NO. 19 C/W THREAD-LOCKER SUCH AS LOCK-TITE BLUE OR APPROVED EQUIVALENT.
 - MARK NO. 23 AND 28 C/W 8-DIA. PUNCHED 10 N.C. TAPPED AT THE CENTER OF PLATE.
 - MARK NO. 24 C/W CUP WASHER.
 - MARK NO. 25 C/W 2-10 DIA. HEX NUT, 2-TERMINAL WASHER & 1-LOCKWASHER.
 - MARK NO. 32 C/W NUT, 2 WASHERS AND 1 LOCKWASHER.

LOCATION APPROVED UNDERGROUND STRUCTURES

SUPR. U/G STRUCTURES COMMITTEE DATE

NOTE: LOCATION OF UNDERGROUND STRUCTURES AS SHOWN ARE BASED ON THE BEST INFORMATION AVAILABLE BUT NO GUARANTEE IS GIVEN THAT ALL EXISTING UTILITIES ARE SHOWN OR THAT THE GIVEN LOCATIONS ARE EXACT. CONFIRMATION OF EXISTENCE AND EXACT LOCATION OF ALL SERVICES MUST BE OBTAINED FROM THE INDIVIDUAL UTILITIES BEFORE PROCEEDING WITH CONSTRUCTION.

GBM ELEV	55-015	233.170
C	ISSUED FOR TENDER	19/03/22 BAP
B	ISSUED FOR CLIENT REVIEW	19/02/15 BAP
A	N/A	-
No.	REVISIONS	YY/MM/DD BY

MORRISON HERSHFIELD

DESIGNED BY TN CHECKED BY GQW

DRAWN BY AH APPROVED BY BAP

RELEASED FOR CONSTRUCTION

HOR SCALE AS SHOWN

VERT SCALE AS SHOWN

DATE 19/02/15

PROFESSIONAL'S SEAL

PROVINCE OF MANITOBA

REGISTERED PROFESSIONAL ENGINEER

G.Q. WEI

Member 38723

CONSULTANT FILE NAME

1804191-55-Ferraor-04-06.dwg

THE CITY OF WINNIPEG PUBLIC WORKS DEPARTMENT ENGINEERING DIVISION

2019/2020 REGIONAL STREET RENEWAL PROGRAM

FERROR AVENUE

FROM LAGIMODIERE BOULEVARD TO PLESSIS ROAD (CITY BOUNDARY)

OVERHEAD SIGN STRUCTURE

S793 FERROR AVE. WB, EAST OF LAGIMODIERE BLVD.

FABRICATION DETAILS 2

CITY DRAWING NUMBER P-3501-55

SHEET 55 OF 63

DRAWING No. **55**

ENGINEERS GEOSCIENTISTS MANITOBA

Certificate of Authorization

MORRISON HERSHFIELD

No. 1736

TENDER No.8-2019