

APPENDIX 'B'

INLAID LONGITUDINAL LANE LINE MARKING PREPERATION AND APPLICATION TECHNIQUES

Traffic Safety and Security Division

Stamark™ Tapes Pavement Surface Preparation and Application Techniques

Information Folder 5.7

July 2015

Replaces IF 5.7 dated July 2014

Introduction	2
Product Application Requirements	3
Adhesive Series of Stamark Tapes.....	3
Hot Inlay Application of Long Lines.....	4
Hot Inlay Application of Transverse Markings	7
Overlay Application of Long Lines	9
Overlay Application of Transverse Markings.....	13
Storage	16
Removal.....	16
Health and Safety	16
Caution	16
Appendix A. Pavement Surface Types	17
Appendix B. Surface Preparation Adhesives.....	18
Appendix C. Road Type Surface Preparation Adhesive Application Recommendations	19
Literature Reference.....	19

Introduction

This information folder contains pavement surface preparation requirements and application procedures for 3M™ Stamark™ Pavement Marking Tapes. It is important that users be completely knowledgeable of all application requirements and procedures prior to product application. Instructions contained in this folder must be followed for material replacement provisions to be considered valid. Material replacement provisions are described in the appropriate product bulletins.

It is the responsibility of the installer to contact the 3M sales representative or 3M technical service representative whenever there is a question regarding application procedures or conditions.

3M™ Stamark™ Tape General Product Summary

Stamark tapes are durable, reflective pavement marking tapes used to mark asphalt and concrete surfaces. Stamark tape is available in white or yellow, standard widths and roll sizes, and Adhesive A series (unlined), L series (lined) or N series (no liner and no adhesive). Custom sizes are available upon request. It is also available in legend and symbol patterns. Below is a summary of each series of Stamark tape along with recommendations for appropriate uses.*

A. 3M™ Stamark™ All Weather Tape Series 380AW and 380AW-5

Stamark all weather tape is a durable pavement marking tape that is highly retroreflective under both wet and dry conditions. Series 380AW tape utilizes specially designed optics to provide wet and dry performance. Series 380AW tape can be used as a hot inlay marking on new asphalt or as an overlay marking on most asphalt and concrete pavement surfaces in good condition. Series 380AW-5 consists of standard white pavement marking tape with a 1.5 inch wide black edge to provide contrast on light colored asphalt or portland cement concrete surfaces.

B. 3M™ Stamark™ High Performance Tape Series 390, 390-5, 380IES and 380I-5 ES

Stamark high performance tape is a durable, conformable pavement marking providing a high degree of retroreflectivity and durability. This pavement marking tape is manufactured with a patterned surface that presents a near vertical profile to the motorist to maximize retroreflectance and a pliant polymer conformance layer for long term durability. Recommended for a wide variety of uses including long line, gore areas, and intersections (low to medium shear, light truck traffic only) for inlay, grooved and overlay applications. Series 390-5 and 380I-5 ES consists of standard white pavement marking tape with a 1.5 inch wide black edge to provide contrast on light colored asphalt or portland cement concrete surfaces.

C. 3M™ Stamark™ Pavement Marking Tape Series 270 ES

Stamark pavement marking tape is manufactured with a polymer conformance layer for durability and a patterned surface for reflectivity. Recommended for a wide variety of uses including intersection and longitudinal markings.

*See Information Folder 3.2 for information on 3M™ Stamark™ Removable Pavement Marking Tapes.

Overlay Product Application Requirements

The following general requirements apply to all Stamark tape applications:

- **Temperatures**
Air and Surface Temperature: Minimum 40°F (4°C) and rising
Overnight Air Temperature: Minimum 40°F (4°C) the night before tape application is recommended. If the temperature falls below 40° F, inspect the pavement surface for visible signs of moisture (dew, frost, etc.).
- Overlay applications must be completed within the seasonal start and end dates for a particular region as indicated in the 3M Climate Guide for 3M™ Stamark™ Pavement Marking Tapes.
- If outside your seasonal start or end date, you must use 3M™ Low VOC Surface Preparation Adhesive SPA60 or 3M™ Stamark™ Surface Preparation Adhesive P-50 when air and surface temperature is 40°F and rising.

Note: Regions not covered in the Climate Guide must follow minimum temperature requirements.

- **The pavement surface must be clean and dry. No precipitation within 24 hours prior to application. Other visible signs of moisture (dew or frost) cannot be present. If heavy or prolonged rain is predicted to begin within 24 hours of installation, use of Surface Preparation Adhesive SPA-60 or P-50 is recommended.**
- Butt splices must be used; do not overlap tape ends.
- Traffic must be kept off of pavement surfaces coated with a surface preparation adhesive prior to tape application. Minimize debris (dirt and excess dust) as much as possible.

Adhesive Series of Stamark Tapes

Adhesive “A” Series: Tapes with pressure sensitive adhesive.

“A” Series tapes are shipped on a roll with a release agent top coating on the pavement marking surface. The adhesive on the back of the tape is ready for placement on the road surface once the tape is peeled from the roll.

Adhesive “L” Series: Tapes with liner and pressure sensitive adhesive.

“L” Series tapes are available in both long line pavement markings as well as all symbols and legends. “L” Series tapes are shipped with a liner on the adhesive backing of the tape to allow for ease of handling prior to placement on the road surface. The liner is removed just before placement on the pavement.

Adhesive “N” Series: Tapes with no liner and no pressure sensitive adhesive.

“N” Series tapes are manufactured with no adhesive backing on the tape. “N” Series tapes must be applied with surface preparation adhesive SPA60 by using the SPA60 cylinder, hose and spray gun. (See Appendix B for more information.)

A Traffic Safety and Security Division technical service representative can be contacted at 1-800-553-1380 in the U.S. or at 1-800-265-1840 in Canada; when prompted, select technical service and then select pavement marking products.

Product Application

Stamark tapes can be applied by a hot inlay application (embedding pavement marking tape into fresh asphalt) or by an overlay application (applying tape on existing surface). The tapes can also be recessed into a grooved surface. Refer to IF 5.18 for more information about a grooved application.

Hot Inlay Application of Long Lines

Including edge, lane and channelizing lines

Stamark tapes with pressure sensitive adhesive can be applied on fresh asphalt before the finishing roller passes over the surface. Hot inlaying is the process of embedding pavement marking tape into the road surface. This is done by rolling over the applied tape with a steel-drum finishing roller while the asphalt is still warm. (See Figure 1.)

Tape above road surface (Approximately 40-50%)

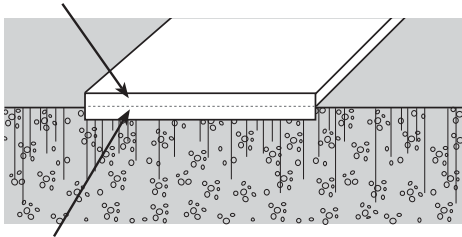

Partially Embedded Tape (Approximately 50-60%)

Cross Section of the Road

Figure 1

A. Procedure

1. Pave a lane.

Lanes should be paved so that the tape will not be placed on the asphalt seams between lanes. Generally, the width of the first lane should be approximately 12 inches (30.5 cm) short of center (for example, a 12-foot [3.7 m] wide lane should be paved at 11 feet [3.3 m] wide). The second pass will then be paved 13 feet (4.0 m) wide, for a total road width of 24 feet (7.3 m). Center line markings will then be applied on a fresh, warm mat during paving of the adjacent lane, at least four inches (10 cm) from the asphalt seam.

2. Compact the fresh asphalt with a compaction roller.

3. Premark the road.

Use 200-250 feet (60-70 m) of sash chain or thin wire cable as a guide for long line applications or snap chalk lines on the asphalt. For skip line application, mark the skip sequence on a sash chain or with chalk or paint to be followed by the pointer on a tape applicator. (See Figure 2.)

Example: A sash chain marked to the proper skip sequence with one-inch (2.5 cm) spiral key rings.

4. Test the asphalt surface.

The pavement surface must be soft enough to allow the marking to be inlaid by the steel-drum finishing roller (a ten-ton finishing roller is recommended). Generally, the desired surface temperature will be between 130°F (54°C) and 160°F (71°C). Using a surface thermometer, test the temperature of the asphalt surface. There is no minimum air temperature requirement for a hot inlay tape application; however, be advised that cooler air temperatures will result in faster cooling of the asphalt reducing the application window.

Note: If you are using a stiffer mix, rubber-based mix (rubberized asphalt), Superpave, OGFC (Open Grade Friction Course) or SMA (Stone Matrix Asphalt), you may need to increase the temperature at which the tape is recessed with a finishing roller to reach the desired amount of embedment into the surface. Hot inlay the tape with the finishing roller while the surface temperature is warm enough to get approximately 50 to 60 percent of the tape's thickness below the asphalt surface. Do not exceed 180°F (83°C).

Note: In order to achieve proper embedment, coordination is critical between the paver and the tape application contractor. It is also critical to have clear communication and definition of roles during the pre-construction meeting so everyone is working in unison.

5. Lubricate the tape applicator (if applicable).

Prepare the tape applicator for use. Spray the rear rubber wheels, front wheel, and pivot points of the tape applicator with 3M™ 5-way Penetrant, WD-40™ or equivalent light oil spray. The rear wheels and pointer wheel should be sprayed regularly to avoid asphalt build-up.

Note: Wheels may also be wrapped with duct tape. Replace regularly to avoid buildup. (See Figure 2.)

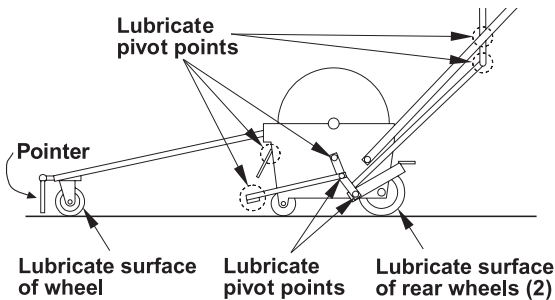

Tape Applicator

Figure 2

6. Procedure for threading tape if using the tape applicator.

Load the tape and thread over the two-inch (5.08 cm) diameter roll, adhesive side up. (Figure 3) Feed the tape in between the side frame connecting rod and the two-inch aluminum roller, then through the CLAMP to the CUTTER PLATE. Adjust the GUIDE BARS at the sides of the tape rolls to hold them securely in position.

DO NOT thread tape over the half inch diameter side frame connecting rod. This will create excessive unwind tension and stretching of the tape.

Caution:

Do not activate the cutting knife with the foot pedal while threading tape! For any other equipment questions, contact technical service at 1-800-553-1380.

Note: This list is not inclusive and other tape application equipment has been used successfully to apply 3M Stamark tapes. Please contact 3M Technical Service if there are questions about equipment not specifically listed above.

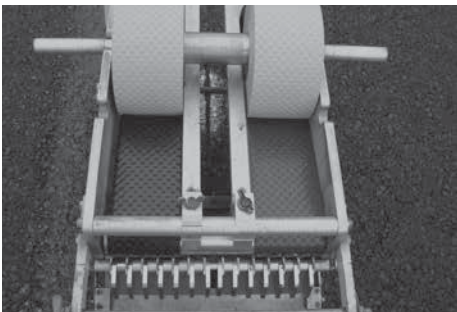

Figure 3

7. Apply the tape.

Apply the tape using the tape applicator. Make sure you do not apply the tape any closer than four inches (10.16 cm) from the asphalt seam. (See Figure 4.)

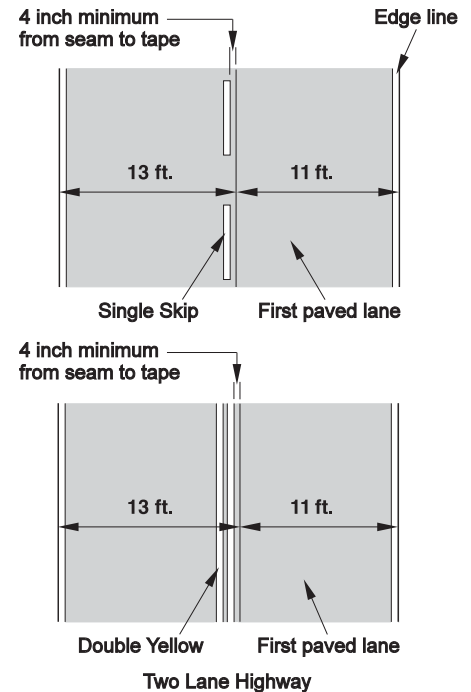

Figure 4

If pavement markings are applied using a tape applicator, the weight of the tape applicator roller will be adequate to cause the adhesive to tack with the fresh asphalt prior to rolling with the steel-drum roller. If pavement markings are placed by hand (i.e., shorter, individual skip marks), walk on the tape first to tack the adhesive on the asphalt and then roll the tape using one pass with a Roller Tamper Cart RTC-2 with 50-100 lb. (45 kg) prior to rolling with a steel-drum finishing roller.

8. Press the tape into the pavement.

Using a tandem steel-drum finishing roller (**no vibration**), slowly roll over the tape to press (inlay) it into the warm pavement surface. The tape should always be rolled (first pass) in the same direction it was applied. The speed of the finishing roller should be kept to a minimum (between two and three mph [3 and 5 kph]) when rolling over the tape during the first pass. **Use a minimum amount of water to clean and lubricate the steel drums during the hot inlay operation.**

(See Figure 5.)

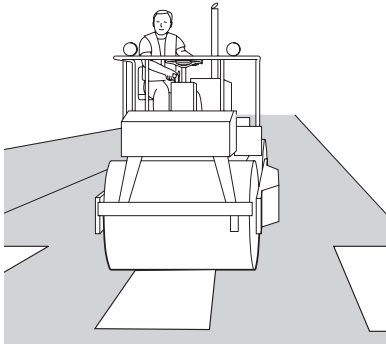

Figure 5

Note: For best inlay results the weight of the steel-drum roller should be greater than 110 PLI (Pounds per Lineal Inch) of drum width.

PLI Calculation

What you'll need:

- The width of the roller in inches as shown
- The total weight of the machine in pounds
- The number of rollers on the machine (usually two)

$$PLI = \frac{\text{Weight of machine}}{\text{Number of Rollers} \times \text{Width of roller}}$$

Example:

A machine that weighs five tons (10,000 lbs) that has two rollers that are each 60 inches wide:

$$PLI = \frac{10,000lb}{2 \times 60in} = 83.3 \frac{lb}{in}$$

Typically, a three to five ton 42 inch wide roller will apply over 140 PLI.

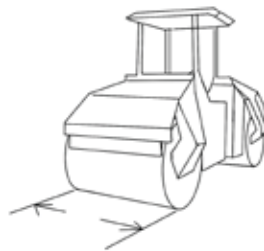

Under normal conditions, a minimum of three passes of the finishing roller is required to hot inlay the tape. **An inlay is considered successful when approximately 50 to 60 percent of the tape's thickness is below the asphalt surface.** (See Figure 1 on page 4.) To test for embedment use a 40 mil depth gauge or a bridge micrometer. For more information on embedment, contact technical service at 1-800-553-1380.

Note: If the tape wrinkles or distorts severely in front of the roller, the mat temperature may be too hot or the roller speed may be too fast. Allow the surface to cool slightly and retry. Do not remove the inlaid tape since removal of the tape will remove the asphalt.

9. Repeat Steps 1-8 until the road is fully marked.

10. Open the road to traffic.

As soon as the hot inlay operations are complete and the asphalt has cooled to temperatures that support vehicles without surface damage, the road may be opened to traffic.

Note: Tape pattern is important for visibility performance. An improper hot inlay may cause tape pattern flattening. A measured increase of applied tape width greater than 1/8 inch (3mm) may be an indication that pattern flattening has occurred.

Hot Inlay Application of Transverse Markings

Including crosswalks, stopbars, gore markings, symbols and legends

Stamark tapes with pressure sensitive adhesive (Adhesive A Series [no liner] and Adhesive L Series [with liner; also includes precut symbols and legends known as SMS-L Series]) can be applied on fresh asphalt before the finishing roller has passed over the surface. Hot inlaying is the process of embedding the pavement marking tape into the road surface. This is done by rolling over the applied tape with a finishing roller while the asphalt is still warm. (See Figure 6.)

Tape above road surface (Approximately 40-50%)

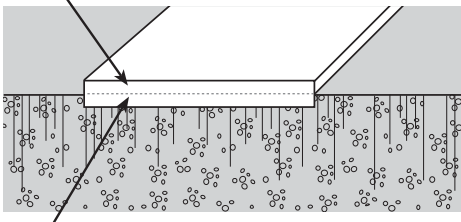

Partially Embedded Tape (Approximately 50-60%)

Cross Section of the Road

Figure 6

A. Procedure

1. **Pave a lane.** (See Step 1 on Page 4.)
2. **Compact the fresh asphalt with a compaction roller.**
3. **Premark the road.**

Using chalk, outline the area where the marking will be applied.

4. Test the asphalt surface.

The pavement surface must be soft enough to allow the marking to be hot inlaid by the steel-drum finishing roller.

Generally, the desired surface temperature will be between 130°F (54°C) and 160°F (71°C). Using a surface thermometer, test the temperature of the asphalt surface. There is no minimum air temperature requirement for a hot inlay tape application; however, be advised that cooler air temperatures will result in faster cooling of the asphalt reducing the application window.

Note: If you are using a stiffer mix, rubber-based mix (rubberized asphalt), Superpave, OGFC (Open Grade Friction Course) or SMA (Stone Matrix Asphalt), you may need to increase the temperature at which the tape is recessed with a finishing roller to reach the desired amount of embedment into the surface. Hot inlay the tape with the finishing roller while the surface temperature is warm enough to get approximately 50 to 60 percent of the tape's thickness below the asphalt surface. Do not exceed 180°F (83°C).

5. Apply the tape.

Apply the tape by hand. Cut the tape approximately 12 inches (30.5 cm) short of the asphalt seam or edge. Once the adjacent lane is paved, the tape should meet the end of the tape placed in the first paved lane. Do not overlap the material. Use butt splices. (See Figure 7.)

After the next length of tape is placed and buttspliced with the tape placed during paving of the first lane, the tape will not be inlaid through the 12-inch wide area between the seam and butt splice. To prevent tape loss in snowplow regions from this small area of tape overlay, use a utility knife to score a relief cut across the width of the tape just outside the seam and into the hot inlay area. (See Figure 7.)

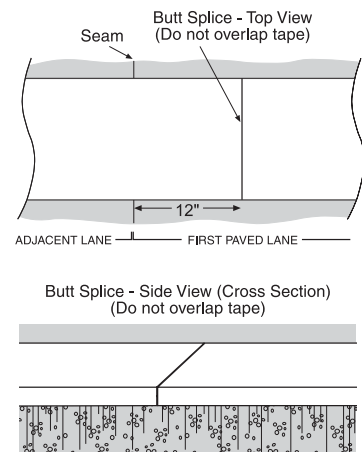

Figure 7

For material with liner (Adhesive L Series), including legends and symbols:

Position the marking and peel back the liner. Refer to IF 5.8 for liner removal techniques. Press the exposed tape down. Slowly remove the rest of the liner as the tape is carefully guided into place.

6. Tamp the tape.

Use a Roller Tamper Cart RTC-2 loaded with **100 pounds (45 kg)** (two standard 50-pound weights) to get initial tack of the tape to the asphalt. This tamping of the tape should always be done in the same direction as the marking was applied (lengthwise, not crosswise). **Start in the center of the marking**, then work toward the edges of the tape to remove trapped air. Make sure all the edges of the tape are thoroughly tamped. Do not twist or turn the tamper cart on the tape. One pass over each area is sufficient. (See Figure 8.) If the tape folds or distorts in front of tamper center, remove one 50 lb weight and continue tamping.

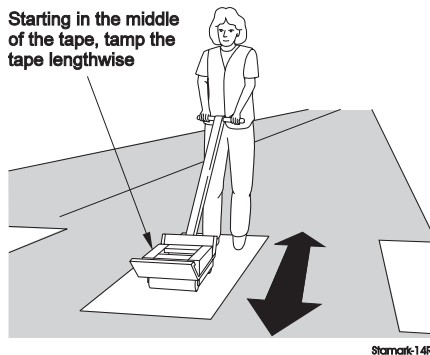

Figure 8

7. Press the tape into the pavement.

Using a tandem steel-drum finishing roller with **no vibration**, slowly roll over the tape to press (inlay) it into the warm pavement surface. Roll back and forth in a straight line over the same section of tape before moving over to the next section. The speed of the finishing roller should be kept to a minimum (between two and three mph [3 and 5 kph]) when rolling over the tape. **Use a minimum amount of water to clean and lubricate the steel drums during the inlay operation.** (See Figure 9.)

Note: For best hot inlay results the weight of the steel-drum finishing roller should be greater than 110 (Pounds per Lineal Inch) PLI of drum width.

PLI Calculation

What you'll need:

- The width of the roller in inches as shown
- The total weight of the machine in pounds
- The number of rollers on the machine (usually two)

$$PLI = \frac{\text{Weight of machine}}{\text{Number of Rollers} \times \text{Width of roller}}$$

Example:

A machine that weighs five tons (10,000 lbs) that has two rollers that are each 60 inches wide:

$$PLI = \frac{10,000\text{lb}}{2 \times 60\text{in}} = 83.3 \frac{\text{lb}}{\text{in}}$$

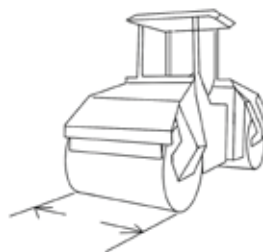
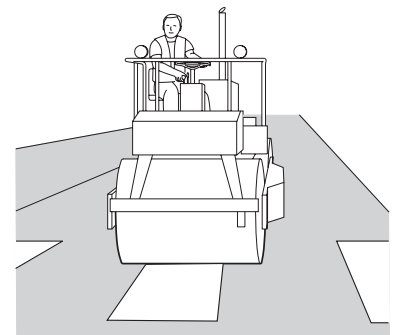

Figure 9

Typically, a three to five ton 42 inch wide roller will apply over 140 PLI.

Use a smaller roller (three to five ton) for intersection markings if one is available. Smaller rollers are generally more maneuverable and allow the markings to be hot inlaid more efficiently. It may be possible to hot inlay intersection markings in a longitudinal direction to the markings if the roller is small and the operator is experienced.



Under normal conditions, a minimum of three passes back and forth of the finishing roller are required to hot inlay the tape. **An inlay is considered successful when approximately 50 to 60 percent of the tape's thickness is below the asphalt surface.** (See Figure 1 on page 4). **To test for embedment use a 40 mil depth gauge or a bridge micrometer. For more information on embedment, contact technical service at 1-800-553-1380.**

Note: If the tape wrinkles or distorts severely in front of the roller, the mat temperature may be too hot or the roller speed may be too fast. Allow the surface to cool slightly and retry. Do not remove the inlaid tape since removal of the tape will remove the asphalt.

8. Repeat Steps 1-7 until the road is fully marked.

9. Open the road to traffic.

As soon as the hot inlay operations are complete and the asphalt has cooled to temperatures that support vehicles without surface damage, the road may be opened to traffic.

Note: Tape pattern is important for visibility performance. An improper inlay may cause tape pattern flattening. A measured increase of applied tape width greater than 1/8 inch (3mm) may be an indication that pattern flattening has occurred.

Overlay Application of Long Lines

Including edge, lane and channelizing lines

A. Procedure

This procedure explains how to apply tape to a concrete or asphalt surface in the form of edge, lane, and channelizing lines. Before you begin, make sure your environment meets all the product application requirements on page 3.

Surface preparation adhesive SPA60 and P-50 are generally the recommended surface preparation adhesive for long line pavement marking tape application, except in a few specific applications.

Use this chart to determine the proper tape and type of surface preparation adhesive to use. (See Appendix B for application coverage guidelines)

Long line application	Recommended Adhesive Series of Stamark Tape	Asphalt 0-3 days old	Asphalt 4-10 days old	Asphalt >10 days old	Concrete (b)
Edge Line	A	None	SPA60 or P-50	SPA60 or P-50	SPA60 or P-50
Center or Lane Line	A	None	SPA60 or P-50	SPA60 or P-50	SPA60 or P-50
Channelization Line	A	None	SPA60 or P-50	SPA60 or P-50	SPA60 or P-50
Edge Line at High Vehicle Crossover Location (a)	A	None	None	SPA60 or P-50 (c)	SPA60 or P-50 (c)

Notes:

- Examples could include edge lines across high volume road access points or high volume crossover traffic through a median area with edge lines.
- New concrete surfaces open to traffic less than 90 days must have the curing compound removed prior to application of surface preparation adhesive and pavement markings.
- SPA60 and P-50 are the only surface preparation adhesives recommended for use with Series 380AW, 390, 380I ES or 270 ES tapes on long line applications.

1. Determine road surface conditions.

- If surface is new concrete open to traffic less than 90 days, remove curing compound by sandblasting, shotblasting, light grinding, or hydroblasting.*
- If markings exist on the roadway, remove markings from the surface by sandblasting, grinding shotblasting or hydroblasting.*A minimum of 90 percent of the road surface under the existing markings must be exposed prior to tape application.
- Applying Stamark tape over longitudinal joints is not recommended. Premature tape failure can occur as joints can shift and degrade over time. Transverse joints or cracks that are wider or deeper than normal can prevent the tape from conforming to the road surface. As joint maintenance is required, the markings can be damaged by maintenance equipment and joint fillers. If application over any joint is necessary, cut the tape one inch (2.54cm) away from the joint on both sides.

*Note: Hydroblasting requires a 24 hour drying period before tape application

2. Clean the road.

Clean the surface of the road where the tape will be applied. Clean the surface using a high pressure, high velocity compressed air blower with minimum 185 cfm airflow and 120 psi at the air nozzle. There should be no more than 50 feet of 3/4-inch ID hose from the compressor to the air nozzle and the air nozzle should be no less than 1/2-inch ID. The compressor should also be equipped with a moisture and oil trap. It is recommended that the air nozzle be no more than two feet from the ground. A street sweeper or pickup broom may also be effective to remove larger or adhered debris, but will require a final pass with the air compressor to completely clean the surface. The road surface must be dry.

3. Premark the road. (See Step 3 on Page 4.)

4. Determine if surface preparation adhesive (SP60 or P-50) is required. For additional information on application refer to product bulletin for tape to be applied.

- If no adhesive is required, go to Step 7.
- If adhesive is required, go to Step 5.

Note: If you have any questions, contact 3M Technical Services at 1-800-553-1380. Follow the automatic prompt to reach technical service to determine if surface preparation adhesive is needed.

5. Apply the adhesive (SPA60 or P-50 only).

Using a Spray Applicator PS-14, apply a thin, uniform coat of SPA60 or P-50 adhesive to the pavement. The adhesive should extend at least one inch (2.5 cm) beyond the premarked area where the edges of the tape will be applied. (See Figure 10.) The PS-14 applicator is designed to spray a six inch (15.2 cm) wide pattern for application of four inch (10.2 cm) wide tape. The typical wet thickness is 6-7 mil.

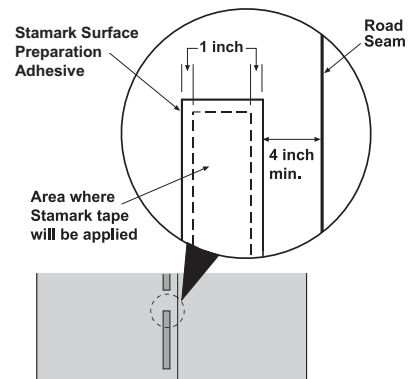

Figure 10

Adjust the arm of the PS-14 applicator up or down so that the spray pattern is six inches (15.2 cm) wide. (See Figure 11.)

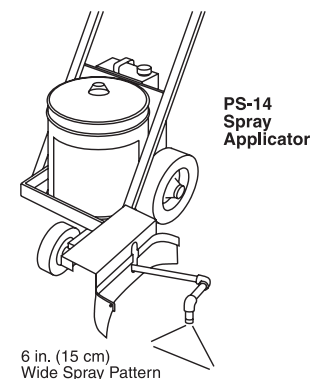

Figure 11

Note: If you are using tape wider than four inches, spray multiple passes, overlapping the previous pattern by one to two inches. Allow additional time for overlapped areas to set. See Appendix B to determine the amount of adhesive that is needed to cover a specific area.

6. Allow the adhesive to set.

- a. Allow the P-50 to set. P-50 is set when it feels tacky but is no longer in liquid form and has a matte finish rather than a glossy wet appearance. P-50 dries quickly (to a set state) under most circumstances. Typical time for P-50 to set is two to three minutes under optimal conditions of 70°F (21°C) and medium to low humidity levels. For more information on P-50 application procedures see Information Folder 5.17. See Figure 17 on page 14.
- b. Allow SPA60 to dry. SPA60 is dry when it no longer feels tacky. Dry time is approximately five minutes. Lower temperatures and higher humidity will increase dry times. For more information on SPA60 application procedures see Information Folder 5.21.

7. Procedure for threading tape if using the tape applicator.

Load the tape and thread over the two-inch (5.08 cm) diameter roll, adhesive side up. (Figure 12) Feed the tape in between the side frame connecting rod and the two inch aluminum roller, then through the CLAMP to the CUTTER PLATE. Adjust the GUIDE BARS at the sides of the tape rolls to hold them securely in position. **DO NOT** thread tape over the half inch diameter side frame connecting rod. This will create excessive unwind tension and stretching of the tape. **Caution:** Do not activate the cutting knife with the foot pedal while threading tape!

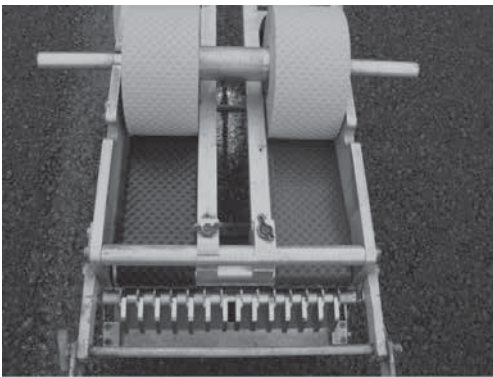

Figure 12

Note: This list is not inclusive and other tape application equipment has been used successfully to apply 3M Stamark tapes. Please contact 3M Technical Service if there are questions about equipment not specifically listed above.

8. Apply the tape.

Apply the tape using the tape applicator. Make sure the tape is not applied any closer than four inches (10.16 cm) from longitudinal seam.

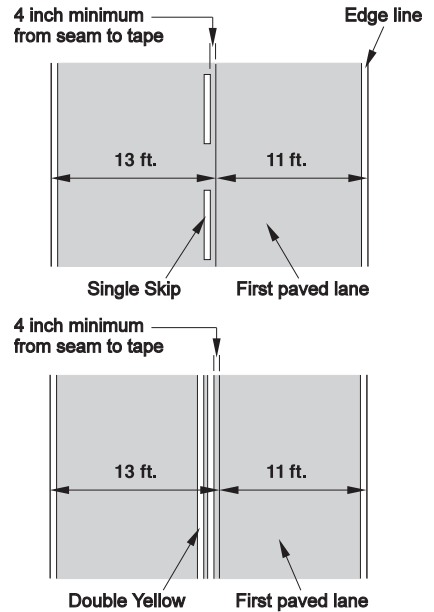

Figure 13

If pavement markings are placed by hand (i.e. shorter, individual skip marks), walk on the tape first to tack the adhesive on the pavement surface.

Note: If there is a crack in the pavement or if the tape is to be applied over a bridge expansion joint, lay the tape over the crack or joint, then cut the tape one inch away from the crack or joint on each side. (See Figure 14.)

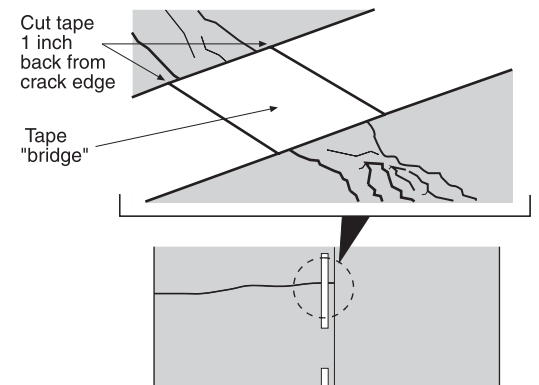

Figure 14

9. Tamp the tape. VERY IMPORTANT!

Tamp the tape thoroughly with the RTC-2 tamper cart with a minimum **200-pound (90-kg)** load making a minimum of six passes, or slowly drive over the tape for a total of six tire hits with a vehicle. The vehicle must be equipped with a pointing device to aid in keeping the vehicle on the tape, making six passes forward over the tape. Use a vehicle tire on long line markings only.

When using the RTC-2 tamper cart (See Figure 8, Page 8):

- Do not twist or turn the tamper cart on the tape.
- Make a minimum of six tamping hits all forward passing. Tire strikes from front and rear wheels when aligned with the aid of a pointer can be completed in 3 passes.
- If tape is wider than the roller or vehicle tire, more passes will be needed to make sure the entire width of the tape has received the required tamping treatment. **TAMPING IS MOST IMPORTANT STEP OF THE TAPE APPLICATION PROCESS!**
- Make sure all edges are firmly adhered.

10. Open the road to traffic.

Overlay Application of Transverse Markings

Including crosswalks, stopbars, gore markings, symbols and legends

A. Procedure

This procedure explains how to apply tape to a concrete or asphalt surface in the form of crosswalks, stopbars, gore markings, symbols and legends. Before you begin, make sure your environment meets all the product application requirements on page 3.

Use this chart to determine the proper tape and type of surface preparation adhesive to use. (See *Appendix B for application coverage guidelines*).

Notes: High shear exposures may require the use of SPA60 or P-50. Refer to appendix C for guidelines.

Transverse Marking Application	Recommended Adhesive Series of Stamark Tape	Recommended Surface Preparation Adhesive Asphalt			
		Asphalt 0-3 days old	Asphalt 4-10 days old	Asphalt >10 days old	Concrete (b) Concrete (a)
Crosswalks	A, L or N*	None	None	SPA60 (b) or P-50 (f)	SPA60 (b) or P-50 (f)
Stop Bars	A, L or N*	None	None	SPA60 (b) or P-50 (f)	SPA60 (b) or P-50 (f)
Symbols & Legends	L or N*	None	SPA60 (b) or P-50 (f)	SPA60 (b) or P-50 (f)	SPA60 (b) or P-50 (f)
Gore Markings in Minimal Traffic Area (c)	A or N*	None	SPA60 or P-50 (e)	SPA60 (b) or P-50 (f)	SPA60 (b) or P-50 (f)
Gore Markings in Heavy Traffic Area (d)	A or N*	None	SPA60 or P-50 (e)	SPA60 (b) or P-50 (f)	SPA60 (b) or P-50 (f)

***Use only SPA60 for Adhesive Series "N" tapes.**

- New concrete surfaces open to traffic less than 90 days must have the curing compound removed prior to application of surface preparation adhesive and pavement markings.
- "N" Series tape application requires four passes of SPA60 to the road surface and four passes to the back of the tape.
- Gore markings in minimal traffic areas include gores at highway on-ramps and off-ramps where minimal traffic crosses over the pavement markings.
- Gore markings in heavy traffic areas include hatched median areas along urban roadways where high levels of traffic cross over the pavement marking.
- SPA60 or P-50 may be used for gore areas with minimal to no cross-over traffic.
- SPA60 or P-50 are the only surface preparation adhesives recommended for use with Series 380AW, 390, 380I ES and 270 ES tapes for transverse marking application.

See Appendix C for guidance on the use of SPA60 and P-50 based on road type.

1. Determine road surface conditions.

- If surface is new concrete, open to traffic less than 90 days, remove curing compound by light grinding, sandblasting, shotblasting or hydroblasting.*
- If markings exist on the roadway, remove markings from the surface by grinding, sandblasting, shotblasting or hydroblasting.* A minimum of 90 percent of the road surface under the existing markings must be exposed prior to tape application.

****Note:** Hydroblasting requires a 24 hour drying period before tape application

2. Clean the road.

Clean the surface of the road where the tape will be applied. Clean the road surface using high velocity, high pressure compressed air blower with minimum 185 cfm airflow and 120 psi at the air nozzle (recommended). The road surface must be dry.

3. Premark the road.

Layout the area where the marking will be applied.

4. Determine if surface preparation adhesive is required.

(See page 3.) For additional information on application refer to the product bulletin for the tape being applied.

- If no adhesive is required, go to Step 11.
- If adhesive is required, go to Step 5.

5. Stir the adhesive.

Stir and thoroughly mix the SPA60 or P-50 adhesive with a wide wooden paint paddle or air driven paint mixer or roll unopened five gallon pail back and forth several times until adhesive is thoroughly mixed. **Make sure any sediment on the bottom of the five-gallon container is completely stirred into a consistent solution.** (See Figure 15.)

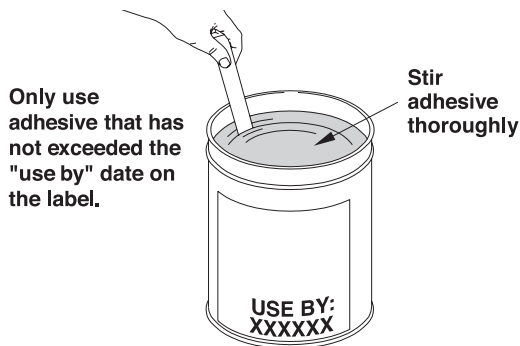

Figure 15

6. Apply the adhesive.

- If using SPA60 or P-50 adhesive on asphalt four to ten days old, see Step 5 on Page 10.
- If using SPA60 or P-50 for an intersection or and transverse marking - including legends and symbols - evenly apply one coat of adhesive to the road surface using a solvent-resistant roller with a minimum 3/8-inch nap to a maximum 3/4-inch nap. The coating on the pavement must extend at least one inch (2.5 cm) beyond the premarked area. (See Figure 16.)

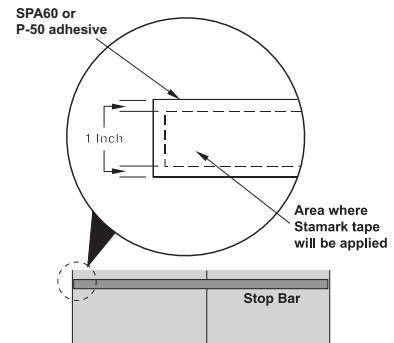

Figure 16

7. Allow the adhesive to set.

- Allow the P-50 to set. P-50 is set when it feels tacky but is no longer in liquid form and has a matte finish rather than a glossy wet appearance. P-50 dries quickly (to a set state) under most circumstances. Typical time for P-50 to set is two to three minutes under optimal conditions of 70°F (21°C) and medium to low humidity levels. For more information on P-50 application procedures see Information Folder 5.17. (See Figure 17.)



Figure 17

- Allow SPA60 to dry. SPA60 is dry when it no longer feels tacky. Dry time is approximately five minutes. Lower temperatures and higher humidity will increase dry times. For more information on SPA60 application procedures see Information Folder 5.21.

8. Remark the road (if needed).

9. Determine next step, based on tape adhesive series being used.

- a. If tape is Adhesive Series A (with adhesive), go to Step 11.
- b. If tape is Adhesive Series L (with adhesive and a liner), then go to Step 11.
- c. If tape is Adhesive Series N (no adhesive and no liner), go to Step 10.

10. Adhesive N Series (tape with no adhesive or liner) only. Spray apply four passes of SPA60 to the road surface and apply four passes to the back of the tape with the SPA60 spray cylinder.

NOTE: While spraying during the four by four pass system it is allowed to spray two light passes to the road surface and two light passes to the back of the tape. Allow three to five minutes to dry at normal conditions of 70°F (21°C). Cooler temperatures may require longer drying period. After dry period, respray two more passes on road and two more passes on back of the tape. This will allow the SPA60 adhesive to dry faster and set up evenly for correct bond. SPA60 is set once the adhesive is tack free which takes approximately five minutes depending on air temperature and humidity. Set time will change depending on climate conditions.

Important Note: Always check in different areas and especially depressions in the road surface where more SPA60 or P-50 may be present and slower to dry.

11. Apply the tape by hand.

Apply the tape by hand. When splicing is required, do not overlap the material. Use butt splices. (See Figure 18.)

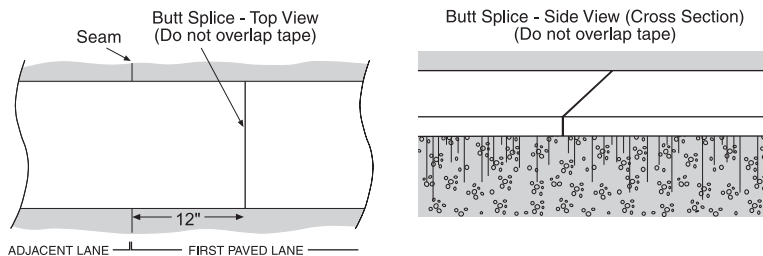

Figure 18

Note: If there is a crack in the road that causes the tape to bridge, lay the tape over the crack, tamp the tape, and then cut the tape one inch from each side of the crack. (See Figure 19.)

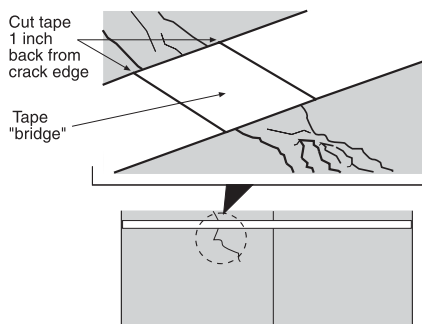

Figure 19

Use this same technique on concrete when the transverse marking is applied over a joint: Cut the tape one inch back from each side of the joint.

For material with liner (Adhesive L Series): Refer to IF 5.8 for liner removal techniques.

Position the marking and peel back the liner. Press the exposed tape down. Slowly remove the rest of the liner as the tape is carefully guided into place. Refer to IF 5.8 for liner removal.

12. Tamp the tape. VERY IMPORTANT!

Tamp the tape thoroughly with the RTC-2 tamper cart with a minimum 200-lb. (90-kg) load making a minimum of six passes. (See Figure 20.)

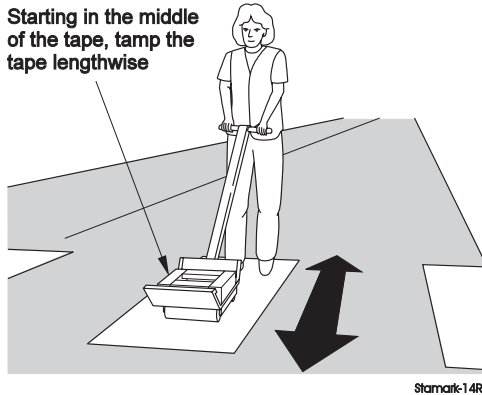

Figure 20

- Do not twist or turn the tamper cart on the tape.
- Make a minimum of six passes (three passes back and forth) over each part of the tape.
- If tape is wider than the roller, more passes will be needed to make sure the entire width of the tape has received the required tamping treatment. **TAMPING IS MOST IMPORTANT STEP OF THE TAPE APPLICATION PROCESS!**
- Make sure all edges are firmly adhered.

Note: Do not use a vehicle tire to tamp transverse markings!

13. Open the road to traffic.

Additional Information

A. Storage

Surface preparation adhesive SPA60 and P-50 must be stored in a cool, dry area indoors. A storage temperature of 40-100°F (4-38°C) is recommended. Use all tape products within one year of receipt. Unopened containers of SPA60 or P-50 must be used within two years of receipt. Check label for expiration date of receipt.

B. Removal

Stamark durable tapes are designed for permanent, non-removal applications. Contact your 3M representative for guidance concerning removal of Stamark tapes.

C. Health and Safety

Read all health hazard, precautionary and first-aid statements found in the Material Safety Data Sheet (MSDS) and/or product label of chemicals prior to handling or use. Also refer to the MSDS for information about the volatile organic compound (VOC) content of chemical products. Consult local regulations and authorities for possible restrictions on product VOC content and/or VOC emission.

Personal protective equipment may be appropriate for safely installing these products in a work zone environment. For example, eye, ear, and respiratory protection may be appropriate during grooving, surface preparation, or for the removal of existing pavement markings. Always follow safe work zone practices.

D. Caution

- Gloves should be worn when using any Stamark tapes to prevent injury to hands.
- Do not use a flame or torch to remove Stamark tapes. Burning may violate local, state or federal air quality regulations. Also, exposing the tape to very high temperatures with the use of a flame or torch could generate emissions that may be harmful to skin, eyes and respiratory system.

Appendix A. Pavement Surface Types

The pavement surface type and age determine which application procedures should be used for Stamark tapes. For pavement types not covered, contact your 3M representative.

A. ASPHALTIC CEMENT CONCRETE (ACC)

Standard Mix Asphalt

A standard mix contains both fine (sand) and large (1/4-inch [6-mm]) aggregate with an asphalt cement binder. Stamark tapes can be inlaid or overlaid on this surface.

Open Grade Friction Course

An open grade friction course mix consists of only large aggregate, up to 3/4 inches (19 mm), with an asphalt cement binder. Stamark tapes can be inlaid or overlaid on this surface. Refer to the inlay application section of this folder for further explanation, beginning on page 4.

Chip Seal

A chip seal is achieved by spraying a hot asphalt emulsion onto an existing surface and then covering it with a 1/4-inch (6.4-mm) aggregate. Excess aggregate is removed after several days of exposure to traffic. Stamark tapes can be overlaid on this surface after the loose aggregate is removed and the surface has cured.

Slurry Seal

A slurry seal is a hot asphalt emulsion that is sprayed onto an existing surface, as a top coat dressing only. No aggregate is added. Stamark tape can be overlaid on this surface after the road has been open to traffic for three days.

Recycled Asphalt

This road surface consists of an existing asphalt that is removed through milling or grinding, reprocessed and then reapplied. Stamark tape can be inlaid or overlaid on this surface.

Rubberized Asphalt

Rubberized asphalt mixes contain additives designed to increase durability. The mix can be either a “standard mix” or an “open grade friction course” mix. Stamark tape can be applied as noted under the appropriate headings in this information folder.

B. PORTLAND CEMENT CONCRETE (PCC)

New Concrete

During construction, the new surface is often brushed or grooved (tined). Concrete that has been open to traffic less than 90 days must have the curing compound removed before applying Stamark tapes or surface

preparation adhesive. Sandblasting is the method commonly used to remove curing compound from new concrete. Other methods, such as shot-blasting or hydroblasting, can also be used. In the case of hydroblasting, the pavement must be allowed to dry before the surface preparation adhesive and tape are applied.

Old Concrete

Old concrete is a PCC surface that has been open to traffic for more than one year and is showing signs of wear. Often this surface is smooth with large amounts of exposed, polished aggregate. Stamark tape can be overlaid using a surface preparation adhesive. The old concrete surface may require texturing prior to surface preparation adhesive and tape application. Contact a technical service representative at 1-800-553-1380 for additional information.

Appendix B. Surface Preparation Adhesives

Two surface preparation adhesives are commonly available for application of Stamark pavement marking tapes: surface preparation adhesive SPA60 and P-50.

A. Surface Preparation Adhesive SPA60

SPA60 can be used in a five gallon pail or spray cylinder for long line and transverse applications. SPA60 can be applied using a spray or roller method.

B. Surface Preparation Adhesive P-50

P-50 sprayable adhesive is applied using the PS-14 spray applicator. It is designed to be used as a surface preparation adhesive for long-line applications. It is also applied using a long-handled, thick (3/8 inch [0.95cm]) nap paint roller with a solvent resistant core.

C. Coverage for SPA60 and P-50 Adhesives

See Chart 3 below to determine how much adhesive you need to cover a specific area.

Adhesive Type	One Coat
SPA60 Roller Application	SPA60 roller application recommends one even coat on the road surface of adhesive series A series tapes. Please calculate the square footage per road surface and back of the tape. SPA60 Coverage of 1500 sq. ft. per cylinder (mini 26 lbs). 3000 linear feet per cylinder for 4-inch tape (spraying 6" wide SPA60). Coverage of 225 sq. ft. per gallon. 450 lineal feet per gallon for 4-inch tape (spraying 6 inches wide SPA60). 337.5 lineal feet per gallon for 6-inch tape (spraying 8 inches wide SPA60.)
P-50 Surface Preparation Adhesive Spray Application	P-50 Coverage of 225 sq. ft. per gallon. 450 lineal feet per gallon for 4-inch tape (spraying 6 inches wide P-50). 337.5 lineal feet per gallon for 6 inch tape (spraying 8 inches wide P-50.)
P-50 Roll Application	75 sq. ft./gallon (1.8 sq. m/liter) (3/8 inch Nap) metric

Appendix C. Road Type Surface Preparation Adhesive Application Recommendations

Road lanes are typically exposed to different levels of traffic shear exposure. Road lanes that are exposed to a high frequency of high shear turning; especially by trucks and other large vehicles require use of surface preparation adhesive SPA60 or P-50 for application of Stamark pavement marking tapes. The following table summarizes the product and surface preparation adhesive application recommendations by shear condition:

Shear Level		Product and Adhesive Recommendation
	Very High Shear	Stamark Tape “N” Series Using the SPA60 spray cylinder
	High Shear	Stamark Tape Adhesive Series “A” and “L” Stamark Series Use One Coat of SPA60 or P50
	Moderate Shear	Stamark Tape “A” and “L” Stamark Series Use SPA60 or P-50
	Low Shear	Stamark Tape “A” and “L” Series No surface preparation adhesive required unless otherwise directed by 3M technical service.
Within the Climate Guide and road condition recommendations		

Important Note: Refer to **Overlay Application of Transverse Markings** sections starting on page 13. Contact 3M Technical Service at 1-800-553-1380 for questions on SPA60 or P-50 applications.

Literature Reference

For additional information on 3M™ Stamark™ Pavement Marking Tapes, application recommendations, or 3M application equipment, refer to the following publications:

- Product Bulletin 380AW 3M™ Stamark™ High Performance All Weather Tape Series 380AW
- Product Bulletin 380I ES 3M™ Stamark™ High Performance Tape Series 380IES
- Product Bulletin 380I-5ES 3M™ Stamark™ High Performance Tape Series 380I-5ES
- Product Bulletin 270 ES 3M™ Stamark™ Pavement Marking Tape 270ES
- Product Bulletin 390 3M™ Stamark™ High Performance Tape Series 390
- Product Bulletin 390-5 3M™ Stamark™ High Performance Contrast Marking Tape
- Information Folder 5.2 Highway Tape Applicator (HTA)
- Information Folder 5.8 Application of 3M™ Stamark™ Precut Symbols and Legends
- Information Folder 5.17 3M™ Stamark™ Surface Preparation Adhesive P-50
- Information Folder 5.18 Guidelines for Pavement Marking Applications in Grooved Pavement Surfaces
- Information Folder 5.21 3M Stamark Surface Preparation Adhesive SPA-60
- 3M Climate Guide Climate Guide for 3M™ Stamark™ Pavement Marking Tapes
- 3M Road Surface Guide Road Surface Guide for 3M™ Stamark™ Pavement Marking Tapes.

For information or assistance call:

1-877-777-3571

In Canada call:

1-800-265-1840

Internet:

www.3M.com/roadwaysafety

3M and Stamark are trademarks of 3M. Used under license in Canada.

3M assumes no responsibility for any injury, loss or damage arising out of the use of a product that is not of our manufacture. Where reference is made in literature to a commercially available product, made by another manufacturer, it shall be the user's responsibility to ascertain the precautionary measures for its use outlined by the manufacturer..

Important Notice

All statements, technical information and recommendations contained herein are based on tests we believe to be reliable, but the accuracy or completeness thereof is not guaranteed, and the following is made in lieu of all warranties, or conditions express or implied. Seller's and manufacturer's only obligation shall be to replace such quantity of the product proved to be defective. Neither seller nor manufacturer shall be liable for any injury, loss or damage, direct, special or consequential, arising out of the use of or the inability to use the product. Before using, user shall determine the suitability of the product for his/her intended use, and user assumes all risk and liability whatsoever in connection therewith. Statements or recommendations not contained herein shall have no force or effect unless in an agreement signed by officers of seller and manufacturer.



Traffic Safety and Security Division

3M Center, Building 0225-04-N-14
St. Paul, MN 55144-1000 USA

Phone 1-800-553-1380

Web 3M.com/roadwaysafety

Please recycle. Printed in USA © 3M 2015.
All rights reserved.