

**1**  
a501  
section detail  
1 1/2"=1'-0"

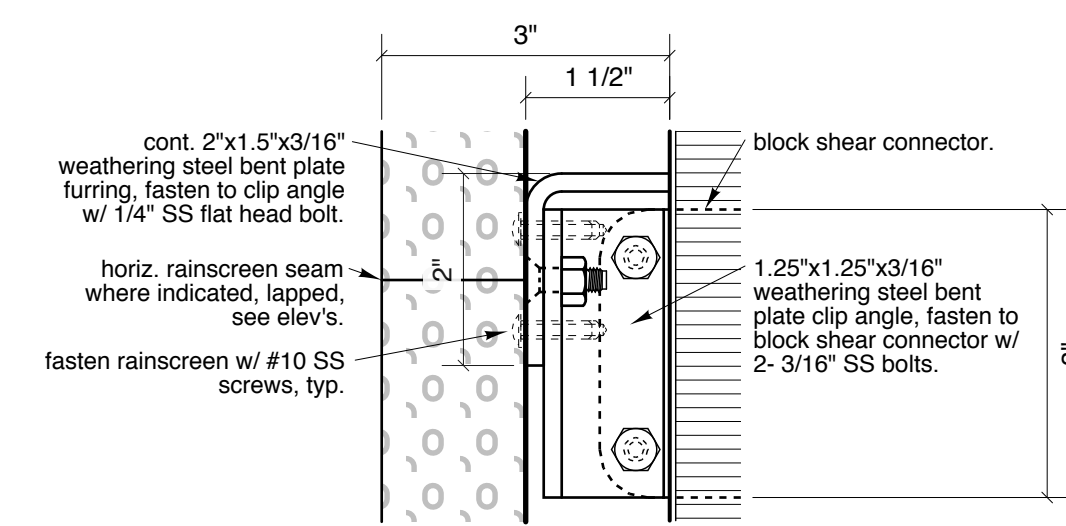

**2**  
a501  
section detail  
6"=1'-0"

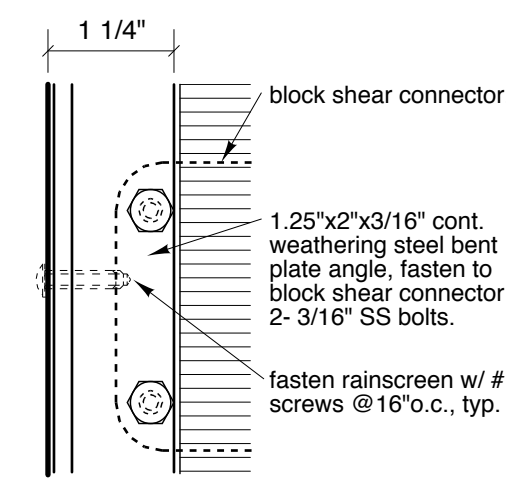

**3**  
a501  
section detail  
6"=1'-0"

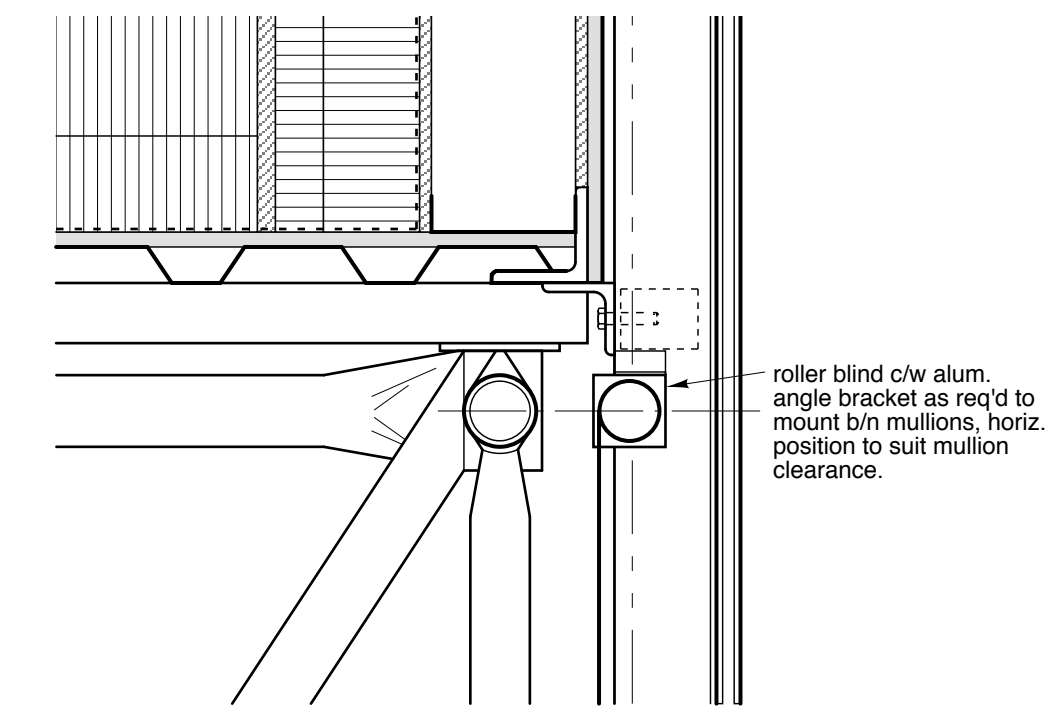

**4**  
a501  
section detail  
1 1/2"=1'-0"

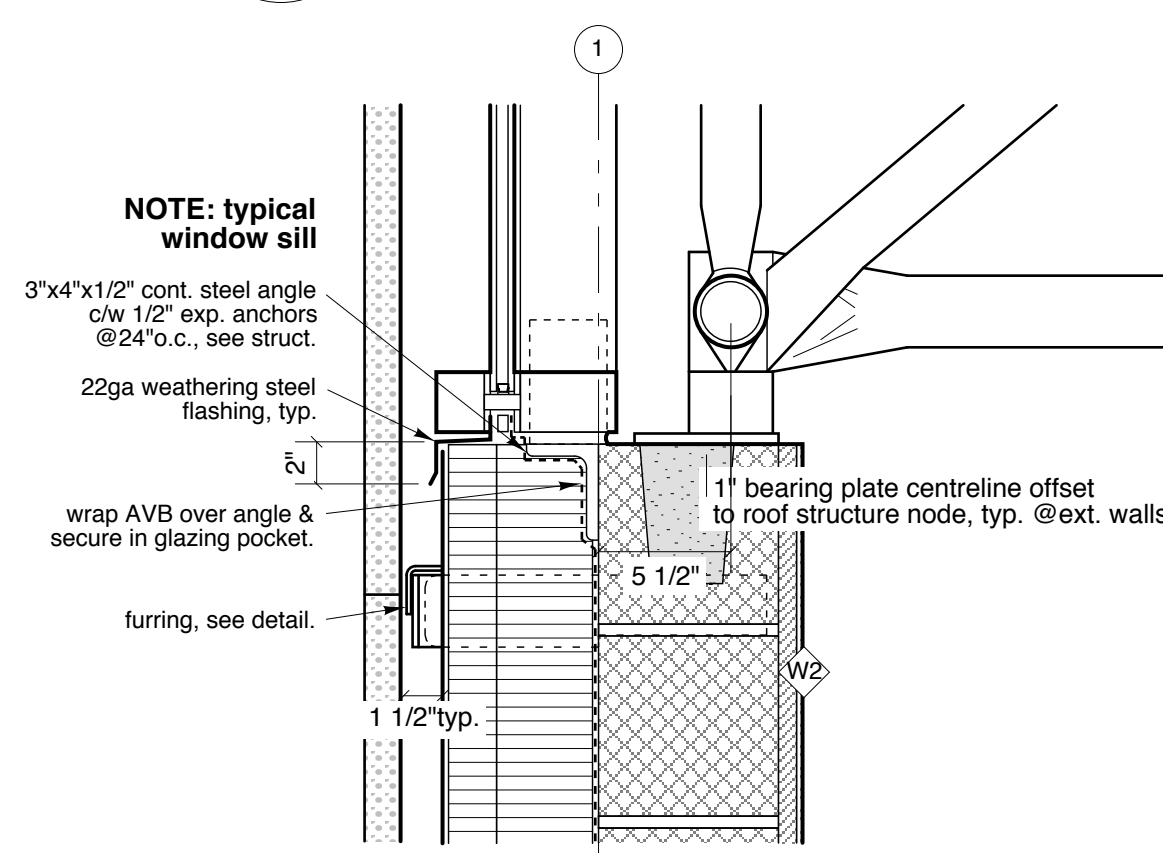

**5**  
a501  
section detail  
1 1/2"=1'-0"

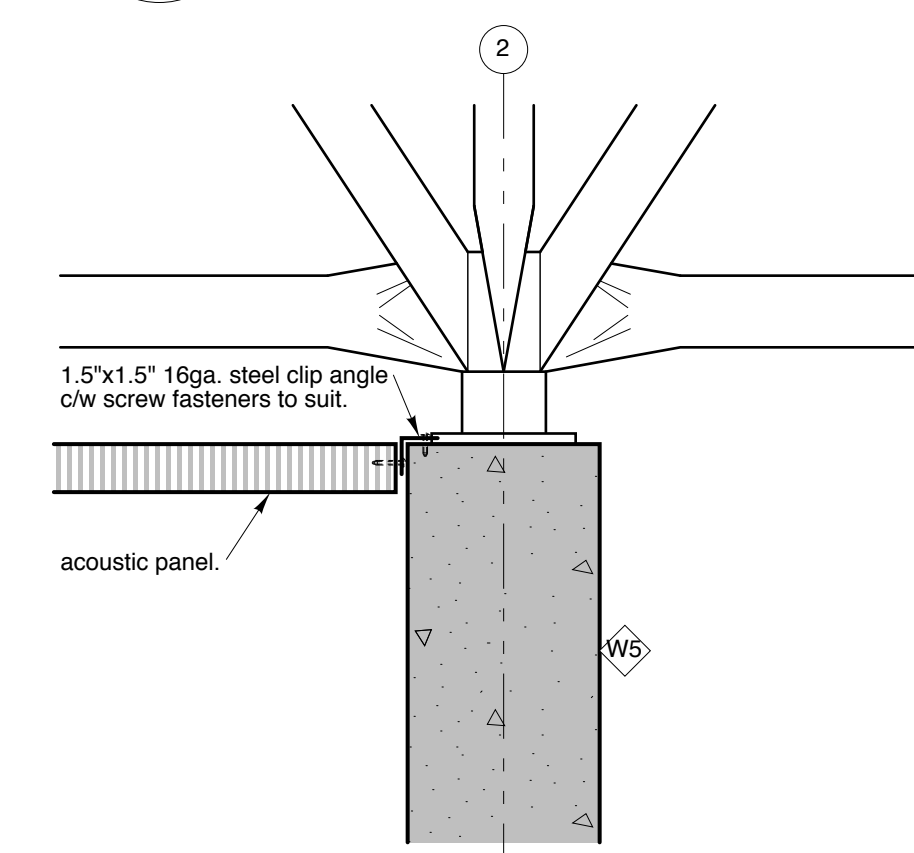

**6**  
a501  
section detail  
1 1/2"=1'-0"

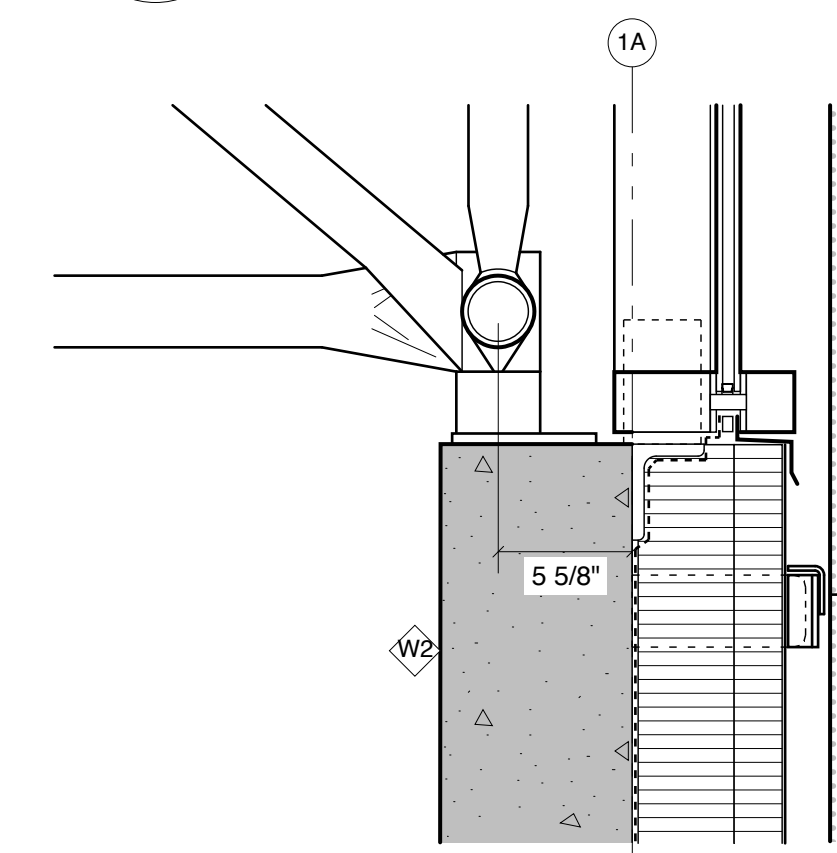

**7**  
a501  
section detail  
1 1/2"=1'-0"

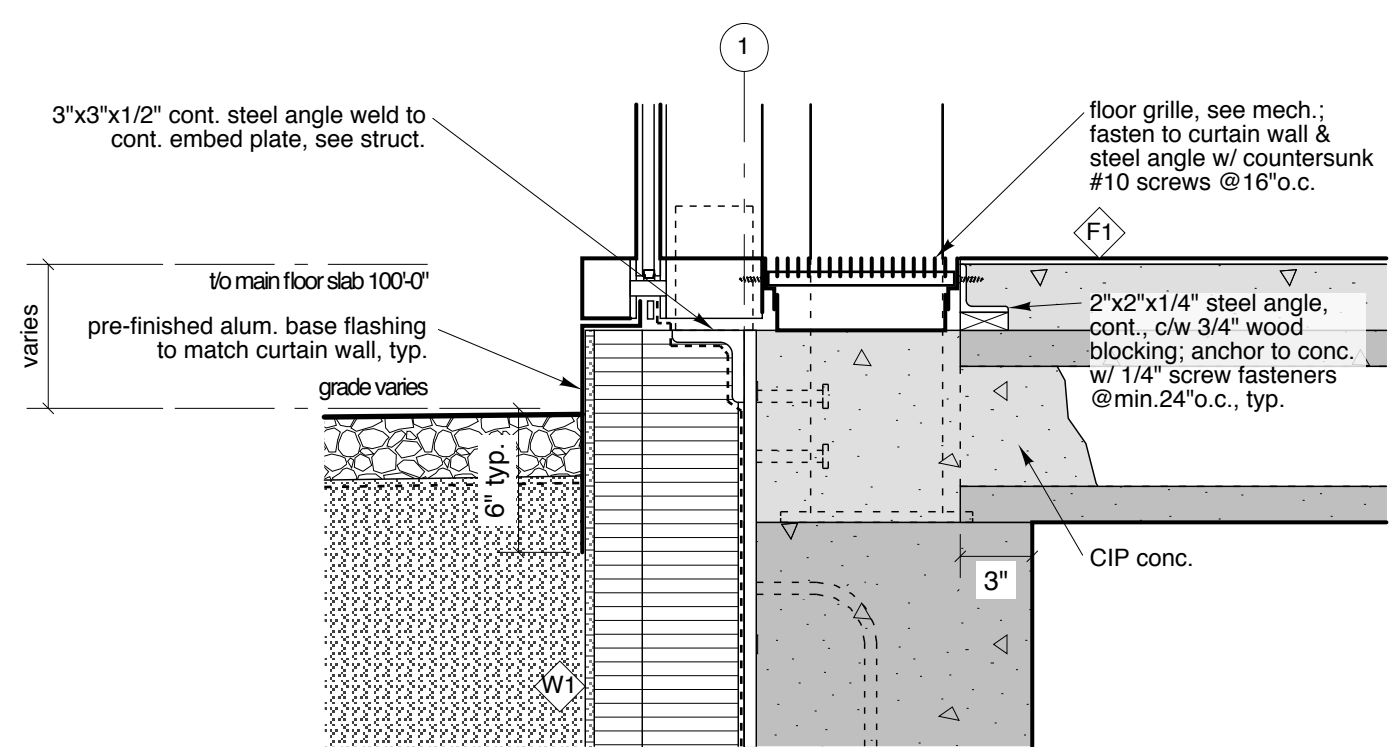

**8**  
a501  
section detail  
1 1/2"=1'-0"

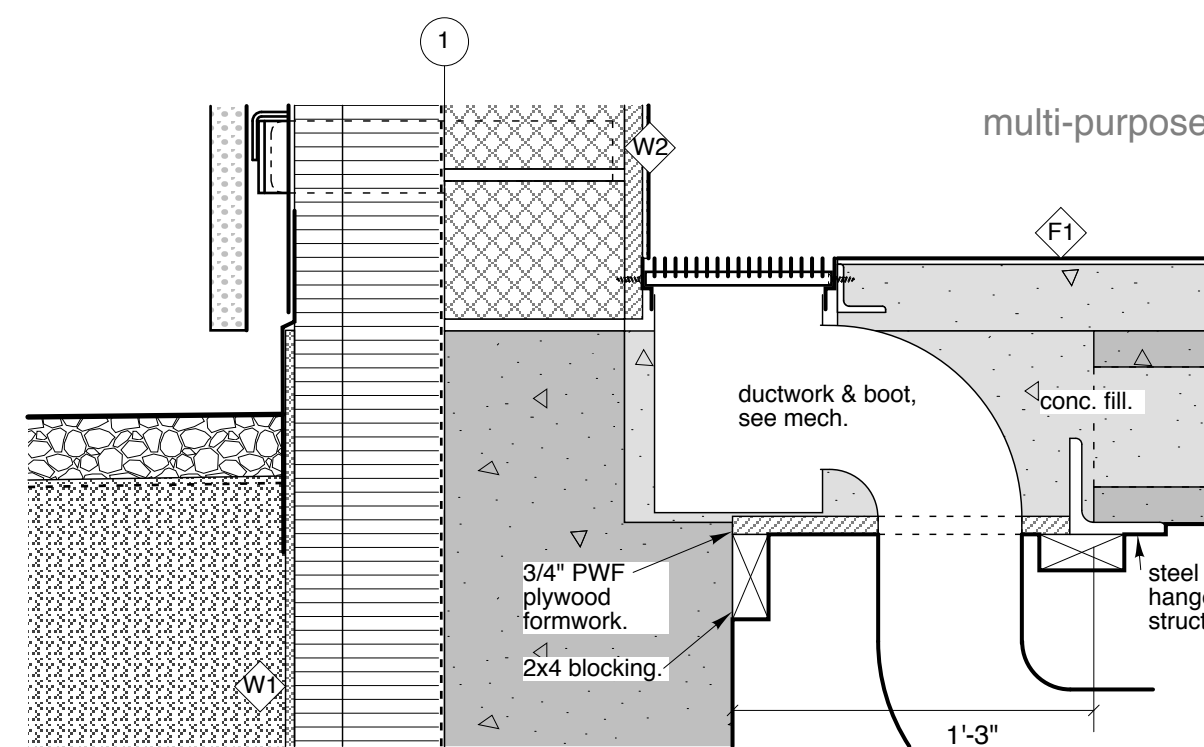

**9**  
a501  
section detail  
1 1/2"=1'-0"

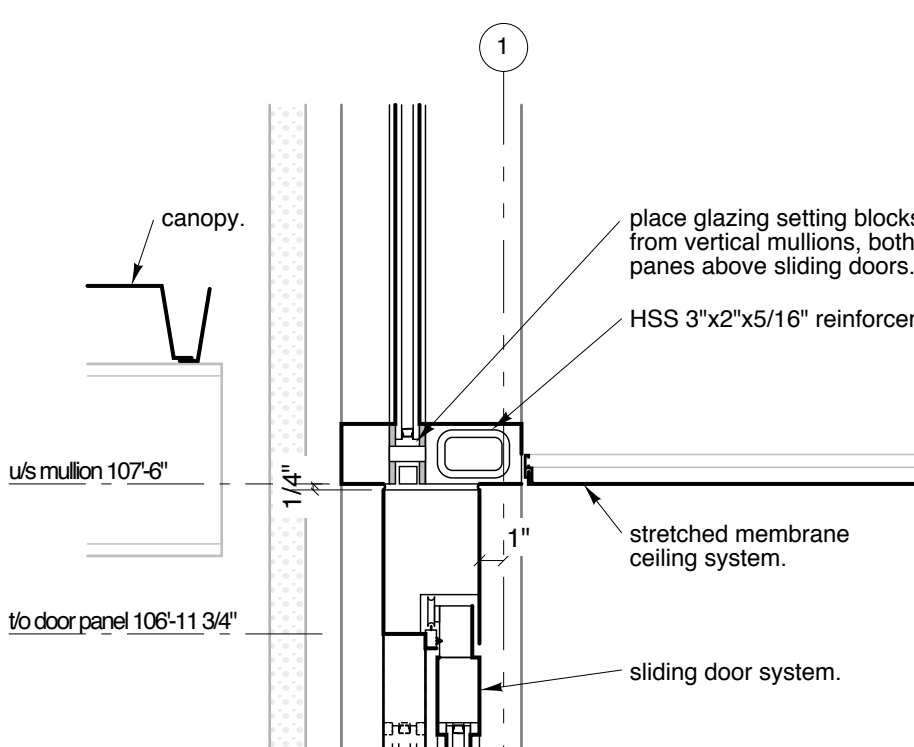

**10**  
a501  
section detail  
1 1/2"=1'-0"

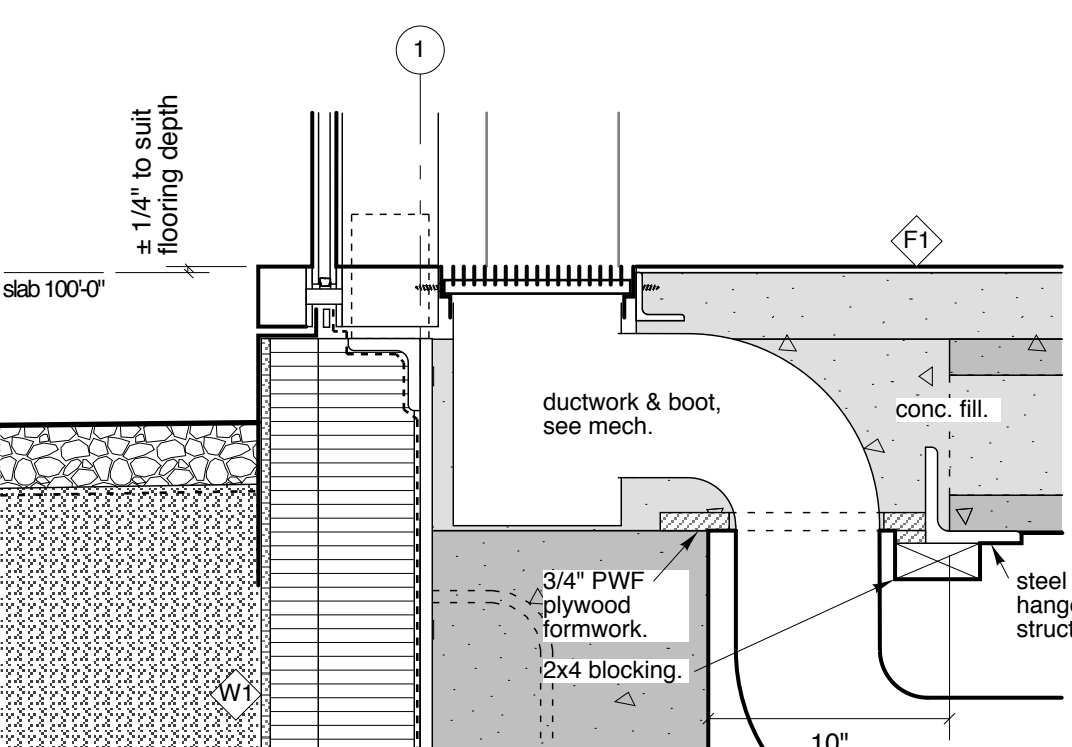
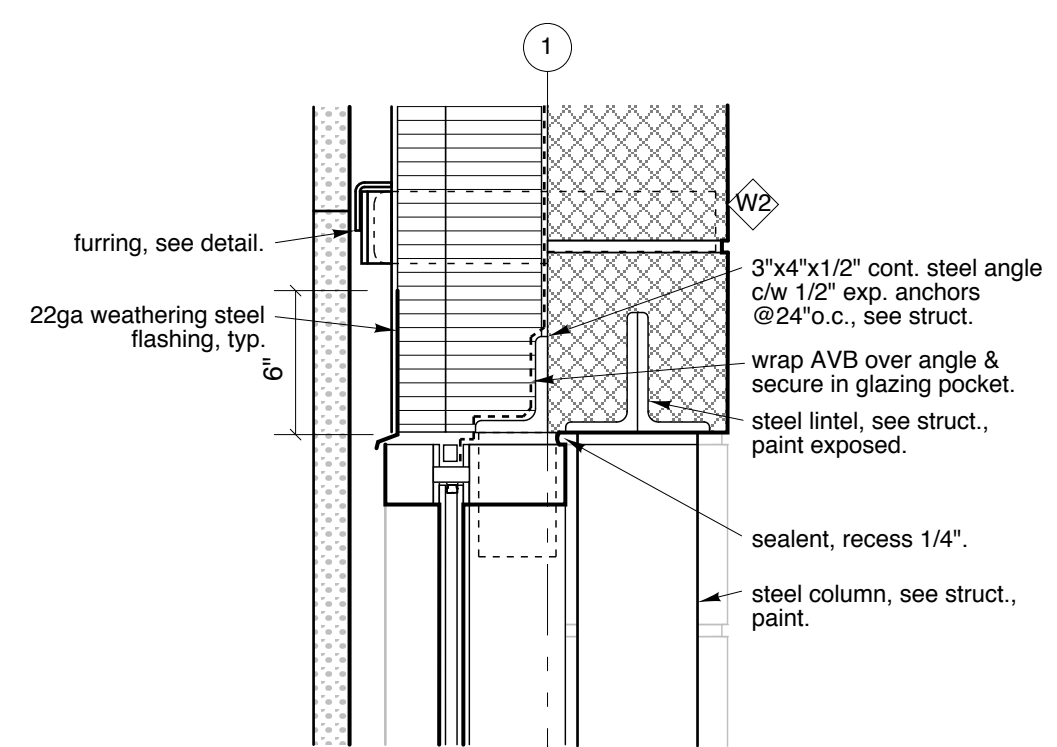

**11**  
a501  
section detail  
1 1/2"=1'-0"

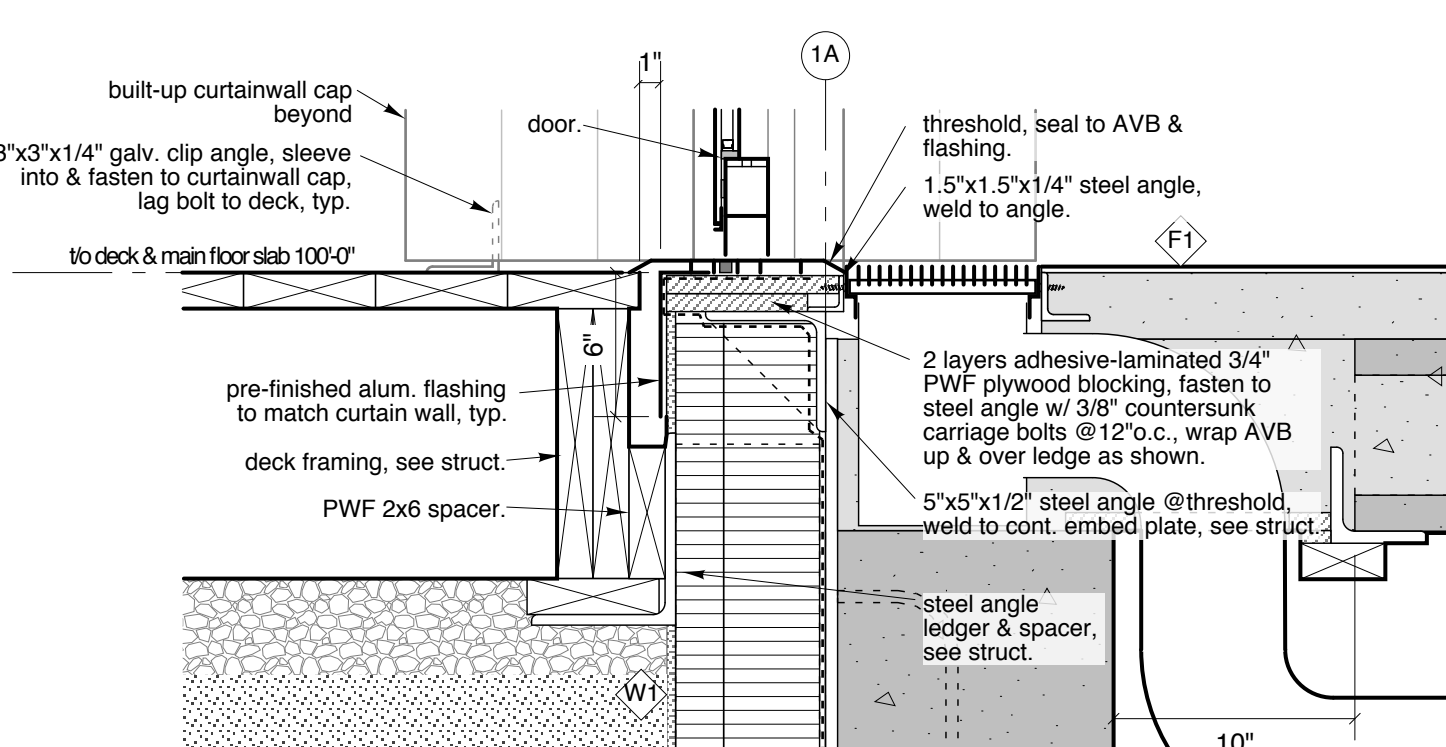

**12**  
a501  
section detail  
1 1/2"=1'-0"

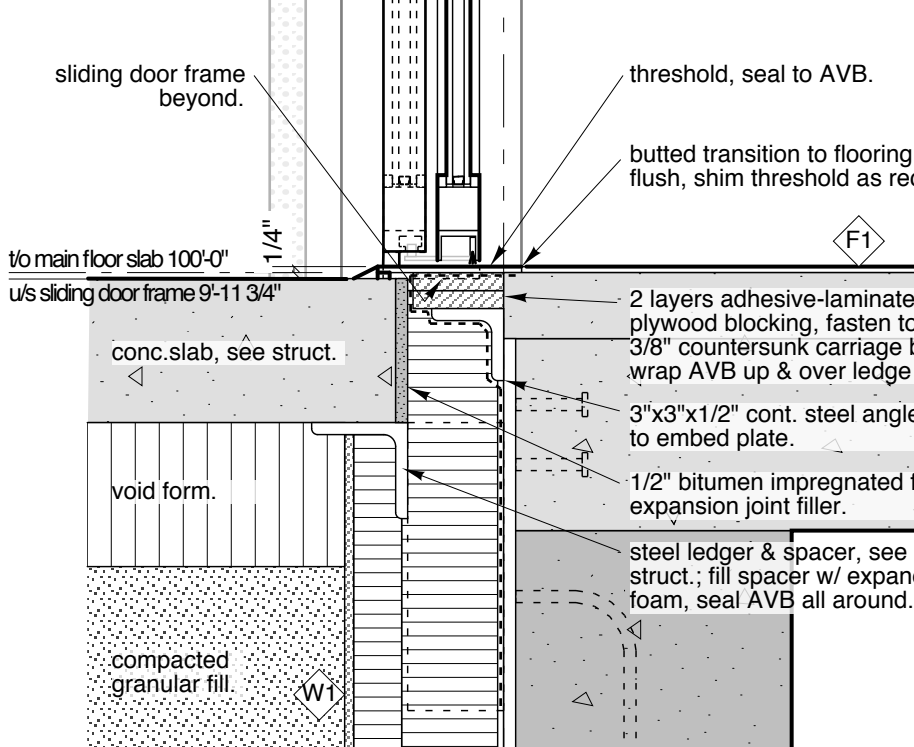

**13**  
a501  
section detail  
1 1/2"=1'-0"

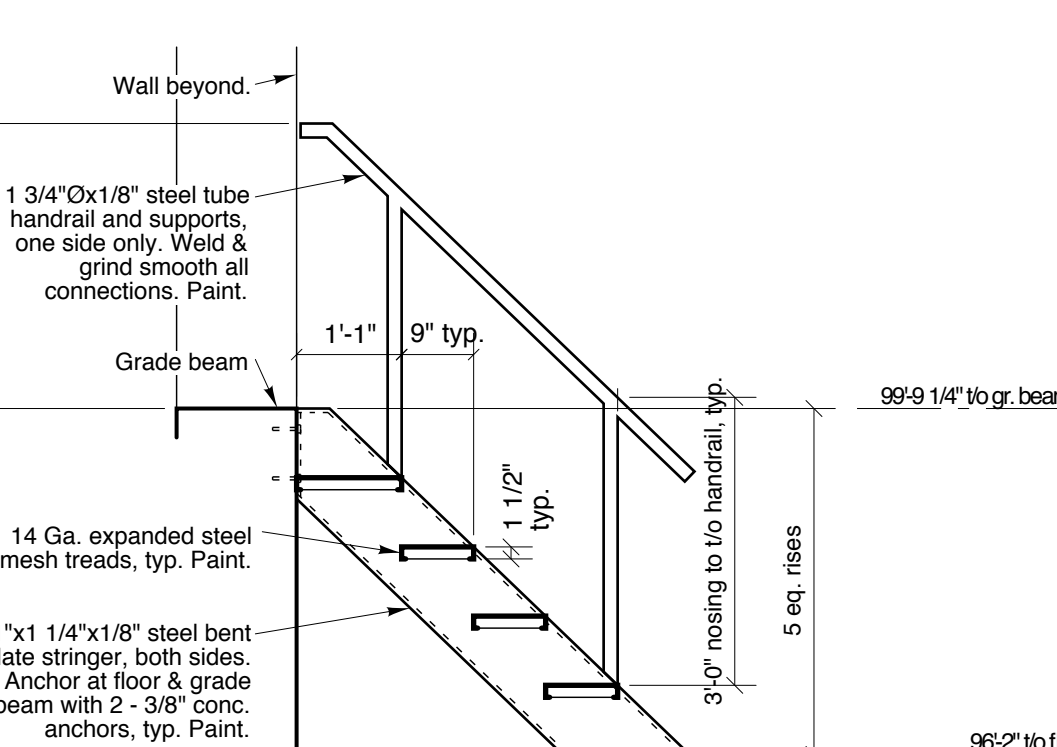

**14**  
a501  
stair detail  
1/2"=1'-0"



Issued for Construction: March 28, 2016

NOTES:  
THIS DRAWING IS THE EXCLUSIVE PROPERTY OF HIS ARCHITECTURE AND DAVID PENNER ARCHITECT AND MAY NOT BE REPRODUCED AND/OR USED IN ANY MANNER WITHOUT THEIR EXPRESSED WRITTEN PERMISSION. THE GENERAL CONTRACTOR AND MATERIALS SUPPLIER/S SHALL CHECK ALL DIMENSIONS AND INFORMATION ON THIS DRAWING AND REPORT ANY DISCREPANCIES PRIOR TO COMMENCEMENT OF WORK. DO NOT SCALE THIS DRAWING.



CITY OF WINNIPEG - PLANNING, PROPERTY & DEVELOPMENT DEPARTMENT  
MUNICIPAL ACCOMMODATIONS DIVISION  
3rd FLOOR - 65 GARRY ST., WPG, R3C 4K4

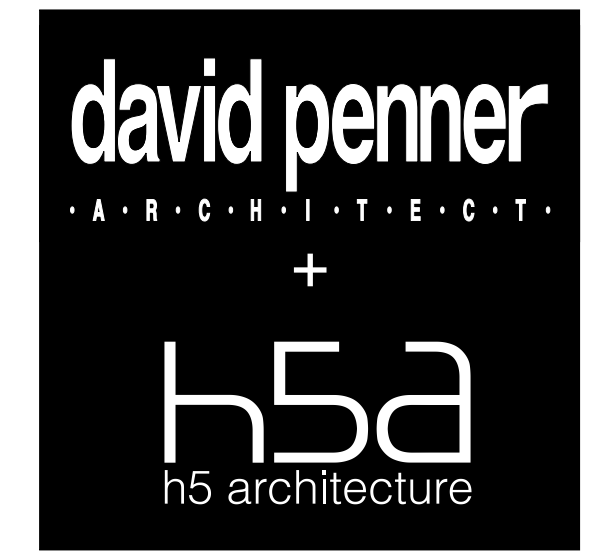

David Penner, 204.475.8978  
Helio Rodrigues, 204.774.0012  
120 Yale Avenue, Winnipeg, MB, R3M 0L7

**PROJECT**  
Windsor Park Library  
**ADDRESS**  
1201 Archibald Street  
**DATE**  
March 28, 2016  
**SCALE**  
as noted

section details  
**a.501**