

A1 SIZE - 594mm x 841mm

© CH2M HILL 2015. ALL RIGHTS RESERVED.

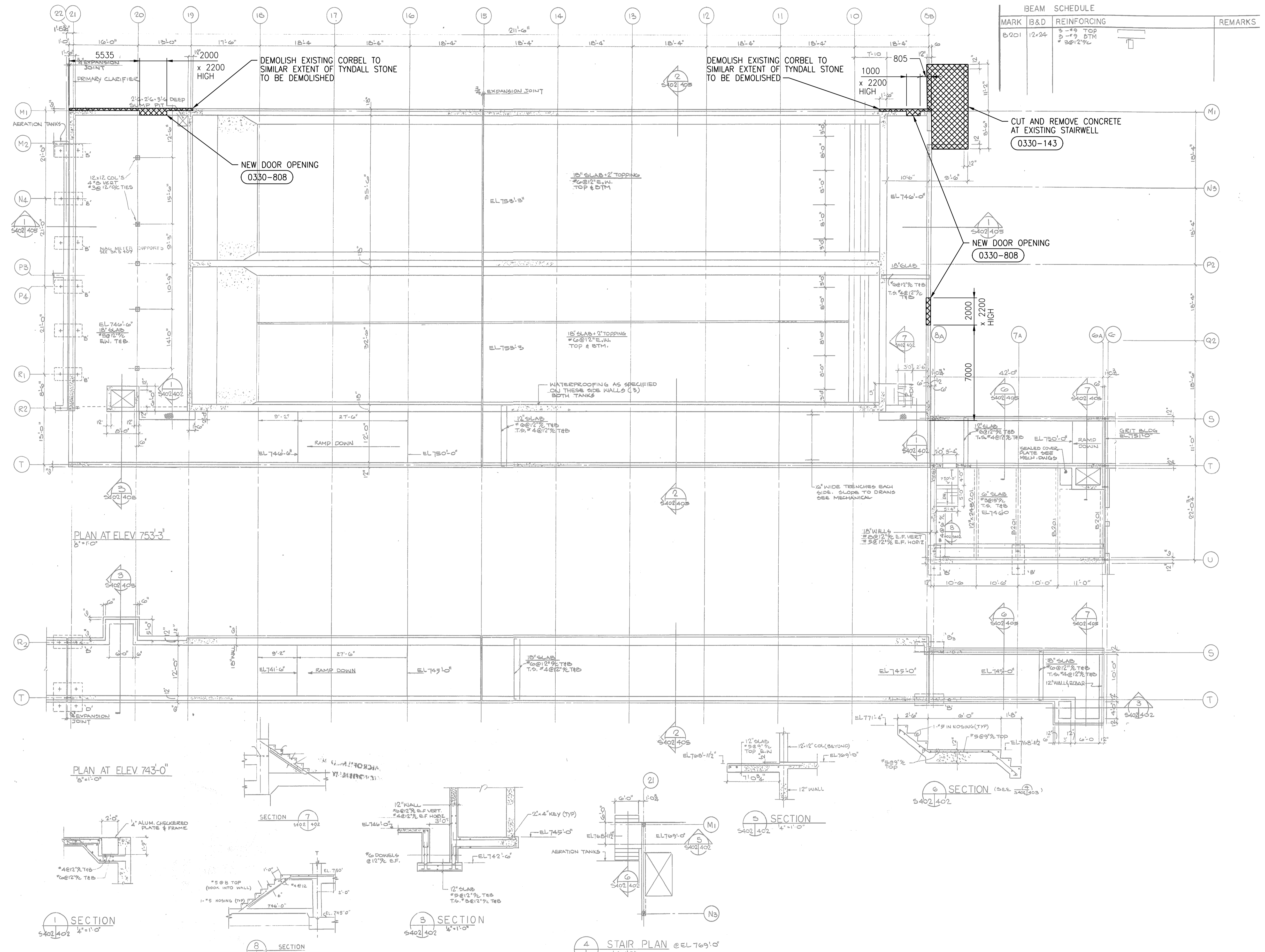

BEAM SCHEDULE			
MARK	B&D	REINFORCING	REMARKS
B201	12-24	5-#8 TOP 3-#8 BOT 3@12" TYP	

PLAN AT ELEV 753'-3"

PLAN AT ELEV 743'-0"

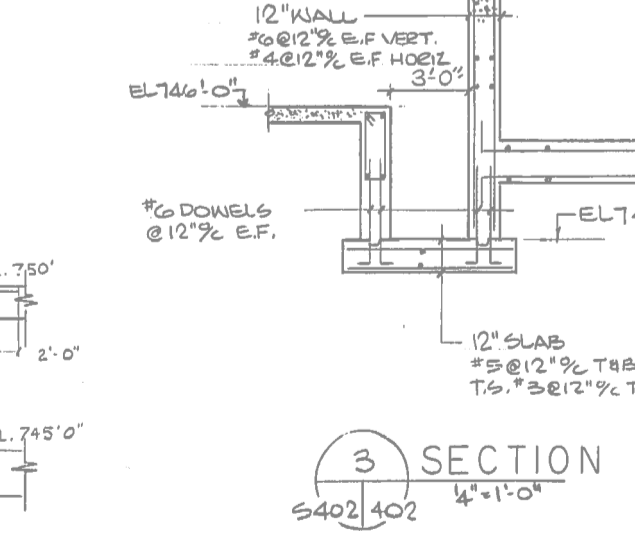
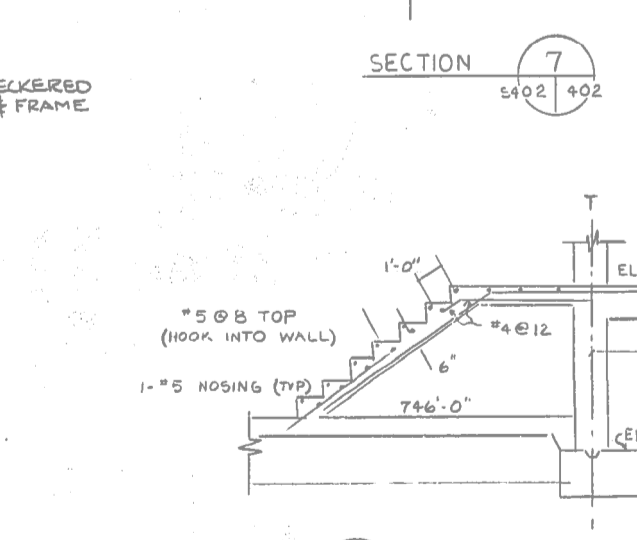
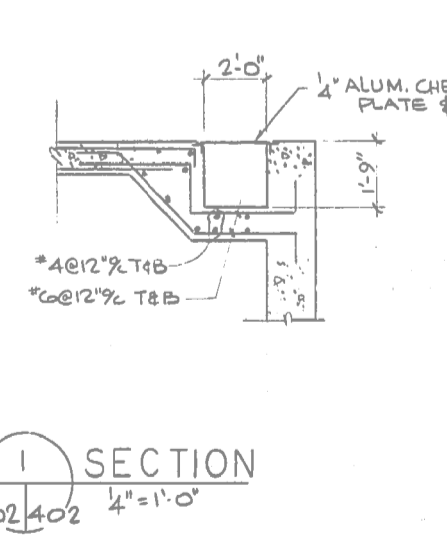
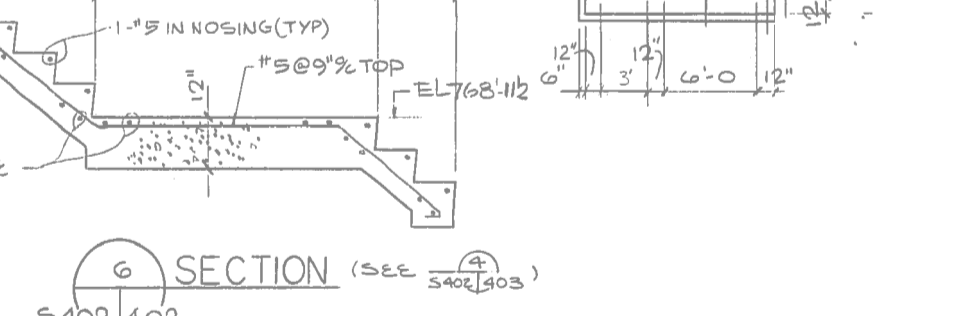
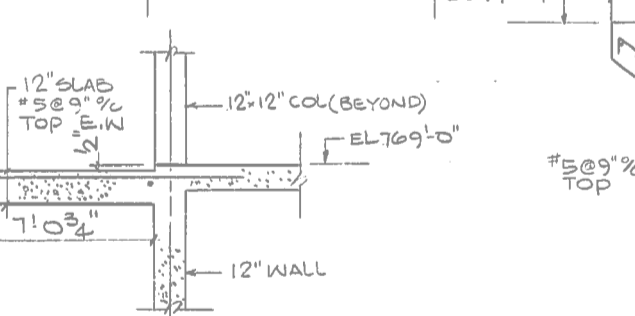
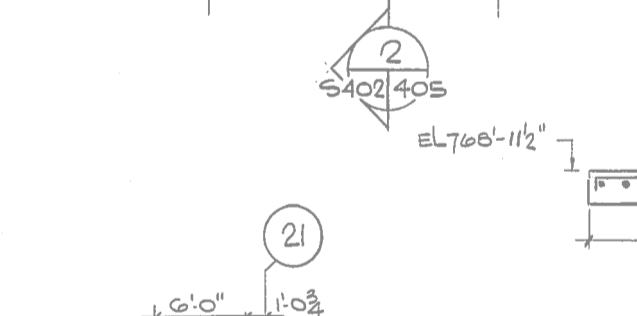
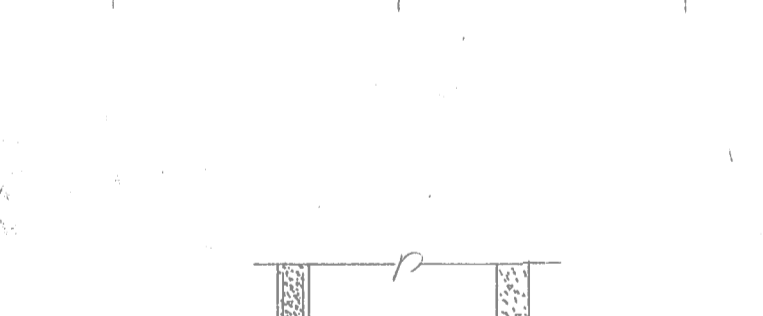
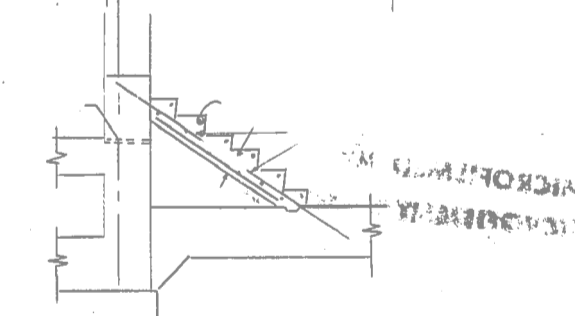

**GALLERY AND PLANT BY-PASS PLAN**  
NTS

**APEGM**  
Certificate of Authorization  
CH2M HILL Canada Ltd.  
No. 1441

NO.	REVISIONS	DATE	DESIGN	CHECK
00	ISSUED FOR TENDER	08/2015	G.O. J.C.	

**CH2MHILL.**

SNC-LAVALIN

DESIGNED BY: E. LUI    CHECKED BY: R. PARIKH  
 DRAWN BY: G. OMORI    APPROVED BY: E. LUI  
 SCALE: NTS    ISSUED FOR CONSTRUCTION BY: T. TURZAK  
 DATE: 2015/08/13    DATE: 2015/08/13  
 CONSULTANT NO.: 474248

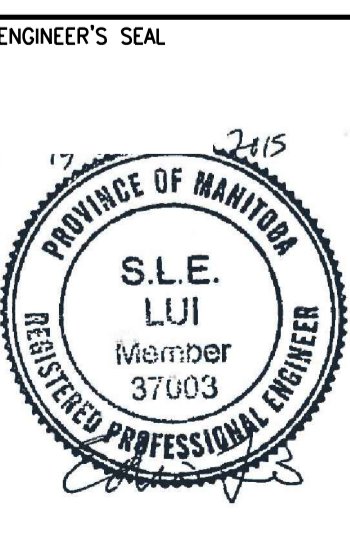

SEALING ARCHITECT OR ENGINEER ACCEPTS RESPONSIBILITY ONLY FOR AREAS IDENTIFIED BY CLOUDING ON THIS DRAWING.

NOTE: THIS DRAWING SUPERSEDES DRAWING SEP-56

THE CITY OF WINNIPEG  
Winnipeg WATER AND WASTE DEPARTMENT

SOUTH END WATER POLLUTION CONTROL CENTRE  
SEWPC UPGRADING/EXPANSION PROJECT  
STRUCTURAL  
PRIMARY CLARIFIERS  
GALLERY AND PLANT BY-PASS PLAN

CITY DRAWING NUMBER: 1-0102-SGAD-P050    SHEET: 00    REV:    SIZE: A1

