

**NOTES:**

- ISOLATE EXISTING HYDRO POLES AS DIRECTED BY CONTRACT ADMINISTRATOR
- RENEW EXISTING APPROACHES AS DIRECTED BY CONTRACT ADMINISTRATOR
- ADDITIONAL EXCAVATION AND INSTALLATION OF SUBGRADE GEOGRID TO BE DETERMINED BY CONTRACT ADMINISTRATOR
- ADJUSTMENTS TO PROPOSED CROSSFALL, WHERE REQUIRED, ARE TO BE DETERMINED BY CONTRACT ADMINISTRATOR TO SUIT EXISTING DRIVEWAYS, APPROACHES, ETC.
- ALL LAND DRAINAGE SEWER EXCAVATION TO BE JETTED, FLOODED AND TAMPED AS PER CW2030-R7

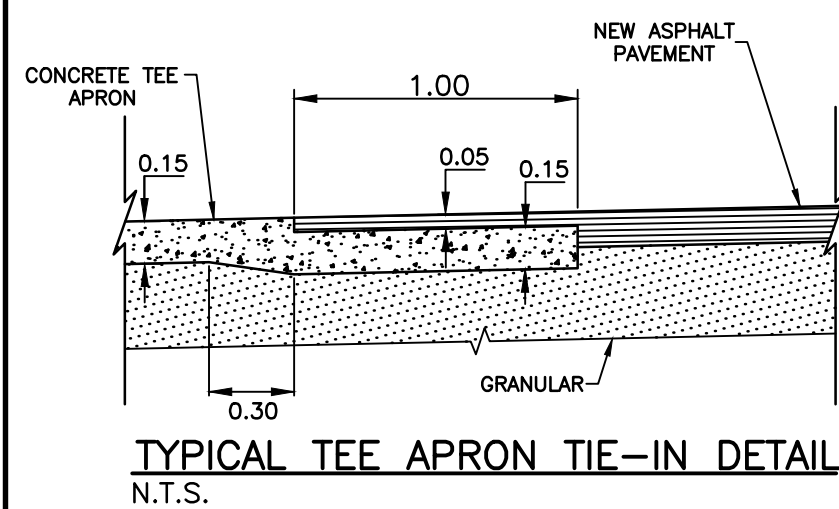

FOR CONTINUATION SEE DWG 141-24150-00-21

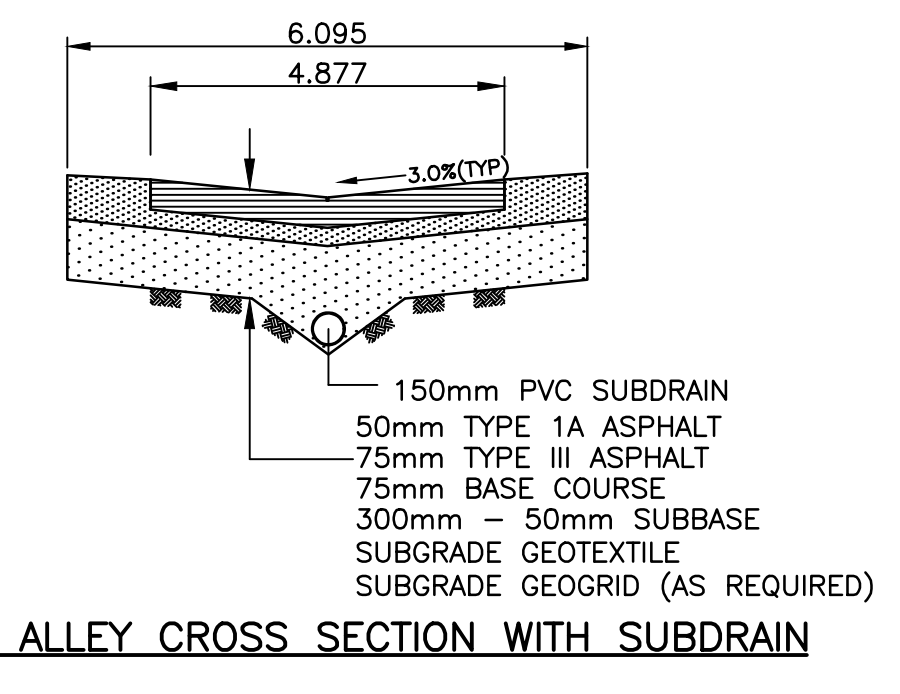
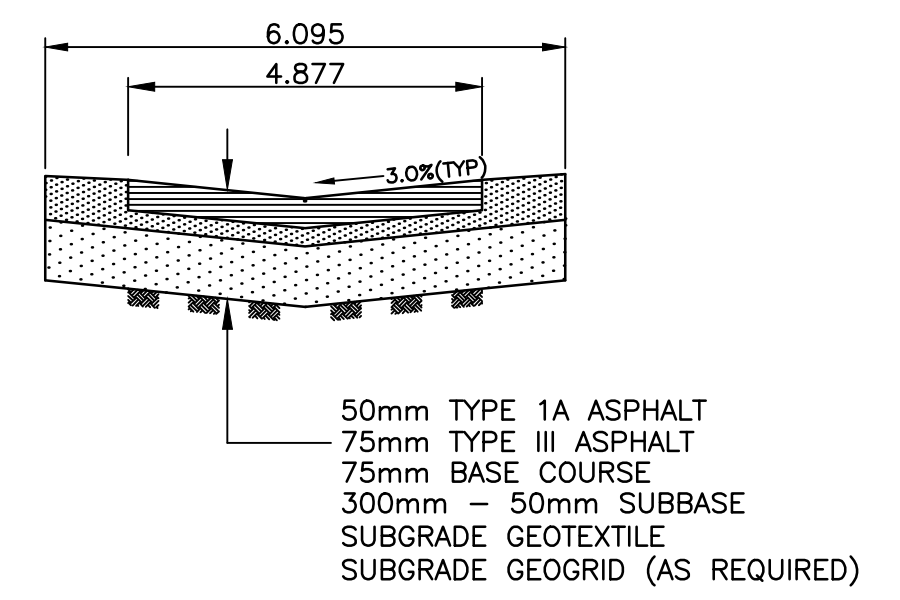
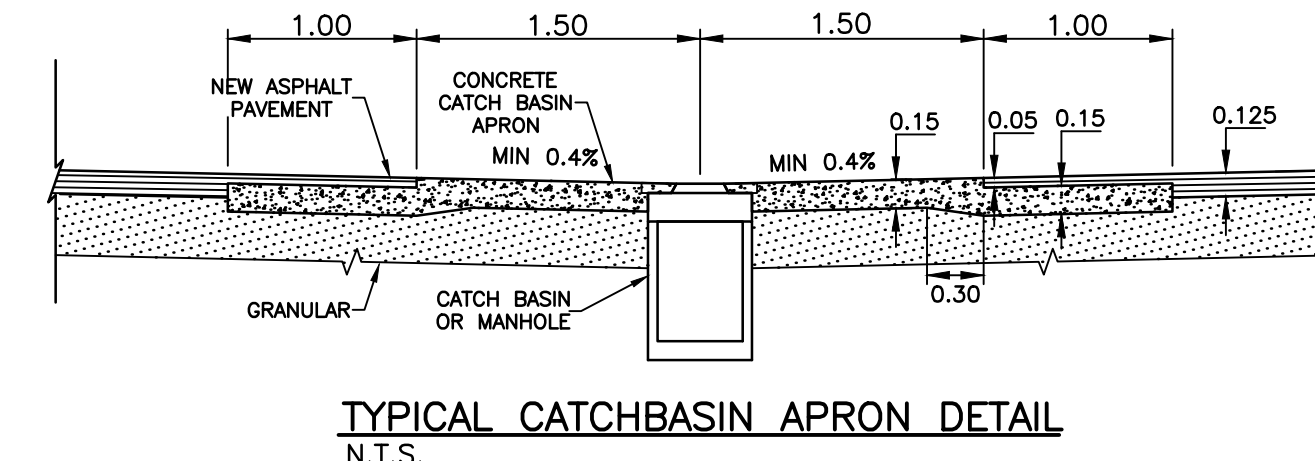
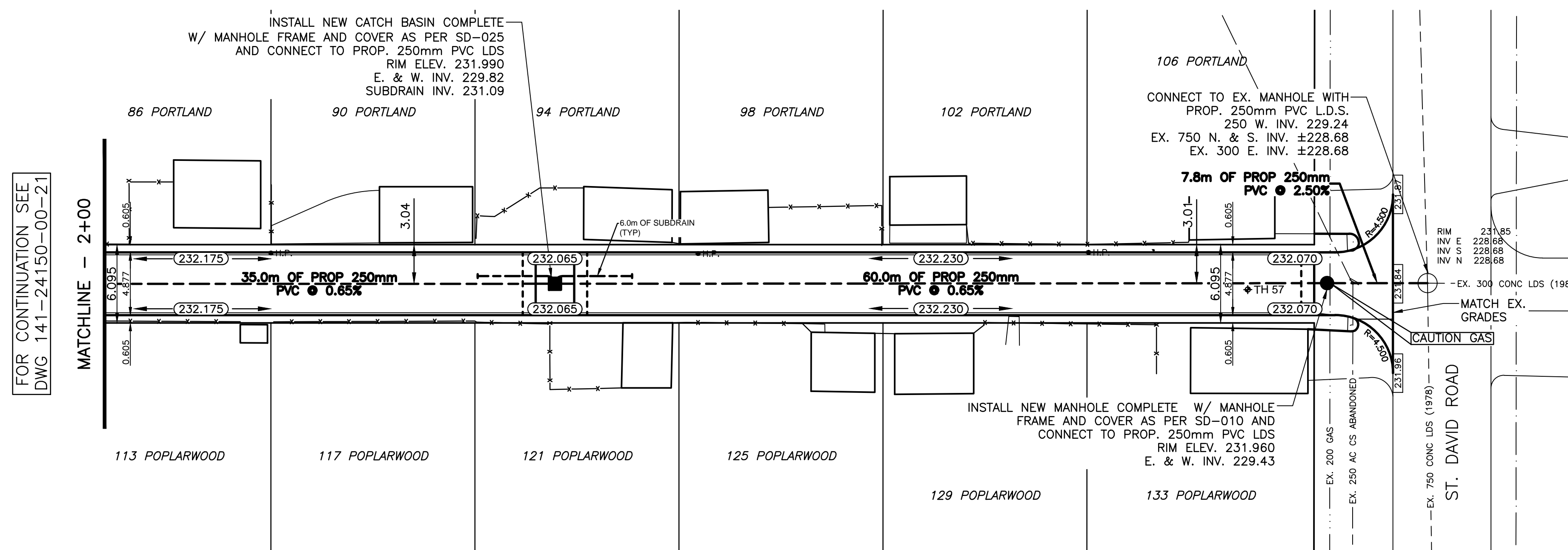

"Description of property limits, and existing and/or proposed features relative to these limits as shown on this drawing do not represent a Legal Survey. WSP makes no representation or guarantee that the property limit information is accurate. WSP accepts no responsibility for damages, if any, suffered by any third party as a result of decisions made or actions based on this drawing."

TEST HOLE DATUM  
 TH57 - N 5523192, E 636176  
 TH58 - N 5523147, E 636099  
 TH59 - N 5523101, E 636013

DESCRIPTION  
 NORTH EAST CORNER OF PORTLAND AVENUE AND NEEPAWA ROAD, TABLET ON TOP OF 0.05M DIAMETER x 2.4M IRON PIPE, 3.0M SOUTH OF NORTH LIMIT OF PORTLAND AVENUE AND 3.0M WEST OF EAST LIMIT OF NEEPAWA ROAD

NOTE:  
 ROW WIDTH 6.095M  
 NEW LANE DESIGN WIDTH 4.877M

EXISTING	LEGEND - PLAN	PROPOSED	EXISTING	LEGEND - PLAN	PROPOSED	EXISTING	LEGEND - PROFILE	PROPOSED
---	WATERMAIN	---	---	M.T.S.	---	---	WATERMAIN	---
⊕	HYDRANT	⊕	---	TRAFFIC SIGNAL	---	⊕	VALVE	⊕
⊕	VALVE	⊕	---	CONCRETE/ASPHALT	---	---	LAND DRAINAGE SEWER	---
⊕	CURB STOP	⊕	---	SIDEWALK	---	---	WASTE WATER SEWER	---
---	WASTE WATER SEWER	---	---	CURB RAMP	---	---	CENTERLINE	---
---	LAND DRAINAGE SEWER	---	---	PROPERTY LINE	---	---	SOUTH & EAST GUTTER	---
---	C.B. LEAD	---	---	ELEVATIONS	---	---	NORTH & WEST GUTTER	---
○	MANHOLE	○	---		---	---	TEST HOLE LOCATION	⊕TH#
□	CATCH BASIN	□	---		---	---	S. & E. PAD/GARG.	---
---	GAS	---	---		---	---	N. & W. PAD/GARG.	---
---	HYDRO	---	---		---	---		---

LOCATION APPROVED UNDERGROUND STRUCTURES

SUPV. U/G STRUCTURES DATE COMMITTEE

NOTE:  
 LOCATION OF UNDERGROUND STRUCTURES AS SHOWN ARE BASED ON THE BEST INFORMATION AVAILABLE BUT NO GUARANTEE IS GIVEN THAT ALL EXISTING UTILITIES ARE SHOWN OR THAT THE GIVEN LOCATIONS ARE EXACT. CONFIRMATION OF EXISTENCE AND EXACT LOCATION OF ALL SERVICES MUST BE OBTAINED FROM THE INDIVIDUAL UTILITIES BEFORE PROCEEDING WITH CONSTRUCTION.

NO.	REVISIONS	DATE	BY
4	ISSUED FOR TENDER	05/08/15	A.B.
3	COW REVIEW AND APPROVAL	05/05/15	A.B.
2	W&W 70% DESIGN REVIEW	03/26/15	A.B.
1	70% DESIGN REVIEW	01/31/15	A.B.

**WSP**  
 1600 BUFFALO PLACE  
 WINNIPEG, MB, R3T 6B8  
 PHONE: 204-477-6650  
 FAX: 204-474-2864  
 WWW.WSPGROUP.COM

DESIGNED BY: A.B.  
 CHECKED BY: S.M.  
 DRAWN BY: A.B.  
 APPROVED BY: I.McK.  
 HOR. SCALE: 1:250  
 VERT. SCALE: 1:25  
 DATE: MAY 2015

ENGINEERS SEAL

CONSULTANT DRAWING NO. 141-24150-00-22

METRIC  
 WHOLE NUMBERS INDICATE MILLIMETRES  
 DECIMALIZED NUMBERS INDICATE METRES

**THE CITY OF WINNIPEG**  
 PUBLIC WORKS DEPARTMENT

**2015 LOCAL IMPROVEMENTS - CONTRACT 1**  
 PORTLAND AVENUE / POPLARWOOD AVENUE LANE

STA. 2+03 TO THE W. GUTTER OF ST. DAVID ROAD ASPHALT PAVEMENT

CITY DRAWING NO. SHEET 2 OF 2  
 426-2015

