

A1 SIZE 894mm x 841mm
PLOT: 6/13/2014 9:33:15 AM
FILE NAME: W140003-T-001_RX.dwg Saved By: dlane

NOTRE DAME AVENUE

RED RIVER COLLEGE
#2055 NOTRE DAME AV

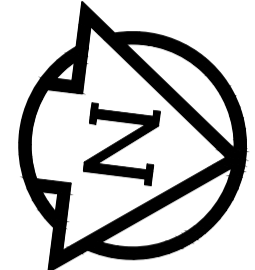

KING EDWARD STREET

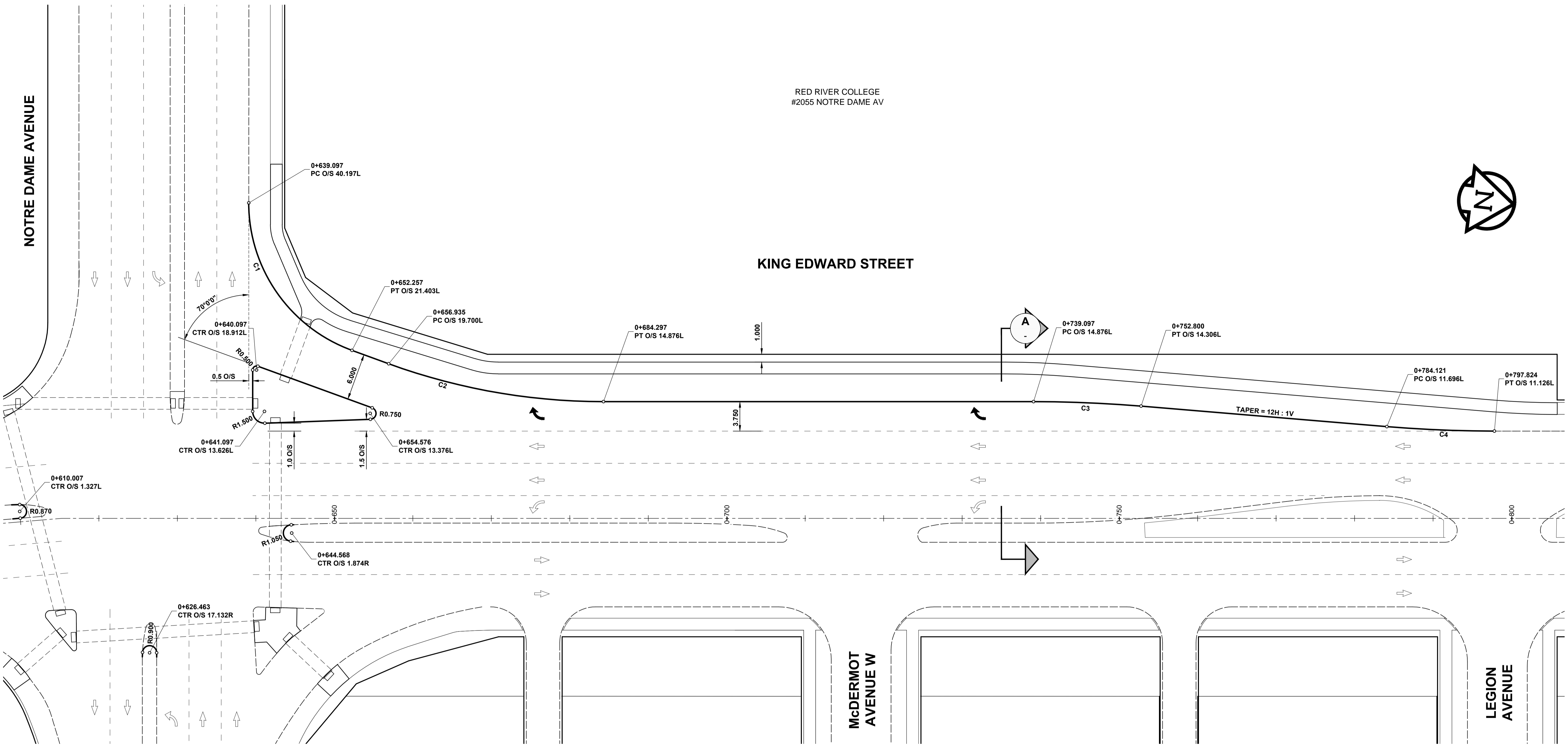

McDERMOT AVENUE W

LEGION AVENUE

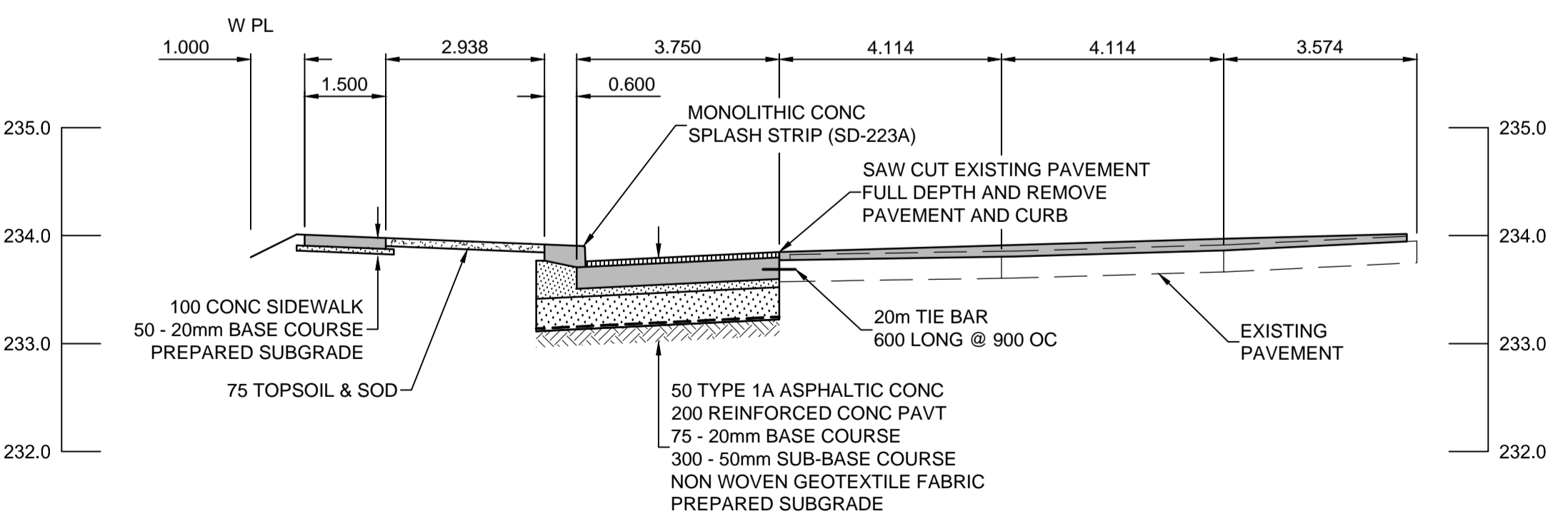

CURVE TABLE				
CURVE	RADIUS	LENGTH	DELTA	TANGENT
C1	20.000	24.435	70°00'00"	14.004
C2	80.000	27.925	20°00'00"	14.106
C3	165.000	13.718	4°45'49"	6.863
C4	165.000	13.718	4°45'49"	6.863

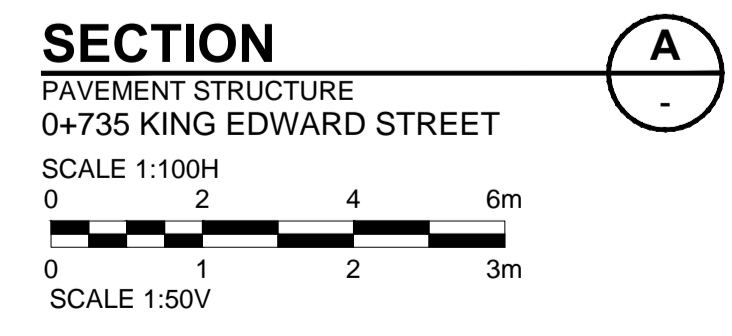
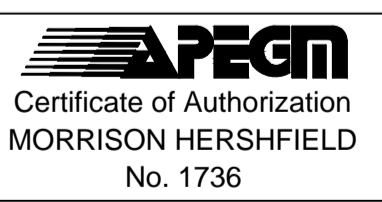

METRIC
WHOLE NUMBERS INDICATE MILLIMETRES
DECIMALIZED NUMBERS INDICATE METRES

LOCATION APPROVED UNDERGROUND STRUCTURES		GBM 23-15 ELEV 234.117	
SUPR. U/G STRUCTURES COMMITTEE	DATE		
NOTE: LOCATION OF UNDERGROUND STRUCTURES AS SHOWN ARE BASED ON THE BEST INFORMATION AVAILABLE. BUT NO GUARANTEE IS GIVEN THAT ALL EXISTING UTILITIES ARE SHOWN OR THAT THE GIVEN LOCATIONS ARE EXACT. CONFIRMATION OF EXISTENCE AND EXACT LOCATION OF ALL SERVICES MUST BE OBTAINED FROM THE INDIVIDUAL UTILITIES BEFORE PROCEEDING WITH CONSTRUCTION.			
0	ISSUED FOR CONSTRUCTION	14/06/12	RPB
No.	REVISIONS	YYMMDD	BY

DESIGNED BY RPB		CHECKED BY WRJ	
DRAWN BY DID/DML		APPROVED BY BWB	
HOR. SCALE	1:250	RELEASED FOR CONSTRUCTION	BTX
VERT. SCALE	1:10	DATE	June 13/14
DATE	14/04/04	DATE	

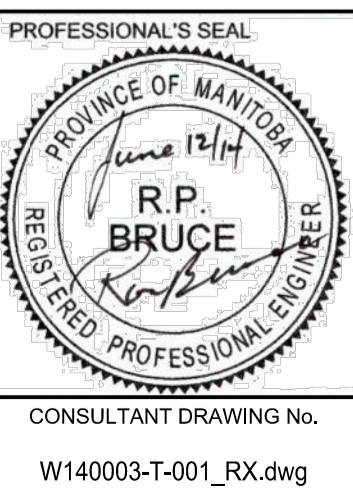

THE CITY OF WINNIPEG
PUBLIC WORKS DEPARTMENT
ENGINEERING DIVISION

2014 REGIONAL STREET RENEWAL PACKAGE
KING EDWARD STREET SOUTHBOUND & CENTURY STREET NORTHBOUND
HORIZONTAL GEOMETRY
S/B KING EDWARD STREET TO W/B NOTRE DAME AVENUE

CITY DRAWING NUMBER P-3358-1
SHEET 1 OF 18
DRAWING No. 1 REV 0

BID OPPORTUNITY No. 463-2014