

Room Finish Schedule

Number	Name	Area	North Wall	Finish	East Wall	Finish	South Wall	Finish	West Wall	Finish	Floor Finish	Base Finish	Ceiling Material	Ceiling Height	Ceiling Finish	Comments
100	VESTIBULE	84 SF	ALUM STOREFRONT	ANNOD	ALUM STOREFRONT	ANNOD	ALUM STOREFRONT	ANNOD	ALUM STOREFRONT	ANNOD	VSG	RWB	EXPOSED STRUCT	VARIES	PTD / STAIN	BOOT GRATE. STL STUD TO 600mm AFF ON WEST SIDE, ALUM STOREFRONT ABOVE.
101	FOYER	394 SF	GWB	PTD	ALUM STOREFRONT	ANNOD	GWB / ALUM ST	PTD / ANNOD	ALUM STOREFRONT	ANNOD	VSG	RWB	EXPOSED STRUCT	VARIES	PTD / STAIN	STL STUD TO 600 AFF ON WEST (PARTIAL) ALUMINUM STOREFRONT ABOVE.
102	OFFICE	155 SF	GWB	PTD	CMU	PTD	GWB	PTD	GWB	PTD	VSG	RWB	ACT	2750	-	BLIND WINDOW COVERINGS (SEE A702)
104	MULTI-PURPOSE ROOM	860 SF	GWB	PTD	CMU	PTD	GWB	PTD	GWB	PTD	VSG	RWB	EXPOSED STRUCT / GWB	3950 / 2700	PTD / STAIN	
105	KITCHEN	365 SF	GWB	PTD	CMU	PTD	GWB	PTD	GWB	PTD	VSG	COVE	ACT	2750	-	SCRUBBABLE CEILING TILE.
106	SKATE CHANGE	631 SF	ALUM ST / GWB	ANNOD / PTD	ALUM ST / CMU	ANNOD / PTD	GWB	PTD	ALUM ST / GWB	ANNOD / PTD	RSKF	RWB	EXPOSED STRUCT / GWB	VARIES	PTD / STAIN	VCT STRIP AT SOUTH END (SEE 2 & 4 / A901).
106A	SKATE FOYER	146 SF	ALUM ST / GWB	ANNOD / PTD	GWB	PTD	ALUM STOREFRONT	ANNOD	-	-	RSKF	RWB	GWB	2750	PTD	
107	VESTIBULE	80 SF	ALUM STOREFRONT	ANNOD	GWB	PTD	ALUM ST / BRICK VENEER	ANNOD	ALUM STOREFRONT	ANNOD	RSKF	RWB	EXPOSED STRUCT	VARIES	PTD	BOOT GRATE. BRICK COLOUR #2 AT SOUTH WALL VENEER.
108	SERVICE / ZAMBONI	514 SF	GWB	PTD	GWB	PTD	GWB	PTD	GWB	PTD	CONC	RWB	EXPOSED STRUCT	4812	PTD	CEILING TO U/S OPEN WEB STL JOIST STRUCTURE. SEAL EXPOSED CONCRETE FLOOR.
110	UTR	109 SF	GWB	PTD	GWB	PTD	GWB	PTD	GWB	PTD	RSKF	RWB	GWB	2750	PTD	
111	GYM	5376 SF	CMU / GWB	PTD	CMU / GWB	PTD	CMU / GWB	PTD	CMU / GWB	PTD	VCT	RWB	EXPOSED STRUCT	9300	PTD	CONCRETE BLOCK TO 3600 AFF, AR GWB FROM 3600 ABOVE.
111A	STOR	196 SF	CMU	PTD	GWB	PTD	GWB	PTD	GWB	PTD	VCT	RWB	EXPOSED STRUCT	4300	PTD	
111B	STOR	123 SF	GWB	PTD	GWB	PTD	CMU	PTD	GWB	PTD	VCT	RWB	EXPOSED STRUCT	4812	PTD	
113	WOMENS W/C	332 SF	GWB	PTD	GWB	PTD	GWB	PTD	GWB	PTD	VSG	COVE	GWB	2750	PTD	
113A	ELEC	80 SF	GWB	PTD	GWB	PTD	GWB	PTD	GWB	PTD	CONC	RWB	EXPOSED STRUCT	4300	PTD	SEAL EXPOSED CONCRETE FLOOR.
114	MENS W/C	208 SF	GWB	PTD	GWB	PTD	GWB	PTD	GWB	PTD	VSG	COVE	GWB	2750	PTD	
200	MECHANICAL MEZZANINE	748 SF	GWB	PTD	GWB	PTD	GWB	PTD	GWB	PTD	CONC	RWB	EXPOSED STRUCT	VARIES	PTD	SEAL EXPOSED CONCRETE FLOOR.
200A	STORAGE ROOM	74 SF	GWB	PTD	GWB	PTD	GWB	PTD	GWB	PTD	CONC	RWB	EXPOSED STRUCT	VARIES	PTD	SEAL EXPOSED CONCRETE FLOOR.
COR01	CORRIDOR	394 SF	-	-	GWB	PTD	-	-	ALUM STOREFRONT	ANNOD	VSG	RWB	EXPOSED STRUCT	3950	PTD / STAIN	STL STUD TO 600mm AFF ON WEST WALL, ALUM STOREFRONT ABOVE.
COR02	CORRIDOR	85 SF	ALUM STOREFRONT / GWB	ANNOD / PTD	GWB	PTD	-	-	-	-	VSG	COVE	GWB	2750	PTD	TACTILE WARNING (SEE FLOORING PLAN).

GENERAL COMMENTS:
 1. NO COVE BASE ON STOREFRONT GLAZING.
 2. IN ALL PUBLICALLY ACCESSIBLE AREAS; ALL EXPOSED MECHANICAL DUCTWORK AND ELECTRICAL CONDUIT TO BE PAINTED TO MATCH CEILING COLOUR.

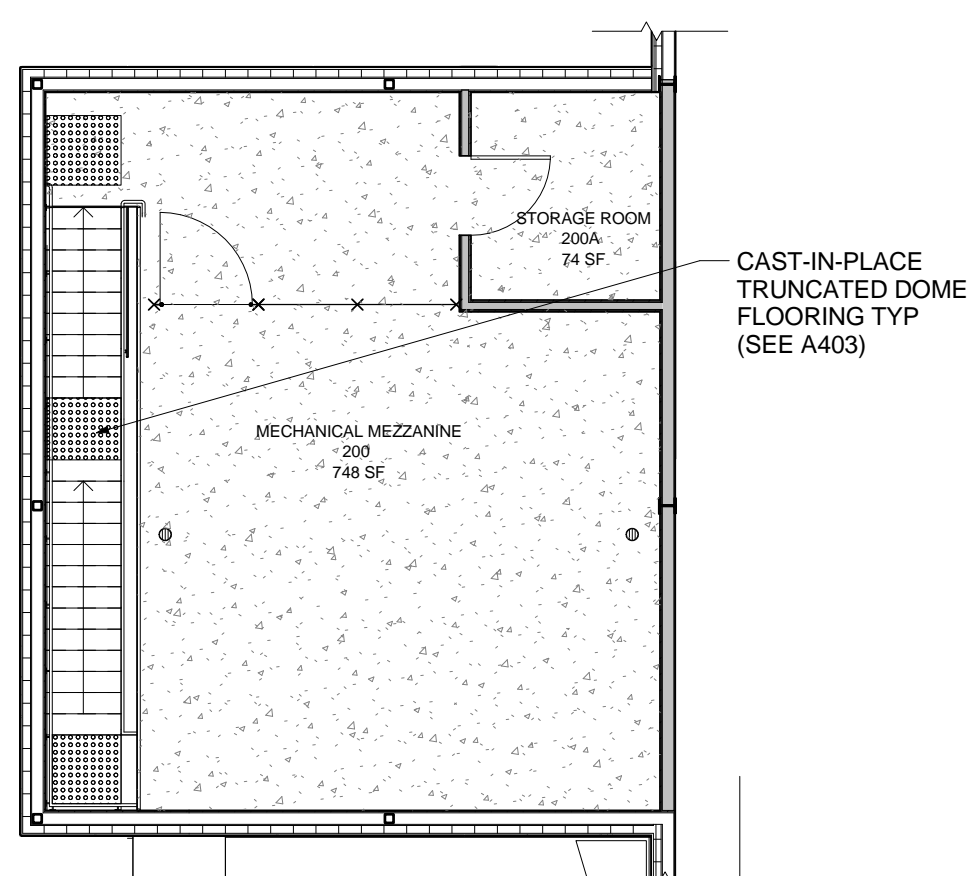

1 FLOORING PLAN - MEZZANINE
1:100

FLOORING LEGEND:

- VINYL SHEET - PRIMARY
- VINYL SHEET - CONTRASTING
- VINYL COMPOSITE TILE - PRIMARY
- VINYL COMPOSITE TILE - CONTRASTING
- SKATE FLOORING - PRIMARY
- SKATE FLOORING - CONTRASTING
- TACTILE WARNING
- EXPOSED CONCRETE SEALED
- RUBBER WALL BASE
- VINYL COVE WALL BASE

KEYNOTE LEGEND:

- 1 305mm W, 6mm H - ALUMINUM THRESHOLD
- 2 152mm W, 6mm H - ALUMINUM THRESHOLD
- 3 102mm W, 6mm H - ALUMINUM THRESHOLD
- 4 ALUM DIVIDER STRIP BETWEEN VINYL COMPOSITE TILE AND VINYL SHEET
- 5 ALUM DIVIDER STRIP BETWEEN SKATE FLOORING AND VINYL COMPOSITE TILE

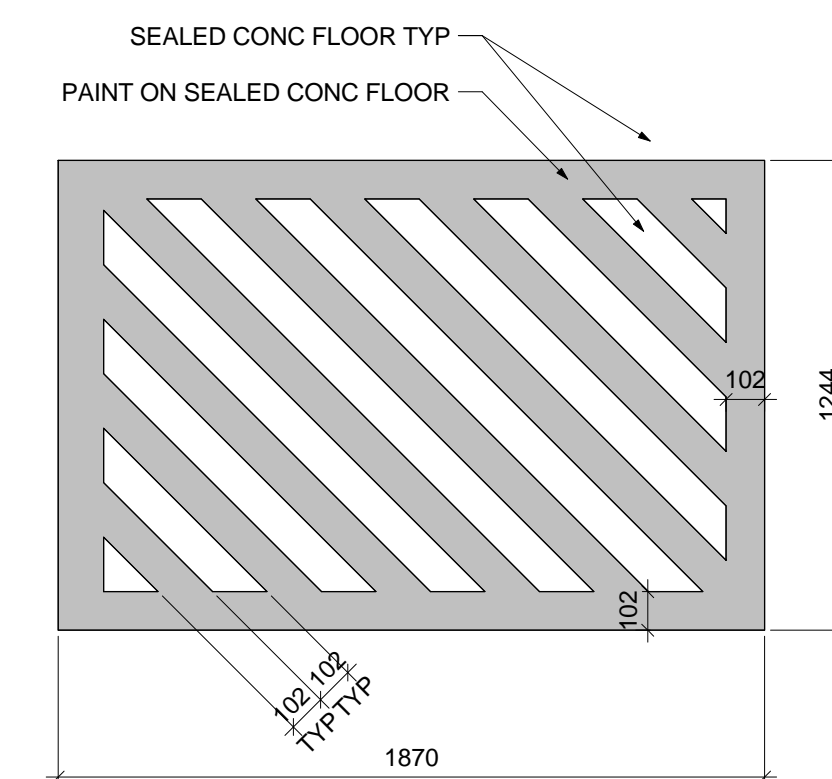

3 FLOOR PAINTING PLAN DETAIL
1:20

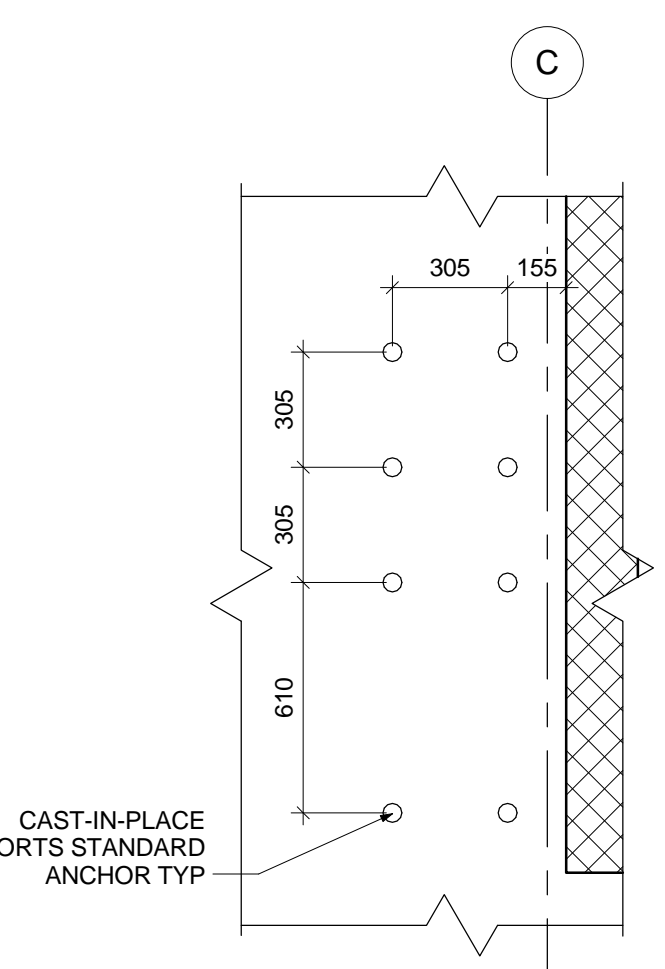

5 CAST-IN-PLACE SPORTS ANCHOR STORAGE
1:20

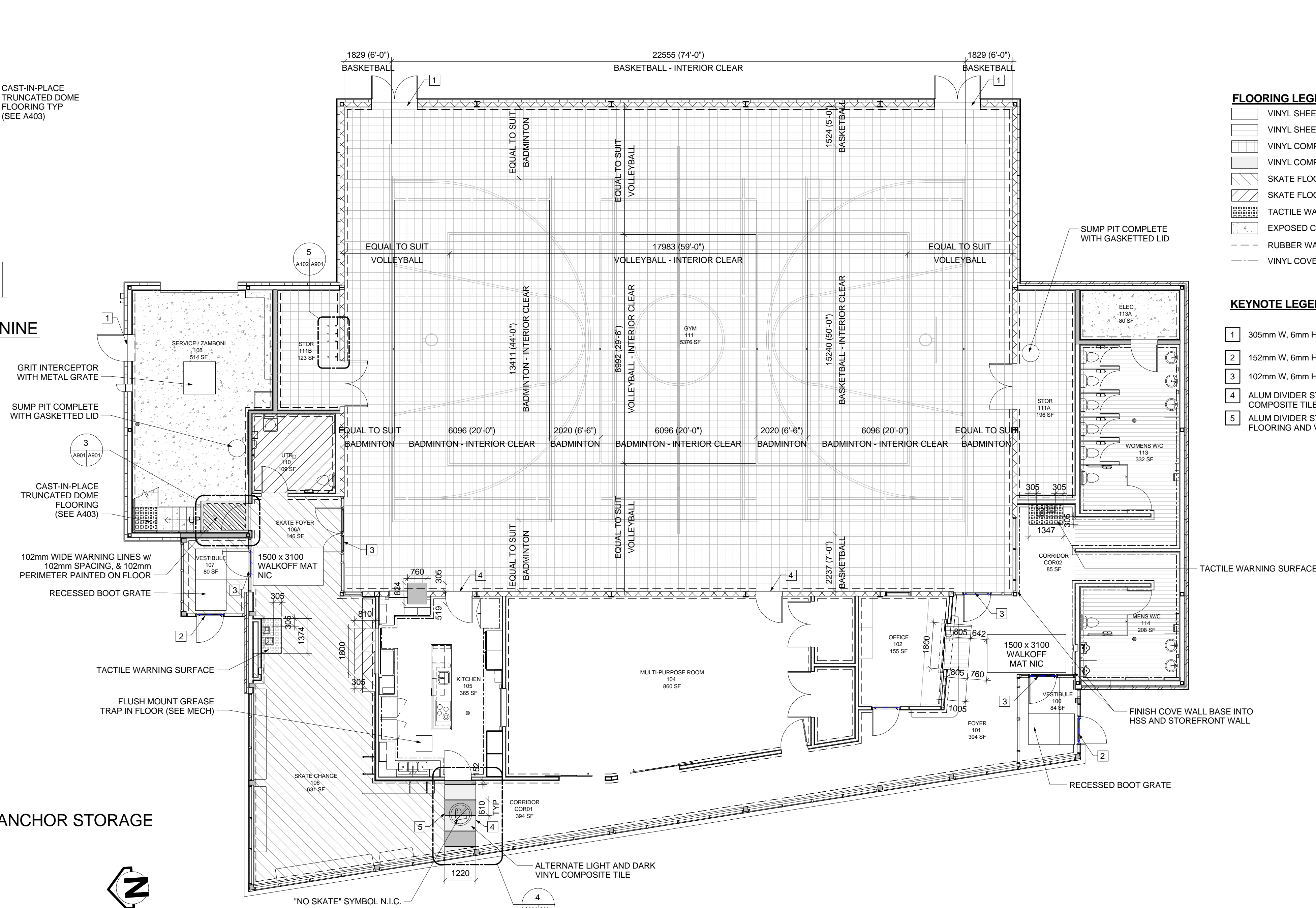

2 FLOORING PLAN - MAIN FLOOR
1:100

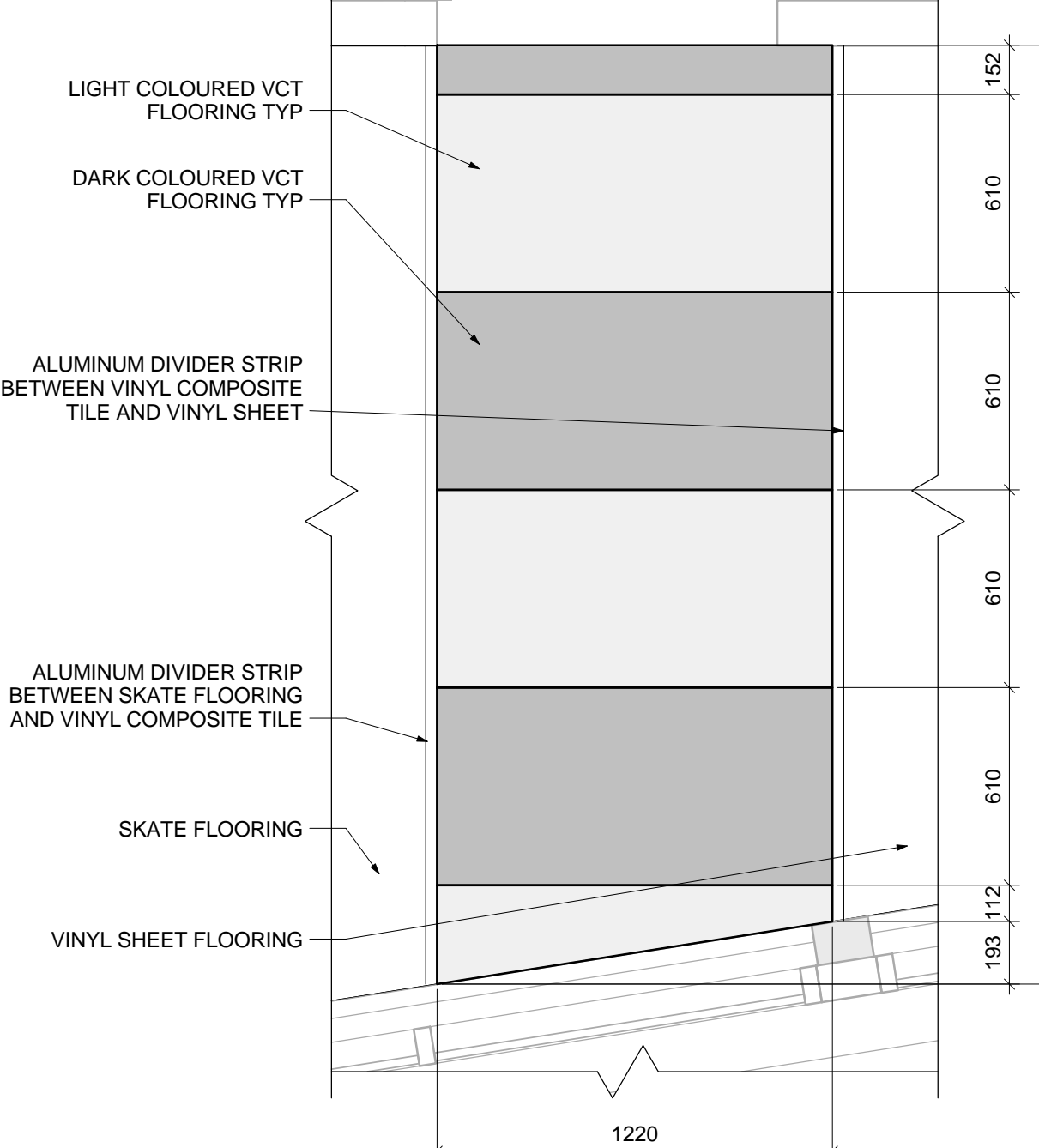

4 FLOOR TRANSITION TILE PATTERN
1:20

bridomancollaborative
www.bridomancollaborative.ca

878 MAIN STREET WINNIPEG, MB R3B 1E4
204 488 3857 tel. 204 488 0216 fax.

Winnipeg
THE CITY OF WINNIPEG PLANNING, PROPERTY AND DEVELOPMENT DEPARTMENT
MUNICIPAL ACCOMMODATIONS DIVISION
4TH FLOOR - 185 KING STREET
R3B 1J1

Project: EAST ELMWOOD COMMUNITY CENTRE
490 KEENLEYSIDE, WINNIPEG, MB

Project Number: 2013-041
S&P Opportunity Number: 748-2013

Drawing Title: ROOM SCHEDULE

#	Issue/Revision	Date
1	ISSUED FOR TENDER	2013-10-09

Design By: [Blank]
Date: [Blank]

Design Check: [Blank]
Date: [Blank]

Draw By: [Blank]
Date: [Blank]

DWG Check: [Blank]
Date: [Blank]

Sheet No: A901

This drawing is property of the Consultant and cannot be reproduced or used without the consent of the Consultant. The user is responsible for checking and verifying all levels and dimensions and shall report all discrepancies to the Consultant and obtain clarification prior to commencing work.