

1 PLAN DETAIL - TYPICAL PANEL JOINT
1:5

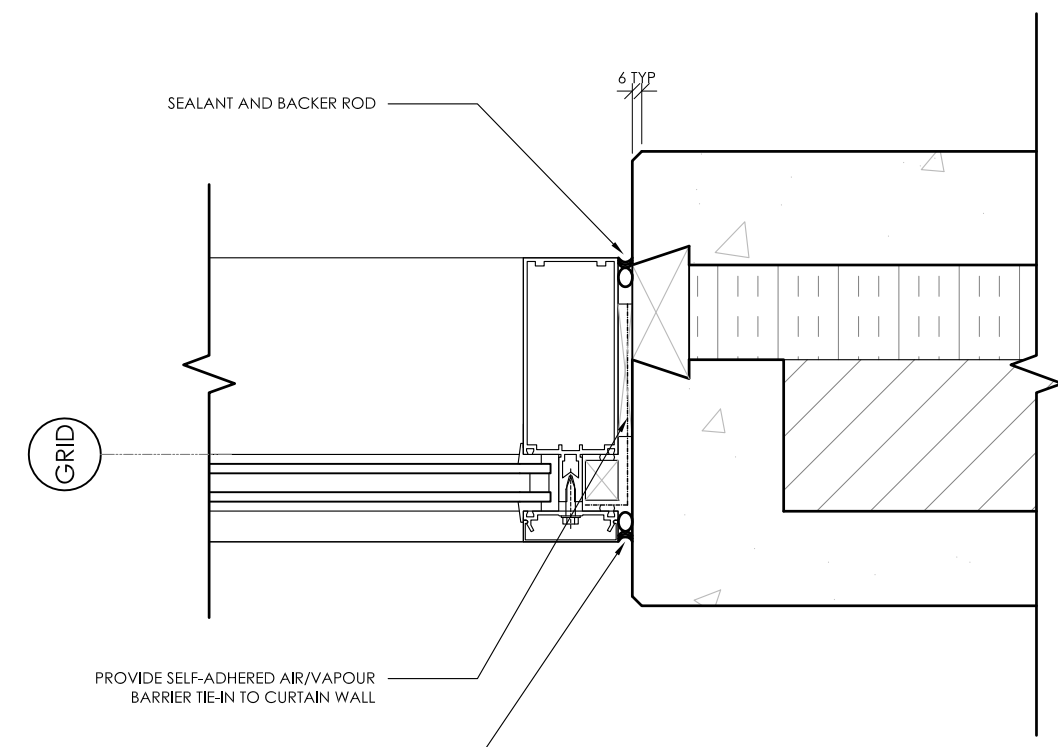

2 PLAN DETAIL - TYPICAL CURTAIN WALL JAMB
1:5

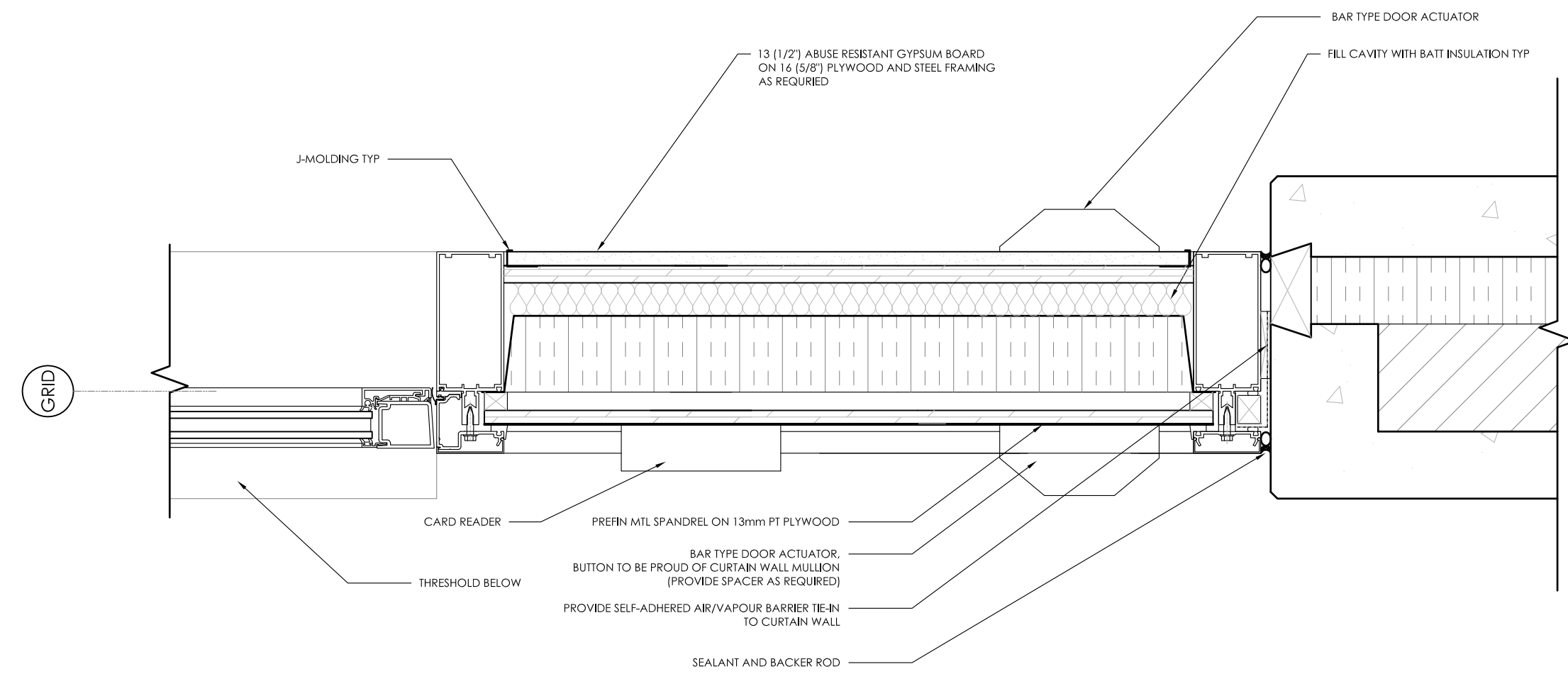

3 PLAN DETAIL - CURTAIN WALL JAMB AT ENTRANCE
1:5

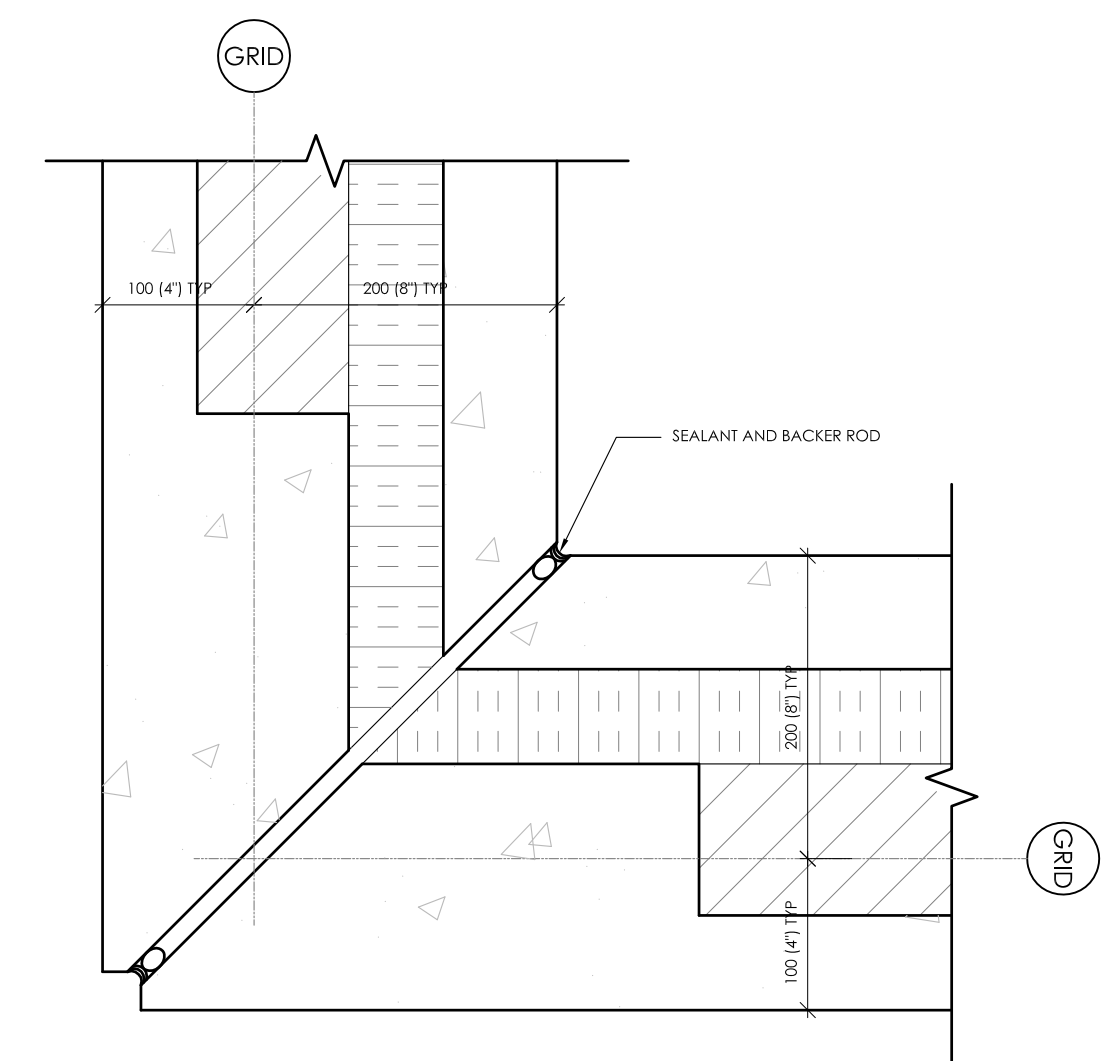

4 PLAN DETAIL - TYPICAL MITRED CORNER
1:5

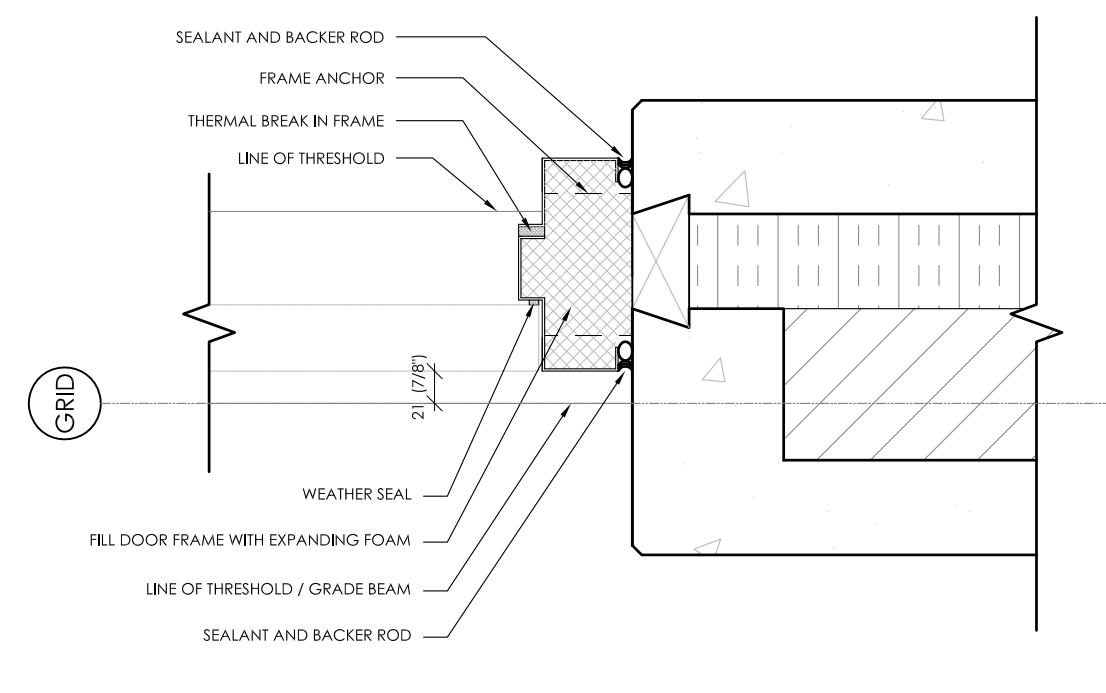

5 MECHANICAL ROOM DOOR JAMB
1:5

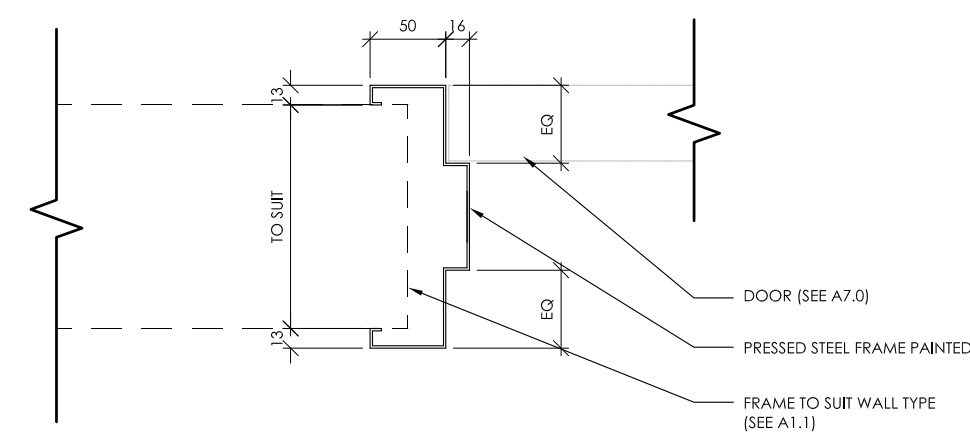

6 TYPICAL INTERIOR STEEL DOOR JAMB
1:5

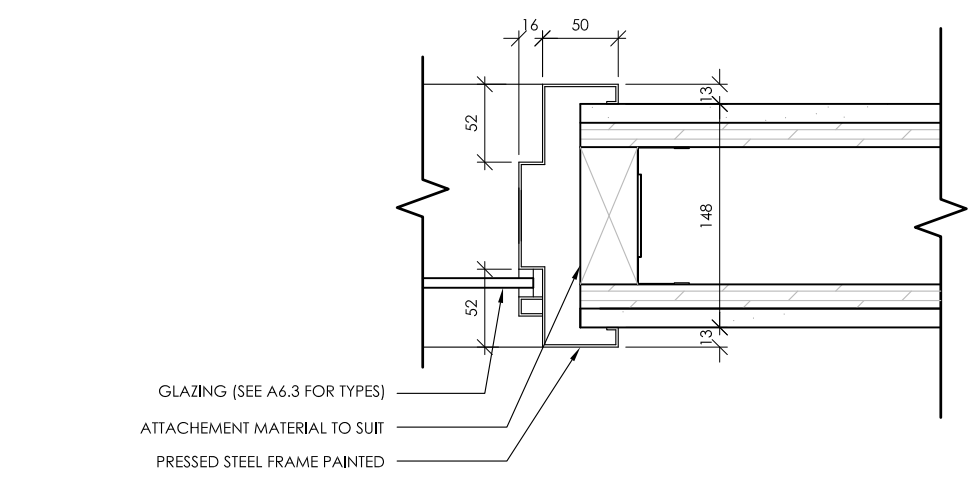

7 TYPICAL INTERIOR STEEL FRAMING JAMB
1:5

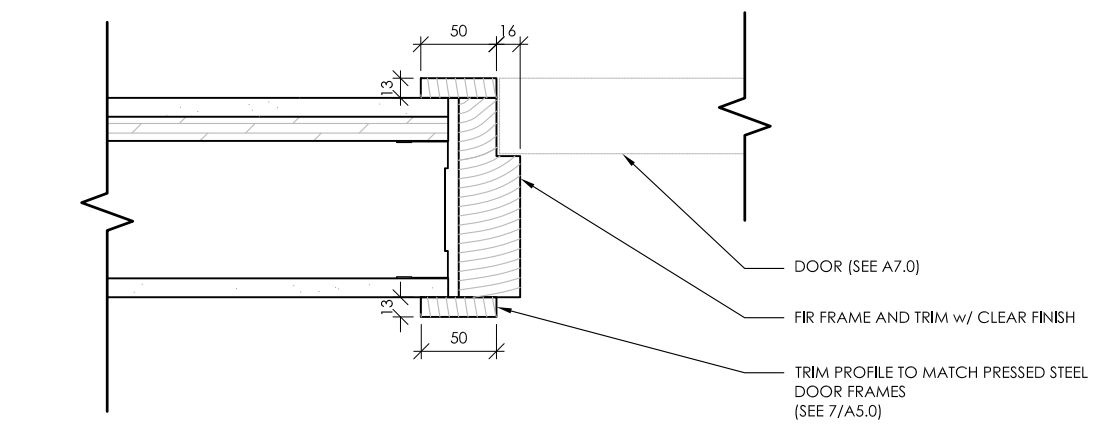

8 TYPICAL INTERIOR WOOD DOOR JAMB
1:5

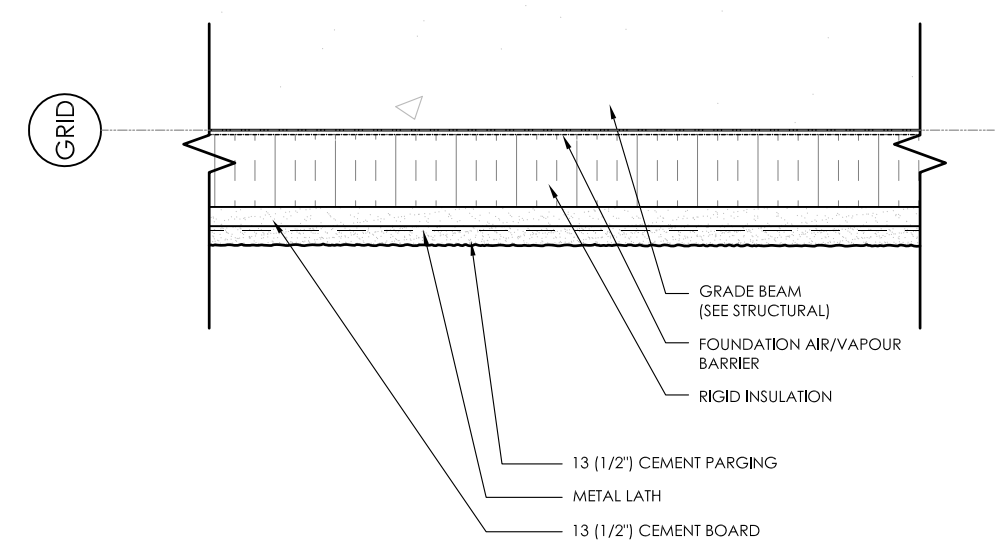

13 PLAN DETAIL - GRADE BEAM
1:5

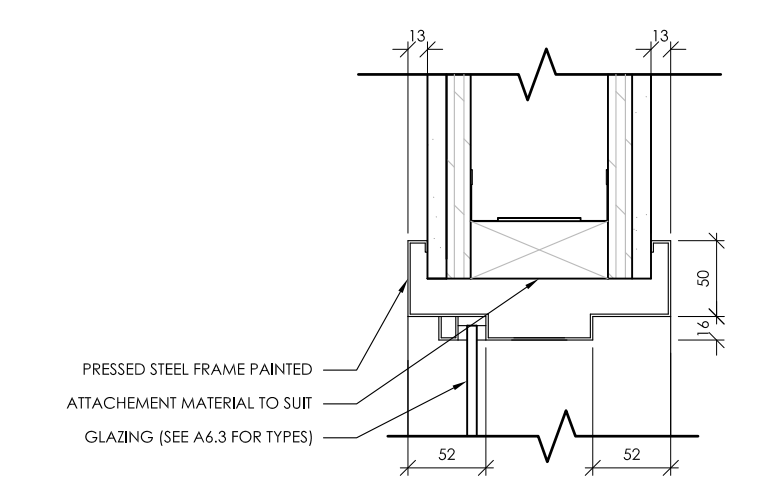

10 TYPICAL INTERIOR STEEL FRAMING HEAD
1:5

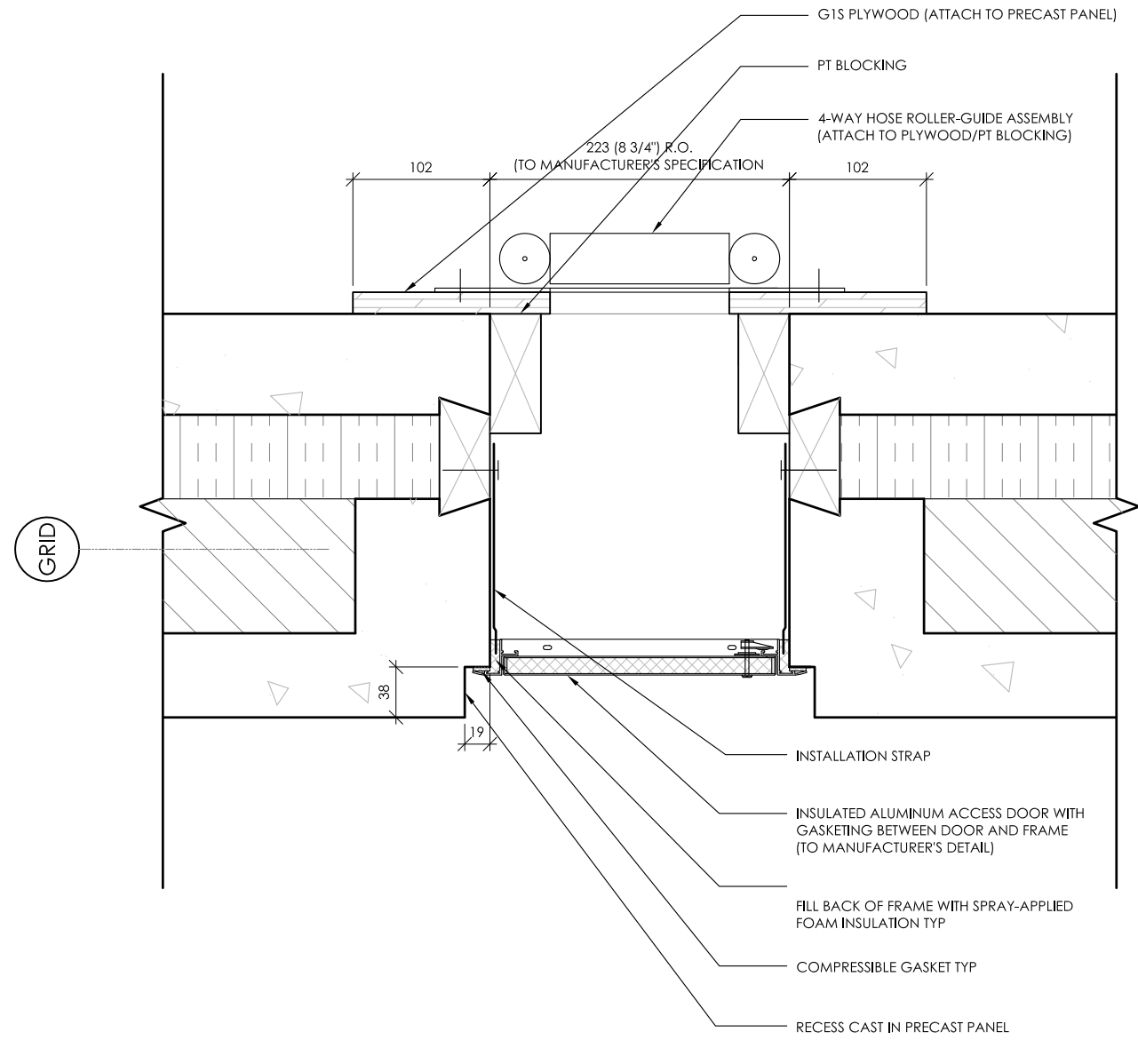

12 PLAN DETAIL - HOSE ACCESS DOOR
1:5

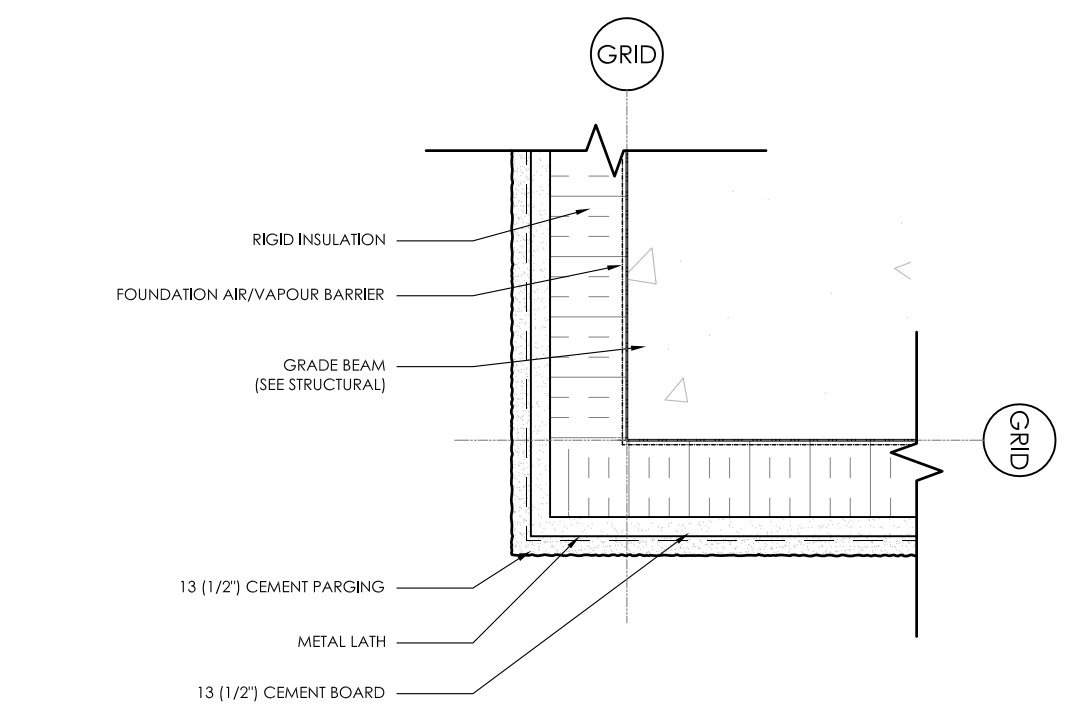

14 PLAN DETAIL - GRADE BEAM AT OUTSIDE CORNER
1:5

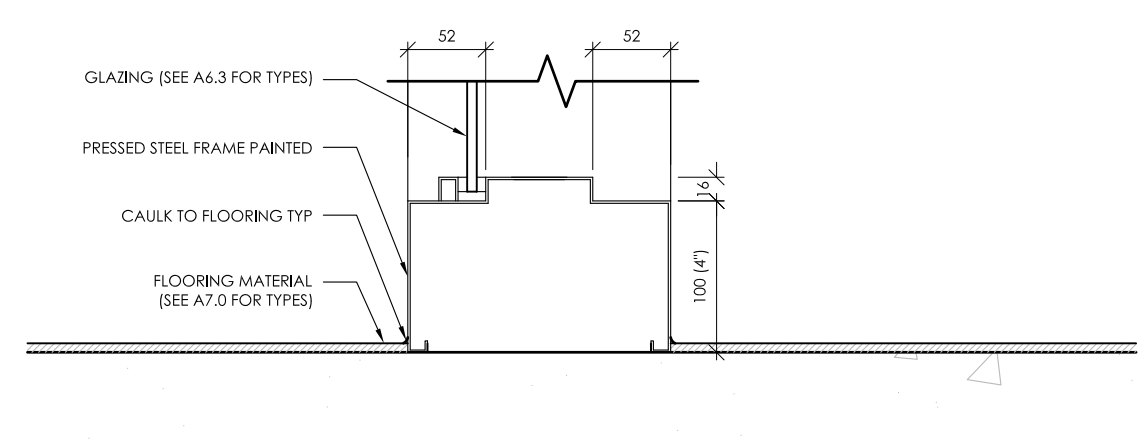

11 TYPICAL INTERIOR STEEL FRAMING SILL
1:5

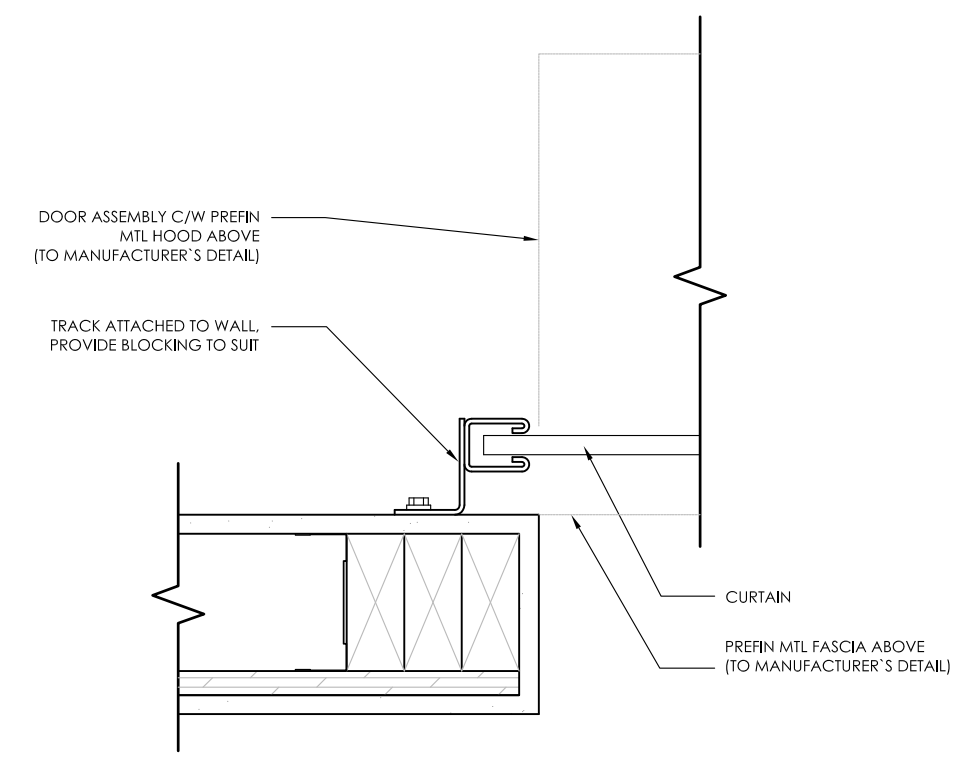

9 OVERHEAD DOOR JAMB
1:5

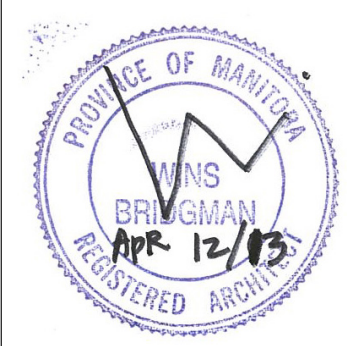

Project:
MAYFAIR
RECREATION
CENTRE

Project Number: 2011-112
Bid Opportunity Number: 556-2012

Drawing Title:
PLAN AND MISC
DETAILS

#	Issue/Revision	Date
1	66% REVIEW	AUG 16 2012
2	66% REISSUE REVIEW	NOV 26 2012
3	99% REVIEW	MAR 6 2013
4	ISSUED FOR TENDER	APR 12 2013

Sheet No: **A5.0**

This drawing is property of the Architect and copyright is reproduced for use without the consent of the Architect. The contractor is responsible for checking and verifying all notes and dimensions and providing a report of discrepancies to the Architect and secure clarification prior to commencing work.