

1 PLAN DETAIL - AMENITY SPACE  
 L-3 1:200

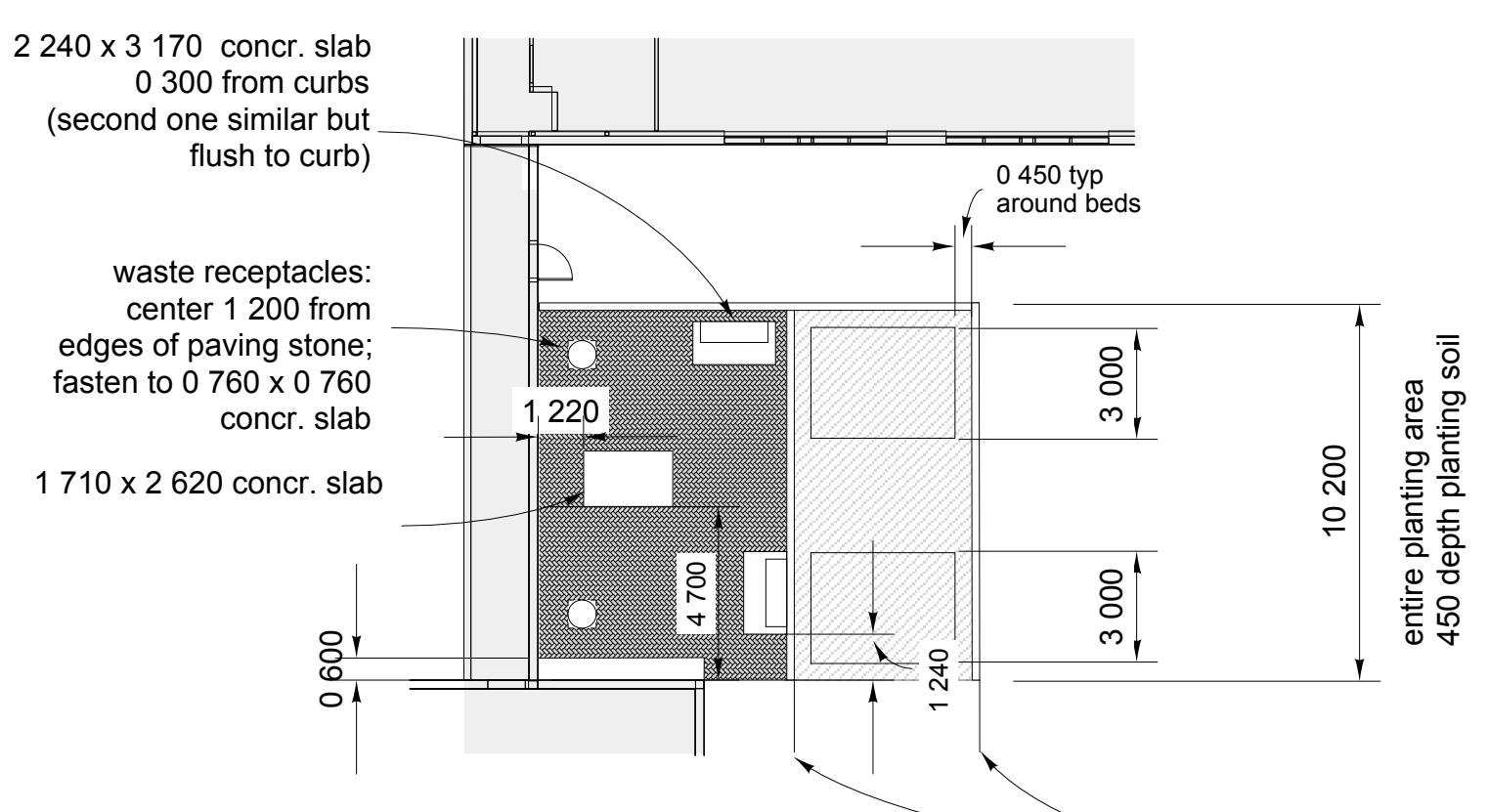

2 PLAN DETAIL - AMENITY SPACE LAYOUT  
 L-3 1:200

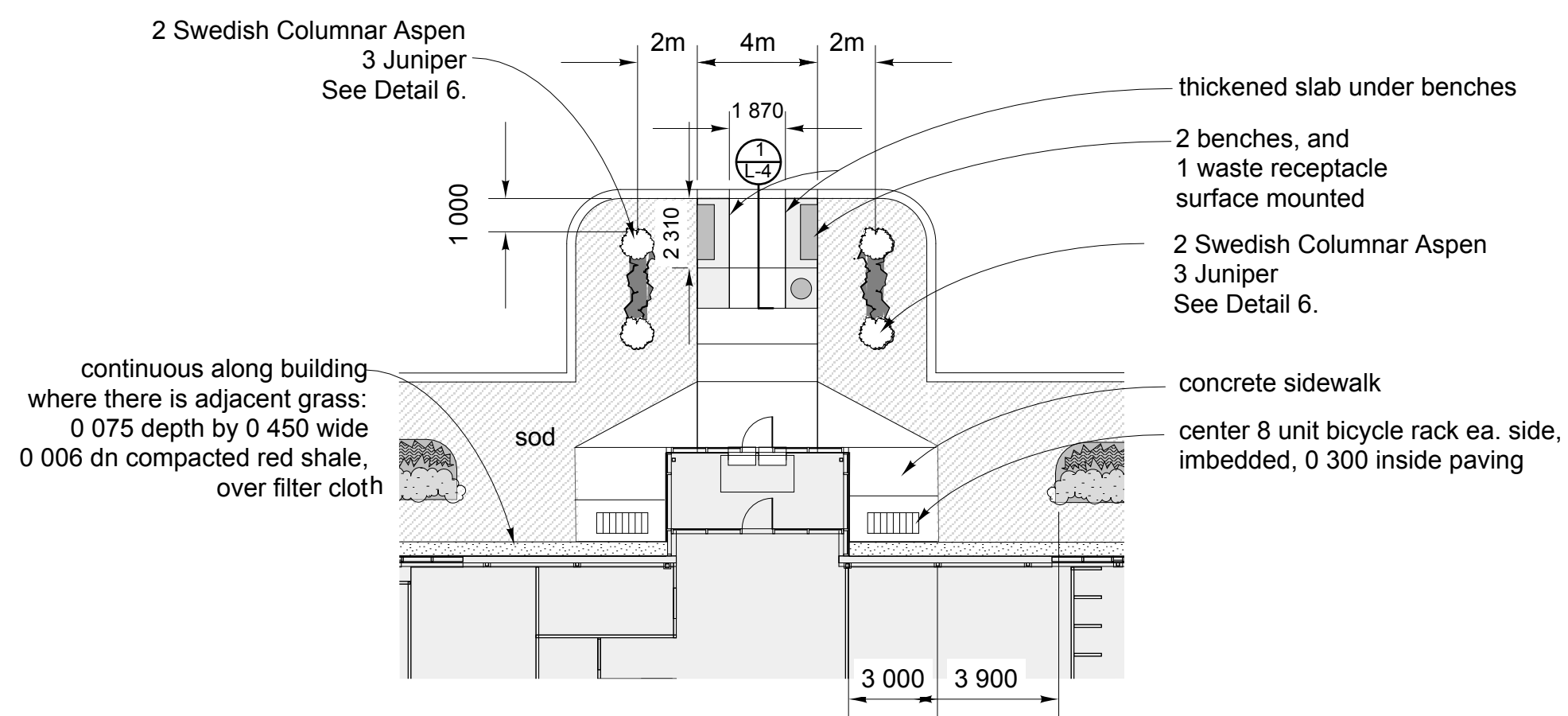

5 PLAN DETAIL  
 L-3 1:200

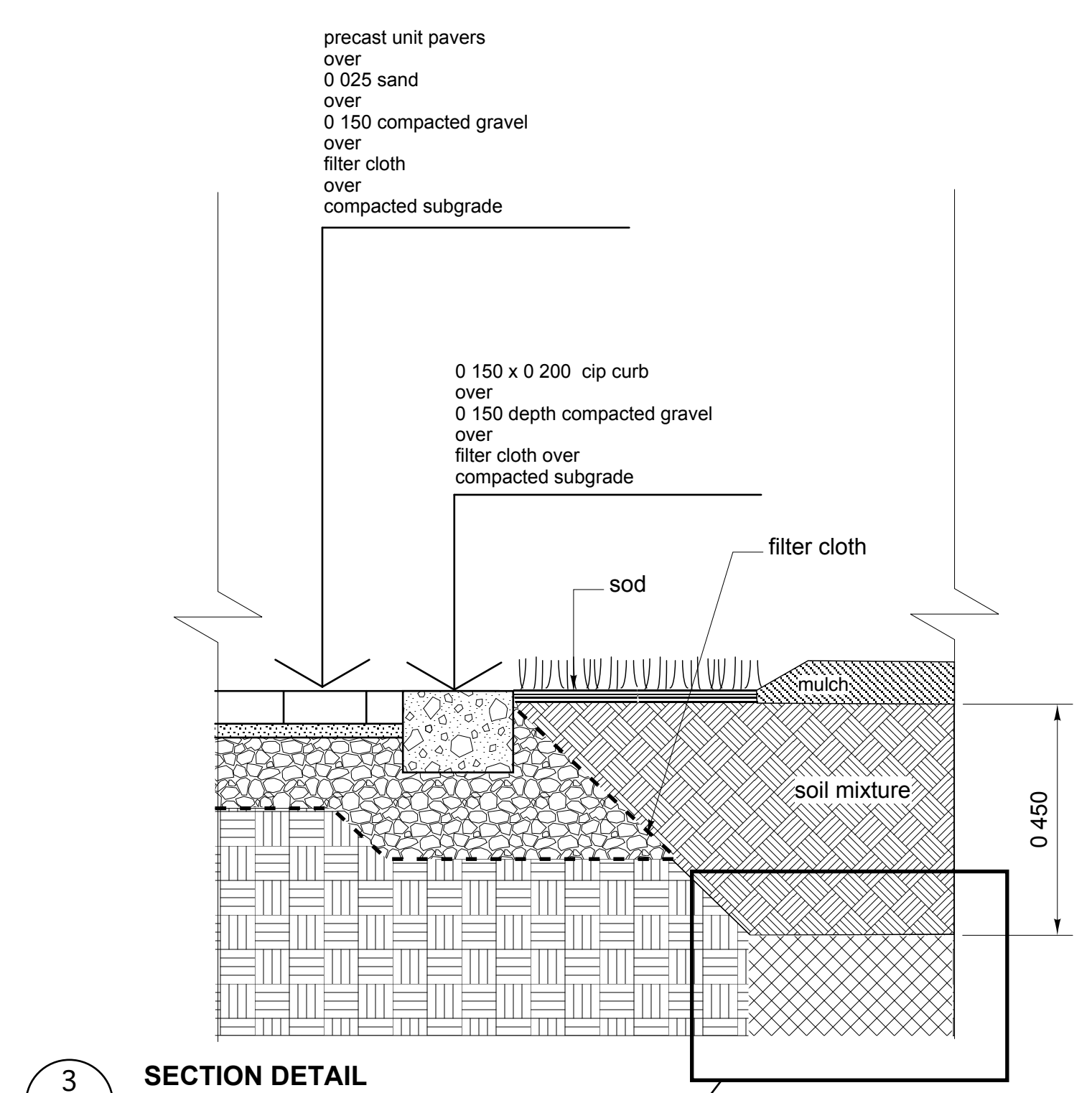

3 SECTION DETAIL  
 L-3 1:10

NOTE:  
 SUBGRADE BENEATH PLANTING  
 BED MUST BE COMPACTED CLAY FILL  
 TO 1 000 BELOW FINISHED GRADE.  
 EXCAVATE GRAVEL AS NECESSARY.

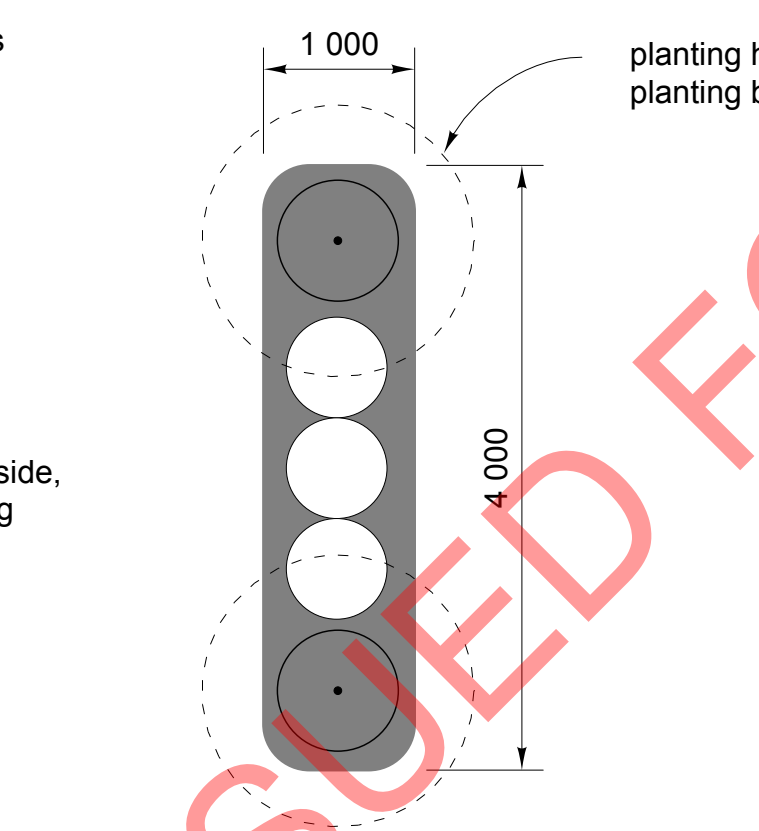

6 PLAN DETAIL - PLANTING BED  
 L-3 1:50

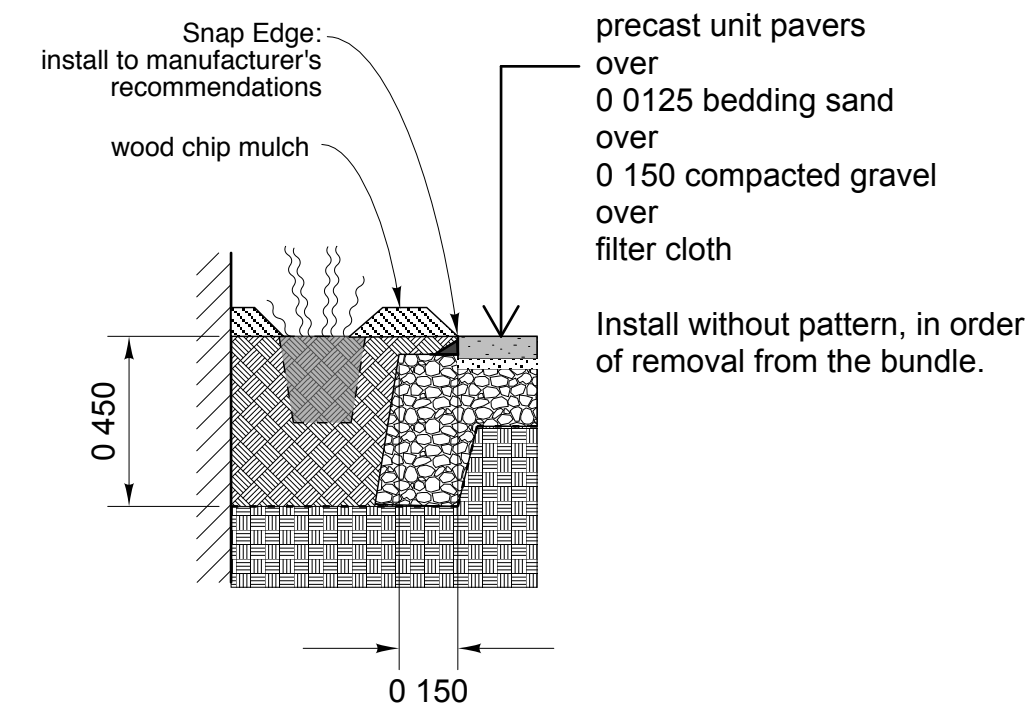

4 SECTION DETAIL  
 L-3 1:20

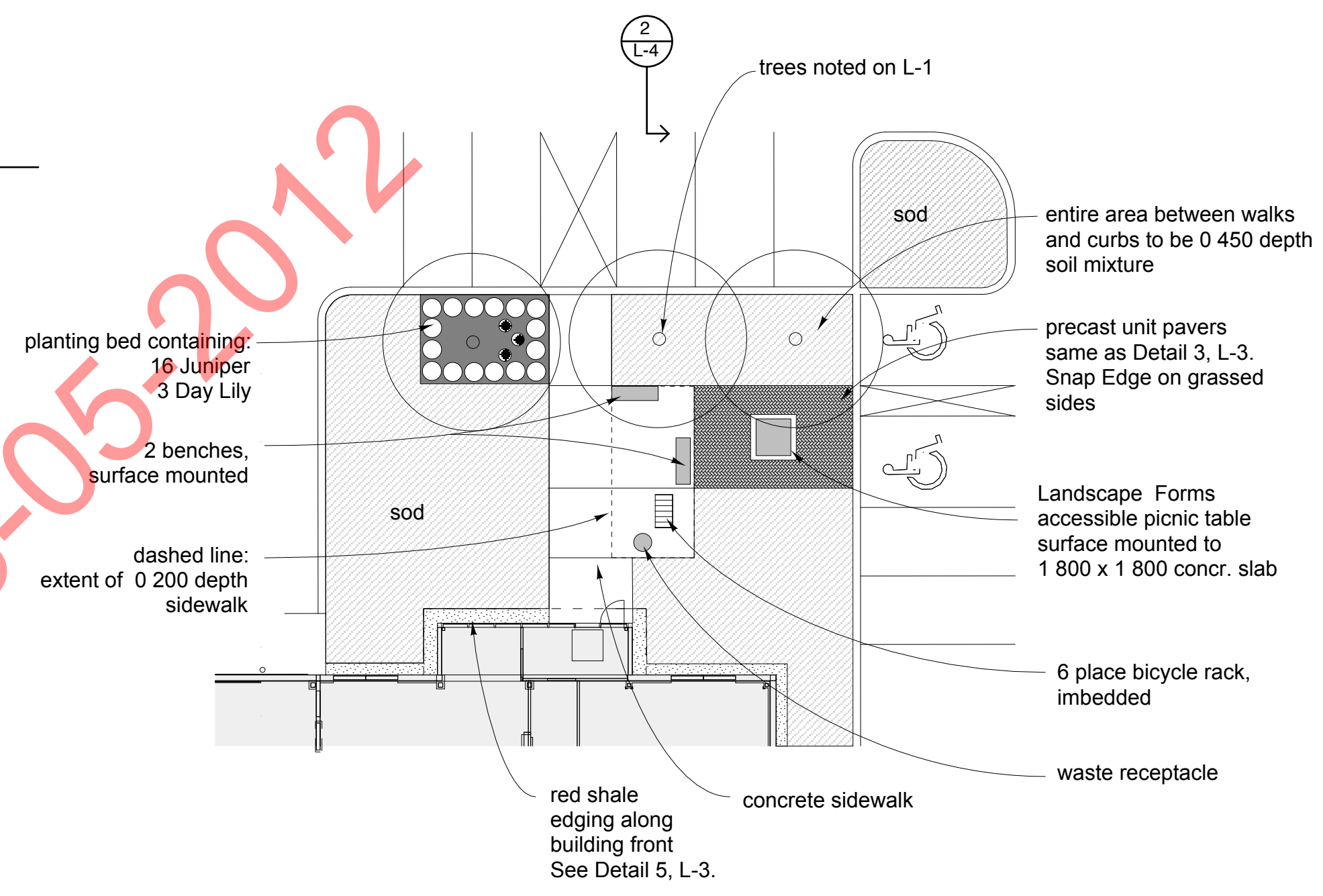

7 PLAN DETAIL - AMENITY SPACE  
 L-3 1:200

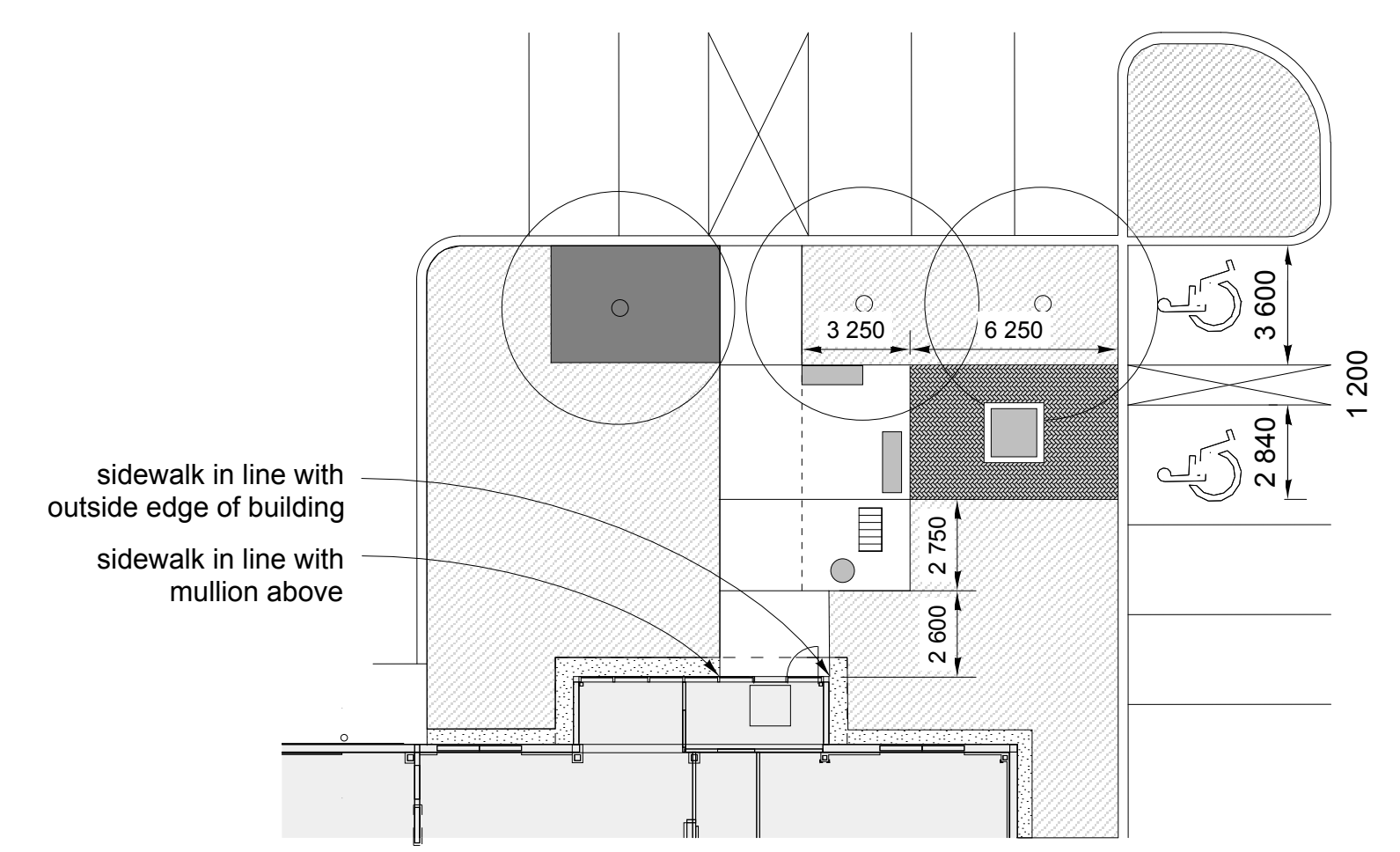

8 PLAN DETAIL - AMENITY SPACE LAYOUT  
 L-3 1:200

The Contractor shall verify all dimensions, datums and levels prior to commencement of work. All errors and omissions to be reported to the Landscape Architect before proceeding.

This drawing must not be scaled.

This drawing is the property of the Landscape Architect; the copyright in same being reserved to him. It is not to be reproduced without his permission.

Any unauthorized alteration of the electronic data which constitute this document will void all responsibility for the altered document by the Architect.

This drawing is not to be used for building purposes until countersigned by:  
 Cynthia Coilmeyer  
 Seal



RECORD OF DRAWINGS			RECORD OF DRAWINGS		
REF	DATE	DESCRIPTION	REF	DATE	DESCRIPTION
1	14.05.2012	ISSUED FOR 99% REVIEW			
2					
3					

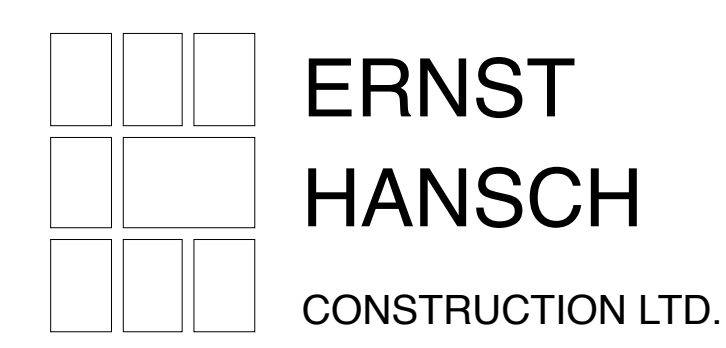

3 TERRACON PLACE  
 WINNIPEG, CANADA R2J 4B3  
 TEL. (204) 233 7881  
 FAX (204) 233 4733  
 general@ehansch.com  
 www.ehansch.com

CLIENT: CITY OF WINNIPEG  
 PROJECT NUMBER:  
 DRAWN BY: C.C.  
 DATE: MAY 7, 2012  
 SCALE: AS SHOWN

PROJECT TITLE:  
**WINNIPEG PUBLIC WORKS  
 EAST YARD COMPLEX**  
 960 THOMAS AVENUE, WINNIPEG, MANITOBA  
 SHEET TITLE:  
**LANDSCAPE DETAILS**

**CLA**  
 CYNTHIA COILMEYER  
 LANDSCAPE ARCHITECT  
 359 McDERMOT AVE  
 Winnipeg MB R3A 0A6  
 (204) 943-1394 FAX 942-4426  
 cynthia@cohlarch.ca

SHEET NUMBER:

**L-3**