

Drawing Title:

Drawing No:

TACHE STYLE WHEELCHAIR METAL FRAME PICNIC TABLE

SCD-122A

MATERIALS

WOOD SLATS:

- VERTICAL GRAIN CLEAR SITCA SPRUCE OR CLEAR CEDAR
- FINISH - SIKKENS CETOL No. 078 NATURAL or PAINTED FINISH: GREEN, WALNUT, CEDAF OR GREY (AS SPECIFIED)

METAL LEGS:

GALVANIZED

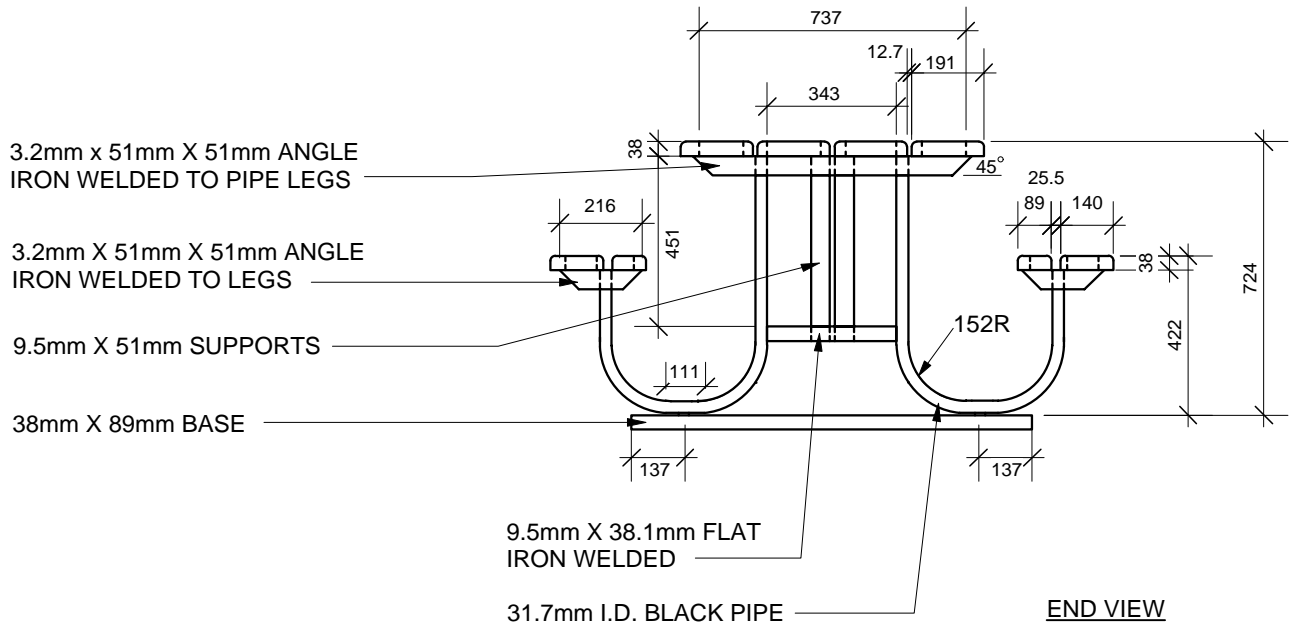
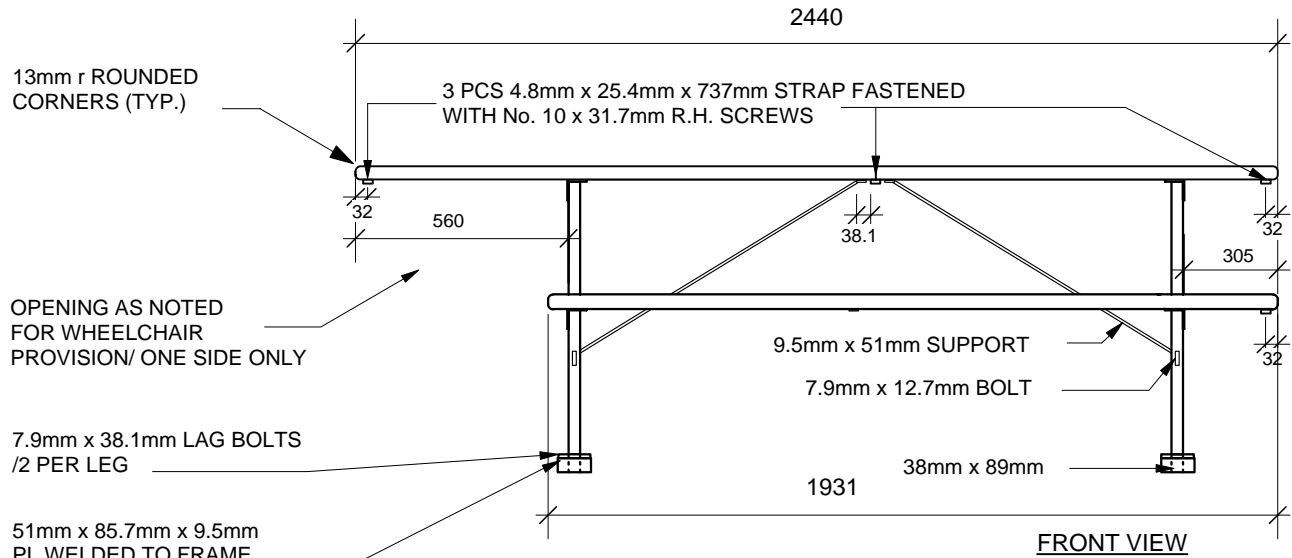

NOTE:

ALL WOOD TO BE FASTENED TO ANGLE IRONS WITH 7.9mm X 38.1mm LAG BOLTS.

DIMENSIONS SHOWN ARE IN MILLIMETRES UNLESS OTHERWISE SPECIFIED

REVISION: 1
 DATE: January 12, 2012
 SCALE: N.T.S.
 DRAWN BY: SP

The City of Winnipeg
 Planning, Property and Development Department
 Parks, Waterways & Community Initiatives Division
 Unit 15 - 30 Fort Street, Winnipeg, MB, R3C 4X5

