



**van der Zalm + associates inc.**  
Landscape Architecture • Urban Design • Parks & Recreation  
Suite 2200 1177 W. Hastings St. P 604.882.0024  
Vancouver, British Columbia F 604.882.0042  
V6E 2K3 info@www.vdzr.ca

The Warehouse Design Studio  
8938 192 Street P 604.882.0024  
Surrey, British Columbia F 604.882.0042  
V4N 3V8 info@www.vdzr.ca

NOTES

LEGEND

- BW BOTTOM OF WALL
  - TW TOP OF WALL
  - BB BOTTOM OF BANK
  - TB TOP OF BANK
  - BX BOTTOM OF BOX
  - TX TOP OF BOX
  - ES EDGE OF SLAB
  - TS TOP OF SLAB
  - RIM RIM OF DRAIN
  - TL TOP OF LEDGE
  - BL BOTTOM OF LEDGE
  - TC TOP OF CURB
  - BC BOTTOM OF CURB
  - INV INVERT
  - LB LAWN BASIN
  - TT TOP OF TRANSITION
  - BT BOTTOM OF TRANSITION
  - TR TOP OF RAMP
  - BR BOTTOM OF RAMP
  - TI TIE IN LEVEL
- \* RAMP = A BANK WITHOUT A RADIUS AT BOTTOM

100mm PVC PIPE

150mm PVC PIPE

▲ = direction of water flow

⊗ = Watts series FD-300 floor drain

© Copyright reserved. This drawing and design is the property of van der Zalm + associates inc., and may not be reproduced or used for other projects without permission.

No.	Description	Date
0.	Issue for Tender	Mar. 03/06

REVISIONS-DRAWING ISSUE

CONTRACTOR SHALL CHECK ALL DIMENSIONS ON THE WORK AND REPORT ANY DISCREPANCY TO THE CONTRACT ADMINISTRATOR BEFORE PROCEEDING. ALL DRAWINGS AND SPECIFICATIONS ARE THE EXCLUSIVE PROPERTY OF THE CONTRACT ADMINISTRATOR AND MUST BE RETURNED AT THE COMPLETION OF THE WORK.

PROJECT:

**Komenda Memorial Park**

LOCATION:

**Winnipeg, Man.**

DRAWN

ML

CHECKED

MV

APPROVED

MV

CAD FILE  
LAYOUT PLAN

SCALE

1 : 150

DATE

Sept. 11/05

**DRAINAGE ONLY**

DRAWING TITLE

PROJECT NO.  
PR2005-37

DRAWING NO.  
**SK - 6**

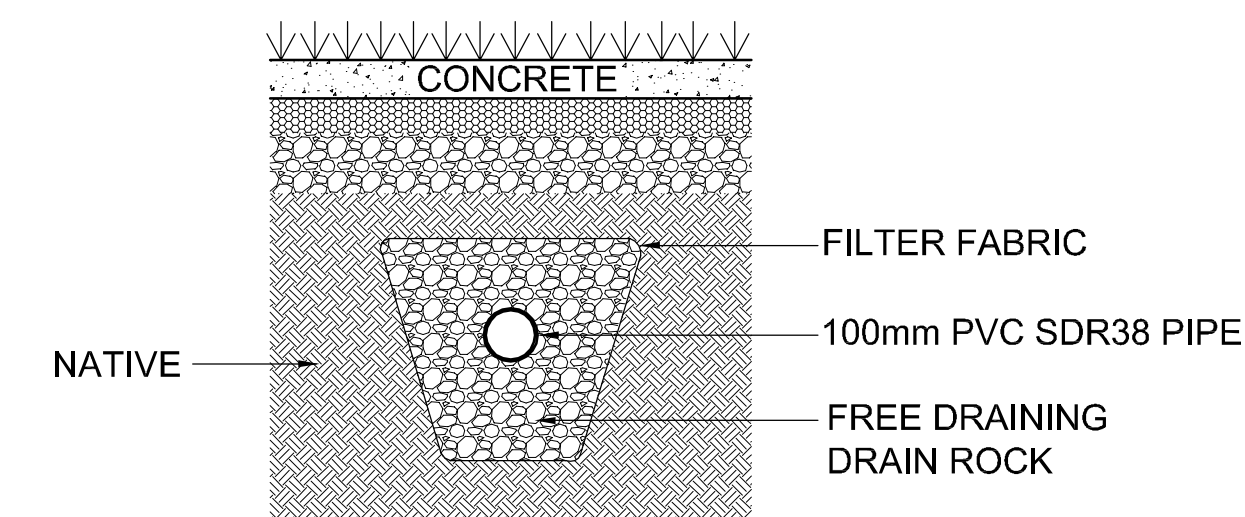
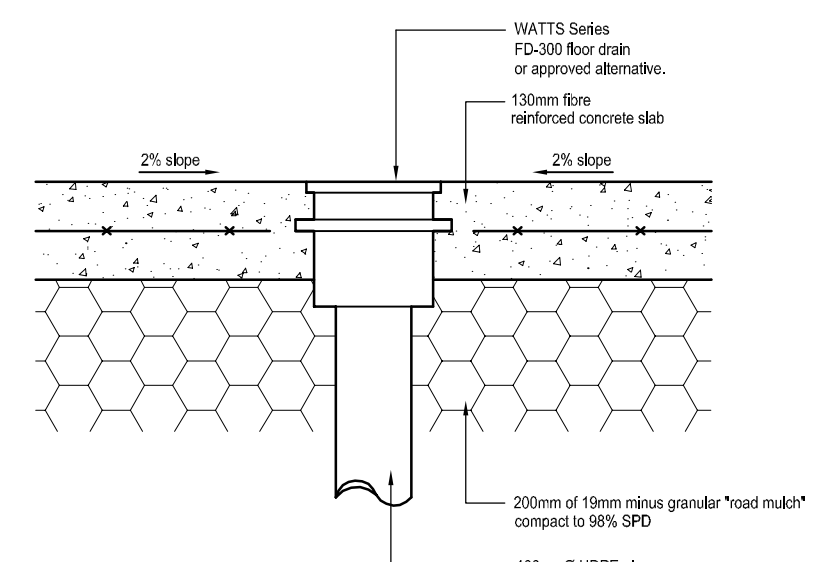
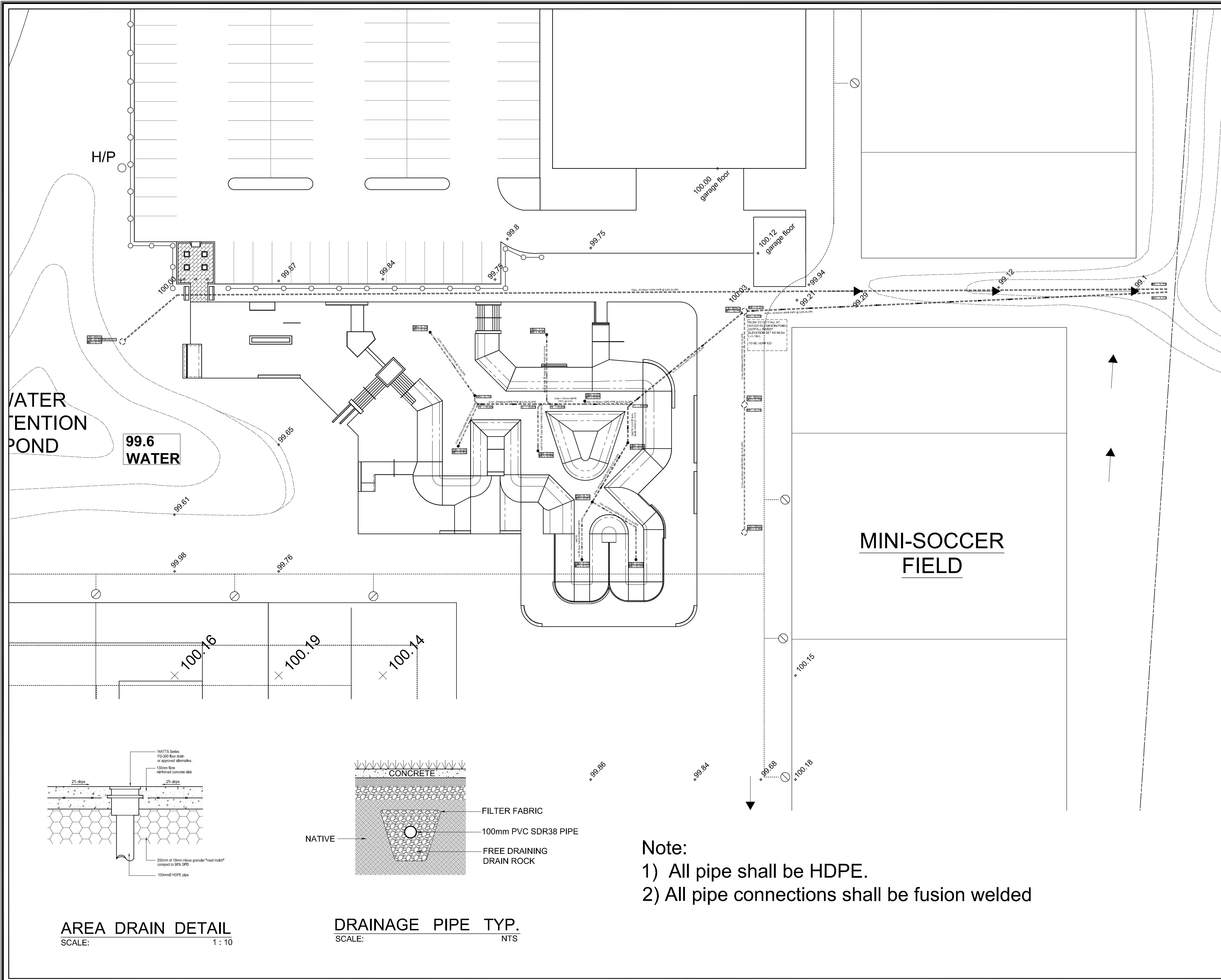

**Note:**  
1) All pipe shall be HDPE.  
2) All pipe connections shall be fusion welded