

**D**

Drawing Title:

Drawing No:

**WHEEL CHAIR METAL FRAME PICNIC TABLE**

SCD 130a

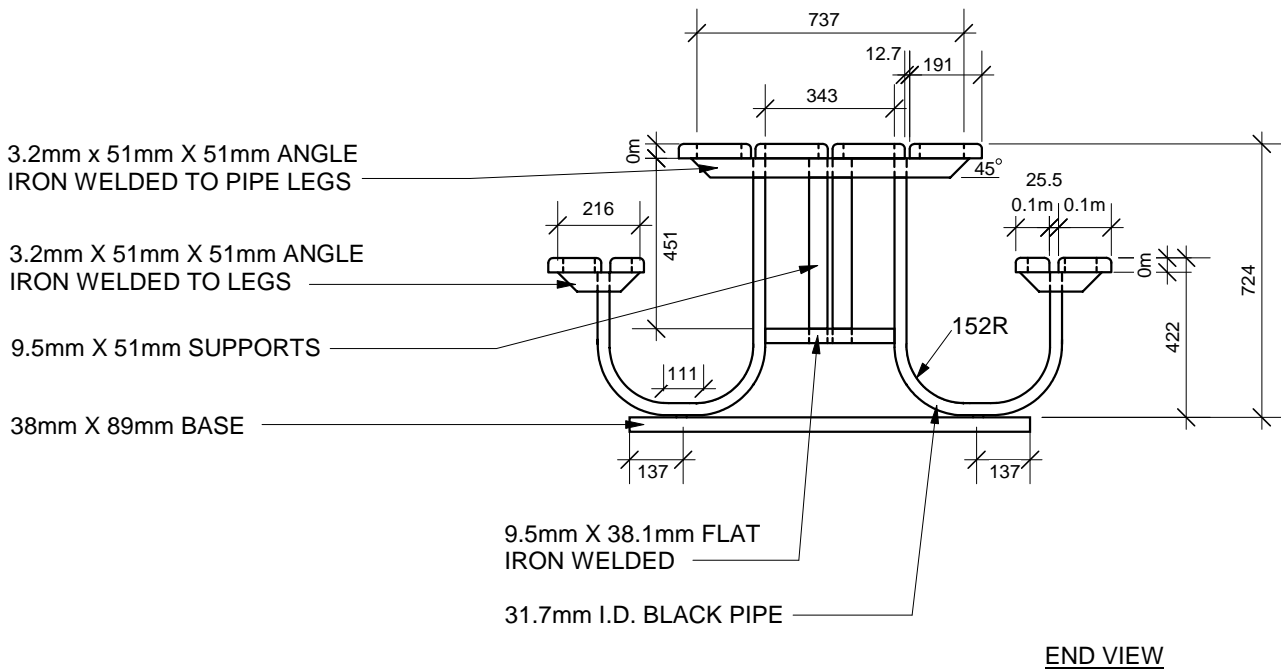
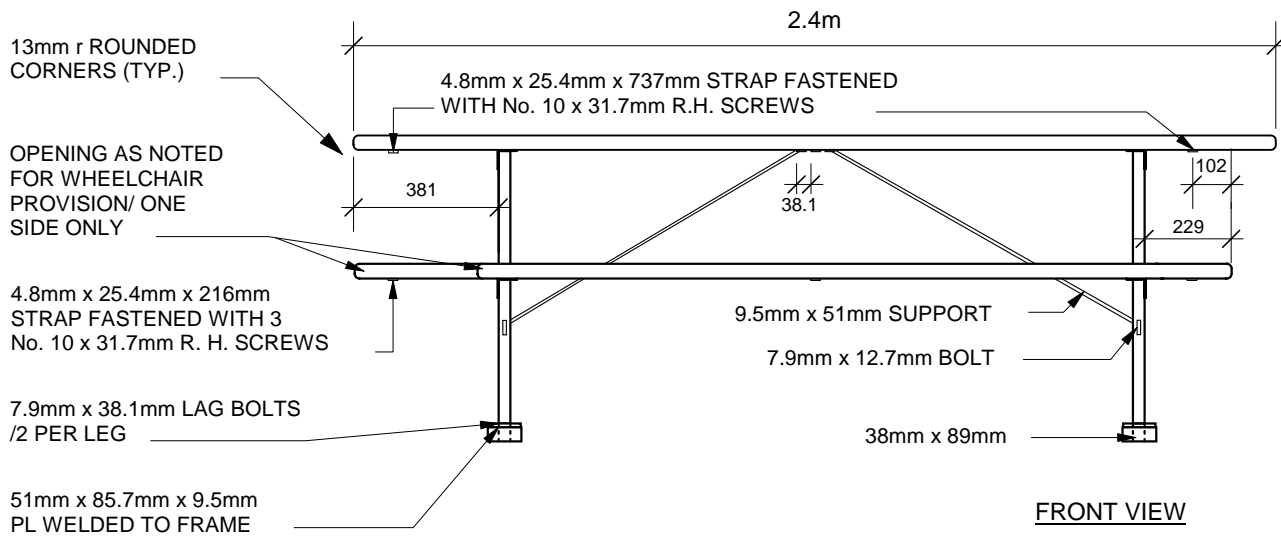
**MATERIALS:**

WOOD - VERTICAL GRAIN CLEAR SITCA SPRUCE OR B.C. RED CEDAR.

FINISH - SIKKENS CETOL No. 078 NATURAL

METAL - PRIME WITH RUSTOLEUM No. 769. FINISH WITH SAPOLIN BLACK WROUGHT FINISH.

**NOTE:**

ALL WOOD TO BE FASTENED TO ANGLE IRONS WITH 7.9mm X 38.1mm LAG BOLTS.

ALL DIMENSIONS SHOWN IN MILLEMETERS.

Model # 52501108

Scale: 1:20

Drawn By: j.f.

Date: Mar./06

THE CITY OF WINNIPEG  
 Planning, Property and Development Department  
 Planning and Land Use Division  
 Unit 15 - 10 Fort Street, Winnipeg, MB, R3C 4X5

