

APPENDIX 'C'

MANITOBA HYDRO STREETLIGHTING STANDARDS



Appendix A
Electrical Standards
(2020 Streetlight Installations)

Refer to electronic copy issued under separate cover

Electric Standards for Streetlight Installations Table of Contents

50-7	Sheet 1 of 1	Ground Rod Material Detail
200-63	Sheet 1 & 2 of 2	Cable Guard Details on DIP/Riser Poles
210-12	Sheets 1 & 2 of 2	Underground Secondary Cable
210-15	Sheet 1 of 1	Standard Underground Secondary Cable Data
210-21	Sheet 1 of 1	Underground Secondary Cable Compression Connectors
210-24	Sheet 1 of 1	Underground Neutral Compression Connectors
215-12	Sheets 1, 2 & 3 of 3	Primary and Secondary Cable End Caps
215-13	Sheets 1 & 2 of 2	Splicing Secondary Neutral (Bare Copper to Insulated Aluminum)
300-1	Sheet 1 of 1	Standard Steel Street Light Poles
300-6	Sheets 1 & 2 of 3	Installation of Precast Concrete Base
300-9	Sheet 1 of 1	Method for Anchor Rod Tightening
300-10	Sheets 1 & 2 of 2	Breakaway Base Installation
300-18	Sheet 1 of 1	Rigging Weights of Street Light Components
300-24	Sheet 1 of 2	Standard LED Luminaires
305-1	Sheets 1 & 2 of 2	Plowing and Trenching Details for Underground Street Light Circuits
310-1	Sheets 1 & 2 of 2	Installation of Street Light Cables
310-3	Sheets 1 to 3 of 3	Raychem Gelcap Splice
310-4	Sheets 1 to 4 of 4	Connection Detail on Steel Street Light Standard
310-9	Sheets 1 to 4 of 4	Street Light Circuit Protected by 30A Fuse in Streetlight Standard
310-10	Sheets 1 to 4 of 4	Street Light Circuit Protected by 15A Fuse in Streetlight Standard
315-1	Sheet 1 of 1	Supply Voltages Street Light Circuits
315-2	Sheet 1 of 1	240/308v for Street Light Circuits
315-5	Sheet 1 of 1	DIP Pole for Underground Street Light Circuit
315-10	Sheet 1 of 1	Control Methods for Street Light Controls
315-12	Sheet 1 of 1	Installation of Externally-Mounted Relay
315-13	Sheet 1 of 1	Connection Schematic for Externally-Mounted Relay
315-35	Sheet 1 of 1	Identification of First Street Light Standard Connected to Circuit

Updated: March 20, 2020

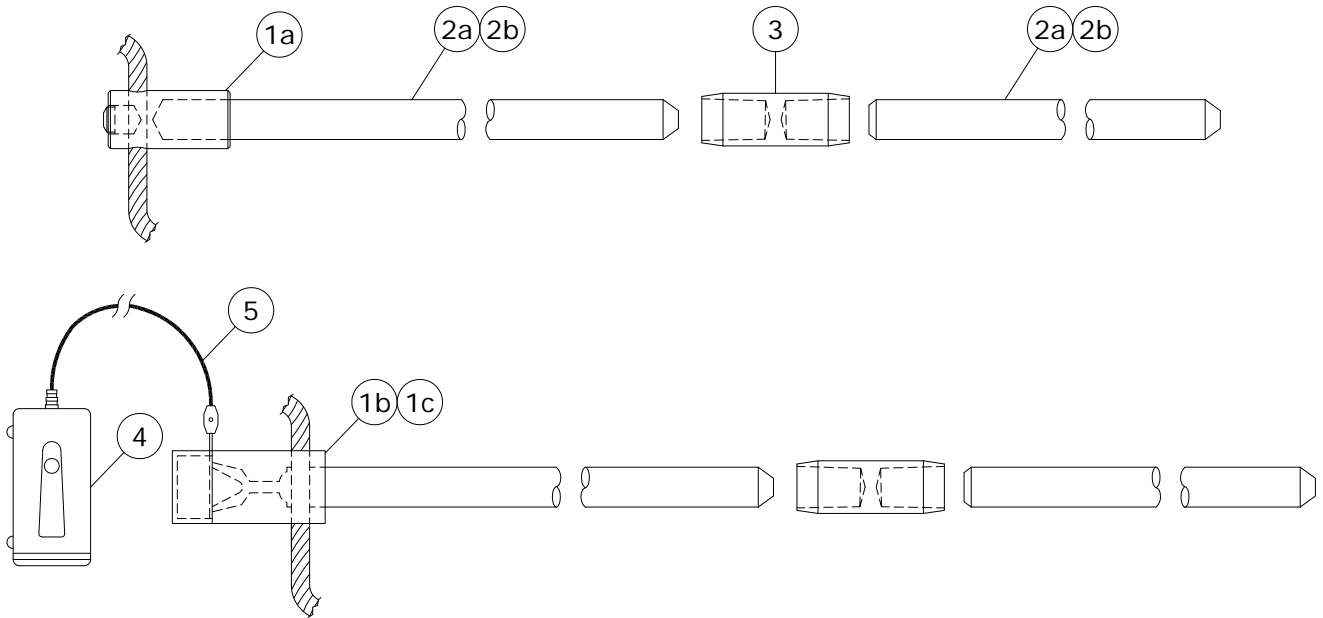

COPPERWELD - SECTIONAL

ITEM No.	DESCRIPTION	MH CIIC
1a	HAMMERLOCK FOR #2 & #4 CU	04 60 24
1b	ONE SHOT PLUS FOR 2/0	03 59 15
1c	ONE SHOT PLUS FOR 4/0	03 77 06
2a	10' CU-WELD ROD SECTIONAL (SEE NOTE 2)	71 70 10
2b	6' CU-WELD ROD SECTIONAL	00 68 26
3	COUPLING CU-WELD	00 52 27
4	ELECTRONIC IGNITER FOR ONE SHOT PLUS WITH 15' CORD	03 59 10
5	15' REPLACEMENT CORD	03 67 43

NOTES:

- FOR 3/4" GROUND RODS. IF A 5/8" GROUND ROD IS ENCOUNTERED, IT IS TO BE REPLACED WITH A 3/4" ROD.
- FIRST GROUND ROD SHALL BE A 10' ROD.

APPROVED ORIGINAL DRAWING SEALED BY E.H. WIEBE 99-01-04	REVISIONS			MANITOBA HYDRO DISTRIBUTION STANDARDS	
	13-01	3	ADDED HAMMERLOCK CONNECTOR	GROUND ROD MATERIAL DETAIL	
	08-07	2	ADDED ELECTRONIC IGNITER & REVISED TABLE		
00-08	1	REMOVED STEEL AND GALVANIZED RODS, ONE SHOT ADDED			
DRAWN R.L.B./CAD	CHECKED D.F./D.O.	DATE 98-08	CD 50-7		SHT 0001 OF 1
					REV 03

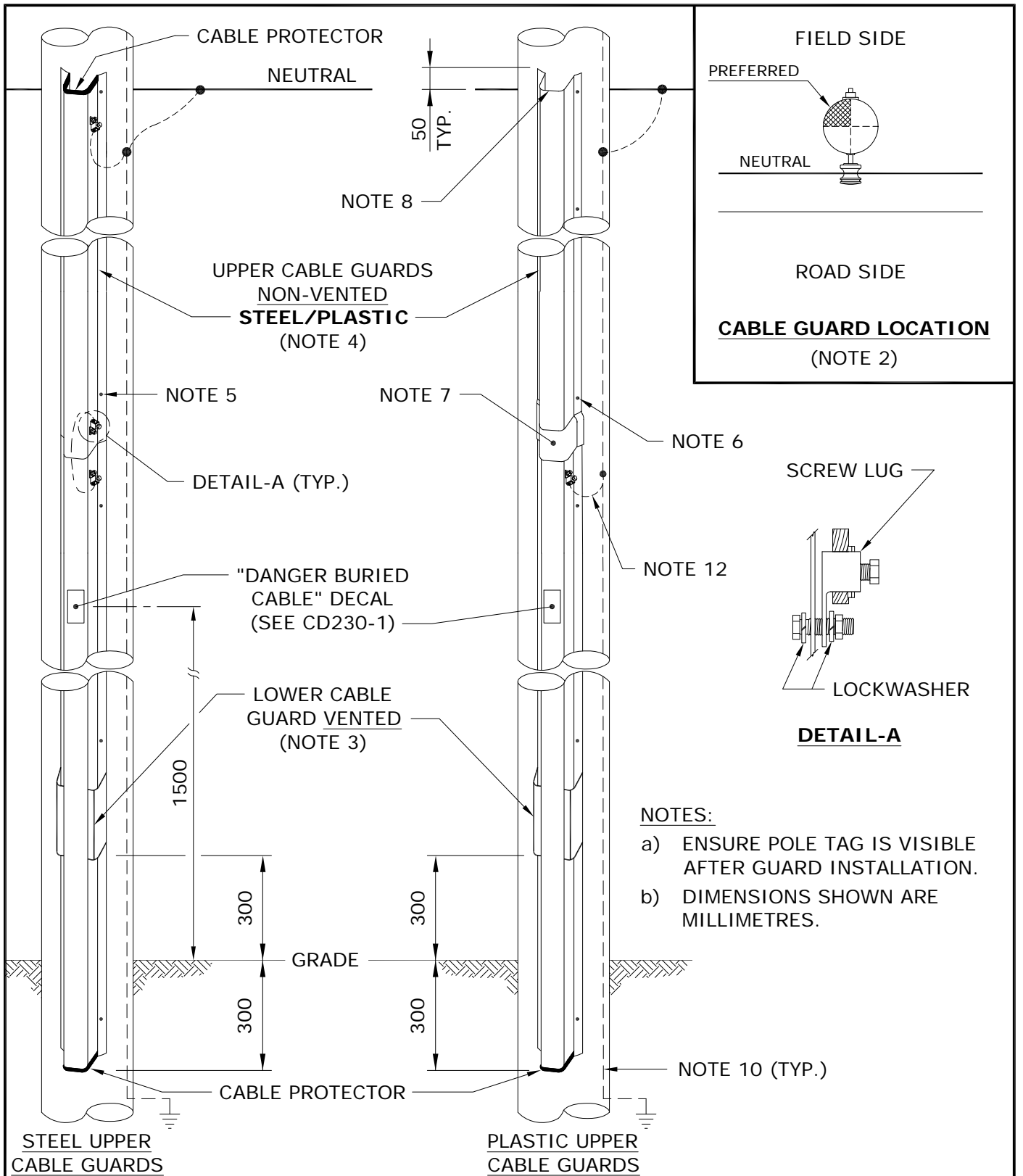

SUPERCEDES ORIGINAL SEALED BY E. WIEBE ON 94-07-03

APPROVED		REVISIONS		MANITOBA HYDRO DISTRIBUTION STANDARDS	
ORIGINAL DRAWING SEALED BY J.J.D. RINGASH 15-10-29	16-04	4	REVISED NOTE	CABLE GUARD DETAILS ON DIP/RISER POLES	
	15-10	3	ADDED NOTE a), RESEALED		
	99-10	2	PLASTIC CABLE GUARD AND SHEET 2 ADDED		
DRAWN C.A.	CHECKED J.R.	DATE 15-10		CD 200-63	
				SHT	REV
				0001 OF 2	04

NOTES:

1. FOR CABLE GUARD SELECTION GUIDE, REFER TO DRAWING CD200-66.
2. TO PROVIDE A SAFER CLIMBING SURFACE AND TO PREVENT VEHICULAR DAMAGE TO THE CABLE GUARD, THE PREFERRED ATTACHMENT OF THE CABLE GUARD TO THE POLE SHOULD BE IN THE QUADRANT AS SHOWN.
3. THE LOWER CABLE GUARD SHALL BE GALVANIZED STEEL AND VENTED.
4. UPPER CABLE GUARD SHALL BE PLASTIC FOR THE 50mm & 90mm GUARDS AND GALVANIZED STEEL FOR THE 130mm GUARD.
5. ATTACH GALVANIZED STEEL CABLE GUARD TO POLE WITH 3/8" LAG SCREWS (72-60-03).
6. ATTACH THE PLASTIC CABLE GUARD TO THE POLE WITH #16 x 2" WOOD SCREWS (72-95-10), C/W FLAT WASHERS (86-10-04).
7. POSITION THE LAP-JOINT OF THE PLASTIC CABLE GUARD DOWN & OVER LAPPED A MINIMUM OF 25mm ONTO THE VENTED CABLE GUARD.
8. ENSURE THAT THE INNER EDGE IS BEVELLED.
9. CABLE GUARD TO EXTEND 50mm ABOVE THE NEUTRAL CONDUCTOR.
10. GROUNDING AND BONDING CONDUCTORS SHALL BE #4 BARE COPPER.
11. FOR GROUNDING CONNECTIONS, REFER TO DRAWING CD200-60.
12. BOND VENTED CABLE GUARD AT THIS POINT.

SUPERCEDES ORIGINAL SEALED BY E. WIEBE ON 99-11-03

APPROVED		REVISIONS		MANITOBA HYDRO DISTRIBUTION STANDARDS		
ORIGINAL DRAWING SEALED BY J.J.D. RINGASH 15-10-29				CABLE GUARD DETAILS ON DIP/RISER POLES		
		16-04	2			ADDED FLAT WASHERS TO NOTE 6
		15-10	1			RESEALED
DRAWN C.A.	CHECKED J.R.	DATE 15-10	CD 200-63		SHT 0002 OF 2	
					REV 02	

SECONDARY CABLE	TYPICAL USAGE
#4 AL. CONCENTRIC NEUTRAL	STREET LIGHT CIRCUITS
1/0 AL. TRIPLEX	SECONDARY RESIDENTIAL SERVICES AND HEAVILY LOADED STREET LIGHT CIRCUITS WHERE VOLTAGE DROP MAY BE A PROBLEM
4/0 AL. TRIPLEX	SECONDARY RESIDENTIAL SERVICES
350 TRIPLEX	SECONDARY RESIDENTIAL SERVICES
4/0 AL. TRIPLEX	THREE PHASE SECONDARY SERVICES ADD #2 Cu BARE NEUTRAL UP TO 200 AMP
350 AL. QUADRAPLEX	THREE PHASE SECONDARY SERVICES 400 AMP OR 200A OVER 75m
750 AL. OR 1000 CU.	THREE PHASE SECONDARY SERVICES OVER 400 AMPS

NOTE:

SEE CD225-4 FOR SIZING AND SPACING OF SINGLE AND THREE PHASE CONDUCTORS.

SUPERCEDES ORIGINAL SEALED BY E. WIEBE ON 88-03-29

APPROVED		REVISIONS		MANITOBA HYDRO DISTRIBUTION STANDARDS	
ORIGINAL DRAWING SEALED BY J.J.D. RINGASH 17-01-25	17-01	11	ADDED 4/0 AL TRIPLEX TO TABLE, RESEALED	UNDERGROUND SECONDARY CABLE	
	06-03	10	ADDED NOTE AND 350 TRIPLEX		
	99-04	9	4/0 AL. TRIPLEX, NOTE CHANGED		
DRAWN C.A.	CHECKED K.S.	DATE 17-01	CD 210-12		SHT 0001 OF 2
					REV 11

BASIC CONSTRUCTION OF UNDERGROUND SECONDARY CABLES

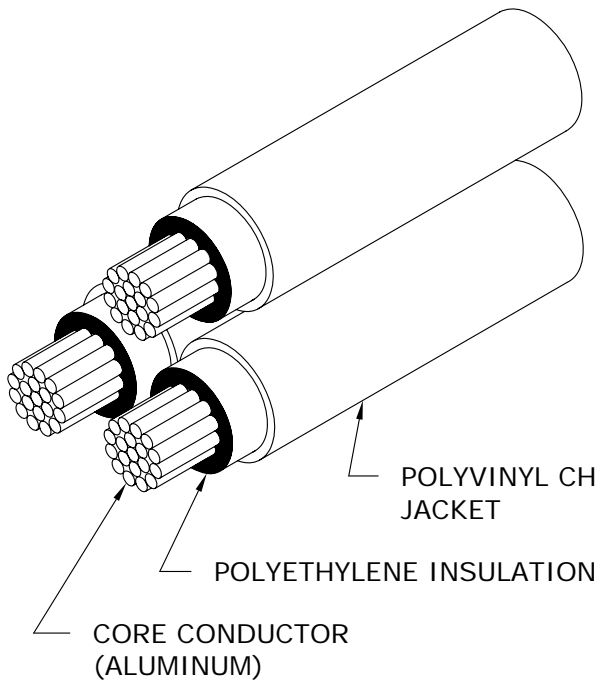

1/0 & 4/0 AND 350 TRIPLEX

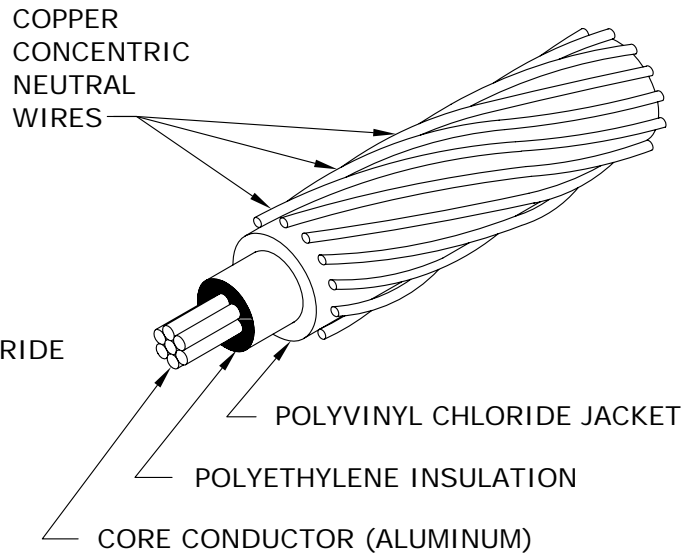

4 CONCENTRIC NEUTRAL CABLE

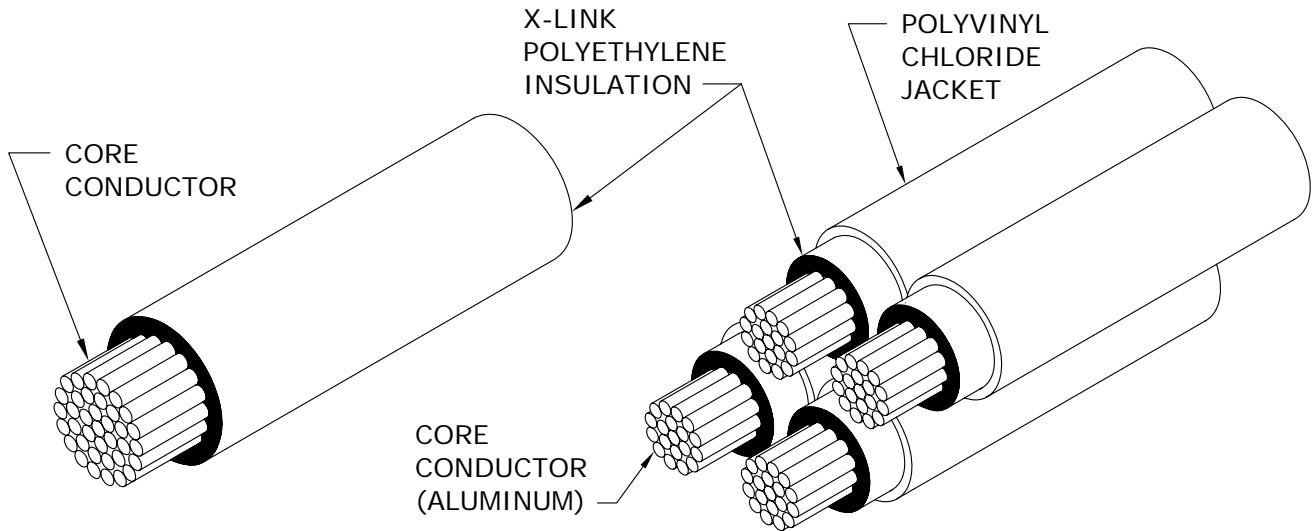

750 kcmil (AL) & 1000 kcmil (CU) RWU

350 kcmil QUADRAPLEX

APPROVED	REVISIONS			MANITOBA HYDRO DISTRIBUTION STANDARDS			
ORIGINAL DRAWING SEALED BY E.H. WIEBE 94-07-03	06-03	2	REPLACED 4/0 TRIPLEX WITH 4/0 & 350 TRIPLEX	UNDERGROUND SECONDARY CABLE			
	95-01	1	C/N WIRES NO LONGER TINNED				
	93-07	0	500 MCM DELETED 350 750 kcmil ADDED FORMERLY CD210-3				
DRAWN W.B./CAD	CHECKED B.H.	DATE 93-07	CD 210-12			SHT 0002 OF 2	REV 02

UNDERGROUND SECONDARY CABLE

VOLTAGE RATING	600V	600V	600V	600V	1000V	1000V	1000V
CORE CONDUCTOR SIZE	#4	1/0	4/0	350 kcmil	750 kcmil	1000 kcmil	1000 kcmil
CORE CONDUCTOR MATERIAL	ALUM.	ALUM.	ALUM.	ALUM.	ALUM.	ALUM.	COPPER
TYPE OF CABLE	C/N	TRIPLEX	TRIPLEX	TRIPLEX OR QUADPLEX	1-COND.	1-COND.	1-COND.
NEUTRAL SIZE AND TYPE	#6 CU. Concentric Neutral	1/0 ALUM.	4/0 ALUM.	350 kcmil ALUM.	NONE	NONE	NONE
MIN. BENDING RADIUS (mm)	125	115	150	180	250	300	300
DC RESISTANCE @ 20°C (OHMS/km)	1.360	0.538	0.269	0.163	0.076	0.057	0.035
** DIRECT BURIED AMPACITY (@ 20°C ambient)	125	215	300	420	* 725	* 840	* 1080
VENTED CABLE GUARD AMPACITY (@ 20°C ambient)	100	175	250	330	575	680	855
*** BURIED DUCT AMPACITY (@ 20°C ambient)	70	130	195	265	425	495	630
CONDUCTOR DIAMETER (mm)	5.4	8.9	12.7	15.8	25	26.9	26.9
NOMINAL DIA. OVER INSUL. (mm)	8.6	12.5	16.5	21.6	31.4	33.5	33.5
NOMINAL DIA. OVER JACKET (mm)	12.74	14.7	17.8	22.8	N/A	N/A	N/A
LINEAL MASS (kg/km)	N/A	760	1320	2200/2900	1330	1369	4983
COLD SHRINK END CAPS (MH CIIC)	N/A	15 31 40	15 31 40	15 31 60	15 31 75	15 31 75	15 31 75
HEAT SHRINK END CAPS (MH CIIC)	03 67 31	03 67 31	03 67 31	03 67 30	01 79 82	03 48 63	03 48 63

* PROVIDED MULTIPLE CONDUCTORS PER PHASE ARE SPACED AS SHOWN IN DRAWING CD225-4.

** CABLES DIRECTLY BURIED OUT OF PADMOUNT TRANSFORMERS OR PEDESTALS.

*** CABLES IN NON-VENTED CABLE GUARDS OR IN CONDUITS LONGER THAN 2 METRES.

SUPERCEDES ORIGINAL SEALED BY E. WIEBE ON 94-07-03

APPROVED ORIGINAL DRAWING SEALED BY J.J.D. RINGASH 16-03-30	REVISIONS		MANITOBA HYDRO DISTRIBUTION STANDARDS					
	17-01	5	REVISED TABLE		STANDARD UNDERGROUND SECONDARY CABLE DATA			
	16-03	4	ADDED 1000 kcmil ALUM. COND., REVISED DATE, RESEALED					
08-12	3	ADDED COLD & HEAT SHRINK CAPS AND LINEAL MASS TO TABLE						
DRAWN C.A.	CHECKED J.R.	DATE 16-03		CD 210-15			SHT 0001 OF 1	REV 05

1-04431-DA-58041-0009

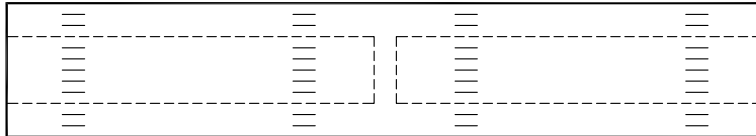

- FOR SPLICING SECONDARY ALUMINUM/COPPER CONDUCTORS.
- NOT SUITABLE FOR USE ON PRIMARY CONDUCTORS.
- COMPLETE WITH BARRIER TO PREVENT MOISTURE MIGRATION.
- FILLED WITH SYNTHETIC INHIBITOR.
- STAMPED WITH CONDUCTOR AND DIE SIZE.
- **COMPRESSION TOOL DIE MUST MATCH DIE NUMBER STAMPED ON CONNECTOR.**
- WIRE BRUSH ALL CONDUCTORS PRIOR TO INSTALLING CONNECTOR.

*** UNDERGROUND SECONDARY CABLE COMPRESSION CONNECTORS**

CONDUCTOR SIZE		STORES CODE	TOOL (DIES)	
FROM	TO		PREFERRED	ALTERNATE
#4	#4	74 27 64	Y35 (UCSA 22)	** MD6 (WCSA 22, BG)
1/0	#2	74 27 30		
1/0	1/0	74 27 65		
4/0	1/0	74 27 67	Y35 (UCSA 24)	** MD6 (WCSA 24, 249)
4/0	4/0	74 27 68		
350	4/0	74 27 78	Y35 (UCSA 28)	---
350	350	74 27 72		
750	500	74 27 27	Y46/ADPT (UCSA 30)	---

* FOR CONNECTING INSULATED ALUMINUM TO BARE COPPER, REFER TO DRAWING CD215-13.

** ROTATE MD6 TOOL 180° AFTER EVERY CRIMP.

APPROVED		REVISIONS		MANITOBA HYDRO DISTRIBUTION STANDARDS					
ORIGINAL DRAWING SEALED BY E.H. WIEBE 94-07-03				UNDERGROUND SECONDARY CABLE COMPRESSION CONNECTORS					
		95-09	2					350-4/0 CONNECTOR ADDED	
		95-01	1					NOTE ON MD6 TOOL ADDED	
DRAWN W.B./CAD	CHECKED G.W.	DATE 93-07		CD 210-21		SHT 0001 OF 1	REV 02		

- COMPRESSION TOOL DIE MUST MATCH DIE NUMBER STAMPED ON CONNECTOR.
- WIRE BRUSH CONDUCTORS PRIOR TO INSTALLING COMPRESSION CONNECTORS.

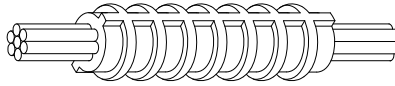

UNDERGROUND NEUTRAL COMPRESSION CONNECTORS			
CONDUCTOR SIZE		STORES CODE	TOOL (DIES)
FROM	TO		
#4	#4	74 32 04	MD6 (162)
#2	#2	74 32 02	MD6 (163)
2/0	2/0	74 31 26	MD6 (166)
4/0	4/0	74 31 28	Y35 (168)
350	350	74 32 31	Y35 (267)

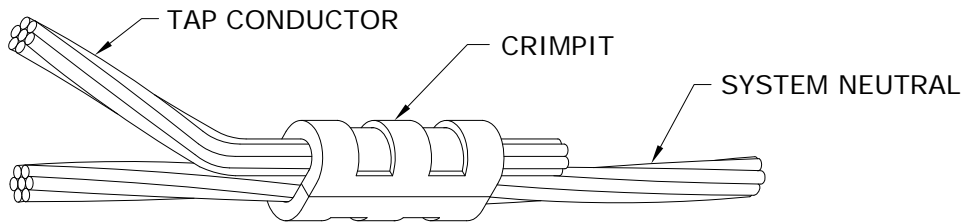

UNDERGROUND NEUTRAL "C" TYPE (CRIMPIT) COMPRESSION CONNECTORS			
* (FOR USE ON COPPER CONDUCTORS ONLY)			
CONDUCTOR SIZE		STORES CODE	TOOL (DIES)
RUN	TAP		
#6 - #4	#6	74 41 10	MD6 (BG)
#4	#4	74 40 90	MD6 (BG)
#2	#4	74 40 80	MD6 (WC)
#2	#2	74 40 70	MD6 (WC)
1/0 - 2/0	1/0 - 2/0	74 41 12	Y35 (UO)
3/0 - 250	#6 - 2/0	74 41 15	Y35 (U997)
3/0 - 250	3/0 - 250	74 41 16	Y35 (U997)
300 - 500	#6 - 2/0	54 23 60	Y46 (P1011)
300 - 500	3/0 - 250	18 30 74	Y46 (P1011)

* FOR CONNECTING BARE COPPER TO INSULATED ALUMINUM, REFER TO DRAWING CD215-13.

APPROVED ORIGINAL DRAWING SEALED BY E.H. WIEBE 94-07-03	REVISIONS		MANITOBA HYDRO DISTRIBUTION STANDARDS		
	10-12	2	ADDED CONNECTOR		
	95-01	1	NOTES REARRANGED		
		93-07	0	CONNECTORS ADDED, FORMERLY CD210-8	
DRAWN W.B./CAD		CHECKED K.C.H.	DATE 93-07	CD 210-24	

THERE ARE THREE METHODS FOR SPLICING 600 VOLT UNDERGROUND SECONDARY CABLES:

- 1) HEAT SHRINK INSULATING TUBING SPLICE
- 2) PRE-STRETCHED INSULATING TUBING SPLICE
- 3) TAPED SPLICE

750 kcmil AND 1000 kcmil CABLES, USED IN CONJUNCTION WITH 3-PHASE COMMERCIAL SERVICES, SHALL NOT BE SPLICED, EXCEPT FOR EMERGENCY REPAIRS.

GENERAL INSTRUCTIONS:

1. a) FOR 1/0 AND 4/0 TRIPLEX CABLES:

- REMOVE ANY DAMAGED OR CONTAMINATED PORTIONS OF CABLE.
- TRAIN CABLES INTO FINAL POSITION (DO NOT SNAKE IN TRENCH).
- CUT CABLES SQUARE AND BUTT ENDS.
- STAGGER SPLICES.
- PROCEED TO STEP 2.

b) FOR #4 CONCENTRIC NEUTRAL CABLE:

- REMOVE ANY DAMAGED OR CONTAMINATED PORTIONS OF CABLE.
- TRAIN CABLES INTO FINAL POSITION WITH ENDS OVERLAPPING C/L BY 150mm.
- TIGHTLY TWIST CONCENTRIC NEUTRAL WIRES INTO A BUNDLED CONDUCTOR FOR APPROXIMATELY 250mm AND TEMPORARILY FOLD BACK.
- CUT OFF APPROXIMATELY 100mm OF CABLE FROM EACH END.
- PROCEED TO STEP 2.

2. SELECT APPROPRIATE SLEEVE AND DIE ACCORDING TO DRAWING CD210-21.

3. SELECT SPLICING METHOD (FOR CORRECT MANUFACTURED SPLICES, REFER TO TABLE ON SHEET 2 of 3).

NOTE:

FOR SPLICING BARE COPPER NEUTRAL WIRE TO INSULATED ALUMINUM CABLE, REFER TO DRAWING CD215-13.

4. REMOVE JACKET AND INSULATION FROM CABLES AS PER FIGURE 1 OR FOLLOW MANUFACTURERS INSTRUCTIONS; BE CAREFUL NOT TO NICK INSULATION OR CONDUCTOR.

5. CLEAN CONDUCTOR WITH WIRE BRUSH. INSTALL CONNECTOR.

NOTE:

EXCEPT FOR TAPED SPLICE, SLIDE TUBING OVER ONE CONDUCTOR BEFORE INSTALLING CONNECTOR.

SUPERCEDES ORIGINAL SEALED BY E. WIEBE ON 94-07-03

APPROVED		REVISIONS			MANITOBA HYDRO DISTRIBUTION STANDARDS		
ORIGINAL DRAWING SEALED BY J.J.D. RINGASH 17-10-11	17-10	3	REMOVED RAYCHEM RAYVOLVE SPLICING, RESEALED		SPLICES FOR UNDERGROUND SECONDARY CABLES		
	96-05	2	NOTES REVISED, SHEET 3 ADDED				
	95-01	1	NOTES 3, 7 & TABLE ADDED				
DRAWN C.A.	CHECKED K.S.	DATE 17-10		CD 215-12		SHT 0001 OF 3	REV 03

6. CLEAN JACKET (50mm), INSULATION, AND CONNECTOR WITH AN APPROVED CLEANING SOLVENT (S.C.# 43 11 95).

7. COMPLETE SELECTED SPLICE (AS CHOSEN IN STEP 3).

NOTE:

TO COMPLETE #4 CONCENTRIC NEUTRAL SPLICE, PROCEED TO STEP 8.

8. FOR #4 CONCENTRIC NEUTRAL CABLE: (CONT'D)

- a) APPLY 1 LAYER OF 1/4 STRETCHED 50mm WIDE RUBBER MASTIC TAPE (S.C.#78 55 28) OVER CENTRE OF COMPLETED SPLICE.
- b) TRAIN TWISTED CONCENTRIC NEUTRAL WIRE (STEP 1b) INTO FINAL POSITION ALLOWING ADEQUATE CLEARANCE FOR MD6 PRESS.
- c) PLACE "C" TYPE COMPRESSION CONNECTOR OVER TWISTED WIRES AND CRIMP. REFER TO DRAWING CD210-24.
- d) TRIM OFF PROTRUDING WIRES AND COMPRESS WITH PLIERS ELIMINATING ANY SHARP ENDS.
- e) APPLY A 100mm STRIP OF 50mm WIDE RUBBER MASTIC TAPE OVER CONNECTOR AND PROTRUDING WIRES.

NOTE:

SHINY SIDE AGAINST CONNECTOR AND THE 100mm LENGTH PARALLEL TO CONNECTOR AND WIRE.

- f) FORM TAPED CONCENTRIC NEUTRAL CONNECTION AND WIRES AROUND SPLICE AND CABLE.
- g) APPLY 2 LAYERS 3/4 STRETCHED COLD WEATHER VINYL TAPE (S.C.#78 55 98) OVER TAPED CONCENTRIC NEUTRAL CONNECTION AND SPLICE, APPROXIMATELY 50mm WIDE.

MANUFACTURED SPLICES FOR SECONDARY CABLES		
CONDUCTOR SIZE	TYPE OF SPLICE	STORES CODE
#4 TO 1/0	PRESTRETCHED	85 13 10
4/0 TO 350	PRESTRETCHED	85 13 40
	HEAT SHRINK	85 13 50

SUPERCEDES ORIGINAL SEALED BY E. WIEBE ON 94-07-03

APPROVED ORIGINAL DRAWING SEALED BY J.J.D. RINGASH 17-10-11	REVISIONS		MANITOBA HYDRO DISTRIBUTION STANDARDS	
	17-08	4	SPLICES FOR UNDERGROUND SECONDARY CABLES	
	15-02	3		
08-03	2			
DRAWN C.A.	CHECKED K.S.	DATE 17-08	CD 215-12	
			SHT 0002 OF 3	REV 04

FOR TAPED SPLICE

TAPES SHALL ONLY BE APPLIED DIRECTLY FROM ROLL ONTO SPLICE, HALF LAPPED AND STRETCHED TO 3/4 OF THEIR ORIGINAL WIDTH.

1. APPLY 3 LAYERS OF SELF-AMALGAMATING ETHYLENE PROPYLENE RUBBER (E.P.R.) TAPE (S.C.#78 55 23) AS PER FIGURE 2.
2. APPLY 2 LAYERS OF COLD WEATHER VINYL TAPE (S.C.#78 55 98) AS PER FIGURE 2.

OR

APPLY 3 LAYERS OF SELF-AMALGAMATING HIGH TEMPERATURE SILICONE TAPE (S.C.#03 74 67). VINYL TAPE IS NOT REQUIRED.

NOTE:
DIMENSIONS SHOWN ARE MILLIMETRES.

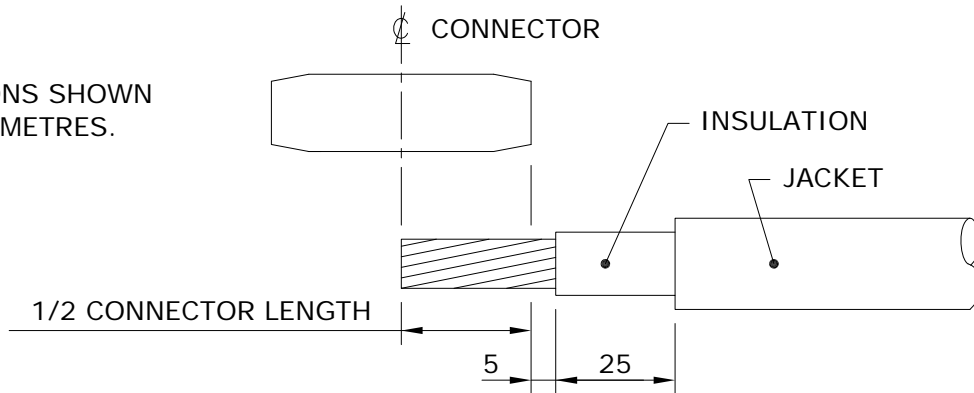

FIGURE 1

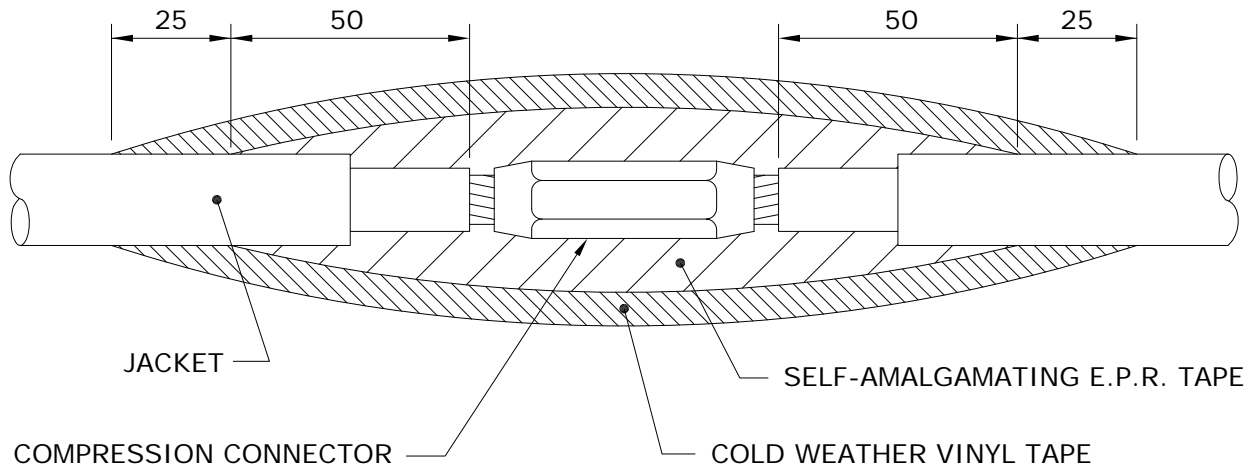

FIGURE 2

SUPERCEDES ORIGINAL SEALED BY E. WIEBE ON 97-01-08

APPROVED		REVISIONS		MANITOBA HYDRO DISTRIBUTION STANDARDS		
ORIGINAL DRAWING SEALED BY J.J.D. RINGASH 17-10-11				SPLICES FOR UNDERGROUND SECONDARY CABLES		
		17-10	2			RESEALED
		10-12	1			REVISED COMPRESSION CONNECTOR AND NOTE 2
DRAWN C.A.	CHECKED K.S.	DATE 17-10	CD 215-12		SHT 0003 OF 3	
					REV 02	

CABLE PREPARATION:

- ① REMOVE PVC (POLYVINYL CHLORIDE) JACKET TO DIMENSION "A" PLUS 25mm.
- ② REMOVE POLYETHYLENE INSULATION TO DIMENSION "A" PLUS 5mm.
USE ABRASIVE TAPE (SC. 78 50 04) ON ALL CONNECTON SURFACES.
- ③ INSTALL ROD CONNECTOR AS PER TABLE BELOW AND FIGURE 1.

CONDUCTOR SIZE	* ROD CONNECTOR STORES CODE No.	PRESS	DIE
1/0 ALUMINUM	74 27 62	Y35/MD6	CSA 22
4/0 ALUMINUM	74 27 69	Y35/MD6	CSA 24

* ROD IS FACTORY CRIMPED INTO CONNECTOR

- ④ CONNECT BARE COPPER STRANDED WIRE TO ROD CONNECTOR AS PER TABLE BELOW. USE ABRASIVE TAPE ON ALL CONNECTON SURFACES.

CONDUCTOR SIZE	CONNECTOR STORES CODE No.	PRESS	DIE
COPPER ROD TO #4 COPPER STRANDED	74 40 90	Y35/MD6	WBG
COPPER ROD TO #2 COPPER STRANDED	74 40 70	MD6	WC

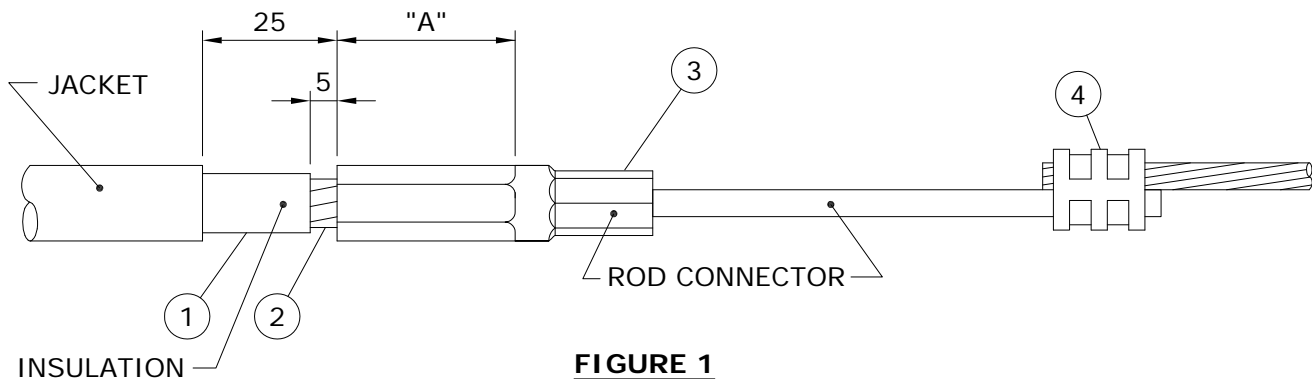

FIGURE 1

NOTE: DIMENSIONS SHOWN ARE MILLIMETRES.

APPROVED	REVISIONS		MANITOBA HYDRO DISTRIBUTION STANDARDS		
ORIGINAL DRAWING SEALED BY E.H. WIEBE 94-07-03			SPLICING SECONDARY NEUTRAL (BARE COPPER TO INSULATED ALUMINUM)		
	08-11	2			REVISED TABLE AND COMPRESSION CONNECTOR
	94-10	1			ROD CONNECTOR ADDED
DRAWN W.B./CAD	CHECKED B.H./K.C.H.	DATE 94-06	CD 215-13		
			SHT 0001 OF 2	REV 02	

TAPING:

- 5 ABRASE ROD PORTION OF ROD CONNECTOR WITH ABRASIVE TAPE AS SHOWN IN FIGURE 2.
- 6 CLEAN JACKET, INSULATION & ROD CONNECTOR WITH AN APPROVED CLEANING SOLVENT (S.C.# 43 11 95).
- 7 CUT ONE PIECE OF RUBBER MASTIC TAPE (S.C. 78 55 28) INTO EITHER A 50mm WIDE x 75mm LONG STRIP FOR 1/0 CONNECTOR OR A 50mm WIDE x 125mm LONG STRIP FOR 4/0 CONNECTOR.
- 8 APPLY THE PRECUT STRIP OF RUBBER MASTIC TAPE 1/4 STRETCHED, SHINING SIDE DOWN ONTO THE ROD AS SHOWN IN FIGURE 2.
- 9 APPLY 2 LAYERS OF HALF LAPPED 3/4 STRETCHED SELF AMALGAMATING ETHYLENE PROPYLENE RUBBER TAPE (S.C.# 78 55 23) AS SHOWN IN FIGURE 2.
- 10 APPLY 2 LAYERS OF HALF LAPPED 3/4 STRETCHED COLD WEATHER VINYL TAPE (S.C.# 78 55 98) AS SHOWN IN FIGURE 2.

NOTE:

WHEN INSTALLING A MANUFACTURED SPLICE INCLUDE STEPS 5 THRU 8 WITH THE MANUFACTURERS INSTRUCTIONS. THIS WILL PROVIDE THE PROPER INSULATION AND MOISTURE SEAL.

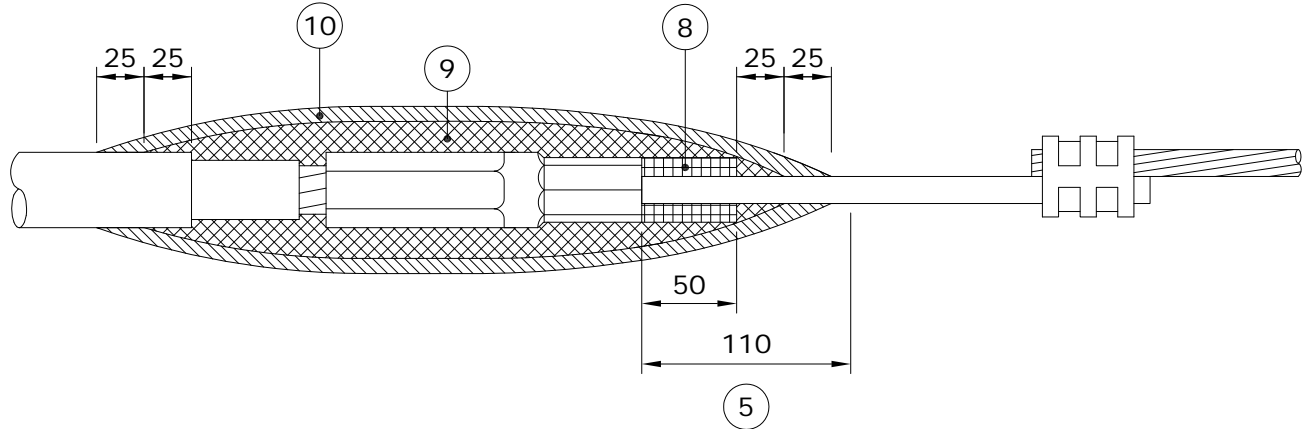
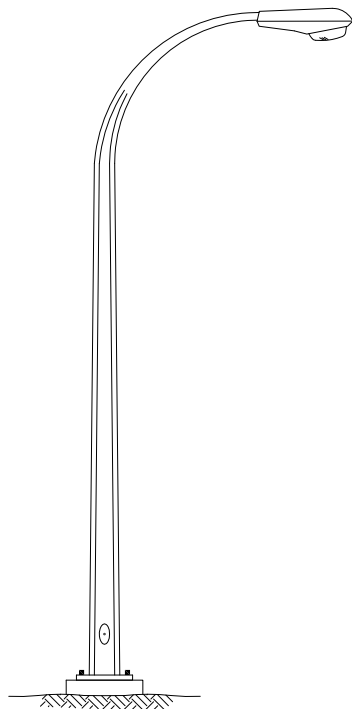

FIGURE 2

NOTE: DIMENSIONS SHOWN ARE MILLIMETRES.

APPROVED		REVISIONS		MANITOBA HYDRO DISTRIBUTION STANDARDS		
ORIGINAL DRAWING SEALED BY E.H. WIEBE 94-07-03				SPLICING SECONDARY NEUTRAL (BARE COPPER TO INSULATED ALUMINUM)		
		08-11	2			REVISED NOTE 6 & COMPRESSION CONNECTOR
		94-10	1			TAPING PROCEDURE REVISED
DRAWN W.B./CAD	CHECKED K.C.H.	DATE 94-06	CD 215-13		SHT 0002 OF 2	
					REV 02	



DAVIT BM
(BASE MOUNTED)

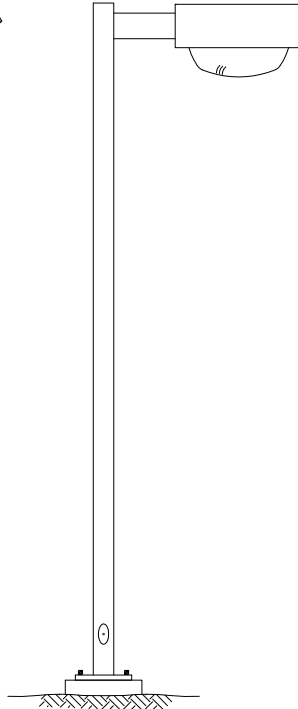

SQUARE BM
(BASE MOUNTED)

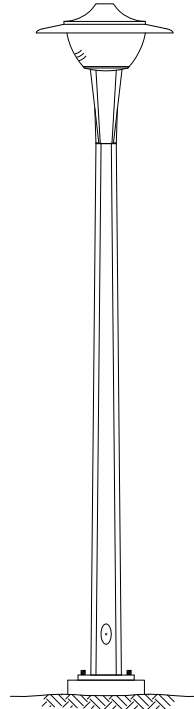

**POST-TOP
CONTEMPORARY BM**
(BASE MOUNTED)

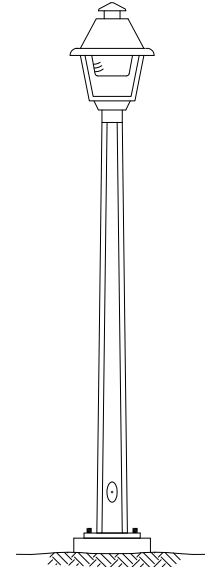

**POST-TOP
COLONIAL BM**
(BASE MOUNTED)

POLE TYPE	COLOUR	MOUNTING HEIGHT m (ft)	ARM REACH m	BOLT SQUARE mm	BOLT CIRCLE mm	STORES CODE NO.	CABLE LENGTH m **
DAVIT BM	GALVANIZED	7.7 (25)	1.8	179	254	75 42 26	11
DAVIT BM *	GALVANIZED	9.1 (30)	2.4	197	279	75 43 30	13
DAVIT BM	GALVANIZED	10.7 (35)	3.0	206	292	75 44 36	15
DAVIT BM	GALVANIZED	13.7 (45)	3.0	243	343	75 46 45	18
SQUARE BM	DARK BRONZE	6.1 (20)	0.5	179	254	75 42 20	8
SQUARE BM	DARK BRONZE	10.7 (35)	0.5	206	292	75 45 30	14
POST-TOP BM CONTEMPORARY	GALVANIZED	6.1 (20)	N/A	179	254	75 41 22	7
POST-TOP BM COLONIAL	GALVANIZED	4.7 (15)	N/A	179	254	75 41 15	6

NOTES:

* FOR REPLACEMENT PURPOSES; NOT TO BE USED FOR NEW INSTALLATIONS.

** LENGTH OF 2 CONDUCTORS #12 CABLE REQUIRED PER POLE.

APPROVED		REVISIONS		MANITOBA HYDRO DISTRIBUTION STANDARDS			
ORIGINAL DRAWING SEALED BY E.H. WIEBE 89-04-28	13-01	3	ADDED CONTEMPORARY AND COLONIAL POLES	STANDARD STEEL STREET LIGHT POLES			
	12-05	2	REVISED DRAWING & CANCELLED SHEETS 2 AND 3				
	94-09	1	DELETED ORNAMENTAL				
DRAWN W.B./CAD	CHECKED L.D./D.O.	DATE 88-06	CD 300-1		SHT 0001 OF 1	REV 03	

7.7 - 10.7 STREET LIGHT POLES

NOTES:

1. FOR FUTURE ACCESS TO LOWER PORTION OF PLASTIC PIPE, LOCATE "V" GROOVE SIDE OF BASE TO ROADWAY PROVIDED THAT:
 - a) A MIN. HORIZONTAL SEPARATION OF 350mm IS MAINTAINED TO ANY PAVED SURFACE OR STRUCTURE; OR
 - b) IF LESS THAN 350mm, ROTATE BASE 90°
2. ROUTE UNDERGROUND CABLES DIRECTLY INTO PLASTIC PIPE.
3. IN BACKFILL AREA, ENCASE UNDERGROUND CABLES IN A 75mm RADIUS ENVELOPE OF EXCAVATED MATERIAL OR SAND TO PROTECT CABLES. DO NOT BACKFILL WITH EXCAVATED MATERIAL OR SAND MORE THAN 1/6 OF THE WAY AROUND BASE.
4. SEE CD300-9 FOR ANCHOR ROD TIGHTENING METHOD.
5. DIMENSIONS SHOWN ARE MILLIMETRES.

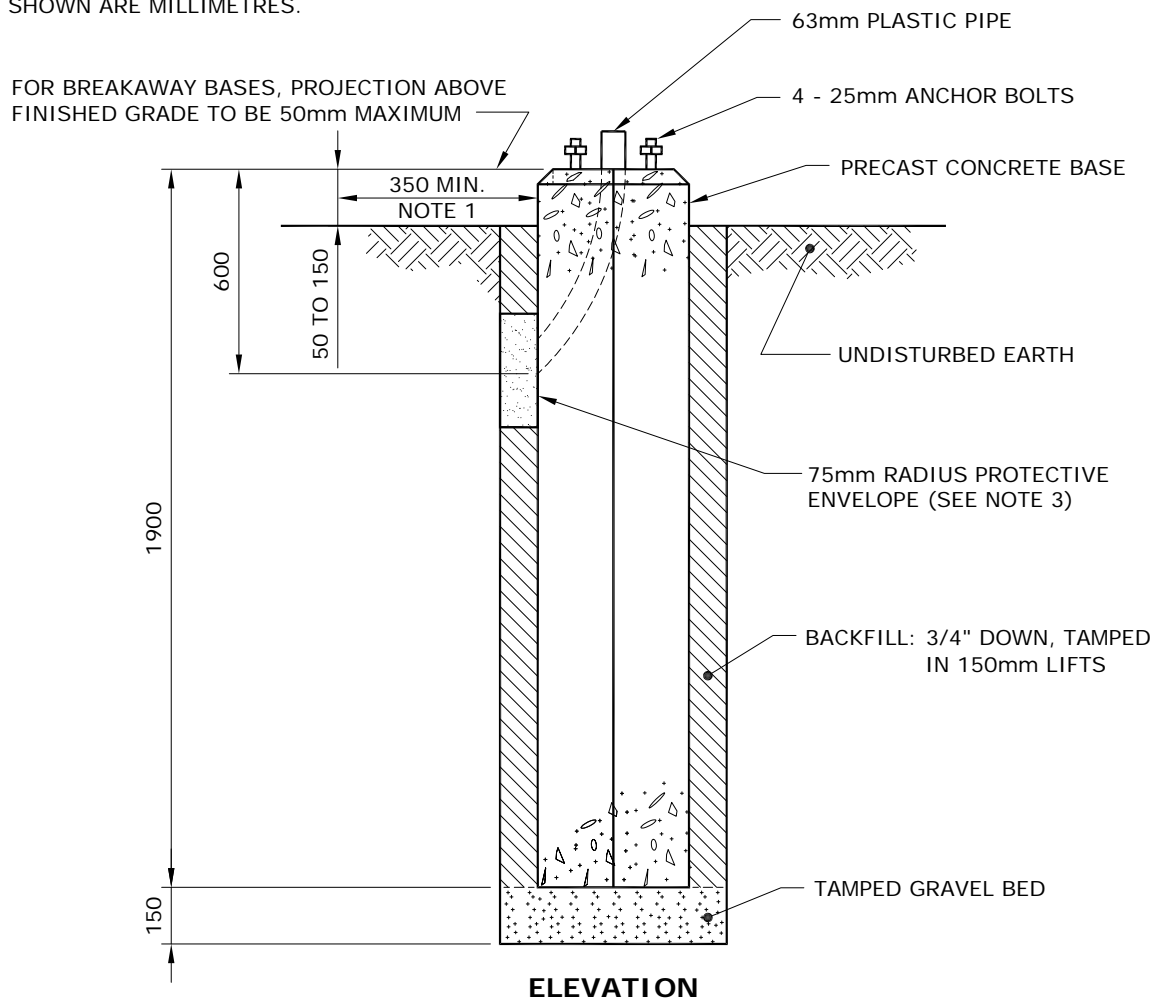
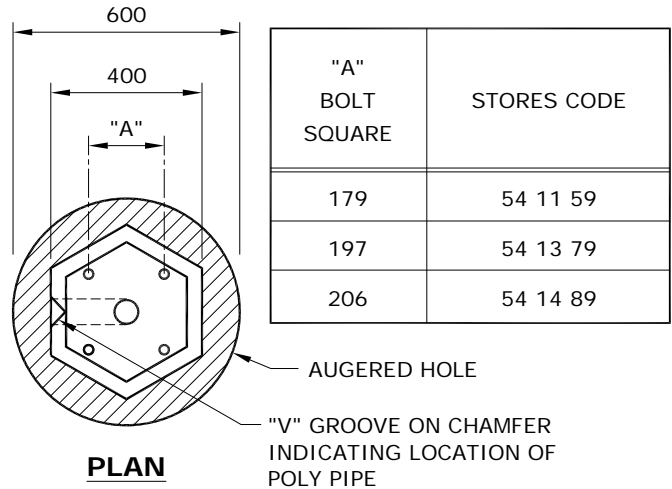

APPROVED	REVISIONS			MANITOBA HYDRO DISTRIBUTION STANDARDS			
ORIGINAL DRAWING SEALED BY E.H. WIEBE 89-04-29	10-08	3	CHANGED BACKFILL NOTES, AND ADDED SHEET 3	INSTALLATION OF PRECAST CONCRETE BASE			
	99-05	2	SHEET 2 of 2 ADDED, 7.7 - 10.7 STREET LIGHT ADDED				
	96-10	1	V-GROOVE LOCATION, POLY PIPE SIZE NOTES CHANGED				
DRAWN W.B./CAD	CHECKED L.D./K.C.H.	DATE 88-06	CD 300-6			SHT 0001 OF 3	REV 03

13.7 STREET LIGHT POLE

NOTES:

1. FOR FUTURE ACCESS TO LOWER PORTION OF PLASTIC PIPE, LOCATE "V" GROOVE SIDE OF BASE TO ROADWAY PROVIDED THAT:
 - a) A MIN. HORIZONTAL SEPARATION OF 350mm IS MAINTAINED TO ANY PAVED SURFACE OR STRUCTURE; OR
 - b) IF LESS THAN 350mm, ROTATE BASE 90°
2. ROUTE UNDERGROUND CABLES DIRECTLY INTO PLASTIC PIPE.
3. IN BACKFILL AREA, ENCASE UNDERGROUND CABLES IN A 75mm RADIUS ENVELOPE OF EXCAVATED MATERIAL OR SAND TO PROTECT CABLES. DO NOT BACKFILL WITH EXCAVATED MATERIAL OR SAND MORE THAN 1/6 OF THE WAY AROUND BASE.
4. SEE CD300-9 FOR ANCHOR ROD TIGHTENING METHOD.
5. DIMENSIONS SHOWN ARE MILLIMETRES.

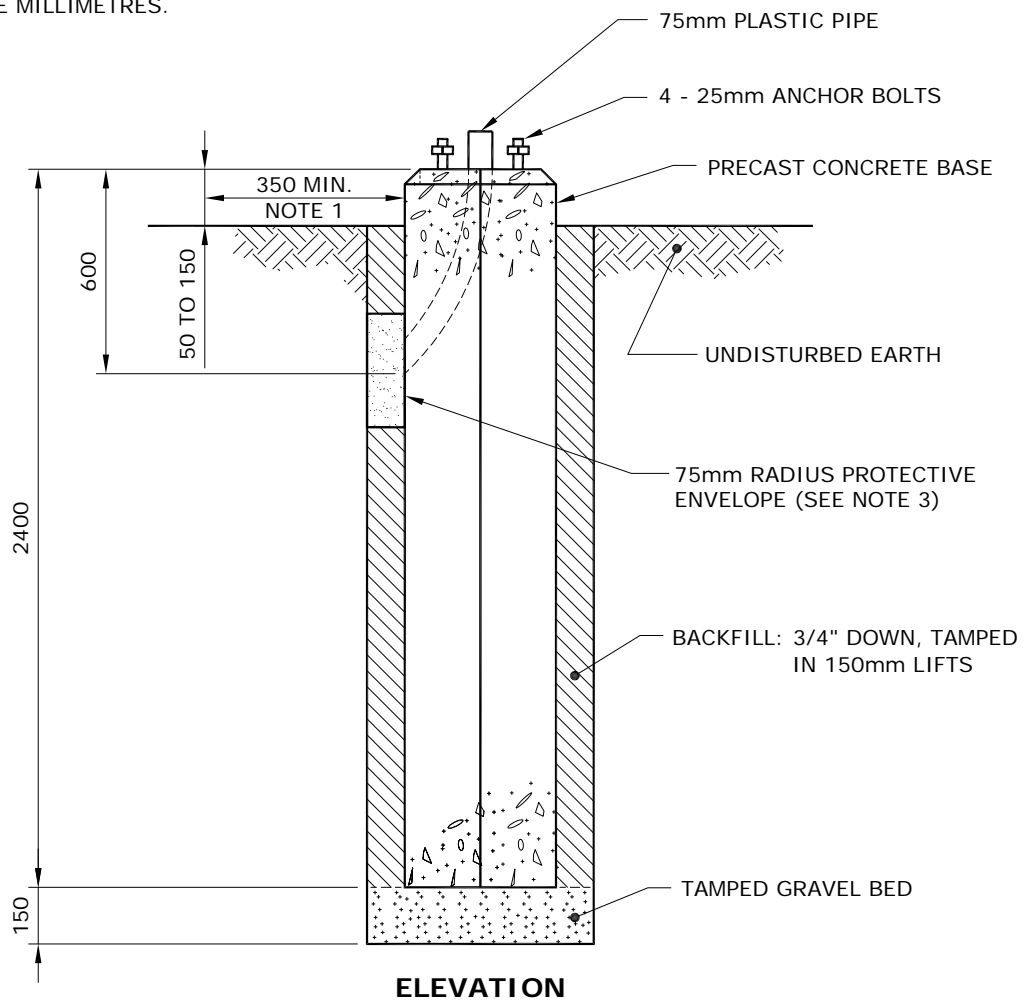
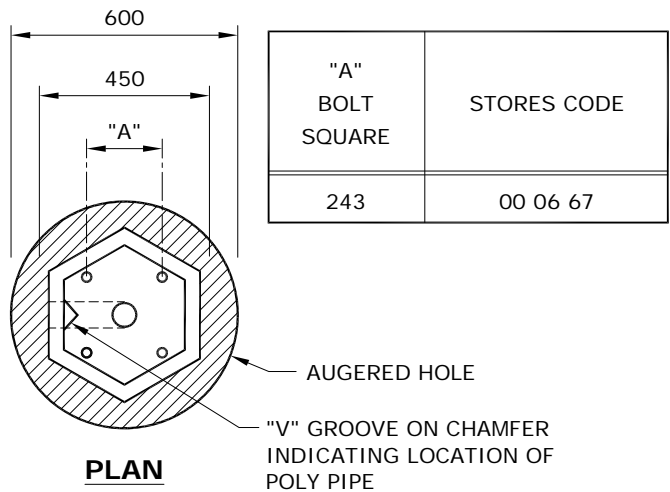

APPROVED	REVISIONS	MANITOBA HYDRO DISTRIBUTION STANDARDS	
ORIGINAL DRAWING SEALED BY E.H. WIEBE 89-04-29		INSTALLATION OF PRECAST CONCRETE BASE	
	10-08 1 CHANGED BACKFILL NOTES, AND ADDED SHEET 3		
DRAWN R.L.B./CAD	CHECKED L.D./K.C.H.	DATE 99-05	CD 300-6
			SHT 0002 OF 3
			REV 01

TO DEVELOP THE REQUIRED TENSION ON ANCHOR RODS, THE TURN-OF-NUT METHOD IS USED.

TURN-OF-NUT

1. ENSURE ALL ANCHOR RODS AND NUTS ARE FREE OF DEBRIS AND THAT THE ANCHOR RODS ARE LUBRICATED.
2. PLACE POLE ONTO CONCRETE PILE, INSTALL WASHERS AND NUTS AND TIGHTEN UNTIL DEVELOPING A SNUG-TIGHTENED CONNECTION.

SNUG-TIGHTENED: THE TIGHTNESS THAT IS ATTAINED AFTER A FEW IMPACTS OF AN IMPACT WRENCH OR THE FULL FORCE OF A WORKER USING AN ORDINARY ONE FOOT LONG WRENCH.

3. TIGHTENING OF THE BOLTS MUST BE PERFORMED IN A MANNER THAT BRINGS THE FAYING SURFACES UP "EVENLY" AS PER THE STAR PATTERN TIGHTENING SEQUENCE.

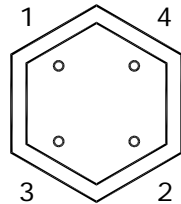

FOUR ANCHOR BOLT PATTERN
(13.7m AND BELOW)

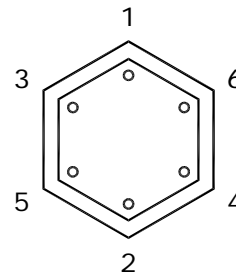

SIX ANCHOR BOLT PATTERN
(16.8m AND 19.8m)

4. ENSURE THE POLE IS PLUMB AND ADD LEVELING SHIMS IF REQUIRED. SNUG-TIGHTEN THE ANCHOR BOLTS AGAIN.
5. BEVELED WASHERS ARE REQUIRED IF THE NUT CANNOT BE BROUGHT INTO FIRM CONTACT WITH THE BASE PLATE.
6. MARK THE REFERENCE LOCATION OF THE NUT AFTER SNUG-TIGHTENING THE PLUMB POLE.
7. FINAL TIGHTENING OF NUTS IS PERFORMED IN INCREMENTS AS PER THE STAR PATTERN, WITH A MINIMUM OF TWO FULL TIGHTENING CYCLES. PROPER TENSIONING IS ACHIEVED WHEN THE NUT IS ROTATED 1/3 OF A TURN BEYOND SNUG-TIGHT. THE TOLERANCE FOR THIS IS PLUS 20°.

APPROVED	REVISIONS		MANITOBA HYDRO DISTRIBUTION STANDARDS	
ORIGINAL DRAWING SEALED BY K.C. HAMILTON 10-08-13			METHOD FOR ANCHOR ROD TIGHTENING	
DRAWN C.A.	CHECKED L.D.	DATE 10-08	CD 300-9	
			SHT 0001 OF 1	REV 00

THE FOLLOWING INSTALLATION INSTRUCTIONS ARE APPLICABLE TO NEW OR EXISTING BREAKAWAY BASE INSTALLATIONS ON CONCRETE BASES.

PROCEDURE:

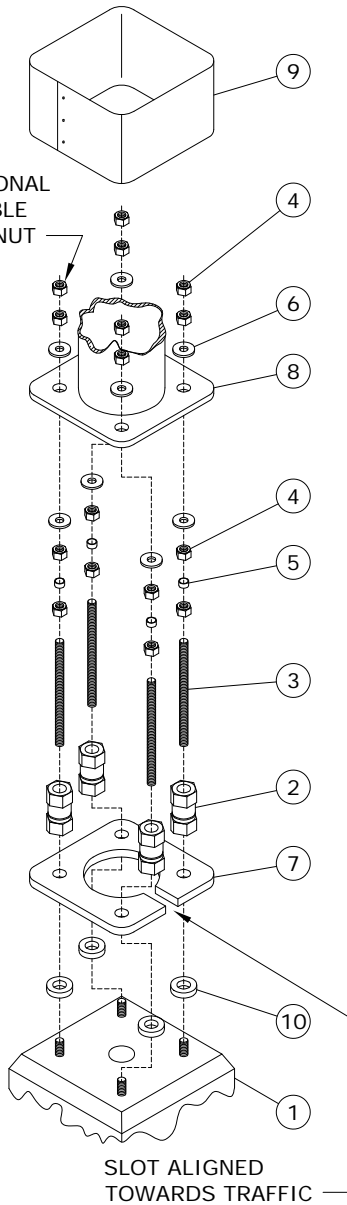

1. CLEAN THE TOP SURFACE OF THE CONCRETE BASE AND ENSURE SURFACE IS FLAT AND LEVEL WITH NO SPALLING OR OTHER SURFACE CONDITIONS THAT MAY AFFECT THE PERFORMANCE OF THE COUPLERS.
 2. THE PREFERRED MAXIMUM HEIGHT ABOVE LEVEL GRADE TO THE BASE OF THE COUPLER IS 50mm OR LESS. THIS PROVIDES THE RECOMMENDED CLEARANCE IN THE EVENT OF A COLLISION WITH THE STRUCTURE.
 3. MEASURE THE HEIGHT OF THE THREADED ANCHOR BOLTS ABOVE THE REACTION PLATE AND VERIFY THIS MEASUREMENT IS BETWEEN 1 1/4" AND 1 5/8".
 4. IF THE EXPOSED LENGTH OF THE ANCHOR BOLT IS GREATER THAN THE RECOMMENDED LENGTH, OPTIONAL SPACERS MAY BE USED (ITEM 10).
 5. IT IS RECOMMENDED THAT THE THREADED ANCHOR BOLT-COUPLER CONNECTION BE COATED WITH RUST-INHIBITING GREASE. THIS WILL FACILITATE REMOVAL OF THE COUPLER WHEN IT IS NECESSARY. A SUITABLE PRODUCT FOR THIS APPLICATION IS ARCAN 1, A WHITE, WATER RESISTANT GREASE MARKETED BY IMPERIAL OIL LTD.
 6. THREAD THE COUPLER ASSEMBLY ON EACH ANCHOR BOLT (IF THE COUPLER ASSEMBLY UPPER STUD BECOMES LOOSE AS A RESULT OF HANDLING, ENSURE THAT THE STUD IS ENGAGED AT LEAST 38mm, BUT NOT MORE THAN 44mm IN THE COUPLER BEFORE LOCKING WITH THE LOCK NUT.)
 7. SNUG UP EACH COUPLER AGAINST THE CONCRETE BASE. TIGHTEN EACH COUPLER ALTERNATELY AND INCREMENTALLY, BY MEANS OF A WRENCH OR A PIPE WRENCH ON THE BOTTOM HEX OF THE COUPLER. USE THE TURN-OF-NUT METHOD AS PER CD300-9.
- NOTE: TIGHTENING THE COUPLER ON THE TOP HEX MAY WEAKEN THE COUPLER AT THE MACHINED GROOVE AND MAKE THE COUPLER UNUSEABLE.**
8. BRING THE LEVELING NUTS (AND HENCE, THE LOWER WASHERS) INTO A LEVEL PLANE AS DESIRED MAKING CERTAIN THAT AT LEAST ONE PLASTIC SPACER REMAINS IN CONTACT WITH ITS LEVELING NUT AND ITS LOCK NUT.
 9. PLACE THE POLE BASE OVER THE PROTRUDING STUDS, AND SECURE THE POLE WITH THE UPPER WASHERS AND RETAINING NUTS.
 10. WITH THE POLE IN THE REQUIRED VERTICAL ORIENTATION, AND BEFORE FINAL TIGHTENING, ENSURE THAT ALL LEVELING NUTS, RETAINING NUTS AND UPPER AND LOWER WASHERS ARE MADE SNUG AGAINST THE POLE BASE PLATE.
 11. TIGHTEN THE RETAINING NUTS WITH THE TURN-OF-NUT METHOD AS PER CD300-9.
 12. MAKE THE NECESSARY WIRING CONNECTIONS, AND INSTALL THE PROTECTIVE SHROUD.

SUPERCEDES ORIGINAL SEALED BY E. WIEBE ON 89-04-28

APPROVED		REVISIONS		MANITOBA HYDRO DISTRIBUTION STANDARDS	
ORIGINAL DRAWING SEALED BY D.R. ORR 16-06-27	16-06	4	CORRECTED TYPO, RESEALED	BREAKAWAY BASE INSTALLATION	
	10-08	3	UPDATED STANDARD, REVISED TITLE, AND ADDED SHEET 2		
	07-06	2	REVISED NOTE 4 AND ADDED NOTE 5		
DRAWN C.A.	CHECKED L.D.	DATE 16-06		CD 300-10	
				SHT 0001 OF 2	REV 04

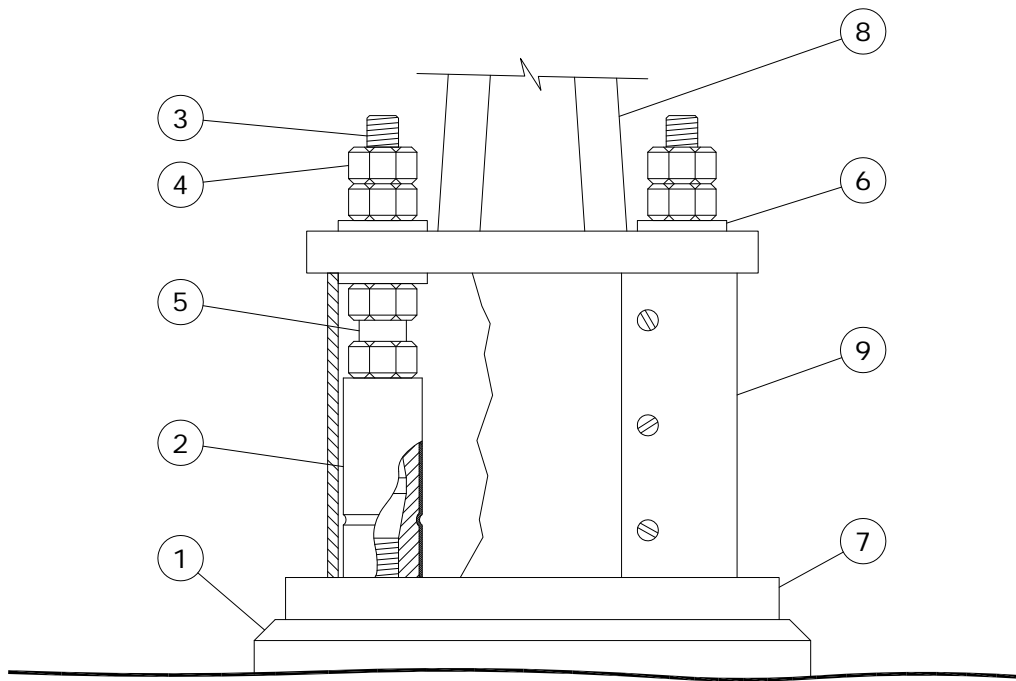

BILL OF MATERIAL

ITEM NO.	DESCRIPTION	QUANTITY
1	CONCRETE BASE	1
2	COUPLING	4
3	1" - 8 UNC GALV. STUD	4
4	1" - 8 UNC GALV. HEAVY HEX NUT	16
5	SPACER	4
6	1" GALV. FLAT WASHER	8
7	REACTION PLATE	1
8	POLE	1
9	SHROUD ASSEMBLY	1
10	GALV. SHIM	4

APPROVED ORIGINAL DRAWING SEALED BY K.C. HAMILTON 10-08-13	REVISIONS		MANITOBA HYDRO DISTRIBUTION STANDARDS		
			BREAKAWAY BASE INSTALLATION		
DRAWN C.A.	CHECKED L.D.	DATE 10-08	CD 300-10	SHT 0002 OF 2	REV 00

STREET LIGHT POLES *

POLE TYPE	MOUNTING HEIGHT m (ft)	MATERIAL	WEIGHT *, ** kg (±10%)
STRAIGHT SHAFT	10.7 (35)	ALUMINUM	91
DAVIT (DB)	11.3 (37)	CONCRETE	998
DAVIT (DB)	13.7 (45)	CONCRETE	1087
POST TOP (DB)	6.1 (20)	CONCRETE	544
DAVIT	7.7 (25)	STEEL	97
DAVIT	9.1 (30)	STEEL	125
DAVIT	10.7 (35)	STEEL	157
DAVIT	13.7 (45)	STEEL	219
DAVIT	16.8 (55)	STEEL	330
DAVIT	19.8 (65)	STEEL	428
POST TOP	4.7 (15)	STEEL	53
POST TOP	6.1 (20)	STEEL	68
STRAIGHT SHAFT	7.7 (25)	STEEL	90
STRAIGHT SHAFT	9.1 (30)	STEEL	113
STRAIGHT SHAFT	10.7 (35)	STEEL	172
STRAIGHT SHAFT	13.7 (45)	STEEL	220
STRAIGHT SHAFT	16.8 (55)	STEEL	388
STRAIGHT SHAFT	19.8 (65)	STEEL	557

* ALL POLES ARE BASE MOUNTED EXCEPT CONCRETE.

** WEIGHTS DO NOT INCLUDE ARMS OR LUMINAIRES.

*** WEIGHTS GATHERED FROM MANUFACTURER'S DRAWING.

BASES

TYPE	WEIGHT kg (±10%)
179	605
197	605
206	605
243	970
418	2151

APPROVED	REVISIONS	MANITOBA HYDRO DISTRIBUTION STANDARDS	
ORIGINAL DRAWING SEALED BY D.R. ORR 16-01-14		RIGGING WEIGHTS OF STREET LIGHT COMPONENTS	
	18-04 1 UPDATED TABLES		
DRAWN C.A.	CHECKED J.R.	DATE 16-01	CD 300-18
		SHT 0001 OF 1	REV 01

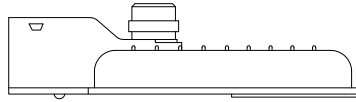

LED ROADWAY LUMINAIRE

LED ROADWAY LUMINAIRES			
LUMINAIRE WATTAGE (NOMINAL)	REPLACES (HPS)	CIIC	
		GREY	BLACK
40 W LED	70 W HPS	05 15 44	05 15 71
60 W LED	100 W HPS	05 15 45	05 15 73
90 W LED	150 W HPS	05 15 47	05 15 74
150 W LED	250 W HPS	05 15 48	05 15 75
240 W LED	400 W HPS	05 15 49	05 15 76

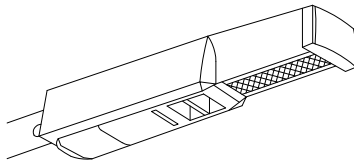

LED LANE LUMINAIRE

LED LANE LUMINAIRES		
LUMINAIRE WATTAGE (NOMINAL)	REPLACES (HPS)	CIIC
50 W LED	70 W HPS	05 15 50

LED LANE LUMINAIRES ARE AVAILABLE WITH GREY COATING ONLY.

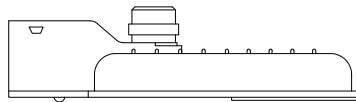

LED DUSK-TO-DAWN LUMINAIRE

LED DUSK-TO-DAWN (AREA) LUMINAIRES		
LUMINAIRE WATTAGE (NOMINAL)	REPLACES (HPS)	CIIC
60 W LED	100 W HPS	05 15 51
90 W LED	150 W HPS	05 15 52

LED DUSK-TO-DAWN LUMINAIRES ARE AVAILABLE WITH GREY COATING ONLY.

- ALL LED LUMINAIRES AUTOMATICALLY ADJUST FOR EITHER A 120V OR 240V SUPPLY.
- ALL LED LUMINAIRES COME WITH A PHOTOCCELL RECEPTACLE.

APPROVED		REVISIONS		MANITOBA HYDRO DISTRIBUTION STANDARDS	
ORIGINAL DRAWING SEALED BY D.R. ORR 15-02-11		16-12 1 REVISED NOTES		STANDARD LED LUMINAIRES	
		DATE 15-02		CD 300-24	
				SHT 0001 OF 2	
				REV 01	

TRENCH AND PLOW-IN LOCATION

GENERALLY, THE TRENCH LOCATION WILL DICTATE THE LOCATION OF THE LIGHT STANDARDS. CONTACT SHALL BE MADE WITH THE GOVERNING MUNICIPAL AUTHORITY TO DETERMINE THEIR SET BACK REQUIREMENTS. CONTACT SHALL ALSO BE MADE WITH THE CITY OF WINNIPEG UNDERGROUND STRUCTURES OR THE INDIVIDUAL UTILITIES OUTSIDE WINNIPEG TO DETERMINE THE EXISTENCE AND EXACT LOCATION OF OTHER UTILITIES PLANT. THIS INFORMATION WILL BE INCLUDED ON THE WORK ORDER PLANS.

DEPTH OF BURIAL

THE CABLE SHALL BE BURIED BELOW THE SURFACE OF THE EARTH A MINIMUM OF 600mm IN SODDED AREAS AND 1000mm IN ROADWAYS.

TRENCH DETAILS

TYPICAL TRENCH DETAILS FOR SODDED AREAS ARE SHOWN BELOW, FOR TRENCH DETAILS UNDER ROADWAYS REFER TO DRAWING CD205-14. SEE NOTES ON SHEET 2 of 2.

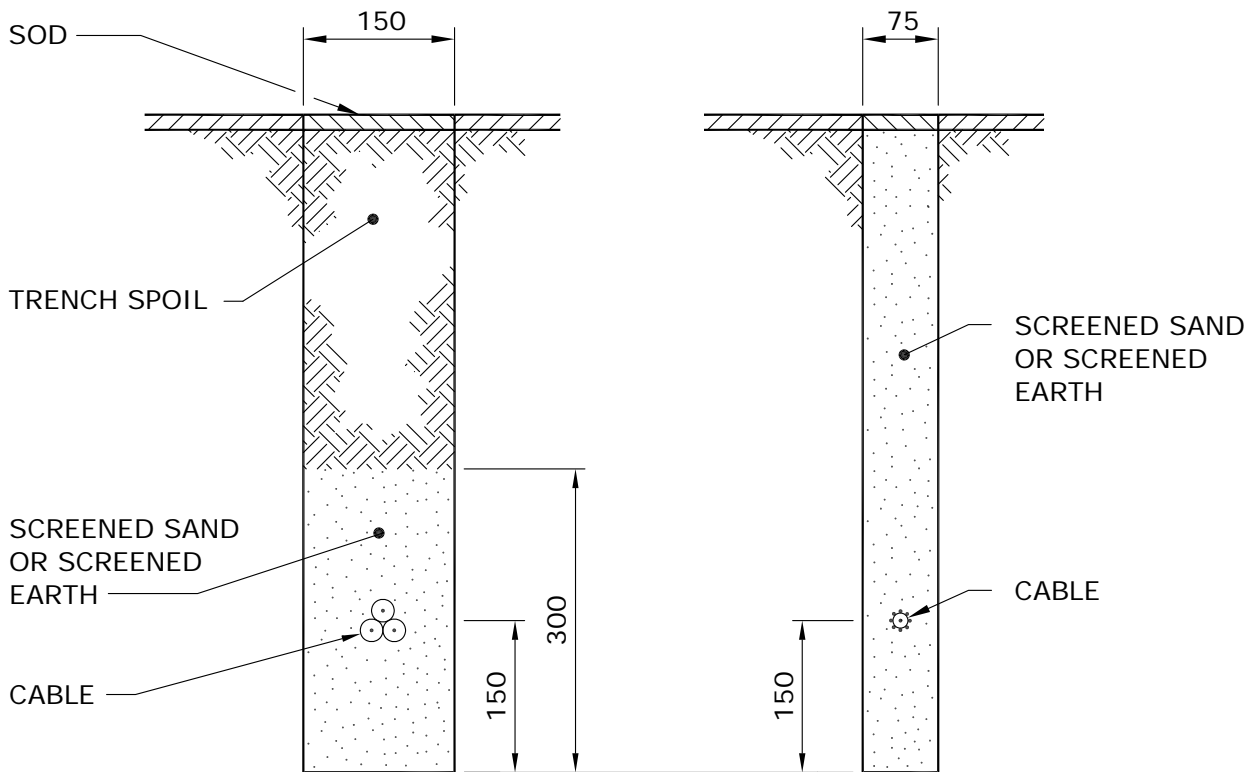

NOTE: DIMENSIONS SHOWN ARE MILLIMETRES.

APPROVED		REVISIONS		MANITOBA HYDRO DISTRIBUTION STANDARDS	
ORIGINAL DRAWING SEALED BY E.H. WIEBE 89-04-28	96-01	3	ROADWAY DEPTH ADDED	PLOWING AND TRENCHING DETAILS FOR UNDERGROUND STREET LIGHT CIRCUITS	
	95-09	2	BURIAL DEPTH NOTE ADDED		
	94-04	1	COMBINED WITH DWG. CD305-2		
DRAWN W.B./CAD	CHECKED	DATE 88-07	CD 305-1		SHT 0001 OF 2
					REV 03

NOTES:

1. FOR TYPICAL TRENCH DETAIL INSTALLATION UNDER ROADWAYS, REFER TO DRAWING CD205-14.
2. THESE ARE ALTERNATIVE TRENCH WIDTHS. A 75mm TRENCH IS PREFERABLE WHERE THE GROUND IS FIRM AND A CLEAN CUT CAN BE MADE. A 150mm TRENCH IS PREFERABLE WHERE THE GROUND IS TOO LOOSE TO MAINTAIN A FIRM TRENCH WALL.
3. THE CABLES INDICATED IN THE VIEWS CAN BE USED IN EITHER TRENCH.
4. THE 75mm TRENCH SHALL BE BACKFILLED WITH SCREENED SAND OR SCREENED EARTH.
5. THE 150mm TRENCH SHALL BE BACKFILLED WITH THE TRENCH SPOIL IF IT IS FREE FROM ROCKS OR DEBRIS. IF THE TRENCH SPOIL CONTAINS ROCKS OR DEBRIS, SCREENED SAND OR SCREENED EARTH SHALL BE INSTALLED AS SHOWN.

APPROVED		REVISIONS		MANITOBA HYDRO DISTRIBUTION STANDARDS		
ORIGINAL DRAWING SEALED BY E.H. WIEBE 89-04-28				PLOWING AND TRENCHING DETAILS FOR UNDERGROUND STREET LIGHT CIRCUITS		
		96-01	2			NOTES REVISED
		94-04	1			COMBINED WITH DWG. CD305-2
DRAWN W.B./CAD	CHECKED	DATE 88-07	CD 305-1		SHT 0002 OF 2	
					REV 02	

1. **GENERAL**

PLOWED-IN CABLES SHALL BE PULLED TO 1m ABOVE GRADE AT EACH STREET LIGHT STANDARD LOCATION. THE CABLE DEPTH SHALL BE MAINTAINED AT THE 600mm PLOW DEPTH AS CLOSE AS POSSIBLE TO THE STREET LIGHT STANDARD LOCATION BEFORE RAISING THE PLOW. THE PLOW SHALL BE RETURNED TO THE 600mm PLOW DEPTH AS CLOSE AS POSSIBLE TO THE CENTRE LINE OF THE STREET LIGHT STANDARD LOCATION.

CABLES LAID IN TRENCHES SHALL HAVE SUFFICIENT SLACK TO ALLOW FOR FUTURE MOVEMENT OR SETTLING OF THE TRENCH FLOOR. CABLES SHALL PROJECT 1m ABOVE GRADE AT EACH LOCATION.

2. **USE OF POLYETHYLENE PIPE**

2.1 WHERE CABLES ARE INSTALLED UNDER EXISTING PAVEMENT, POLYETHYLENE PIPE SHALL BE INSTALLED TO PROTECT THE CABLES IF THE HOLE IS AUGERED OR PUSHED THROUGH MATERIAL CONTAINING ROCKS, STONES, OR DEBRIS.

2.2 AT THE JUNCTION OF THE MAIN TRENCH AND THE STREET OR DRIVEWAY CROSSING, THE BOTTOM OF THE TRENCH SHALL BE BACKFILLED AND TAMPED TO THE LEVEL OF THE POLYETHYLENE PIPES TO PREVENT SHARP BENDS IN THE CABLE AND TRAPPING OF WATER IN THE PIPE.

3. **SPLICES - UNDERGROUND CABLES**

UNDERGROUND STREET LIGHT CABLES (i.e. #4 ALUMINUM CONCENTRIC NEUTRAL CABLE AND 1/0 TRIPLEXED CABLE) ARE TO BE SPLICED USING AN APPROPRIATE COMPRESSION SLEEVE (SEE DRAWING CD210-21) AND THE SPLICE IS TO BE INSULATED USING ONE OF THE FOLLOWING METHODS:

- 1) RAYCHEM RAYVOLVE SPLICE
- 2) PRE-STRETCHED INSULATING TUBING SPLICE
- 3) HEAT SHRINK INSULATING TUBING SPLICE
- 4) TAPED SPLICE

FOR COMPLETE INSTRUCTIONS REGARDING THE ABOVE SPLICES, REFER TO DRAWING CD215-12.

APPROVED		REVISIONS		MANITOBA HYDRO DISTRIBUTION STANDARDS			
ORIGINAL DRAWING SEALED BY E.H. WIEBE 89-04-28		94-04 1		DWG. REFERENCE CHANGED			
DRAWN W.B./CAD	CHECKED W.C.	DATE 88-07	CD 310-1		SHT	REV	
					0001 OF 2	01	

4. **CABLE END CAPS**

STREET LIGHT CABLES WHICH ARE NOT GOING TO BE SPLICED OR TERMINATED IMMEDIATELY FOLLOWING INSTALLATION SHALL BE CUT SQUARE AND SEALED WITH AN END CAP. REFER TO DRAWING CD215-21 FOR DETAILS.

5. **GROUNDING OF STREET LIGHT STANDARDS**

5.1 ALL STREET LIGHT STANDARDS SHALL BE GROUNDED BY CONNECTING THE NEUTRAL TO THE GROUND STUD INSIDE THE STANDARD. REFER TO DRAWING CD310-4 FOR DETAILS.

5.2 A GROUND ROD SHALL BE INSTALLED AND CONNECTED TO THE GROUND STUD AT THE LAST STANDARD ON THE STREET LIGHT CIRCUIT.

APPROVED		REVISIONS		MANITOBA HYDRO DISTRIBUTION STANDARDS	
ORIGINAL DRAWING SEALED BY E.H. WIEBE 89-04-28		94-04 1 DWG. REFERENCE CHANGED		INSTALLATION OF STREET LIGHT CABLES	
W.B./CAD		W.C.		DATE	
				88-07	
CD 310-1				SHT	
				0002 OF 2	
				REV	
				01	

RAYCHEM GELCAP CIIC# 04-29-36

GENERAL INSTRUCTIONS:

1. REMOVE 16mm (5/8") OF INSULATION AND CLEAN EXPOSED ENDS.

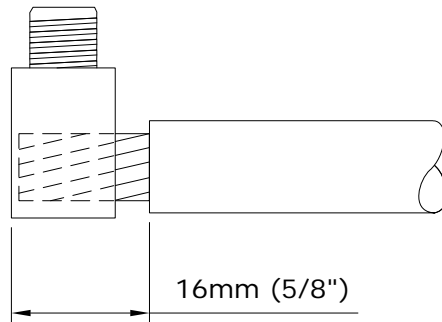

2. INSERT CONDUCTORS INTO CORRECT HOLES AND TORQUE AS SHOWN:

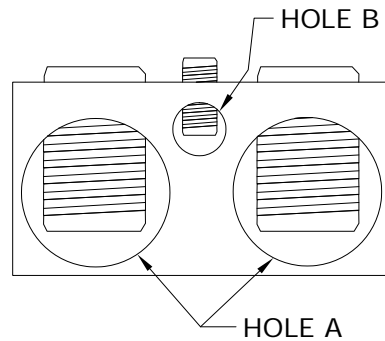

HOLE A		HOLE B	
WIRE RANGE	RECOMMENDED TORQUE VALUES	WIRE RANGE	RECOMMENDED TORQUE VALUES
#14 - 2/0 • STREET LIGHT CIRCUIT CABLES • GROUNDING CONNECTIONS • CONCENTRIC NEUTRAL • FUSE HOLDER WIRE	14 - 20 N-m (120 - 180 in-lbs)	#14 - #6 • LAMP LEADS	14 - 17 N-m (120 - 150 in-lbs)

APPROVED	REVISIONS		MANITOBA HYDRO DISTRIBUTION STANDARDS		
ORIGINAL DRAWING SEALED BY J.J.D. RINGASH 18-03-05			RAYCHEM GELCAP SPLICE		
DRAWN	CHECKED	DATE	CD 310-3	SHT	REV
C.A.	L.D.	17-11		0001 OF 3	00

- INSTALL CLAMP ON CAP. ENSURE THE TWO PINS ON THE BOTTOM EDGE OF THE CLAMP MATE WITH THE HOLES OF THE CAP AS SHOWN IN FIGURE 1a BELOW.

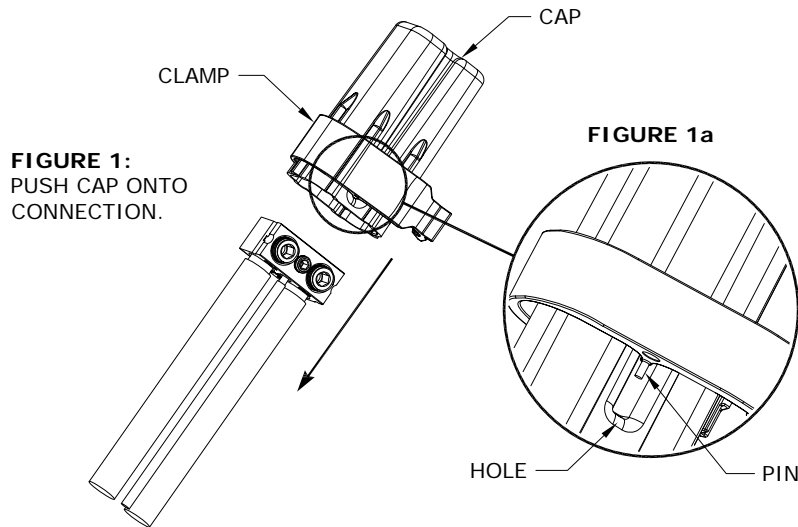

- INSTALL CAP BY HOLDING ALL WIRES AND PUSHING THE CAP OVER THE CONNECTION ASSEMBLY UNTIL IT GOES NO FURTHER AS SHOWN IN FIGURE 1 ABOVE.
- SNAP CLAMP CLOSED. IF NECESSARY, USE PLIERS TO SNAP CLAMP CLOSED AS SHOWN IN FIGURE 2 BELOW.

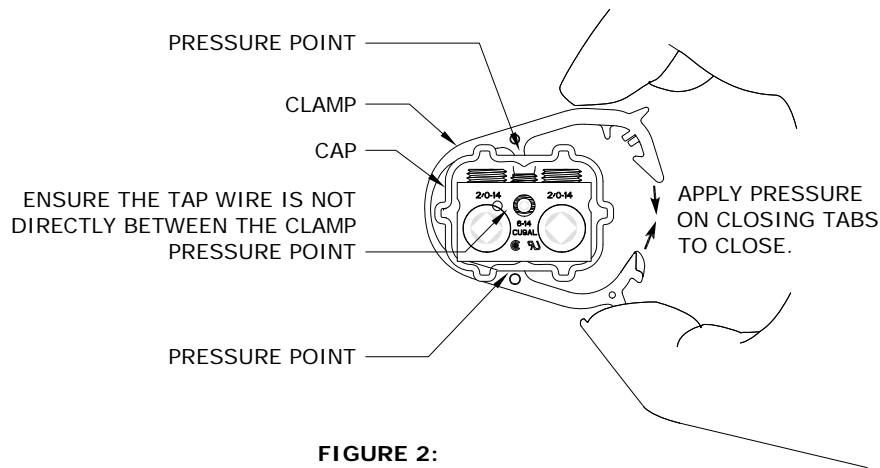
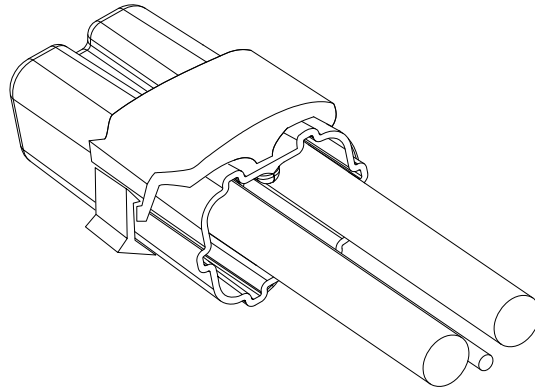

FIGURE 2:
CLAMP PRESSURE POINTS SHOULD FIT INTO OPPOSING GROOVES OF CAP AND APPLY PRESSURE BETWEEN CABLES. SNAP CLAMP CLOSED.

APPROVED		REVISIONS		MANITOBA HYDRO DISTRIBUTION STANDARDS	
ORIGINAL DRAWING SEALED BY J.J.D. RINGASH 18-03-05				RAYCHEM GELCAP SPLICE	
DRAWN C.A.	CHECKED L.D.	DATE 17-11	CD 310-3		
			SHT 0002 OF 3		REV 00

6. INSPECT THE INSTALLATION BY GENTLY PULLING ON THE CAP ENSURING IT IS LOCKED IN PLACE AND COVERS CONNECTOR AND BARE CONDUCTOR. THERE SHOULD BE NO EXPOSED METAL. ENSURE TAP CABLE IS NOT CAUGHT BETWEEN PRESSURE POINTS OF CLAMP. INSTALLATION IS COMPLETE.



7. TO REMOVE, INSERT SCREWDRIVER BETWEEN THE CLOSING TABS AND TWIST TO OPEN THE CLAMP. REMOVE CAP SLOWLY FROM CONNECTION ALLOWING GEL TO REMAIN IN CAP.

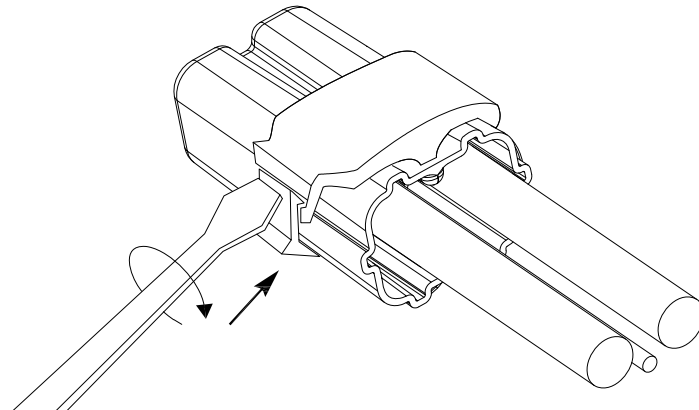

APPROVED		REVISIONS		MANITOBA HYDRO DISTRIBUTION STANDARDS	
ORIGINAL DRAWING SEALED BY J.J.D. RINGASH 18-03-05				RAYCHEM GELCAP SPLICE	
DRAWN C.A.	CHECKED L.D.	DATE 17-11	CD 310-3		
					SHT 0003 OF 3

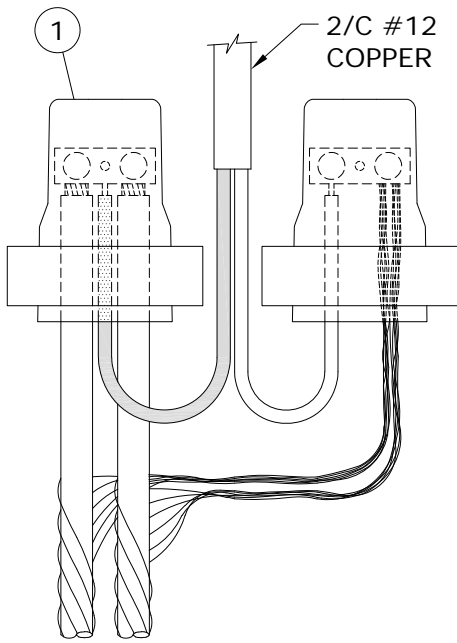

**No. 4 ALUMINUM C/N CABLE
(TYPICAL FEED THROUGH)**

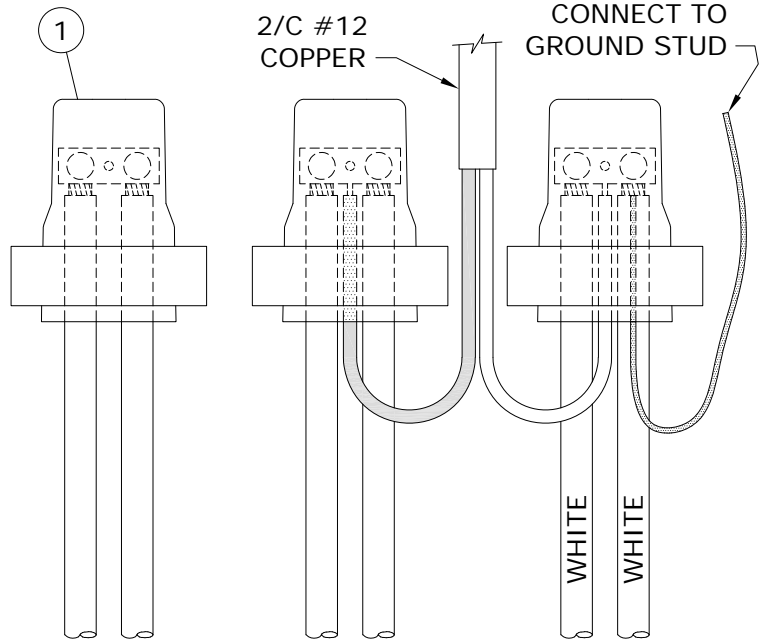

**1/0 ALUMINUM TRIPLEX CABLE
(TYPICAL FEED THROUGH)**

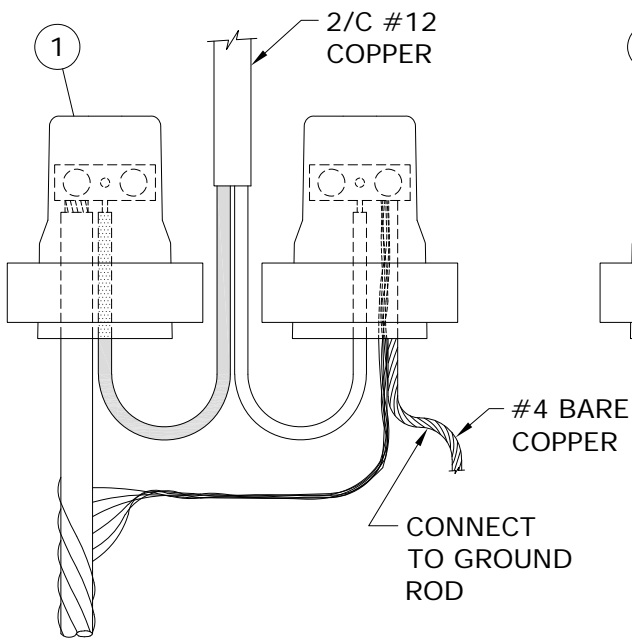

**No. 4 ALUMINUM C/N CABLE
(TYPICAL END OF CIRCUIT)**

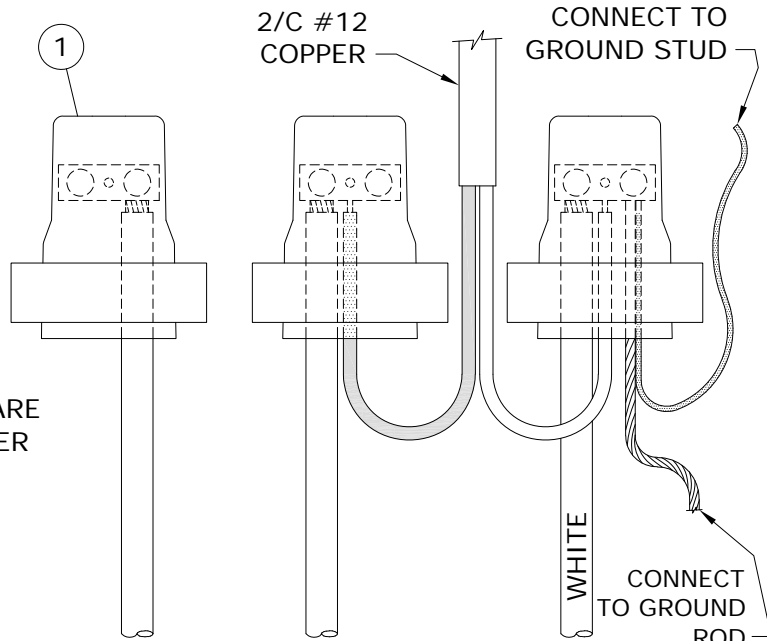

**1/0 ALUMINUM TRIPLEX CABLE
(TYPICAL END OF CABLE)**

SUPERCEDES ORIGINAL SEALED BY E. WIEBE ON 89-04-28

APPROVED		REVISIONS		MANITOBA HYDRO DISTRIBUTION STANDARDS	
ORIGINAL DRAWING SEALED BY J.J.D. RINGASH 18-05-11	18-04	2	ADDED SHT 3 & 4, MOVED PREVIOUS INFO FROM SHT1 TO SHT3, ADDED NEW GELCAP, DWG, REVISED TITLE, RESEALED	CONNECTION DETAIL IN STREET LIGHT STANDARD	
	94-04	1	CONN. REVISED DUE TO INSUL. NEUTRAL		
DRAWN C.A.	CHECKED L.D.	DATE 18-04		CD 310-4	

BILL OF MATERIAL			
ITEM No.	DESCRIPTION	STORES CODE No.	
		FOR USE WITH #4 AL. C/N	FOR USE WITH 1/0 AL. TRIPLEX
1	GEL CAP	04-29-36 (2 REQUIRED)	04-29-36 (3 REQUIRED)

NOTES:

1. LEAVE SUFFICIENT SLACK ON CONDUCTORS TO ALLOW REMOVAL FROM HANDHOLE FOR MAINTENANCE.
2. REFER TO DRAWING CD310-3 FOR GEL CAP INSTALLATION INSTRUCTIONS.

SUPERCEDES ORIGINAL SEALED BY E. WIEBE ON 94-07-03

APPROVED		REVISIONS		MANITOBA HYDRO DISTRIBUTION STANDARDS	
ORIGINAL DRAWING SEALED BY J.J.D. RINGASH 18-05-11		18-04 1 ADDED SHT 3 & 4, MOVED PREVIOUS INFO FROM SHT2 TO SHT4, ADDED NEW BOM WITH GELCAP, REVISED TITLE, RESEALED		CONNECTION DETAIL IN STREET LIGHT STANDARD	
C.A.		L.D.		DATE	
				18-04	
				CD 310-4	
				SHT	
				0002 OF 4	
				REV	
				01	

1-04431-DA-56200-0002

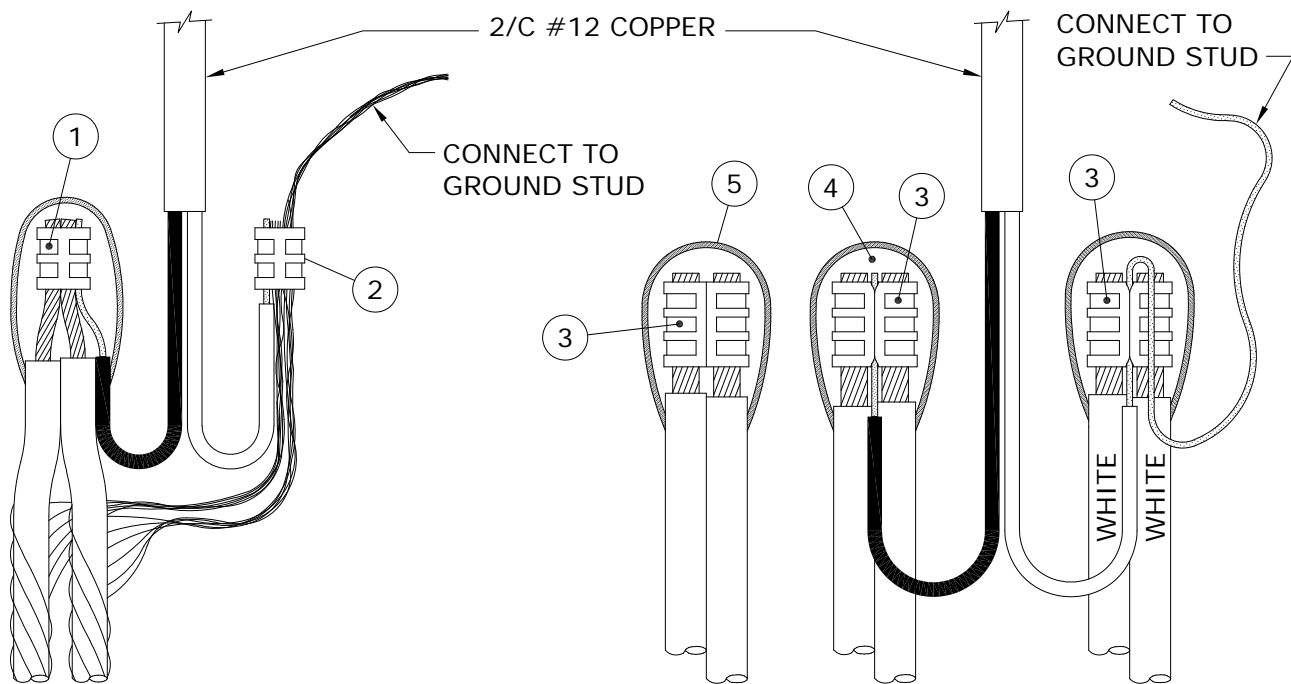

**No. 4 ALUMINUM C/N CABLE
(TYPICAL FEED THROUGH)**

**1/0 ALUMINUM TRIPLEX CABLE
(TYPICAL FEED THROUGH)**

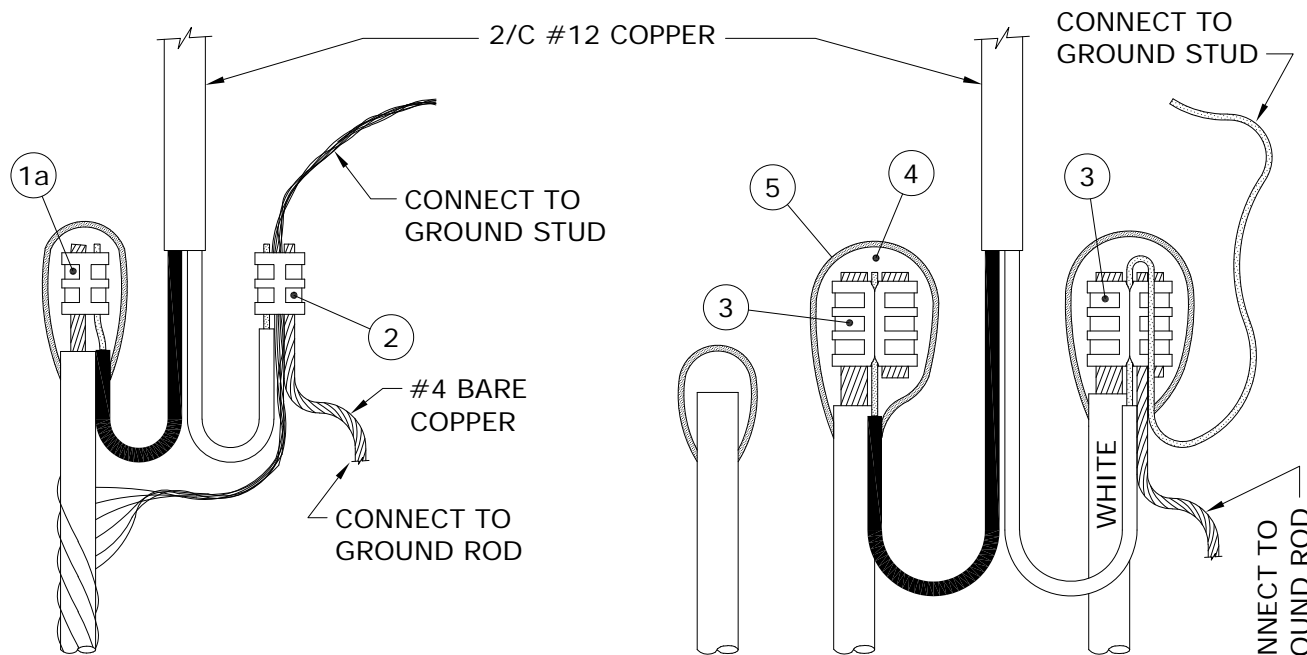

**No. 4 ALUMINUM C/N CABLE
(TYPICAL END OF CIRCUIT)**

**1/0 ALUMINUM TRIPLEX CABLE
(TYPICAL END OF CIRCUIT)**

APPROVED		REVISIONS		MANITOBA HYDRO DISTRIBUTION STANDARDS			
ORIGINAL DRAWING SEALED BY J.J.D. RINGASH 18-05-11		18-04 0 MOVED FROM SHEET 1		CONNECTION DETAIL IN STREET LIGHT STANDARD			
						DRAWN C.A.	
CD 310-4				SHT		REV	
				0003 OF 4		00	

BILL OF MATERIAL

ITEM No.	DESCRIPTION	STORES CODE No.		QUANTITY
		FOR USE WITH #4 AL. C/N	FOR USE WITH 1/0 AL. TRIPLEX	
1	'C' TYPE AL. COMPRESSION TAP	74-41-30	---	1
1a	'H' TYPE AL. COMPRESSION TAP	74-40-10	---	1 *
2	'C' TYPE CU. COMPRESSION TAP	74-40-90	---	1
3	'H' TYPE AL. COMPRESSION TAP	---	74-40-60	3 **
4	TAPE, SELF-AMALGAMATING EPR	78-55-23	78-55-23	1/4 ROLL
5	TAPE, COLD WEATHER VINYL	78-55-98	78-55-98	1/4 ROLL

* FOR END OF CIRCUIT WHEN USING ONLY ONE CABLE.

** AT END OF CIRCUIT, QUANTITY MAY BE LESS THAN SHOWN.

NOTES:

- LEAVE SUFFICIENT SLACK ON CONDUCTORS TO ALLOW REMOVAL FROM HANDHOLE FOR MAINTENANCE.**
- FOR PROPER TAPING PROCEDURE, REFER TO DRAWING CD215-12.

APPROVED		REVISIONS		MANITOBA HYDRO DISTRIBUTION STANDARDS			
ORIGINAL DRAWING SEALED BY J.J.D. RINGASH 18-05-11		18-04 0		<p align="center">CONNECTION DETAIL IN STREET LIGHT STANDARD</p>			
DRAWN C.A.	CHECKED L.D.	DATE 18-04		<p align="center">CD 310-4</p>		SHT	REV
						0004 OF 4	00

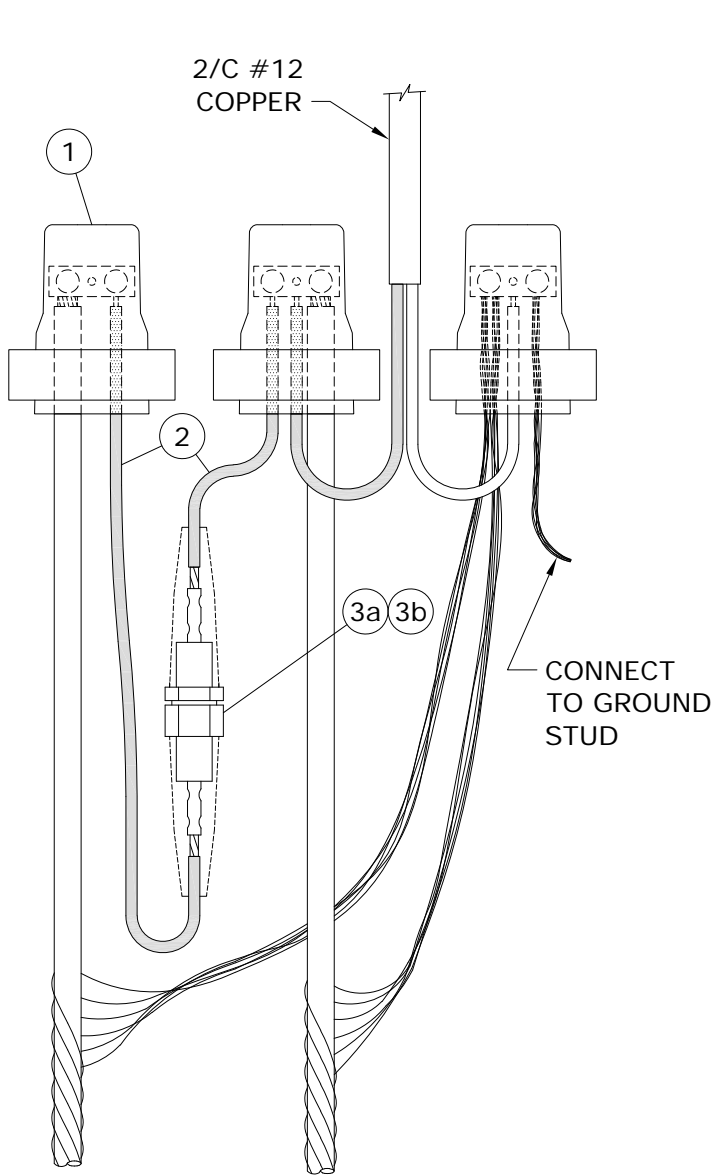

No. 4 ALUMINUM C/N CABLE

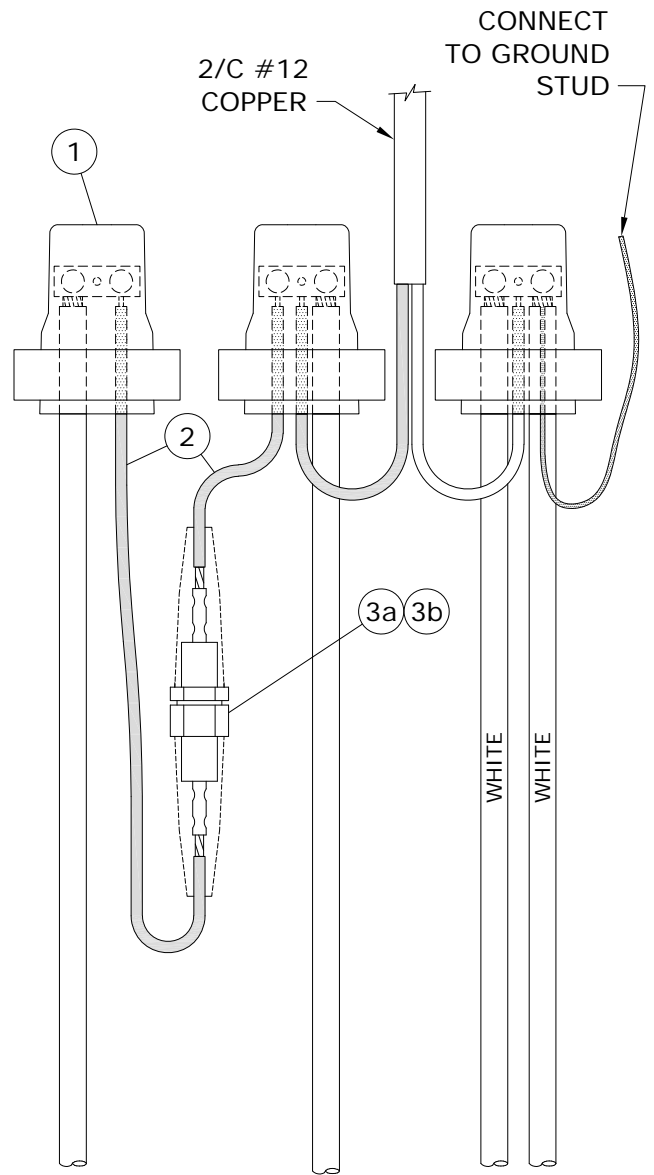

1/0 ALUMINUM TRIPLEX CABLE

SUPERCEDES ORIGINAL SEALED BY E. WIEBE ON 89-04-28

APPROVED		REVISIONS		MANITOBA HYDRO DISTRIBUTION STANDARDS	
ORIGINAL DRAWING SEALED BY J.J.D. RINGASH 18-03-05	17-11	2	ADDED SHT 3 & 4, MOVED PREVIOUS INFO FROM SHT1 TO SHT3, ADDED NEW GELCAP DWG, RESEALED	STREET LIGHT CIRCUIT PROTECTED BY 30A FUSE IN STREET LIGHT STANDARD	
	94-04	1	CONN. REVISED DUE TO INSUL. NEUTRAL		
DRAWN C.A.	CHECKED L.D.	DATE 17-11		CD 310-9	

BILL OF MATERIAL

ITEM No.	DESCRIPTION	STORES CODE No.		QUANTITY
		FOR USE WITH #4 AL. C/N	FOR USE WITH 1/0 AL. TRIPLEX	
1	GEL CAP	04-29-36	04-29-36	3
2	WIRE, # 8 CU., 600V, PVC	93-10-08	93-10-08	1m
3a	FUSEHOLDER, 15/30A C/W BOOTS	31-91-30	31-91-30	1
3b	FUSE, 30A	31-14-30	31-14-30	1

NOTES:

- 1. LEAVE SUFFICIENT SLACK ON CONDUCTORS AND FUSE HOLDER TO ALLOW REMOVAL FROM HANDHOLE FOR FUSE REPLACEMENT AND MAINTENANCE.**
2. FOR SPLICING FEED THROUGH HOT LEG, REFER TO DRAWING CD310-4.
3. FOR GEL CAP INSTALLATION INSTRUCTIONS, REFER TO DRAWING CD310-3.

SUPERCEDES ORIGINAL SEALED BY E. WIEBE ON 94-07-03

APPROVED		REVISIONS		MANITOBA HYDRO DISTRIBUTION STANDARDS	
ORIGINAL DRAWING SEALED BY J.J.D. RINGASH 18-03-05		17-11 1 ADDED SHT 3 & 4, MOVED PREVIOUS INFO FROM SHT2 TO SHT4, ADDED NEW BOM WITH GELCAP, RESEALED		<p align="center">STREET LIGHT CIRCUIT PROTECTED BY 30A FUSE IN STREET LIGHT STANDARD</p>	
				CD 310-9	

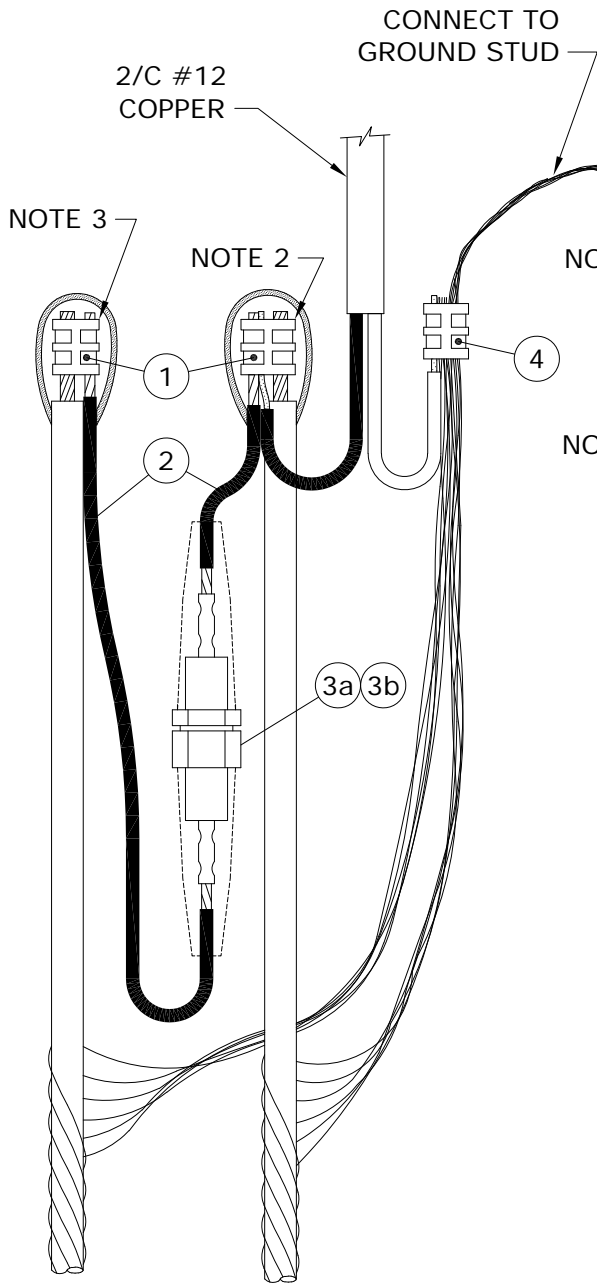

No. 4 ALUMINUM C/N CABLE

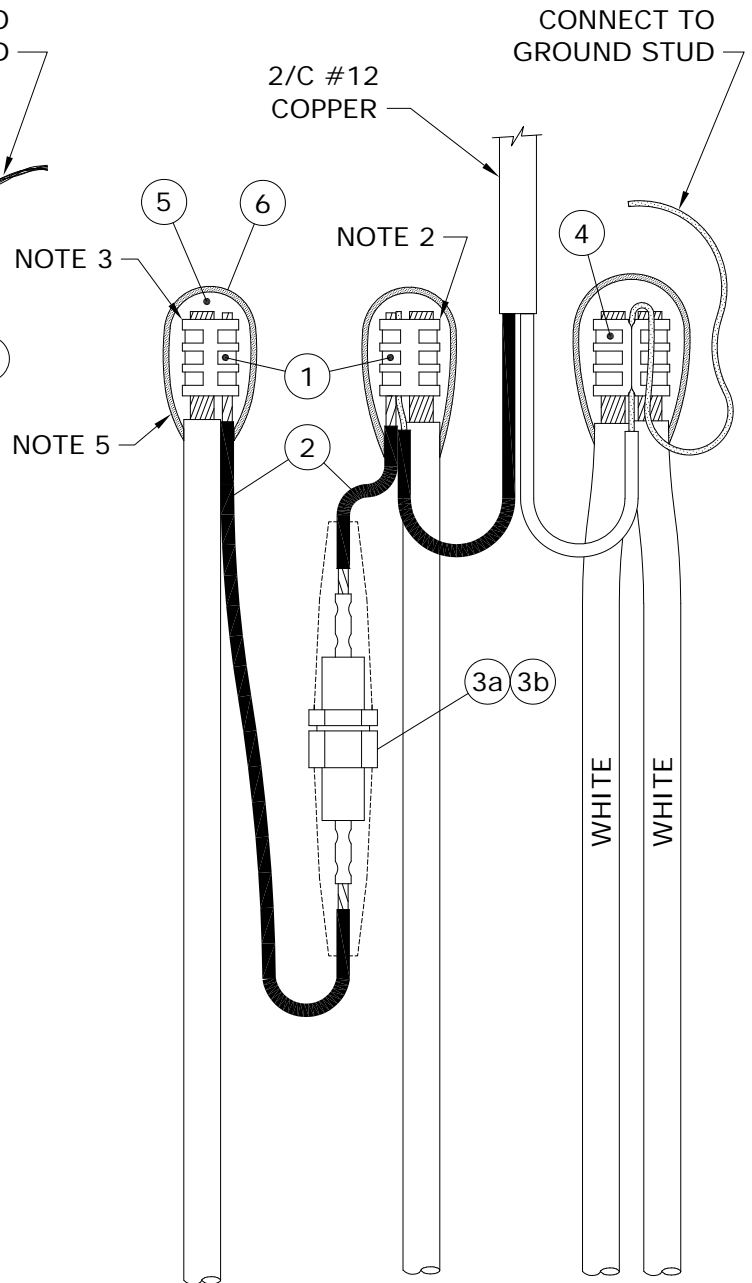

1/0 ALUMINUM TRIPLEX CABLE

APPROVED	REVISIONS		MANITOBA HYDRO DISTRIBUTION STANDARDS	
ORIGINAL DRAWING SEALED BY J.J.D. RINGASH 18-03-05			STREET LIGHT CIRCUIT PROTECTED BY 30A FUSE IN STREET LIGHT STANDARD	
17-11	0	MOVED FROM SHEET 1		
DRAWN C.A.	CHECKED L.D.	DATE 17-11	CD 310-9	

BILL OF MATERIAL

ITEM No.	DESCRIPTION	STORES CODE No.		QUANTITY
		FOR USE WITH #4 AL. C/N	FOR USE WITH 1/0 AL. TRIPLEX	
1	'H' TYPE COMPRESSION TAP	74-40-10	74-40-30	2
2	WIRE, # 8 CU., 600V, PVC	93-10-08	93-10-08	1m
3a	FUSEHOLDER, 15/30A C/W BOOTS	31-91-30	31-91-30	1
3b	FUSE, 30A	31-14-30	31-14-30	1
4	'C' TYPE COMPRESSION TAP	74-40-90	---	1
	'H' TYPE COMPRESSION TAP	---	74-40-60	1 *
5	TAPE, SELF-AMALGAMATING EPR	78-55-23	78-55-23	1/4 ROLL
6	TAPE, COLD WEATHER VINYL	78-55-98	78-55-98	1/4 ROLL

* WHEN USING 1/0 ALUMINUM TRIPLEX 1 ADDITIONAL 'H' TYPE COMPRESSION TAP (S.C.# 74 40 60) IS REQUIRED TO CONNECT SECOND (FEED THROUGH) HOT LEG.

NOTES:

- LEAVE SUFFICIENT SLACK ON CONDUCTORS AND FUSE HOLDER TO ALLOW REMOVAL FROM HANDHOLE FOR FUSE REPLACEMENT AND MAINTENANCE.**
- INSERT #12 COPPER AND #8 COPPER IN SMALL GROOVE.
- INSERT DOUBLE THICKNESS OF #8 COPPER IN SMALL GROOVE.
- FOR SPLICING FEED THROUGH HOT LEG, REFER TO DRAWING CD310-4.
- FOR PROPER TAPING PROCEDURE, REFER TO DRAWING CD215-12.

APPROVED		REVISIONS		MANITOBA HYDRO DISTRIBUTION STANDARDS			
ORIGINAL DRAWING SEALED BY J.J.D. RINGASH 18-03-05		17-11 0		<p align="center">STREET LIGHT CIRCUIT PROTECTED BY 30A FUSE IN STREET LIGHT STANDARD</p>			
DRAWN C.A.	CHECKED L.D.	DATE 17-11		CD 310-9		SHT	REV
						0004 OF 4	00

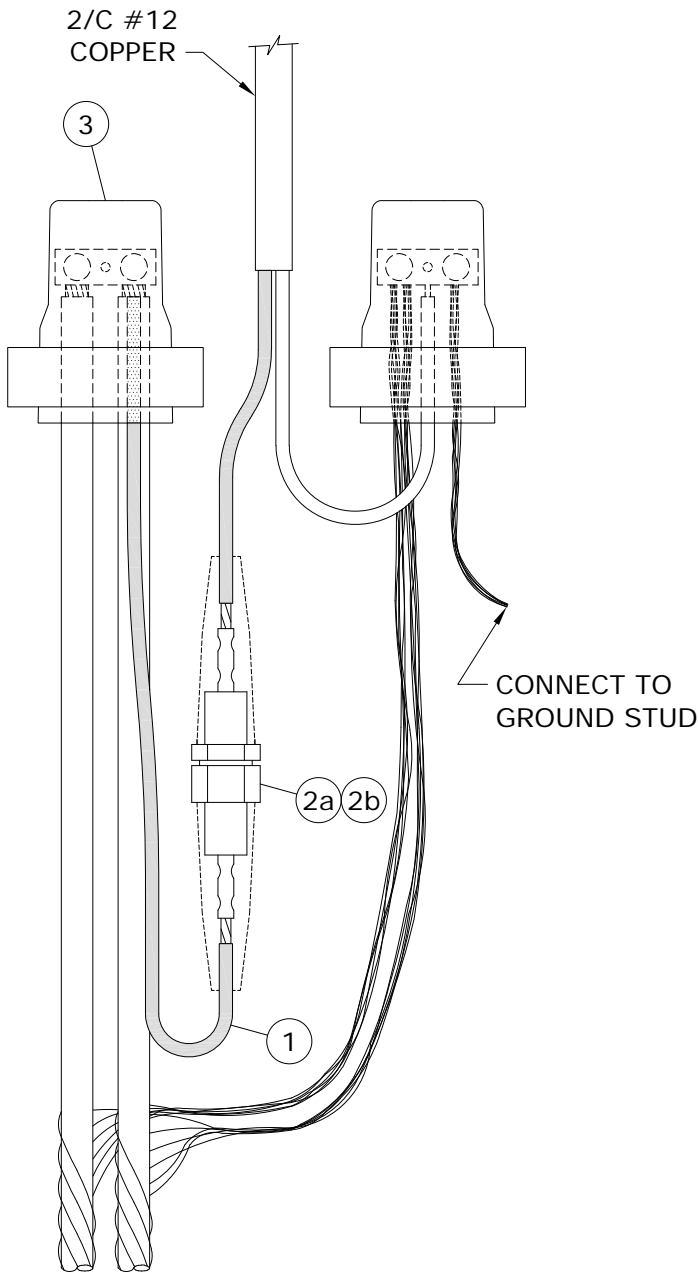

No. 4 ALUMINUM C/N CABLE

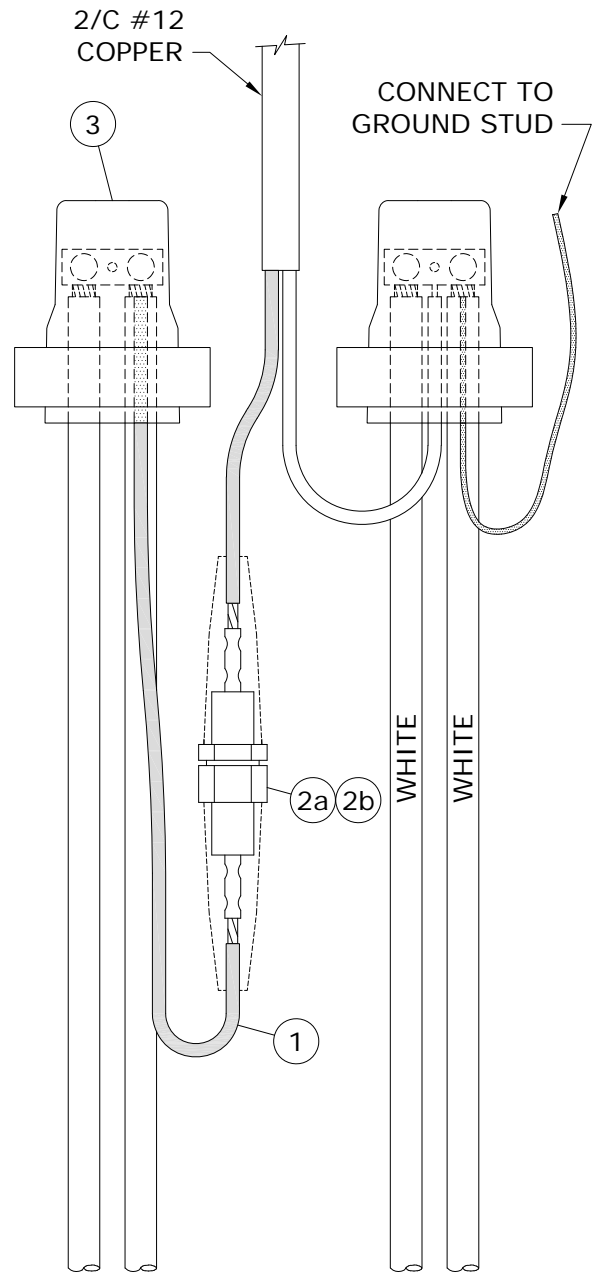

1/0 ALUMINUM TRIPLEX CABLE

NOTE:

RECOMMENDED FOR PROTECTING LUMINAIRES WHICH ARE TO BE MOUNTED ON STREET LIGHT POLES 16.8m AND HIGHER.

SUPERCEDES ORIGINAL SEALED BY E. WIEBE ON 89-04-28

APPROVED		REVISIONS		MANITOBA HYDRO DISTRIBUTION STANDARDS	
ORIGINAL DRAWING SEALED BY J.J.D. RINGASH 18-05-11	18-04	3	ADDED SHT 3 & 4, MOVED PREVIOUS INFO FROM SHT1 TO SHT3, ADDED NEW GELCAP, DWG, RESEALED	INDIVIDUAL LUMINAIRE PROTECTED BY 15A FUSE IN STREET LIGHT STANDARD	
	95-01	2	NOTE ADDED		
DRAWN C.A.	CHECKED L.D.	DATE 18-04		CD 310-10	

BILL OF MATERIAL

ITEM No.	DESCRIPTION	STORES CODE No.		QUANTITY
		FOR USE WITH #4 AL. C/N	FOR USE WITH 1/0 AL. TRIPLEX	
1	2/C #12 COPPER	93-52-12	93-52-12	1m
2a	FUSEHOLDER, 15/30A C/W BOOTS	31-91-30	31-91-30	1
2b	FUSE, STREET LIGHT, 15A	31-14-15	31-14-15	1
3	GEL CAP	04-29-36	04-29-36	2

NOTES:

- 1. LEAVE SUFFICIENT SLACK ON CONDUCTORS AND FUSE HOLDER TO ALLOW REMOVAL FROM HANDHOLE FOR FUSE REPLACEMENT AND MAINTENANCE.**
2. FOR SPLICING FEED THROUGH HOT LEG, REFER TO DRAWING CD310-4.
3. FOR END OF CIRCUIT, REFER TO DRAWING CD310-4.
4. FOR GEL CAP INSTALLATION INSTRUCTIONS, REFER TO DRAWING CD310-3.

SUPERCEDES ORIGINAL SEALED BY E. WIEBE ON 94-07-03

APPROVED		REVISIONS		MANITOBA HYDRO DISTRIBUTION STANDARDS	
ORIGINAL DRAWING SEALED BY J.J.D. RINGASH 18-05-11		18-04 1 ADDED SHT 3 & 4, MOVED PREVIOUS INFO FROM SHT2 TO SHT4, ADDED NEW BOM WITH GELCAP, RESEALED		<p align="center">INDIVIDUAL LUMINAIRE PROTECTED BY 15A FUSE IN STREET LIGHT STANDARD</p>	
DRAWN C.A.	CHECKED L.D.	DATE 18-04	SHT 0002 OF 4		REV 01

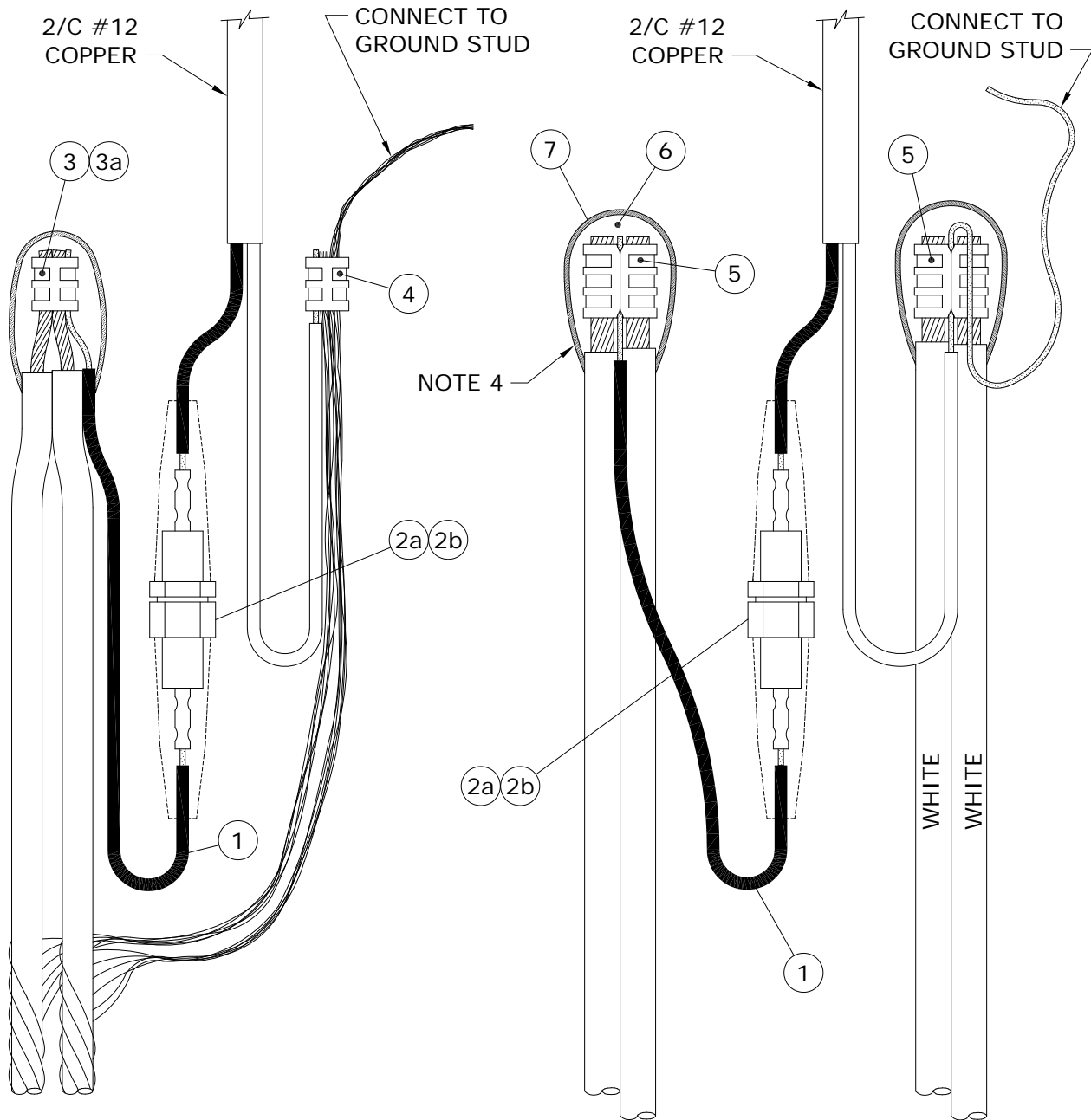

No. 4 ALUMINUM C/N CABLE

1/0 ALUMINUM TRIPLEX CABLE

NOTE:

RECOMMENDED FOR PROTECTING LUMINAIRES WHICH ARE TO BE MOUNTED ON STREET LIGHT POLES 16.8m AND HIGHER.

APPROVED	REVISIONS		MANITOBA HYDRO DISTRIBUTION STANDARDS	
ORIGINAL DRAWING SEALED BY J.J.D. RINGASH 18-05-11			INDIVIDUAL LUMINAIRE PROTECTED BY 15A FUSE IN STREET LIGHT STANDARD	
	18-04	0		
DRAWN C.A.	CHECKED L.D.	DATE 18-04	CD 310-10	

BILL OF MATERIAL

ITEM No.	DESCRIPTION	STORES CODE No.		QUANTITY
		FOR USE WITH #4 AL. C/N	FOR USE WITH 1/0 AL. TRIPLEX	
1	2/C # 12 COPPER	93-52-12	93-52-12	1m
2a	FUSEHOLDER, 15/30A C/W BOOTS	31-91-30	31-91-30	1
2b	FUSE, STREET LIGHT, 15A	31-14-15	31-14-15	1
3	'C' TYPE AL. COMPRESSION TAP	74-41-30	---	1
3a	'H' TYPE AL. COMPRESSION TAP	74-40-10	---	1 *
4	'C' TYPE CU. COMPRESSION TAP	74-40-90	---	1
5	'H' TYPE AL. COMPRESSION TAP	---	74-40-60	3 **
6	TAPE, SELF-AMALGAMATING EPR	78-55-23	78-55-23	1/4 ROLL
7	TAPE, COLD WEATHER VINYL	78-55-98	78-55-98	1/4 ROLL

- * FOR END OF CIRCUIT WHEN USING ONLY ONE CABLE.
- ** AT END OF CIRCUIT, QUANTITY MAY BE LESS THAN SHOWN.

NOTES:

1. LEAVE SUFFICIENT SLACK ON CONDUCTORS AND FUSE HOLDER TO ALLOW REMOVAL FROM HANDHOLE FOR FUSE REPLACEMENT AND MAINTENANCE.
2. FOR SPLICING FEED THROUGH HOT LEG, REFER TO DRAWING CD310-4.
3. FOR END OF CIRCUIT, REFER TO DRAWING CD310-4.
4. FOR PROPER TAPING PROCEDURE, REFER TO DRAWING CD215-12.

APPROVED		REVISIONS		MANITOBA HYDRO DISTRIBUTION STANDARDS			
ORIGINAL DRAWING SEALED BY J.J.D. RINGASH 18-05-11		18-04 0		<p align="center">INDIVIDUAL LUMINAIRE PROTECTED BY 15A FUSE IN STREET LIGHT STANDARD</p>			
DRAWN C.A.	CHECKED L.D.	DATE 18-04		<p align="center">CD 310-10</p>		SHT	REV
						0004 OF 4	00

SUPPLY VOLTAGES

THE SUPPLY VOLTAGE FOR STREET LIGHT CIRCUITS MAY BE PROVIDED BY POLE-MOUNTED DISTRIBUTION TRANSFORMERS OR BY PAD-MOUNTED DISTRIBUTION TRANSFORMERS.

THE MAJORITY OF ROADWAY LUMINAIRES ARE RATED FOR OPERATION ON EITHER 120 VOLT OR 240 VOLT CIRCUITS AND ARE FACTORY WIRED FOR 120 VOLT OPERATION EXCEPT FOR 400 WATT H.P.S. LUMINAIRES WHICH ARE RATED FOR 120/240 VOLT OPERATION BUT ARE FACTORY WIRED FOR 240 VOLT OPERATION.

IN CASES WHERE EXCESSIVE VOLTAGE DROP IN A STREET LIGHTING CIRCUIT IS A PROBLEM, A SUPPLY VOLTAGE OF 240/480 MAY BE USED. A SUPPLY VOLTAGE OF 240/480 CAN BE OBTAINED FROM TWO SINGLE PHASE POLE-MOUNTED DISTRIBUTION TRANSFORMERS CONNECTED AS SHOWN ON DRAWING CD315-2. IF A SINGLE PHASE PAD-MOUNTED DISTRIBUTION TRANSFORMER WITH A 240/480 VOLT SECONDARY IS REQUIRED, THE TRANSFORMER MUST BE ORDERED FROM THE MANUFACTURER (SEE DRAWING CD315-2).

CAUTION:

PRIOR TO CONNECTING LUMINAIRES TO A 240 VOLT SUPPLY CIRCUIT IT IS IMPORTANT TO CHECK THE INTERNAL CONNECTIONS TO THE TERMINAL BLOCK TO ENSURE THAT THE UNIT IS PROPERLY CONNECTED FOR 240 VOLT OPERATION.

APPROVED		REVISIONS		MANITOBA HYDRO DISTRIBUTION STANDARDS	
ORIGINAL DRAWING SEALED BY E.H. WIEBE 89-04-28				SUPPLY VOLTAGES FOR STREET LIGHT CIRCUITS	
DRAWN W.B./CAD	CHECKED W.C.	DATE 88-08	CD 315-1		SHT 0001 OF 1
					REV 00

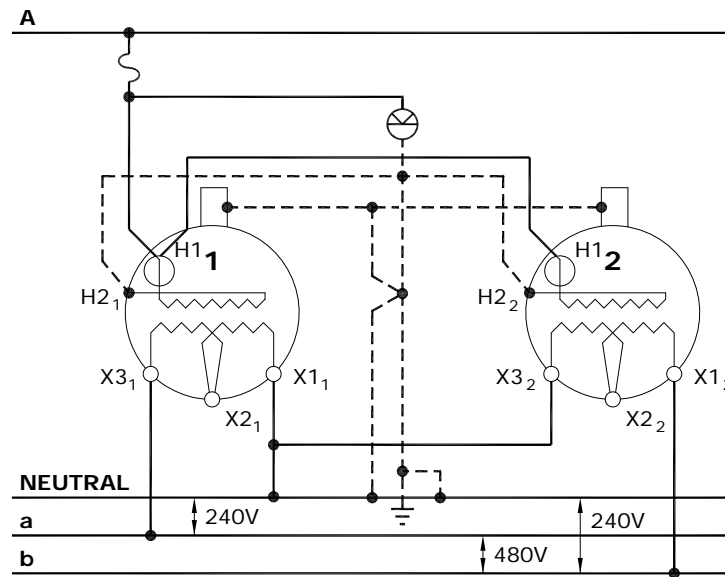

SECONDARY VOLTAGE 240/480V GROUNDED. TWO SINGLE-PHASE POLE-MOUNTED TRANSFORMERS WITH 120/240V SECONDARIES.

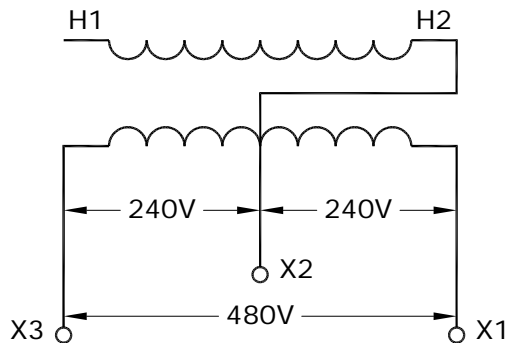

SECONDARY VOLTAGE 240/480V GROUNDED. SINGLE-PHASE PAD-MOUNTED TRANSFORMER AS SUPPLIED BY MANUFACTURER

SAFETY PRECAUTION

1. SINGLE PHASE PAD MOUNTED TRANSFORMERS WITH ABOVE SECONDARY VOLTAGES TO HAVE WARNING SIGN "**CAUTION - 240/480V SECONDARY - SEE NAMEPLATE**", STENCILLED ON THE OUTSIDE OF THE TRANSFORMER NEAR NAMEPLATE.
2. NAMEPLATES OF MODIFIED TRANSFORMERS TO BE REVISED.

PURCHASE OF 240/480 VOLT TRANSFORMER

1. INCLUDE ABOVE WARNING SIGN REQUIREMENT IN PURCHASE DESCRIPTION.

APPROVED	REVISIONS		MANITOBA HYDRO DISTRIBUTION STANDARDS		
ORIGINAL DRAWING SEALED BY E.H. WIEBE 89-04-28			240/480 VOLT SUPPLY FOR STREET LIGHT CIRCUITS		
	13-01	2			REVISED DIAGRAM
	90-04	1			DROPOUT DELETED
DRAWN W.B./CAD	CHECKED L.D./D.O.	DATE 88-08	CD 315-2		
			SHT 0001 OF 1	REV 02	

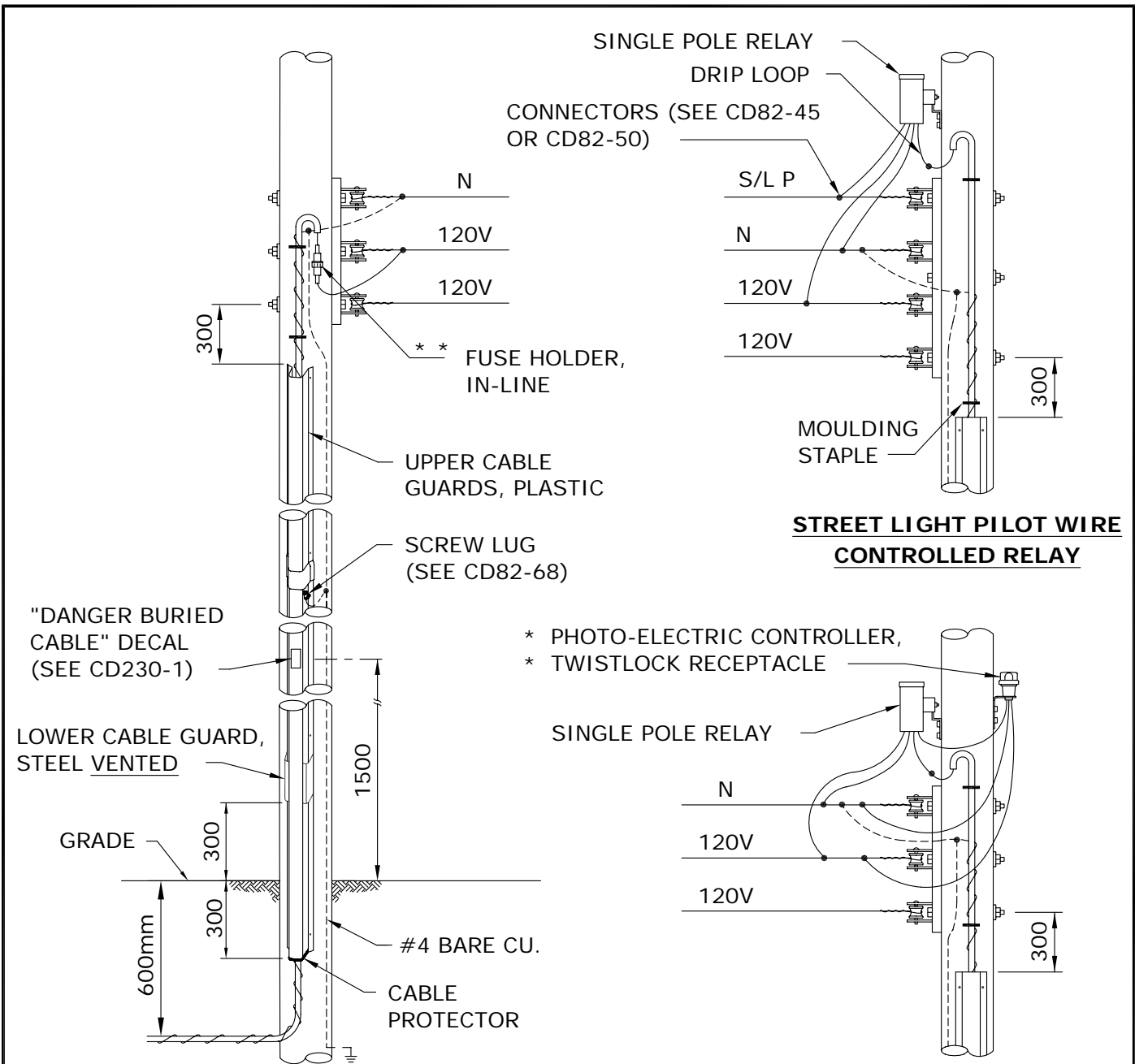

**IN-LINE
FUSE PROTECTED**

**STREET LIGHT PILOT WIRE
CONTROLLED RELAY**

**P.E. CELL
CONTROLLED RELAY**

* * USED WHERE POLY ISN'T USED

* USED WHERE ST./LT. PILOT DOES NOT EXIST

NOTES:

1. REFER TO DRAWING CD200-63 FOR CABLE GUARD INSTALLATION DETAILS.
2. INSTALL A GROUND ROD AT THE LAST POLE ON THE STREET LIGHT CIRCUIT.
3. DIMENSIONS SHOWN ARE MILLIMETRES.

APPROVED	REVISIONS			MANITOBA HYDRO DISTRIBUTION STANDARDS		
ORIGINAL DRAWING SEALED BY E.H. WIEBE 89-04-28	99-08	3	SHOW VENTED CABLE GUARD, SHEET 2 DELETED	DIP POLE FOR UNDERGROUND STREET LIGHTING CIRCUIT		
	94-04	2	DWG. REFERENCE CHANGED			
	92-06	1	NOTE 1			
DRAWN R.L.B./CAD	CHECKED K.C.H.	DATE 88-08	CD 315-5		SHT 0001 OF 1	REV 03

CONTROL METHODS

1. LUMINAIRES CONTROLLED INDIVIDUALLY BY PHOTO-ELECTRIC CELL

THE PREFERRED METHOD FOR PROVIDING ON/OFF CONTROL OF A STREET LIGHT LUMINAIRE IS TO INSTALL A PHOTO-ELECTRIC CELL ON EACH LUMINAIRE, IF LUMINAIRES ARE MOUNTED ON HIGHER POLES (IN EXCESS OF 10.7 M OR 35 FT.) WHERE IT IS DIFFICULT TO REACH THE LUMINAIRE WITH THE LOCAL DISTRICT BUCKET TRUCK, CONSIDERATION SHOULD BE GIVEN TO USING A PHOTO-ELECTRIC CONTROLLED EXTERNALLY-MOUNTED RELAY SYSTEM.

2. PHOTO-ELECTRIC CONTROLLED EXTERNALLY-MOUNTED RELAY

SEVERAL LUMINAIRES CAN BE CONTROLLED SIMULTANEOUSLY BY INSTALLING A PHOTO-ELECTRIC CONTROLLED, EXTERNALLY MOUNTED RELAY, ON A WOOD POLE (SEE CD315-11) OR ON A STEEL STREET LIGHT POLE (SEE CD315-12). SINGLE POLE (SINGLE CIRCUIT) RELAYS ARE AVAILABLE WITH EITHER A 30 AMP OR A 60 AMP RATING. A BY-PASS SWITCH MAY BE INSTALLED TO PROVIDE A MEANS OF ACTIVATING THE STREET LIGHT CIRCUIT FOR DAYLIGHT MAINTENANCE PURPOSES.

3. STREET LIGHT RELAY USING STREET LIGHT CONTROL

ACTIVATING SUCCESSIVE SECTIONS OF STREET LIGHTING CIRCUITS BY MEANS OF A SERIES OF RELAYS (KNOWN AS A CASCADE CONTROLLED SYSTEM) IS NO LONGER USED AS A CONTROL METHOD. HOWEVER, SOME CASCADE CONTROLLED RELAY SYSTEMS REMAIN IN SERVICE. THE CONNECTION DIAGRAMS FOR A CASCADE CONTROLLED RELAY SYSTEM ARE SHOWN ON DRAWING CD315-14. DOUBLE POLE (DOUBLE CIRCUIT) RELAYS ARE NO LONGER PURCHASED, THEREFORE, DOUBLE POLE RELAYS WHICH FAIL MUST BE REPLACED WITH TWO SINGLE POLE RELAYS. BOTH THE SINGLE AND DOUBLE POLE OLDER STYLE RELAYS HAVE A 5 AMP FUSE PROTECTING THE RELAY COIL.

4. STREET LIGHT RELAY USING PILOT WIRE CONTROL

PILOT WIRE CONTROL SYSTEMS ARE NO LONGER USED FOR NEW CONSTRUCTION. HOWEVER, SOME PILOT WIRE CONTROL SYSTEMS REMAIN IN SERVICE. THE CONNECTION DIAGRAMS FOR PILOT WIRE CONTROL SYSTEMS ARE SHOWN ON DRAWING CD315-15. DOUBLE POLE (DOUBLE CIRCUIT) RELAYS ARE NO LONGER PURCHASED. THEREFORE, DOUBLE POLE RELAYS WHICH FAIL MUST BE REPLACED WITH TWO SINGLE POLE RELAYS.

5. PHOTO-ELECTRIC CONTROLLED RELAY IN BASE OF STANDARD

COMPACT RELAYS, MOUNTED IN THE BASE OF STEEL STREET LIGHT STANDARDS ARE NO LONGER USED FOR NEW CONSTRUCTION. THE COMPACT RELAY IS ACTIVATED VIA THE PHOTO-ELECTRIC CONTROLLER ON THE LUMINAIRE. IF A COMPACT RELAY FAILS AN EXTERNALLY-MOUNTED RELAY AND PHOTO-ELECTRIC CONTROLLER SHOULD BE INSTALLED (SEE CD315-12 AND CD315-13).

APPROVED	REVISIONS		MANITOBA HYDRO DISTRIBUTION STANDARDS		
ORIGINAL DRAWING SEALED BY E.H. WIEBE 89-04-28			CONTROL METHODS FOR STREET LIGHT CONTROLS		
DRAWN W.B./CAD	CHECKED W.C.	DATE 88-08	CD 315-10		SHT 0001 OF 1
					REV 00

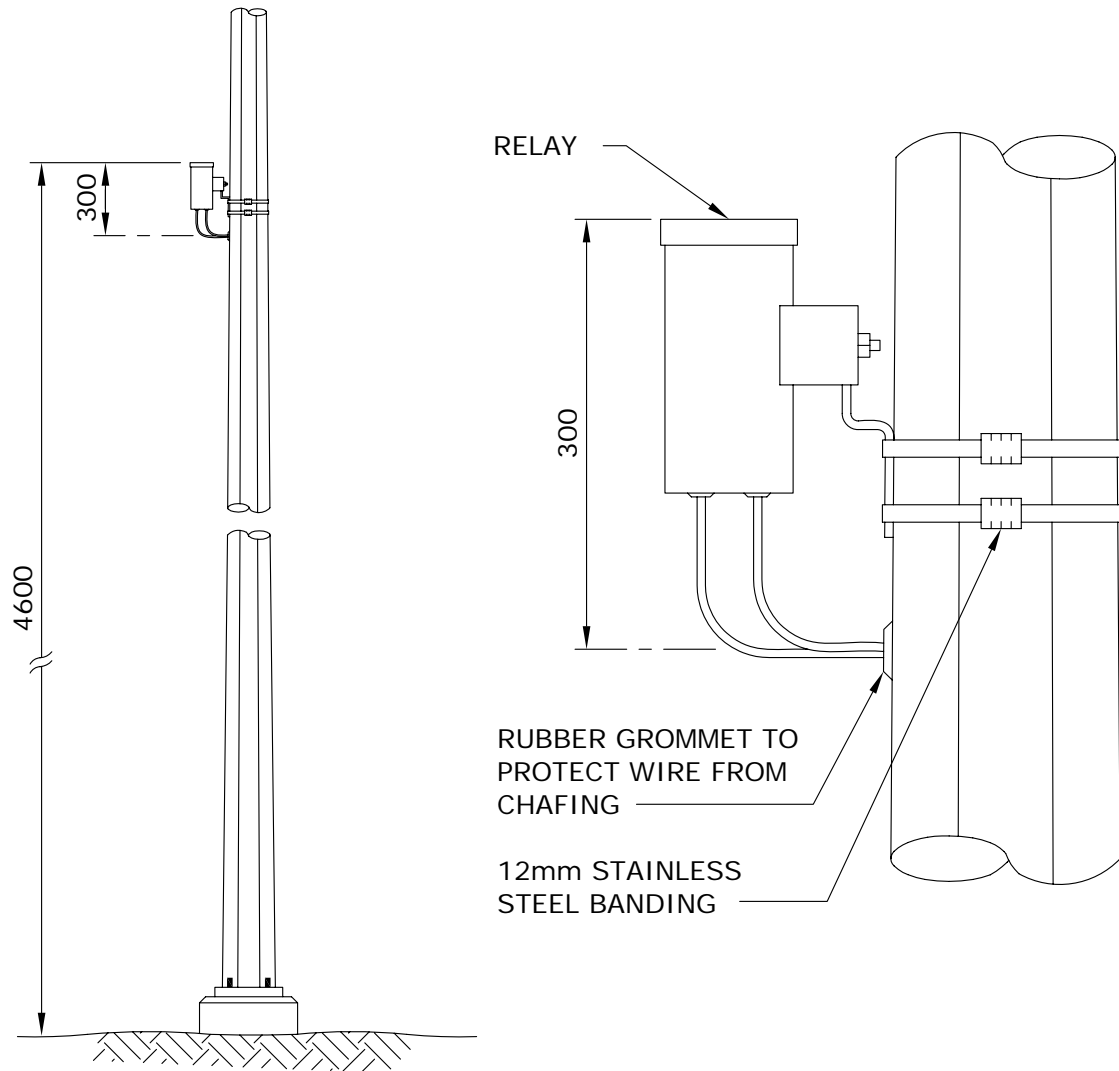

NOTES:

1. DRILL 25mm HOLE AT A POINT 4.3m ABOVE FINISHED GRADE.
2. INSTALL RUBBER GROMMET IN HOLE.
3. BAND RELAY TO POLE USING 12mm STAINLESS STEEL BANDING MATERIAL SO THAT THE TOP OF THE RELAY IS 300mm ABOVE THE CENTRE OF THE HOLE.
4. CONNECT RELAY LEADS TO 4.3m LENGTHS OF EQUAL SIZED CONDUCTOR AND PUSH SPLICES INSIDE POLE.
5. TAPE EXPOSED RELAY LEADS INTO A BUNDLE.
6. DIMENSIONS SHOWN ARE MILLIMETRES.

APPROVED		REVISIONS		MANITOBA HYDRO DISTRIBUTION STANDARDS					
ORIGINAL DRAWING SEALED BY E.H. WIEBE 89-04-28				INSTALLATION OF EXTERNALLY-MOUNTED RELAY					
DRAWN W.B./CAD	CHECKED W.C.	DATE 88-09	CD 315-12		<table border="1"> <tr> <td>SHT</td> <td>REV</td> </tr> <tr> <td>0001 OF 1</td> <td>00</td> </tr> </table>	SHT	REV	0001 OF 1	00
SHT	REV								
0001 OF 1	00								

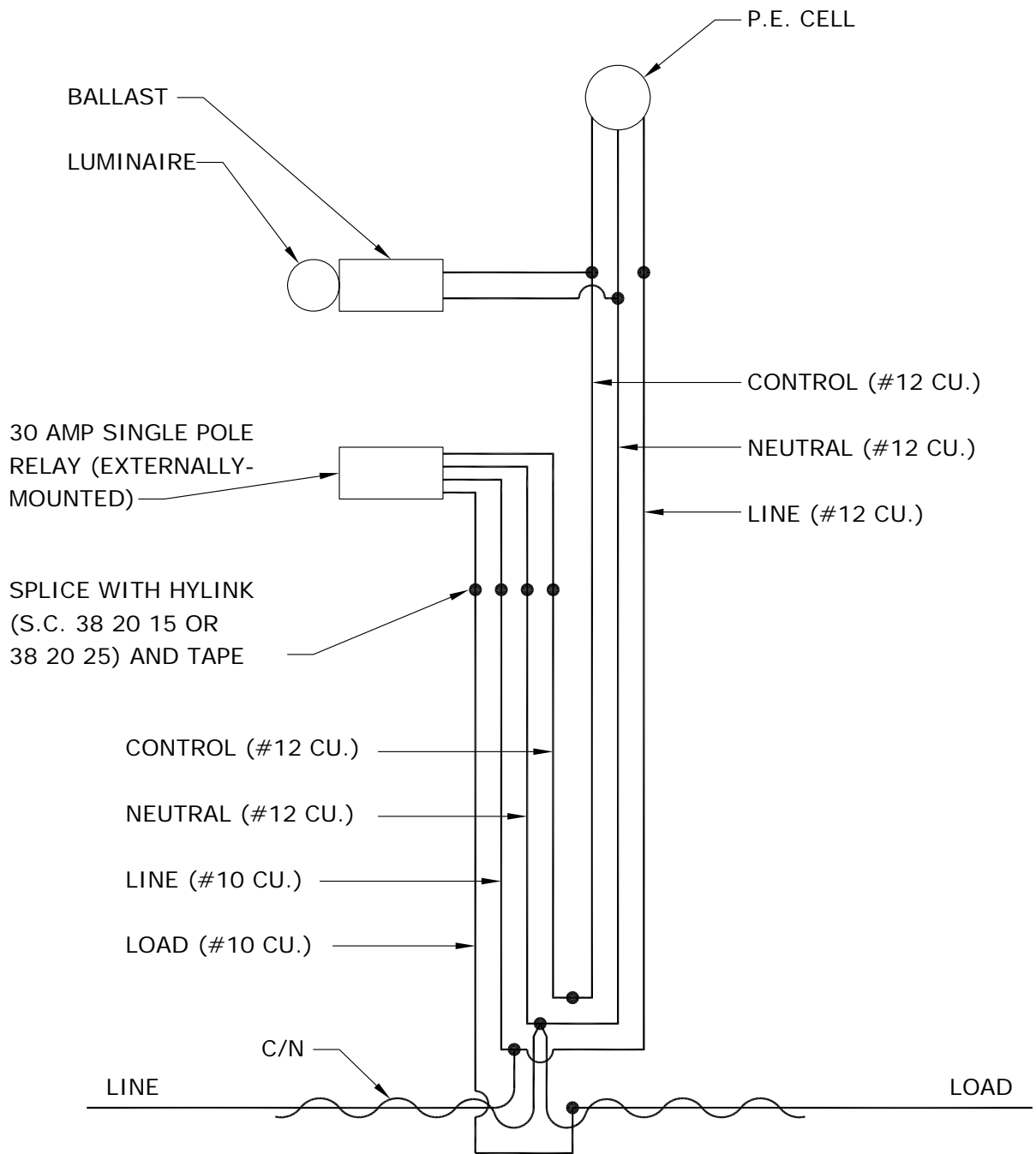

APPROVED		REVISIONS		MANITOBA HYDRO DISTRIBUTION STANDARDS	
ORIGINAL DRAWING SEALED BY E.H. WIEBE 89-04-28		94-03 1 MAXIMUM RELAY SIZE		CONNECTION SCHEMATIC FOR EXTERNALLY-MOUNTED RELAY	
DRAWN W.B./CAD	CHECKED W.C.	DATE 88-09	SHT 0001 OF 1		REV 01

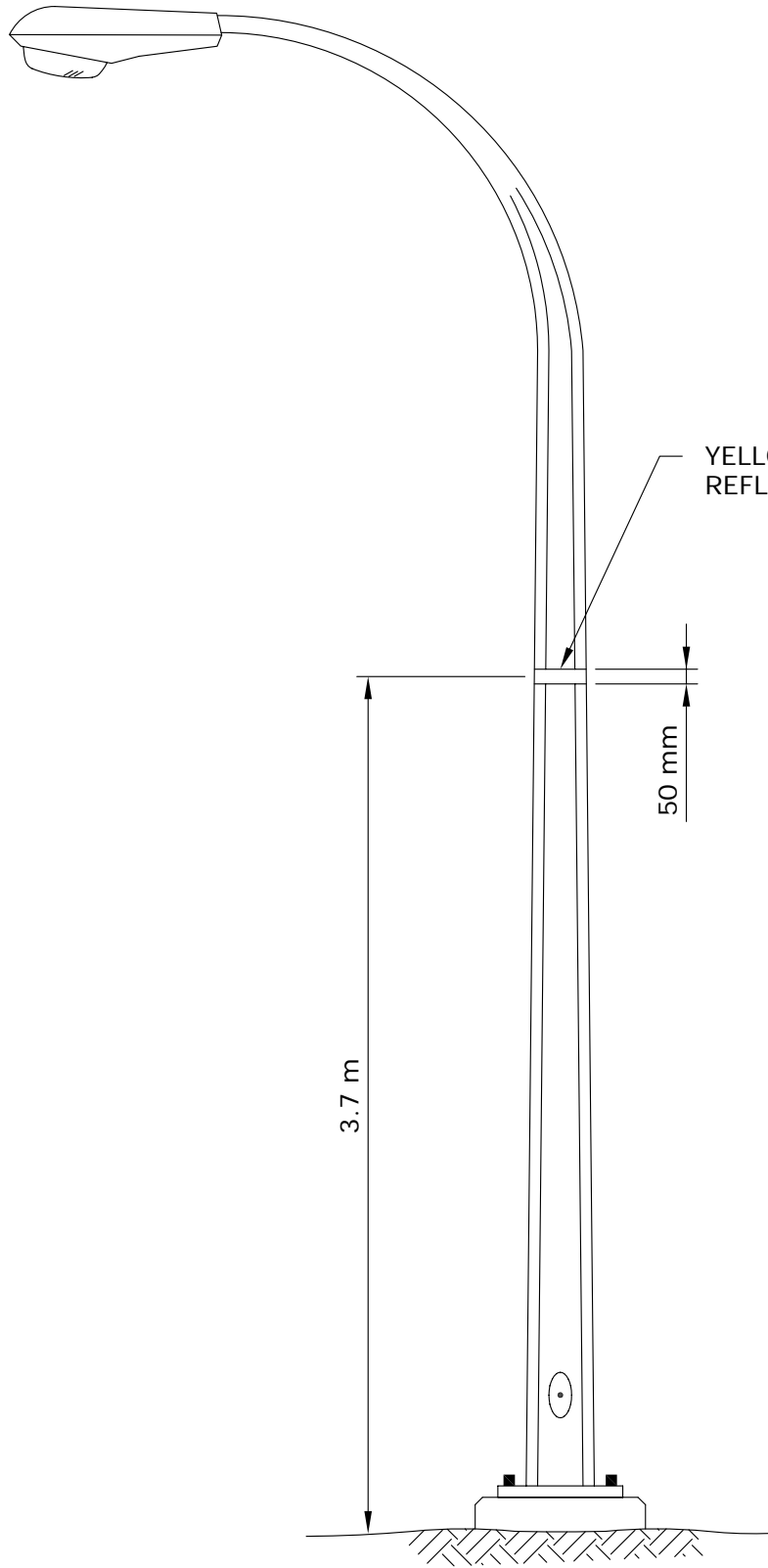

YELLOW SCOTCHLITE
REFLECTIVE TAPE

50 mm

3.7 m

APPROVED		REVISIONS		MANITOBA HYDRO DISTRIBUTION STANDARDS	
ORIGINAL DRAWING SEALED BY E.H. WIEBE 89-04-28				IDENTIFICATION OF FIRST STREET LIGHT STANDARD CONNECTION TO CIRCUIT	
DRAWN W.B./CAD		CHECKED W.C.	DATE 88-09		
				CD 315-35	

7.7 - 10.7 STREET LIGHT POLES

NOTES:

1. FOR FUTURE ACCESS TO LOWER PORTION OF PLASTIC PIPE, LOCATE "V" GROOVE SIDE OF BASE TO ROADWAY PROVIDED THAT:
 - a) A MIN. HORIZONTAL SEPARATION OF 350mm IS MAINTAINED TO ANY PAVED SURFACE OR STRUCTURE; OR
 - b) IF LESS THAN 350mm, ROTATE BASE 90°
2. ROUTE UNDERGROUND CABLES DIRECTLY INTO PLASTIC PIPE.
3. IN BACKFILL AREA, ENCASE UNDERGROUND CABLES IN A 75mm RADIUS ENVELOPE OF EXCAVATED MATERIAL OR SAND TO PROTECT CABLES. DO NOT BACKFILL WITH EXCAVATED MATERIAL OR SAND MORE THAN 1/6 OF THE WAY AROUND BASE.
4. SEE CD300-9 FOR ANCHOR ROD TIGHTENING METHOD.
5. INSTALL EXPANDING POLE KEY ANCHOR PER CD44-30. ENSURE TOP ANCHOR DOES NOT OBSTRUCT CONDUIT ENTRY HOLE.
6. FINISHED GRADE TO BE LEVEL FOR A MINIMUM OF 600mm AROUND BASE.
7. DIMENSIONS SHOWN ARE MILLIMETRES.

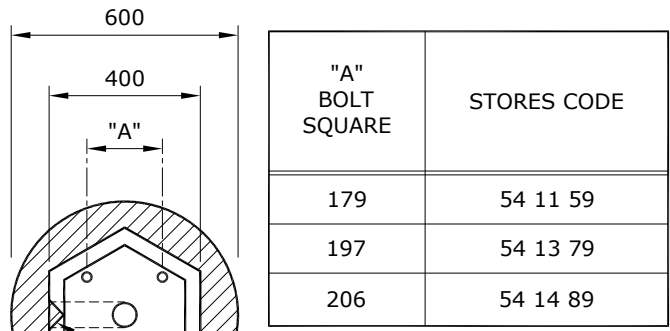

"A" BOLT SQUARE	STORES CODE
179	54 11 59
197	54 13 79
206	54 14 89

PLAN

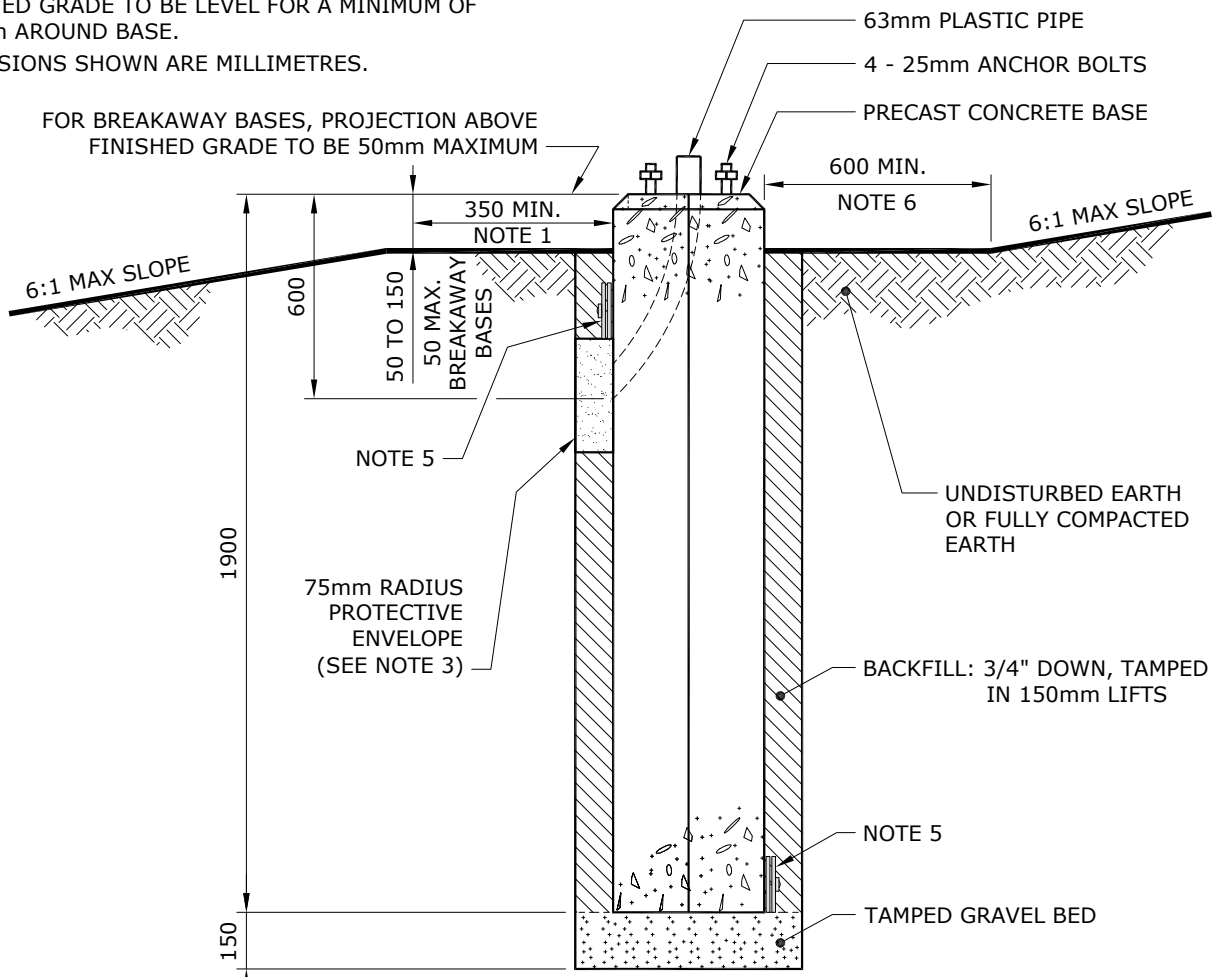

ELEVATION

APPROVED	REVISIONS	MANITOBA HYDRO DISTRIBUTION STANDARDS					
INSTALLATION OF PRECAST CONCRETE BASE ON SLOPE							
DRAWN C.A.	CHECKED L.D.	DATE 19-10	CD 300-7				
			<table style="width: 100%; border-collapse: collapse;"> <tr> <td style="width: 80%; text-align: right; padding: 2px;">SHT</td> <td style="width: 20%; text-align: center; padding: 2px;">REV</td> </tr> <tr> <td style="text-align: right; padding: 2px;">0001 OF 2</td> <td style="text-align: center; padding: 2px;">00</td> </tr> </table>	SHT	REV	0001 OF 2	00
SHT	REV						
0001 OF 2	00						

