

A1 SIZE - 594mm x 841mm
 LAST SAVE: 2012/08/22 - 3:17pm
 PATH: M:\508955\ENGL\47ELE\DD - General DWG\1-0630M-E0064-001-01.dwg

ELEMENTARY DIAGRAM:

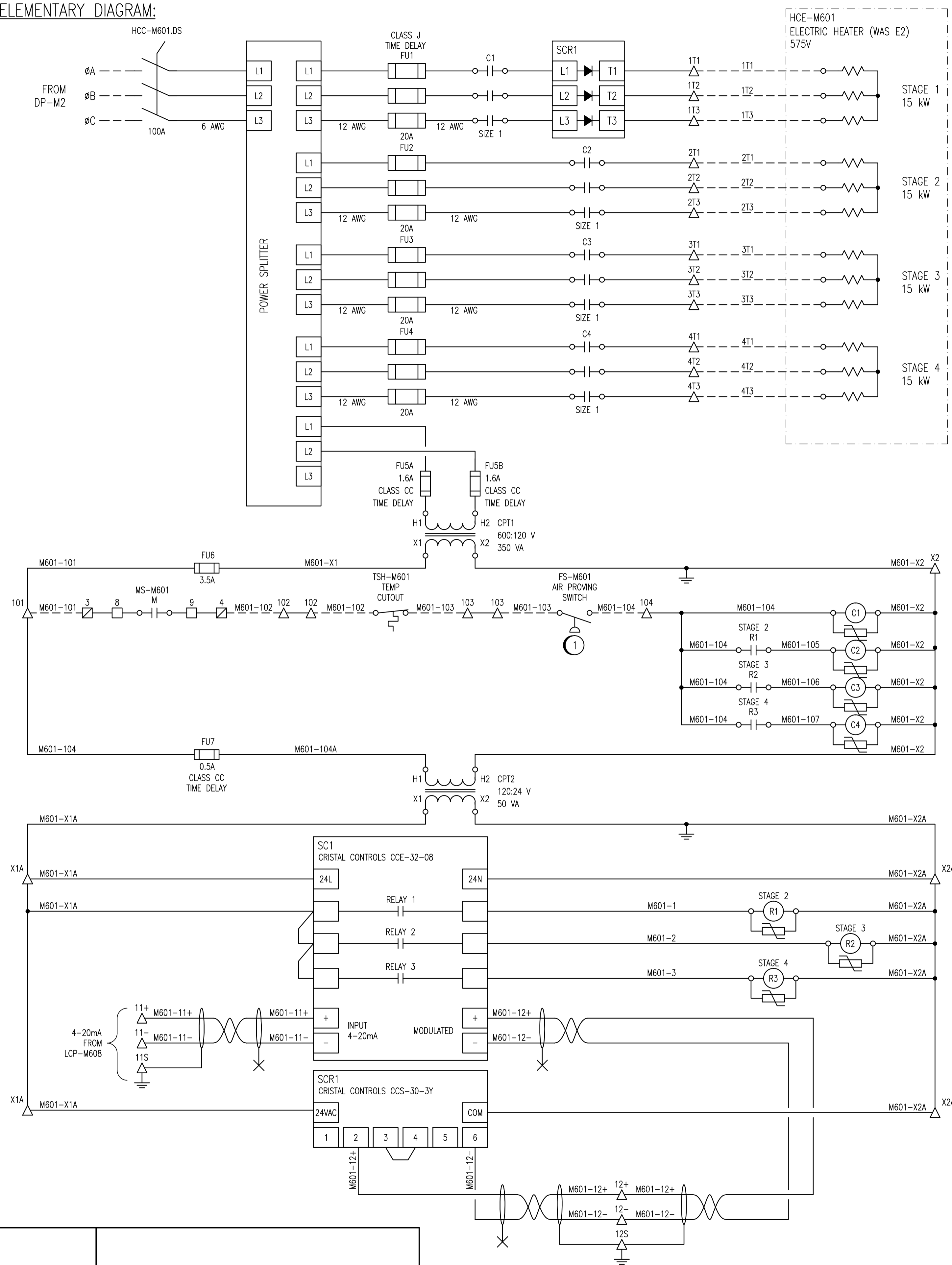

CONNECTION DIAGRAM:

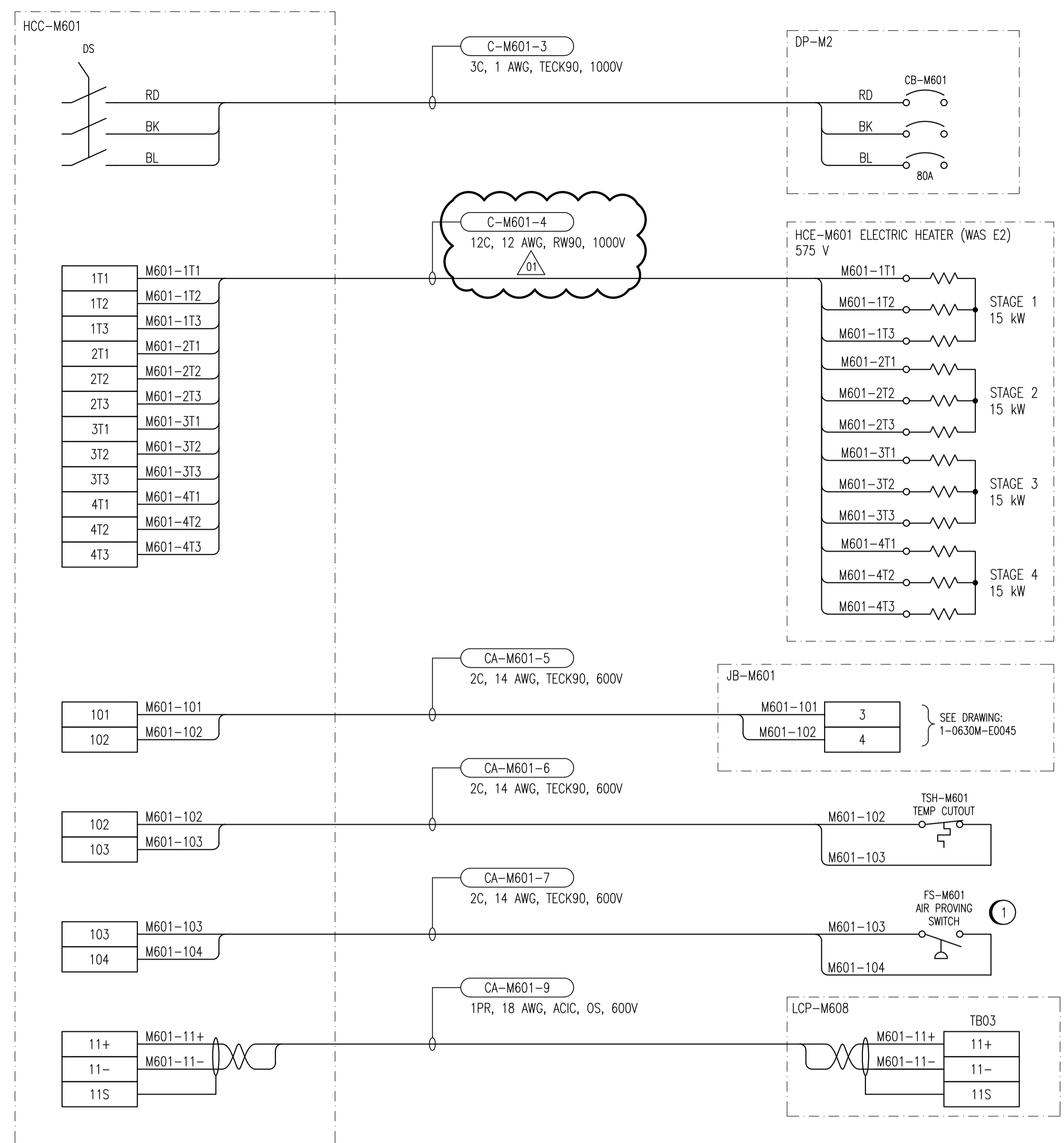

CONSTRUCTION NOTES:

- 1 SUPPLY AND INSTALL NEW AIR PROVING SWITCH.

LEGEND:

- △ TERMINAL IN CONTACTOR PANEL
- TERMINAL IN AHU-M601 STARTER
- ▣ TERMINAL IN JB-M601
- ▭ TRANSIENT VOLTAGE SUPPRESSOR

1-0630M-A0035 AHU-M601 DISCHARGE AIR TEMP. LOOP DIAGRAM
 DRAWING NUMBER REFERENCE DRAWINGS



NO.	REVISIONS	DATE	DESIGN	CHECK
01	ADDENDUM 2, BID OPP. 490-2012	2012/08/22	BJC	CJR
00	ISSUED FOR TENDER, BID OPP. 490-2012	2012/07/23	BJC	CJR

 SNC-Lavalin Inc. 148 Nature Park Way Winnipeg, MB, Canada R3P 0X7 204-786-8080	
DESIGNED BY: B. CLEVEN	CHECKED BY: C. REIMER
DRAWN BY: M.J. PERSSON	APPROVED BY: C. REIMER
SCALE: NTS	RELEASED FOR CONSTRUCTION BY: DATE: 2012/05/14
CONSULTANT NO.: 508955-0000-47DD-0064	

ENGINEER'S SEAL
PRELIMINARY
 NOT TO BE
 USED FOR
 CONSTRUCTION

THE CITY OF WINNIPEG
 WATER AND WASTE DEPARTMENT
 MACLEAN WATER PUMPING STATION
 CONTACTOR SCHEMATIC
 HCC-M601
 ELECTRIC HEATING COIL FOR AHU-M601
 CITY DRAWING NUMBER: 1-0630M-E0064
 SHEET: 001
 REV: 01
 SIZE: A1
 1-0630M-E0064-001-01.dwg