



Water and Waste
Eaux et déchets

Environmental Standards Division

BRADY ROAD RESOURCE MANAGEMENT FACILITY ANNUAL REPORT - 2020



HEATHER DEMCHENKO B.Sc.
COMPLIANCE REPORTING TECHNICIAN

CHRIS KOZAK C.E.T.
SUPERVISOR OF ENVIRONMENTAL MONITORING AND REPORTING

NANCY CRAWFORD B.Sc.
COMPLIANCE REPORTING BRANCH HEAD

RENÉE GROSSELLE B.Sc.
MANAGER OF ENVIRONMENTAL STANDARDS

BRADY ROAD RESOURCE MANAGEMENT FACILITY ANNUAL REPORT – 2020

EXECUTIVE SUMMARY

The Brady Road Resource Management Facility (BRRMF) is the City of Winnipeg's only active landfill. The site is bordered by the Perimeter Highway on the North, Waverley Street on the East, Brady Road and the R.M. of Macdonald on the West, and Rue des Trappistes on the South. The landfill has been in operation since 1973 and is estimated to have sufficient capacity for over 100 years, assuming current waste diversion practices are continued.

Environment Act Licence No. 3081 R, issued on April 23, 2014, requires the City of Winnipeg to submit an annual report on or before April 15th, detailing activities conducted at BRRMF in the previous year. This report provides a summary of major expenditures and construction, major incidents, waste diversion operations, ground water management, surface water management, leachate management, landfill gas management, and nuisance management for 2020.

Major construction in 2020 included expansion of the landfill gas collection system and improvements to the landfill gas and leachate collection systems. In 2020, there were no disruptions or failures of waste management practices due to equipment breakdown, no major spills occurred, and no alarms were activated.

In 2020, approximately 37% of the 552,543 metric tonnes of material received at the BRRMF were beneficially re-used, composted, or removed from the site for further processing or beneficial re-use. In addition, 46,374 kL of leachate was hauled to the North End Sewage Treatment Plant for treatment.

Monitoring programs for leachate, ground water, surface water, and subsurface gas migration followed the sampling and analysis plans in 2020 and contingency plans were not activated.

Statistical analyses of analytical results obtained for leachate, ground water, and surface water indicate that the BRRMF has not had a negative impact on the ground water and surface water downstream of the site.

BRADY ROAD RESOURCE MANAGEMENT FACILITY ANNUAL REPORT – 2020

CONTENTS

1.0	INTRODUCTION	1
2.0	CONSTRUCTION	2
3.0	MAJOR INCIDENTS	2
4.0	WASTE DIVERSION OPERATIONS	3
5.0	GROUND WATER, SURFACE WATER, LEACHATE, AND LANDFILL GAS MONITORING	5
5.1	GROUND WATER	5
5.2	SURFACE WATER	15
5.3	LEACHATE	21
5.4	LANDFILL GAS	27
	5.4.1 COLLECTION AND FLARING SYSTEM	27
	5.4.2 SUBSURFACE LANDFILL GAS MONITORING PROGRAM	27
6.0	NUISANCE MANAGEMENT	35
7.0	CONCLUSION	39
8.0	REFERENCES	39

TABLES

TABLE 1.	2020 BRRMF WASTE DIVERSION SUMMARY	4
TABLE 2.	2020 GROUND WATER DATA	7
2.1	CLAY	7
2.2	TILL	8
2.3	BEDROCK	10
TABLE 3.	2020 GROUND WATER QUALITY COMPARISON	12
3.1	CLAY	12
3.2	TILL	13
3.3	BEDROCK	14
TABLE 4.	2020 WEEKLY WEIR DATA	17
TABLE 5.	2020 SURFACE WATER DATA	18
5.1	PONDS	18
5.2	PERIMETER DITCH	19
TABLE 6.	2020 SURFACE WATER PERIMETER DITCH COMPARISON	20
TABLE 7.	2020 LEACHATE LEVELS	22
TABLE 8.	2020 LEACHATE DATA	23
TABLE 9.	2020 LEACHATE QUALITY COMPARISON	25
TABLE 10.	2020 EXTERNAL GAS PROBE MONITORING	28
TABLE 11.	2020 NUISANCE COMPLAINT MONITORING	36



BRADY ROAD RESOURCE MANAGEMENT FACILITY ANNUAL REPORT – 2020

FIGURES

FIGURE 1. BRRMF LAYOUT & LEACHATE COLLECTION SYSTEM

FIGURE 2. GROUND WATER SAMPLING LOCATIONS

FIGURE 3. SURFACE WATER SAMPLING LOCATIONS

APPENDICES

APPENDIX A. 2020 BRRMF TONNAGE SPREADSHEET

APPENDIX B. PIPER DIAGRAMS

APPENDIX C. TIME VS CONCENTRATION GRAPHS

APPENDIX D. 2020 LANDFILL GAS COLLECTION AND FLARING REPORT

BRADY ROAD RESOURCE MANAGEMENT FACILITY ANNUAL REPORT – 2020

1.0 INTRODUCTION

The Brady Road Resource Management Facility (BRRMF) is located south of the Perimeter Highway, between Brady Road and Waverley Street. Residential land use is present within 500 m of the site to the east and within 120 m north of the site (Waverly West development), other surrounding land use is agricultural. Opened in 1973, the 790-hectare, Class 1 Solid Waste Disposal facility currently holds approximately 12 million metric tonnes of waste, with over 300,000 metric tonnes of waste materials landfilled on an annual basis. The site has capacity for over 100 additional years of waste disposal, assuming current waste diversion practices are continued.

The BRRMF operates in accordance with Environment Act Licence No. 3081 R, which was issued on April 23, 2014. Clause 127 of the license requires the City of Winnipeg to prepare and submit an Annual Report on the activities undertaken at the site during the previous year on or before April 15th of each year. This report contains results and/or comments for each of the clauses of Licence No. 3081 R under which the BRRMF has generated pertinent information during 2020. The report also provides information on the BRRMF proposed activities for 2021.

The layouts of the primary components of the BRRMF are shown on Figure 1. Surface water flows are managed by perimeter ditching and retention ponds. The ground water monitoring system consists of wells in the bedrock, till, and clay layers. The leachate collection system is a network of manholes/risers, drains, and sumps around the perimeter of the landfill cells, which feed into a centralized collection tank/truck fill station. The landfill gas (LFG) management system includes extraction wells, collection piping, and a blower/enclosed flare station.

BRADY ROAD RESOURCE MANAGEMENT FACILITY ANNUAL REPORT – 2020

2.0 MAJOR ACTIVITIES AND CONSTRUCTION

Major activities and construction undertaken in 2020 included:

- installation of four horizontal gas collectors in Cell 32 under newly deposited waste
- installation of a second sub-lateral pipe to the eastern limit of Cell 33 for connection to future horizontal gas collectors
- addition of 18 wells to the LFG collection system, the new wells are equipped with pneumatic pumps for leachate extraction
- retrofit of 57 existing gas wells with pneumatic pumps for leachate extraction
- retrofit of three existing leachate manholes for LFG collection
- installation of gas tight lids at 24 leachate manholes and sumps to reduce odors
- Installation of compressed air and force main piping to all vertical extraction wells

Major activities and construction planned for 2021 include:

- installation of an air compressor system in the LFG flaring compound to power the pneumatic pumps in the wells
- construction and commissioning of a new waste cell (Cell 33)

3.0 MAJOR INCIDENTS

In 2020, there were no disruptions or failures of waste management practices due to equipment breakdown, no major spills occurred, and no alarms were activated.

BRADY ROAD RESOURCE MANAGEMENT FACILITY ANNUAL REPORT – 2020

4.0 WASTE DIVERSION OPERATIONS

In 2020, the BRRMF received 552,543 metric tonnes of material: 202,299 metric tonnes were composted or re-used on-site, 3,962 metric tonnes were removed from the BRRMF for further processing or beneficial re-use, and 346,282 metric tonnes were landfilled. This translates to a diversion rate of 37%, which is a decrease from the 2019 diversion rate of 50%.

The amount of biosolids landfilled continued to decrease from previous years because they continue to be diverted to the soil fabrication pilot project at the Summit Landfill and the land application project. The BRRMF accepted significantly lower amounts of clean fill in 2020 because there is already a surplus stockpiled for use as final cover. In 2020, there was an increase in the amount of residential waste received, this is likely a result of the COVID-19 pandemic. In October 2020, the two-year Residential Food Waste Collection Pilot Project began. The feasibility of a city-wide program will be determined by the pilot project, which involves weekly curbside collection of residential food waste from approximately 4,000 households. In 2020, the pilot project diverted a total of 115 metric tonnes of organics from the landfill and into the leaf and yard waste composting operation, the resulting compost will be beneficially used onsite at the BRRMF. In 2021, we will continue to compost biosolids, divert wood waste, and continue the Residential Food Waste Collection Pilot Program.

A summary of the BRRMF Waste Diversion Operations is provided in Table 1, the 2020 BRRMF Tonnage Spreadsheet is provided in Appendix A.



**Water and Waste
Eaux et déchets**

**Table 1. 2020 BRRMF
Waste Diversion Summary**

	2015	2016	2017	2018	2019	2020
Total Materials Received (a) = (b) + (c) + (d)	460,506	434,403	658,871	682,779	637,453	552,542
Materials Landfilled						
Biosolids	44,717	44,652	42,397	33,030	20,365	16,725
Residential Waste Collection	177,846	174,280	172,209	172,041	174,050	194,570
Wastes from 4R Depots	n/a	15,872	12,806	12,175	12,883	15,561
Wastes from City Operations (street cleaning refuse, grit, non-recyclables from recycling facility, etc...)	19,611	20,878	23,595	20,864	19,323	28,671
Wastes from Other Municipalities	3,594	4,729	3,505	20	0	0
Miscellaneous Wastes (dead animals, asbestos, hospital waste, construction/demolition waste, etc...)	144,205	96,834	93,851	88,813	93,621	90,755
Total Landfilled (b)	389,974	357,246	348,364	326,942	320,242	346,282
Materials Composted or Reused On Site						
Biosolids	3,939	1,899	4,942	1,541	1,916	1,219
Ceramic	n/a	164	245	296	331	281
Clean Fill	4,957	6,198	247,852	281,546	252,113	136,675
Compostable Materials (retention pond dredgings, street leaves, leaf and yard waste)	33,475	34,726	28,532	33,041	31,525	37,253
Residential Food Waste Collection	n/a	n/a	n/a	n/a	n/a	115
Concrete	362	1,338	2,801	5,187	6,565	10,145
Glass	9,339	11,534	11,181	12,338	10,965	8,942
Lumber	n/a	187	185	202	192	91
Sweepings (sand)	10,814	11,620	398	259	223	995
Trees and Wood Chips	6,442	7,521	8,860	7,080	5,168	6,583
Total Composted or Reused (c)	69,328	75,187	304,998	341,489	308,999	202,299
Materials Removed from Site*						
Batteries	0	24	33	49	74	79
Bicycles	n/a	13	11	6	9	14
City Compost	343	403	3,287	11,483	5,166	391
Dutch Elm	19	3	102	111	0	0
Electronics	n/a	375	530	570	665	713
Household Hazardous Waste	n/a	303	341	594	686	826
Mattresses	n/a	n/a	n/a	n/a	233	316
Oil	n/a	22	32	60	90	124
Oversized Plastics	n/a	15	22	52	43	22
Ozone-Containing Appliances	78	66	111	180	166	190
Recyclables	n/a	156	274	471	278	283
Scrap Metal	543	532	619	607	635	726
Tires	222	57	146	165	166	277
Total Removed from Site (d)	1,205	1,970	5,510	14,348	8,213	3,962
Diversion Rate = (c) + (d) / (a)	15%	18%	47%	52%	50%	37%

* Materials removed from site are stockpiled until sufficient quantities are collected

BRADY ROAD RESOURCE MANAGEMENT FACILITY ANNUAL REPORT – 2020**5.0 GROUND WATER, SURFACE WATER, LEACHATE, AND LANDFILL GAS MONITORING**

5.1 GROUND WATER

The land beneath the BRRMF consists of three layers: the uppermost layer is clay (averaging 12 m in thickness), the second layer is till (averaging 6 m in thickness), and the lowest layer is bedrock. Ground water flows downwards through the clay and till layers into the bedrock aquifer, which flows in a north-east direction. The ground water in all three layers is saline and non-potable. The major ions in the ground water from the clay layer are calcium, magnesium, sulfate and bicarbonate. Sodium and chloride are the major ions in the bedrock aquifer. Ground water in the till layer is generally intermediate in brackishness and shows a gradual change with depth. The ground water monitoring system includes 34 nested wells: 13 bedrock wells, 13 till wells, and 8 clay wells. The locations of the ground water monitoring wells are shown on Figure 2.

As per the BRRMF Operating Plan, ground water is monitored in accordance with the Ground Water Sampling and Analysis Plan (SAP), as specified under Clause 123. Sampling frequency is twice per year for bedrock wells and downgradient till wells, and once per year for clay wells and other till wells distant from the waste areas. As neither Federal nor Manitoba Provincial Governments regulate non-potable ground water quality, the Ontario Ministry of Environment (MOE) guidelines for non-potable groundwater quality are used as the regulatory guideline (MOE, 2011).

In 2020, a total of 53 ground water samples were analyzed – 5 samples from wells upgradient of the site (background water quality), and 48 samples from wells cross gradient and downgradient of the site. There were no deviations from the Ground Water SAP or from normal sample collection and preservation practices. Well GWQ25-W10 was decommissioned and redrilled approximately 10 metres to the South to accommodate a new service road. The majority of results met the guidelines with the exception of chloride in some till and bedrock wells, and hydrocarbons in one of the till wells. The 2020 ground water results are provided in Tables 2.1-2.3.

The 2014-2020 average values are provided in Tables 3.1-3.3. Some variability from historical data was observed in some of the samples, this may be a statistical anomaly; we will continue to monitor these parameters to better evaluate trends. The Piper diagrams provided in Appendix B display tight groupings of ground water sampling data, which is indicative of no significant ground water chemical changes.

BRADY ROAD RESOURCE MANAGEMENT FACILITY ANNUAL REPORT – 2020

Time versus concentration graphs provided in Appendix C show the historical relationship of the analytical parameters at each monitoring location. In general, the analytical results for ground water obtained in 2020 were found to be similar to those obtained in 2014-2019, and are consistent with background levels.

The Contingency Action Plan identified under Clause 125 was not implemented in 2020.

At this time, we have no recommendations for changes to the ground water monitoring program.

Brady Road Resource Management Facility Annual Report – 2020



Water and Waste Eaux et déchets

Table 2.1 2020 Ground Water Monitoring - Clay Wells

	Units	Criteria*	Upgradient		Downgradient and Crossgradient					
			GWQ25-6N60DR	GWQ25-5N62D	GWQ25-6N63E	GWQ25-6N57DR	GWQ25-6N67E	GWQ25-4N34B	GWQ25-4N34C	GWQ25-6N59DR
			Spring	Spring	Spring	Spring	Spring	Spring	Spring	Spring
Inorganic Parameters										
Alkalinity - Bicarbonate	mg/L		528	499	577	560	456	663	631	496
Alkalinity - Carbonate	mg/L		<3.0	<3.0	<3.0	<3.0	<3.0	<3.0	<3.0	<3.0
Alkalinity - Hydroxide	mg/L		<3.0	<3.0	<3.0	<3.0	<3.0	<3.0	<3.0	<3.0
Alkalinity - Total	mg/L		528	499	577	560	456	663	631	496
Dissolved Hardness (CaCO3)	mg/L		1,370	2,260	1,690	1,760	1,370	1,720	1,900	1,740
pH	units		6.81	6.94	6.88	6.91	6.90	7.03	6.90	6.80
Specific Conductivity	(µS/cm)		4,820	8,990	6,470	6,160	4,790	7,160	5,850	6,240
Turbidity	(ntu)		122	12.1	11.3	6.85	7.43	31.4	2,219	18.1
Total Dissolved Solids	mg/L		3,960	7,350	5,400	5,010	3,860	6,560	4,450	5,000
Total Suspended Solids	mg/L		183	436	59	133	177	226	6,574	393
Total Solids	mg/L		4,140	7,790	5,460	5,140	4,040	6,790	11,000	5,390
Dissolved Chloride (Cl)	mg/L	2,300	369	1,640	890	560	630	1,800	1,000	880
Dissolved Sulphate (SO4)	mg/L		1,680	2,430	2,110	2,230	1,640	2,360	1,870	2,130
Nutrients										
Ammonia - Dissolved	mg/L N		0.012	0.680	0.526	0.060	0.679	0.005	0.537	0.05
Nitrate - Dissolved	mg/L N		0.923	0.147	0.105	1.040	0.006	0.064	0.237	1.26
Total Kjeldahl Nitrogen	mg/L N		0.2	1.7	1.4	<0.2	1.2	0.9	2.7	0.3
Phosphorus - Dissolved	mg/L P		0.027	0.025	0.027	0.027	0.027	0.027	0.028	0.025
Other										
Cyanide - Total (CN)	mg/L	0.066	<0.0010	<0.0010	<0.0010	<0.0010	<0.0010	<0.0010	<0.0010	<0.0010
Organic Indicators										
Carbonaceous Oxygen Demand	mg/L		47	100	49	41	29	46	360	52
Total Organic Carbon	mg/L		9.9	23.6	27.8	40.0	19.8	37.8	82.4	32.4
Metals										
Arsenic (As)- Dissolved	mg/L	1.9	0.00048	0.00149	0.00078	0.00066	0.00081	0.00093	0.00090	0.00056
Barium (Ba)- Dissolved	mg/L	29	0.0087	0.0115	0.0158	0.0098	0.0125	0.0110	0.0092	0.0118
Beryllium (Be)- Dissolved	mg/L	0.067	<0.00010	<0.00010	<0.00010	<0.00010	<0.00010	<0.00010	<0.00010	<0.00010
Cadmium (Cd)- Dissolved	mg/L	0.0027	0.000026	0.000138	0.000139	0.000160	0.000086	0.000058	0.000031	0.000375
Calcium (Ca)- Dissolved	mg/L		405	803	647	622	535	565	411	596
Chromium (Cr)- Dissolved	mg/L	0.81	<0.00010	<0.00010	<0.00010	<0.00010	<0.00010	0.00010	<0.00010	<0.00010
Copper (Cu)- Dissolved	mg/L	0.087	0.00187	0.00258	0.00239	0.00244	0.00223	0.00229	0.00228	0.00524
Iron (Fe)- Dissolved	mg/L		0.0160	<0.0100	0.0390	0.0160	<0.0100	<0.0100	<0.0100	<0.0100
Lead (Pb)- Dissolved	mg/L	0.025	<0.000050	<0.000050	<0.000050	<0.000050	0.000053	<0.000050	<0.000050	0.000075
Magnesium (Mg)- Dissolved	mg/L		160	501	236	187	160	425	308	181
Manganese (Mn)- Dissolved	mg/L		1.10	2.00	2.52	1.72	1.16	0.034	0.662	2.17
Mercury (Hg)- Total	mg/L	0.0028	<0.0000050	<0.0000050	<0.0000050	<0.0000050	<0.0000050	0.0000050	0.000460	<0.0000050
Nickel (Ni)- Dissolved	mg/L	0.49	0.0064	0.0120	0.0113	0.0094	0.0069	0.0110	0.0062	0.0081
Potassium (K)- Dissolved	mg/L		9.82	14.2	10.8	10.7	9.18	10.2	8.89	10.9
Selenium (Se)- Dissolved	mg/L	0.063	0.000069	0.000259	0.000708	0.000183	0.000127	0.000808	0.001120	0.000156
Silver (Ag)- Dissolved	mg/L	0.0015	<0.000010	<0.000010	<0.000010	<0.000010	<0.000010	0.000013	<0.000010	<0.000010
Sodium (Na)- Dissolved	mg/L	2,300	267	690	481	401	236	344	388	367
Zinc (Zn)- Dissolved	mg/L	1.1	0.0064	0.0075	0.0098	0.0068	0.0047	0.0024	0.0047	0.0069
Field Parameters										
pH	units		7.44	7.80	7.17	7.27	7.26	7.38	7.30	7.21
Specific Conductivity	(µS/cm)		4,050	7,130	5,050	4,150	3,900	5,440	4,440	4,960
Polycyclic Aromatic Hydrocarbons										
Naphthalene	mg/L	6.4	<0.000050							
Benzo(a)pyrene	mg/L	0.00081	<0.000005							
Anthracene	mg/L	0.0024	<0.000010							
Petroleum Hydrocarbons										
F1 (C6-C10 Hydrocarbons)	mg/L	0.75	<0.10							
F2 (C10-C16 Hydrocarbons)	mg/L	0.15	<0.10							
F3 (C16-C34 Hydrocarbons)	mg/L	0.50	<0.250							
F4 (C34-C50 Hydrocarbons)	mg/L	0.50	<0.250							
Benzene	mg/L	0.43	<0.00050							
EthylBenzene	mg/L	2.3	<0.00050							
Toluene	mg/L	18	<0.00050							
Xylene (Total)	mg/L	4.2	<0.00064							
Volatile Organic Carbons										
Vinyl chloride	mg/L	0.0017	<0.0005							
Pesticides										
Diazinon	µg/L		<0.10							
Herbicides										
2,4-D	mg/L		<0.0001							

Note: Criteria from Ontario Ministry of the Environment. (2011, July 1). Soil, Ground Water and Sediment Standards for Use Under Part XV.I of the Environmental Protection Act Table 3: Full Depth Generic Site Condition Standards in a Non-Potable Ground Water Condition

Note: Criteria exceedences are highlighted in red.

* Criteria for total chloride and total metals

Brady Road Resource Management Facility Annual Report – 2020



**Water and Waste
Eaux et déchets**

Table 2.2 2020 Ground Water Monitoring - Till Wells

	Units	Criteria*	Upgradient		Downgradient and Crossgradient									
			GWQ25-6N60ER		GWQ25-5N62E		GWQ25-W13A		GWQ25-W14A		GWQ25-W15A		GWQ25-W16A	
			Spring	Autumn	Spring	Autumn	Spring	Autumn	Spring	Autumn	Spring	Autumn	Spring	Autumn
Inorganic Parameters														
Alkalinity - Bicarbonate	mg/L		587	557	545	191	559	436	1,610	927	419	406	415	354
Alkalinity - Carbonate	mg/L		<3.0	<3.0	<3.0	<3.0	<3.0	<3.0	<3.0	<3.0	<3.0	<3.0	<3.0	<3.0
Alkalinity - Hydroxide	mg/L		<3.0	<3.0	<3.0	<3.0	<3.0	<3.0	<3.0	<3.0	<3.0	<3.0	<3.0	<3.0
Alkalinity - Total	mg/L		587	557	545	191	559	436	1,610	927	419	406	415	354
Dissolved Hardness (CaCO3)	mg/L		1,200	1,280	1,470	1,160	1,130	2,230	2,670	2,930	8,370	6,660	1,950	1,350
pH	units		6.94	6.96	7.37	7.24	7.13	7.50	7.43	7.47	6.86	7.01	7.06	7.40
Specific Conductivity	(µS/cm)		4,140	4,020	8,650	8,120	6,710	6,750	8,710	7,920	7,080	6,520	5,400	5,070
Turbidity	(ntu)		193	178	942	2,692	151	193	2,532	>4,800	12,816	>4,800	451	22
Total Dissolved Solids	mg/L		3,330	3,240	5,350	5,090	3,290	2,590	5,290	4,160	6,290	1,310	3,970	3,620
Total Suspended Solids	mg/L		602	560	1,154	829	17,950	7,890	4,218	6,780	31,400	27,520	1,810	333
Total Solids	mg/L		3,930	3,800	6,500	5,920	21,200	10,500	9,510	10,900	37,700	28,800	5,780	3,960
Dissolved Chloride (Cl)	mg/L	2,300	340	470	2,210	2,380	1,230	1,550	2,240	2,480	1,360	1,350	970	990
Dissolved Sulphate (SO4)	mg/L		1,410	1,400	2,010	863	1,300	1,230	1,940	833	1,590	1,780	1,130	1,140
Nutrients														
Ammonia - Dissolved	mg/L N		0.186	0.209	0.849	0.982	0.491	0.437	1.13	1.08	1.00	0.936	0.799	0.483
Nitrate - Dissolved	mg/L N		0.638	0.538	0.111	0.078	0.115	0.076	0.019	<0.003	0.035	0.040	0.232	0.499
Total Kjeldahl Nitrogen	mg/L N		0.3	0.4	0.9	0.9	<0.2	1.1	1.9	1.7	1.8	4.3	<0.2	0.5
Phosphorus - Dissolved	mg/L P		0.025	0.021	0.015	<0.013	0.068	0.020	0.030	<0.013	0.076	0.023	0.039	0.020
Other														
Cyanide - Total (CN)	mg/L	0.066	<0.0010	<0.0010	<0.0010	<0.0010	<0.0010		<0.0010		<0.0010		<0.0010	
Organic Indicators														
Carbonaceous Oxygen Demand	mg/L		35	50	108	228	61	277	<100	190	1,660	1,080	80	66
Total Organic Carbon	mg/L		8.1	8.6	3.4	2.4	5.4	20.3	10.4	10.0	166.5	98.0	10.4	5.0
Metals														
Arsenic (As)- Dissolved	mg/L	1.9	0.00115	0.00080	0.00170	0.00180	0.00129	0.00111	0.00192	0.00673	0.00131	0.00144	0.00055	0.00087
Barium (Ba)- Dissolved	mg/L	29	0.0092	0.0076	0.0120	0.0127	0.0154	0.0135	0.0143	0.0139	0.0143	0.0160	0.0120	0.0107
Beryllium (Be)- Dissolved	mg/L	0.067	<0.00010	<0.00010	<0.00010	<0.00010	<0.00010	<0.00010	<0.00010	<0.00010	<0.00010	<0.00010	<0.00010	<0.00010
Cadmium (Cd)- Dissolved	mg/L	0.0027	0.000013	0.000031	0.000007	<0.000005	0.000027	0.000021	0.000025	0.000018	0.000044	0.000048	0.000044	0.000051
Calcium (Ca)- Dissolved	mg/L		392	439	304	372	388	503	390	375	751	750	493	480
Chromium (Cr)- Dissolved	mg/L	0.81	<0.00010	<0.00010	<0.00010	<0.00010	<0.00010	<0.00010	<0.00010	<0.00010	<0.00010	0.00093	<0.00010	<0.00010
Copper (Cu)- Dissolved	mg/L	0.087	0.00176	0.00142	0.00055	<0.00020	0.00312	0.00148	0.00091	<0.00020	0.00032	0.00169	0.00064	0.00048
Iron (Fe)- Dissolved	mg/L		0.111	<0.0100	0.159	0.103	0.045	0.010	0.461	0.669	0.588	1.550	0.072	<0.0100
Lead (Pb)- Dissolved	mg/L	0.025	<0.000050	<0.000050	<0.000050	<0.000050	<0.000050	<0.000050	<0.000050	<0.000050	<0.000050	0.000688	<0.000050	<0.000050
Magnesium (Mg)- Dissolved	mg/L		136	195	127	166	252	289	168	182	215	262	160	194
Manganese (Mn)- Dissolved	mg/L		1.21	1.29	0.075	0.074	0.163	0.375	0.315	0.34	1.62	2.14	0.902	0.83
Mercury (Hg)- Total	mg/L	0.0028	0.0000100	<0.000050	0.0000150	<0.000050	0.0004400	0.0003840	0.0001500	0.0000370	0.0007100	0.0003840	0.0000200	<0.000050
Nickel (Ni)- Dissolved	mg/L	0.49	0.00724	0.00802	0.00117	0.00140	0.00442	0.00484	0.00196	0.00204	0.00706	0.01030	0.00511	0.00523
Potassium (K)- Dissolved	mg/L		8.26	8.99	30.9	35.2	14.6	16.5	29.5	31.1	13.4	14.3	9.92	10.7
Selenium (Se)- Dissolved	mg/L	0.063	<0.000050	0.000073	<0.000050	<0.000050	0.000453	0.000324	<0.000050	<0.000050	0.000062	0.000102	<0.000050	0.000072
Silver (Ag)- Dissolved	mg/L	0.0015	<0.000010	0.000020	<0.000010	<0.000010	<0.000010	<0.000010	<0.000010	0.000018	0.000014	0.000018	<0.000010	0.000023
Sodium (Na)- Dissolved	mg/L	2,300	272	363	1,280	1,270	834	786	1,040	1,270	649	597	412	458
Zinc (Zn)- Dissolved	mg/L	1.1	0.0037	0.0031	0.0056	0.0027	0.0057	0.0019	0.0021	<0.0010	0.0046	0.0057	0.0048	0.0032
Field Parameters														
pH	units		7.33	7.21	7.89	7.65	7.70	7.25	8.33	7.70	7.50	7.08	7.41	7.29
Specific Conductivity	(µS/cm)		3,500	4,250	6,880	8,480	4,510	6,770	6,370	9,220	5,200	6,960	4,110	6,250
Polycyclic Aromatic Hydrocarbons														
Naphthalene	mg/L	6.4	<0.000050		<0.000050		<0.000050		<0.000050		<0.000050		<0.000050	
Benzo(a)pyrene	mg/L	0.00081	<0.000005		<0.000005		<0.000005		<0.000005		<0.000005		<0.000005	
Anthracene	mg/L	0.0024	<0.000010		<0.000010		<0.000010		<0.000010		<0.000010		<0.000010	
Petroleum Hydrocarbons														
F1 (C6-C10 Hydrocarbons)	mg/L	0.75	<0.10		<0.10		<0.10		<0.10		<0.10		<0.10	
F2 (C10-C16 Hydrocarbons)	mg/L	0.15	<0.10		<0.10		<0.10		<0.10		<0.10		<0.10	
F3 (C16-C34 Hydrocarbons)	mg/L	0.50	<0.250		<0.250		<0.250		0.890		<0.250		<0.250	
F4 (C34-C50 Hydrocarbons)	mg/L	0.50	<0.250		<0.250		<0.250		0.530		<0.250		<0.250	
Benzene	mg/L	0.43	<0.00050		<0.00050		<0.00050		<0.00050		<0.00050		<0.00050	
EthylBenzene	mg/L	2.3	<0.00050		<0.00050		<0.00050		<0.00050		<0.00050		<0.00050	
Toluene	mg/L	18	<0.00050		<0.00050		<0.00050		<0.00050		<0.00050		<0.00050	
Xylene (Total)	mg/L	4.2	<0.00064		<0.00064		<0.00064		<0.00064		<0.00064		<0.00064	
Volatile Organic Carbons														
Vinyl chloride	mg/L	0.0017	<0.0005		<0.0005		<0.0005		<0.0005		<0.0005		<0.0005	
Pesticides														
Diazinon	µg/L		<0.1000		<0.1000		<0.1000		<0.1000		<0.1000		<0.1000	
Herbicides														
2,4-D	mg/L		<0.0001		<0.0001		<0.0010		<0.0001		<0.0001		<0.0001	

Note: Criteria from Ontario Ministry of the Environment. (2011, July 1). Soil, Ground Water and Sediment Standards for Use Under Part XV.I of the Environmental Protection Act Table 3: Full Depth Generic Site Condition Standards in a Non-Potable Ground Water Condition
 Note: Criteria exceedences are highlighted in red.
 * Criteria for total chloride and total metals

Brady Road Resource Management Facility Annual Report – 2020



**Water and Waste
Eaux et déchets**

Table 2.2 2020 Ground Water Monitoring - Till Wells

			Downgradient and Crossgradient						
			GWQ25-6N63F	GWQ25-6N57F	GWQ25-6N67F	GWQ25-4N34DR	GWQ25-6N58DR	GWQ25-6N58F	GWQ25-6N59F
	Units	Criteria*	Spring	Spring	Spring	Spring	Spring	Spring	Spring
Inorganic Parameters									
Alkalinity - Bicarbonate	mg/L		467	512	606	463	496	479	530
Alkalinity - Carbonate	mg/L		<3.0	<3.0	<3.0	<3.0	<3.0	<3.0	<3.0
Alkalinity - Hydroxide	mg/L		<3.0	<3.0	<3.0	<3.0	<3.0	<3.0	<3.0
Alkalinity - Total	mg/L		467	512	606	463	496	479	530
Dissolved Hardness (CaCO3)	mg/L		1,930	2,160	1,370	1,420	1,800	1,170	1,630
pH	units		6.99	6.99	7.01	7.06	6.77	7.16	6.83
Specific Conductivity	(µS/cm)		6,790	6,190	4,600	6,270	6,620	6,120	6,280
Turbidity	(ntu)		871	2,648	226	492	16.2	402	92.9
Total Dissolved Solids	mg/L		4,570	4,640	3,360	5,510	5,290	4,260	4,820
Total Suspended Solids	mg/L		2,306	1,549	1,420	2,565	418	9,851	1,747
Total Solids	mg/L		6,870	6,180	4,780	8,070	5,700	14,100	6,560
Dissolved Chloride (Cl)	mg/L	2,300	1,550	1,110	740	570	1,010	1,340	980
Dissolved Sulphate (SO4)	mg/L		1,290	1,640	1,240	2,320	2,140	1,220	1,840
Nutrients									
Ammonia - Dissolved	mg/L N		0.932	0.984	0.641	0.469	0.375	1.20	0.092
Nitrate - Dissolved	mg/L N		0.019	0.009	0.099	0.463	0.515	0.082	0.826
Total Kjeldahl Nitrogen	mg/L N		1.3	2.0	1.0	0.9	1.0	1.6	0.4
Phosphorus - Dissolved	mg/L P		0.052	0.025	0.026	0.025	0.031	0.021	0.026
Other									
Cyanide - Total (CN)	mg/L	0.066	<0.0010	<0.0010	<0.0010	<0.0010	<0.0010	<0.0010	<0.0010
Organic Indicators									
Carbonaceous Oxygen Demand	mg/L		74	120	54	50	62	65	51
Total Organic Carbon	mg/L		80.4	197.8	17.9	15.4	45.9	66.4	42.9
Metals									
Arsenic (As)- Dissolved	mg/L	1.9	0.00067	0.00550	0.00147	0.00110	0.00069	0.00198	0.00056
Barium (Ba)- Dissolved	mg/L	29	0.0109	0.0096	0.0118	0.0107	0.0132	0.0138	0.0107
Beryllium (Be)- Dissolved	mg/L	0.067	<0.00010	<0.00010	<0.00010	<0.00010	<0.00010	<0.00010	<0.00010
Cadmium (Cd)- Dissolved	mg/L	0.0027	0.000020	<0.000005	0.000017	0.000022	0.000392	<0.000005	0.000103
Calcium (Ca)- Dissolved	mg/L		441	468	347	448	624	331	580
Chromium (Cr)- Dissolved	mg/L	0.81	<0.00010	<0.00010	<0.00010	<0.00010	<0.00010	<0.00010	0.00010
Copper (Cu)- Dissolved	mg/L	0.087	0.00052	0.00032	0.00085	0.00122	0.00764	<0.00020	0.00211
Iron (Fe)- Dissolved	mg/L		0.273	0.969	0.014	0.082	0.040	0.308	0.059
Lead (Pb)- Dissolved	mg/L	0.025	<0.000050	<0.000050	<0.000050	<0.000050	<0.000050	<0.000050	<0.000050
Magnesium (Mg)- Dissolved	mg/L		273	161	166	383	209	234	190
Manganese (Mn)- Dissolved	mg/L		0.206	0.592	0.031	0.063	3.64	0.075	1.77
Mercury (Hg)- Total	mg/L	0.0028	0.0000200	0.0000620	0.0000150	0.0000170	<0.0000050	0.0000760	0.0000550
Nickel (Ni)- Dissolved	mg/L	0.49	0.00318	0.00542	0.00242	0.00495	0.01190	0.00216	0.00915
Potassium (K)- Dissolved	mg/L		12.1	11.5	8.72	16.4	11.4	11.5	10
Selenium (Se)- Dissolved	mg/L	0.063	0.000133	<0.000050	<0.000050	0.000079	0.000235	<0.000050	0.000071
Silver (Ag)- Dissolved	mg/L	0.0015	0.000013	0.000012	<0.000010	<0.000010	<0.000010	<0.000010	<0.000010
Sodium (Na)- Dissolved	mg/L	2,300	465	429	224	487	391	416	481
Zinc (Zn)- Dissolved	mg/L	1.1	0.0015	0.0034	0.0021	0.0025	0.0082	<0.0010	0.0097
Field Parameters									
pH	units		7.44	7.36	7.43	7.59	7.17	7.72	4.28
Specific Conductivity	(µS/cm)		5,480	4,870	3,710	4,270	5,180	4,920	4,880
Polycyclic Aromatic Hydrocarbons									
Naphthalene	mg/L	6.4				<0.000050			
Benzo(a)pyrene	mg/L	0.00081				<0.000005			
Anthracene	mg/L	0.0024				<0.000010			
Petroleum Hydrocarbons									
F1 (C6-C10 Hydrocarbons)	mg/L	0.75				<0.10			
F2 (C10-C16 Hydrocarbons)	mg/L	0.15				0.13			
F3 (C16-C34 Hydrocarbons)	mg/L	0.50				<0.250			
F4 (C34-C50 Hydrocarbons)	mg/L	0.50				<0.250			
Benzene	mg/L	0.43				<0.00050			
Ethylbenzene	mg/L	2.3				<0.00050			
Toluene	mg/L	18				<0.00050			
Xylene (Total)	mg/L	4.2				<0.00064			
Volatile Organic Carbons									
Vinyl chloride	mg/L	0.0017				<0.0005			
Pesticides									
Diazinon	µg/L					<0.1000			
Herbicides									
2,4-D	mg/L					<0.0001			

Note: Criteria from Ontario Ministry of the Environment. (2011, July 1). Soil, Ground Water and Sediment Standards for Use Under Part XVI of the Environmental Protection Act Table 3: Full Depth Generic Site Condition Standards in a Non-Potable Ground
 Note: Criteria exceedences are highlighted in red.
 * Criteria for total chloride and total metals

Brady Road Resource Management Facility Annual Report – 2020



**Water and Waste
Eaux et déchets**

Table 2.3 2020 Ground Water Monitoring - Bedrock Wells

			Downgradient and Crossgradient											
			GWQ25-W9		GWQ25-W10		GWQ25-W7		GWQ25-W12		GWQ25-W4		GWQ25-W5	
	Units	Criteria*	Spring	Autumn	Spring	Autumn	Spring	Autumn	Spring	Autumn	Spring	Autumn	Spring	Autumn
Inorganic Parameters														
Alkalinity - Bicarbonate	mg/L		141	139	163	149	129	126	134	139	59	57	132	134
Alkalinity - Carbonate	mg/L		<3.0	<3.0	<3.0	<3.0	<3.0	<3.0	<3.0	<3.0	<3.0	<3.0	<3.0	<3.0
Alkalinity - Hydroxide	mg/L		<3.0	<3.0	<3.0	<3.0	<3.0	<3.0	<3.0	<3.0	<3.0	<3.0	<3.0	<3.0
Alkalinity - Total	mg/L		141	139	163	149	129	126	134	139	59	57	132	134
Dissolved Hardness (CaCO3)	mg/L		811	831	779	867	621	680	801	778	558	526	789	769
pH	units		7.48	7.53	7.50	7.55	7.55	7.64	7.57	7.44	7.95	7.79	7.52	7.55
Specific Conductivity	(µS/cm)		9,780	9,230	9,170	8,840	7,100	6,710	8,860	8,360	7,330	7,110	8,260	7,880
Turbidity	(ntu)		3.04	1.17	3.18	23.7	10.8	7.70	6.21	1.43	10.7	13.3	8.26	10.6
Total Dissolved Solids	mg/L		5,800	5,880	5,370	5,590	4,090	4,080	5,350	5,220	4,080	4,120	4,960	5,020
Total Suspended Solids	mg/L		319	317	325	397	394	208	458	341	306	167	488	287
Total Solids	mg/L		6,120	6,200	5,700	5,980	4,490	4,290	5,810	5,560	4,380	4,290	5,440	5,310
Dissolved Chloride (Cl)	mg/L	2,300	2,700	2,680	2,530	2,670	2,020	1,870	2,650	2,640	2,160	1,900	2,210	2,190
Dissolved Sulphate (SO4)	mg/L		918	1,010	808	908	615	660	832	863	522	670	836	870
Nutrients														
Ammonia - Dissolved	mg/L N		1.38	1.36	1.30	1.35	>2.00	>2.00	1.16	1.12	0.805	0.825	1.12	1.03
Nitrate - Dissolved	mg/L N		0.006	0.009	0.003	0.007	<0.003	<0.003	0.005	0.008	0.003	<0.003	<0.003	0.006
Total Kjeldahl Nitrogen	mg/L N		1.3	1.3	1.1	1.3	2.3	2.2	1.1	1.0	0.5	0.7	1.3	1.0
Phosphorus - Dissolved	mg/L P		<0.013	<0.013	<0.013	0.020	0.027	<0.013	<0.013	<0.013	<0.013	<0.013	<0.013	<0.013
Other														
Cyanide - Total (CN)	mg/L	0.066	<0.0010	<0.0010	<0.0010		<0.0010		<0.0010		<0.0010	<0.0010	<0.0010	
Organic Indicators														
Carbonaceous Oxygen Demand	mg/L		89	210	97	250	49	99	78	141	55	100	67	117
Total Organic Carbon	mg/L		0.7	1.5	0.6	1.4	1.4	1.5	1.0	1.2	0.4	0.7	0.9	1.2
Metals														
Arsenic (As)- Dissolved	mg/L	1.9	0.00695	0.01650	0.00522	0.01330	0.00161	0.00263	0.00486	0.01300	0.00496	0.00015	0.00532	0.00487
Barium (Ba)- Dissolved	mg/L	29	0.0111	0.0123	0.0123	0.0152	0.0130	0.0121	0.0129	0.0128	0.0127	0.0097	0.0160	0.0142
Beryllium (Be)- Dissolved	mg/L	0.067	<0.00010	<0.00010	<0.00010	<0.00010	<0.00010	<0.00010	<0.00010	<0.00010	<0.00010	<0.00010	<0.00010	<0.00010
Cadmium (Cd)- Dissolved	mg/L	0.0027	0.000013	<0.000005	<0.000005	<0.000005	<0.000005	0.000006	<0.000005	<0.000005	<0.000005	0.000005	<0.000005	0.000006
Calcium (Ca)- Dissolved	mg/L		336	319	310	306	243	231	305	295	183	166	304	294
Chromium (Cr)- Dissolved	mg/L	0.81	<0.00010	0.00171	<0.00010	<0.00010	<0.00010	0.00014	<0.00010	<0.00010	<0.00010	<0.00010	<0.00010	<0.00010
Copper (Cu)- Dissolved	mg/L	0.087	0.00052	<0.00020	0.00037	<0.00020	<0.00020	0.00064	<0.00020	<0.00020	<0.00020	<0.00020	<0.00020	0.00072
Iron (Fe)- Dissolved	mg/L		0.819	0.982	0.844	1.670	0.282	0.823	0.631	0.626	0.641	1.79	0.678	0.710
Lead (Pb)- Dissolved	mg/L	0.025	<0.000050	<0.000050	<0.000050	<0.000050	<0.000050	<0.000050	<0.000050	<0.000050	<0.000050	<0.000050	<0.000050	<0.000050
Magnesium (Mg)- Dissolved	mg/L		178	185	161	176	99.5	118	190	176	189	97.2	216	171
Manganese (Mn)- Dissolved	mg/L		0.0220	0.0225	0.0155	0.0439	0.0091	0.0094	0.0257	0.0286	0.0255	0.0325	0.0286	0.0259
Mercury (Hg)- Total	mg/L	0.0028	<0.0000050	<0.0000050	<0.0000050	<0.0000050	<0.0000050	<0.0000050	<0.0000050	<0.0000050	<0.0000050	<0.0000050	<0.0000050	<0.0000050
Nickel (Ni)- Dissolved	mg/L	0.49	0.00135	0.00154	0.00133	0.00116	<0.00050	<0.00050	0.00143	0.00135	0.00140	<0.00050	0.00128	0.00127
Potassium (K)- Dissolved	mg/L		42.6	46.2	41.9	46.7	30.6	29.7	40.8	42.5	41.7	29.3	42.1	36.9
Selenium (Se)- Dissolved	mg/L	0.063	<0.000050	<0.000050	<0.000050	<0.000050	<0.000050	<0.000050	<0.000050	0.00006	<0.000050	<0.000050	<0.000050	<0.000050
Silver (Ag)- Dissolved	mg/L	0.0015	0.000093	0.000026	0.000070	<0.000010	<0.000010	0.000016	0.000065	<0.000010	0.000067	<0.000010	0.000065	0.000026
Sodium (Na)- Dissolved	mg/L	2,300	1,610	1,600	1,500	1,490	956	1,060	1,430	1,390	1,220	1,270	1,320	
Zinc (Zn)- Dissolved	mg/L	1.1	0.0014	<0.0010	<0.0010	<0.0010	<0.0010	0.0019	0.0011	<0.0010	0.0010	<0.0010	0.0270	0.0405
Bacteria														
Total Coliforms (MTF)	MPN/100mL		<1	<1	<1	115	<1	<1	<1	1	<1	<1	<1	<1
Fecal Coliforms (MTF)	MPN/100mL		<1	<1	<1	<1	<1	<1	<1	<1	<1	<1	<1	<1
E. coli (MTF)	MPN/100mL		<1	<1	<1	<1	<1	<1	<1	<1	<1	<1	<1	<1
Field Parameters														
pH	units		7.86	7.90	7.89	7.85	8.50	8.16	7.98	7.94	8.90	8.43	8.01	7.96
Specific Conductivity	(µS/cm)		7,320	9,470	7,000	9,390	5,540	7,270	6,950	8,780	5,650	6,390	6,700	8,510
Polycyclic Aromatic Hydrocarbons														
Naphthalene	mg/L	6.4	<0.000050	<0.000050	<0.000050		<0.000050		<0.000050		<0.000050	<0.000050	<0.000050	
Benzo(a)pyrene	mg/L	0.00081	<0.000005	<0.000005	<0.000005		<0.000005		<0.000005		<0.000005	<0.000005	<0.000005	
Anthracene	mg/L	0.0024	<0.000010	<0.000010	<0.000010		<0.000010		<0.000010		<0.000010	<0.000010	<0.000010	
Petroleum Hydrocarbons														
F1 (C6-C10 Hydrocarbons)	mg/L	0.75	<0.10	<0.10	<0.10		<0.10		<0.10		<0.10	<0.10	<0.10	
F2 (C10-C16 Hydrocarbons)	mg/L	0.15	<0.10	<0.10	<0.10		<0.10		<0.10		<0.10	<0.10	<0.10	
F3 (C16-C34 Hydrocarbons)	mg/L	0.50	<0.250	<0.250	<0.250		<0.250		<0.250		<0.250	<0.250	<0.250	
F4 (C34-C50 Hydrocarbons)	mg/L	0.50	<0.250	<0.250	<0.250		<0.250		<0.250		<0.250	<0.250	<0.250	
Benzene	mg/L	0.43	<0.00050	<0.00050	<0.00050		<0.00050		<0.00050		<0.00050	<0.00050	<0.00050	
EthylBenzene	mg/L	2.3	<0.00050	<0.00050	<0.00050		<0.00050		<0.00050		<0.00050	<0.00050	<0.00050	
Toluene	mg/L	18	<0.00050	<0.00050	<0.00050		<0.00050		<0.00050		<0.00050	<0.00050	<0.00050	
Xylene (Total)	mg/L	4.2	<0.00064	<0.00064	<0.00064		<0.00064		<0.00064		<0.00064	<0.00064	<0.00064	
Volatile Organic Carbons														
Vinyl chloride	mg/L	0.0017	<0.0005	<0.0005	<0.0005		<0.0005		<0.0005		<0.0005	<0.0005	<0.0005	
Pesticides														
Diazinon	µg/L		<0.1000	<0.1000	<0.1000		<0.1000		<0.1000		<0.1000	<0.1000	<0.1000	
Herbicides														
2,4-D	mg/L		<0.0001	<0.0001	<0.0001		<0.0001		<0.0010		<0.0010	<0.0001	<0.0010	

Note: Criteria from Ontario Ministry of the Environment. (2011, July 1). Soil, Ground Water and Sediment Standards for Use Under Part XV.I of the Environmental Protection Act Table 3: Full Depth Generic Site Condition Standards in a Non-Potable Ground Water Condition
 Note: Criteria exceedances are highlighted in red.
 * Criteria for total chloride and total metals

Brady Road Resource Management Facility Annual Report – 2020



**Water and Waste
Eaux et déchets**

Table 3.1 2020 Ground Water Quality Comparison - Clay Wells

Parameter	Units	Criteria	2014		2015		2016		2017		2018		2019		2020	
			Average		Average		Average		Average		Average		Average		Average	
			Upgradient	Downgradient	Upgradient	Downgradient	Upgradient	Downgradient	Upgradient	Downgradient	Upgradient	Downgradient	Upgradient	Downgradient	Upgradient	Downgradient
Inorganic Parameters																
Alkalinity - Bicarbonate	mg/L		582	584	548	574	625	642	621	603	539	585	530	546	528	555
Alkalinity - Carbonate	mg/L		<-0.50	<-0.50	<-0.50	<-0.50	<-0.50	<-0.50	<-0.50	<-0.50	<-0.50	<-0.50	<-0.50	<-0.50	<-0.50	<-0.50
Alkalinity - Hydroxide	mg/L		<-0.50	<-0.50	<-0.50	<-0.50	<-0.50	<-0.50	<-0.50	<-0.50	<-0.50	<-0.50	<-0.50	<-0.50	<-0.50	<-0.50
Alkalinity - Total	mg/L		477	509	449	471	512	526	509	495	539	585	530	546	528	555
Dissolved Hardness (CaCO3)	mg/L		2,110	2,747	2,640	3,012	2,260	2,666	2,120	2,558	2,325	3,065	1,720	2,202	1,370	1,777
pH	units		8.23	7.91	6.96	7.07	6.96	6.97	7.04	6.97	6.81	6.80	6.98	6.81	6.91	6.91
Specific Conductivity	(µS/cm)		4,590	6,128	4,390	5,830	4,560	5,996	4,780	6,386	4,820	6,462	4,800	6,622	4,820	6,523
Turbidity	(ntu)		370.0	249.8	23.8	37.9	40.4	504.2	91.8	6462.5	116.0	555.4	24.3	42.2	122.0	329.5
Total Dissolved Solids	mg/L		4,500	5,935	4,060	4,918	3,960	4,967	3,840	4,720	3,890	5,076	3,880	6,783	3,960	5,376
Total Suspended Solids	mg/L		1,480	430	160	325	310	1,247	500	8,842	280	1,357	268	970	183	1,143
Total Solids	mg/L		5,980	6,365	4,220	5,243	4,270	6,214	4,340	13,562	4,170	6,433	4,150	7,753	4,140	6,516
Dissolved Chloride (Cl)	mg/L	2,300 *	460	965	440	918	450	927	470	990	474	948	570	1,067	369	1,057
Dissolved Sulphate (SO4)	mg/L		1,680	1,938	1,710	1,845	2,000	1,959	1,670	1,738	1,750	1,911	1,730	2,160	1,680	2,110
Nutrients																
Ammonia - Dissolved	mg/L N		0.250	0.467	<-0.003	0.268	<-0.003	0.156	0.175	0.584	0.129	0.646	0.005	0.356	0.012	0.362
Nitrate - Dissolved	mg/L N		1.570	0.772	1.350	0.653	13.0	0.680	0.630	0.426	0.635	0.337	0.855	0.356	0.923	0.408
Total Kjeldahl Nitrogen	mg/L N		2.1	2.7	0.5	1.2	2.0	1.6	0.7	1.2	0.9	0.2	0.9	0.2	1.2	
Phosphorus - Dissolved	mg/L P		0.700 **	0.267 **	0.020	0.026	0.180	0.012	<-0.010	0.020	<-0.010	<-0.010	<-0.010	0.017	0.027	0.027
Other																
Cyanide - Total (CN)	mg/L	0.066	NA	NA	0.00052	NR	NR	NR	NR	NR	NR	NR	<-0.0010	<-0.0010	<-0.0010	<-0.0010
Organic Indicators																
Chemical Oxygen Demand	mg/L		NA	NA	32	70	44	122	50	792	40	69	32	156	47	97
Total Organic Carbon	mg/L		24.0	45.0	12.0	16.5	10.6	22.0	10.8	19.6	29.1	17.7	10.0	23.0	9.9	37.7
Metals																
Arsenic (As) - Dissolved	mg/L	1.9 *	0.000370	0.000553	0.000420	0.000730	0.000394	0.000730	0.000360	0.000722	0.000530	0.000796	0.000480	0.000758	0.000480	0.000876
Barium (Ba) - Dissolved	mg/L	29 *	0.00950	0.01188	0.01280	<-0.01390	<-0.00968	0.01252	0.00869	0.01179	0.00870	0.01326	0.00810	0.01083	0.0087	0.01166
Beryllium (Be) - Dissolved	mg/L	0.067 *	<-0.00010	<-0.00010	<-0.00010	<-0.00010	0.000015	0.000008	<-0.00010	<-0.00010	<-0.00010	<-0.00010	<-0.00010	<-0.00010	<-0.00010	<-0.00010
Cadmium (Cd) - Dissolved	mg/L	0.0027 *	0.000081	0.000145	0.000143	0.000125	0.000068	0.000181	0.000052	0.000216	0.000215	0.000211	0.000047	0.000155	0.000026	0.000141
Calcium (Ca) - Dissolved	mg/L		536	653	700	572	646	540	637	575	713	579	697	405	597	
Chromium (Cr) - Dissolved	mg/L	0.81 *	<-0.0010	<-0.0010	<-0.00010	<-0.00010	<-0.00010	0.00008	<-0.0010	<-0.0010	0.00013	0.00043	<-0.00010	0.00011	<-0.00010	<-0.00010
Copper (Cu) - Dissolved	mg/L	0.087 *	0.0017	0.0034	0.0032	0.0031	0.0027	0.0027	0.0016	0.0023	0.0021	0.0086	0.0014	0.0021	0.00187	0.0028
Iron (Fe) - Dissolved	mg/L		0.016	0.015	0.003	0.008	0.004	0.014	0.023	0.091	<-0.010	0.115	<-0.010	0.058	0.016	0.011
Lead (Pb) - Dissolved	mg/L	0.025 *	0.000084	0.000054	0.000037	<-0.000058	0.000037	<-0.000053	0.000103	0.000098	<-0.000050	0.000343	<-0.000050	<-0.000050	<-0.000050	<-0.000050
Magnesium (Mg) - Dissolved	mg/L		187	271	128	297	201	256	187	235	216	312	212	334	160	285
Manganese (Mn) - Dissolved	mg/L		1.55	1.55	1.58	1.58	1.72	1.59	1.87	1.86	2.03	0.86	1.54	1.10	1.47	
Mercury (Hg) - Total	mg/L	0.0028	NA	NA	<-0.000010	<-0.000010	<-0.000010	<-0.000002	<-0.000002	<-0.000005	0.0000612	<-0.0000050	0.0000710	<-0.0000050	0.000680	
Nickel (Ni) - Dissolved	mg/L	0.49 *	0.00660	0.00999	0.00700	0.01030	0.00698	0.00950	0.00643	0.00992	0.00724	0.01277	0.00667	0.00972	0.00640	0.00925
Potassium (K) - Dissolved	mg/L		9.7	11.0	11.0	11.4	9.7	10.9	9.2	10.9	14.0	11.4	10.2	9.8	10.7	
Selenium (Se) - Dissolved	mg/L	0.063 *	<-0.00040	0.00084	0.00016	0.00032	0.00018	0.00027	<-0.00040	<-0.00040	0.00013	0.00023	0.00014	0.01189	0.000069	0.00048
Silver (Ag) - Dissolved	mg/L	0.0015 *	<-0.000050	<-0.000050	<-0.000005	0.000006	<-0.000005	<-0.000005	<-0.000005	<-0.000005	<-0.000010	<-0.000010	0.000010	0.000020	<-0.000010	<-0.000010
Sodium (Na) - Dissolved	mg/L	2,300 *	353	554	362	555	336	485	325	534	345	582	332	550	267	415
Zinc (Zn) - Dissolved	mg/L	1.1 *	0.00410	0.00877	0.00790	0.00810	0.00359	0.00572	0.00550	0.00766	0.00620	0.01546	0.00450	0.00547	0.00640	0.00611
Field Parameters																
pH	units		NA	NA	7.42	6.66	7.36	7.38	7.84	7.78	7.02	7.19	7.44	7.67	7.44	7.34
Specific Conductivity	(µS/cm)		NA	NA	4,230	6,793	2,330	3,271	4,010	5,248	4,330	5,986	4,050	5,295	4,050	5,010
Polycyclic Aromatic Hydrocarbons																
Naphthalene	mg/L	6.4	NA	<-0.000050	NR	<-0.000050	<-0.000050	NR	NR	NR	<-0.000050	<-0.000050	<-0.000050	<-0.000050	<-0.000050	<-0.000050
Benzo(a)pyrene	mg/L	0.00081	NA	<-0.000010	NR	<-0.000010	<-0.000010	NR	NR	NR	<-0.000050	<-0.000050	<-0.000050	<-0.000050	<-0.000050	<-0.000050
Anthracene	mg/L	0.0024	NA	<-0.000050	NR	<-0.000050	<-0.000050	NR	NR	NR	<-0.000010	<-0.000010	<-0.000010	<-0.000010	<-0.000010	<-0.000010
Petroleum Hydrocarbons																
F1 (C6-C10 Hydrocarbons)	mg/L	0.75	<-0.025	<-0.025	NR	NR	<-0.025	NR	<-0.025	NR	<-0.10	<-0.10	<-0.10	<-0.10	<-0.10	<-0.10
F2 (C10-C16 Hydrocarbons)	mg/L	0.15	<-0.10	<-0.10	NR	NR	<-0.10	NR	<-0.10	NR	<-0.10	<-0.10	<-0.10	<-0.10	<-0.10	<-0.10
F3 (C16-C34 Hydrocarbons)	mg/L	0.50	<-0.20	<-0.20	NR	NR	<-0.20	NR	<-0.20	NR	<-0.25	<-0.25	<-0.25	<-0.25	<-0.25	<-0.25
F4 (C34-C50 Hydrocarbons)	mg/L	0.50	<-0.20	<-0.20	NR	NR	<-0.20	NR	<-0.20	NR	<-0.25	<-0.25	<-0.25	<-0.25	<-0.25	<-0.25
Benzene	mg/L	0.43	<-0.00010	<-0.00010	NR	NR	<-0.00010	NR	<-0.00010	NR	<-0.00050	<-0.00050	<-0.00050	<-0.00050	<-0.00050	<-0.00050
Ethylbenzene	mg/L	2.3	<-0.00010	<-0.00010	NR	NR	<-0.00010	NR	<-0.00010	NR	<-0.00050	<-0.00050	<-0.00050	<-0.00050	<-0.00050	<-0.00050
Toluene	mg/L	18	<-0.00020	<-0.00020	NR	NR	<-0.00020	NR	<-0.00020	NR	<-0.00050	<-0.00050	<-0.00050	<-0.00050	<-0.00050	<-0.00050
Xylene (Total)	mg/L	4.2 *	<-0.00010	<-0.00010	NR	NR	<-0.00010	NR	<-0.00010	NR	<-0.00050	<-0.00050	<-0.00050	<-0.00050	<-0.00050	<-0.00050
Volatile Organic Carbons																
Vinyl chloride	mg/L	1.7	<-0.0002	<-0.0002	NR	NR	<-0.0002	NR	<-0.0002	NR	<-0.0005	<-0.0005	<-0.0005	<-0.0005	<-0.0005	<-0.0005
Pesticides																
Diazinon	µg/L		NA	NA	NR	NR	<2.0	NR	<2.0	NR	<-0.10	<-0.10	<-0.10	<-0.10	<-0.10	<-0.10
Herbicides																
2,4-D	mg/L		NA	NA	NR	NR	<-0.0010	NR	<-0.0010	NR	<-0.00010	<-0.00010	<-0.00010	<-0.00010	<-0.00010	<-0.00010

Note: Criteria from Ontario Ministry of the Environment. (2011, July 1). Soil, Ground Water and Sediment Standards for Use Under Part XVI.I of the Environmental Protection Act Table 3: Full Depth Generic Site Condition Standards in a Non-Potable Ground Water Condition

Note: Where value is expressed as less than (<), the value is halved and used in the calculations, where value is expressed as (>), the value is used in the calculations.

* Criteria for total chloride, total metals and xylene mixture

** Total phosphorus results, dissolved phosphorus not analysed

NR - No result due to lab error.

Client File No. 5556.00

Manitoba Environment Act Licence No. 3081 R

Brady Road Resource Management Facility Annual Report – 2020

		Table 3.2 2020 Ground Water Quality Comparison - Till Wells														
	Units	Criteria	2014		2015		2016		2017		2018		2019		2020	
			Average		Average		Average		Average		Average		Average		Average	
			Upgradient	Downgradient	Upgradient	Downgradient	Upgradient	Downgradient	Upgradient	Downgradient	Upgradient	Downgradient	Upgradient	Downgradient	Upgradient	Downgradient
Inorganic Parameters																
Alkalinity - Bicarbonate	mg/L		533	344	570	333	667	399	663	366	683	536	604	1,007	572	554
Alkalinity - Carbonate	mg/L		<-0.50	<-0.50	<-0.50	<-0.50	<-0.50	<-0.50	<-0.50	<-0.50	<-0.50	<-0.50	<-0.50	<-0.50	<-0.50	<-0.50
Alkalinity - Hydroxide	mg/L		<-0.50	<-0.50	<-0.50	<-0.50	<-0.50	<-0.50	<-0.50	<-0.50	<-0.50	<-0.50	<-0.50	<-0.50	<-0.50	<-0.50
Alkalinity - Total	mg/L		437	282	467	273	547	327	544	300	683	536	604	1,007	572	554
Dissolved Hardness (CaCO ₃)	mg/L		1,660	2,482	1,625	2,305	1,580	1,977	1,550	2,001	1,853	2,415	1,510	3,436	1,240	2,435
pH			7.74	7.72	7.32	6.97	7.21	6.92	7.11	6.96	7.11	6.93	7.12	6.95	7.13	
Specific Conductivity	(µS/cm)		3,670	6,396	4,030	6,212	4,380	6,814	4,300	7,027	4,280	6,888	4,270	7,049	4,080	6,694
Turbidity	(ntu)		62.2	3,194	952	5,051	209	3,110	183	4,259	215	5,126	247	3,338	186	1,636
Total Dissolved Solids	mg/L		3,160	5,607	3,620	5,056	3,470	4,703	3,260	4,774	3,345	4,715	3,300	4,297	3,285	4,318
Total Suspended Solids	mg/L		2,120	10,188	2,050	13,039	610	11,186	640	9,840	616	7,528	880	9,199	581	7,044
Total Solids	mg/L		5,280	15,795	5,670	18,095	4,080	15,889	3,900	14,614	3,958	12,245	4,180	12,768	3,865	11,355
Dissolved Chloride (Cl)	mg/L	2,300 *	480	1,519	425	1,421	380	1,465	390	1,562	398	1,518	436	1,643	405	1,415
Dissolved Sulphate (SO ₄)	mg/L		1,020	1,218	1,410	1,256	1,450	1,343	1,430	1,258	1,465	1,308	1,375	1,101	1,405	1,500
Nutrients																
Ammonia - Dissolved	mg/L N		0.870	0.940	0.552	0.855	0.161	0.709	0.304	0.845	0.496	0.892	0.386	0.859	0.198	0.758
Nitrate - Dissolved	mg/L N		0.040	0.159	0.112	0.048	0.445	0.257	0.371	0.086	0.231	0.086	0.206	0.048	0.588	0.189
Total Kjeldahl Nitrogen	mg/L N		1.4	4.5	1.4	4.0	1.0	3.0	0.8	1.6	0.9	1.4	0.7	1.5	0.3	1.3
Phosphorus - Dissolved	mg/L P		0.800 **	2.883 **	0.025	0.036	0.030	0.036	<0.010	0.022	0.012	0.018	<0.013	0.013	0.023	0.030
Other																
Cyanide - Total (CN)	mg/L	0.066	NA	NA	0.00083	0.00072	<0.00050	<0.00050	<0.00050	<0.00050	<0.00050	<0.00050	<0.00050	<0.00050	<0.00050	<0.00050
Organic Indicators																
Chemical Oxygen Demand	mg/L		NA	NA	54	262	45	259	40	286	25	504	43	354	43	252
Total Organic Carbon	mg/L		11.0	162.0	56.5	71.0	9.2	39.6	10.0	31.1	19.9	32.3	9.4	18.1	8.4	47.0
Metals																
Arsenic (As) - Dissolved	mg/L	1.9*	0.002190	0.002798	0.002250	0.003300	0.002480	0.001978	0.001210	0.002620	0.001190	0.002578	0.001110	0.003034	0.000975	0.001805
Barium (Ba) - Dissolved	mg/L	29*	0.02450	0.02208	0.01230	0.01560	0.00915	0.01146	0.00809	0.01497	0.00827	0.01380	0.00804	0.01161	0.00840	0.01268
Beryllium (Be) - Dissolved	mg/L	0.067*	<0.00020	0.000208	<0.00010	<0.00010	0.000014	<0.00010	<0.00010	<0.00010	<0.00010	<0.00010	<0.00010	<0.00010	<0.00010	<0.00010
Cadmium (Cd) - Dissolved	mg/L	0.0027*	<0.00010	0.000191	0.000052	0.000180	0.000058	0.000076	<0.000050	0.000070	0.000037	0.000076	0.000057	0.000033	0.000022	0.000050
Calcium (Ca) - Dissolved	mg/L		357	601	386	527	376	457	574	457	544	432	544	432	473	473
Chromium (Cr) - Dissolved	mg/L	0.81*	<0.0020	<0.0020	<0.00010	<0.00010	0.00030	<0.0010	<0.0010	0.00130	<0.00010	0.00051	<0.00010	<0.00010	<0.00010	0.00010
Copper (Cu) - Dissolved	mg/L	0.087*	0.0021	0.0028	0.0020	0.0012	0.00028	0.0019	0.0019	0.0037	0.0019	0.0023	0.0014	0.0002	0.0016	0.0013
Iron (Fe) - Dissolved	mg/L		<0.020	1.700	0.015	0.413	0.006	0.166	0.194	0.884	<0.010	0.662	0.022	0.530	0.058	0.318
Lead (Pb) - Dissolved	mg/L	0.025*	0.000170	0.002850	0.000027	<0.000039	0.000059	<0.000050	0.000060	0.000530	<0.000050	0.000060	<0.000050	<0.000050	<0.000050	0.000064
Magnesium (Mg) - Dissolved	mg/L		187	247	161	240	155	201	154	210	171	257	195	231	166	214
Manganese (Mn) - Dissolved	mg/L		0.25	0.92	0.52	0.65	0.77	0.55	0.87	1.09	0.88	1.17	0.55	1.25	0.78	0.78
Mercury (Hg) - Total	mg/L	0.0028	NA	NA	<0.00010	<0.00010	<0.000010	<0.000010	<0.000020	0.0000280	<0.000005	0.0000258	0.0000190	0.0000650	0.0001407	0.0001407
Nickel (Ni) - Dissolved	mg/L	0.49*	0.00954	0.00943	0.00730	0.00480	0.00737	0.00404	0.00759	0.00462	0.00731	0.00545	0.00791	0.00418	0.00763	0.00487
Potassium (K) - Dissolved	mg/L		15.7	16.6	9.7	16.3	8.2	14.8	7.5	17.6	9.0	19.6	8.6	19.6	8.6	16.9
Selenium (Se) - Dissolved	mg/L	0.063*	<0.00080	<0.00040	0.00024	0.00016	0.00012	<0.00040	<0.00040	<0.00040	<0.00040	0.00007	0.00008	0.00025	<0.000050	0.00010
Silver (Ag) - Dissolved	mg/L	0.0015*	<0.00010	<0.000050	<0.000005	<0.000005	<0.000005	<0.000005	<0.000005	<0.000005	<0.000010	<0.000010	0.000015	0.000021	0.000013	<0.000010
Sodium (Na) - Dissolved	mg/L	2,300*	313	716	581	745	521	651	422	772	396	784	371	835	318	676
Zinc (Zn) - Dissolved	mg/L	1.1*	0.00250	0.01463	0.00550	0.00600	0.00388	0.00717	0.00550	0.00602	0.00630	0.00795	0.00360	0.00250	0.00340	0.00380
Field Parameters																
pH	units		NA	NA	7.53	6.98	7.35	7.50	7.85	7.93	7.26	7.37	7.59	7.80	7.27	7.34
Specific Conductivity	(µS/cm)		NA	NA	3,028	4,642	3,190	3,147	3,790	6,481	3,630	6,295	4,650	5,581	3,875	5,768
Polycyclic Aromatic Hydrocarbons																
Naphthalene	mg/L	6.4	NA	<0.000050	<0.000050	<0.000050	<0.000050	<0.000050	NR	NR	<0.000050	<0.000050	<0.000050	<0.000050	<0.000050	<0.000050
Benzo(a)pyrene	mg/L	0.00081	NA	<0.000010	<0.000010	<0.000010	<0.000010	<0.000010	NR	NR	<0.000050	<0.000050	<0.000050	<0.000050	<0.000050	<0.000050
Anthracene	mg/L	0.0024	NA	<0.000050	<0.000050	<0.000050	<0.000050	<0.000050	NR	NR	<0.000010	<0.000010	<0.000010	<0.000010	<0.000010	<0.000010
Petroleum Hydrocarbons																
F1 (C6-C10 Hydrocarbons)	mg/L	0.75	NA	<-0.025	<-0.025	<-0.025	<-0.025	<-0.025	<-0.025	<-0.025	<-0.10	<-0.10	<-0.10	<-0.10	<-0.10	<-0.10
F2 (C10-C16 Hydrocarbons)	mg/L	0.15	NA	<-0.10	<-0.10	<-0.10	<-0.10	<-0.10	<-0.10	<-0.10	<-0.10	<-0.10	<-0.10	<-0.10	<-0.10	<-0.10
F3 (C16-C34 Hydrocarbons)	mg/L	0.50	NA	<-0.20	<-0.20	<-0.20	<-0.20	<-0.20	<-0.20	<-0.20	<-0.25	<-0.25	<-0.25	<-0.25	<-0.25	<-0.25
F4 (C34-C50 Hydrocarbons)	mg/L	0.50	NA	<-0.20	<-0.20	<-0.20	<-0.20	<-0.20	<-0.20	<-0.20	<-0.25	<-0.25	<-0.25	<-0.25	<-0.25	<-0.25
Benzene	mg/L	0.43	NA	<0.00010	<0.00010	<0.00010	<0.00010	<0.00010	<0.00010	<0.00010	<0.00050	<0.00050	<0.00050	<0.00050	<0.00050	<0.00050
Ethylbenzene	mg/L	2.3	NA	<0.00010	<0.00010	<0.00010	<0.00010	<0.00010	<0.00010	<0.00010	<0.00050	<0.00050	<0.00050	<0.00050	<0.00050	<0.00050
Toluene	mg/L	18	NA	<0.00020	<0.00020	<0.00020	<0.00020	<0.00020	<0.00020	<0.00020	<0.00050	<0.00050	<0.00050	<0.00050	<0.00050	<0.00050
Xylene (Total)	mg/L	4.2*	NA	<0.00010	<0.00010	<0.00010	<0.00010	<0.00010	<0.00010	0.00037	<0.00050	<0.00050	<0.00050	<0.00050	<0.00064	<0.00064
Volatile Organic Carbons																
Vinyl chloride	mg/L	1.7	NA	<0.0002	<0.0002	<0.0002	<0.0002	<0.0002	<0.0002	<0.0002	<0.0005	<0.0005	<0.0005	<0.0005	<0.0005	<0.0005
Pesticides																
Diazinon	µg/L		NA	NA	<2.0	<2.0	<2.0	<2.0	<2.0	<2.0	<2.0	<2.0	<2.0	<2.0	<2.0	<2.0
Herbicides																
2,4-D	mg/L		NA	NA	<0.0010	<0.0010	<0.0010	<0.0010	<0.0010	<0.0010	<0.0010	<0.0010	<0.0010	<0.0010	<0.0010	<0.0010

Note: Criteria from Ontario Ministry of the Environment. (2011, July 1). Soil, Ground Water and Sediment Standards for Use Under Part XVI of the Environmental Protection Act Table 3: Full Depth Generic Site Condition Standards in a Non-Potable Ground Water Condition

Note: Where value is expressed as less than (<), the value is halved and used in the calculations, where value is expressed as (>), the value is used in the calculations.

* Criteria for total chloride, total metals and xylene mixture

** Total phosphorus results, dissolved phosphorus not analysed

NR - No result due to lab error.

Brady Road Resource Management Facility Annual Report – 2020



Table 3.3 2020 Ground Water Quality Comparison - Bedrock Wells

Parameters	Units	Criteria	2014		2015		2016		2017		2018		2019		2020	
			Average		Average		Average		Average		Average		Average		Average	
			Upgradient	Downgradient	Upgradient	Downgradient	Upgradient	Downgradient	Upgradient	Downgradient	Upgradient	Downgradient	Upgradient	Downgradient	Upgradient	Downgradient
Inorganic Parameters																
Alkalinity - Bicarbonate	mg/L		160	146	153	153	164	166	164	162	1,454	136	150	154	141	138
Alkalinity - Carbonate	mg/L		<-0.50	<-0.50	<-0.50	<-0.50	<-0.50	<-0.50	<-0.50	<-0.50	<3.0	5.0	<-3.0	<-3.0	<-3.0	<-3.0
Alkalinity - Hydroxide	mg/L		<-0.50	<-0.50	<-0.50	<-0.50	<-0.50	<-0.50	<-0.50	<-0.50	<3.0	17.0	<-3.0	<-3.0	<-3.0	<-3.0
Alkalinity - Total	mg/L		131	120	126	125	134	136	134	133	1,454	155	150	154	141	138
Dissolved Hardness (CaCO3)	mg/L		1,440	1,478	1,630	1,396	1,065	1,237	1,390	1,200	1,544	1,523	998	872	819	811
pH	units		7.99	7.80	7.46	7.64	7.56	7.42	7.49	7.54	7.67	7.58	7.51	7.47	7.57	7.57
Specific Conductivity	(µS/cm)		9,700	7,988	9,980	8,206	10,250	8,484	9,865	8,373	10,025	8,255	10,100	8,433	10,105	8,262
Turbidity	(ntu)		8.5	116.1	13.5	75.5	15.4	38.9	10.0	26.1	7.6	13.3	6.8	12.4	11.6	8.0
Total Dissolved Solids	mg/L		6,780	5,743	6,740	5,503	6,265	5,033	6,145	5,020	6,320	5,043	6,220	4,989	6,245	5,032
Total Suspended Solids	mg/L		335	627	40	300	320	426	640	590	383	416	401	475	359	334
Total Solids	mg/L		7,115	6,370	6,780	5,802	6,585	5,458	6,785	5,611	6,703	5,459	6,625	5,463	6,610	5,366
Dissolved Chloride (Cl)	mg/L	2,300 *	2,070	1,748	2,950	2,292	3,000	2,413	2,850	2,208	2,785	2,131	1,855	2,281	2,800	2,393
Dissolved Sulphate (SO4)	mg/L		929	756	942	748	974	759	943	765	941	747	833	680	949	882
Nutrients																
Ammonia - Dissolved	mg/L N		1.25	2.17	1.30	0.95	1.31	1.06	1.36	1.10	0.686	1.09	1.44	1.11	1.43	1.12
Nitrate - Dissolved	mg/L N		0.009	0.008	0.007	0.009	0.012	0.025	<-0.003	0.011	0.631	0.046	<-0.003	0.035	0.010	0.005
Total Kjeldahl Nitrogen	mg/L N		3.2	3.0	2.9	2.9	2.0	1.6	1.6	1.1	2.0	1.2	1.5	1.7	1.1	1.1
Phosphorus - Dissolved	mg/L P		<-0.20 **	0.242 **	0.030	0.020	0.018	<-0.010	<-0.010	<-0.010	0.015	<-0.010	<-0.013	<-0.013	<-0.013	<-0.013
Other																
Cyanide - Total (CN)	mg/L	0.066	<-0.00050	<-0.00050	<-0.00050	<-0.00050	<-0.00050	<-0.00050	<-0.00050	<-0.00050	<-0.0010	<-0.0050	<-0.0010	<-0.0010	0.0011	<-0.0010
Organic Indicators																
Chemical Oxygen Demand	mg/L		NA	NA	218	108	111	102	90	75	80	59	118	81	177	115
Total Organic Carbon	mg/L		4.5	7.4	2.5	7.1	3.5	2.1	3.7	3.2	3.4	2.6	1.9	2.3	1.5	1.1
Metals																
Arsenic (As) - Dissolved	mg/L	1.9*	0.005260	0.004122	0.006250	0.003650	0.001508	0.002834	0.002915	0.003750	0.003140	0.004048	0.000865	0.003519	0.005830	0.006633
Barium (Ba) - Dissolved	mg/L	29*	0.01305	0.03051	0.01530	0.02260	0.01019	0.01730	0.01400	0.01874	0.01265	0.01900	0.01490	0.02337	0.01250	0.01287
Beryllium (Be) - Dissolved	mg/L	0.067*	<-0.00010	<-0.00010	<-0.00010	<-0.00010	<-0.00010	<-0.00010	<-0.00010	<-0.00010	<-0.00010	<-0.00010	<-0.00010	<-0.010	<-0.00010	<-0.00010
Cadmium (Cd) - Dissolved	mg/L	0.0027*	<-0.000050	<-0.000050	0.000017	0.000022	0.000050	0.000014	0.000024	0.000058	0.000090	0.000052	0.000140	0.000130	0.000006	<-0.000005
Calcium (Ca) - Dissolved	mg/L		331	389	333	379	345	303	312	282	340	332	315	326	315	326
Chromium (Cr) - Dissolved	mg/L	0.81*	<-0.0010	0.00394	<-0.00010	0.00466	0.00021	0.00454	<-0.0010	0.00360	0.00064	0.00375	0.00052	0.00645	<-0.00010	0.00012
Copper (Cu) - Dissolved	mg/L	0.087*	0.0013	0.0008	0.0012	0.0007	0.0004	0.0029	0.0032	0.0013	0.0017	0.0036	0.0042	<-0.0002	0.0003	0.0003
Iron (Fe) - Dissolved	mg/L		1.335	1.990	1.400	0.569	0.084	0.338	0.633	0.648	0.673	0.786	<-0.010	0.516	1.305	0.750
Lead (Pb) - Dissolved	mg/L	0.025*	0.000579	0.000125	0.000216	0.000050	0.000016	0.000034	0.000125	0.000079	0.000106	0.000163	0.000094	0.000186	0.000152	<-0.000050
Magnesium (Mg) - Dissolved	mg/L		158	133	167	127	112	128	149	120	169	180	166	129	151	163
Manganese (Mn) - Dissolved	mg/L		0.03	0.10	0.03	0.03	0.03	0.02	0.03	0.03	0.03	0.03	0.03	0.03	0.03	0.03
Mercury (Hg) - Total	mg/L		NA	NA	<-0.00010	<-0.00010	<-0.00010	<-0.00010	<-0.00010	<-0.00010	<-0.00010	<-0.00010	<-0.00010	<-0.00010	<-0.00010	<-0.00010
Nickel (Ni) - Dissolved	mg/L	0.49*	0.00204	0.00180	0.00160	0.00120	0.00129	0.00131	0.00200	0.00145	0.00203	0.00176	0.00289	0.00280	0.00136	0.00119
Potassium (K) - Dissolved	mg/L		44.2	34.5	44.8	32.0	31.0	28.7	41.0	28.6	34.1	34.1	30.8	46.6	36.9	36.9
Selenium (Se) - Dissolved	mg/L	0.063*	<-0.00040	<-0.00040	<-0.00004	0.00009	<-0.00020	<-0.00040	<-0.00040	<-0.00040	<-0.00050	0.00011	<-0.00050	0.00036	<-0.00050	<-0.00050
Silver (Ag) - Dissolved	mg/L	0.0015*	<-0.000050	<-0.000050	<-0.00005	<-0.000025	<-0.000050	<-0.000050	<-0.000050	<-0.000050	<-0.000050	<-0.000050	0.000014	0.000036	0.000020	0.000028
Sodium (Na) - Dissolved	mg/L	2,300*	1,695	1,181	1,755	1,195	1,140	1,074	1,590	1,126	1,750	1,238	1,750	1,129	1,645	1,306
Zinc (Zn) - Dissolved	mg/L	1.1*	0.00735	0.00950	0.02260	0.01250	0.01309	0.00914	0.03980	0.00980	0.01450	0.01103	0.05180	0.01720	0.00465	0.00400
Bacteria																
Total Coliforms (MTF)	MPN/100mL		<3	8	<3	128	12	23	<3	<3	<1	21	<1	2	<1	5
Fecal Coliforms (MTF)	MPN/100mL		<3	<3	<3	16	<3	<3	<3	<3	<1	1	<1	<1	<1	<1
E. coli (MTF)	MPN/100mL		<3	<3	<3	16	<3	<3	<3	<3	<1	<1	<1	<1	<1	<1
Field Parameters																
pH	units		NA	NA	7.09	7.61	7.87	7.73	8.34	8.31	7.30	7.96	7.77	7.78	8.16	8.09
Specific Conductivity	(µS/cm)		NA	NA	6,754	5,534	5,017	5,073	8,015	7,812	9,140	6,836	8,215	6,961	9,185	7,403
Polycyclic Aromatic Hydrocarbons																
Naphthalene	mg/L	6.4	<-0.000050	<-0.000050	<-0.000050	0.000136	<-0.000050	0.000083	<-0.000050	<-0.000050	<-0.000050	<-0.000050	<-0.000050	<-0.000050	<-0.000050	<-0.000050
Benzo(a)pyrene	mg/L	0.00081	<-0.000010	<-0.000010	<-0.000010	<-0.000010	<-0.000010	<-0.000010	<-0.000010	<-0.000010	<-0.000050	<-0.000050	<-0.000050	<-0.000050	<-0.000050	<-0.000050
Anthracene	mg/L	0.0024	<-0.000050	<-0.000050	<-0.000050	<-0.000050	<-0.000050	<-0.000050	<-0.000050	<-0.000050	<-0.000050	<-0.000050	<-0.000050	<-0.000010	<-0.000010	<-0.000010
Petroleum Hydrocarbons																
F1 (C6-C10 Hydrocarbons)	mg/L	0.75	<-0.025	<-0.025	<-0.025	0.217	<-0.025	0.107	<-0.025	<-0.025	<-0.10	<-0.10	<-0.10	<-0.10	<-0.10	<-0.10
F2 (C10-C16 Hydrocarbons)	mg/L	0.15	<-0.10	<-0.10	<-0.10	<-0.10	<-0.10	<-0.10	<-0.10	<-0.10	<-0.10	<-0.10	<-0.10	<-0.10	<-0.10	<-0.10
F3 (C16-C24 Hydrocarbons)	mg/L	0.50	<-0.20	<-0.20	<-0.20	<-0.20	<-0.20	<-0.20	<-0.20	<-0.20	<-0.25	<-0.25	<-0.25	<-0.25	<-0.25	<-0.25
F4 (C34-C50 Hydrocarbons)	mg/L	0.50	<-0.20	<-0.20	<-0.20	<-0.20	<-0.20	<-0.20	<-0.20	<-0.20	<-0.25	<-0.25	<-0.25	<-0.25	0.27	<-0.25
Benzene	mg/L	0.43	<-0.00010	<-0.00010	<-0.00010	<-0.00250	<-0.00010	<-0.0050	<-0.00010	<-0.00010	<-0.00050	<-0.00050	<-0.00050	<-0.00050	<-0.00050	<-0.00050
Ethylbenzene	mg/L	2.3	<-0.00010	<-0.00010	<-0.00250	<-0.00010	<-0.0050	<-0.00010	<-0.00010	<-0.00050	<-0.00050	<-0.00050	<-0.00050	<-0.00050	<-0.00050	<-0.00050
Toluene	mg/L	18	<-0.00020	0.00027	<-0.00020	0.00065	<-0.00020	0.00046	<-0.00020	0.00048	<-0.00050	<-0.00050	<-0.00050	<-0.00050	<-0.00050	<-0.00050
Xylene (Total)	mg/L	4.2*	<-0.00010	<-0.00010	<-0.00010	0.00075	<-0.00010	0.00029	<-0.00010	0.00095	<-0.00050	<-0.00050	<-0.00050	<-0.00050	<-0.00064	<-0.00064
Volatile Organic Carbons																
Vinyl chloride	mg/L	1.7	<-0.00020	<-0.00020	<-0.00020	<-0.0020	<-0.00020	<-0.0020	<-0.00020	<-0.00020	<-0.00050	<-0.00050	<-0.00050	<-0.00050	<-0.0005	<-0.0005
Pesticides																
Diazinon	µg/L		<2.0	<2.0	<2.0	<2.0	<2.0	<2.0	<2.0	<2.0	<1.0	<1.0	<1.0	<1.0	<1.0	<1.0
Herbicides																
2,4-D	mg/L		<-0.0020	<-0.0020	<-0.0010	<-0.0010	<-0.0010	<-0.0010	<-0.0010	<-0.0010	<-0.00010	<-0.00010	<-0.00010	<-0.00010	<-0.0001	<-0.0001

Note: Criteria from Ontario Ministry of the Environment. (2011, July 1). Soil, Ground Water and Sediment Standards for Use Under Part XV.1 of the Environmental Protection Act Table 3: Full Depth Generic Site Condition Standards in a Non-Potable Ground Water Condition

BRADY ROAD RESOURCE MANAGEMENT FACILITY ANNUAL REPORT – 2020**5.2 SURFACE WATER**

Surface water flows at the BRRMF are managed by perimeter ditching and the central access road, which creates a barrier between the impacted water ditches on the North and the clean water ditches on the South; there are also 8 surface water retention ponds. The system is designed to run dry for most of the year, as such, grab sampling is performed three times per year: spring run-off, summer run-off, and fall run-off. The surface water sampling points are shown in Figure 3.

As per the BRRMF Operating Plan, surface water is managed in accordance with the Surface Water Sampling and Analysis Plan (SAP), as specified under Clause 115. Compliance parameters are applied to the upstream and downstream sampling points, with modifications at other locations interior to the site. Sampling for the clean water ponds (SWQ-25-9a and b) is similar to sampling for perimeter ditching. Sampling for impacted water ponds: Active Area Collection Pond (SWQ-25-6), Biosolids Storm Water Pond (SWQ-25-7), Leaf and Yard Waste Storm Water Pond (SWQ-25-8) and dry ponds (SWQ-25-11 a, b, and c) is performed only prior to discharge events. The Canadian Council of Ministers of the Environment (CCME) Water Quality Guidelines for the Protection of Freshwater Aquatic Life are used as the regulatory guideline (CCME, 2019). Weekly field monitoring is performed at the weir from spring thaw to freeze-up.

In 2020, a total of 27 surface water samples were analyzed – one upstream sample, two downstream samples, eight interior samples, and 16 pond samples. There were no deviations from the Surface Water SAP or from normal sample collection and preservation practices, although we were unable to obtain any fall samples from the ditches as the site was completely dry. Weekly weir data is provided in Table 4 and the 2020 surface water results are provided in Tables 5.1 and 5.2.

The analytical results for some of the pond samples exceeded the guidelines for pH, chloride, cyanide, copper, iron, nickel, and selenium; the water was retained in the ponds or hauled for treatment as required. Many of the analytical results for perimeter ditching were highly variable between sample points. The iron concentration exceeded the guideline at the one interior and one downstream location, and the cadmium concentration exceeded the limit at one downstream location. Samples collected from the ponds and the perimeter ditching frequently contain elevated levels of arsenic, which is due to its natural occurrence in Manitoba soils.

BRADY ROAD RESOURCE MANAGEMENT FACILITY ANNUAL REPORT – 2020

The 2014-2020 averages for upstream and downstream locations are provided in Table 6 and time versus concentration graphs showing the historical relationship of the analytical parameters at each monitoring location are provided in Appendix C. In general, the analytical results for surface water obtained in 2020 were found to be similar to those obtained in 2014-2019, with similar results for upstream and downstream locations. The year 2020 was one of the driest on record and as such there was no surface water to sample in the fall.

The Contingency Action Plan identified under Clause 125 was not implemented in 2020.

At this time, we have no recommendations for changes to the surface water monitoring program.



Water and Waste
Eaux et déchets

Table 4. 2020 Weekly Weir Data

Date	Flow (m/s)	pH (units)	Conductivity (m/s)	DO (mg/L)	Temp (°C)
9-Apr-20	0.0	8.81	4.34	*na	0.4
17-Apr-20	0.0	7.95	5.93	3.9	1.9
24-Apr-20	0.1	9.47	6.52	7.0	14.6
1-May-20	0.0	8.74	8.35	8.2	11.5
8-May-20	0.0	9.55	8.09	13.5	11.9
15-May-20	0.0	9.23	1.09	11.9	15.6
22-May-20	0.1	8.82	1.28	6.7	20.2
29-May-20	0.0	8.84	1.53	10.0	16.6
5-Jun-20	0.0	9.00	1.79	10.8	16.8
12-Jun-20	0.0	8.86	1.68	18.9	25.5
19-Jun-20	0.0	9.33	1.83	18.4	24.9
3-Jul-20	0.0	9.63	1.86	17.9	28.8
10-Jul-20	0.0	9.64	2.11	17.0	28.1
17-Jul-20	0.0	8.92	2.45	8.2	26.2
24-Jul-20	0.0	8.48	2.62	13.1	29.2
31-Jul-20	0.0	8.79	2.43	1.0	23.9
7-Aug-20	0.0	8.54	3.50	6.2	24.2
14-Aug-20	**ns	**ns	**ns	**ns	**ns
21-Aug-20	0.0	8.58	3.45	16.4	31.1
28-Aug-20	**ns	**ns	**ns	**ns	**ns
4-Sep-20	0.0	9.04	3.14	8.7	21.5
11-Sep-20	0.0	8.66	2.75	15.4	16.2
18-Sep-20	**ns	**ns	**ns	**ns	**ns
25-Sep-20	**ns	**ns	**ns	**ns	**ns

*na - not analysed due to equipment malfunction

**ns - no sample because weir was completely dry and/or frozen

Brady Road Resource Management Facility Annual Report – 2020



**Water and Waste
Eaux et déchets**

Table 5.1 2020 Surface Water Monitoring - Ponds

			Ponds																
			SW25-6		SW25-7		SW25-8		SW25-9A		SW25-9B		SW25-11A		SW25-11B		SW25-11C		
Sampling date	Units	Criteria*	28-Apr-20	18-Aug-20	28-Apr-20	18-Aug-20	28-Apr-20	18-Aug-20	28-Apr-20	18-Aug-20	28-Apr-20	18-Aug-20	28-Apr-20	18-Aug-20	28-Apr-20	18-Aug-20	28-Apr-20	18-Aug-20	
Inorganic Parameters																			
Alkalinity - Bicarbonate	mg/L		2,180	2,290	214	130	418	613	221	150	193	207	627	1,150	571	1,160	641	950	
Alkalinity - Carbonate	mg/L		<3.0	215	48.0	106	<3.0	97.8	<3.0	108	<3.0	41.4	21.9	242	27.5	268	44.2	258	
Alkalinity - Hydroxide	mg/L		<3.0	<3.0	<3.0	<3.0	<3.0	<3.0	<3.0	<3.0	<3.0	<3.0	<3.0	<3.0	<3.0	<3.0	<3.0	<3.0	
Alkalinity - Total	mg/L		2,180	2,510	262	236	418	711	221	258	193	248	649	1,400	598	1,430	685	1,210	
Dissolved Hardness (CaCO3)	mg/L		347	194	169	97	96	237	93	109	86	97	177	140	226	192	192	196	
pH	units	6.5-9.0	8.12	8.28	8.94	9.48	7.99	8.54	7.61	9.68	7.59	8.93	8.30	8.60	8.37	8.65	8.51	8.79	
Specific Conductivity	(µS/cm)		6,610	7,760	1,360	1,870	1,670	2,540	584	674	498	591	2,100	6,200	2,060	5,710	2,280	4,980	
Turbidity	(ntu)		149.0	113.0	11.4	32.9	63.4	10.9	16.9	167.0	14.0	54.9	47.2	218.0	30.6	89.2	89.7	95.6	
Total Dissolved Solids	mg/L		3,680	5,590	856	1,480	1,110	1,950	315	511	265	396	1,260	4,470	1,220	3,990	1,530	3,440	
Total Suspended Solids	mg/L		396	359	154	73	270	202	87	213	85	118	376	1,710	209	417	3,892	436	
Total Solids	mg/L		4,070	5,950	1,010	1,560	1,380	2,160	402	724	350	514	1,640	6,180	1,430	4,410	5,420	3,880	
Dissolved Chloride (Cl)	mg/L	640	747	1,480	148	284	184	336	38.2	65.2	27.4	41.0	243	1,610	222	1,160	277	930	
Dissolved Sulphate (SO4)	mg/L		501	298	244	362	158	258	30.9	419	23.7	26.4	124	488	137	426	57.0	372	
Nutrients																			
Ammonia - Dissolved	mg/L N		147	>2.00	0.108	0.024	6.25	0.913	1.85	0.024	2.22	1.38	15.6	>2.00	11.9	>2.00	2.33	1.210	
Nitrate - Dissolved	mg/L N	13	<-0.003	<-0.003	<-0.003	<-0.003	0.027	1.090	0.015	<-0.003	0.029	<-0.003	0.071	<-0.003	0.041	0.109	<-0.003	0.029	
Total Kjeldahl Nitrogen	mg/L N		0.614	0.808	0.286	<-0.013	2.170	3.560	0.325	0.292	0.357	0.581	0.249	0.392	0.639	1.060	1.430	0.900	
Phosphorus - Dissolved	mg/L P		301	157	2.5	6.4	15.2	8.8	2.5	10.7	3.0	4.3	24.9	20.2	20.5	15.7	14.2	13.7	
Other																			
Cyanide - Total (CN)	mg/L	0.0050	0.0105	<-0.0100	0.0018	<-0.0010	0.0038	0.0018	<-0.0010	0.0010	<-0.0010	0.0011	0.0026	0.0018	0.0028	0.0024	0.0043	0.0026	
Organic Indicators																			
Carbonaceous Oxygen Demand	mg/L		1070	1450	109	184	265	359	59	291	58	116	300	633	265	537	820	494	
Biochemical Oxygen Demand	mg/L		83	83	13	18	11	<-4	5	29	6	7	42	17	17	5	98	8	
Metals																			
Arsenic (As)- Dissolved	mg/L	0.0050	0.0310	0.0573	0.0066	0.0199	0.0085	0.0229	0.0033	0.0131	0.0033	0.0170	0.0133	0.0616	0.0120	0.0592	0.0132	0.0395	
Barium (Ba)- Dissolved	mg/L		0.2940	0.1960	0.0462	0.0570	0.0577	0.0769	0.0476	0.0531	0.0405	0.0677	0.0811	0.3340	0.0640	0.2460	0.0579	0.1450	
Beryllium (Be)- Dissolved	mg/L		<-0.00010	0.00018	<-0.00010	<-0.00010	<-0.00010	<-0.00010	<-0.00010	<-0.00010	<-0.00010	<-0.00010	<-0.00010	<-0.00010	<-0.00010	<-0.00010	<-0.00010	<-0.00010	
Cadmium (Cd)- Dissolved	mg/L	0.00009	0.000033	0.000021	<-0.000005	0.000005	0.000014	0.000020	0.000010	0.000006	0.000006	0.000015	0.000027	0.000020	0.000017	0.000005	0.000027	0.000011	
Calcium (Ca)- Dissolved	mg/L		43.8	31.7	72.2	45.3	69.9	129	45.4	50.3	37.3	48.2	55.2	59.1	60.3	86.0	58.4	74.7	
Chromium (Cr)- Dissolved	mg/L		0.06150	0.08820	0.00024	<-0.00010	0.00125	0.00101	0.00027	<-0.00010	0.00020	0.00022	0.00302	0.00191	0.00262	0.00187	0.00229	0.00144	
Copper (Cu)- Dissolved	mg/L	0.0040	0.00392	0.00147	0.00175	0.00067	0.00420	0.00594	0.00108	0.00138	0.00077	0.00144	0.00335	0.00102	0.00241	0.00241	0.00278	0.00419	
Iron (Fe)- Dissolved	mg/L	0.30	1.16	0.686	0.033	<-0.010	0.427	0.124	0.117	0.016	0.154	0.099	0.076	0.044	0.069	0.046	0.068	0.031	
Lead (Pb)- Dissolved	mg/L	0.0070	0.000417	0.000347	<-0.000050	<-0.000050	0.000435	0.000283	0.000101	0.000050	0.000073	0.000118	0.000259	0.000148	0.000127	0.000163	0.000157	0.000236	
Magnesium (Mg)- Dissolved	mg/L		251	352	86.3	136	81.0	138	35.0	45.2	27.5	37.4	130	435	127	395	121	326	
Manganese (Mn)- Dissolved	mg/L		0.3380	0.0713	0.1740	0.0064	0.4570	0.4120	0.1780	0.0121	0.2290	0.1030	0.1200	0.0793	0.0901	0.0731	0.1560	0.0436	
Mercury (Hg)- Dissolved	mg/L	0.000026	<-0.000010	<-0.000050	<-0.000010	<-0.000005	0.000010	0.000006	<-0.000010	<-0.000005	0.000010	<-0.000005	0.000010	<-0.000005	0.000010	<-0.000005	0.000010	<-0.000005	
Nickel (Ni)- Dissolved	mg/L	0.150	0.1350	0.1850	0.0089	0.0075	0.0220	0.0300	0.0039	0.0044	0.0034	0.0046	0.0422	0.1070	0.0360	0.0914	0.0326	0.0779	
Potassium (K)- Dissolved	mg/L		181	254	44.8	68.0	211	366	14.2	17.4	14.3	17.5	71.3	262	73.3	226	70.8	200	
Selenium (Se)- Dissolved	mg/L	0.0010	0.002160	0.001290	0.000389	0.000398	0.000659	0.000983	0.000232	0.000229	0.000259	0.000207	0.000611	0.001130	0.000491	0.001030	0.000529	0.001150	
Sodium (Na)- Dissolved	mg/L		772	1,130	91.5	165	60.7	98.9	20.5	30.3	15.3	23.7	191	777	184	678	170	588	
Zinc (Zn)- Dissolved	mg/L	0.030	0.0158	0.0081	0.0018	<-0.0010	0.0061	0.0056	0.0048	<-0.0010	0.0033	0.0025	0.0070	0.0011	0.0047	0.0019	0.0043	0.0018	
Bacteria																			
Total Coliforms (MTF)	MPN/100mL		24,200	15500	118	>2,420	370	5,250	>2,420	>24,200	272	>2,420	>2,420	>2,420	961	>2,420	>24,200	>2,420	
Fecal Coliforms (MTF)	MPN/100mL		2,610	4,880	19	105	140	360	>2,420	>24,200	21	138	>2,420	>2,420	118	387	50	2,420	
E. coli (MTF)	MPN/100mL		2,380	6,130	10	116	20	340	1,550	24,200	8	248	>2,420	>2,420	75	276	10	1,990	
Field Parameters																			
pH	units	6.5-9.0	8.50	8.86	9.19	9.99	8.46	9.01	8.08	10.10	8.22	9.41	8.68	9.03	8.64	9.14	8.76	9.73	
Specific Conductivity	(µS/cm)		5,150	6,670	12,580	1,770	15,560	2,400	5,760	640	4,940	577	19,280	5,330	18,410	4,740	17,390	280	
Temperature			10.8	19.7	11.0	20.2	10.9	23.0	9.3	21.6	8.9	21.8	10.9	25.0	10.9	22.0	11.5	23.0	

Note: Criteria from Canadian Council of Ministers of the Environment. Canadian Environmental Quality Guidelines Summary Table. Water Quality Guidelines for the Protection of Freshwater Aquatic Life. (CCME, 2019)

* Criteria for total chloride and total metals
** NA - Not analysed

Brady Road Resource Management Facility Annual Report – 2020



Water and Waste
Eaux et déchets

Table 5.2 2020 Surface Water Monitoring - Perimeter Ditch

Sampling date	Units	Criteria*	Upstream		Downstream			Interior											
			SW25-1		SW25-2		SW25-12		SW25-13A		SW25-14A		SW25-14B		SW25-15A		SW25-15B		
			28-Apr-20	**	28-Apr-20	**	28-Apr-20	28-Apr-20	18-Aug-20	**	28-Apr-20	**	28-Apr-20	**	28-Apr-20	**	28-Apr-20	**	28-Apr-20
Inorganic Parameters																			
Alkalinity - Bicarbonate	mg/L		149		252		242	152	235		148		157		216		193	175	298
Alkalinity - Carbonate	mg/L	<3.0			<3.0		<3.0	<3.0	<3.0		<3.0		<3.0		<3.0		<3.0	<3.0	<3.0
Alkalinity - Hydroxide	mg/L	<3.0			<3.0		<3.0	<3.0	<3.0		<3.0		<3.0		<3.0		<3.0	<3.0	<3.0
Alkalinity - Total	mg/L		149		252		242	152	235		148		157		216		193	175	298
Dissolved Hardness (CaCO3)	mg/L		70.9		76.8		124	76.8	450		74.6		109		72.7		72.7	58.8	96.5
pH	units	6.5-9.0	7.35		7.76		7.52	7.30	7.57		7.31		7.41		7.78		7.66	7.71	7.71
Specific Conductivity	(µS/cm)		344		741		821	372	2,410		364		480		658		490	540	831
Turbidity	(ntu)		7.01		12.6		41.7	2.47	9.11		2.78		3.74		6.73		26.7	19.4	119
Total Dissolved Solids	mg/L		208		424		457	206	2,120		199		263		355		261	291	4,200
Total Suspended Solids	mg/L		54		252		173	40	281		41		49		25		163	567	1,570
Total Solids	mg/L		262		676		630	246	2,400		240		312		380		424	858	5,770
Dissolved Chloride (Cl)	mg/L	640	12.9		51.0		90.0	17.1	155		18.3		32.4		45.0		19.0	22.0	54.0
Dissolved Sulphate (SO4)	mg/L		<0.4		54.7		21.0	<0.4	890		2.6		39.5		46.7		13.9	23.7	45.6
Nutrients																			
Ammonia - Dissolved	mg/L N		0.062		0.026		0.049	0.221	0.072		0.018		0.039		0.333		1.860	0.505	1.630
Nitrate - Dissolved	mg/L N	13	0.006		0.863		0.123	0.003	0.030		0.003		0.006		0.018		0.030	0.176	0.244
Total Kjeldahl Nitrogen	mg/L N		0.3		2.1		3.0	<0.2	1.8		<0.2		<0.2		0.8		4.3	7.2	10.6
Phosphorus - Dissolved	mg/L P		0.140		0.283		<0.013	0.182	<0.013		0.175		0.163		0.105		0.289	0.206	0.340
Other																			
Cyanide - Total (CN)	mg/L	0.0050	<0.0010		0.0010		0.0015	<0.0010	0.0011		<0.0010		<0.0010		<0.0010		<0.0010	<0.0010	0.0013
Organic Indicators																			
Carbonaceous Oxygen Demand	mg/L		49		154		126	38	188		39		43		49		120	320	1,760
Biochemical Oxygen Demand	mg/L		4		13		24	<4	9		4		<4		5		18	56	252
Metals																			
Arsenic (As)- Dissolved	mg/L	0.0050	0.00295		0.00540		0.00293	0.00337	0.00172		0.00280		0.00274		0.00311		0.00325	0.00398	0.00521
Barium (Ba)- Dissolved	mg/L		0.0276		0.0482		0.0997	0.0291	0.0631		0.0277		0.0315		0.0530		0.0392	0.0438	0.0487
Beryllium (Be)- Dissolved	mg/L		<0.00010		<0.00010		<0.00010	<0.00010	<0.00010		<0.00010		<0.00010		<0.00010		<0.00010	<0.00010	<0.00010
Cadmium (Cd)- Dissolved	mg/L	0.00009	0.000013		0.000400		0.000005	<0.000005	0.000009		<0.000005		0.000008		0.000006		0.000007	0.000012	0.000012
Calcium (Ca)- Dissolved	mg/L		30.7		45.1		98.7	32.1	203		31.5		37.1		51.8		37.7	43.0	46.6
Chromium (Cr)- Dissolved	mg/L		0.00014		0.00042		0.00035	0.00016	<0.00010		0.00014		0.00018		0.00016		0.00016	0.00017	0.00041
Copper (Cu)- Dissolved	mg/L	0.0040	0.00191		0.00117		0.00174	0.00096	0.00186		0.00107		0.00169		0.00157		0.00121	0.00094	0.00112
Iron (Fe)- Dissolved	mg/L	0.30	0.095		0.082		0.644	0.187	0.474		0.150		0.177		0.071		0.132	0.080	0.083
Lead (Pb)- Dissolved	mg/L	0.0070	0.000096		0.000102		0.000051	0.000055	<0.000050		<0.000050		0.000167		0.000064		0.000069	0.000055	<0.000050
Magnesium (Mg)- Dissolved	mg/L		20.1		44.8		86.2	20.6	208		20.0		28.0		41.2		26.5	31.4	45.3
Manganese (Mn)- Dissolved	mg/L		0.0616		0.0611		0.690	0.0652	0.733		0.0246		0.0296		0.0598		0.235	0.104	0.132
Mercury (Hg)- Dissolved	mg/L	0.000026	<0.00001		<0.00001		0.00001	<0.00001	<0.000005		<0.00001		<0.00001		<0.00001		<0.00001	<0.00001	<0.00001
Nickel (Ni)- Dissolved	mg/L	0.150	0.00214		0.00781		0.00460	0.00233	0.00379		0.00229		0.00434		0.00329		0.00329	0.00363	0.00742
Potassium (K)- Dissolved	mg/L		9.19		22.9		16.3	9.21	18.1		8.97		9.03		11.8		14.3	14.5	21.7
Selenium (Se)- Dissolved	mg/L	0.0010	0.000188		0.000370		0.000449	0.000147	0.000312		0.000129		0.000125		0.000371		0.000301	0.000355	0.000389
Sodium (Na)- Dissolved	mg/L		8.94		39.4		73.0	11.8	136		11.4		26.6		14.4		14.4	16.8	36.9
Zinc (Zn)- Dissolved	mg/L	0.030	0.0037		0.0057		0.0047	0.0039	0.0162		0.0024		0.0142		0.0075		0.0026	0.0033	0.0026
Bacteria																			
Total Coliforms (MTF)	MPN/100mL		365		461		>2,420	770	>2,420		308		461		980		291	435	>2,420
Fecal Coliforms (MTF)	MPN/100mL		3		17		25	411	166		47		66		613		17	1	>2,420
E. coli (MTF)	MPN/100mL		1		3		19	308	157		59		50		365		14	5	47
Field Parameters																			
pH	units	6.5-9.0	8.19		8.02		8.01	7.92	8.51		7.62		7.86		8.22		8.28	8.41	8.32
Specific Conductivity	(µS/cm)		3,780		7,060		7,720	3,550	2,460		3,970		4,630		6,460		4,630	5,160	6,410
Temperature			9.3		10.4		8.1	8.6	15.2		9.5		9.4		9.0		9.3	8.8	9.1

Note: Criteria from Canadian Council of Ministers of the Environment. Canadian Environmental Quality Guidelines Summary Table. Water Quality Guidelines for the Protection of Freshwater Aquatic Life. (CCME, 2019)
 * Criteria for total chloride and total metals
 ** No fall samples taken due to no flow

Brady Road Resource Management Facility Annual Report – 2020



Water and Waste
Eaux et déchets

Table 6. 2020 Surface Water Monitoring - Perimeter Ditch Comparison

	Units	Criteria	2014		2015		2016		2017		2018		2019		2020	
			Average		Average		Average		Average		Average		Average		Average	
			Upstream	Downstream	Upstream	Downstream	Upstream	Downstream	Upstream	Downstream	Upstream	Downstream	Upstream	Downstream	Upstream	Downstream
Inorganic Parameters																
Alkalinity - Bicarbonate	mg/L		258	322	222	207	254	349	359	433	174	300	243	447	149	252
Alkalinity - Carbonate	mg/L		<0.50	28.4	<0.50	15.5	<0.50	<0.50	<0.50	<0.50	<3.0	18	<3.0	16	<3.0	<3.0
Alkalinity - Hydroxide	mg/L		<0.50	<0.50	<0.50	<0.50	<0.50	<0.50	<0.50	<0.50	<3.0	<3.0	<3.0	<3.0	<3.0	<3.0
Alkalinity - Total	mg/L		212	311	271	221	208	287	294	355	174	243	243	462	149	252
Dissolved Hardness (CaCO3)	mg/L		220	473	286	383	515	523	316	448	248	499	175	188	71	77
pH	units	6.5-9.0	7.41	8.63	7.55	9.11	7.40	8.15	7.68	8.80	7.56	8.84	7.51	8.35	7.35	7.76
Specific Conductivity	(µS/cm)		428	1,266	689	1,056	1,029	1,588	774	1,154	615	1,590	573	4,637	344	741
Turbidity	(ntu)		610	533	636	72.3	151	135	118	87.2	37.2	32.8	279.7	22.1	7.0	12.6
Total Dissolved Solids	mg/L		421	963	516	795	721	1,025	496	810	370	996	373	1,345	208	424
Total Suspended Solids	mg/L		1,265	1,982	693	112	483	531	379	169	116	167	499	149	54	252
Total Solids	mg/L		1,686	2,945	1,209	907	1,204	1,557	875	978	486	1,164	871	1,495	262	676
Dissolved Chloride (Cl)	mg/L	640 *	20.0	154	54.0	116	61.3	209	62.0	151	60.0	220	30	376	13	51
Dissolved Sulphate (SO4)	mg/L		7.3	135	35.7	138	205	227	32.5	33.2	57.6	170	16	129	<0.4	55
Nutrients																
Ammonia - Dissolved	mg/L N		0.063	0.877	<0.003	0.009	0.295	0.730	0.009	0.560	0.041	0.426	0.043	0.688	0.062	0.026
Nitrate - Dissolved	mg/L N	13	0.327	0.243	0.005	<0.003	3.96	2.98	<0.003	0.184	0.234	0.500	0.008	0.282	0.006	0.863
Total Kjeldahl Nitrogen	mg/L N		5.30	5.70	4.32	2.30	5.40	13.1	1.95	3.35	2.55	6.85	1.63	5.80	0.30	2.10
Phosphorus - Dissolved	mg/L P		0.253	0.214	0.135	0.036	0.060	0.060	0.382	0.195	0.085	0.252	0.127	0.567	0.140	0.283
Other																
Cyanide - Total (CN)	mg/L	0.0050	0.0012	0.0025	0.0014	0.0021	0.0016	0.0027	0.0020	0.0023	0.0007	0.0025	<0.0010	0.0019	<0.0010	0.0010
Organic Indicators																
Chemical Oxygen Demand	mg/L		282	188	154	78	131	249	255	135	50	530	143	169	49	154
Biochemical Oxygen Demand	mg/L		17	23	10	10	12	51	<3	23	7	13	6	8	4	13
Metals																
Arsenic (As)- Dissolved	mg/L	0.0050*	0.0044	0.0063	0.0030	0.0063	0.0029	0.0059	0.0053	0.0086	0.0028	0.0089	0.0040	0.0134	0.0030	0.0054
Barium (Ba)- Dissolved	mg/L		0.0443	0.1148	0.0575	0.0500	0.0479	0.0872	0.0540	0.0689	0.0537	0.0702	0.0501	0.0946	0.0276	0.0482
Beryllium (Be)- Dissolved	mg/L		<0.000010	<0.000050	0.000021	<0.000010	<0.000010	<0.000010	<0.000010	<0.000010	<0.00010	<0.00010	<0.00010	<0.00010	<0.00010	<0.00010
Cadmium (Cd)- Dissolved	mg/L	0.000090 *	0.000008	0.000015	0.000027	0.000018	0.000062	0.000009	<0.0000050	0.000007	0.000036	0.000057	0.000012	0.000013	0.000013	0.000400
Calcium (Ca)- Dissolved	mg/L		57.5	70.7	54.9	46.0	126.2	60.4	55.0	42.9	47.7	50.0	50.4	64.1	30.7	45.1
Chromium (Cr)- Dissolved	mg/L		0.00015	0.00150	0.00013	0.00029	0.00020	0.00049	0.00023	0.00026	0.00018	0.00042	0.00018	0.00093	0.00014	0.00042
Copper (Cu)- Dissolved	mg/L	0.0040 *	0.00041	0.00211	0.00164	0.00257	0.00348	0.00502	0.00220	0.00267	0.00229	0.00527	0.00134	0.00210	0.00191	0.00117
Iron (Fe)- Dissolved	mg/L	0.30 *	0.301	0.031	0.100	0.030	0.172	0.032	0.156	0.034	0.059	0.020	0.163	0.062	0.095	0.082
Lead (Pb)- Dissolved	mg/L	0.0070 *	0.000041	0.000059	0.000058	0.000070	0.000041	0.000105	0.000157	0.000150	0.000285	0.000060	0.000077	<0.000050	0.000096	0.000102
Magnesium (Mg)- Dissolved	mg/L		40.9	98.2	36.2	64.9	48.7	90.7	43.5	55.4	31.3	91.0	32.4	120.9	20.1	44.8
Manganese (Mn)- Dissolved	mg/L		0.5400	0.0735	0.0519	0.0317	0.1614	0.1725	0.3010	0.0378	0.0101	0.0322	0.0892	0.0660	0.0616	0.0611
Mercury (Hg)- Dissolved	mg/L	0.000026 *	0.000004	0.000002	<0.000010	<0.000010	0.000003	0.000003	0.000002	<0.000002	<0.000005	<0.000005	<0.000005	<0.000005	<0.000010	<0.000010
Nickel (Ni)- Dissolved	mg/L	0.150 *	0.00195	0.02070	0.00269	0.01113	0.00277	0.01890	0.00245	0.01090	0.00262	0.02010	0.00340	0.02620	0.00214	0.00781
Potassium (K)- Dissolved	mg/L		7.1	34.6	11.4	20.6	12.3	37.9	9.0	27.0	10.2	68.4	12.0	73.0	9.2	22.9
Selenium (Se)- Dissolved	mg/L	0.0010 *	0.000156	0.000350	0.000118	0.000308	0.000233	0.000475	0.000166	0.000258	0.000155	0.000429	0.000229	0.000403	0.000188	0.000370
Sodium (Na)- Dissolved	mg/L		26.5	107	26.7	74.7	31.3	100	36.4	89.2	29.4	124	20	171	8.9	39
Zinc (Zn)- Dissolved	mg/L	0.030 *	0.0021	0.0086	0.0052	0.0051	0.0043	0.0053	0.0029	0.0033	0.0026	0.0047	0.0014	0.0026	0.0037	0.0057
Bacteria																
Total Coliforms (MTF)	MPN/100mL		1,415	4,777	6,000	5,267	11,000	>11,000	5,965	5,715	6,710	3,510	2,253	1,950	365	461
Fecal Coliforms (MTF)	MPN/100mL		195	887	225	93	336	4,008	2,301	33	23	530	118	1,076	3	17
E. coli (MTF)	MPN/100mL		195	887	235	76	336	3,979	2,301	19	6	765	86	972	1	3
Field Parameters																
pH	units	6.5-9.0	NA	NA	7.36	8.88	7.40	8.15	7.68	8.80	7.56	8.84	8.18	8.65	8.19	8.02
Specific Conductivity	(µS/cm)		NA	NA	702	1,000	947	1,380	720	450	660	1,619	2,029	1,850	3,780	7,060
Temperature	°C		NA	NA	NA	NA	NA	NA	NA	NA	19.7	7.2	11.3	12.1	9.3	10.4

Note: Criteria from Canadian Council of Ministers of the Environment, Canadian Environmental Quality Guidelines Summary Table, Water Quality Guidelines for the Protection of Freshwater Aquatic Life, (CCME, 2019)
 * Criteria for total chloride and total metals
 ** SW16 is not used in the calculation for the downstream average because it is not affected by Brady runoff
 NA - not analyzed

Client File No. 5556.00

Manitoba Environment Act Licence No. 3081 R

BRADY ROAD RESOURCE MANAGEMENT FACILITY ANNUAL REPORT – 2020**5.3 LEACHATE**

The leachate management system is a network of manholes/risers, drains, and sumps around the perimeter of the landfill cells, which feed into a header pipe. The leachate flows via gravity and lift stations into a 300,000L storage tank located at the intersection of Charette Road and the access road, which acts as a truck fill station for hauling to the North End Sewage Treatment Plant for treatment. Leachate can also be pumped from eleven collection manholes and one riser if needed; these sites also serve as sampling points. The locations of the manholes and riser are shown on Figure 3.

As per the BRRMF Operating Plan, leachate is managed in accordance with the Leachate Sampling and Analysis Plan (SAP), as specified under Clause 100. The MOE guidelines for non-potable groundwater quality are used as the regulatory guideline (MOE, 2011).

The total volume of leachate removed from the BRRMF in 2020 was 46,374 kL. There were no occurrences of leachate breakout from the development in 2020. The Contingency Action Plan identified under Clause 125 was not implemented in 2020.

In 2020, twelve leachate samples were analyzed; there were no deviations from the Leachate SAP or from normal sample collection and preservation practices. Monthly leachate elevations are provided in Table 7, and the 2020 leachate results are provided in Table 8. The majority of parameters were found to be highly variable between manholes; some of the samples exceeded the guidelines for chloride, nickel, extractables, hydrocarbons and vinyl chloride. Leachate is highly variable due to waste composition, amount of precipitation, site hydrology, waste compaction, cover, and interaction of leachate with the environment.

The 2014-2020 average results are provided in Table 9, and Piper diagrams showing the historical relationship of cations and anions at each monitoring location are provided in Appendix B. Many of the other parameters measured vary significantly from year to year. The average alkalinity, hardness, and conductivity have been increasing yearly since 2015 because improved landfill cover allows less water infiltration, which aids the biological breakdown of inorganic compounds – this was especially true for 2020, which was one of the driest years on record.

We have no recommendations for changes to the leachate monitoring program at this time.

Brady Road Resource Management Facility Annual Report – 2020



**Water and Waste
Eaux et déchets**

Table 7. 2020 Leachate Levels

	Date	7-Jan-20	10-Feb-20	5-Mar-20	23-Apr-20	5-May-20	9-Jun-20	6-Jul-20	13-Aug-20	16-Sep-20	22-Oct-20	24-Nov-20	17-Dec-20
Manhole 3	Top of Manhole Elevation (m)	233.66	233.66	233.66	233.66	233.66	233.66	233.66	233.66	233.66	233.66	233.66	233.66
	Depth to Leachate (m)	2.10	2.76	4.44	5.25	7.13	8.28	8.43	8.36	8.48	6.21	8.08	5.88
	Manhole Leachate Elevation (m)	231.56	230.90	229.22	228.41	226.53	225.38	225.23	225.30	225.18	227.45	225.58	227.78
Manhole 8	Top of Manhole Elevation (m)	236.61	236.61	236.61	236.61	236.61	236.61	236.61	236.61	236.61	236.61	236.61	236.61
	Depth to Leachate (m)	8.45	8.03	9.20	6.73	8.91	9.02	9.33	8.95	7.04	9.28	9.17	9.27
	Manhole Leachate Elevation (m)	228.16	228.58	227.41	229.88	227.70	227.59	227.28	227.66	229.57	227.33	227.44	227.34
Manhole 13	Top of Manhole Elevation (m)	234.89	234.89	234.89	234.89	234.89	234.89	234.89	234.89	234.89	234.89	234.89	234.89
	Depth to Leachate (m)	5.20	9.68	9.04	8.11	8.93	9.22	6.00	5.37	8.59	9.36	8.37	8.76
	Manhole Leachate Elevation (m)	229.69	225.21	225.85	226.78	225.96	225.67	228.89	229.52	226.30	225.53	226.52	226.13
Manhole 24	Top of Manhole Elevation (m)	235.00	235.00	235.00	235.00	235.00	235.00	235.00	235.00	235.00	235.00	235.00	235.00
	Depth to Leachate (m)	7.43	9.98	8.29	7.02	7.74	7.42	7.72	9.14	7.53	6.42	8.37	8.27
	Manhole Leachate Elevation (m)	227.57	225.02	226.71	227.98	227.26	227.58	227.28	225.86	227.47	228.58	226.63	226.73
Manhole 27	Top of Manhole Elevation (m)	235.71	235.71	235.71	235.71	235.71	235.71	235.71	235.71	235.71	235.71	235.71	235.71
	Depth to Leachate (m)	1.95	2.00	1.77	2.07	2.68	2.15	2.00	2.03	2.31	2.11	2.22	2.21
	Manhole Leachate Elevation (m)	233.76	233.71	233.94	233.64	233.03	233.56	233.71	233.68	233.40	233.60	233.49	233.50
Manhole 31	Top of Manhole Elevation (m)	234.74	234.74	234.74	234.74	234.74	234.74	234.74	234.74	234.74	234.74	234.74	234.74
	Depth to Leachate (m)	4.44	6.01	0.68	8.32	1.22	2.00	2.58	4.35	4.39	2.02	2.67	1.79
	Manhole Leachate Elevation (m)	230.30	228.73	234.06	226.42	233.52	232.74	232.16	230.39	230.35	232.72	232.07	232.95
Manhole 34	Top of Manhole Elevation (m)	235.42	235.42	235.42	235.42	235.42	235.42	235.42	235.42	235.42	235.42	235.42	235.42
	Depth to Leachate (m)	2.42	2.48	2.57	2.42	2.23	2.44	2.04	2.20	2.32	2.60	2.45	2.27
	Manhole Leachate Elevation (m)	233.00	232.94	232.85	233.00	233.19	232.98	233.38	233.22	233.10	232.82	232.97	233.15
Manhole 46	Top of Manhole Elevation (m)	235.04	235.04	235.04	235.04	235.04	235.04	235.04	235.04	235.04	235.04	235.04	235.04
	Depth to Leachate (m)	5.33	5.47	2.64	5.19	5.11	5.37	3.26	5.05	5.75	5.42	5.88	*na
	Manhole Leachate Elevation (m)	229.71	229.57	232.40	229.85	229.93	229.67	231.78	229.99	229.29	229.62	229.16	-
Riser 1	Top of Riser Elevation (m)	234.97	234.97	234.97	234.97	234.97	234.97	234.97	234.97	234.97	234.97	234.97	234.97
	Depth to Leachate (m)	7.07	7.01	7.05	7.60	7.03	7.11	7.39	7.55	7.34	7.47	7.22	7.40
	Riser Leachate Elevation (m)	227.90	227.96	227.92	227.37	227.94	227.86	227.58	227.42	227.63	227.50	227.75	227.57

*na - unable to measure due to high levels of gas

**Client File No. 5556.00
Manitoba Environment Act Licence No. 3081 R**

Brady Road Resource Management Facility Annual Report – 2020

			Table 8. 2020 Leachate Monitoring												
Sampling Date	Units	Criteria*	LQ25-MH3	LQ25-MH8	LQ25-MH13	LQ25-MH24	LQ25-MH27	LQ25-MH31	LQ25-MH34	LQ25-MH46	LQ25-MH47	Leachate Tank	BIO 1	RISER 1	Composite
			Sep-20	Sep-20	Sep-20	Sep-20	Sep-20	Sep-20	Sep-20	Sep-20	Sep-20	Sep-20	Sep-20	Sep-20	Sep-20
Field Parameters															
pH	units		7.44	7.63	7.36	7.28	7.95	7.25	7.66	6.99	5.79	7.89	7.45	7.96	
Turbidity	ntu		91.0	71.5	36.8	nr	9.12	64.3	2.70	101.0	105.0	176.0	3.78	186.0	
Specific Conductivity	uS/cm		11,140	13,400	8,380	10,300	5,900	11,470	16,420	8,280	6,570	10,900	3,300	15,860	
Temperature	°C		15.0	13.8	10.2	13.5	11.3	11.6	9.9	10.1	3.6	10.3	14.3	14.4	
Inorganic Parameters															
Alkalinity - Bicarbonate	mg/L		6,810	7,920	6,140	6,860	276	6,820	425	7,420	4,630	6,980	74.2	10,900	
Alkalinity - Carbonate	mg/L		<3.0	<3.0	<3.0	<3.0	<3.0	<3.0	<3.0	<3.0	<3.0	<3.0	<3.0	<3.0	
Alkalinity - Hydroxide	mg/L		<3.0	<3.0	<3.0	<3.0	<3.0	<3.0	<3.0	<3.0	<3.0	<3.0	<3.0	<3.0	
Alkalinity - Total	mg/L		6,810	7,920	6,140	6,860	276	6,820	425	7,420	4,630	6,980	74.2	10,900	
Hardness (as CaCO3)	mg/L		2,450	1,720	2,770	2,070	230	2,180	679	3,300	5,010	2,920	91.9	2,550	
pH	units		7.23	7.30	7.30	7.51	7.85	7.59	7.74	7.24	5.83	7.47	7.31	7.60	
Specific Conductivity	uS/cm		15,100	18,100	14,100	14,500	573	15,300	1,720	15,600	10,300	15,600	327	21,500	
Turbidity	ntu		95.7	73.1	31.0	31.6	6.09	47.4	3.65	266	85.1	143	4.62	154	
Total Dissolved Solids	mg/L		7,950	8,490	7,990	6,970	354	7,760	1,260	8,970	17,500	9,430	304	10,800	
Total Suspended Solids	mg/L		432	398	282	220	52	238	18	1,043	590	784	24	402	
Total Solids	mg/L		8,380	8,880	8,270	7,190	406	8,000	1,280	10,000	18,100	10,200	328	11,200	
Chloride (dissolved)	mg/L	2,300	2,860	1,910	1,990	1,690	23.4	1,800	158	1,610	1,050	1,810	14.8	2,560	
Sulphate (dissolved)	mg/L		<0.4	<0.4	<0.4	42	42	2.5	226	<0.4	727	<0.4	29.6	<0.4	
Other															
Cyanide (CN)	mg/L	0.066	0.013	0.014	0.009	0.011	<0.0010	0.016	0.001	0.016	0.006	0.013	0.004	0.023	
Nutrients															
Dissolved Ammonia	mg/L		879	1,160	444	888	6.22	717	3.71	822	336	933	6.73	1,510	
Nitrate Nitrite Nitrogen	mg/L		<0.003	0.032	<0.003	<0.003	0.084	<0.003	8.81	<0.003	<0.003	<0.003	12	0.117	
Total Kjeldahl Nitrogen	mg/L		1,310	2,050	896	1,490	4.85	1,170	0.22	1,120	571	1,190	2.93	1,930	
Phosphorus (Total)	mg/L		2.20	5.80	1.77	4.68	0.562	1.82	0.222	2.80	15.4	3.3	1.3	2.05	
Organic Indicators															
Biological Oxygen Demand	mg/L		299	171	82	83	7	175	<4	874	13,100	746	4	542	
Chemical Oxygen Demand	mg/L		1,960	2,930	1,470	1,430	76	1,930	86	4,870	1,070	5,100	130	3,540	
Metals															
Total Arsenic (As)	mg/L	1.9	0.009881	0.016167	0.009533	0.005288	0.001660	0.005770	0.000841	0.031079	0.017476	0.009027	0.001170	0.010740	
Total Barium (Ba)	mg/L	29	0.61028	0.52730	0.64116	0.32981	0.081326	0.49164	0.12766	0.41014	0.77054	0.51346	0.03898	0.16794	
Total Beryllium (Be)	mg/L	0.067	<0.00003	<0.00003	<0.00003	<0.00003	<0.00003	<0.00003	<0.00003	<0.00003	<0.00003	<0.00003	<0.00003	<0.00003	
Total Cadmium (Cd)	mg/L	0.0027	<0.000007	<0.000007	<0.000007	<0.000007	<0.000007	<0.000007	<0.000007	<0.000007	<0.000007	<0.000007	<0.000007	<0.000007	
Total Calcium (Ca)	mg/L		191.52	131.43	186.93	172.47	50.514	157.41	129.44	509.61	1,527.0	401.99	22.588	88.952	
Total Chromium (Cr)	mg/L	0.81	0.14354	0.18091	0.05401	0.05773	0.00895	0.11666	0.00613	0.14671	0.36128	0.13699	0.00602	0.28413	
Total Chromium (Hexavalent)	mg/L	0.14	0.00089	0.00144	0.00121	0.00072	<0.00050	<0.00050	<0.00050	0.00102	<0.00050	0.00053	<0.00050	0.00111	
Total Copper (Cu)	mg/L	0.087	0.009495	0.049750	0.006533	0.006309	0.008239	0.016036	0.011887	0.012937	0.012023	0.008893	0.016667	0.017963	
Total Iron (Fe)	mg/L		14.234	2.360	2.779	4.459	1.034	7.828	0.131	40.379	196.140	19.695	0.205	2.909	
Total Lead (Pb)	mg/L	0.025	0.006103	0.002864	0.014983	<0.000065	0.000713	<0.000065	<0.000065	0.005033	0.010470	<0.000065	0.000352	0.000733	
Total Magnesium (Mg)	mg/L		479.37	337.31	559.80	399.20	25.175	434.82	86.40	492.24	290.54	465.59	8.624	566.38	
Total Manganese (Mn)	mg/L		0.21663	0.19677	0.21115	0.23590	0.14314	0.19270	0.12682	2.0867	15.364	2.0211	0.03421	0.15899	
Total Mercury (Hg)	mg/L	0.0028	<0.000050	<0.000050	<0.000050	<0.000050	<0.000050	<0.000050	<0.000050	<0.000050	<0.000050	<0.000050	0.000005	0.000080	
Total Nickel (Ni)	mg/L	0.49	0.25357	0.33081	0.24059	0.18874	0.004173	0.28653	0.012837	0.29413	0.45815	0.30524	0.00332	0.59952	
Total Potassium (K)	mg/L		487.81	587.58	470.15	513.86	20.829	528.30	46.686	472.79	371.78	549.02	21.04	637.77	
Dissolved Selenium (Se)	mg/L	0.063	0.00125	0.00174	0.00102	0.00112	0.000425	0.00151	0.00055	0.00168	0.00550	0.00290	0.00039	0.00299	
Total Silver (Ag)	mg/L	0.0015	0.000140	0.000140	<0.000100	<0.000100	<0.000100	0.000140	<0.000100	<0.000100	<0.000100	<0.000100	0.000020	0.000400	
Total Sodium (Na)	mg/L	2,300	1,414.5	1,657.2	1,345.4	1,282.5	14.0	1,542.7	96.4	1,389.6	927.5	1,448.7	5.434	2,108.6	
Total Zinc (Zn)	mg/L	1.1	0.09809	0.33489	0.06653	0.13650	0.02683	0.06589	0.02956	0.74021	1.0926	0.2792	0.0451	0.23634	
Extractables															
Benzo (a) Pyrene (PAH)	mg/L	0.00081	0.000097	0.000340	0.000182	0.0000147	0.0000724	0.000032	0.0000122	<0.0000140	<0.000050	0.0000728	<0.000050	0.000072	
Anthracene	mg/L	0.0024	0.000221	0.008370	0.000824	<0.000210	0.000345	0.000408	0.001380	0.00109	<0.000010	0.000317	<0.000010	0.00021	
4'4' Methylenebis 2 Chloroaniline	ug/L		<1.0	<5.0	<1.0	<1.0	<0.50	<1.0	<0.50	<1.50	<1.50	<0.50	<0.50	<1.50	
Benzo (a) anthracene (PAH)	mg/L	0.0047	0.000039	<0.000120	0.000468	0.000047	0.000152	0.000128	<0.000054	0.000036	<0.000010	0.000175	<0.000010	0.000016	
Benzo (b/j) fluoroanthene (PAH)	mg/L		0.000013	0.009060	0.000164	0.000021	0.000192	0.000055	0.000043	0.000013	<0.000010	0.000083	<0.000010	0.000010	
Benzo (g,h,i) Perylene (PAH)	mg/L	0.0002	<0.000020	0.001840	0.000077	<0.000020	0.000025	<0.000020	<0.000020	<0.000020	<0.000020	0.000028	<0.000020	<0.000020	
Hexachlorobenzene	ug/L	3.1	<0.040	<0.040	<0.040	<0.040	<0.040	<0.040	<0.040	<0.040	<0.040	<0.040	<0.040	<0.040	
Phenanthrene	mg/L	0.58	0.00163	0.02320	0.00464	0.00132	0.00343	0.00246	0.00836	0.000752	<0.000050	0.00209	<0.000050	0.000121	
Phenol	mg/L	12	0.117	0.029	0.003	0.001	<0.001	0.005	0.001	0.169	0.742	0.680	0.001	0.446	

Note: Criteria from Ontario Ministry of the Environment. (2011, July 1). Soil, Ground Water and Sediment Standards for Use Under Part XV.I of the Environmental Protection Act Table 3: Full Depth Generic Site Condition Standards in a Non-Potable Ground Water Condition
*Criteria for total chloride and total selenium.

Brady Road Resource Management Facility Annual Report – 2020



**Water and Waste
Eaux et déchets**

Table 8. 2020 Leachate Monitoring

Sampling Date	Units	Criteria*	LQ25-MH3	LQ25-MH8	LQ25-MH13	LQ25-MH24	LQ25-MH27	LQ25-MH31	LQ25-MH34	LQ25-MH46	LQ25-MH47	Leachate Tank	BIO 1	RISER 1	Composite
			Sep-20	Sep-20	Sep-20	Sep-20	Sep-20	Sep-20	Sep-20	Sep-20	Sep-20	Sep-20	Sep-20	Sep-20	Sep-20
Petroleum Hydrocarbons															
CCME Petroleum Hydrocarbon Fraction F1	mg/L	0.75	0.84	0.21	0.70	0.28	<0.10	0.37	<0.10	0.52	7.23	0.40	<0.10	0.28	
CCME Petroleum Hydrocarbon Fraction F2	mg/L	0.15	0.66	2.18	0.50	0.36	<0.10	0.45	0.10	0.33	0.25	0.38	<0.10	0.27	
CCME Petroleum Hydrocarbon Fraction F3	mg/L	0.50	0.35	99.4	<0.25	<0.25	<0.25	0.27	<0.25	<0.25	<0.25	<0.25	<0.25	0.32	
CCME Petroleum Hydrocarbon Fraction F4	mg/L	0.50	<0.25	17.9	<0.25	<0.25	<0.25	<0.25	<0.25	<0.25	<0.25	<0.25	<0.25	<0.25	
Volatile Organic Carbons															
Vinyl Chloride	mg/L	0.0017	0.0020	0.0008	0.0010	0.0009	<0.0005	0.0008	<0.0005	0.0029	0.0009	0.0005	<0.0005	0.0007	
1,4 Dichlorobenzene	mg/L	0.067	0.0107	0.0049	0.0104	0.0039	<0.0010	0.0069	<0.0010	0.0012	<0.0010	0.004	<0.00100	0.0015	
Chloroform	mg/L	0.022	<0.00050	<0.00050	<0.00050	<0.00050	<0.00050	<0.00050	<0.00050	<0.00050	<0.00050	<0.00050	<0.00050	<0.00050	
Trichloroethene	mg/L	0.017	<0.00050	<0.00050	<0.00050	<0.00050	<0.00050	<0.00050	<0.00050	<0.00050	0.00063	<0.00050	<0.00050	<0.00050	
Tetrachloroethene	mg/L	0.017	<0.00050	<0.00050	<0.00050	<0.00050	<0.00050	<0.00050	<0.00050	<0.00050	0.00397	<0.00050	<0.00050	<0.00050	
Dioxins and Furans															
2378 TeCDD	pg/L	14,000													<0.85
12378 PeCDD	pg/L	14,000													<0.70
123478 HxCDD	pg/L	14,000													<1.70
123678 HxCDD	pg/L	14,000													<1.60
123789 HxCDD	pg/L	14,000													<1.70
1234678 HpCDD	pg/L	14,000													48.1
OCDD	pg/L	14,000													482
Total TCDDs	pg/L	14,000													<0.85
Total PeCDD	pg/L	14,000													4.15
Total HxCDD	pg/L	14,000													6.2
Total HpCDD	pg/L	14,000													112
2378 TeCDF	pg/L	14,000													<0.67
12378 PeCDF	pg/L	14,000													<0.65
23478 PeCDF	pg/L	14,000													<0.57
123478 HxCDF	pg/L	14,000													<1.30
123678 HxCDF	pg/L	14,000													<1.30
123789 HxCDF	pg/L	14,000													<1.90
234678 HxCDF	pg/L	14,000													<1.40
1234678 HpCDF	pg/L	14,000													12.2
1234789 HpCDF	pg/L	14,000													<2.10
OCDF	pg/L	14,000													49.4
Total TCDF	pg/L	14,000													<0.67
Total PeCDF	pg/L	14,000													0.90
Total HxCDF	pg/L	14,000													2.50
Total HpCDF	pg/L	14,000													29.4
Polychlorinated Biphenyls															
Aroclor 1016	ug/L		<0.10	<1.0	<0.20	<0.20	<0.20	<0.36	<0.020	<0.130	<0.10	<0.310	<0.020	<0.240	
Aroclor 1221	ug/L		<0.10	<1.0	<0.20	<0.20	<0.20	<0.36	<0.020	<0.130	<0.10	<0.310	<0.020	<0.240	
Aroclor 1232	ug/L		<0.10	<1.0	<0.20	<0.20	<0.20	<0.36	<0.020	<0.130	<0.10	<0.310	<0.020	<0.240	
Aroclor 1242	ug/L		<0.10	13.4	0.75	0.27	<0.20	<0.36	<0.020	<0.130	<0.10	<0.310	<0.020	<0.240	
Aroclor 1248	ug/L		<0.10	<1.0	<0.20	<0.20	<0.20	<0.36	<0.020	<0.130	<0.10	<0.310	<0.020	<0.240	
Aroclor 1254	ug/L		<0.10	<1.0	<0.20	<0.20	<0.20	<0.06	<0.020	<0.060	<0.10	<0.040	<0.020	<0.060	
Aroclor 1260	ug/L		<0.10	<2.0	<0.40	<0.40	<0.20	<0.06	<0.020	<0.060	<0.10	<0.040	<0.020	<0.060	
Total PCBs	ug/L	15	<0.30	13.4	<0.85	<0.85	<0.06	<0.82	<0.060	<0.320	<0.30	<0.70	<0.060	<0.550	
Pesticides and Herbicides															
Diazinon	ug/L		<0.10	<62.0	<0.10	<0.10	<0.10	<0.10	<0.10	<0.10	<0.150	<0.10	<0.10	<0.40	
2, 4-D	mg/L		<0.0010	<0.0010	<0.0010	<0.0010	<0.0001	<0.0010	<0.0001	<0.0010	0.0415	0.0029	0.0011	<0.0010	
Aldrin	ug/L	8.5	<0.040	<0.040	<0.040	<0.040	<0.040	<0.040	<0.040	<0.040	<0.040	<0.040	<0.040	<0.040	
Hexachlorocyclohexane (Lindane)	ug/L	1.2	<0.040	<0.040	<0.150	<0.040	<0.040	<0.040	<0.040	<0.040	<0.040	<0.040	<0.040	<0.040	
MCPA	mg/L		<0.0010	<0.0010	<0.0010	<0.0010	<0.0001	<0.0010	<0.0001	<0.0010	0.0015	<0.0010	<0.0001	<0.0010	
Mirex	ug/L		<0.080	<0.40	<0.120	<0.120	<0.040	<0.20	<0.040	<0.240	<0.080	<0.40	<0.040	<0.080	
Methoxychlor	ug/L	6.5	<0.080	<0.80	<0.120	<0.120	<0.040	<0.20	<0.040	<0.240	<0.080	<0.40	<0.040	<0.080	
Bacteria															
Total Coliforms	MPN/100mL		>24,200	2,480	2,360	2,910	>24,200	8,660	488	3,870	>24,200	9,800	>2,420	3,080	
Fecal Coliforms	MPN/100mL		10	100	<10	<10	4,350	30	17	30	2,760	240	>2,420	10	
E. coli	MPN/100mL		<10	60	<10	<10	6,490	10	3	60	1,940	220	435	10	

Note: Criteria from Ontario Ministry of the Environment. (2011, July 1). Soil, Ground Water and Sediment Standards for Use Under Part XV.1 of the Environmental Protection Act Table 3: Full Depth Generic Site Condition Standards in a Non-Potable Ground Water Condition

Brady Road Resource Management Facility Annual Report – 2020

Water and Waste Eaux et déchets			<h3 style="margin: 0;">Table 9. 2020 Leachate Quality Comparison</h3>						
			2014	2015	2016	2017	2018	2019	2020
Sampling Date	Units	Criteria	Average	Average	Average	Average	Average	Average	Average
Field Parameters									
pH	units		NA	6.98	7.41	7.63	7.28	7.79	7.39
Turbidity - NTU	ntu		NA	21.4	37.9	119	298	166	77.0
Specific Conductivity	uS/cm		NA	6,493	4,278	9,046	10,580	8,663	10,160
Temperature	°C		NA	NA	NA	NA	13.8	13.9	11.5
Inorganic Parameters									
Alkalinity - Bicarbonate	mg/L		5,363	2,937	4,276	4,479	4,270	4,059	5,438
Alkalinity - Carbonate	mg/L		191	<5.0	130	<5.0	<3.0	<3.0	<3.0
Alkalinity - Hydroxide	mg/L		<5.0	<5.0	<5.0	<5.0	<3.0	<3.0	<3.0
Alkalinity - Total	mg/L		4,713	2,406	3,720	3,672	4,270	4,059	5,438
Hardness (as CaCO ₃)	mg/L		2,526	1,575	1,708	1,966	2,106	2704**	2,164
pH - units	units		7.29	7.57	7.24	7.35	7.06	7.24	7.33
Specific Conductivity	uS/cm		13,031	6,776	10,604	10,494	11,131	11,170	11,893
Turbidity - NTU	ntu		257	108	193	128	136	100	78.4
Total Dissolved Solids	mg/L		8,493	4,584	6,057	5,864	6,140	6,348	7,315
Total Suspended Solids	mg/L		1,327	245	13,543	579	789	635	374
Total Solids	mg/L		9,820	4,829	19,600	6,443	6,924	6,980	7,686
Chloride (dissolved)	mg/L	2300 *	1,757	744	1,060	1,222	1,163	2,183	1,456
Sulphate (dissolved)	mg/L		46	128	115	273	164	205	97
Other									
Cyanide (CN)	mg/L	0.066	0.013	0.010	0.010	0.008	0.021	0.014	0.011
Nutrients									
Dissolved Ammonia	mg/L		342	250	570	504	243	545	642
Nitrate Nitrogen	mg/L		0.237	0.159	0.310	1.35	8.48	1.01	1.75
Total Kjeldhal Nitrogen	mg/L		751	304	276	621	342	699	978
Phosphorus (Total)	mg/L		4.37	1.87	3.32	3.29	2.12	7.77	3.49
Organic Indicators									
Biological Oxygen Demand	mg/L		229	64	583	726	1,347	1,493	1,340
Chemical Oxygen Demand	mg/L		1,610	902	1,140	2,540	2,367	2,045	2,049
Metals									
Total Arsenic (As)	mg/L	1.9	0.0149	0.0115	0.0139	0.0248	0.0321	0.0220	0.0179
Total Barium (Ba)	mg/L	29	0.720	0.401	0.372	0.376	0.382	0.391	0.393
Total Beryllium (Be)	mg/L	0.067	<0.00005	0.03126	0.00014	0.00012	0.00113	<0.00003	<0.00003
Total Cadmium (Cd)	mg/L	0.0027	0.000320	0.000195	0.000307	0.000308	0.000452	<0.000007	<0.000007
Total Calcium (Ca)	mg/L		237	129	147	212	236	309	297
Total Chromium (Cr)	mg/L	0.81	0.0671	0.0315	0.0635	0.0724	0.0756	0.1354	0.1253
Total Chromium (Hexavalent)	mg/L		<0.0020	<0.0010	0.0050	0.0135	<0.010	<0.010	0.00068
Total Copper (Cu)	mg/L	0.087	0.0068	0.0080	0.0084	0.0128	0.0291	0.0218	0.0147
Total Iron (Fe)	mg/L		19.8	10.7	6.8	18.8	20.1	7.9	24.3
Total Lead (Pb)	mg/L	0.025	0.01682	0.00718	0.01072	0.01008	0.01057	0.00490	0.00345
Total Magnesium (Mg)	mg/L		469	248	279	329	368	469	345
Total Manganese (Mn)	mg/L		0.492	1.018	0.437	0.832	1.129	1.246	1.749
Total Mercury (Hg)	mg/L	0.0028	0.000020	0.000004	0.000002	0.000021	0.000023	0.000016	0.000031
Total Nickel (Ni)	mg/L	0.49	0.1713	0.1222	0.1546	0.1541	0.2522	0.2962	0.2481
Total Potassium (K)	mg/L		494	254	314	292	364	468	392
Dissolved Selenium (Se)	mg/L	0.063 *	0.00094	0.00102	0.00090	0.00120	0.00186	0.00137	0.00176
Total Silver (Ag)	mg/L	0.0015	0.000102	0.000095	0.000150	0.000090	0.000336	0.000095	0.000092
Total Sodium (Na)	mg/L	2,300	1,352	598	824	835	1,115	1,365	1,103
Total Zinc (Zn)	mg/L	1.1	0.589	0.055	1.18	0.453	0.206	0.530	0.263

Note: Criteria from Ontario Ministry of the Environment. (2011, July 1). Soil, Ground Water and Sediment Standards for Use Under Part XV.I of the Environmental Protection Act Table 3: Full Depth Generic Site Condition Standards in a Non-Potable Ground Water Condition

*Criteria for total chloride and total selenium

** Correction - results reported for 2019 were dissolved hardness

Brady Road Resource Management Facility Annual Report – 2020

 Water and Waste Eaux et déchets			Table 9. 2020 Leachate Quality Comparison						
			2014	2015	2016	2017	2018	2019	2020
Sampling Date	Units	Criteria	Average	Average	Average	Average	Average	Average	Average
Extractables									
Benzo (a) Pyrene (PAH)	mg/L	0.00081	0.00008	<0.00005	0.00079	0.00026	0.00075	0.00117	0.00031
Anthracene	mg/L	0.0024	0.00038	<0.00005	0.00105	0.00089	0.00133	0.00201	0.00101
4'4' Methylenebis 2 Chloroaniline	ug/L		NA	NA	NA	<5.0	<13.7	<5.0	<1.0
Benzo (a) anthracene (PAH)	mg/L	0.0047	0.00025	<0.00005	0.00123	0.00089	0.00113	0.00252	0.00010
Benzo (b/j) fluoroanthene (PAH)	mg/L		0.00026	<0.00005	0.00140	0.00049	0.00117	0.00166	0.00081
Benzo (g,h,i) Perylene (PAH)	mg/L	0.0002	0.00010	<0.00005	0.00073	0.00033	0.00103	0.00070	0.00017
Hexachlorobenzene	ug/L	3.1	<0.050	<0.050	<0.050	<0.050	<5.0	<5.0	<0.040
Phenanthrene	mg/L	0.58	NA	0.00062	0.00374	0.00205	0.00513	0.00748	0.00400
Phenol	mg/L	12	0.389	0.221	0.391	0.677	0.276	0.445	0.183
Petroleum Hydrocarbons									
CCME Petroleum Hydrocarbon Fraction F1	mg/L	0.75	3.88	0.19	0.11	0.45*	0.11	0.31	0.92
CCME Petroleum Hydrocarbon Fraction F2	mg/L	0.15	0.57	<0.10	0.17	0.23*	20.2	2.01	0.47
CCME Petroleum Hydrocarbon Fraction F3	mg/L	0.50	11.13	<0.20	<0.20	0.41*	371.2	12.3	8.45
CCME Petroleum Hydrocarbon Fraction F4	mg/L	0.50	1.56	<0.20	<0.20	<0.20	56.3	2.04	1.61
Volatile Organic Carbons									
Vinyl Chloride	mg/L	0.0017	<0.0050	<0.0050	<0.010	<0.0050	0.0005	0.0007	0.0009
1,4 Dichlorobenzene	mg/L	0.067	0.0055	0.0024	0.0051	0.0058	0.0022	0.0031	0.0038
Chloroform	mg/L	0.022	<0.0025	<0.0050	<0.0050	<0.0025	<0.00050	<0.00050	<0.00050
Trichloroethene	mg/L	0.017	<0.0050	<0.0050	<0.0050	<0.0025	0.00029	0.00053	<0.00050
Tetrachloroethene	mg/L	0.017	<0.0025	<0.0050	<0.0050	<0.0025	0.00039	<0.00050	0.00056
Polychlorinated Biphenyls									
Aroclor 1016	ug/L		<0.50	<0.50	<0.50	<0.50	<0.40	<8.0	<0.13
Aroclor 1221	ug/L		<0.50	<0.50	<0.50	<0.50	<0.40	<8.0	<0.13
Aroclor 1232	ug/L		<0.50	<0.50	<0.50	<0.50	<0.40	<8.0	<0.13
Aroclor 1242	ug/L		0.60	<0.50	0.12	<0.50	<1.5	<3.0	1.3
Aroclor 1248	ug/L		<0.50	<0.50	<0.50	<0.50	<0.40	<8.0	<0.13
Aroclor 1254	ug/L		<0.50	<0.50	0.10	<0.50	<2.0	<8.0	<0.10
Aroclor 1260	ug/L		<0.50	<0.50	0.10	<0.50	<2.0	<8.0	<0.20
Total PCBs	ug/L	15	0.64	<0.50	0.11	<0.50	<2.0	3.3	1.3
Pesticides and Herbicides									
Diazinon	ug/L		NA	<8	<8	<8*	<172	1.4	<62
2,4-D	mg/L		<0.004	<0.01	<2.0	<1.0	0.002	1.11	0.0041
Aldrin	ug/L	8.5	<0.05	<0.05	<0.05	<0.05	<2.25	<50	<0.040
gamma-Hexachlorocyclohexane (Lindane)	ug/L	1.2	<0.03	<0.03	<0.03	<0.03	<10	<50	<0.040
MCPA	mg/L		<0.008	<0.02	<4.0	<2.0	<0.005	<1.0	0.0005
Mirex	ug/L		<0.05	<0.05	<0.05	<0.05	<5.0	<50	<0.080
Methoxychlor	ug/L	6.5	<0.10	<0.10	<0.10	<0.10	<5.0	<50	<0.120
Bacteria									
Total Coliforms	MPN/100mL		4,254	141,751	4,859	6,158	15,448	18,210	9,056
Fecal Coliforms	MPN/100mL		1,718	144,943	323	243	3,211	5,033	831
E. coli	MPN/100mL		186	139,665	322	193	4,453	2,817	770
			Note: Criteria from Ontario Ministry of the Environment. (2011, July 1). Soil, Ground Water and Sediment Standards for Use Under Part XV.1 of the Environmental Protection Act Table 3: Full Depth Generic Site Condition Standards in a Non-Potable Ground Water Condition Note: NA - not analysed * Manhole 31 results not included in average due to pump malfunction						

BRADY ROAD RESOURCE MANAGEMENT FACILITY ANNUAL REPORT – 2020**5.4 LANDFILL GAS**

5.4.1 COLLECTION AND FLARING SYSTEM

Landfill gas (LFG) produced at the BRRMF is comprised primarily of methane (CH₄) and carbon dioxide (CO₂) in approximately equal amounts. These greenhouse gases contribute to global warming, but CH₄ has a global warming potential 25 times that of CO₂. To reduce emissions, the LFG is collected via a series of pipes beneath the BRRMF, and sent to a flare where the CH₄ is reduced to CO₂ and water vapor. The landfill gas collection and flaring system (LFGCFS) is run by Integrated Gas Recovery Systems Inc. on behalf of the City of Winnipeg.

As per the BRRMF Operating Plan, LFG operations and monitoring are managed through the Landfill Gas Operating Plan, submitted October 23, 2014, as per Clause 110.

In 2020, the BRRMF LFGCFS operated as intended, although surface emission monitoring identified some areas where gas was escaping due to weak surface cap and/or manholes with improper seals.

The 2020 Landfill Gas Collection and Flaring Report, prepared by Integrated Gas Recovery Services Inc., is attached in Appendix D.

5.4.2 SUBSURFACE LANDFILL GAS MONITORING PROGRAM

LFG that is not collected or that cannot escape into the atmosphere may migrate into neighboring land below the ground surface. The purpose of LFG migration monitoring is to detect gas migration before it becomes a safety hazard to neighboring properties.

As per the BRRMF Operating Plan, subsurface LFG migration is managed in accordance with the Subsurface Landfill Gas Monitoring Program, submitted on October 23, 2014, as specified under Clause 111. Probes are monitored monthly for methane (CH₄), oxygen (O₂), carbon monoxide (CO), and hydrogen sulphide (H₂S).

In 2020, the maximum level of CH₄ measured was 0.6%. The Subsurface Landfill Gas Contingency Plan was not activated, indicating that the LFGCFS is operating effectively.

The 2020 subsurface gas migration probe data is provided in Table 10.



Water and Waste
Eaux et déchets

Table 10. 2020 External Gas Probe Monitoring

Well No.	Date	CH4	O2	CO	H2S
		% LEL	(%)	PPM	PPM
1	20-Jan-20	0.1	19.6	0.0	1.0
1	14-Feb-20	0.0	21.6	0.0	0.0
1	4-Mar-20	0.0	21.4	0.0	0.0
1	7-Apr-20	0.0	21.5	0.0	0.0
1	6-May-20	0.0	20.1	0.0	0.0
1	22-Jun-20	0.0	20.2	0.0	0.0
1	15-Jul-20	0.0	20.9	1.0	0.0
1	19-Aug-20	0.0	21.2	0.0	0.0
1	21-Sep-20	0.0	20.0	0.0	0.0
1	27-Oct-20	0.0	21.6	0.0	0.0
1	20-Nov-20	0.0	20.8	0.0	0.0
1	30-Dec-20	0.1	20.7	0.0	0.0
2	20-Jan-20	0.1	19.7	0.0	1.0
2	14-Feb-20	0.0	22.0	0.0	0.0
2	5-Mar-20	0.0	21.2	0.0	0.0
2	7-Apr-20	0.0	20.3	0.0	0.0
2	6-May-20	0.0	20.3	0.0	0.0
2	22-Jun-20	0.0	19.6	0.0	0.0
2	15-Jul-20	0.0	20.7	1.0	0.0
2	19-Aug-20	0.0	20.2	0.0	0.0
2	21-Sep-20	0.0	20.2	0.0	0.0
2	27-Oct-20	0.0	21.6	0.0	0.0
2	20-Nov-20	0.0	20.8	0.0	0.0
2	30-Dec-20	0.1	20.8	0.0	0.0
3	20-Jan-20	0.1	20.0	0.0	0.0
3	14-Feb-20	0.0	20.9	0.0	0.0
3	4-Mar-20	0.0	21.4	0.0	0.0
3	7-Apr-20	0.0	20.6	0.0	0.0
3	6-May-20	0.0	20.7	0.0	0.0
3	22-Jun-20	0.0	20.3	0.0	0.0
3	15-Jul-20	0.0	20.9	1.0	0.0
3	19-Aug-20	0.0	20.4	0.0	0.0
3	21-Sep-20	0.0	20.5	0.0	0.0
3	27-Oct-20	0.0	21.4	0.0	0.0
3	20-Nov-20	0.0	20.6	0.0	0.0
3	30-Dec-20	0.1	21.2	0.0	0.0



Table 10. 2020 External Gas Probe Monitoring

Well No.	Date	CH4	O2	CO	H2S
		% LEL	(%)	PPM	PPM
4	20-Jan-20	no access			
4	14-Feb-20	0.0	20.9	0.0	0.0
4	4-Mar-20	0.0	20.4	0.0	0.0
4	7-Apr-20	0.0	20.5	0.0	0.0
4	6-May-20	0.0	20.8	0.0	0.0
4	22-Jun-20	0.0	20.1	0.0	0.0
4	15-Jul-20	0.0	20.7	1.0	0.0
4	19-Aug-20	0.0	20.4	0.0	0.0
4	21-Sep-20	0.0	20.4	0.0	0.0
4	27-Oct-20	0.0	21.3	0.0	0.0
4	20-Nov-20	0.0	20.2	0.0	0.0
4	30-Dec-20	0.2	20.9	0.0	0.0
5	20-Jan-20	no access			
5	14-Feb-20	0.6	19.7	0.0	0.0
5	4-Mar-20	0.0	16.7	0.0	0.0
5	7-Apr-20	0.0	17.3	0.0	0.0
5	6-May-20	0.0	20.3	0.0	0.0
5	22-Jun-20	0.0	17.6	0.0	0.0
5	15-Jul-20	0.0	20.7	1.0	0.0
5	19-Aug-20	0.0	17.8	0.0	0.0
5	21-Sep-20	0.0	20.5	0.0	0.0
5	27-Oct-20	0.0	21.5	0.0	0.0
5	20-Nov-20	0.0	20.3	0.0	0.0
5	30-Dec-20	0.1	21.0	0.0	0.0
6	20-Jan-20	0.0	19.7	0.0	1.0
6	14-Feb-20	0.5	18.3	0.0	0.0
6	4-Mar-20	0.0	19.9	0.0	79.9
6	7-Apr-20	0.0	20.9	0.0	0.0
6	6-May-20	0.0	20.9	0.0	0.0
6	22-Jun-20	0.0	20.5	0.0	0.0
6	15-Jul-20	0.0	20.9	1.0	0.0
6	19-Aug-20	0.0	19.8	0.0	0.0
6	21-Sep-20	0.0	20.4	0.0	0.0
6	27-Oct-20	0.0	21.2	0.0	0.0
6	20-Nov-20	0.0	21.5	0.0	0.0
6	30-Dec-20	0.1	22.0	0.0	0.0



Table 10. 2020 External Gas Probe Monitoring

Well No.	Date	CH4	O2	CO	H2S
		% LEL	(%)	PPM	PPM
7	20-Jan-20	0.0	20.4	0.0	0.0
7	14-Feb-20	0.4	22.1	0.0	0.0
7	4-Mar-20	0.0	18.3	0.0	0.0
7	7-Apr-20	0.0	21.1	0.0	0.0
7	6-May-20	0.0	20.9	0.0	0.0
7	22-Jun-20	0.0	18.4	0.0	0.0
7	15-Jul-20	0.0	20.7	1.0	0.0
7	19-Aug-20	0.0	19.7	0.0	0.0
7	21-Sep-20	0.0	20.2	0.0	0.0
7	27-Oct-20	0.0	21.2	0.0	0.0
7	20-Nov-20	0.0	21.2	0.0	0.0
7	30-Dec-20	0.1	23.0	0.0	0.0
8	20-Jan-20	0.0	20.5	0.0	0.0
8	14-Feb-20	0.5	22.1	0.0	0.0
8	4-Mar-20	0.0	21.2	0.0	0.0
8	7-Apr-20	0.0	21.1	0.0	0.0
8	6-May-20	0.0	20.9	0.0	0.0
8	22-Jun-20	0.0	16.7	0.0	0.0
8	15-Jul-20	0.0	20.9	1.0	0.0
8	19-Aug-20	0.0	20.9	0.0	0.0
8	21-Sep-20	0.0	20.0	0.0	0.0
8	27-Oct-20	0.0	21.3	0.0	0.0
8	20-Nov-20	0.0	21.5	0.0	0.0
8	30-Dec-20	0.1	22.7	0.0	0.0
9	20-Jan-20	0.1	17.6	0.0	0.0
9	14-Feb-20	no access			
9	4-Mar-20	0.0	18.3	0.0	0.0
9	7-Apr-20	0.0	14.5	0.0	0.0
9	6-May-20	0.0	20.9	0.0	0.0
9	22-Jun-20	0.0	18.0	0.0	0.0
9	15-Jul-20	0.0	20.7	1.0	0.0
9	19-Aug-20	0.0	18.7	0.0	0.0
9	21-Sep-20	0.0	20.0	0.0	0.0
9	27-Oct-20	0.0	21.6	0.0	0.0
9	20-Nov-20	0.0	21.5	0.0	0.0
9	30-Dec-20	0.1	22.4	0.0	0.0



Table 10. 2020 External Gas Probe Monitoring

Well No.	Date	CH4	O2	CO	H2S
		% LEL	(%)	PPM	PPM
10	20-Jan-20	0.1	20.4	0.0	0.0
10	14-Feb-20	0.4	21.4	0.0	0.0
10	4-Mar-20	0.0	20.9	0.0	0.0
10	7-Apr-20	no access			
10	6-May-20	0.0	20.9	0.0	0.0
10	22-Jun-20	0.0	20.9	0.0	0.0
10	15-Jul-20	0.0	20.9	1.0	0.0
10	19-Aug-20	0.0	20.9	0.0	0.0
10	21-Sep-20	0.0	20.4	0.0	0.0
10	27-Oct-20	0.0	20.1	0.0	0.0
10	20-Nov-20	0.0	21.1	0.0	0.0
10	30-Dec-20	0.1	22.2	0.0	0.0
P26E	20-Jan-20	no access			
P26E	14-Feb-20	0.0	22.0	0.0	0.0
P26E	4-Mar-20	0.0	17.6	0.0	0.0
P26E	7-Apr-20	0.0	16.8	0.0	0.0
P26E	6-May-20	0.0	20.4	0.0	0.0
P26E	22-Jun-20	0.0	17.2	0.0	0.0
P26E	15-Jul-20	0.0	17.7	1.0	0.0
P26E	19-Aug-20	0.0	17.2	0.0	0.0
P26E	21-Sep-20	0.0	20.4	0.0	0.0
P26E	27-Oct-20	0.0	20.7	0.0	0.0
P26E	20-Nov-20	0.0	21.3	0.0	0.0
P26E	30-Dec-20	0.1	22.5	0.0	0.0
P28E	20-Jan-20	0.1	20.6	0.0	0.0
P28E	14-Feb-20	0.0	16.1	0.0	0.0
P28E	4-Mar-20	0.0	14.9	0.0	0.0
P28E	7-Apr-20	0.0	13.8	0.0	0.0
P28E	6-May-20	0.0	20.0	0.0	0.0
P28E	22-Jun-20	0.0	19.3	0.0	0.0
P28E	15-Jul-20	0.0	20.9	1.0	0.0
P28E	19-Aug-20	0.0	17.1	0.0	0.0
P28E	21-Sep-20	0.0	20.0	0.0	0.0
P28E	27-Oct-20	0.0	20.0	0.0	0.0
P28E	20-Nov-20	0.0	21.3	0.0	0.0
P28E	30-Dec-20	0.1	23.1	0.0	0.0



Table 10. 2020 External Gas Probe Monitoring

Well No.	Date	CH4	O2	CO	H2S
		% LEL	(%)	PPM	PPM
P30E	20-Jan-20	0.1	21.8	0.0	2.0
P30E	14-Feb-20	0.4	22.9	1.0	0.0
P30E	4-Mar-20	0.0	7.6	0.0	0.0
P30E	7-Apr-20	0.0	8.9	0.0	0.0
P30E	6-May-20	0.0	20.2	0.0	0.0
P30E	22-Jun-20	0.0	18.3	1.0	0.0
P30E	15-Jul-20	0.0	20.9	1.0	0.0
P30E	19-Aug-20	0.0	19.6	0.0	0.0
P30E	21-Sep-20	0.0	20.2	0.0	0.0
P30E	27-Oct-20	0.0	21.0	0.0	0.0
P30E	20-Nov-20	0.0	21.5	0.0	0.0
P30E	30-Dec-20	0.1	20.9	0.0	0.0
P34E	20-Jan-20	0.4	21.7	0.0	2.0
P34E	14-Feb-20	0.0	22.1	0.0	0.0
P34E	5-Mar-20	0.0	22.3	0.0	0.0
P34E	7-Apr-20	0.1	20.4	0.0	0.0
P34E	6-May-20	0.0	19.6	0.0	0.0
P34E	22-Jun-20	0.0	20.9	0.0	0.0
P34E	15-Jul-20	0.0	20.9	1.0	0.0
P34E	19-Aug-20	0.0	20.4	0.0	0.0
P34E	21-Sep-20	0.0	19.6	0.0	0.0
P34E	27-Oct-20	0.0	20.8	0.0	0.0
P34E	20-Nov-20	0.0	21.6	0.0	0.0
P34E	30-Dec-20	0.1	20.4	0.0	0.0
P106E	20-Jan-20	0.0	21.9	0.0	0.0
P106E	14-Feb-20	0.4	20.3	0.0	0.0
P106E	4-Mar-20	0.0	20.9	0.0	0.0
P106E	7-Apr-20	0.0	20.9	1.0	0.0
P106E	6-May-20	0.0	20.9	0.0	0.0
P106E	22-Jun-20	0.0	20.9	0.0	0.0
P106E	15-Jul-20	0.0	20.9	1.0	0.0
P106E	17-Aug-20	0.0	16.2	0.0	1.0
P106E	21-Sep-20	0.0	19.9	0.0	0.0
P106E	27-Oct-20	0.0	20.4	0.0	0.0
P106E	20-Nov-20	0.0	20.9	0.0	0.0
P106E	30-Dec-20	0.1	20.9	0.0	0.0



Table 10. 2020 External Gas Probe Monitoring

Well No.	Date	CH4	O2	CO	H2S
		% LEL	(%)	PPM	PPM
P107E	20-Jan-20	0.0	21.8	0.0	0.0
P107E	14-Feb-20	0.4	21.2	0.0	0.0
P107E	4-Mar-20	0.0	19.9	0.0	0.0
P107E	7-Apr-20	0.0	19.3	1.0	0.0
P107E	6-May-20	0.0	20.7	0.0	0.0
P107E	22-Jun-20	0.0	20.3	0.0	0.0
P107E	15-Jul-20	0.0	20.7	1.0	0.0
P107E	17-Aug-20	0.0	19.9	0.0	0.0
P107E	21-Sep-20	0.0	20.3	0.0	0.0
P107E	27-Oct-20	0.0	20.7	0.0	0.0
P107E	20-Nov-20	0.0	20.7	0.0	0.0
P107E	30-Dec-20	0.0	21.2	0.0	0.0
P108E	20-Jan-20	0.0	21.8	0.0	0.0
P108E	14-Feb-20	0.4	22.2	0.0	0.0
P108E	4-Mar-20	0.0	21.3	0.0	0.0
P108E	7-Apr-20	0.0	21.1	1.0	0.0
P108E	6-May-20	0.0	20.6	0.0	0.0
P108E	22-Jun-20	0.0	20.3	0.0	0.0
P108E	15-Jul-20	0.0	20.9	1.0	0.0
P108E	17-Aug-20	0.0	19.3	0.0	0.0
P108E	21-Sep-20	0.0	20.3	0.0	0.0
P108E	27-Oct-20	0.0	20.9	0.0	0.0
P108E	20-Nov-20	0.0	21.3	0.0	0.0
P108E	30-Dec-20	0.1	21.3	0.0	0.0
P109E	20-Jan-20	0.0	21.7	0.0	0.0
P109E	14-Feb-20	0.5	22.0	0.0	0.0
P109E	4-Mar-20	0.0	21.2	0.0	0.0
P109E	7-Apr-20	0.0	19.9	0.0	0.0
P109E	6-May-20	0.0	20.6	0.0	0.0
P109E	22-Jun-20	0.0	20.3	0.0	0.0
P109E	15-Jul-20	0.0	20.7	1.0	0.0
P109E	17-Aug-20	0.0	19.2	0.0	0.0
P109E	21-Sep-20	0.0	19.4	0.0	0.0
P109E	27-Oct-20	0.0	20.0	0.0	0.0
P109E	20-Nov-20	0.0	21.4	0.0	0.0
P109E	30-Dec-20	0.1	21.5	0.0	0.0



Table 10. 2020 External Gas Probe Monitoring

Well No.	Date	CH4	O2	CO	H2S
		% LEL	(%)	PPM	PPM
P110E	20-Jan-20	0.0	21.5	0.0	0.0
P110E	14-Feb-20	0.5	4.5	0.0	0.0
P110E	4-Mar-20	0.0	4.1	0.0	0.0
P110E	7-Apr-20	0.0	4.4	2.0	0.0
P110E	6-May-20	0.0	20.7	0.0	0.0
P110E	22-Jun-20	0.0	1.8	1.0	0.0
P110E	15-Jul-20	0.0	20.9	1.0	0.0
P110E	17-Aug-20	0.0	6.8	0.0	1.0
P110E	21-Sep-20	0.0	6.9	0.0	0.0
P110E	27-Oct-20	0.0	6.6	0.0	0.0
P110E	20-Nov-20	0.0	6.5	0.0	0.0
P110E	30-Dec-20	0.1	1.5	0.0	0.0
P111E	20-Jan-20	0.0	20.8	0.0	0.0
P111E	14-Feb-20	0.2	20.4	0.0	0.0
P111E	4-Mar-20	0.0	20.7	0.0	0.0
P111E	7-Apr-20	0.0	21.2	0.0	0.0
P111E	6-May-20	0.0	20.6	0.0	0.0
P111E	22-Jun-20	0.0	20.9	0.0	0.0
P111E	15-Jul-20	0.0	20.7	1.0	0.0
P111E	17-Aug-20	0.0	19.8	0.0	0.0
P111E	21-Sep-20	0.0	20.7	0.0	0.0
P111E	27-Oct-20	0.0	21.3	0.0	0.0
P111E	20-Nov-20	0.0	20.9	0.0	0.0
P111E	30-Dec-20	0.1	20.7	0.0	0.0
P112E	20-Jan-20	0.0	20.6	0.0	0.0
P112E	14-Feb-20	0.4	20.2	0.0	0.0
P112E	4-Mar-20	0.0	21.3	0.0	0.0
P112E	7-Apr-20	0.0	21.3	0.0	0.0
P112E	6-May-20	0.0	20.7	0.0	0.0
P112E	22-Jun-20	0.0	20.9	0.0	0.0
P112E	15-Jul-20	0.0	20.7	1.0	0.0
P112E	17-Aug-20	0.0	19.7	0.0	0.0
P112E	21-Sep-20	0.0	20.7	0.0	0.0
P112E	27-Oct-20	0.0	21.6	0.0	0.0
P112E	20-Nov-20	no access			
P112E	30-Dec-20	no access			

BRADY ROAD RESOURCE MANAGEMENT FACILITY ANNUAL REPORT – 2020

6.0 NUISANCE MANAGEMENT

In order to reduce odour, litter, and vector nuisances at the landfill, several best practices and operating procedures are used, such as placement of screens, minimizing the working face of each cell, application of appropriate cover material (daily, intermediate, or final), site landscaping, weekly litter control patrols, and odour monitoring. If necessary, a licensed professional will apply vector control products to ensure that proper chemicals are used and properly handled. Noise is not a significant issue due to the separation from surrounding homes. Fugitive dust emissions are minimized by spraying site roads with uncontaminated surface water.

In 2020, there were 21 odour complaints from 15 customers; in all cases the source of the odour was investigated. If the source of the odour could be located within the BRRMF, we immediately covered the odour causing material, moved the tipping face to a more favorable area if available, and used compost or wood chips to reduce the odour and prevent further occurrence. Table 11 provides a summary of nuisance complaints received in 2020.

Brady Road Resource Management Facility Annual Report – 2020

Date Created	Complaint	Response
Odours		
1/3/2020	Citizen emailed in to report that the Brady Landfill smells very rancid at the moment and that the smell needs to be addressed. Please attend.	Responded to the resident stating that there have been some complications with operations in the past week, and with the warmer weather and atmospheric conditions, it is possible the odour was from Brady Landfill. Stated that we continuously work to reduce the impact of the landfill on our community and listed the measures that we take to control odours in and around our landfill on a day to day basis.
1/13/2020	Citizen reported on Jan 13 'The odour issues have been continuing in a moderate though still noticeable way. This evening it is substantially higher with a phosphorus type smell.	Responded to the resident stating that Brady did have an odour the previous day and with the atmospheric conditions the odour is likely to have travelled in that direction. Explained to the resident that the current garbage cell is getting close to the end of its capacity which would also contribute to the odour. Stated that the new cell will be opening and accepting waste; so the existing hill will provide some protection and relief from the odour. Also mentioned that Brady has been handling the biosolids on site for the last month, but the soil fabrication project was starting back up Monday, and this should also help lessen the odour.
2/16/2020	Citizen reported on Jan 13 'The odour issues have been continuing in a moderate though still noticeable way. This evening it is substantially higher with a phosphorus type smell.	Responded to the resident stating that the atmospheric conditions on Sunday suggest that the odour may have originated at Brady landfill. Unfortunately, with the right wind conditions it is very difficult to contain the odour, given our current operating location. Explained that we are working to close the current garbage cell and open a new cell further south, this will hopefully help to control some of the odour. Also mentioned that we have also started up our soil fabrication project that is diverting all biosolids from Brady, this should greatly reduce the odour for the foreseeable future.
3/13/2020	Citizen states that there is a substantial odour around brady landfill. Please inspect. Thank you.	Responded to the resident stating that the atmospheric conditions today suggest that the odour could not have originated at Brady landfill. The wind for the last 24 hours has been coming from a strong WNW direction, thus the odour would be pushed away from that residence. Explained that we continue to monitor the odour in an around the landfill and will continue to monitor your area for the foreseeable future. Added that we are working to try to reduce odour and have started a project to improve our landfill gas system. Hopefully this will result in a reduction in odour issues.
6/21/2020	Citizen states; "There is a very bad smell outside which I believe is coming from Brady landfill. During winter, smell is pretty frequent which is very unfortunate and during summer, it is a bit better. But this is an on and off unpredictable scenario. It's embarrassing when visitors are over and they question the smell. I hope city will do something about the smell."	Responded to the resident stating that the atmospheric conditions and current landfill operations suggest that it would be likely the odour originated from Brady Landfill. Currently Brady is working on expanding the landfill gas collection system which has caused an increase in the hydrogen sulfide "garbage" odour that is emitted from Brady. Stated that we continuously work to reduce the impact of the landfill on our community and listed the measures that we take to control odours in and around our landfill on a day to day basis. Mentioned that we have also started up our soil fabrication project that is diverting all biosolids from Brady, this should greatly reduce the odour for the foreseeable future.
6/27/2020	Citizen states that the odour from Brady landfill has become very strong in the last 3 days	Responded to the resident stating that the atmospheric conditions and current landfill operations suggest that it would be likely the odour originated from Brady Landfill. Currently Brady is working on expanding the landfill gas collection system which has caused an increase in the hydrogen sulfide "garbage" odour that is emitted from Brady. Stated that we continuously work to reduce the impact of the landfill on our community and listed the measures that we take to control odours in and around our landfill on a day to day basis. Mentioned that we have also started up our soil fabrication project that is diverting all biosolids from Brady, this should greatly reduce the odour for the foreseeable future.
7/4/2020	Citizen emailed 311 wanting to file a complaint regarding the odour coming from the landfill. They state that they noticed an extreme odour on July 1st around 9:45pm. They live on Lake Bend Road, and they could not sit outside for Canada Day due to the odour. They also requested information on how they control odours if possible.	Responded to the resident stating that the atmospheric conditions and current landfill operations suggest that it would be likely the odour originated from Brady Landfill. Currently Brady is working on expanding the landfill gas collection system which has caused an increase in the hydrogen sulfide "garbage" odour that is emitted from Brady. Stated that we continuously work to reduce the impact of the landfill on our community and listed the measures that we take to control odours in and around our landfill on a day to day basis. Mentioned that we have also started up our soil fabrication project that is diverting all biosolids from Brady, this should greatly reduce the odour for the foreseeable future.
7/7/2020	Citizen emailed 311 stating that the odour from the landfill was extremely bad on Canada Day, and was very bad this past Wednesday as well.	Responded to the resident stating that the atmospheric conditions and current landfill operations suggest that it would be likely the odour originated from Brady Landfill. Currently Brady is working on expanding the landfill gas collection system which has caused an increase in the hydrogen sulfide "garbage" odour that is emitted from Brady. Stated that we continuously work to reduce the impact of the landfill on our community and listed the measures that we take to control odours in and around our landfill on a day to day basis. Mentioned that we have also started up our soil fabrication project that is diverting all biosolids from Brady, this should greatly reduce the odour for the foreseeable future.

Client File No. 5556.00

Manitoba Environment Act Licence No. 3081 R

Brady Road Resource Management Facility Annual Report – 2020

Date Created	Complaint	Response
Odours		
7/11/2020	Citizen reported substantial odour that smells like garbage on Wednesday, July 8th. Citizen states they are no longer experiencing it now but would still want to have this issue investigated.	<p>Responded to the resident stating that the atmospheric conditions and current landfill operations suggest that it would be likely the odour originated from Brady Landfill. Currently Brady is working on expanding the landfill gas collection system which has caused an increase in the hydrogen sulfide "garbage" odour that is emitted from Brady.</p> <p>Stated that we continuously work to reduce the impact of the landfill on our community and listed the measures that we take to control odours in and around our landfill on a day to day basis.</p> <p>Mentioned that we have also started up our soil fabrication project that is diverting all biosolids from Brady, this should greatly reduce the odour for the foreseeable future.</p>
7/13/2020	Resident states they live in Bridgewater Trails. Resident states that since the weather became hot they can smell a heavy odour everyday. Resident states the smell in the air made the family confused and their son has recently developed a cough. Resident would like to know if it is normal to smell this every day, if the odour is dangerous, if there are any solutions to control the odour, and if they will have to smell the odour the whole year.	<p>Responded to the resident stating that the atmospheric conditions and current landfill operations suggest that it would be likely the odour originated from Brady Landfill. Currently Brady is working on expanding the landfill gas collection system which has caused an increase in the hydrogen sulfide "garbage" odour that is emitted from Brady.</p> <p>Stated that we continuously work to reduce the impact of the landfill on our community and listed the measures that we take to control odours in and around our landfill on a day to day basis.</p> <p>Mentioned that we have also started up our soil fabrication project that is diverting all biosolids from Brady, this should greatly reduce the odour for the foreseeable future.</p>
7/15/2020	Resident would like further actions taken by the COW to resolve this ongoing odor issue. She would also like to know why this is happening so consistently. Ther resident previously logged a complaint regarding the Brady landfill smell. "It is a beautiful summer day today, but unfortunately there is no way to enjoy the weather outside due to the smell. This is the third time in a week I'm experiencing a strong smell and I didn't even bother logging a complaint for the second incident. Is there any particular reason to get the smell consistently? It is so unfortunate to spend so much money on a house and not having the ability to enjoy the time outside. I got a response from the city regarding the initiatives they have taken to address this. But I really hope city will do something about this sooner than later as this is unhealthy, annoying as well as embarrassing to have friends over when your area smells like a dump."	<p>Responded to the resident stating that recently there have been unfavorable atmospheric conditions and landfill operations that have contributed to an increase in odour coming from the landfill. On days that there is a South wind it is more likely that the odour will be noticed. As well, the landfill is still working to expand their gas collection system which will continue into September. They are doing as much as they can to mitigate odour from this project.</p> <p>Also explained that three times a week our team conducts an odour round at Brady as well as the in the surrounding communities to test for Hydrogen Sulfide. So far we have not detected any harmful levels around your residence. We will continue to monitor levels around the neighborhood on a weekly basis.</p>
7/15/2020	Citizen said the odor coming from the dump tonight is really, really bad. Please look into. Thank you.	<p>Responded to the resident stating that the atmospheric conditions and current landfill operations suggest that it would be likely the odour originated from Brady Landfill. Currently Brady is working on expanding the landfill gas collection system which has caused an increase in the hydrogen sulfide "garbage" odour that is emitted from Brady.</p> <p>Stated that we continuously work to reduce the impact of the landfill on our community and listed the measures that we take to control odours in and around our landfill on a day to day basis.</p> <p>Mentioned that we have also started up our soil fabrication project that is diverting all biosolids from Brady, this should greatly reduce the odour for the foreseeable future.</p>
7/16/2020	Email in: "We can smell the landfill again this evening (July 16th). It's been very disappointing how frequently we can smell the dump this summer."	<p>Responded to the resident stating that the atmospheric conditions and current landfill operations suggest that it would be likely the odour originated from Brady Landfill. Currently Brady is working on expanding the landfill gas collection system which has caused an increase in the hydrogen sulfide "garbage" odour that is emitted from Brady.</p> <p>Stated that we continuously work to reduce the impact of the landfill on our community and listed the measures that we take to control odours in and around our landfill on a day to day basis.</p> <p>Mentioned that we have also started up our soil fabrication project that is diverting all biosolids from Brady, this should greatly reduce the odour for the foreseeable future.</p>
7/20/2020	Resident states that for the last couple of months there has been a strong odour in the air in the South Pointe neighbourhood, which they attribute to the Brady Landfill. Resident would like action taken to prevent this, because they say that "It is becoming unbearable to either open the windows or step out of the home" and they fear that there could be health consequences.	<p>Responded to the resident stating that the atmospheric conditions and current landfill operations suggest that it would be likely the odour originated from Brady Landfill. Currently Brady is working on expanding the landfill gas collection system which has caused an increase in the hydrogen sulfide "garbage" odour that is emitted from Brady.</p> <p>Stated that we continuously work to reduce the impact of the landfill on our community and listed the measures that we take to control odours in and around our landfill on a day to day basis.</p> <p>Mentioned that we have also started up our soil fabrication project that is diverting all biosolids from Brady, this should greatly reduce the odour for the foreseeable future.</p>
7/24/2020	Caller reports an intense odour coming from the Brady Landfill tonight.	<p>Responded to the resident stating that the atmospheric conditions and current landfill operations suggest that it would be likely the odour originated from Brady Landfill. Currently Brady is working on expanding the landfill gas collection system which has caused an increase in the hydrogen sulfide "garbage" odour that is emitted from Brady.</p> <p>Stated that we continuously work to reduce the impact of the landfill on our community and listed the measures that we take to control odours in and around our landfill on a day to day basis.</p> <p>Mentioned that we have also started up our soil fabrication project that is diverting all biosolids from Brady, this should greatly reduce the odour for the foreseeable future.</p>

Brady Road Resource Management Facility Annual Report – 2020

Date Created	Complaint	Response
Odours		
8/5/2020	Resident reports a high concentration of what she believes to be hydrogen sulfide coming from the landfill on Wednesday, 24 June and again on Tuesday, 4 August, 2020.	<p>Responded to the resident stating that the atmospheric conditions and current landfill operations suggest that it would be likely the odour originated from Brady Landfill. Currently Brady is working on expanding the landfill gas collection system which has caused an increase in the hydrogen sulfide "garbage" odour that is emitted from Brady.</p> <p>Stated that we continuously work to reduce the impact of the landfill on our community and listed the measures that we take to control odours in and around our landfill on a day to day basis.</p> <p>Mentioned that we have also started up our soil fabrication project that is diverting all biosolids from Brady, this should greatly reduce the odour for the foreseeable future.</p>
8/5/2020	<p>Citizen reports that the odour coming from Brady today is unhealthy and intolerable. This has been a concern for the past 3 years that he has lived at his address. He cannot sit outside and there are children that he is concerned may become ill due to the odour.</p> <p>Citizen reports that the smell is very strong early today</p>	<p>Responded to the resident stating that the atmospheric conditions and current landfill operations suggest that it would be likely the odour originated from Brady Landfill. Currently Brady is working on expanding the landfill gas collection system which has caused an increase in the hydrogen sulfide "garbage" odour that is emitted from Brady.</p> <p>Stated that we continuously work to reduce the impact of the landfill on our community and listed the measures that we take to control odours in and around our landfill on a day to day basis.</p> <p>Mentioned that we have also started up our soil fabrication project that is diverting all biosolids from Brady, this should greatly reduce the odour for the foreseeable future.</p>
8/6/2020	Councillor's office is following up on behalf of the constituent. The resident states other neighbours have also noticed the strong smell coming from the landfill. Councillor office is requesting further information on the issue, including if anything has been done about the odour.	<p>Responded to the resident stating that the atmospheric conditions and current landfill operations suggest that it would be likely the odour originated from Brady Landfill. Currently Brady is working on expanding the landfill gas collection system which has caused an increase in the hydrogen sulfide "garbage" odour that is emitted from Brady.</p> <p>Stated that we continuously work to reduce the impact of the landfill on our community and listed the measures that we take to control odours in and around our landfill on a day to day basis.</p> <p>Mentioned that we have also started up our soil fabrication project that is diverting all biosolids from Brady, this should greatly reduce the odour for the foreseeable future.</p>
8/6/2020	<p>Citizen is complaining about the odours coming from Brady Land fill. He said that he can't even go outside this summer because the smell is so bad.</p> <p>Citizen would like someone to contact him either by phone or by e-mail.</p>	<p>Responded to the resident stating that the atmospheric conditions and current landfill operations suggest that it would be likely the odour originated from Brady Landfill. Currently Brady is working on expanding the landfill gas collection system which has caused an increase in the hydrogen sulfide "garbage" odour that is emitted from Brady.</p> <p>Stated that we continuously work to reduce the impact of the landfill on our community and listed the measures that we take to control odours in and around our landfill on a day to day basis.</p> <p>Mentioned that we have also started up our soil fabrication project that is diverting all biosolids from Brady, this should greatly reduce the odour for the foreseeable future.</p>
8/25/2020	<p>Citizen stated that she has been smelling a nasty odour/smoke from the Brady landfill and this is the fourth night that this is happening. It smells like manure and it is really bad that she cannot sit outside. She stated that this had happened in the past</p>	<p>Responded to the resident stating that the atmospheric conditions and current landfill operations suggest that it would be likely the odour originated from Brady Landfill. Currently Brady is working on expanding the landfill gas collection system which has caused an increase in the hydrogen sulfide "garbage" odour that is emitted from Brady.</p> <p>Stated that we continuously work to reduce the impact of the landfill on our community and listed the measures that we take to control odours in and around our landfill on a day to day basis.</p> <p>Mentioned that we have also started up our soil fabrication project that is diverting all biosolids from Brady, this should greatly reduce the odour for the foreseeable future.</p>
9/25/2020	<p>Received at councillor office yesterday:</p> <p>"Today is Sept 24 and a beautiful day.</p> <p>WHAT IS THAT HORRIBLE SMELL WAFTING THROUGH WAVERLEY HEIGHTS, BRIDGEWATER SOUTH POINT ETC.</p> <p>This is not a 'garbage dump' smell but more like pig or fertilizer. We thought something was being done about the Samborski fertilizer operation. What is this and everyone around here is noticing it, but I am probably the only one complaining. Are there plans to alleviate this stench?"</p>	<p>Responded to the resident stating that the atmospheric conditions and current landfill operations suggest that it would be likely the odour originated from Brady Landfill. Currently Brady is working on expanding the landfill gas collection system which has caused an increase in the hydrogen sulfide "garbage" odour that is emitted from Brady.</p> <p>Stated that we continuously work to reduce the impact of the landfill on our community and listed the measures that we take to control odours in and around our landfill on a day to day basis.</p> <p>Mentioned that we have also started up our soil fabrication project that is diverting all biosolids from Brady, this should greatly reduce the odour for the foreseeable future.</p>

BRADY ROAD RESOURCE MANAGEMENT FACILITY ANNUAL REPORT – 2020

7.0 CONCLUSION

The diversion operations taking place at the BRRMF have been effective in diverting tens of thousands of metric tonnes of material from the landfill.

Leachate management was successful in 2020 as there were no breakouts of leachate.

The quality of the ground water beneath the site has not been negatively impacted, as demonstrated by the comparison of upstream to downstream ground water quality.

The quality of the surface water measured at the Weir is statistically similar to the quality of the surface water upstream of the BRRMF.

The areas where landfill gas is escaping will be repaired by upgrading the cap in those areas potentially using biosolid fabricated soil.

The BRRMF will continue to operate so as to ensure that the environment is maintained in such a manner as to sustain a high quality of life, including social and economic development, recreation and leisure for present and future Manitobans.

8.0 REFERENCES

1. Brady Road Resource Management Facility – Manitoba Environment Act Licence No. 3081 R

<https://www.winnipeg.ca/waterandwaste/pdfs/garbage/bradylicence.pdf>

2. Ontario Ministry of the Environment. (2011, July 1). Soil, Ground Water and Sediment Standards for Use Under Part XV.1 of the Environmental Protection Act. Table 3: Full Depth Generic Site Condition Standards in a Non-Potable Ground Water Condition.

<https://www.ontario.ca/page/soil-ground-water-and-sediment-standards-use-under-part-xv1-environmental-protection-act>

3. Canadian Council of Ministers of the Environment. Canadian Environmental Quality Guidelines Summary Table. Water Quality Guidelines for the Protection of Freshwater Aquatic Life. (CCME, 2019).

<http://cegg-rcqe.ccme.ca/download/en/221>

FIGURE 1
BRRMF LAYOUT & LEACHATE
COLLECTION SYSTEM

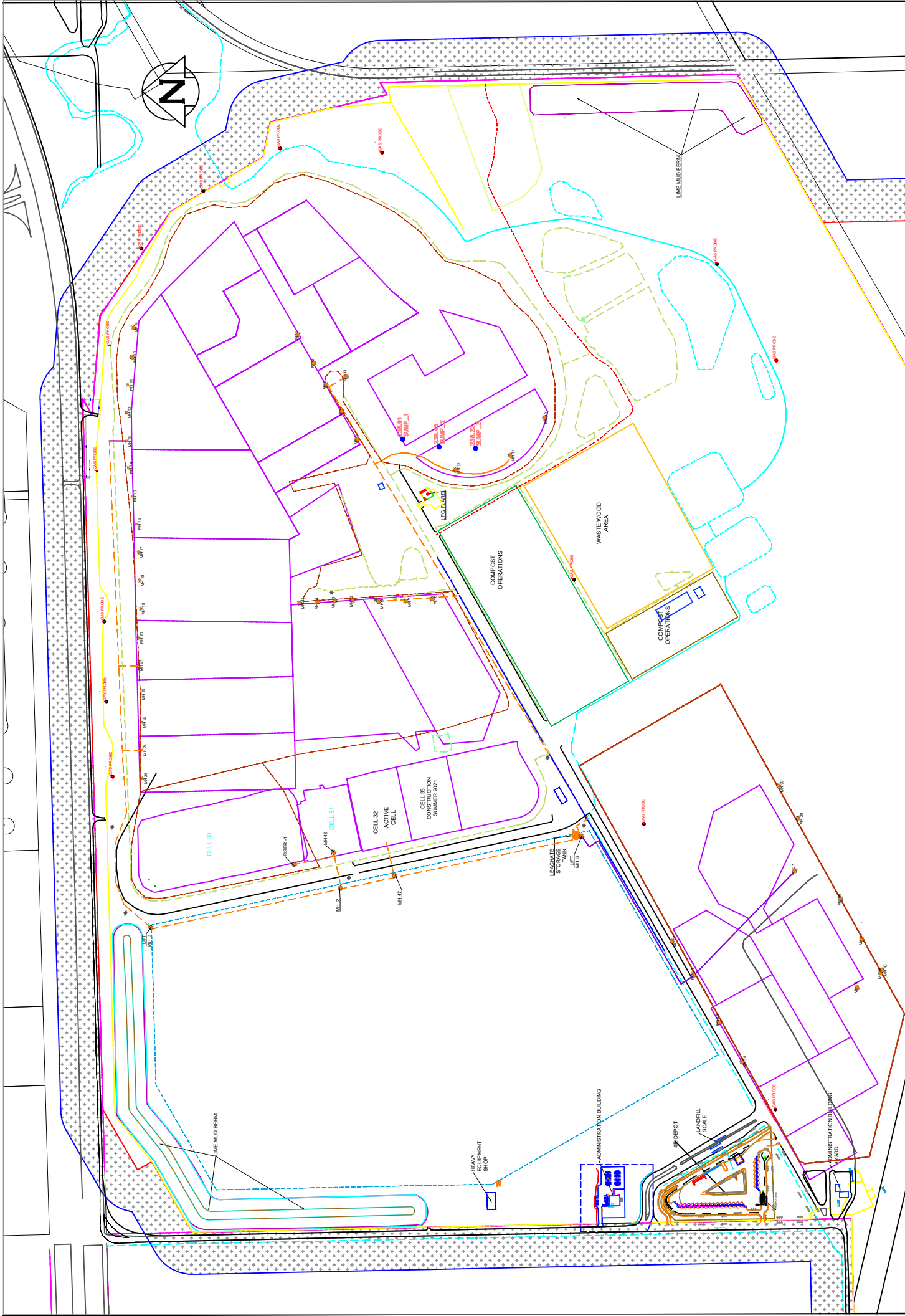

DATE	BY	REVISION
12/15/2020	GR	ISSUED FOR PERMITTING
04/12/2021	GR	REVISED FOR PERMITTING

PROJECT: BRRMF ADMINISTRATIVE BUILDING
 DRAWING NO: 2021-001
 DATE: April 12, 2021
 SCALE: 1:10
 SHEET NO: 25
 CITY DRAWING NUMBER: BRRMF-AdminBldg-WW-2021-001

DATE	BY	REVISION
12/15/2020	GR	ISSUED FOR PERMITTING
04/12/2021	GR	REVISED FOR PERMITTING

PROJECT: BRRMF ADMINISTRATIVE BUILDING
 DRAWING NO: 2021-001
 DATE: April 12, 2021
 SCALE: 1:10
 SHEET NO: 25
 CITY DRAWING NUMBER: BRRMF-AdminBldg-WW-2021-001

Scale in metres / Échelle en mètres

M E T R I C / M É T R I Q U E
 0 10 20 30 40 50 60 70 80 90 100
 METRES / MÈTRES

LEGEND/LEGENDE

- CONTROL ZONE / Zone de contrôle
- ADMIN. BUILDING
- LANDFILL SITE / Site d'enfouissement
- CONTOURS LINES @ 0.05m
- MANHOLE
- GW Flow Direction
- LEACHATE PROBE
- HEAVY EQUIPMENT STOP
- LEACHATE STORAGE TANK
- WATER TOWER
- WASTEWATER SYSTEM
- STORM DRAIN SYSTEM
- RAILWAY
- GW WELLS

La Ville de Winnipeg
 City of Winnipeg

 BRADY RD.

FIGURE 2
GROUND WATER SAMPLING
LOCATIONS

BRADY ROAD LANDFILL



LEGEND

- ▲ OVERBURDEN PIEZOMETER NEST
- GROUNDWATER WELL



B.M. ELEV.	FIELD BOOK #
POSTED TO LIBS	
1	11/11/25 KB
NO. REVISIONS	DATE BY



THE CITY OF WINNIPEG
WATER AND WASTE DEPARTMENT

BRADY ROAD LANDFILL
WELL LOCATIONS

SHEET 1 of 1

FIGURE 1_R1

FIGURE 3
SURFACE WATER SAMPLING
LOCATIONS

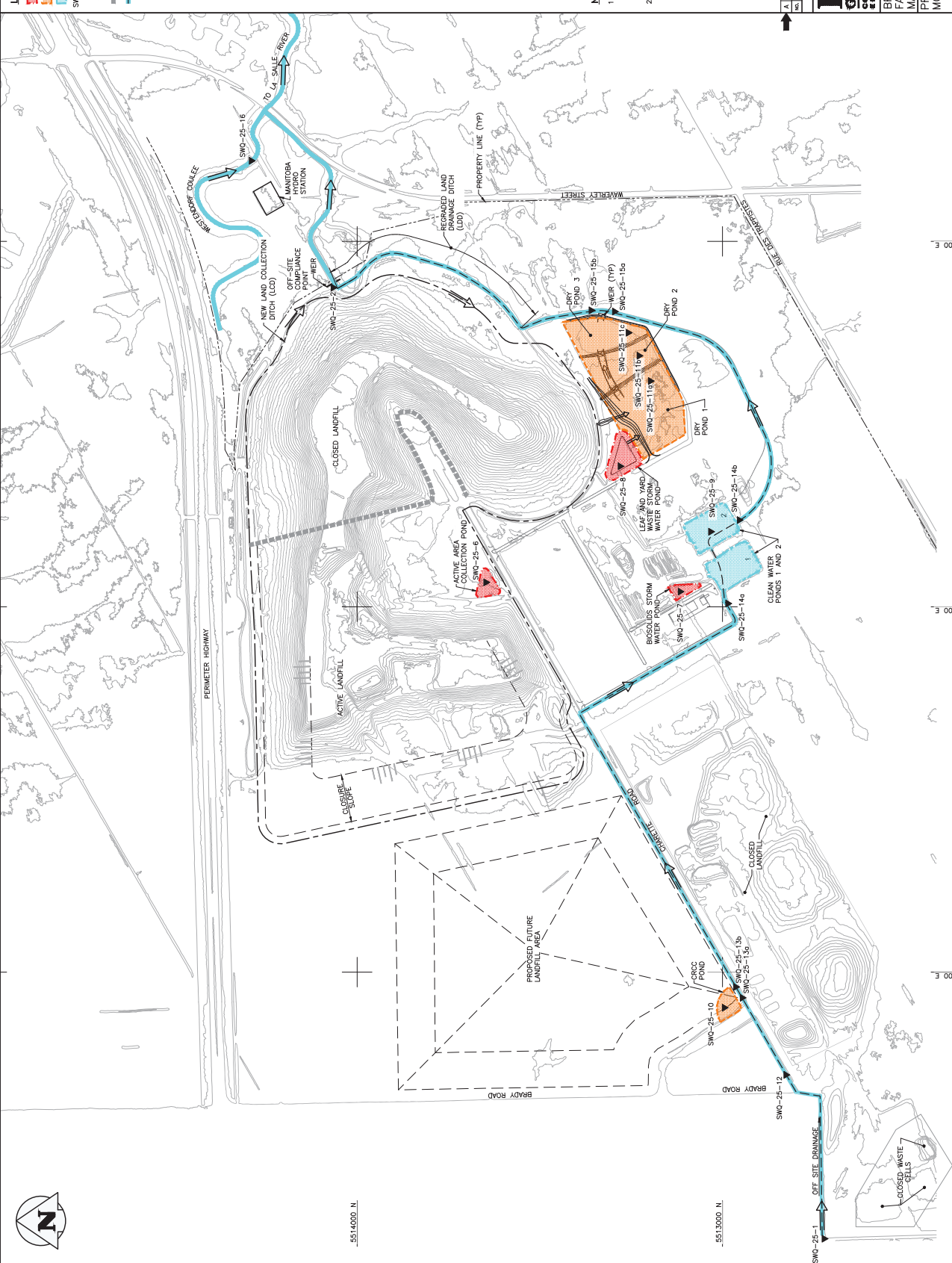

LEGEND:

- IMPACTED WATER POND
- DRY POND
- CLEAN WATER POND
- SURFACE WATER SAMPLING LOCATION
- SURFACE WATER FLOW DIRECTION
- CLOSED LANDFILL BOUNDARY
- LAND DRAINAGE DITCH

SWO-25-16

NOTES:

- GEOGRAPHY SOURCES ARE CITY OF WINNIPEG, KGS CONSULTING ENGINEERS AND ADDITIONAL LANDFILL OPERATING AREA AND ADDITIONAL LANDFILL PERIMETER SURVEY BY KGS GROUP 2013.
- EXACT SURFACE WATER SAMPLING LOCATION TO BE DETERMINED IN FIELD.



NO.	DATE	REVISIONS / ISSUE

KGS GROUP
CONSULTING ENGINEERS

THE CITY OF WINNIPEG
WATER AND WASTEWATER

BRADY ROAD RESOURCE MANAGEMENT
FACILITY SURFACE WATER
MANAGEMENT PLAN
PROPOSED SURFACE WATER
MONITORING LOCATIONS

APPENDIX A
2020 BRRMF TONNAGE
SPREADSHEET

CITY OF WINNIPEG: Brady Road Resource Management Facility Tonnage (metric tonnes) 2020

Material Type	WW Material	Item/Acct	January	February	March	April	May	June	July	August	September	October	November	December	Total
Domestic Collection - AREA 1-MILLER	DOM REF CT	2400	5004.00	4068.16	5030.83	6922.44	7164.11	7413.39	7391.57	6499.82	6706.25	6078.04	5365.54	5320.84	72,964.99
Domestic Collection - AREA 2-GFL	DOM REF CT	2500	4461.42	3613.30	4507.27	6124.65	6081.67	6338.75	6320.95	5719.25	5827.12	5439.75	4868.64	4807.48	64,110.25
Domestic Collection - BULKY PU-WASTE CONNECTION	DOM REF CT	3500	47.65	40.00	41.36	101.35	189.52	187.93	168.53	171.35	154.65	97.10	67.49	77.70	1,344.63
Other	DOM REF CT	*		0.00	0.00	2.99	0.00	0.00	9.85	-9.85			-2.99	0.00	0.00
Subtotal Single Family Collection	DOM REF CT		9,513.07	7,721.46	9,579.46	13,151.43	13,435.30	13,940.07	13,890.90	12,380.57	12,688.02	11,614.89	10,298.68	10,206.02	138,419.87
Multi-Family NW Area - Miller Waste Systems	APT WT	1093	1766.75	1487.88	1806.70	2144.25	2235.19	2431.68	2428.51	2220.96	2209.28	2012.37	1830.98	1895.85	24,470.40
Multi-Family SW Area - Waste Connections	APT WT	1504	1206.30	1044.55	1371.30	1585.28	1583.48	1721.29	1808.87	1550.99	1512.02	1393.88	1126.78	1137.15	17,041.89
Multi-Family E Area - Waste Connections	APT WT	1519	1103.06	859.60	1000.09	1104.99	1231.91	1341.60	1142.94	1187.52	1175.31	1150.00	9.26	0.00	11,306.28
Multi-Family E Area - GFL (Rolloff)	APT WT	1520		38.81	43.60	85.03	107.87	87.17	95.85	88.00	80.17	85.28	63.20	52.99	827.97
Multi-Family E Area - GFL (Front End)	APT WT	1553											1237.18	1258.67	2,495.85
Other	APT WT	*	1.52		3.53	-2.21	1.41	0.00	0.00	0.00	4.26	-4.26	-4.25	7.57	7.57
Subtotal Apt Collection	APT WT		4,077.63	3,430.84	4,225.22	4,917.34	5,159.86	5,581.74	5,476.17	5,047.47	4,981.04	4,637.27	4,263.15	4,352.23	56,149.96
Total Residential Collection			13,590.70	11,152.30	13,804.68	18,068.77	18,595.16	19,521.81	19,367.07	17,428.04	17,669.06	16,252.16	14,561.83	14,558.25	194,569.83
City Refuse - eg. Street Cleaning	CITY REFUS	4	141.37	162.75	478.40	700.79	1696.86	1033.64	3678.02	1726.81	862.31	2432.93	707.08	699.93	14,320.89
Construction / Demolition Waste - City	CITY CNDEM	5	1379.14	114.17	8.51	157.18	490.77	369.16	99.77	81.26	26.79	4.00	0.00	0.00	2,730.75
Landscaping - City - trees, etc., & (DE)	TREELFCITY	6													
	TREES CITY														
	TREES DE 1		479.93	474.74	669.00	309.10	231.14	272.08	162.36	118.51	64.52	274.94	444.97	397.77	3,899.06
Grit	GRIT	7	244.38	207.97	275.40	215.27	214.97	255.56	247.84	137.22	169.21	112.42	111.78	155.76	2,347.78
Bio solids landfilled	SLUDGE		2833.02	0.00	0.00	2382.73	3286.84	4859.29	3362.93	0.00	0.00	0.00	0.00	0.00	16,724.81
Waste Diversion Residue	RECYC-REFU						0.25	0.00	2.01	0.00	0.00	0.00	0.00	0.00	2.26
Residue from MRF (EMTERRA)	RESIDUE		0.00	0.00	0.00	0.00	0.00	0.00	0.00	0.00	0.00	0.00	0.00	0.00	0.00
Sweepings	SWEEP		0.21	0.00	0.00	-0.21	104.52	394.46	451.01	13.28	0.00	8300.45	0.00	5.23	9,268.95
Total City Depts - Charged			5,078.05	959.63	1,431.31	3,764.86	6,025.35	7,184.19	8,001.93	2,079.09	1,122.83	11,124.74	1,263.83	1,258.69	49,294.50
Total Residential + City Depts			18,668.75	12,111.93	15,235.99	21,833.63	24,620.51	26,706.00	27,369.00	19,507.13	18,791.89	27,376.90	15,825.66	15,816.94	243,864.33
Dead Animals-Charge	ANIMAL WAS	8													
	ANIMLS-CHG														
	SRM		618.11	843.29	729.19	859.35	650.99	797.33	896.41	867.55	995.52	1213.15	1333.01	878.48	10,682.38
Asbestos	ASBESTOS	9	20.68	28.00	31.65	165.88	45.04	51.33	17.22	51.74	57.20	5.47	23.81	10.18	508.20
Charitable Organization - C / special rate	C-CHARITY	18	141.85	115.68	102.04	123.76	109.58	165.70	194.32	196.00	172.16	190.47	132.33	118.87	1,762.76
Commercial / Industrial - all sources	COMM/INDUS	10	4544.83	3675.56	4562.83	5322.36	6958.72	6969.91	7332.29	6613.56	7193.96	5837.21	5010.58	4004.88	68,026.69
Commercial Flat Fee	COMM_FF		17.32	276.80	263.87	11.17	21.56	23.15	18.80	13.52	29.78	185.18	33.36	68.70	963.21
Construction / Demolition Waste	CONST/DEM	11	0.00	0.00	0.00	0.00	0.00	0.00	0.00	0.00	0.00	0.00	0.00	0.00	0.00
Concrete - charged	CONC - CHG	12	0.64	0.00	0.00	1.61	0.00	4.83	0.00	0.00	0.00	1.25	3.75	0.00	12.08
Hospital Waste	HOSP WASTE	13	0.34	0.50	0.81	0.54	0.96	0.51	0.76	0.83	0.53	0.37	0.55	1.01	7.71
	LANDSCAPE														
	TREELFCOMM														
	TREES COMM														
Landscaping - Com. - trees, etc., & (DE)	TREES DE 2	14	2.23	7.36	11.93	8.06	52.26	62.77	24.79	16.05	50.87	52.31	15.40	6.00	310.03
Residue - Canada Fiber	RESIDUE-CF		711.19	444.60	545.41	648.69	775.49	766.39	723.49	698.62	720.84	662.80	626.17	652.00	7,975.69
Sawdust - Charged	SAWDUST CH	15	0.00	0.00	0.00	0.00	0.00	0.00	0.00	0.00	0.00	0.00	0.00	0.00	0.00
	HYDRO POLE														
	RES/OVER														
	SANDBAG														
	TIRES														
	TOILETS_\$5														
	TOILETS_CH														
Special Waste	WEEDS	17	0.00	0.00	0.00	0.00	0.00	0.00	0.00	0.00	0.00	0.00	0.00	0.00	0.00
Sewer Grit	SEWER-GRIT		0.00	0.00	0.00	0.00	0.00	0.00	0.00	0.00	0.00	0.00	0.00	0.00	0.00
Manure	MANURE-P	16	0.00	0.00	0.00	0.00	121.92	0.00	0.00	0.00	0.00	0.00	0.00	0.00	121.92
Total Non City Depts - Charged			6,057.19	5,391.79	6,247.73	7,141.42	8,736.52	8,841.92	9,208.08	8,457.87	9,220.86	8,148.21	7,178.96	5,740.12	90,370.67
Dead Animals - TFW	ANIMLS-N/C	20	0.80	0.24	0.70	1.38	1.07	0.55	1.34	0.81	1.35	0.92	2.95	0.88	12.99
Brady Admin Building Construction Material	1777 BRADY		0.00	0.00	0.00	0.00	0.00	0.00	0.00	0.00	0.00	0.00	0.00	0.00	0.00
Charitable Organization - TFW	CHARITY	19	76.78	47.05	25.13	99.84	31.12	28.99	65.60	66.19	61.66	69.42	41.56	50.35	663.69
October Fall Storm Wood Waste- NC (City and Private)	C-TREE-EMG		0.00	0.00	0.00	0.00	0.00	0.00	0.00	0.00	0.00	0.00	0.00	0.00	0.00
Neighbourhood clean ups	CLEAN-UP		0.00	0.00	0.00	0.00	6.02	0.00	2.43	0.00	9.35	0.00	0.00	0.00	17.80
Total Non City Depts - Not Charged			77.58	47.29	25.83	101.22	38.21	29.54	69.37	67.00	72.36	70.34	44.51	51.23	694.48
Total Non City Depts			6,134.77	5,439.08	6,273.56	7,242.64	8,774.73	8,871.46	9,277.45	8,524.87	9,293.22	8,218.55	7,223.47	5,791.35	91,065.15

Material Type	WW Material	Item/Acct	January	February	March	April	May	June	July	August	September	October	November	December	Total
NUMBER OF VEHICLES / LOADS															
Description		Item/Acct	January	February	March	April	May	June	July	August	September	October	November	December	Total
BRADY ROAD LANDFILL - VEHICLES / LOADS															
Vehicles - Domestic Refuse - City		1	0	0	0	0	0	0	0	0	0	0	0	0	0
Vehicles - Domestic Refuse - Contract	DOM REF CT	2	1414	1201	1348	1496	1527	1542	1552	1412	1459	1457	1355	1493	17,256
Vehicles - 4R Depot (Brady) - Garbage Area	DATA LINK V by T		2375	2448	3914	6766	11003	8879	8379	8278	8098	7985	5918	3671	77,714
Vehicles - 4R Depot (Brady) - Total			3280	3249	5009	10521	17596	15108	13416	12316	12948	12335	8669	5070	119,517
Vehicles - 4R Depot (Pacific)			1628	1492	1696	3589	7087	5983	5812	5385	5488	5897	3766	2239	50,062
Vehicles - 4R Depot (Panet)			3074	2639	2873	5865	10747	10479	9322	7985	8678	9573	6206	4143	81,584
Vehicles - Commercial / Industrial	COMM/INDUS	10	2995	2754	3418	3717	5367	5203	5349	5098	5390	4952	4256	3239	51,738
Vehicles - Special Waste		17	0	0	0	0	0	0	0	0	0	0	0	0	0
Vehicles - Mud Trucks - Tandems			52	153	52	95	13	0	0	0	0	0	0	0	365
Vehicles - Mud Trucks - Semi-Trailers			0	3	7	42	3	0	0	0	0	0	0	0	55
OTHER MUNICIPALITIES - VEHICLES / LOADS															
Manitoba Conservation (Falcon Lake)		772	0	0	0	0	0	0	0	0	0	0	0	0	0
RM of Tache		886	0	0	0	0	0	0	0	0	0	0	0	0	0
R.M. of MacDonald / Blackhawk Enterprises		1127	0	0	0	0	0	0	0	0	0	0	0	0	0
R. M. of Springfield / Emterra		1212	0	0	0	0	0	0	0	0	0	0	0	0	0
R. M. of West St.Paul / Emterra		1263	0	0	0	0	0	0	0	0	0	0	0	0	0
TOTAL VEHICLES - ALL PAYING CUSTOMERS			14,818	13,939	18,317	32,091	53,343	47,194	43,830	40,474	42,061	42,199	30,170	19,855	320,577

Reconcile Monthly Tonnage to WasteWorks Material Analysis report		Blue font = formula = don't type in													Total
Total Actual Weight per WW		January	February	March	April	May	June	July	August	September	October	November	December	Total	
		31,062.30	23,030.03	27,131.40	39,838.25	65,241.82	73,645.53	78,408.06	49,648.21	55,792.85	60,171.68	44,528.97	39,592.50	588,091.60	
Less: Removals X 2 (negative here but positive in WW)		0.00	0.00	0.00	0.00	0.00	0.00	0.00	0.00	0.00	0.00	0.00	0.00	0.00	
(BATTERYRMV)		0.00	0.00	0.00	0.00	(123.34)	(1.06)	0.00	0.00	(528.48)	0.00	0.00	(130.02)	(782.90)	
(COMPOSTREM)		0.00	0.00	0.00	0.00	0.00	0.00	0.00	0.00	0.00	0.00	0.00	0.00	0.00	
(GLASS REMV)		(5,258.80)	(4,292.28)	(4,103.08)	(8,288.74)	(8,444.14)	(8,501.08)	(7,221.32)	(6,263.60)	(7,556.74)	(6,865.78)	(7,367.76)	(5,621.94)	(79,785.26)	
(LEACH REMV)		0.00	0.00	0.00	0.00	0.00	0.00	0.00	0.00	0.00	0.00	0.00	0.00	0.00	
(ODS REMOVA)		0.00	0.00	0.00	0.00	0.00	0.00	0.00	0.00	0.00	0.00	0.00	0.00	0.00	
(SCRAP REMV)		0.00	0.00	0.00	0.00	0.00	0.00	0.00	0.00	0.00	0.00	0.00	0.00	0.00	
(TREESDE-WA)		0.00	0.00	0.00	0.00	0.00	0.00	0.00	0.00	0.00	0.00	0.00	0.00	0.00	
(TIRES REMV)		338.00	1,059.00	488.50	1,520.50	149.00	0.00	0.00	0.00	0.00	0.00	0.00	0.00	3,555.00	
MUD TRUCKS MANULLY TRAC		0.00	0.00	0.00	0.00	0.00	0.00	0.00	0.00	0.00	0.00	0.00	0.00	0.00	
Less: Items not on tonnage report		0.00	(76.32)					(228.49)	(4.69)		(33.04)			(342.54)	
RES/REFUSE															
WEIGH ONLY				(0.65)		(0.12)				(0.01)	(1.12)	(3.53)		(5.43)	
TEST														0.00	
4RDEPTFF WASTEWORCS RE														0.00	
4RDEPTFF WRARS LEVY REP														0.00	
4R MATERIALS		125.67	95.88	142.40	198.95	370.58	411.24	393.14	340.23	376.38	365.71	298.24	1,294.93	4,413.35	
COMM_FF WASTEWORCS RE														0.00	
COMM_FF WRARS LEVY REPO														0.00	
ZRATE ADJ		0.00	0.00	0.00	0.00	0.00	0.00	0.00	0.00	0.00	0.00	0.00	0.00	0.00	
CASH CUSTOMER		0.00	0.00	0.00	0.00	0.00	0.00	0.00	0.00	0.00	0.00	0.00	0.00	0.00	
OTHER ADJUSTMENTS					(0.09)									(0.09)	
ACCT 472 ARSON PILOT ZONE		0.00	0.00	0.00	0.00	0.00	0.00	0.00	0.00	0.00	0.00	0.00	0.00	0.00	
Net		26,267.17	19,816.31	23,658.57	33,268.87	57,193.80	65,554.63	71,351.39	43,720.15	48,084.00	53,637.45	37,455.92	35,135.47	515,143.73	
Total per Tonnage Report		26,267.17	19,816.31	23,658.57	33,268.87	57,193.80	65,554.63	71,351.39	43,720.15	48,084.00	53,637.45	37,455.92	35,135.47	515,143.73	
Difference should be zero		0.00	0.00	0.00	0.00	0.00	0.00	0.00	0.00	0.00	0.00	0.00	0.00	0.00	

APPENDIX B
2020 PIPER DIAGRAMS

**2020 GROUNDWATER
PIPER DIAGRAMS**

Site: Brady

Location : GWQ25-4N34-CR

Dates:
 8-Jun-16
 30-May-17
 4-Jun-18
 16-May-19
 8-Jun-20

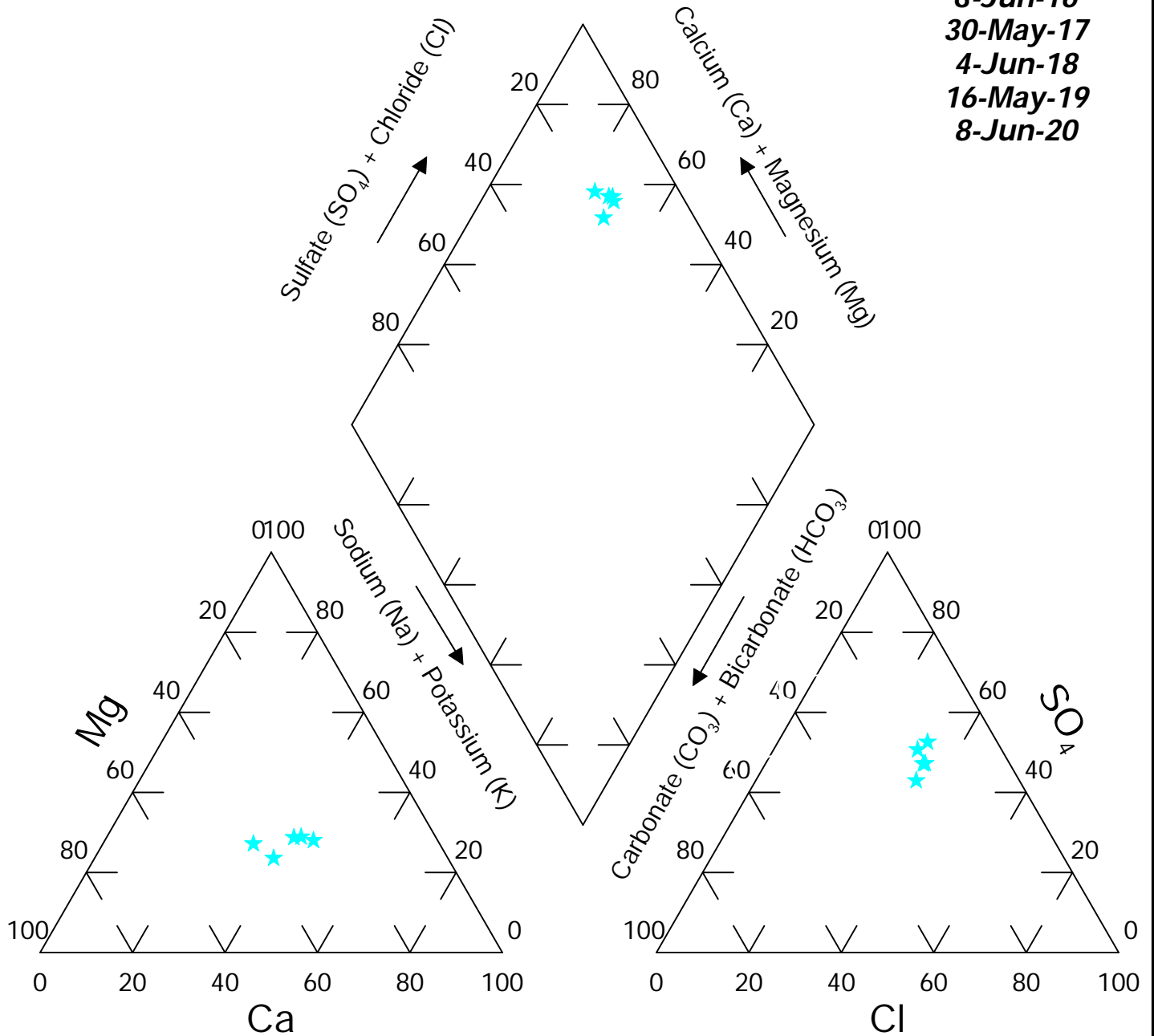

Site: Brady

Location : GWQ25-5N62-D

Dates:
 4-Jun-15
 30-May-16
 29-May-17
 31-May-18
 22-May-19
 4-Jun-20

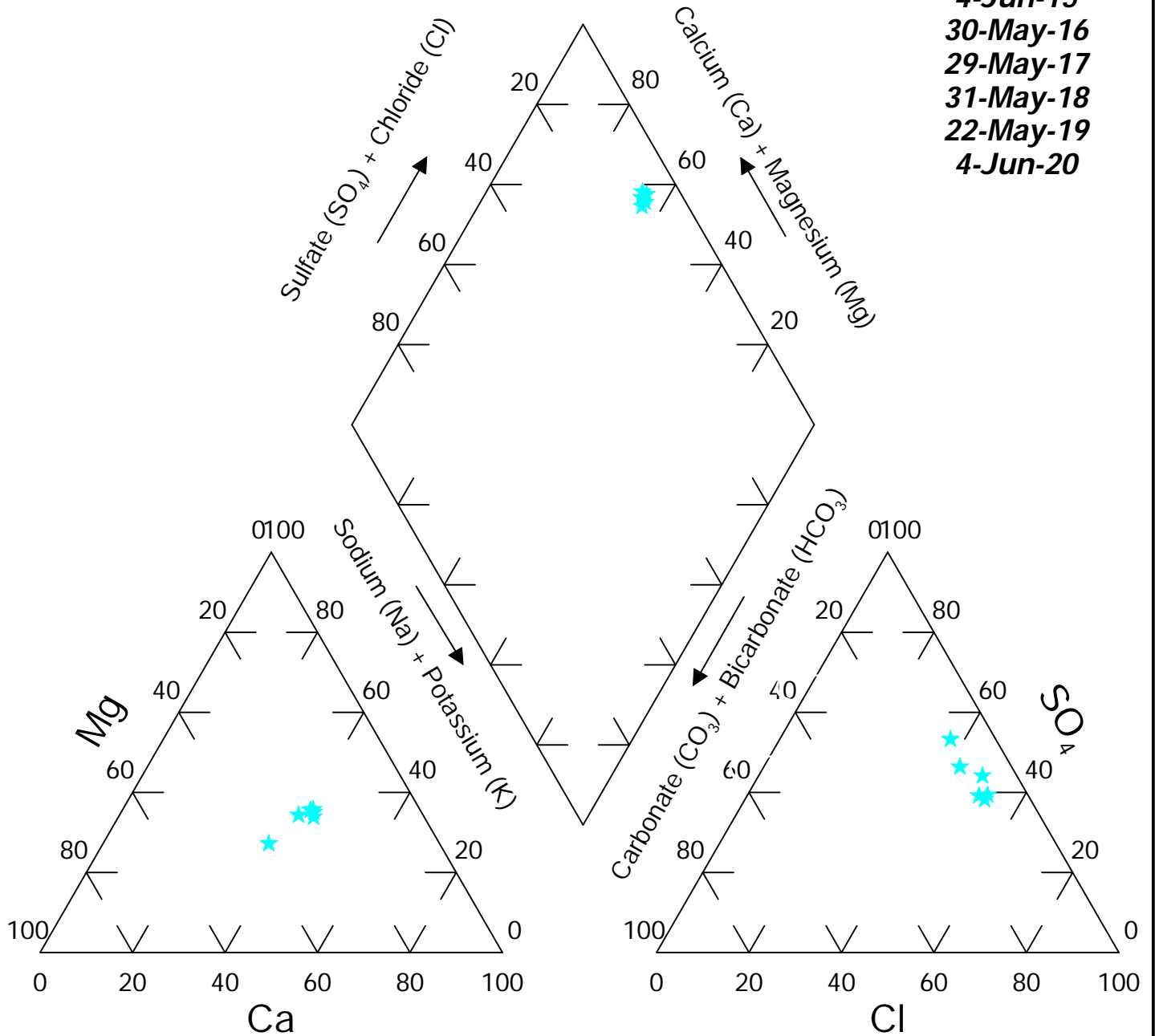

Site: Brady

Location : GWQ25-6N57-DR

Dates:

- 4-Jun-15
- 26-May-16
- 29-May-17
- 31-May-18
- 21-May-19
- 8-Jun-20

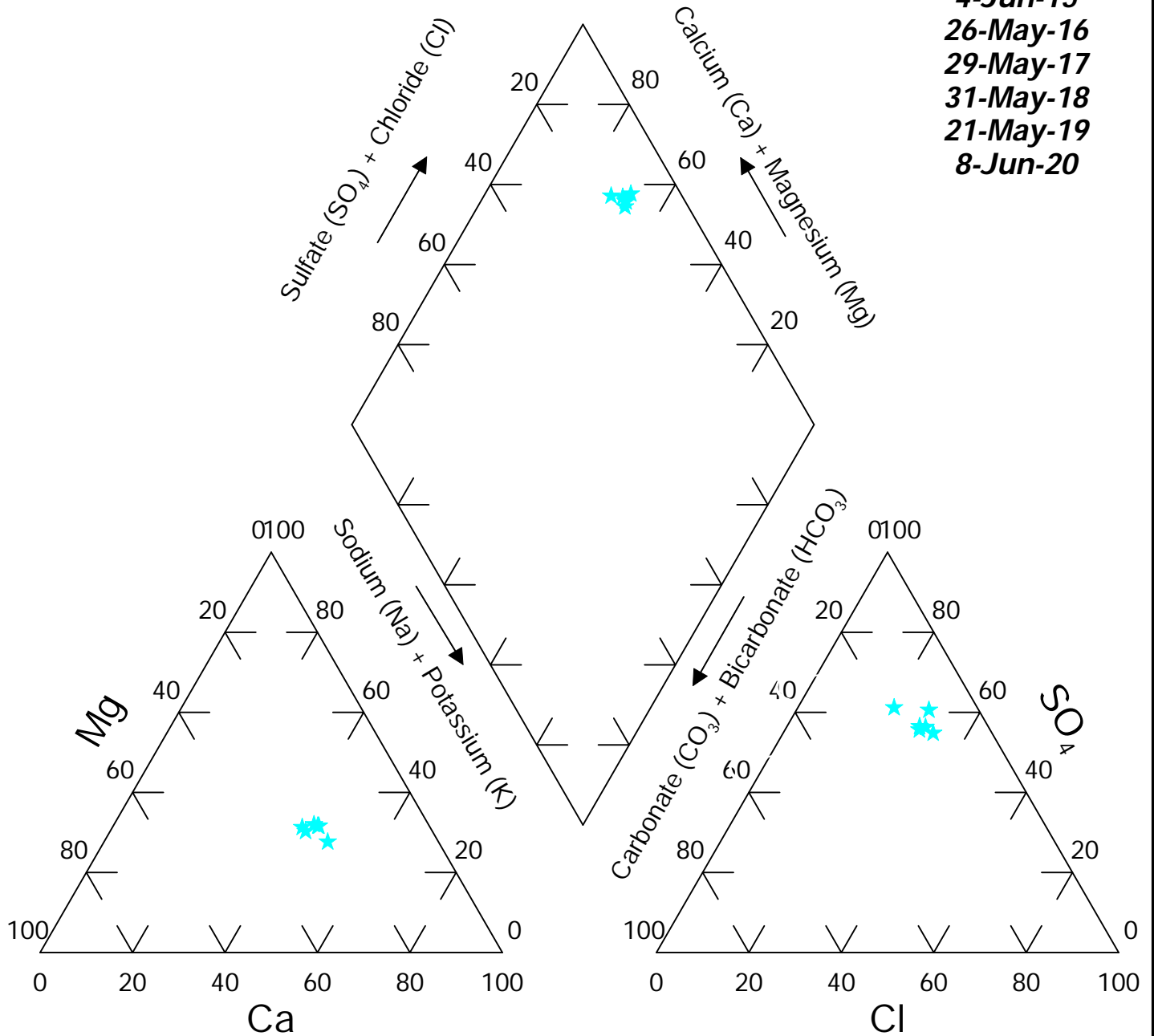

Site: Brady

Location : GWQ25-6N58-DR

Dates:
8-Jun-15
31-May-16
31-May-18
9-Jun-20

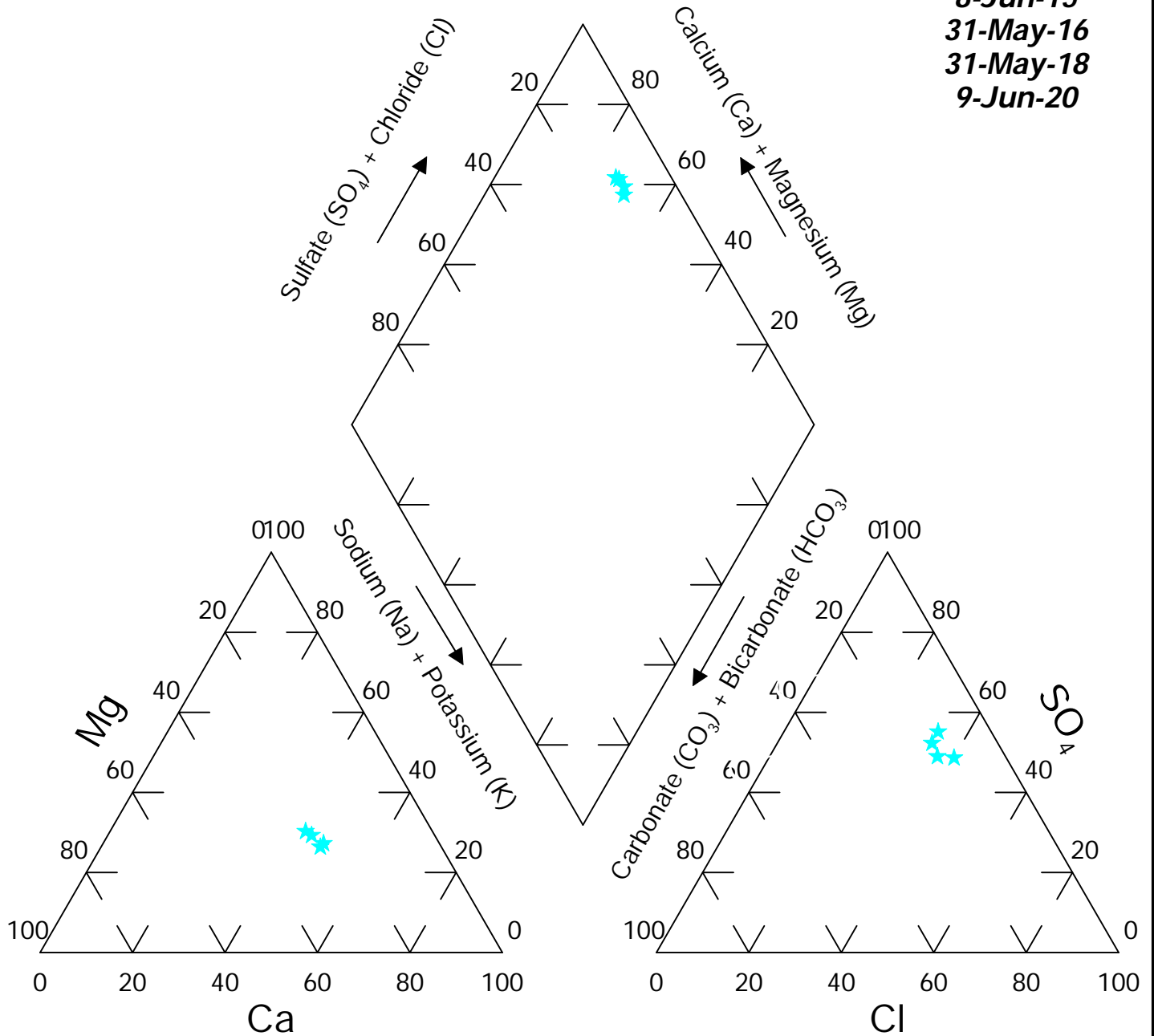

Site: Brady

Location : GWQ25-6N59-DR

Dates:
9-Jun-15
31-May-16
30-May-18
9-Jun-20

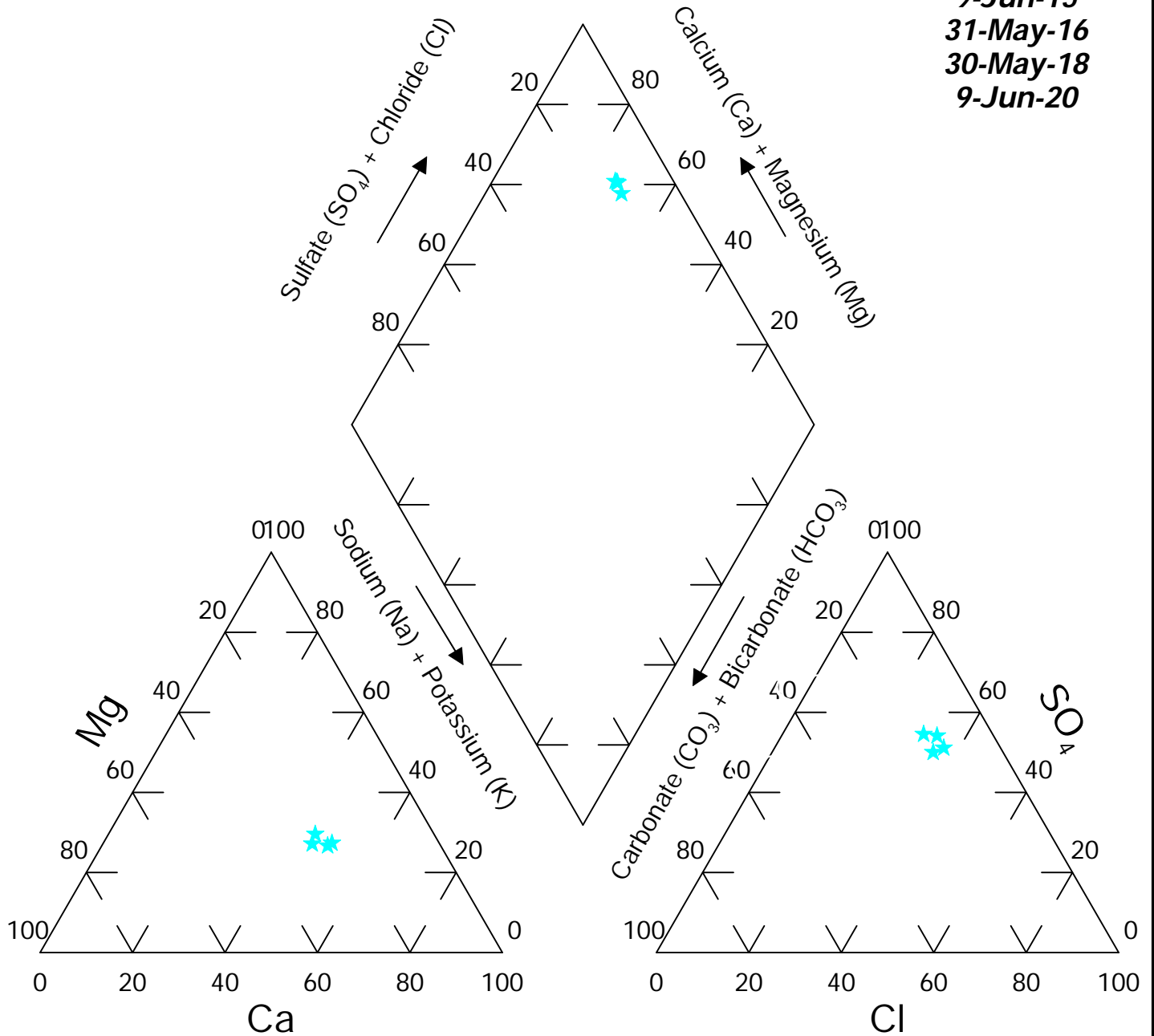

Site: Brady

Location : GWQ25-6N60-DR

Dates:
 9-Jun-15
 30-May-16
 24-May-17
 30-May-18
 21-May-19
 4-Jun-20

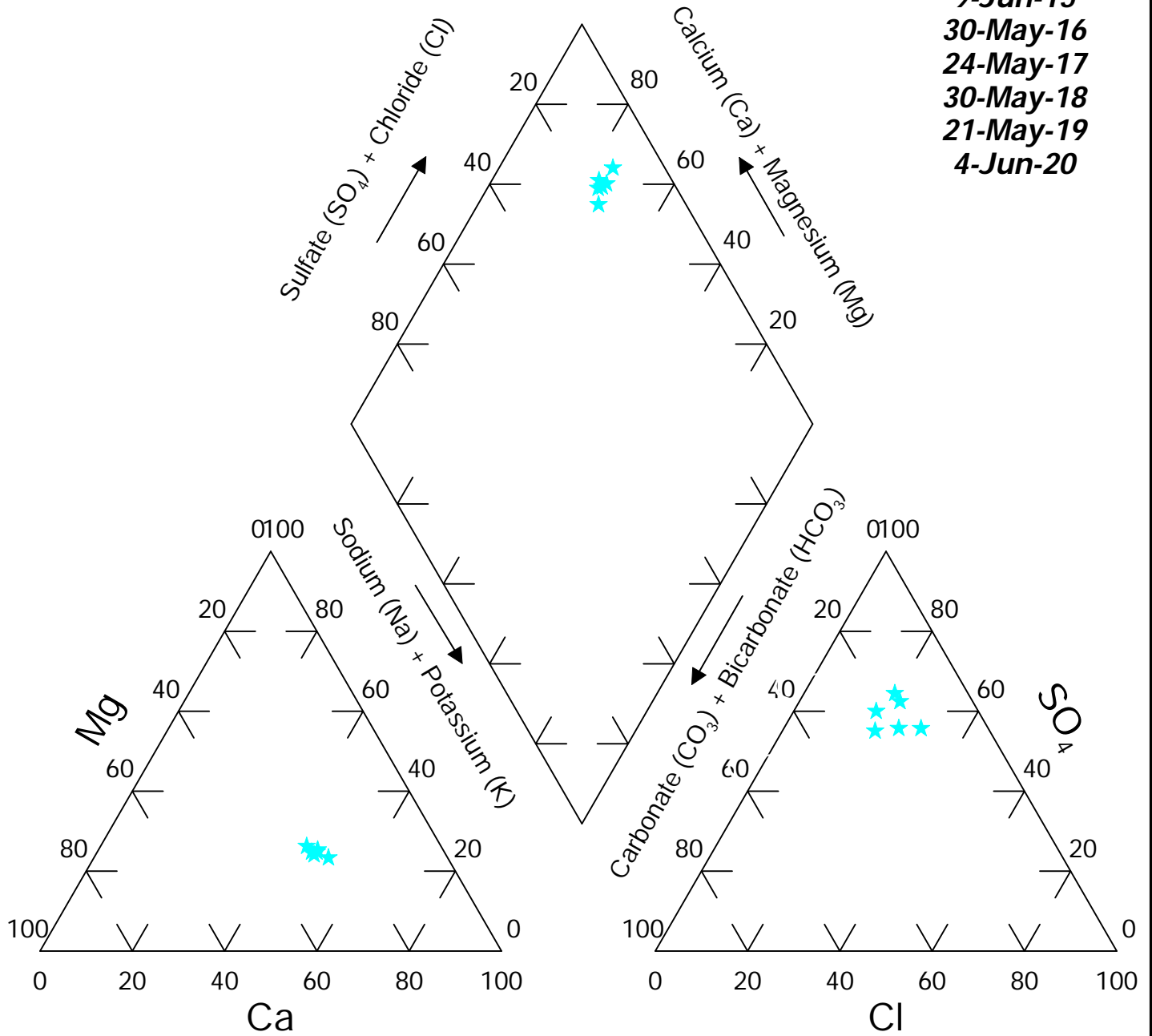

Site: Brady

Location : GWQ25-6N63-E

Dates:
 4-Jun-15
 26-May-16
 30-May-17
 31-May-18
 21-May-19
 8-Jun-20

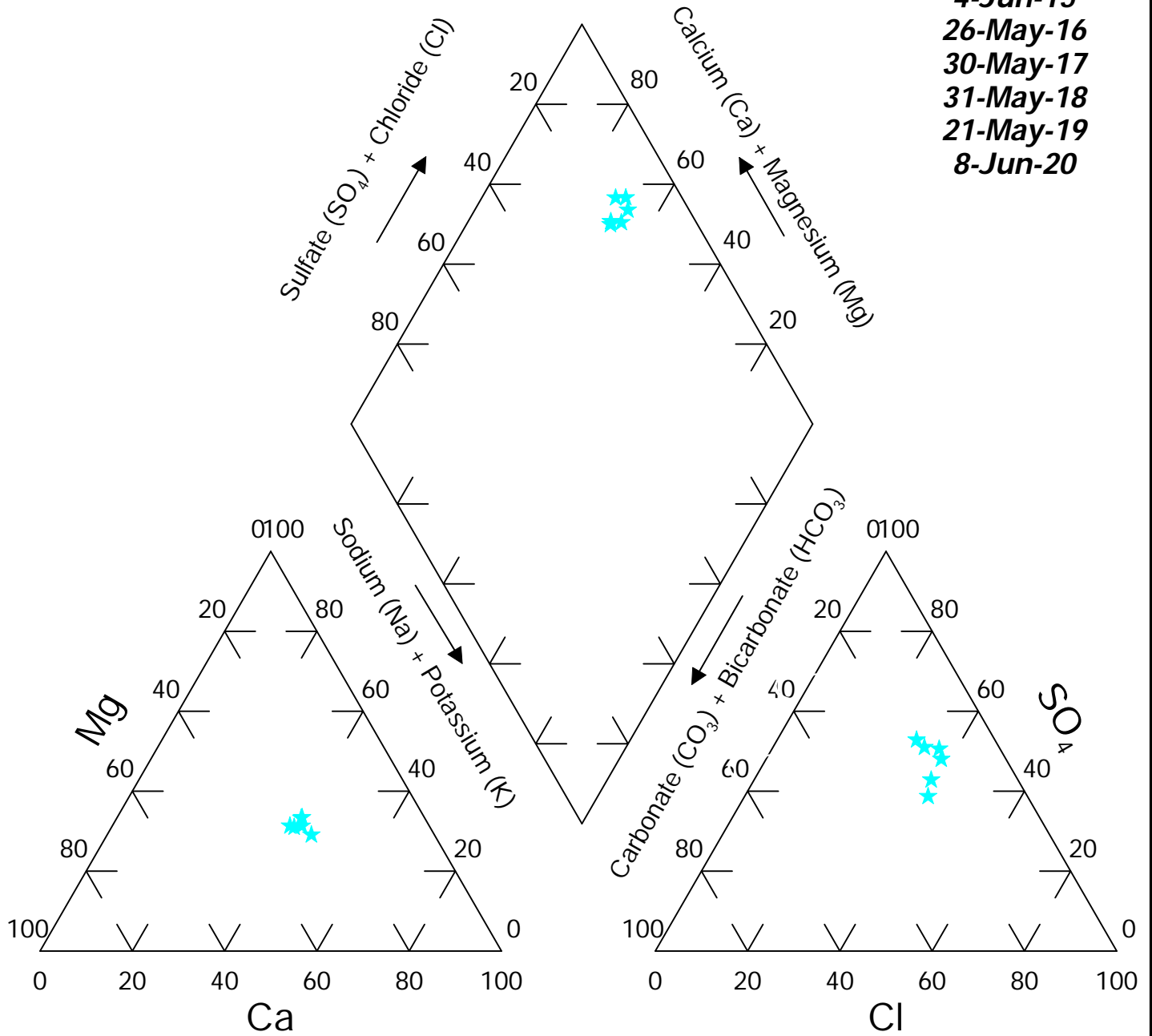

Site: Brady

Location : GWQ25-6N67-E

Dates:
 8-Jun-15
 26-May-16
 25-May-17
 30-May-18
 21-May-19
 9-Jun-20

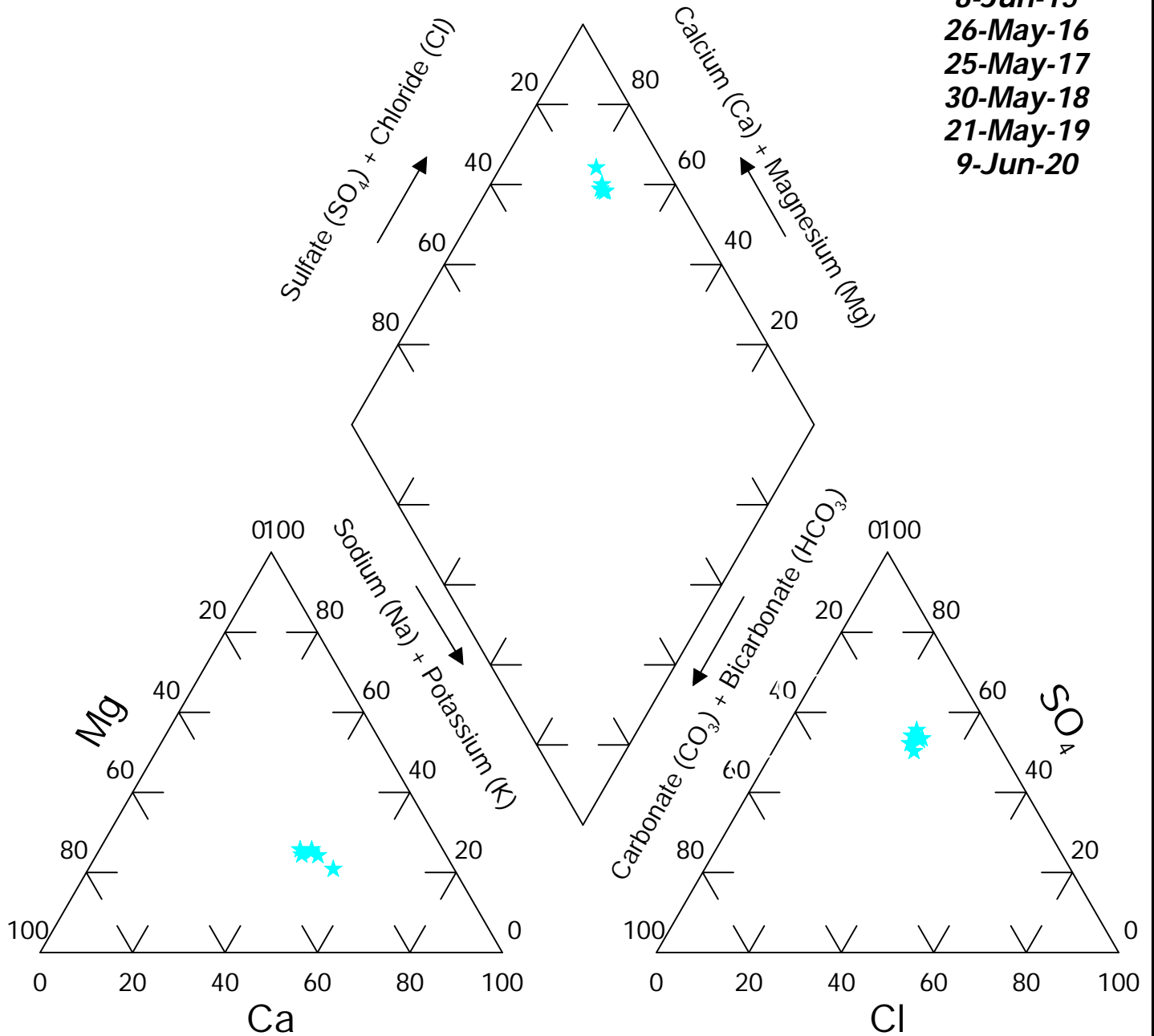

Site: Brady
Well #: 4N34-D/DR

Dates:
 8-Jun-15
 7-Jun-16
 25-May-17
 4-May-18
 16-May-19
 8-Jun-20

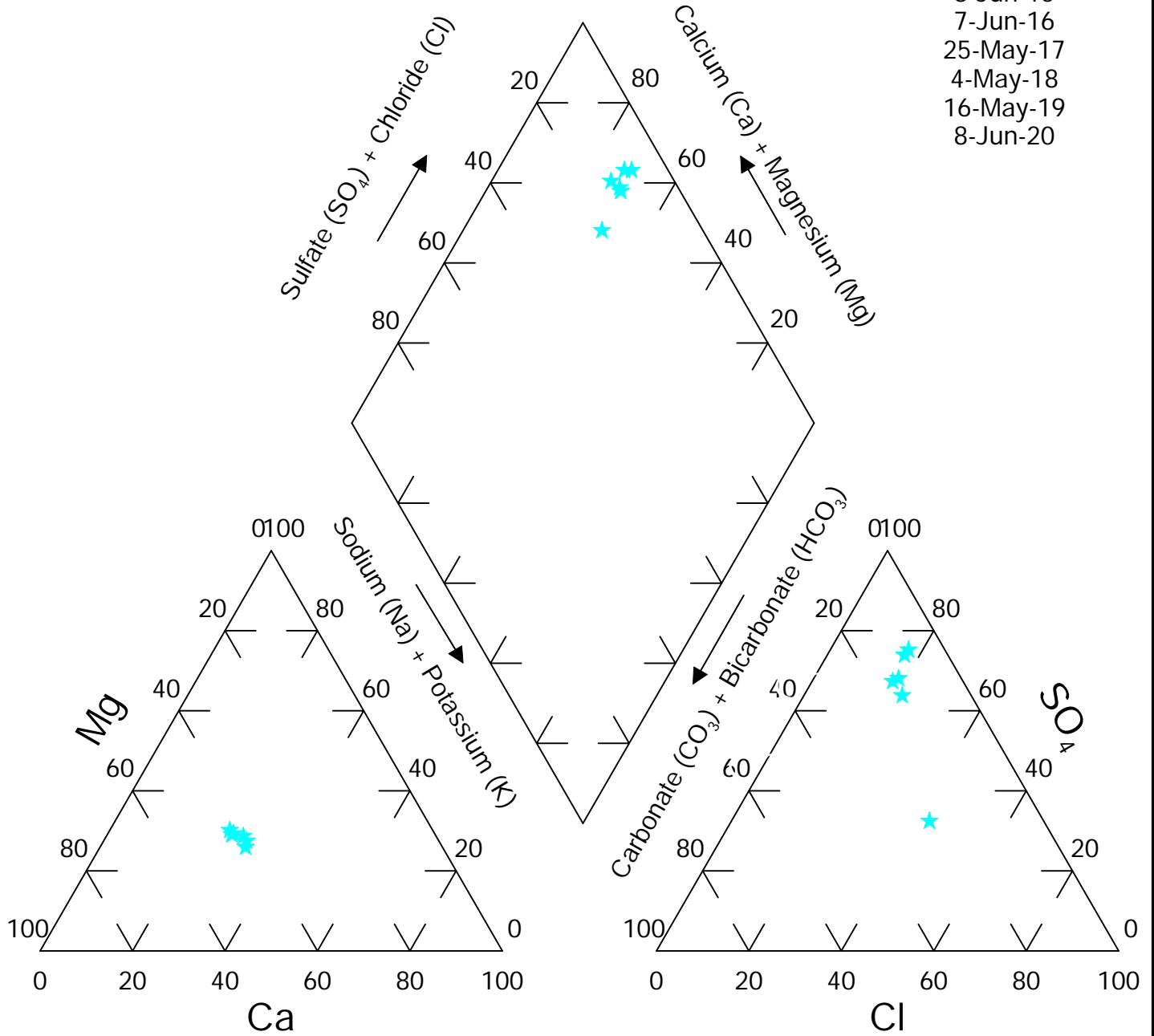

FIGURE: 10P

Site: Brady

Well #: 5N62-E

Dates:

- 4-Jun-15
- 15-Oct-15
- 30-May-16
- 27-Oct-16
- 29-May-17
- 17-Oct-17
- 31-May-18
- 15-Oct-18
- 22-May-19
- 3-Oct-19
- 4-Jun-20
- 13-Oct-20

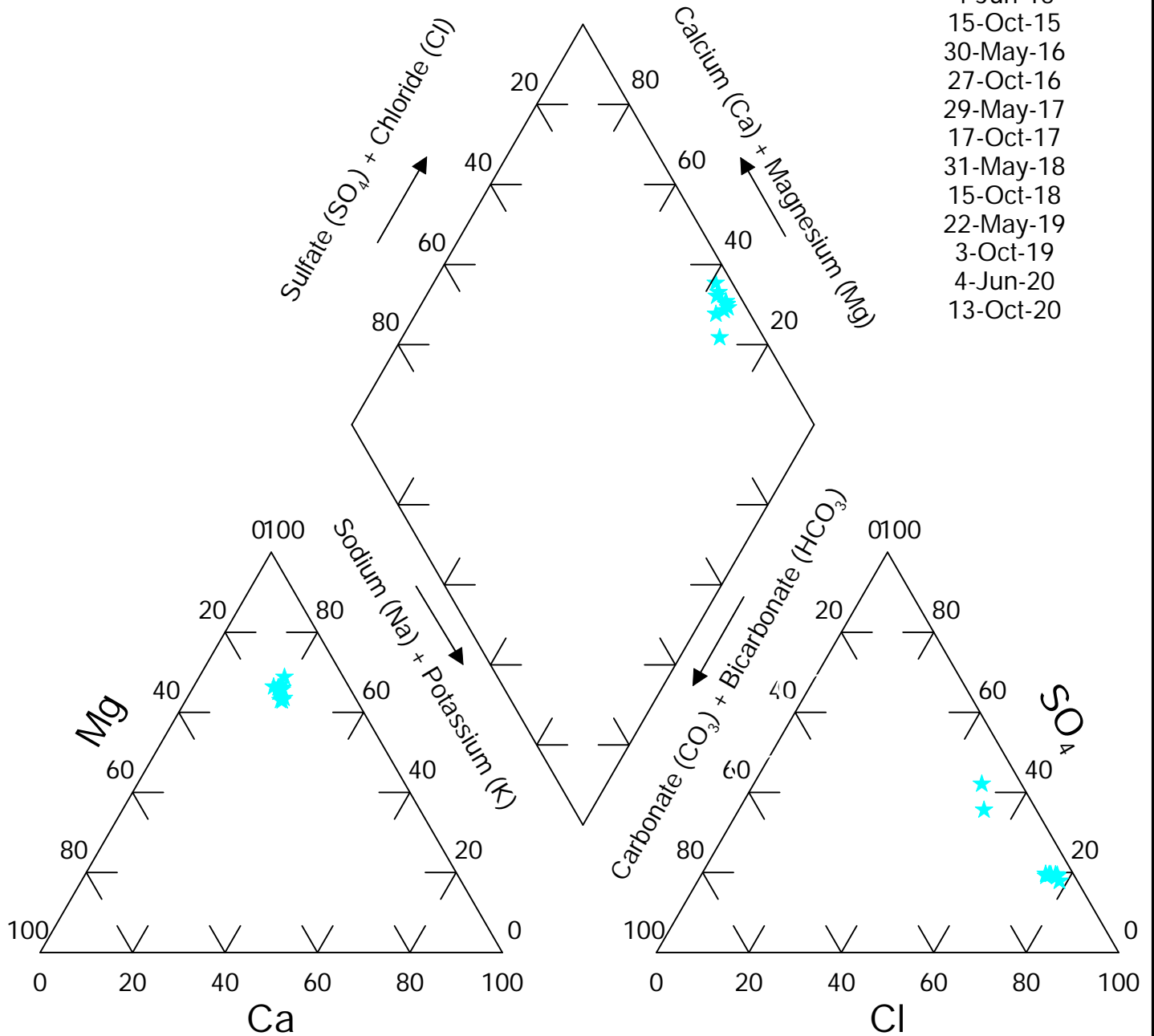

FIGURE: 11P

Site: Brady
Well #: 6N57-F/FR

Dates:
10-Jun-15
26-May-16
24-May-17
30-May-18
21-May-19
8-Jun-20

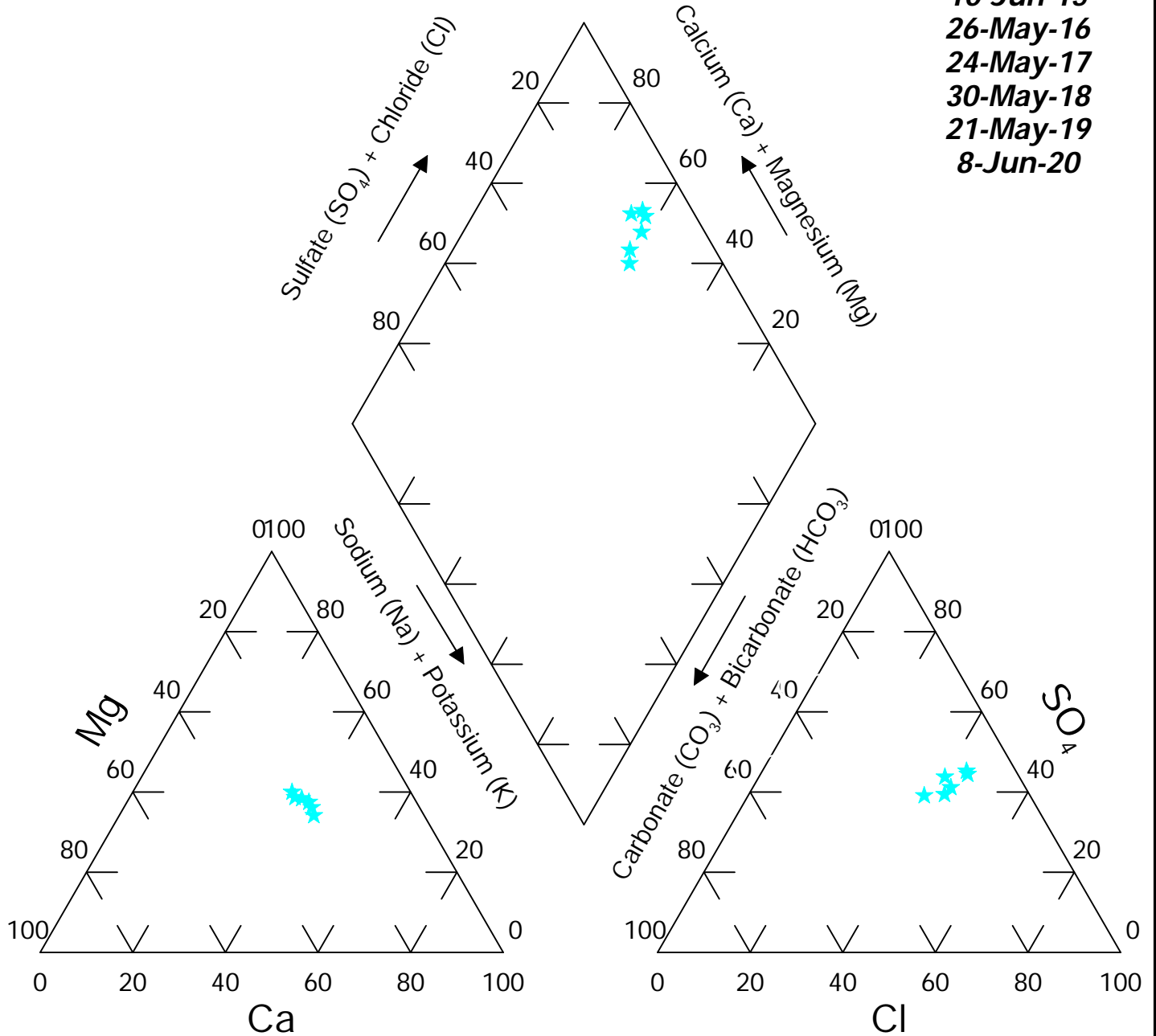
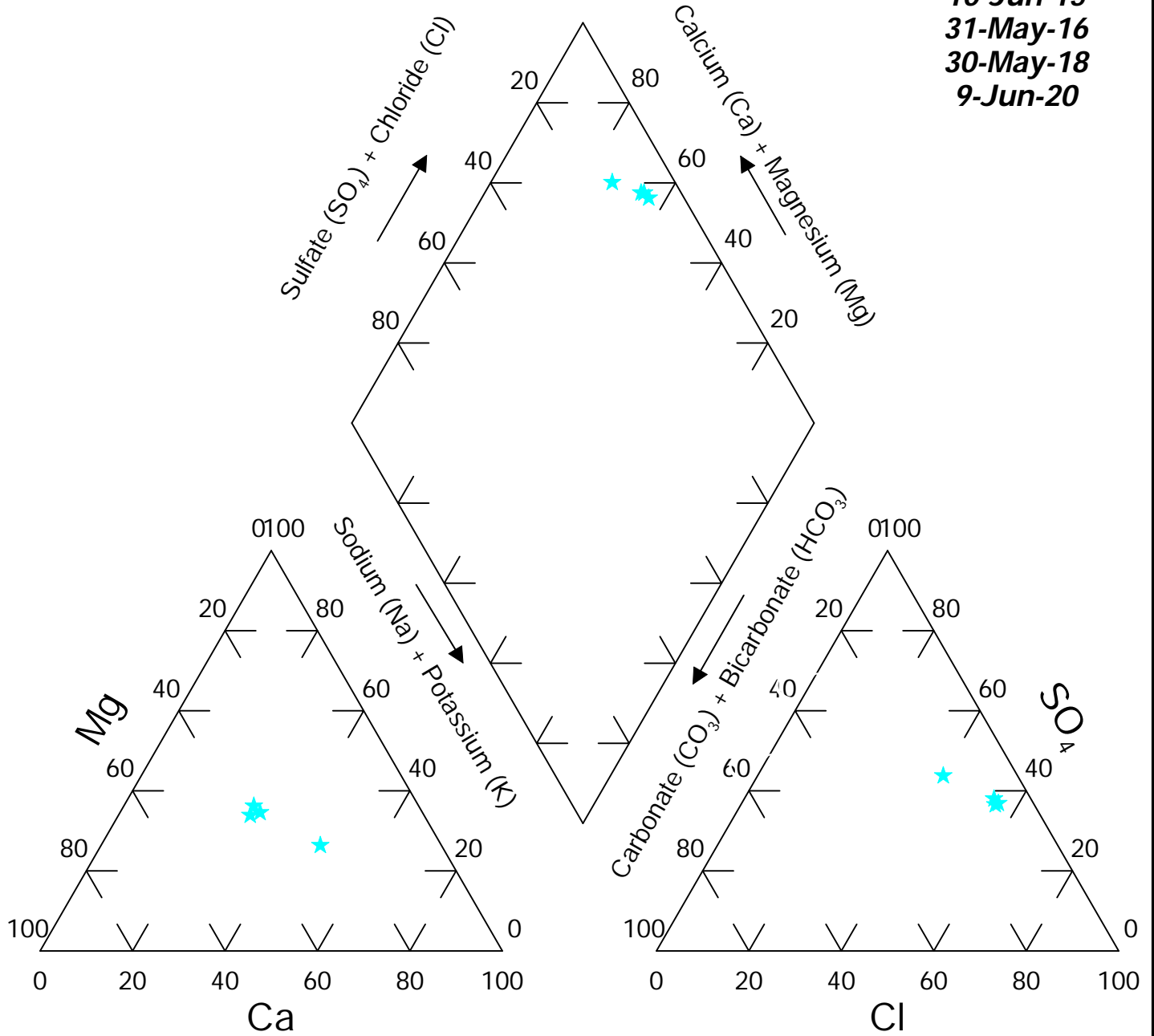

FIGURE: 12P

Site: Brady

Well #: 6N58FR

Dates:
 10-Jun-15
 31-May-16
 30-May-18
 9-Jun-20



Site: Brady
Well #: 6N59-F/FR

Dates:
11-Jun-15
30-May-16
30-May-18
9-Jun-20

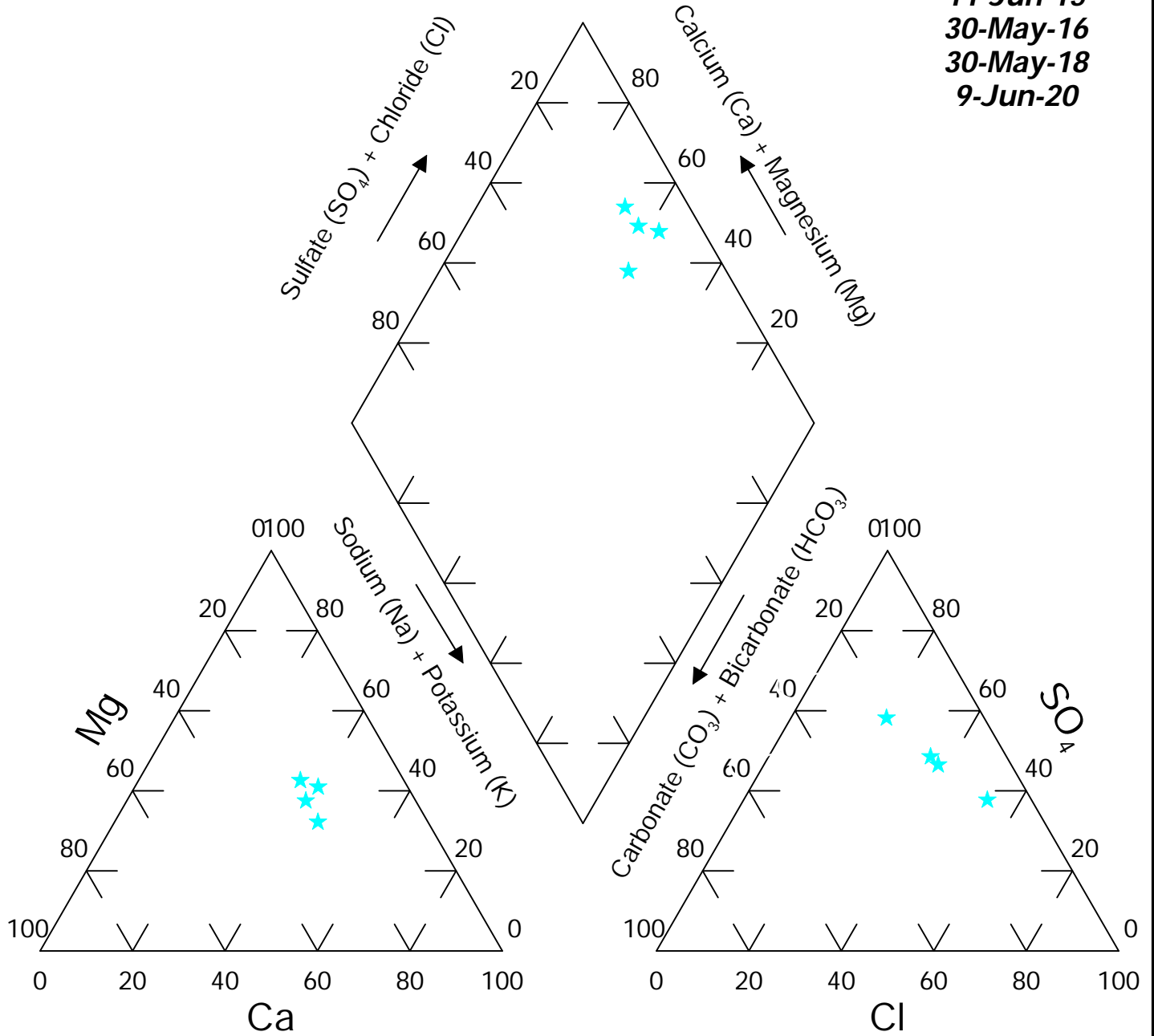

FIGURE: 14P

Site: Brady
Well #: 6N60-E/ER

Dates:
 8-Jun-15
 15-Oct-15
 30-May-16
 27-Oct-16
 24-May-17
 17-Oct-17
 30-May-18
 15-Oct-18
 21-May-19
 3-Oct-19
 4-Jun-20
 15-Oct-20

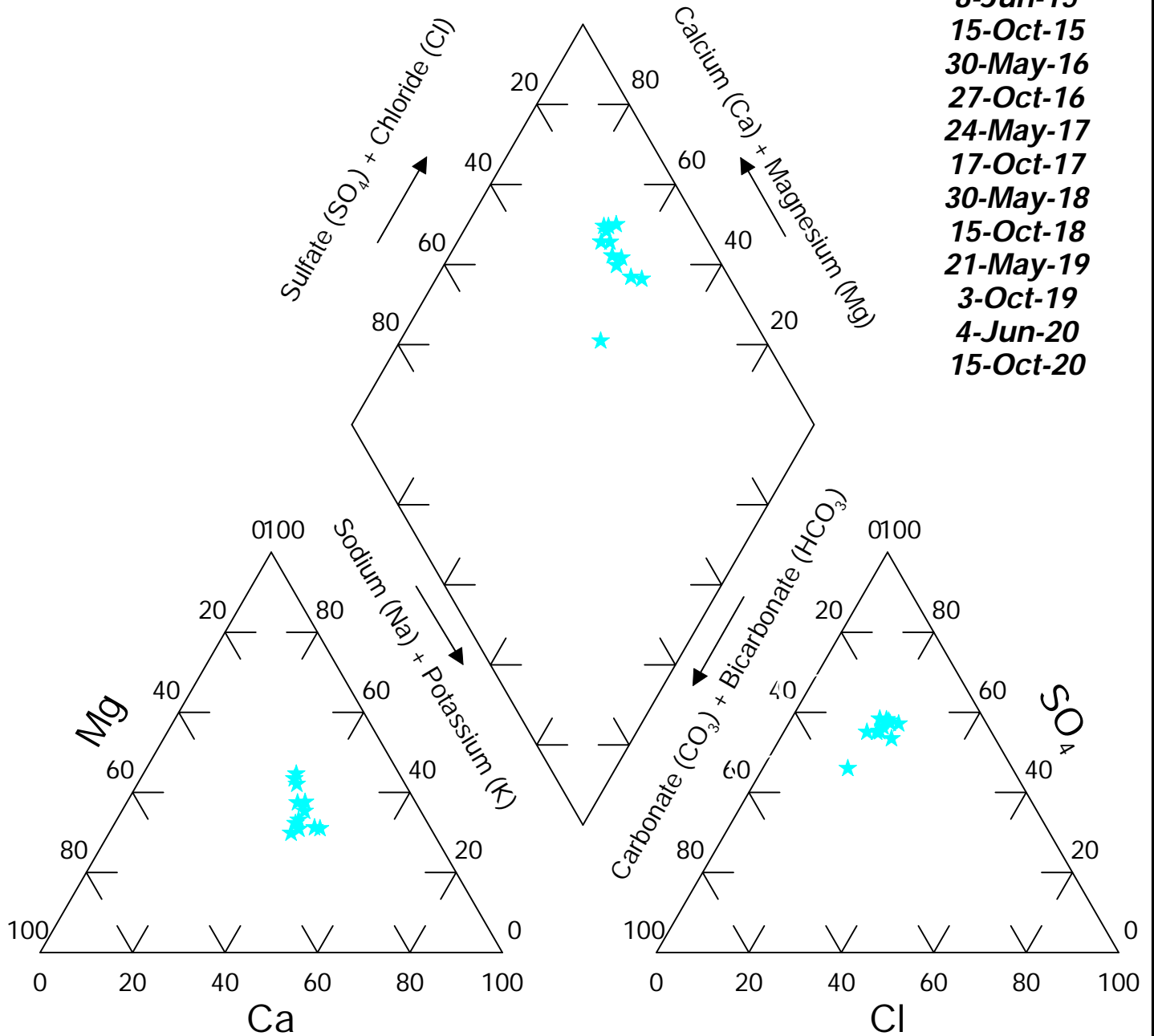

FIGURE: 15P

Site: Brady Well #: 6N63-F

Dates:
 4-Jun-15
 26-May-16
 29-May-17
 31-May-18
 21-May-19
 10-Jun-20

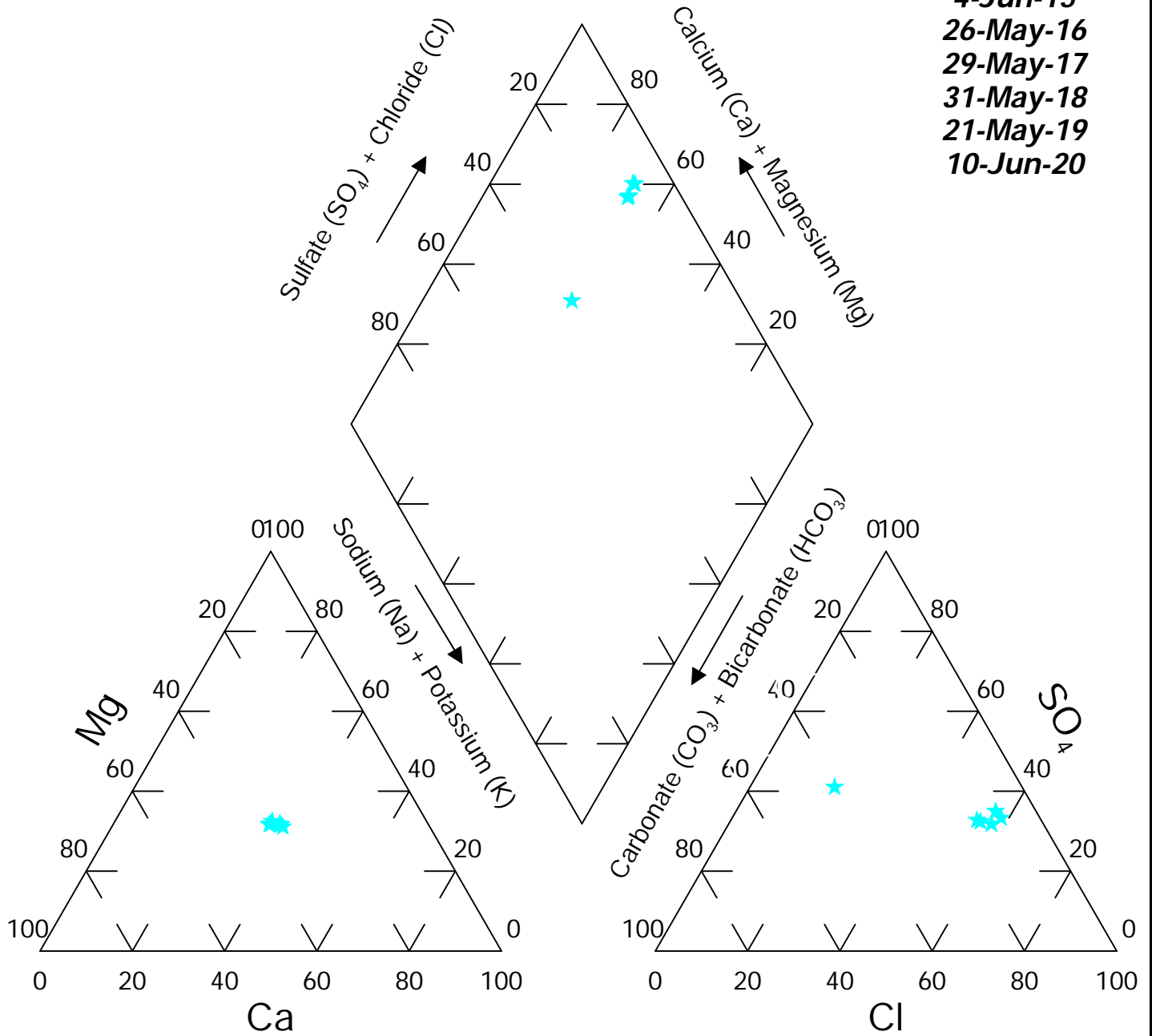

FIGURE: 16P

Site: Brady

Well #: 6N67-F

Dates:
 8-Jun-15
 26-May-16
 25-May-17
 30-May-18
 21-May-19
 9-Jun-20

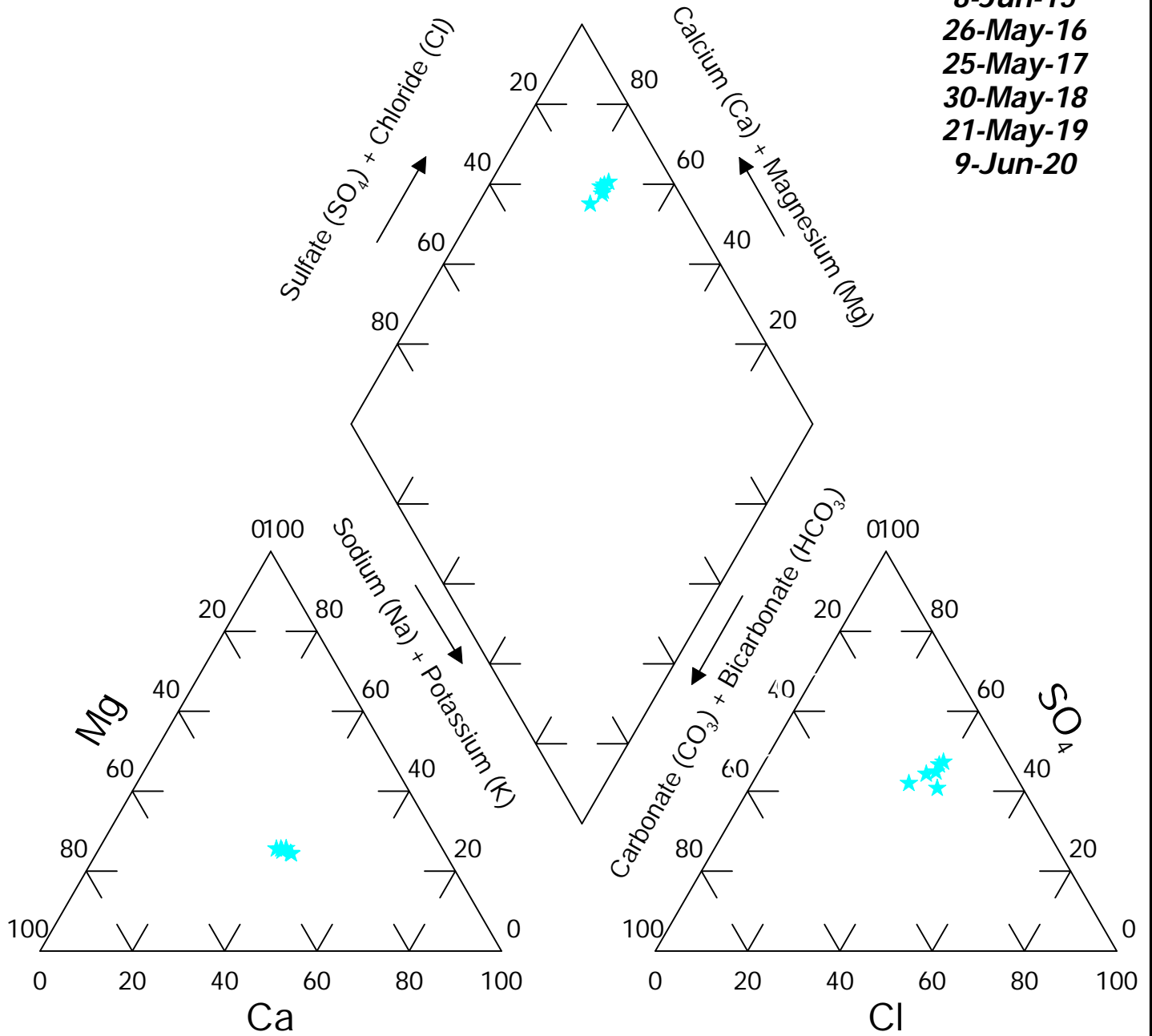
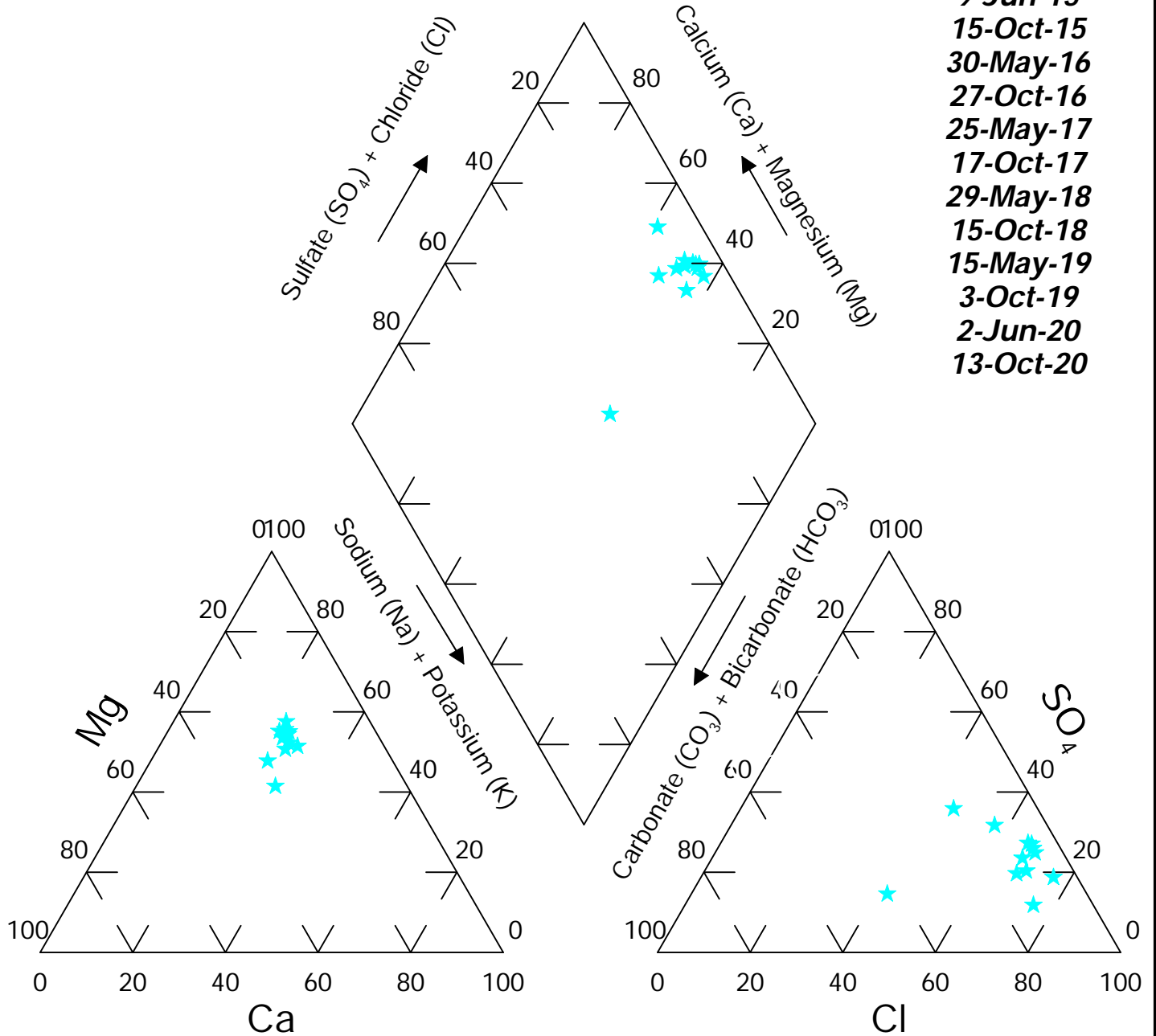

FIGURE: 17P

Site: Brady Well #: 13A

- Dates:**
 9-Jun-15
 15-Oct-15
 30-May-16
 27-Oct-16
 25-May-17
 17-Oct-17
 29-May-18
 15-Oct-18
 15-May-19
 3-Oct-19
 2-Jun-20
 13-Oct-20



Site: Brady Well #: 14A

Dates:
 4-Jun-15
 15-Oct-15
 30-May-16
 28-Oct-16
 25-May-17
 17-Oct-17
 29-May-18
 16-Oct-18
 15-May-19
 3-Oct-19
 3-Jun-20
 15-Oct-20

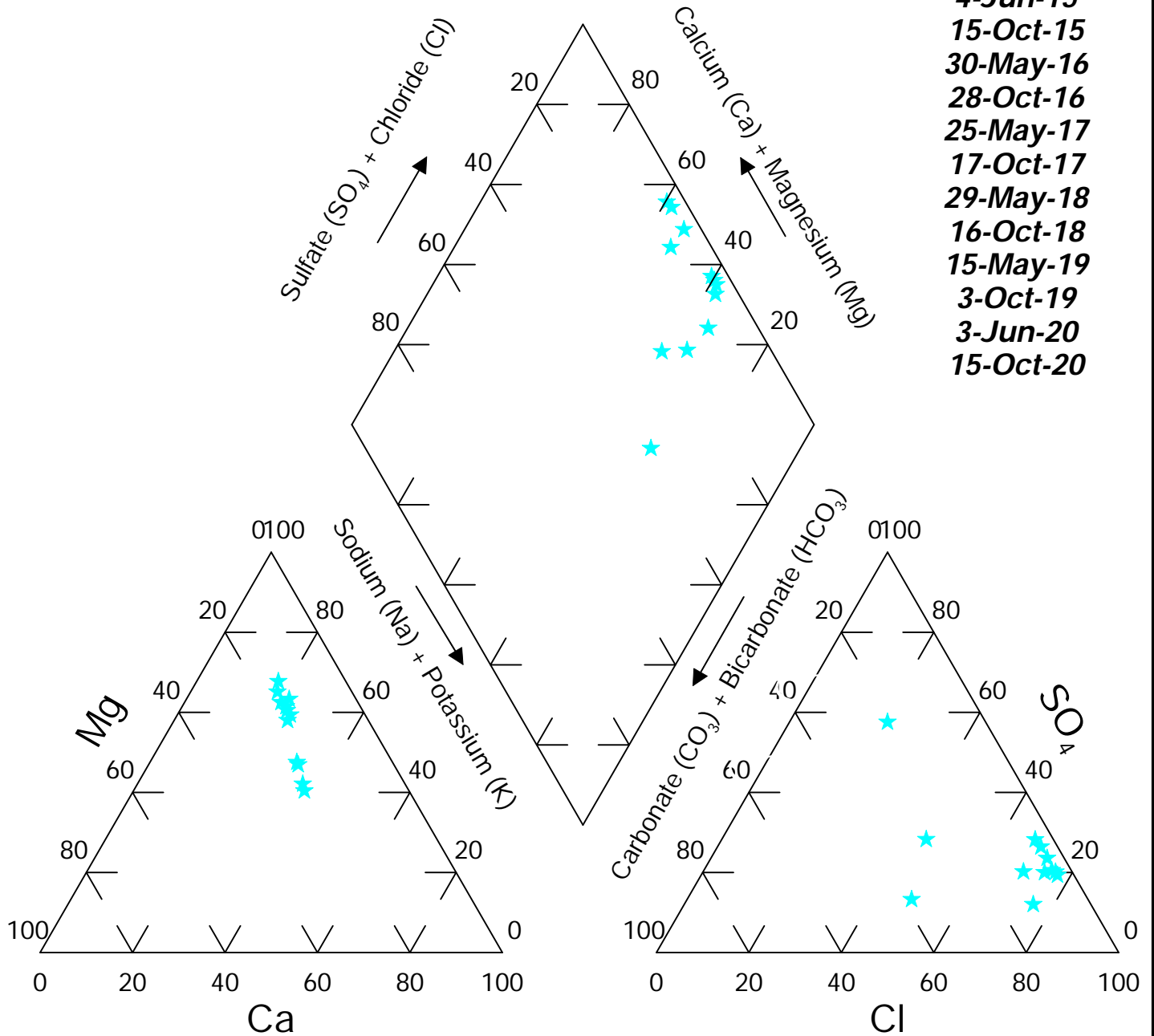
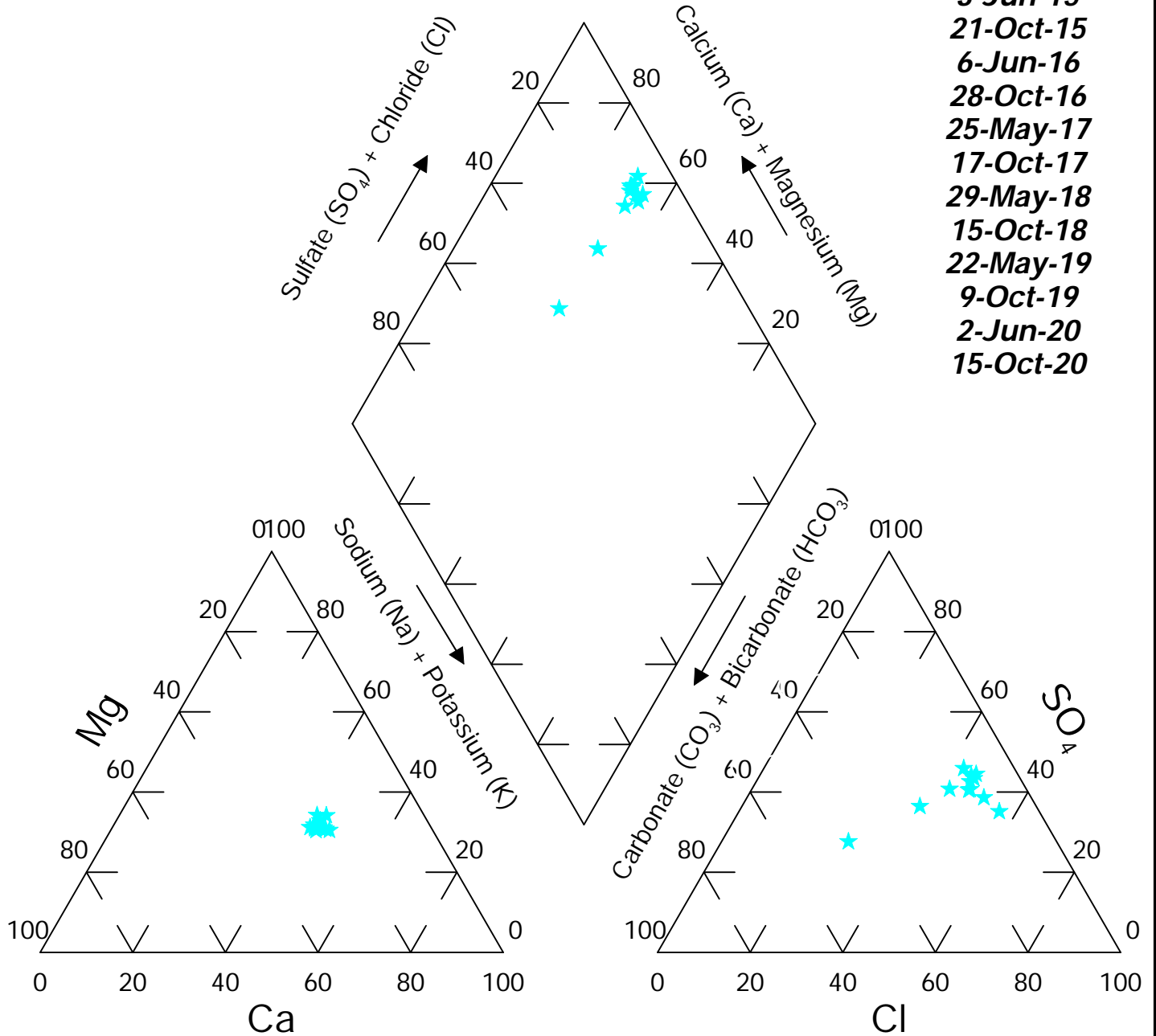

FIGURE: 13P

Site: Brady Well #: 15A

Dates:
 3-Jun-15
 21-Oct-15
 6-Jun-16
 28-Oct-16
 25-May-17
 17-Oct-17
 29-May-18
 15-Oct-18
 22-May-19
 9-Oct-19
 2-Jun-20
 15-Oct-20



Site: Brady Well #: 16A

- Dates:**
 9-Jun-15
 15-Oct-15
 6-Jun-16
 28-Oct-16
 25-May-17
 18-Oct-17
 29-May-18
 15-Oct-18
 22-May-19
 9-Oct-19
 2-Jun-20
 15-Oct-20

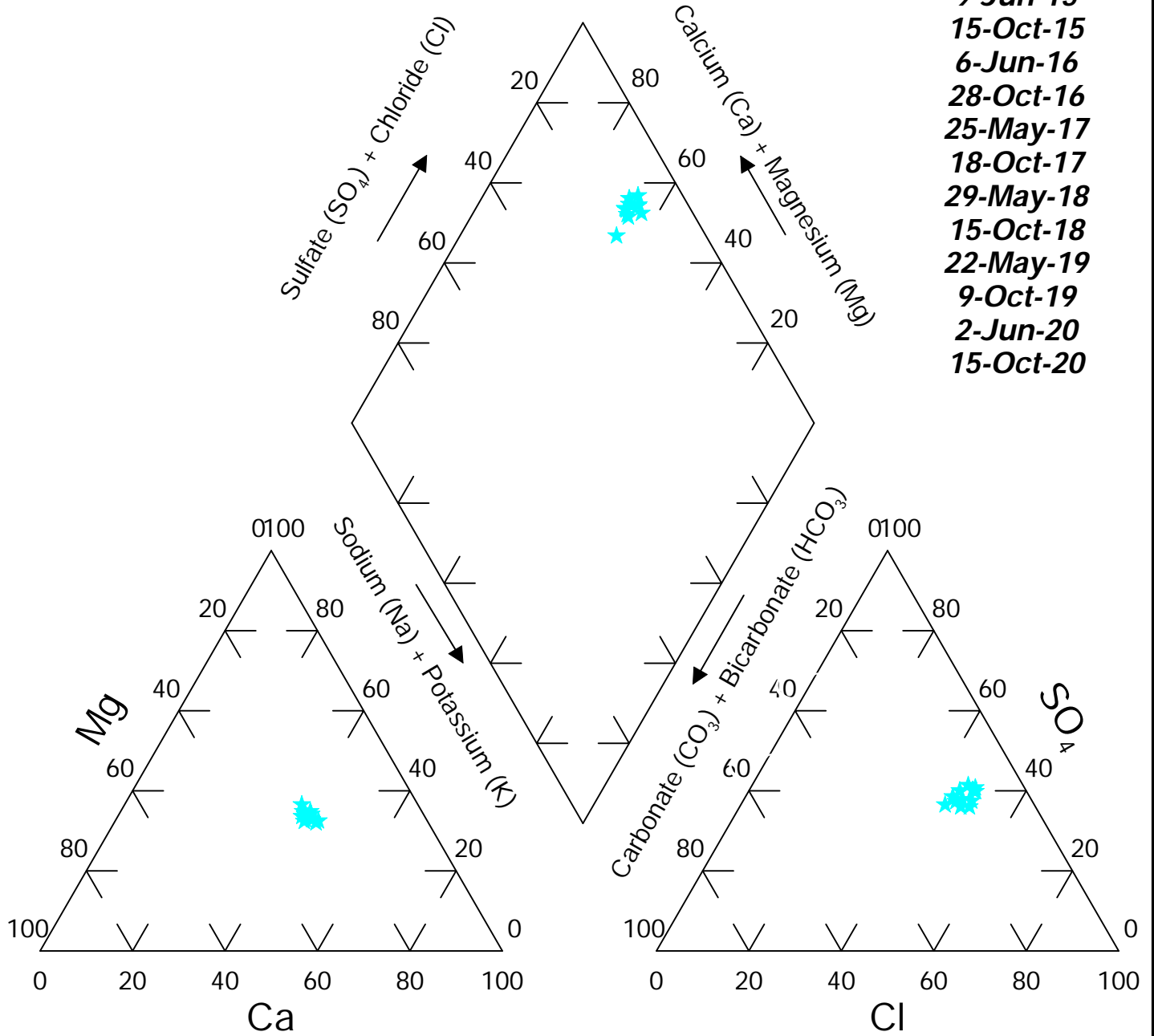

Site: Brady Well #: W4

Dates:

- 2-Jun-15
- 26-Oct-15
- 24-May-16
- 26-Oct-16
- 23-May-17
- 19-Oct-17
- 24-May-18
- 16-Oct-18
- 9-May-19
- 7-Oct-19
- 28-May-20
- 20-Oct-20

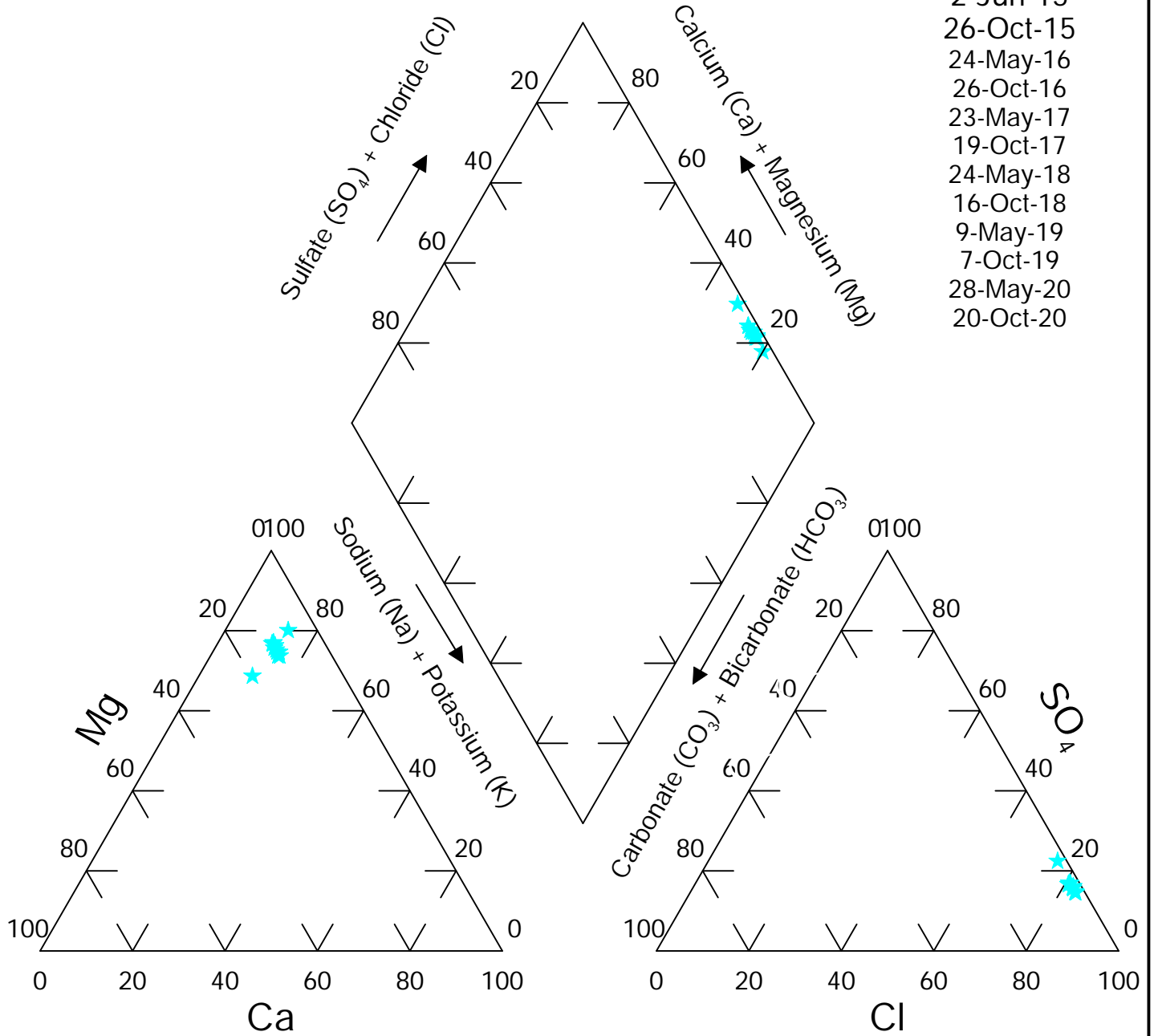

FIGURE: 1P

Site: Brady Well #: W5

Dates:
 2-Jun-15
 26-Oct-15
 24-May-16
 26-Oct-16
 23-May-17
 19-Oct-17
 24-May-18
 18-Oct-18
 9-May-19
 7-Oct-19
 28-May-20
 15-Oct-20

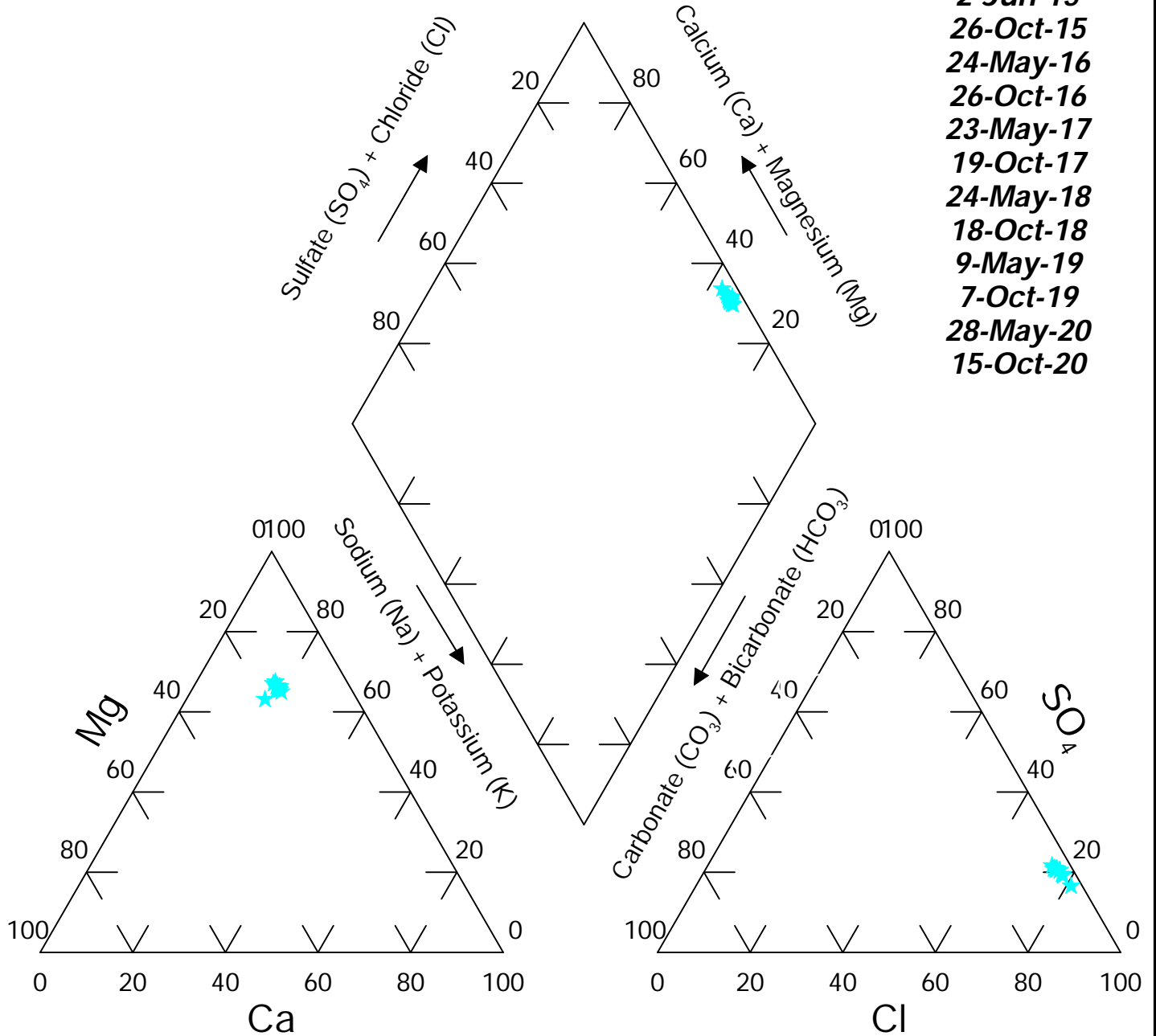

FIGURE: 2P

Site: Brady Well #: W6

- Dates:**
- 3-Jun-15
 - 26-Oct-15
 - 30-May-16
 - 25-Oct-16
 - 24-May-17
 - 17-Oct-17
 - 23-May-18
 - 18-Oct-18
 - 14-May-19
 - 13-Nov-19
 - 4-Jun-20
 - 15-Oct-20

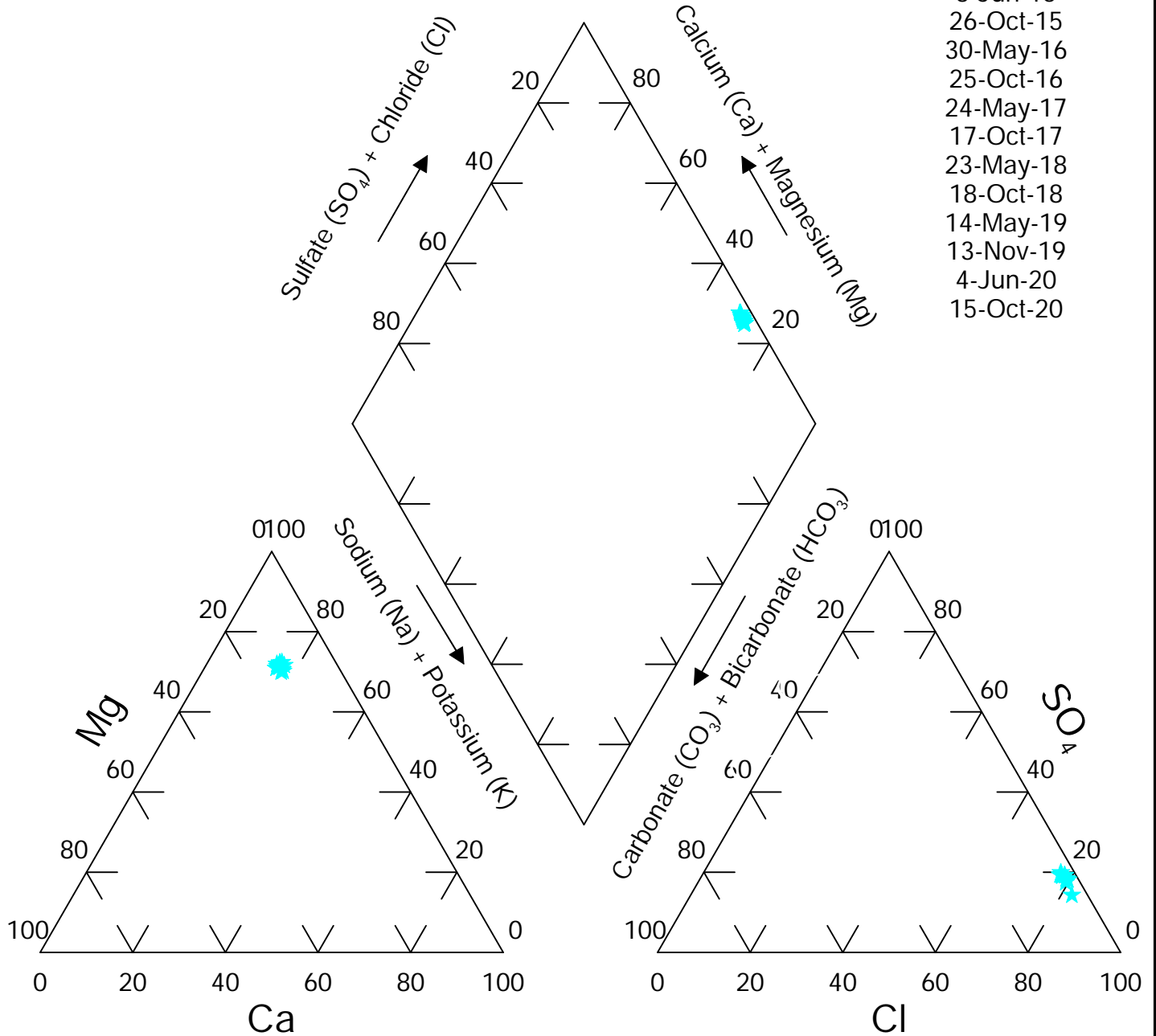

FIGURE: 3P

Site: Brady Well #: W7

Dates:
 2-Jun-15
 26-Oct-15
 24-May-16
 24-Oct-16
 24-May-17
 17-Oct-17
 23-May-18
 17-Oct-18
 14-May-19
 13-Nov-19
 4-Jun-20
 20-Oct-20

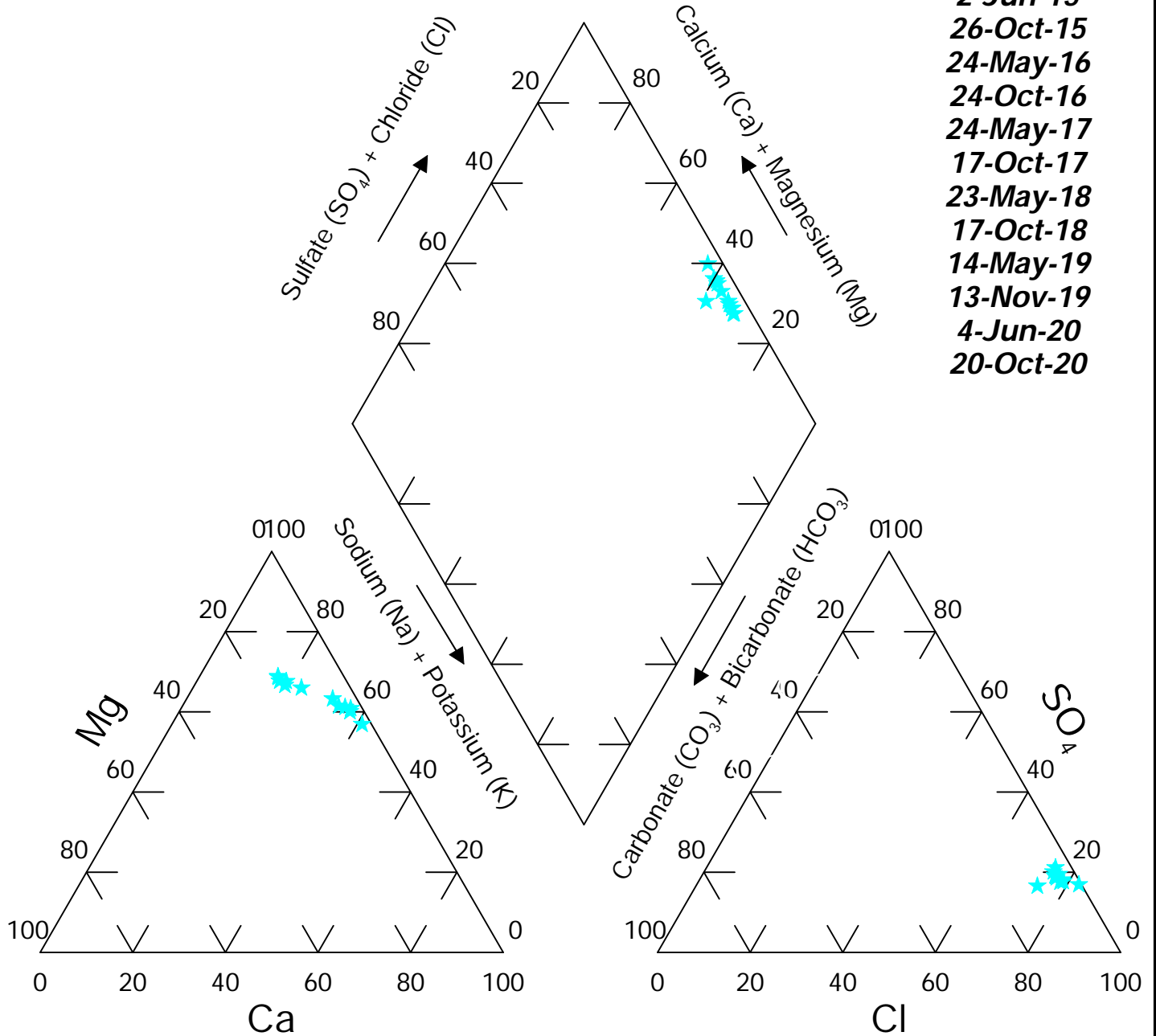

FIGURE: 4P

Site: Brady Well #: W8

Dates:
 3-Jun-15
 26-Oct-15
 25-May-16
 24-Oct-16
 24-May-17
 17-Oct-17
 29-May-18
 18-Oct-18
 13-May-19
 13-Nov-19
 4-Jun-20
 20-Oct-20

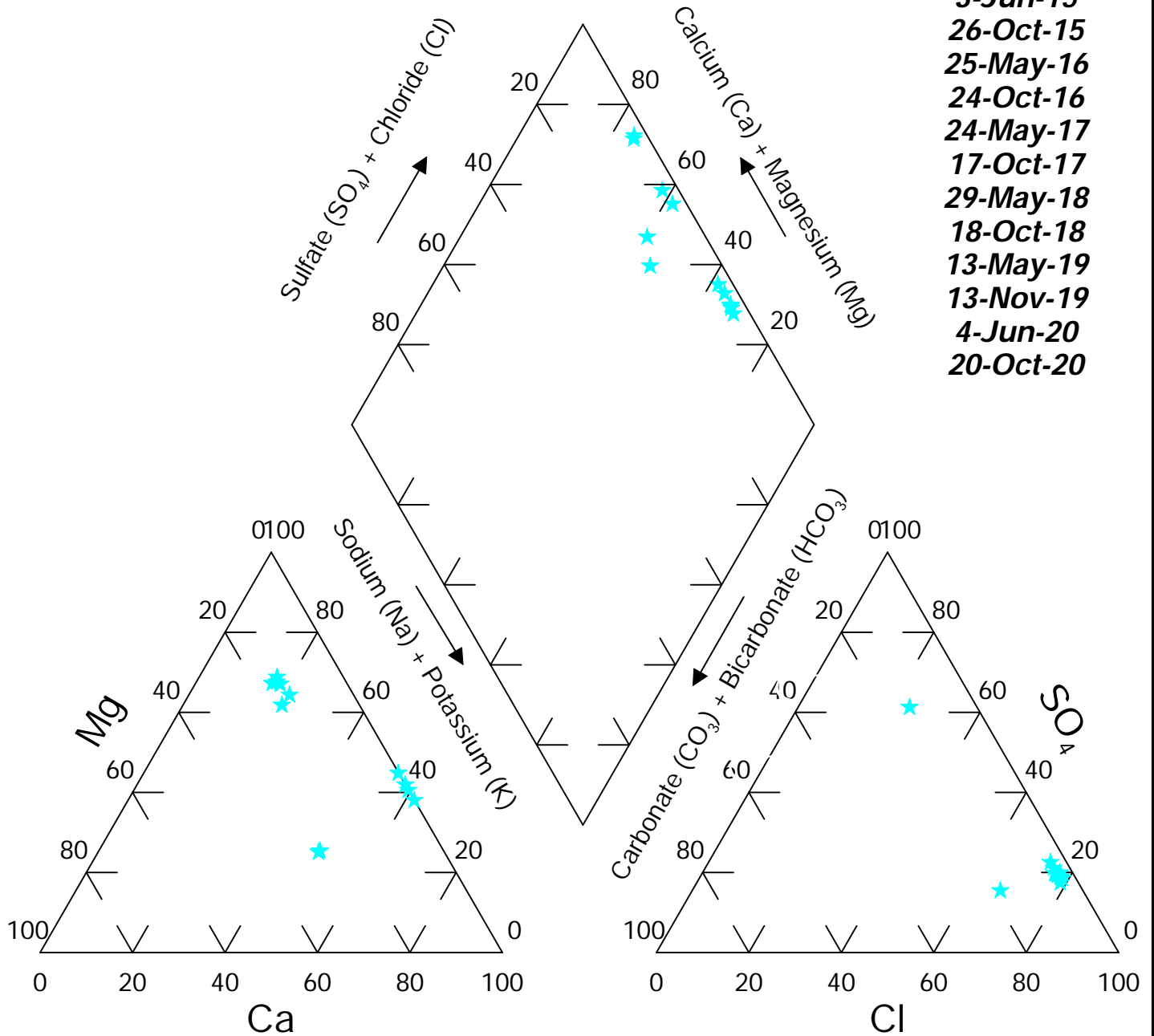

FIGURE: 5P

Site: Brady Well #: W9

Dates:
 3-Jun-15
 22-Oct-15
 24-May-16
 26-Oct-16
 23-May-17
 18-Oct-17
 24-May-18
 18-Oct-18
 15-May-19
 8-Oct-19
 4-Jun-20
 20-Oct-20

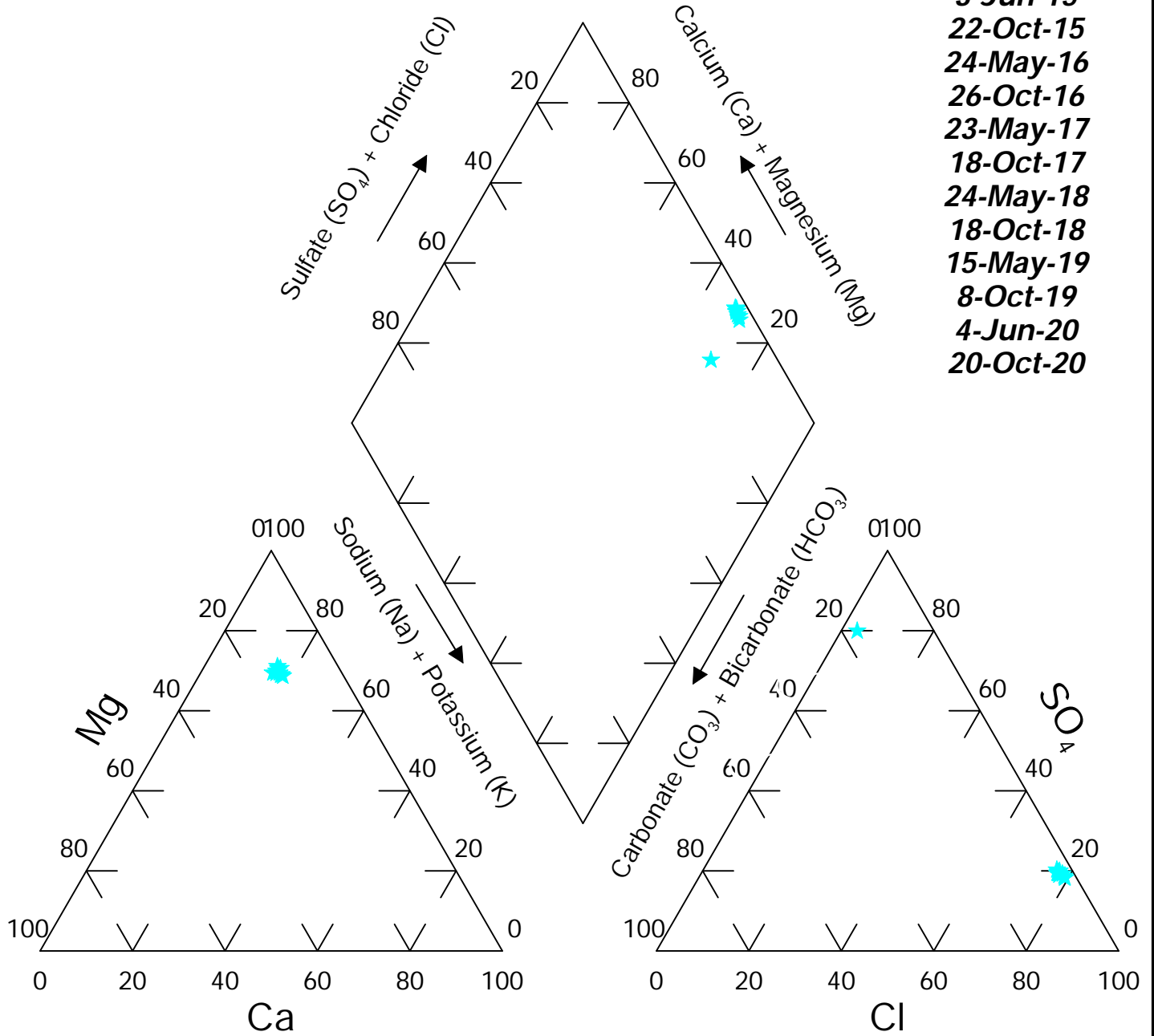

FIGURE: 6P

Site: Brady

Well #: W10/W10R

Dates:

- 3-Jun-15
- 22-Oct-15
- 25-May-16
- 26-Oct-16
- 23-May-17
- 18-Oct-17
- 24-May-18
- 16-Oct-18
- 15-May-19
- 8-Oct-19
- 27-May-20
- 23-Jul-20
- 14-Oct-20

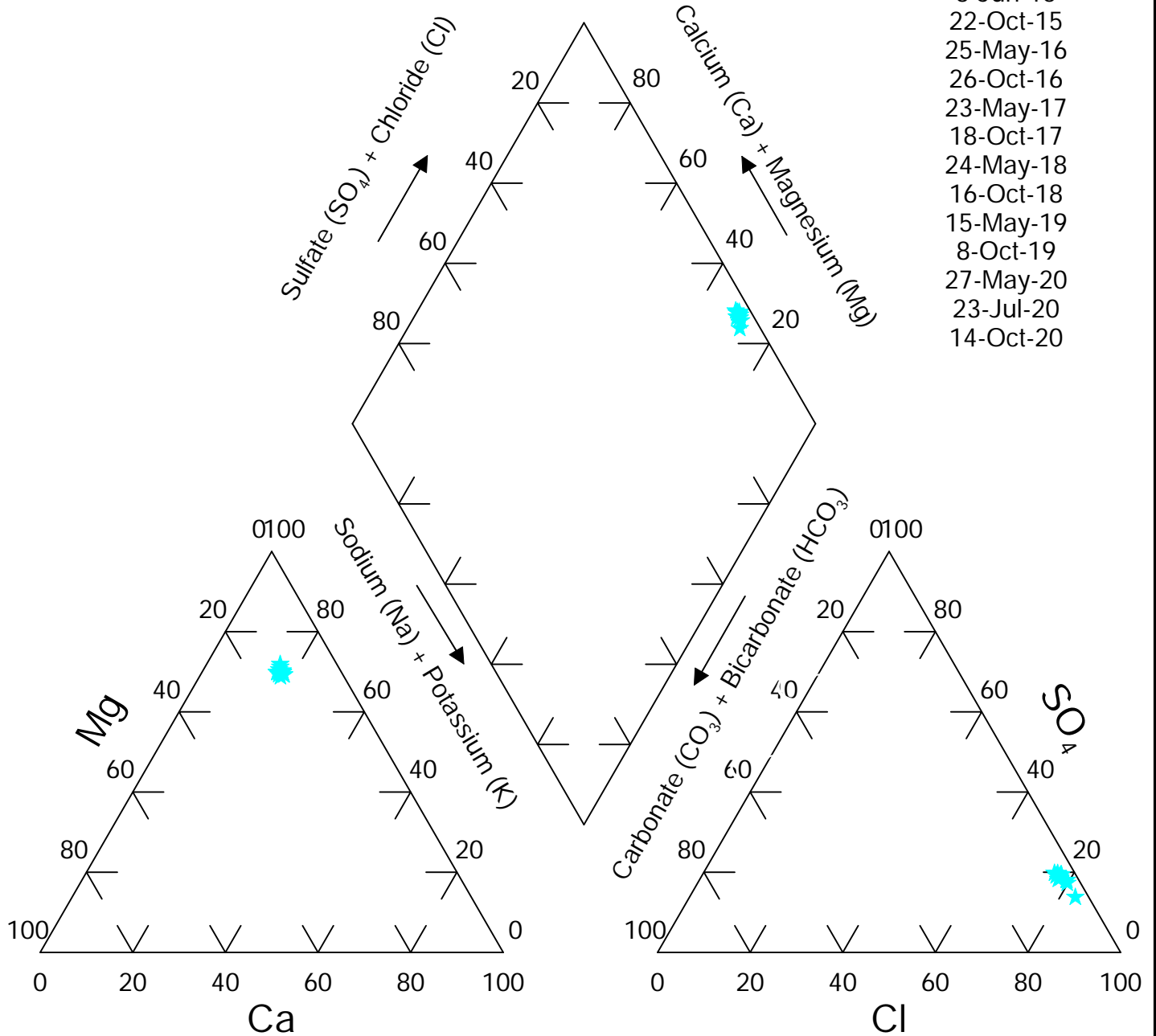

FIGURE: 7P

Site: Brady Well #: W11

Dates:

- 10-Jun-14
- 23-Oct-14
- 2-Jun-15
- 22-Oct-15
- 25-May-16
- 26-Oct-16
- 23-May-17
- 18-Oct-17
- 24-May-18
- 17-Oct-18
- 15-May-19
- 8-Oct-19

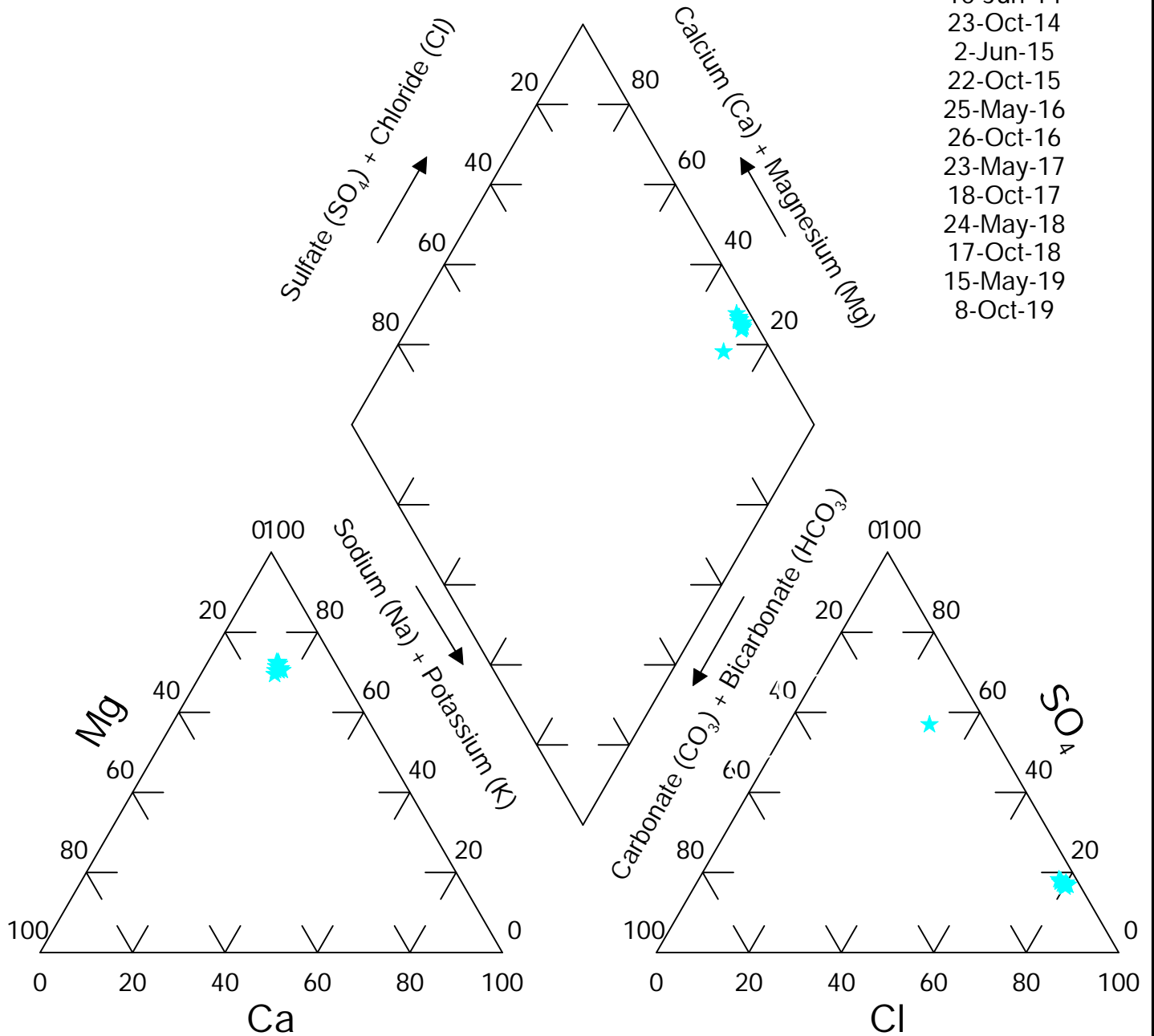

FIGURE: 8P

Site: Brady Well #: W12

- Dates:**
- 3-Jun-15
 - 22-Oct-15
 - 25-May-16
 - 26-Oct-16
 - 25-May-17
 - 17-Oct-17
 - 24-May-18
 - 17-Oct-18
 - 15-May-19
 - 14-Oct-19
 - 24-May-20
 - 14-Oct-20

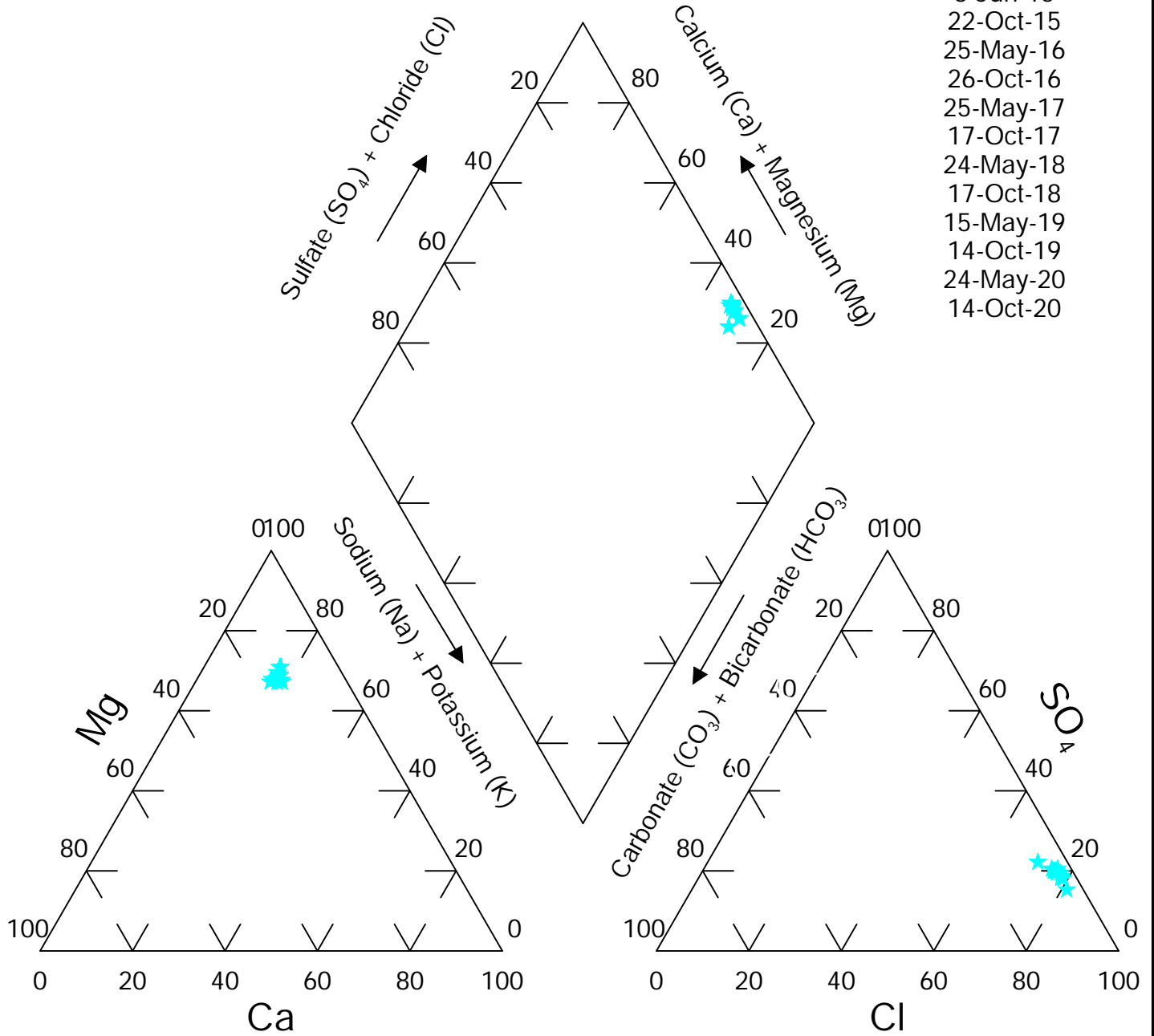

FIGURE: 9P

Site: Brady Location : W13

Dates:
 1-Jun-15
 21-Oct-15
 27-May-16
 24-Oct-16
 24-May-17
 16-Oct-17
 28-May-18
 17-Oct-18
 13-May-19
 8-Oct-19
 2-Jun-20
 20-Oct-20

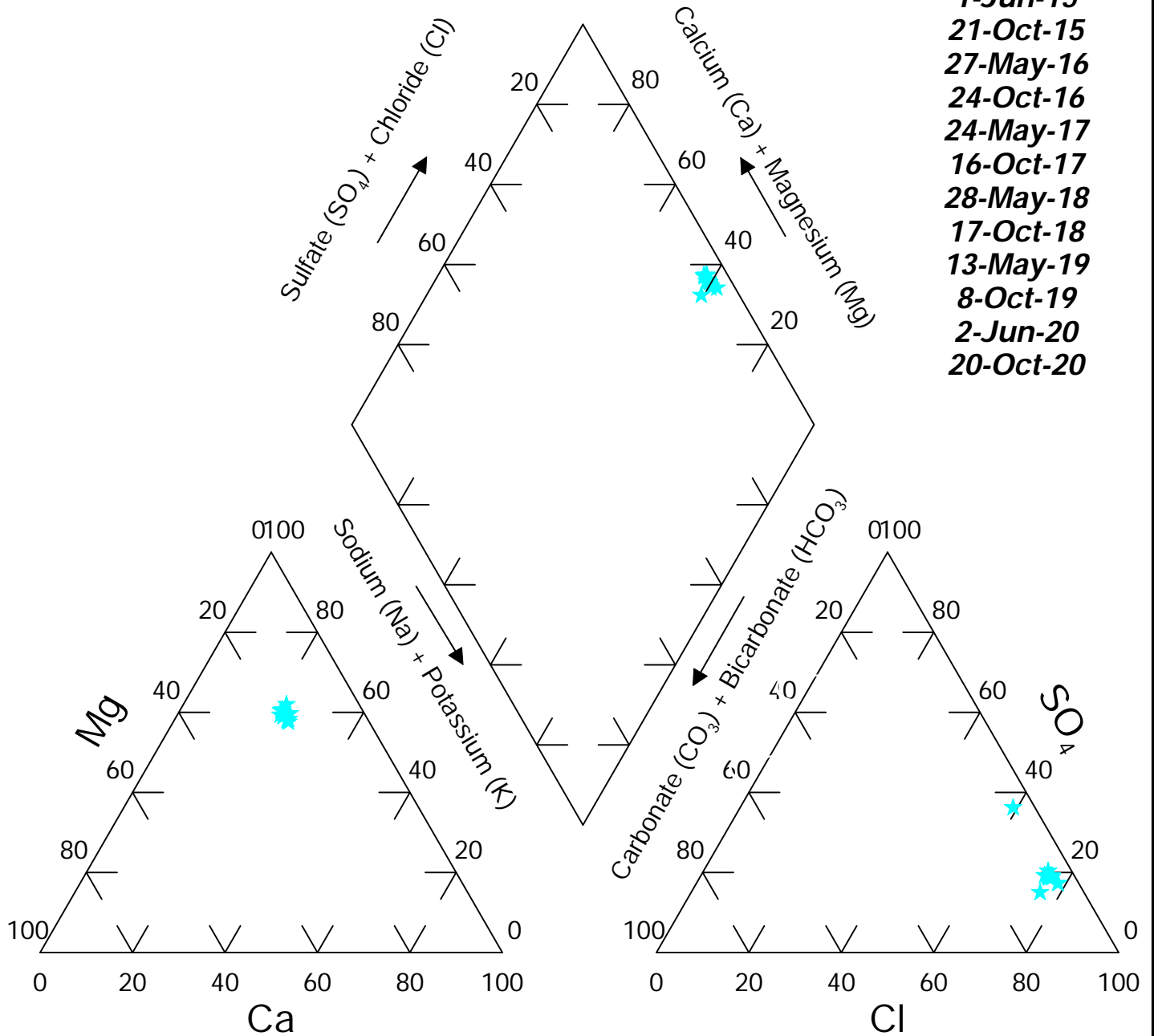

FIGURE: 1z

Site: Brady Location : GWQ25-W14

Dates:
 3-Jun-15
 21-Oct-15
 25-May-16
 26-Oct-16
 25-May-17
 16-Oct-17
 28-May-18
 18-Oct-18
 15-May-19
 13-Nov-19
 3-Jun-20
 15-Oct-20

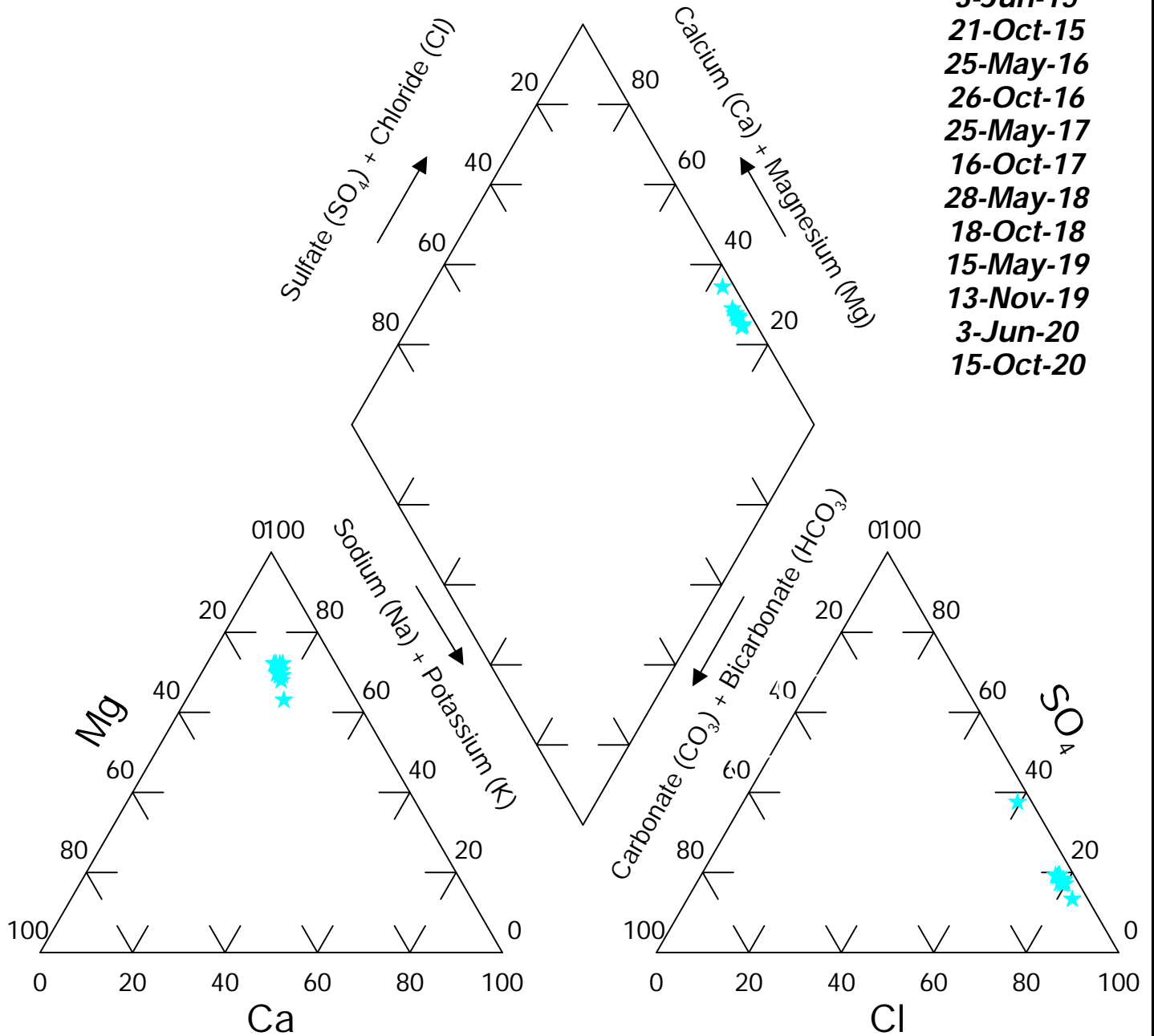

FIGURE: 2z

Site: Brady

Location : GWQ25-W15

Dates:
 3-Jun-15
 21-Oct-15
 30-May-16
 25-Oct-16
 25-May-17
 16-Oct-17
 28-May-18
 22-Oct-18
 15-May-19
 13-Oct-19
 2-Jun-20
 20-Oct-20

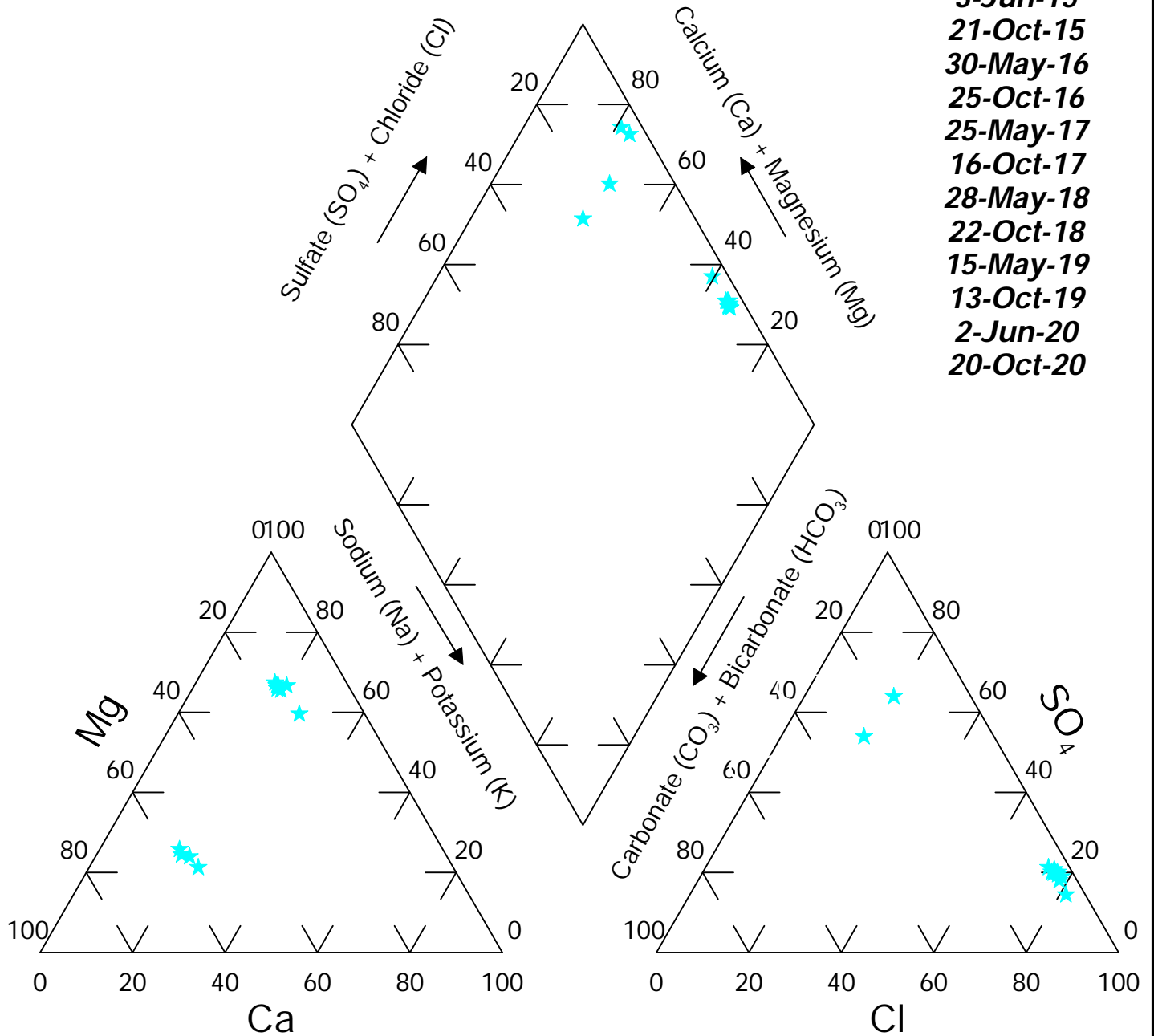

FIGURE: 3z

Site: Brady Location : GWQ25-W16

- Dates:**
 4-Jun-15
 21-Oct-15
 30-May-16
 25-Oct-16
 25-May-17
 16-Oct-17
 28-May-18
 22-Oct-18
 15-May-19
 8-Dec-19
 2-Jun-20
 21-Oct-20

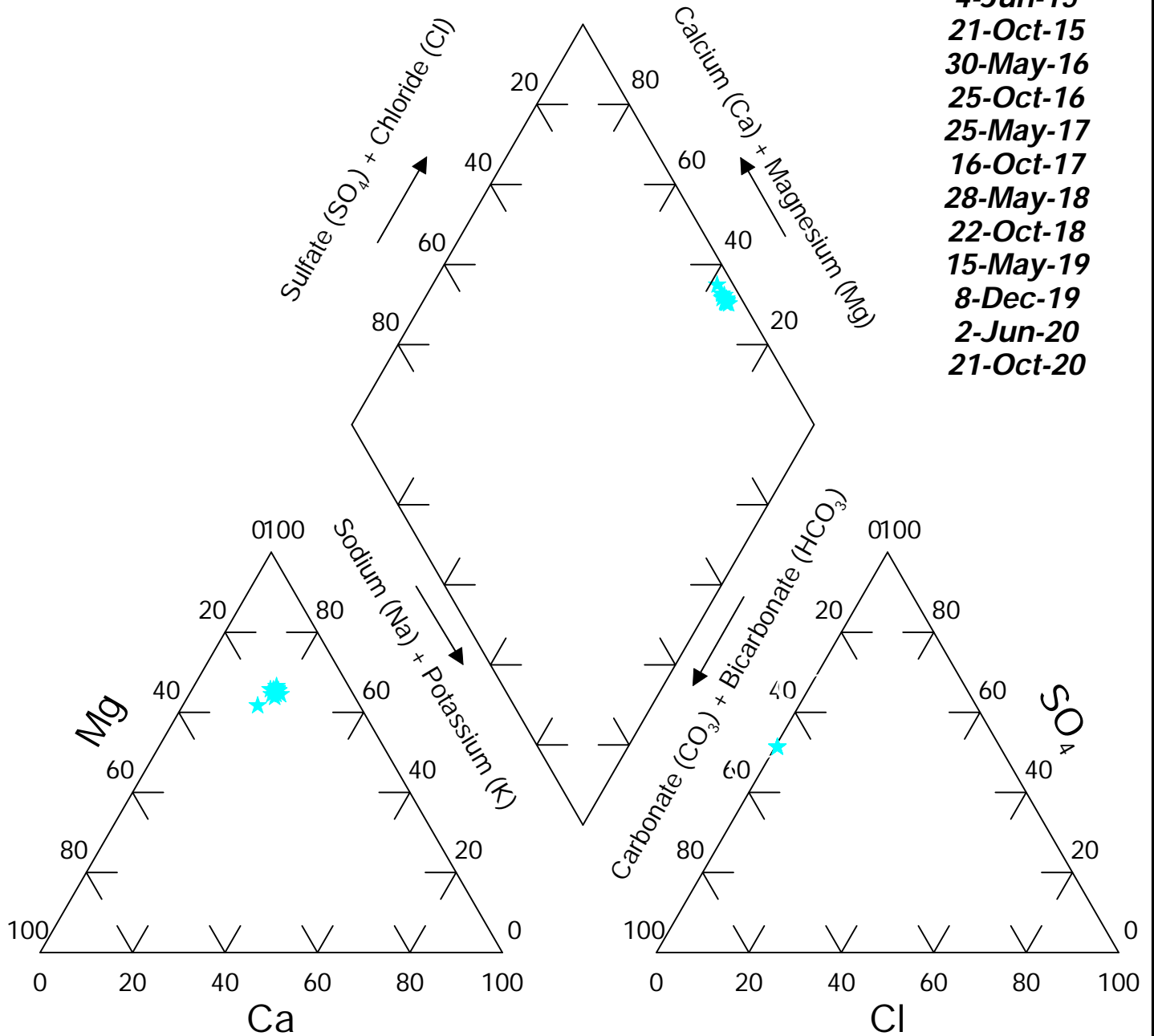

FIGURE: 4z

**2020 LEACHATE
PIPER DIAGRAMS**

Site: Brady
Location: MH3

Dates:
 2-Sep-15
 8-Sep-16
 26-Sep-17
 31-Jul-18
 11-Sep-19
 8-Sep-20

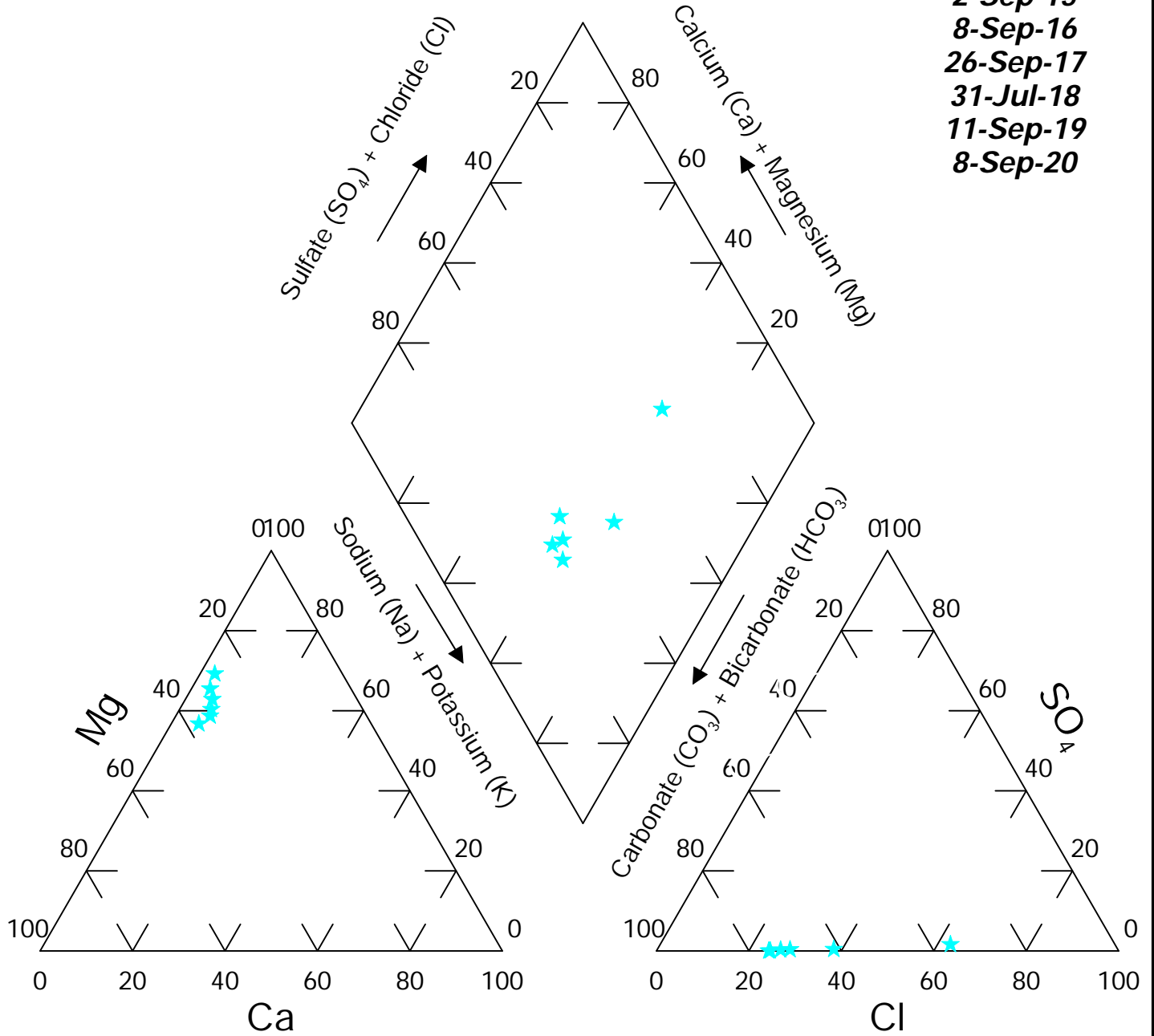

FIGURE: 18P

Site: Brady Location: MH8

Dates:
 2-Sep-15
 7-Sep-16
 26-Sep-17
 31-Jul-18
 11-Sep-19
 9-Sep-20

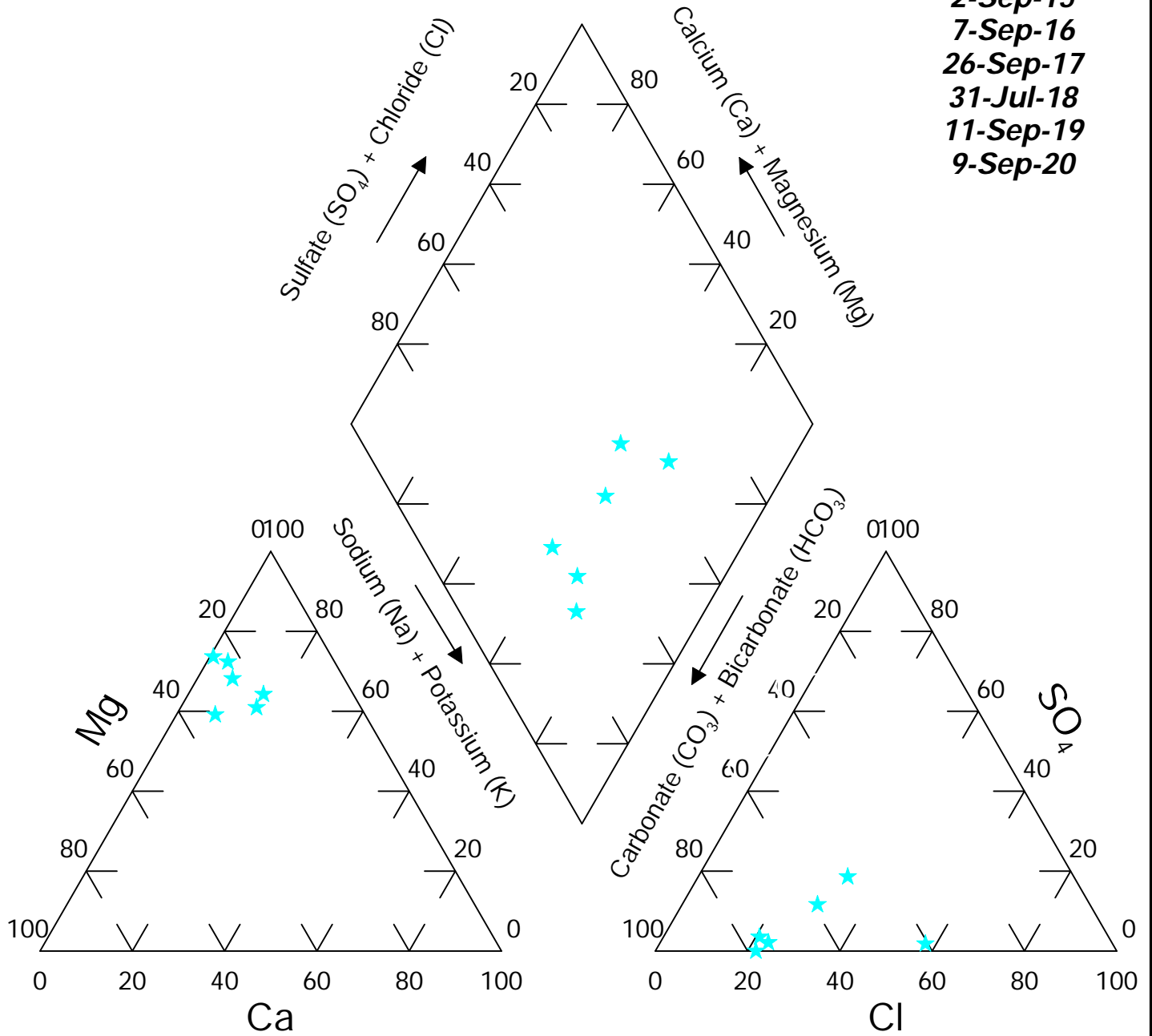

FIGURE: 19P

Site: Brady
Location: MH13

Dates:
 2-Sep-15
 9-Sep-16
 26-Sep-17
 31-Jul-18
 12-Sep-19
 8-Sep-20

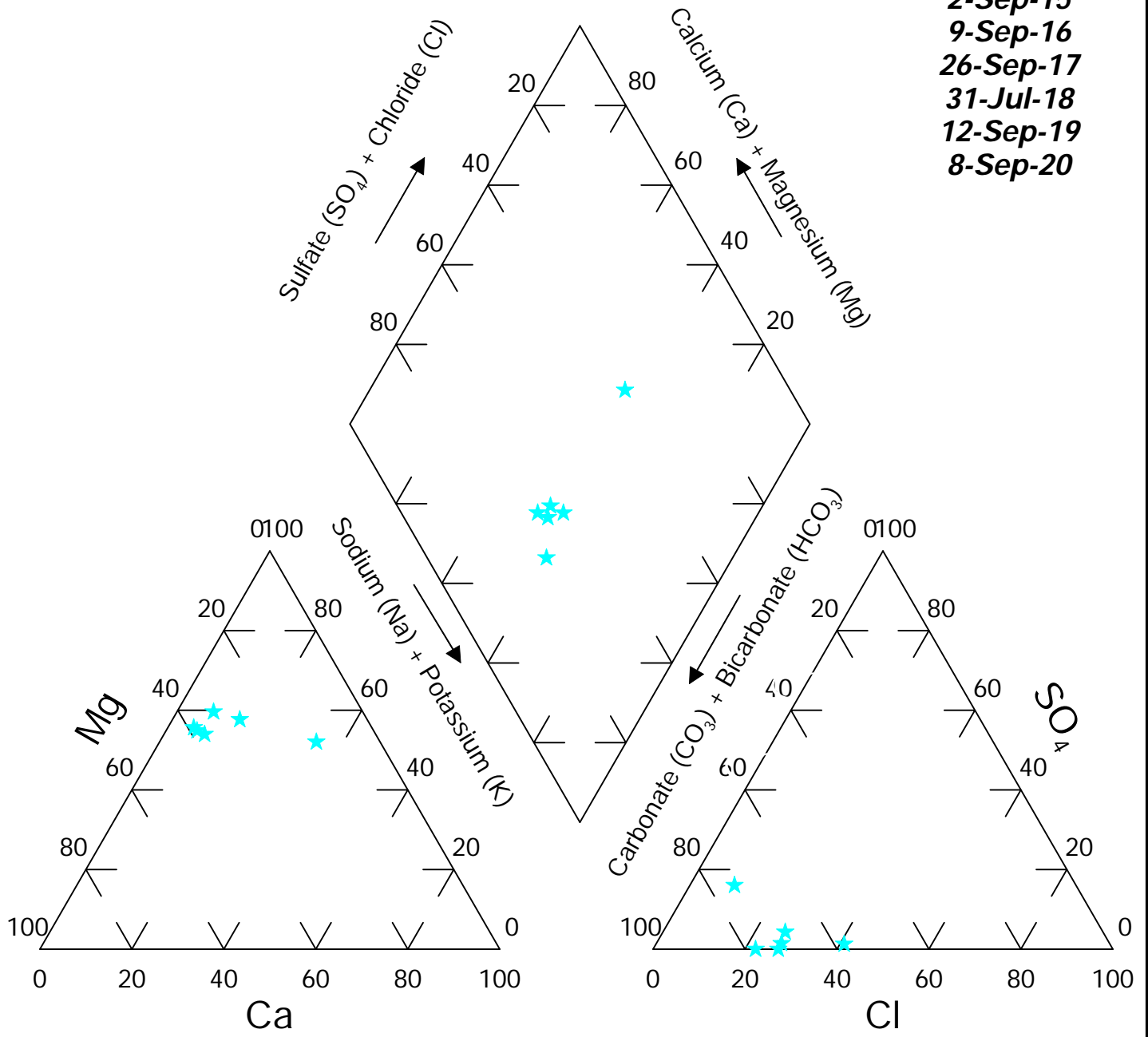

FIGURE: 20P

Site: Brady
Location: MH24

Dates:
 2-Sep-15
 7-Sep-16
 26-Sep-17
 31-Jul-18
 11-Sep-19
 8-Sep-20

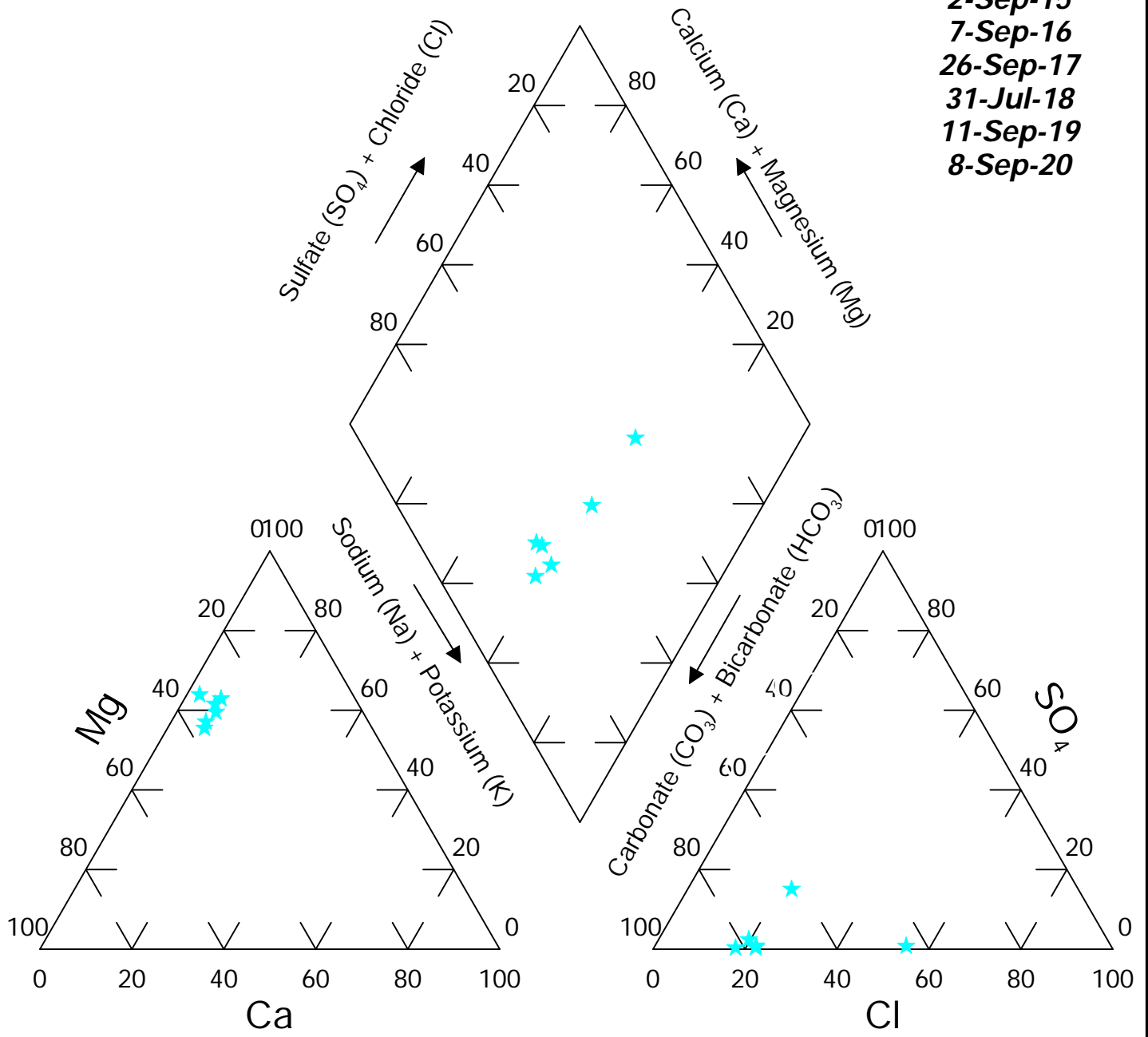

FIGURE: 21P

Site: Brady Location: MH27

Dates:
 2-Sep-15
 7-Sep-16
 26-Sep-17
 31-Jul-18
 11-Sep-19
 8-Sep-20

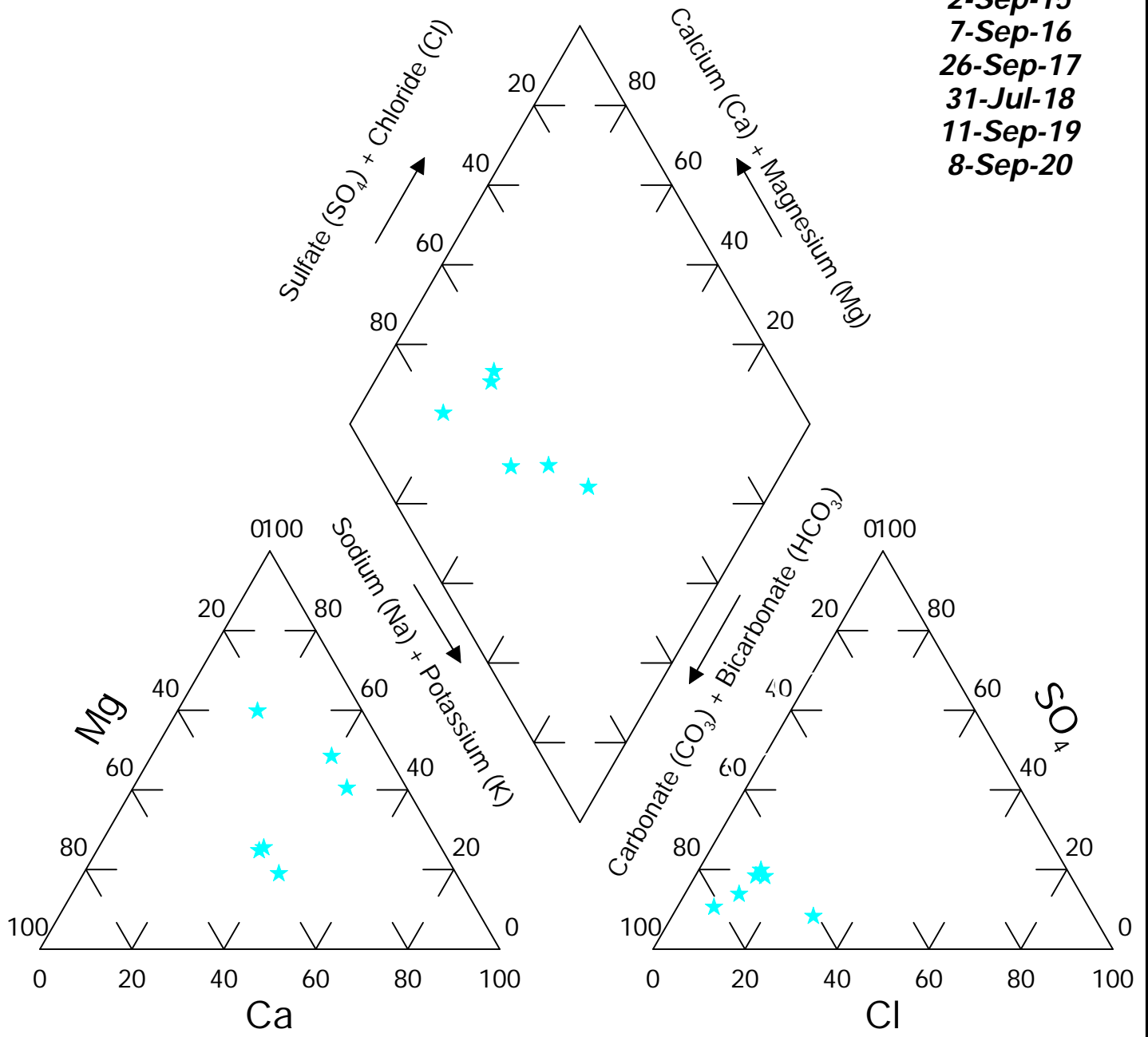

FIGURE: 22P

Site: Brady Location: MH31

Dates:
 2-Sep-15
 7-Sep-16
 26-Sep-17
 31-Jul-18
 11-Sep-19
 8-Sep-20

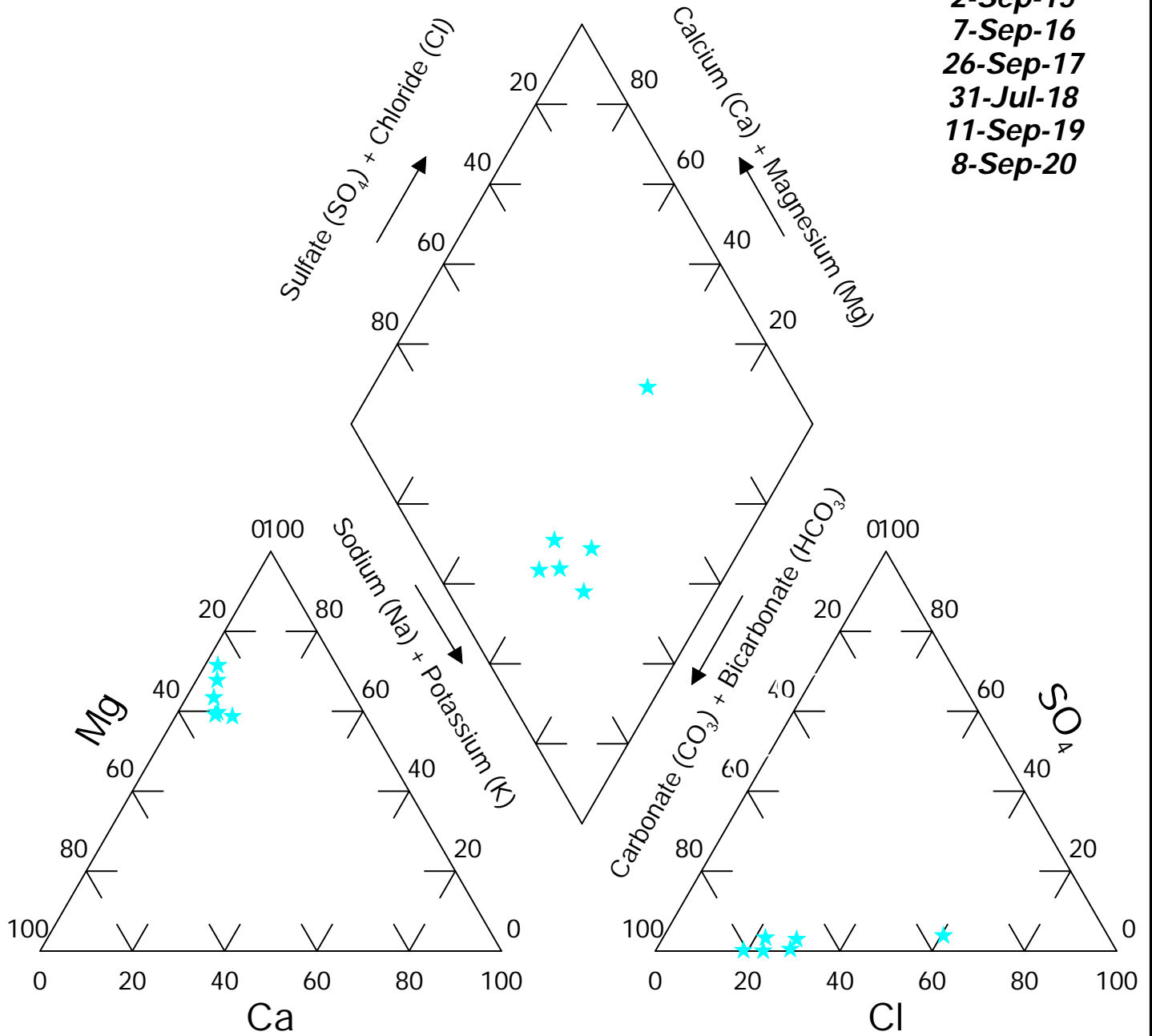

FIGURE: 23P

Site: Brady Location: MH34

Dates:
 2-Sep-15
 8-Sep-16
 26-Sep-17
 31-Jul-18
 11-Sep-19
 8-Sep-20

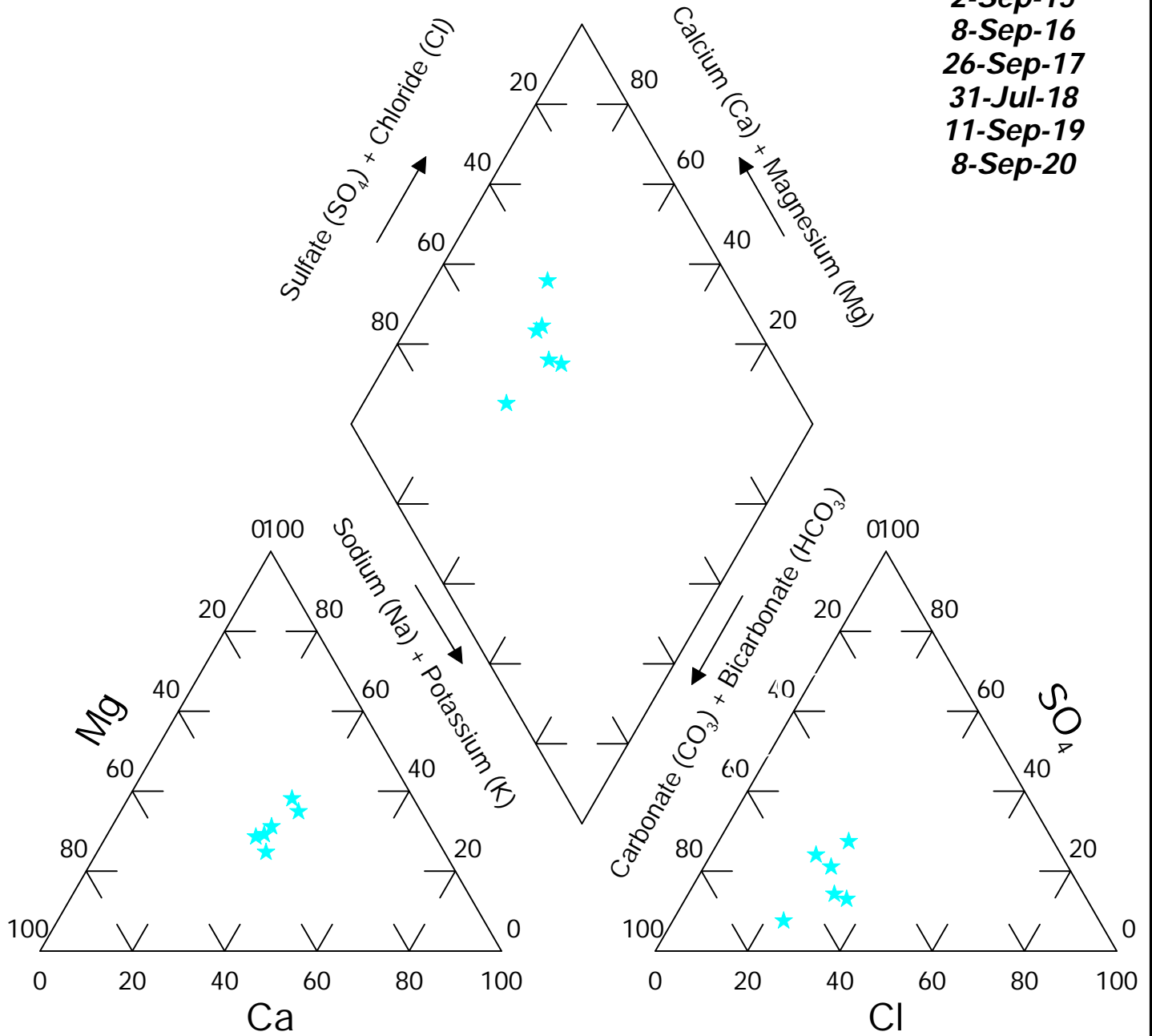

FIGURE: 24P

Site: Brady
Location: MH46

Date:
31-Jul-18
11-Sep-19

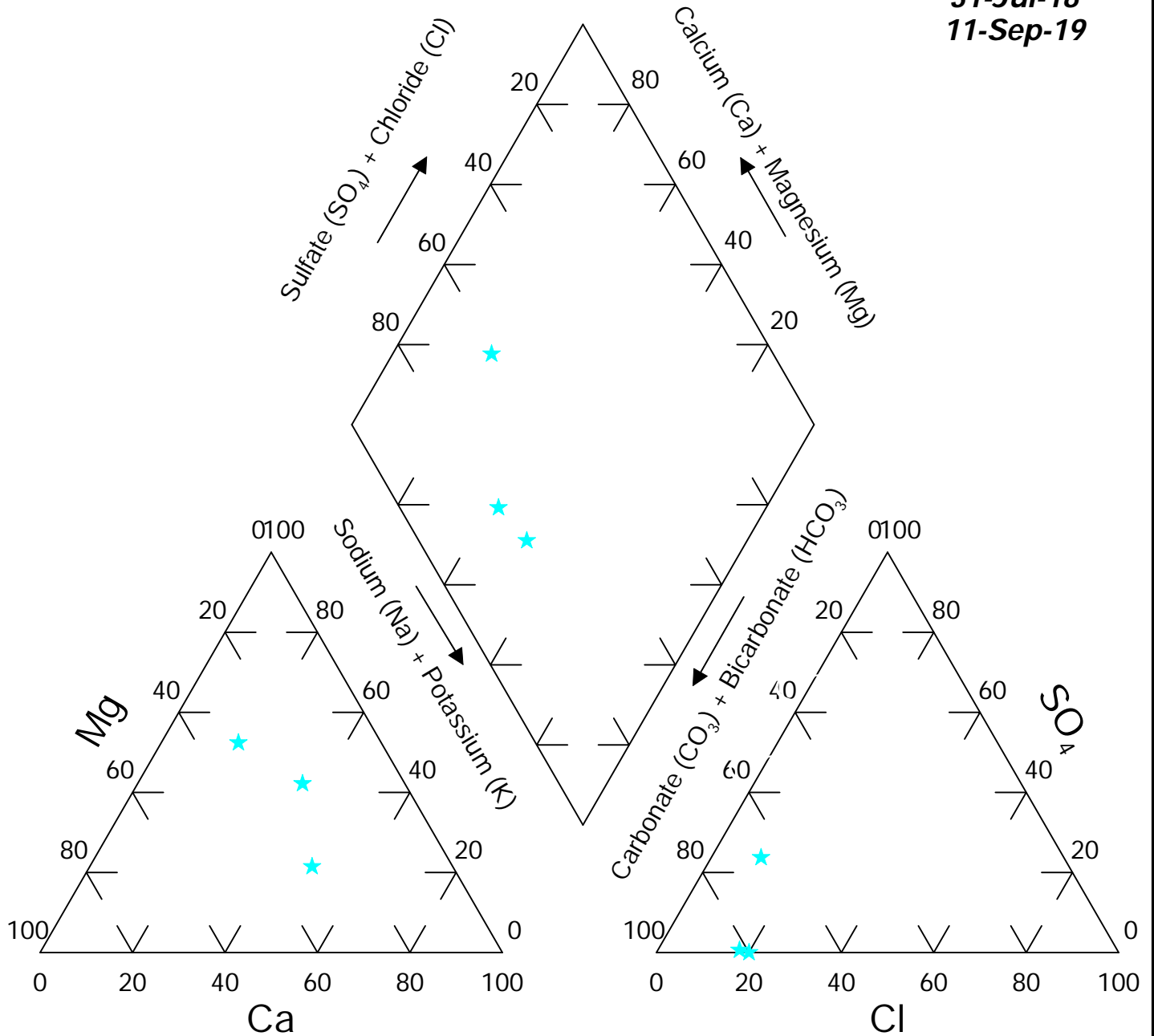

FIGURE: 21P

Site: Brady Location: *Riser 1*

Dates:
 29-Oct-15
 8-Sep-16
 26-Sep-17
 31-Jul-18
 10-Sep-19
 8-Sep-20

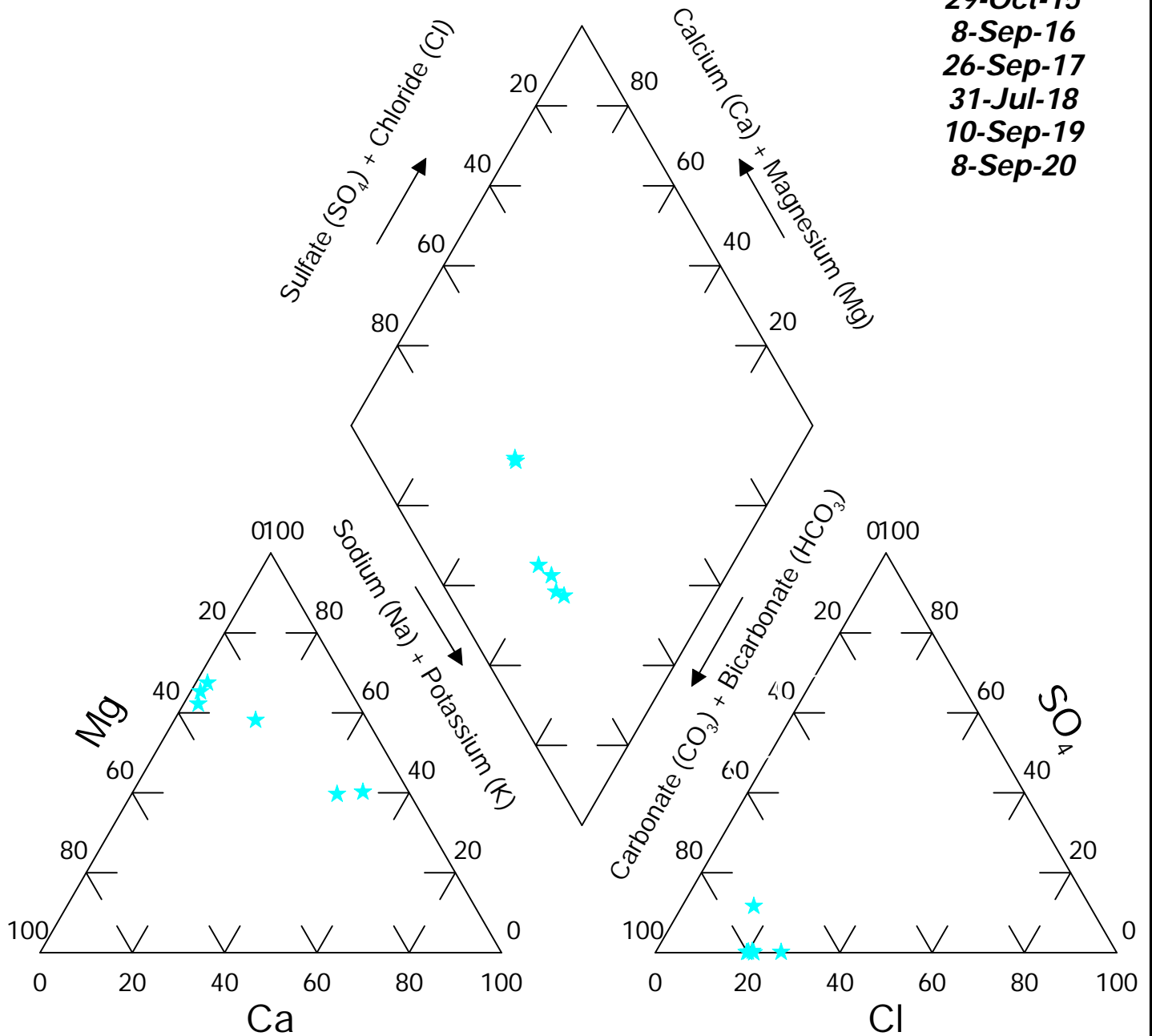

FIGURE: 18P

Site: Brady
Location: MH BIO

Dates:
 2-Sep-15
 8-Sep-16
 26-Sep-17
 31-Jul-18
 10-Sep-19
 8-Sep-20

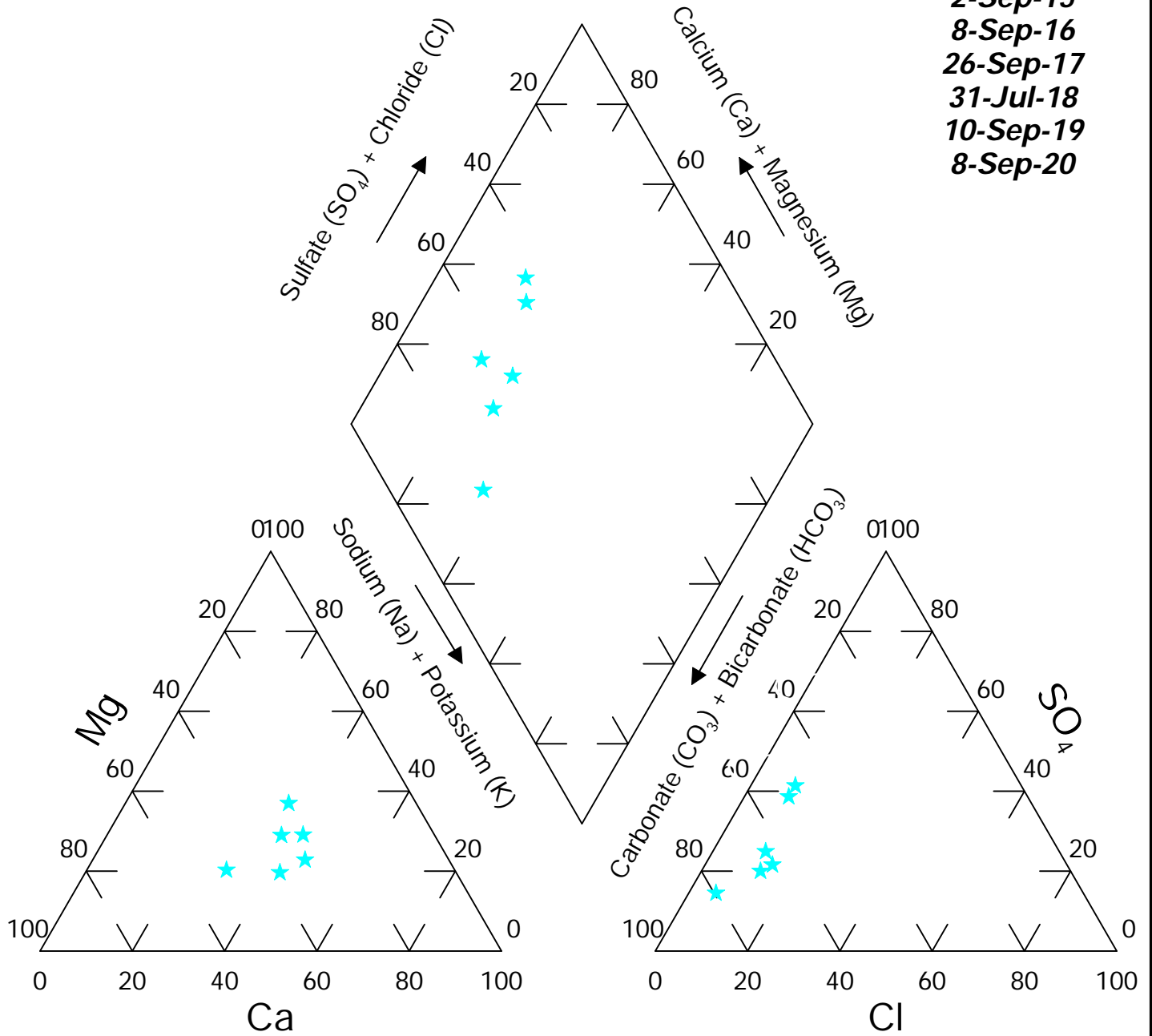
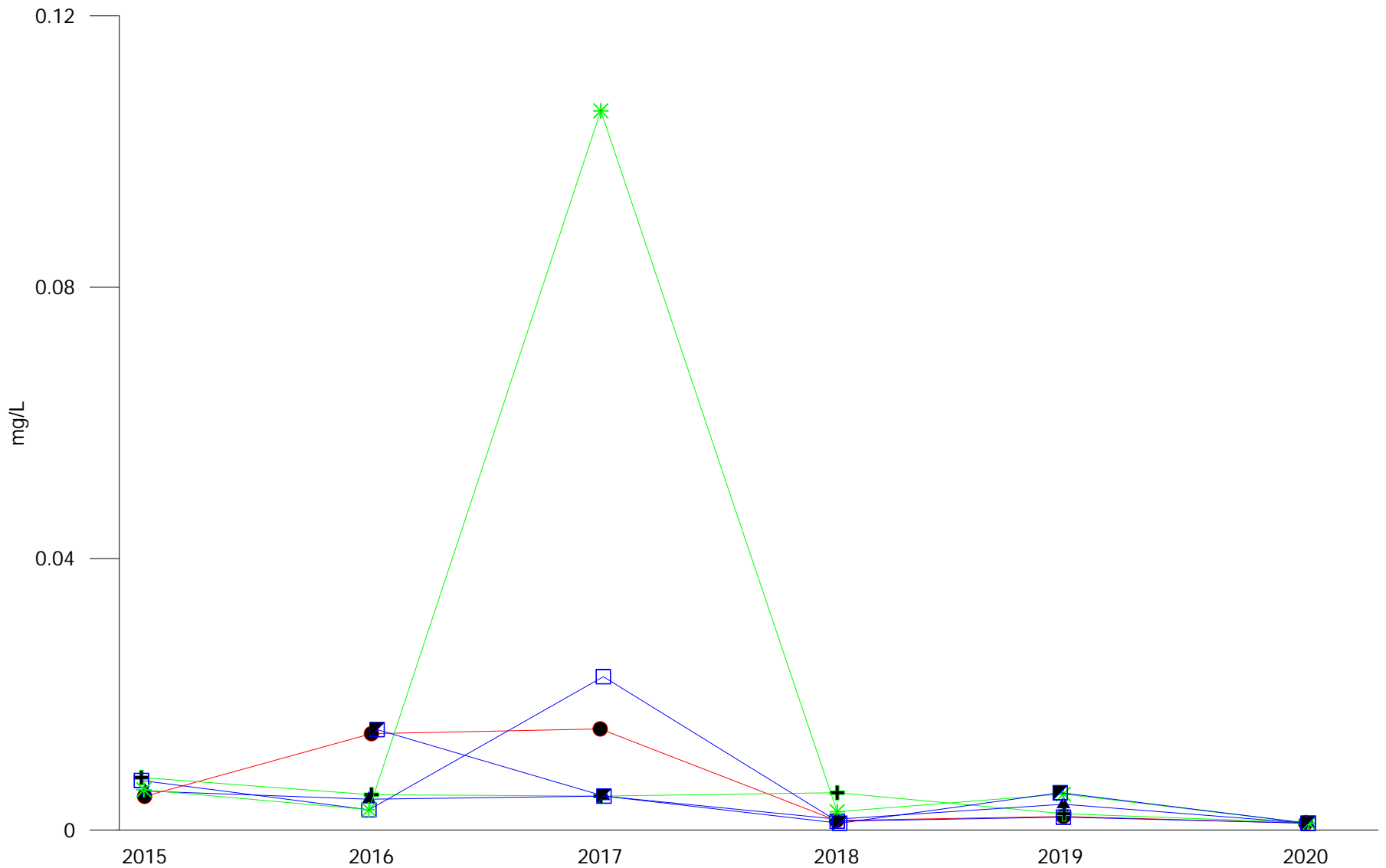

FIGURE: 18P

APPENDIX C
2020 TIME VS
CONCENTRATION GRAPHS

**2020 GROUNDWATER
TIME VS CONCENTRATION GRAPHS**



- + + + 5N62D Down Gradient
- * * * 6N67E Down Gradient
- ● ● 6060DR Up Gradient
- ▲ ▲ ▲ 6N57DR Cross Gradient
- □ □ 6N63E Cross Gradient
- ▣ ▣ ▣ 4N34C Cross Gradient

	City Of Winnipeg Solid Waste Services
BRADY ROAD RESOURCE MANAGEMENT FACILITY	
Dissolved Aluminium Clay Wells	
APRIL 2021	FIGURE 15
REV 0	

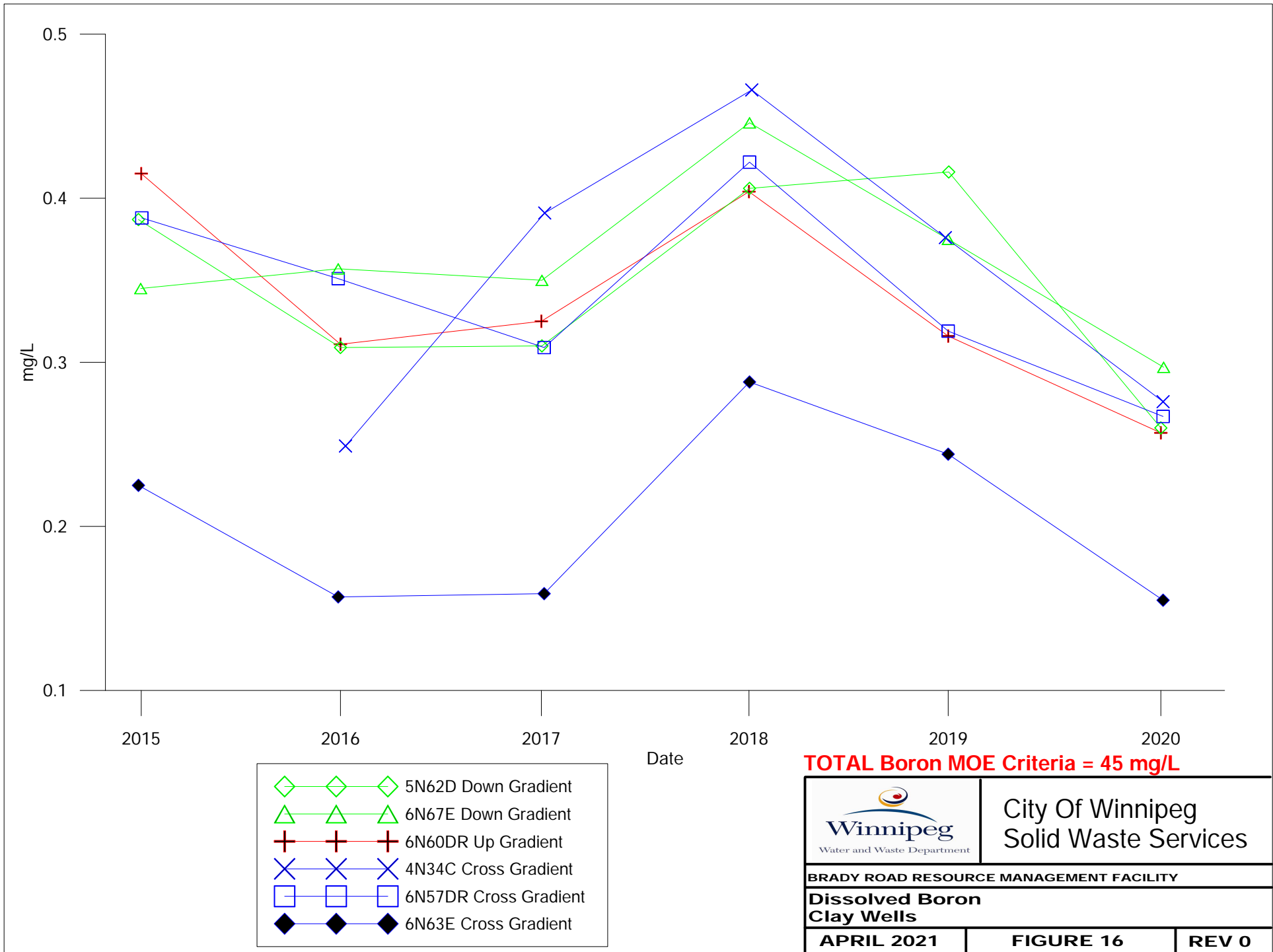

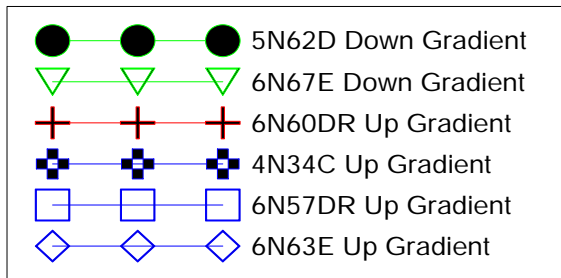

Barium MOE Criteria = 29 mg/L

	City Of Winnipeg Solid Waste Services	
	BRADY ROAD RESOURCE MANAGEMENT FACILITY	
Dissolved Barium Clay Wells		
APRIL 2021	FIGURE 17	REV 0

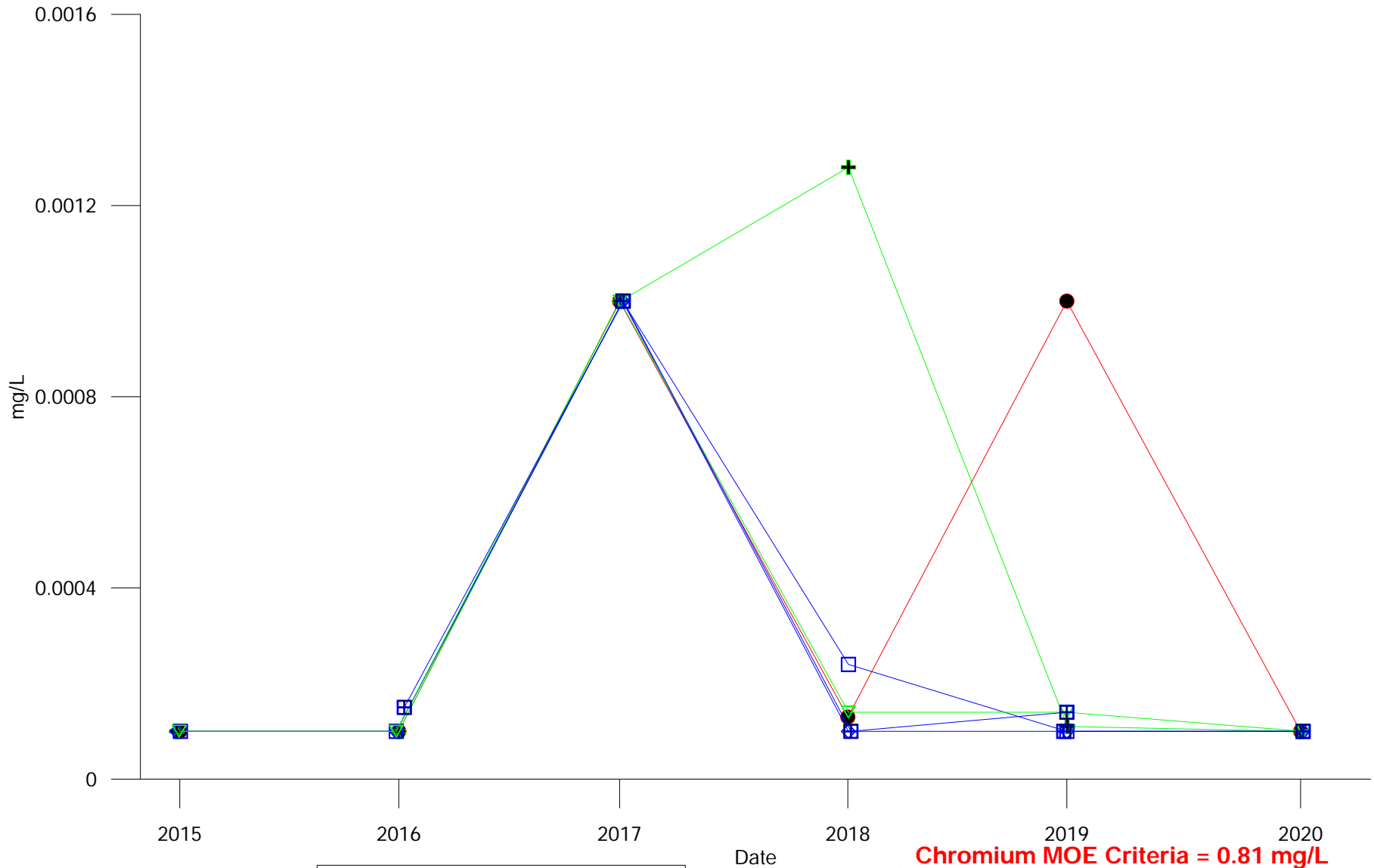

Chromium MOE Criteria = 0.81 mg/L

- + + + 5N62D Down Gradient
- ▽ ▽ ▽ 6N67E Down Gradient
- ● ● 6N60DR Up Gradient
- ⊠ ⊠ ⊠ 4N34C Cross Gradient
- □ □ 6N57DR Cross Gradient
- ◇ ◇ ◇ 6N63E Cross Gradient

 <p>Winnipeg Water and Waste Department</p>	<p>City Of Winnipeg Solid Waste Services</p>
<p>BRADY ROAD RESOURCE MANAGEMENT FACILITY</p>	
<p>Dissolved Chromium Clay Wells</p>	
<p>APRIL 2021</p>	<p>FIGURE 18</p>
<p>REV 0</p>	

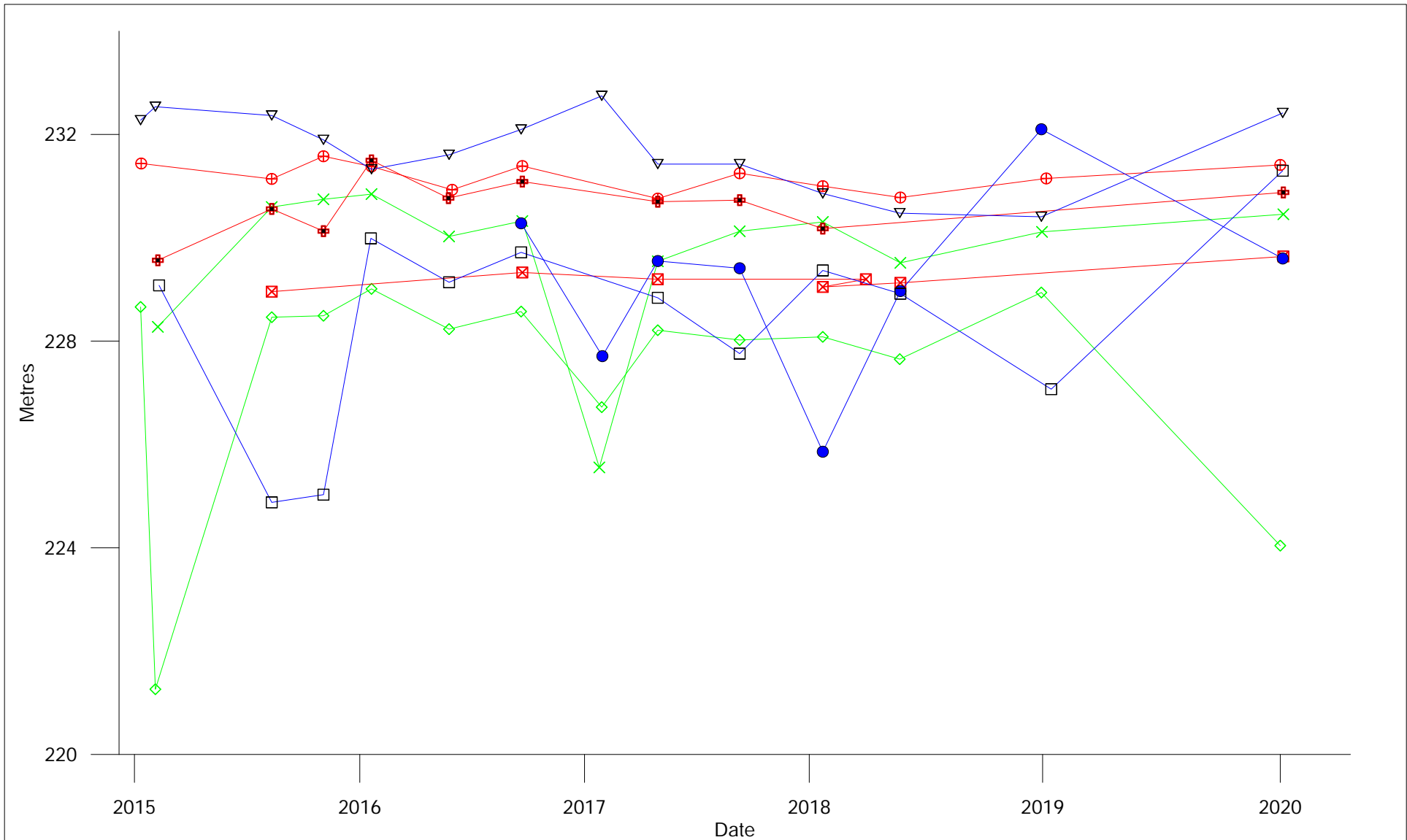

Down gradient

- 5N62D
- 6N67E

Cross gradient

- 4N34CR
- 6N57DR
- 6N63E

Up gradient

- 6N58DR
- 6N59DR
- 6N60DR



City Of Winnipeg
Solid Waste Services

BRADY ROAD RESOURCE MANAGEMENT FACILITY
**GROUNDWATER ELEVATIONS
 CLAY WELLS**
 APRIL 2021 | FIGURE GW-3-2 | REV 0

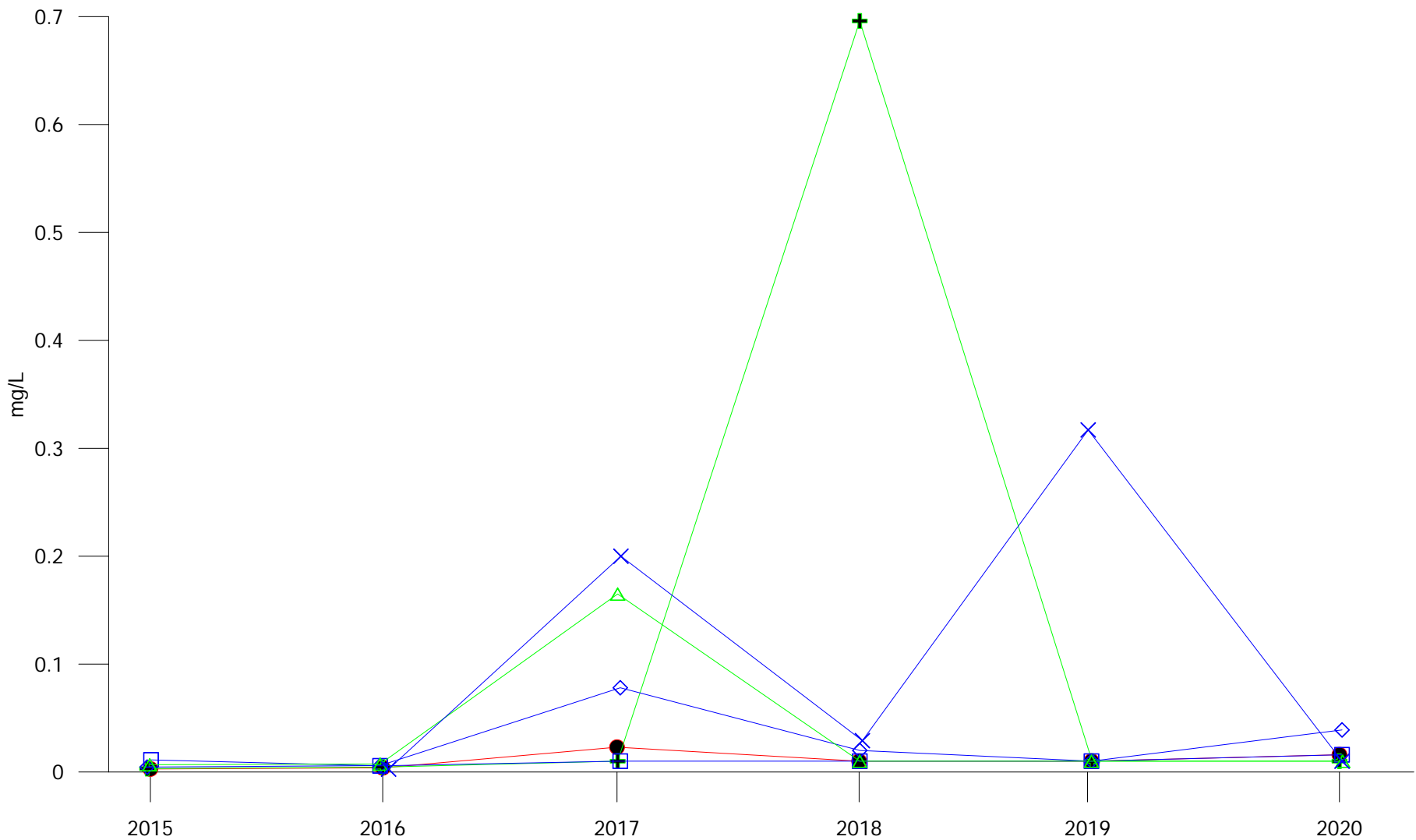

- + + + 5N62D Down Gradient
- △ △ △ 6N67E Down Gradient
- ● ● 6N60DR Up Gradient
- × × × 4N34C Up Gradient
- □ □ 6N57DR Up Gradient
- ◇ ◇ ◇ 6N63E Up Gradient

	City Of Winnipeg Solid Waste Services	
	BRADY ROAD RESOURCE MANAGEMENT FACILITY	
Dissolved Iron Clay Wells		
APRIL 2021	FIGURE 19	REV 0

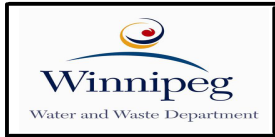
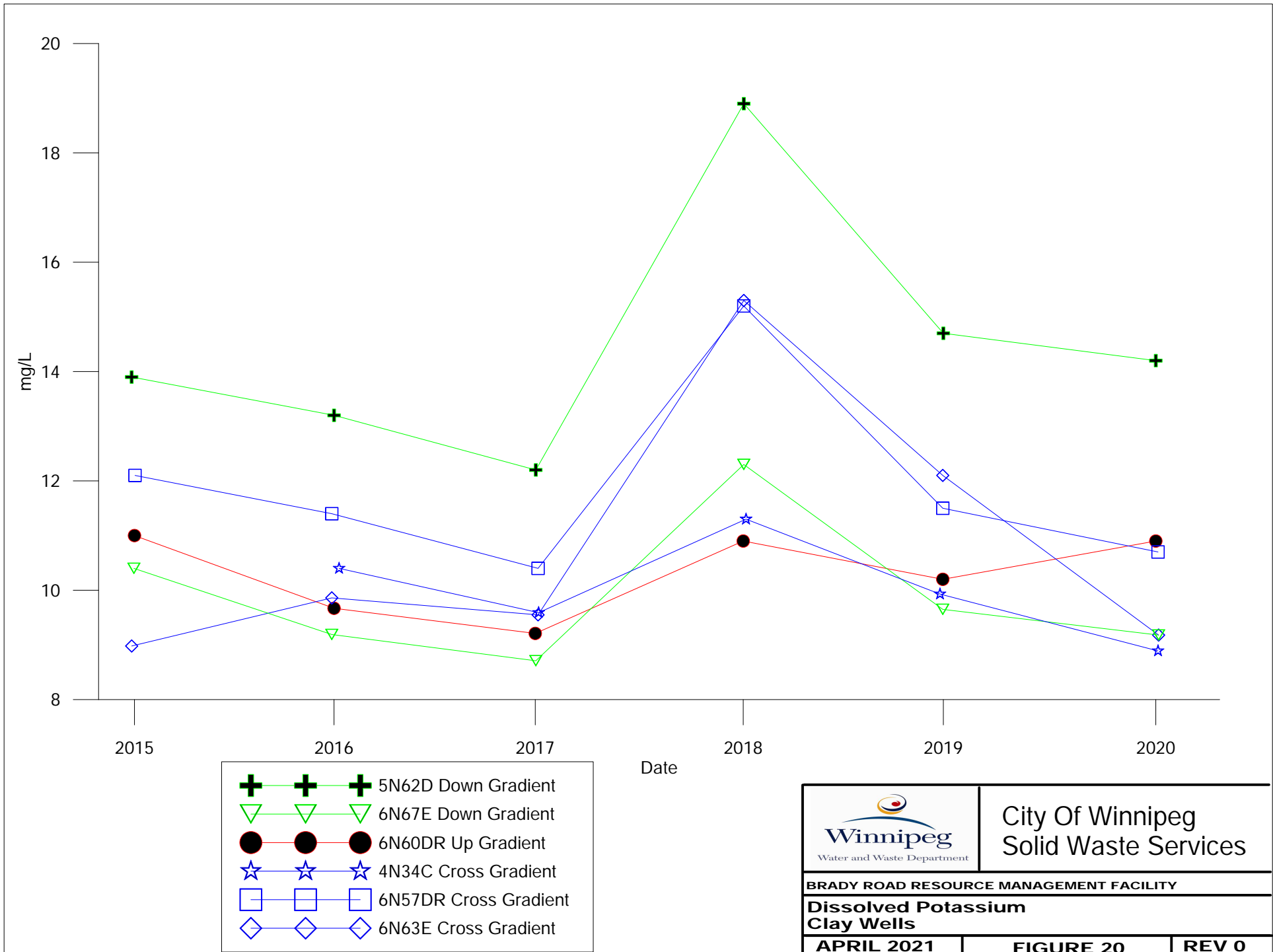

City Of Winnipeg
Solid Waste Services

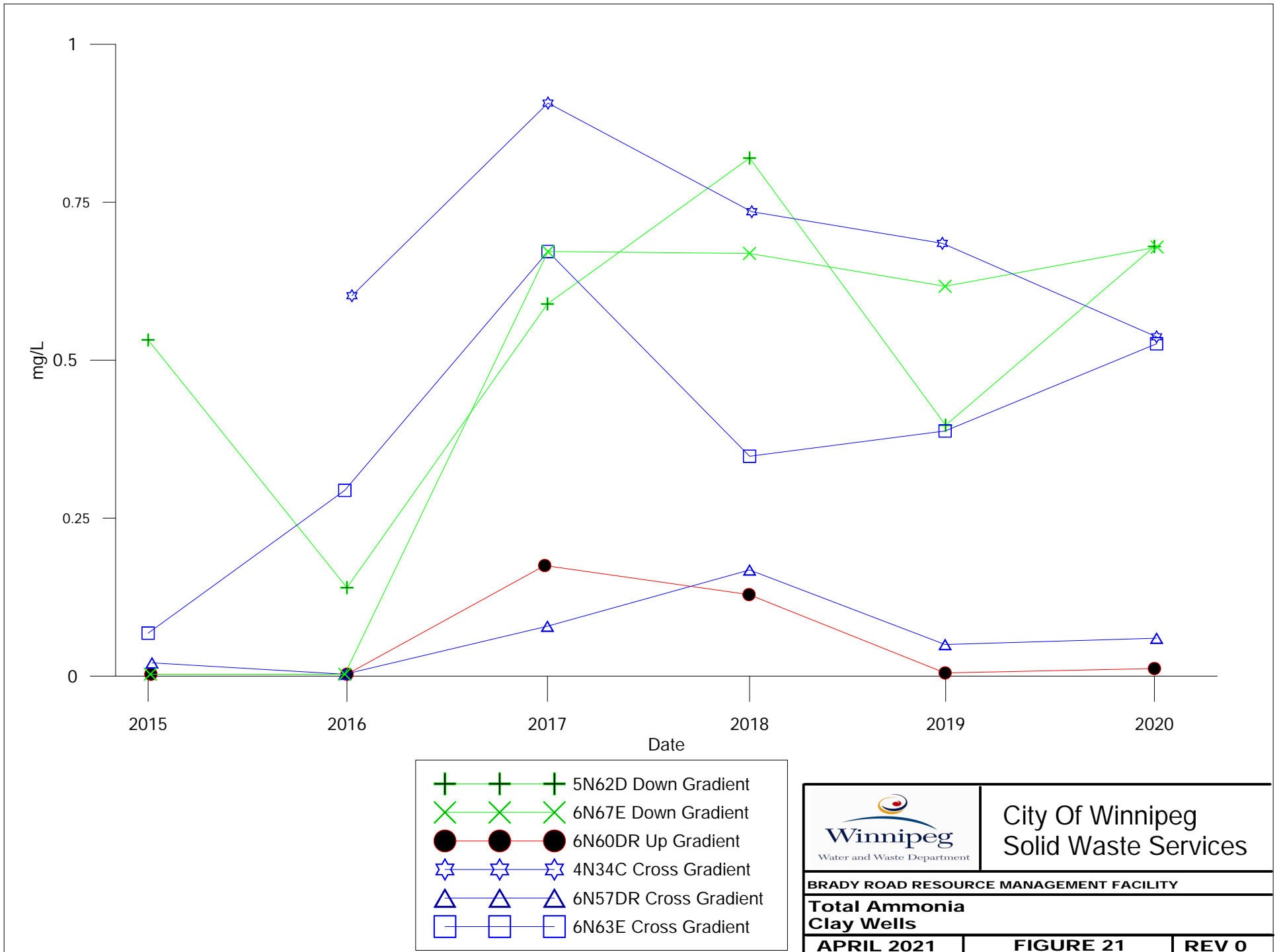

City Of Winnipeg
Solid Waste Services

BRADY ROAD RESOURCE MANAGEMENT FACILITY

**Total Ammonia
Clay Wells**

APRIL 2021

FIGURE 21

REV 0

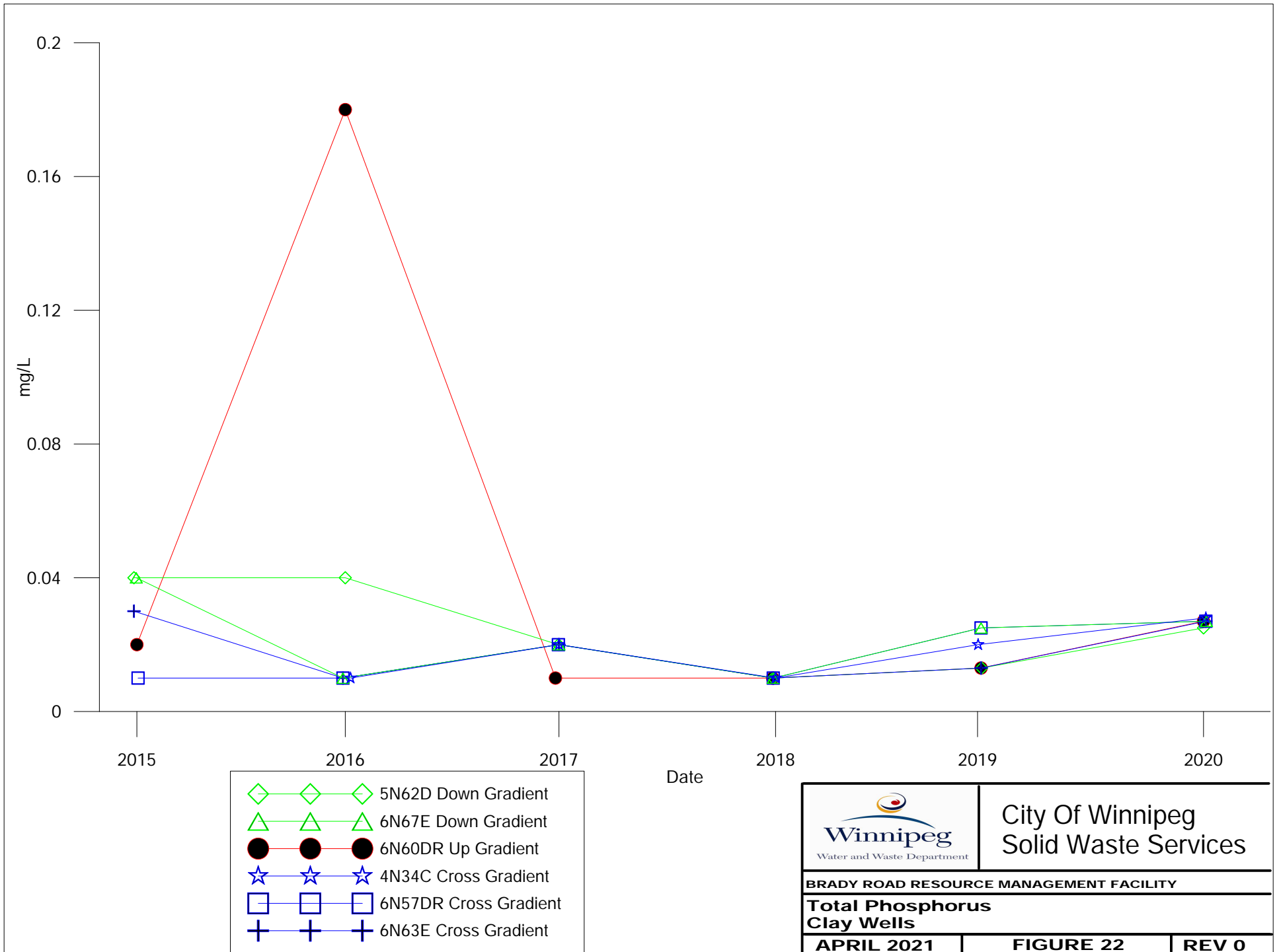

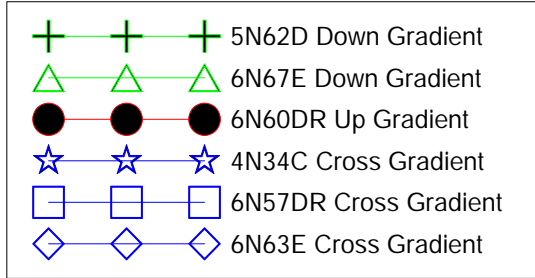

	City Of Winnipeg Solid Waste Services	
	BRADY ROAD RESOURCE MANAGEMENT FACILITY	
Dissolved Rubidium Clay Wells		
APRIL 2021	FIGURE 23	REV 0

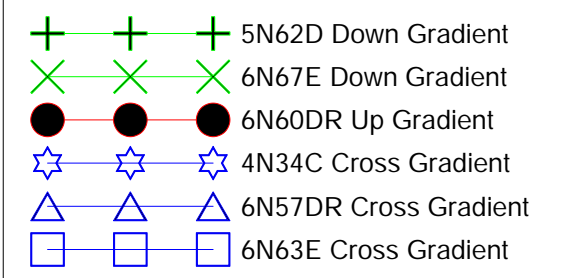
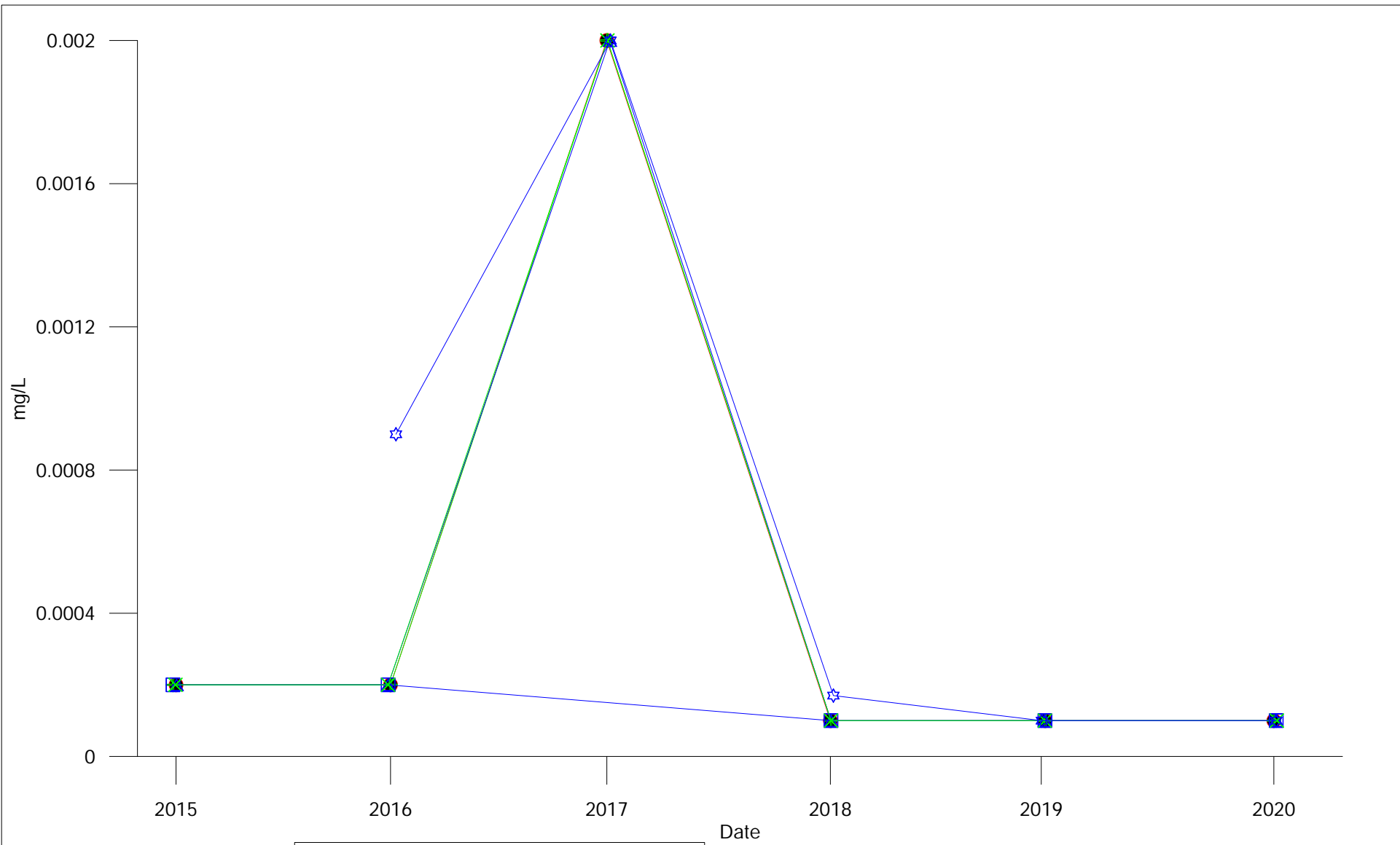

	City Of Winnipeg Solid Waste Services	
	BRADY ROAD RESOURCE MANAGEMENT FACILITY	
Dissolved Tin Clay Wells		
APRIL 2021	FIGURE 24	REV 0

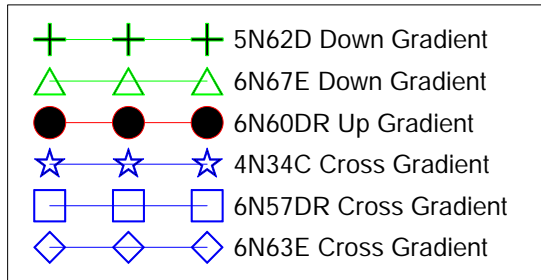

City Of Winnipeg
Solid Waste Services

BRADY ROAD RESOURCE MANAGEMENT FACILITY

Total Kjeldahl Nitrogen
Clay Wells

APRIL 2021

FIGURE 25

REV 0

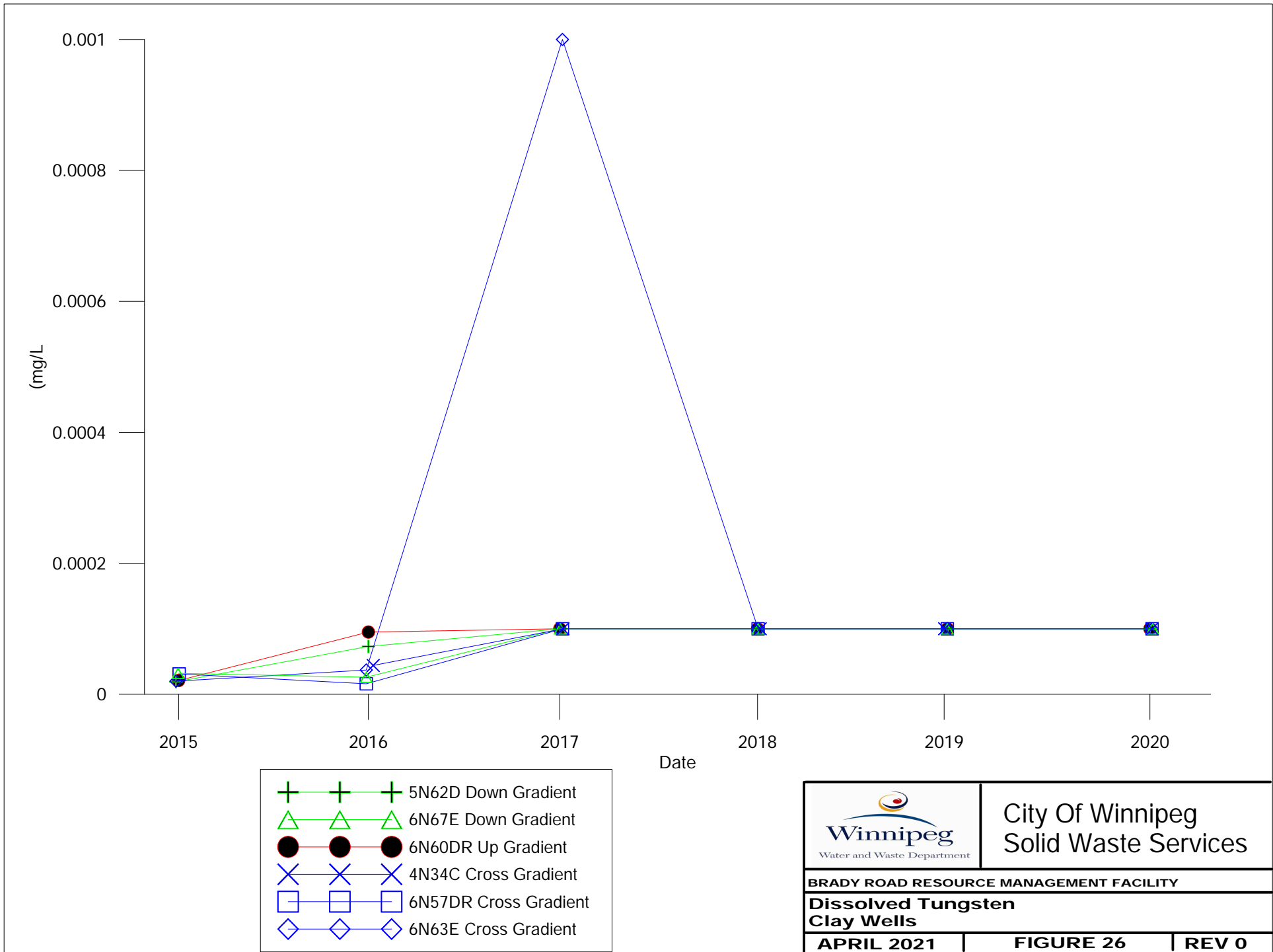

	City Of Winnipeg Solid Waste Services	
	BRADY ROAD RESOURCE MANAGEMENT FACILITY	
Dissolved Tungsten Clay Wells		
APRIL 2021	FIGURE 26	REV 0

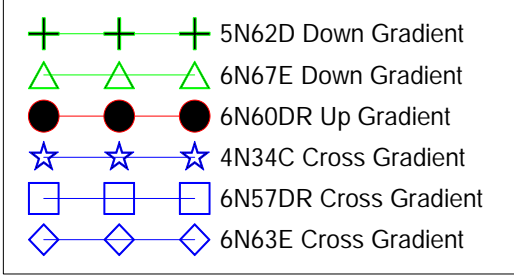
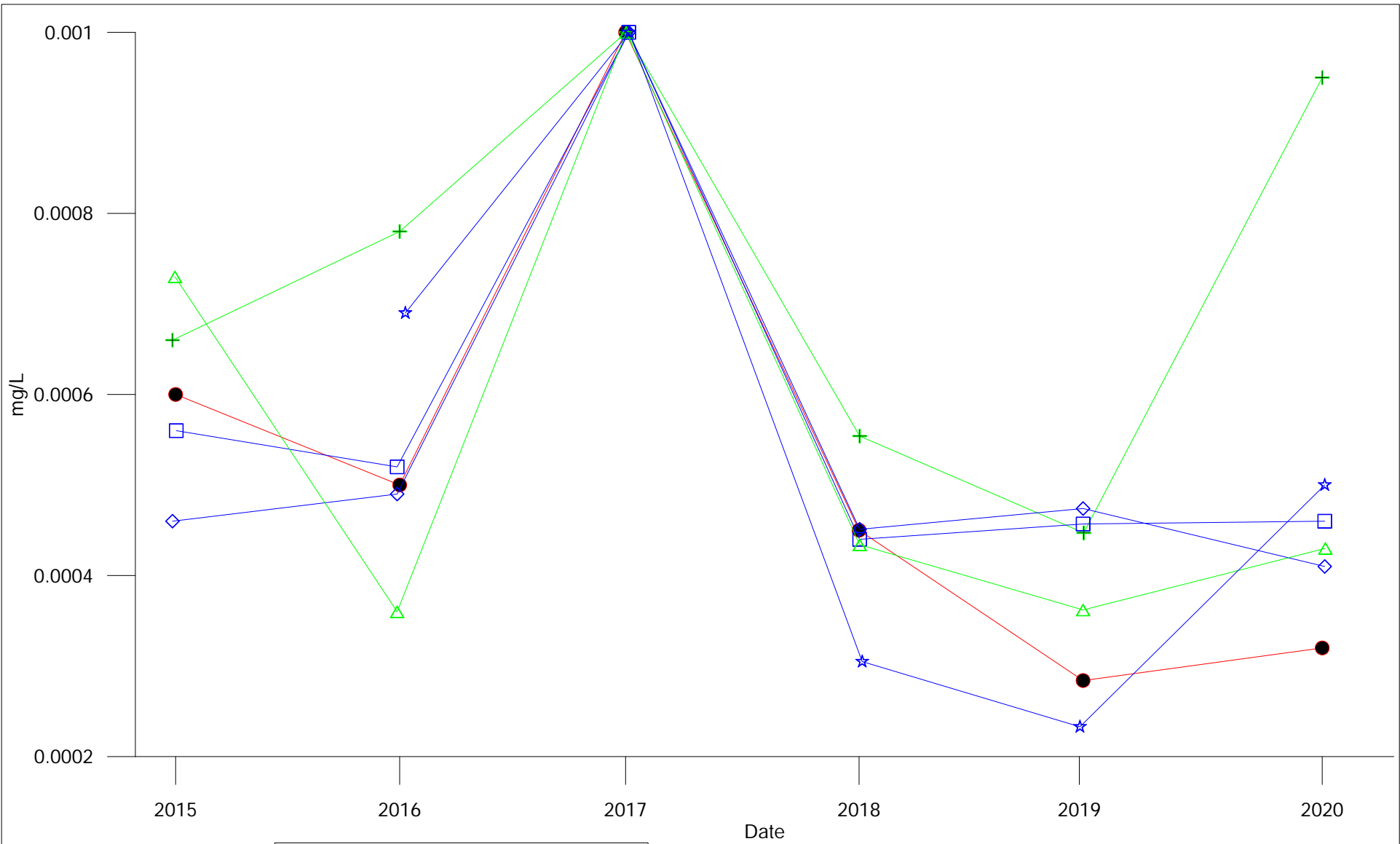

	City Of Winnipeg Solid Waste Services	
	BRADY ROAD RESOURCE MANAGEMENT FACILITY	
Dissolved Zirconium Clay Wells		
APRIL 2021	FIGURE 27	REV 0

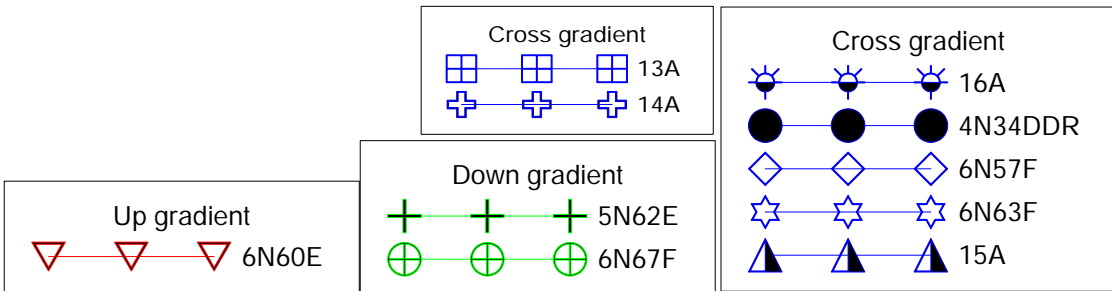
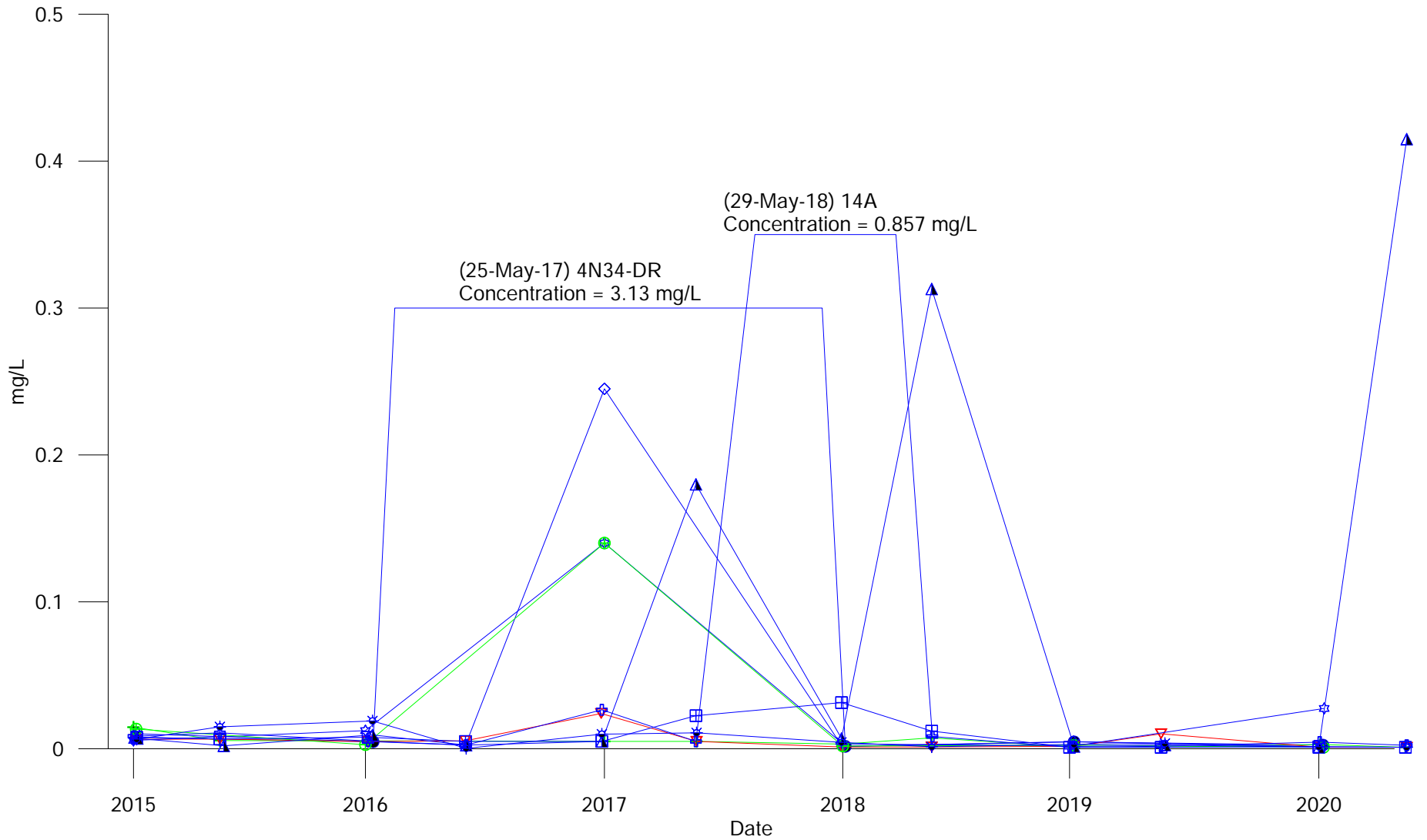

City Of Winnipeg
Solid Waste Services

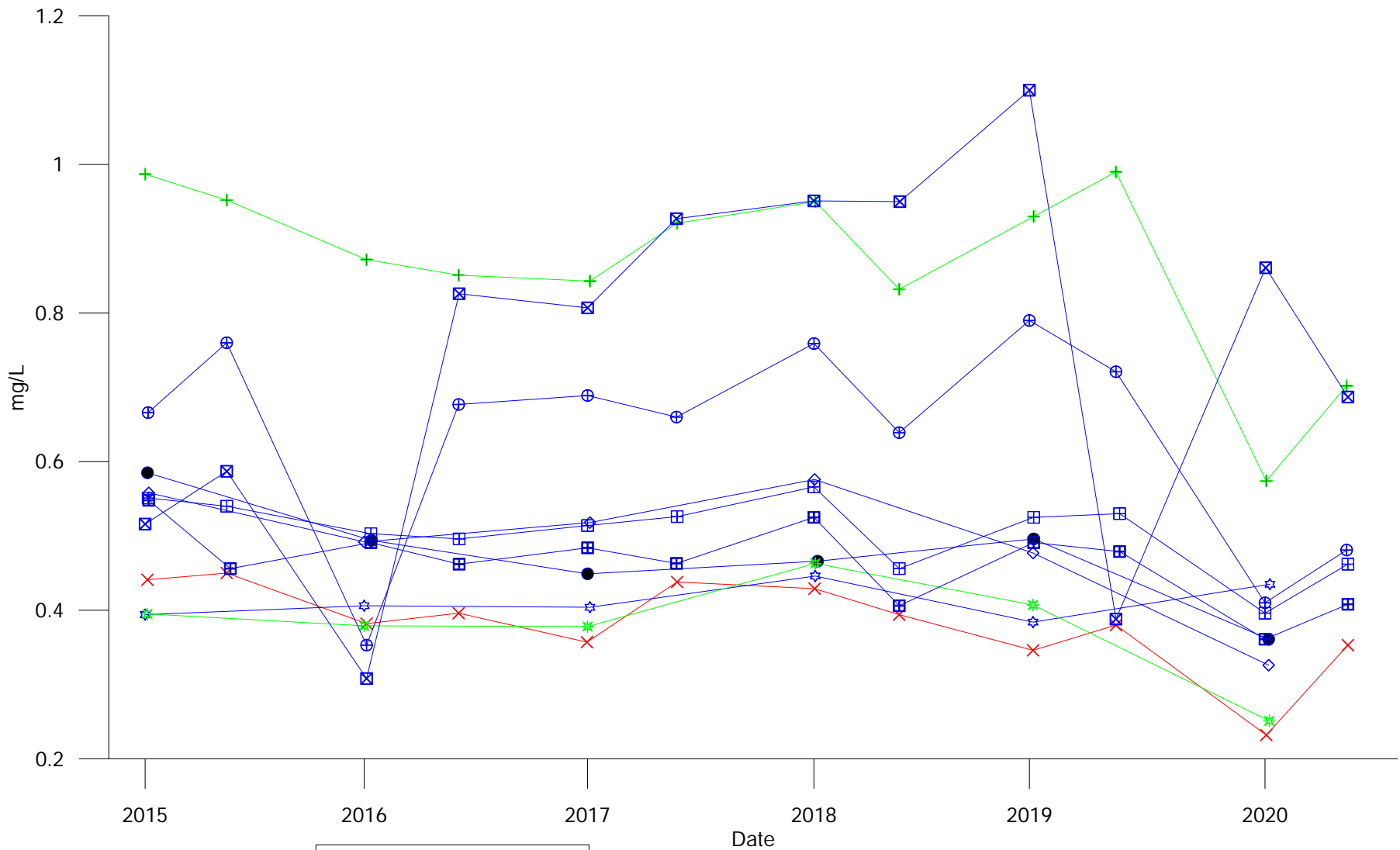

Up gradient
 X X X 6N60EER

Down gradient
 + + + 5N62E
 * * * 6N67F

Cross gradient
 ⊕ ⊕ ⊕ 13A
 ⊠ ⊠ ⊠ 14A

Cross gradient
 ⊞ ⊞ ⊞ 15A
 ⊠ ⊠ ⊠ 16A
 ● ● ● 4N34DDR
 ◇ ◇ ◇ 6N57F
 ☆ ☆ ☆ 6N63F

Boron MOE Criteria = 45 mg/L

	City Of Winnipeg Solid Waste Services	
	BRADY ROAD RESOURCE MANAGEMENT FACILITY	
Dissolved Boron Till Wells		
APRIL 2021	FIGURE 29	REV 0

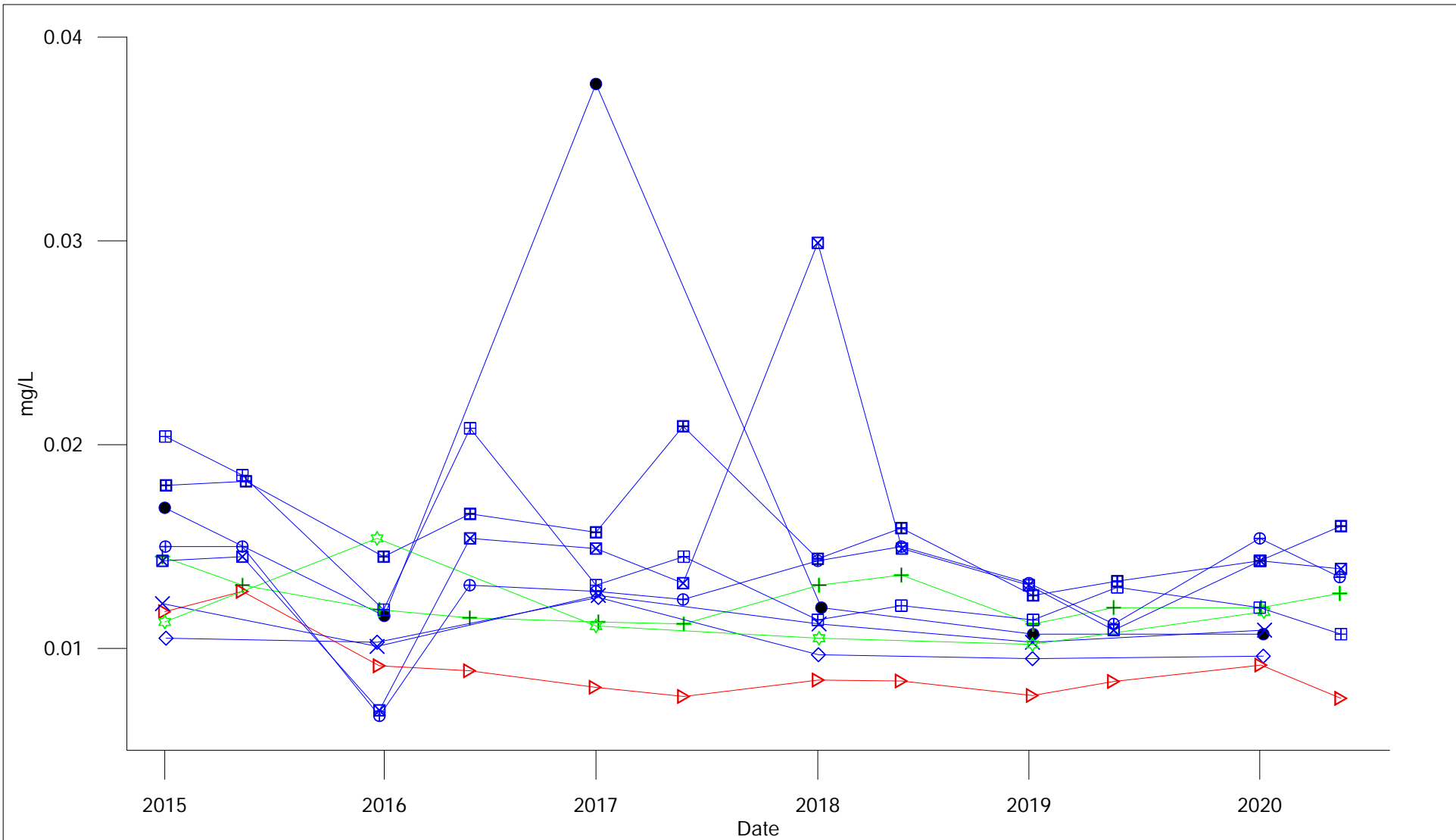

Up gradient
 6N60EER

Down gradient
 5N62E
 6N67F

Cross gradient
 13A
 14A

Cross gradient
 15A
 16A
 4N34DDR
 6N57F
 6N63F

Barium MOE Criteria = 29 mg/L

	City Of Winnipeg Solid Waste Services	
	BRADY ROAD RESOURCE MANAGEMENT FACILITY	
Dissolved Barium Till Wells		
APRIL 2021	FIGURE 30	REV 0

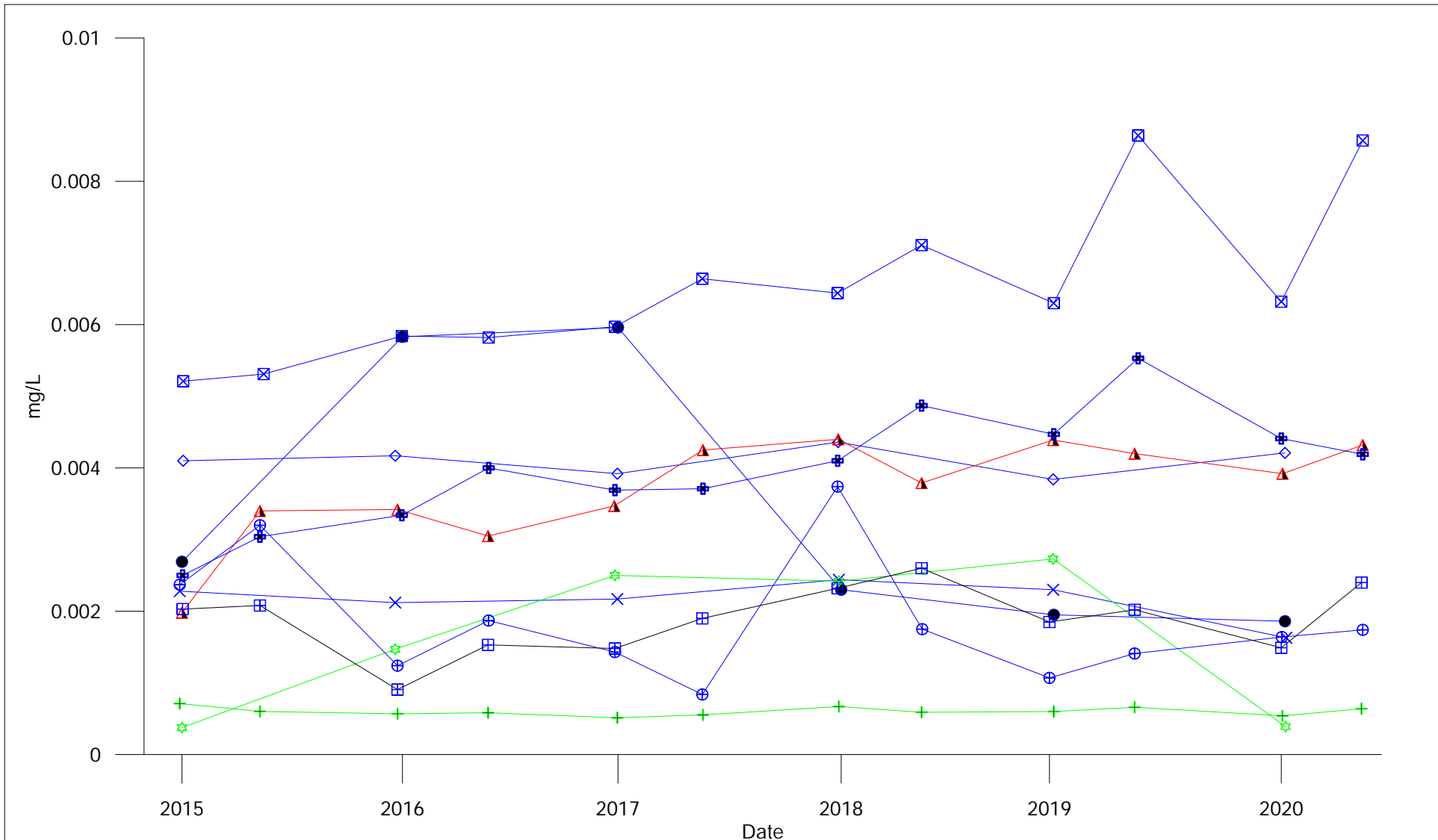

Up gradient
 6N60EER

Down gradient
 5N62E
 6N67F

Cross gradient
 13A
 14A

Cross gradient
 15A
 16A
 4N34DDR
 6N57F
 6N63F

Cobalt MOE Criteria = 0.066 mg/L

	City Of Winnipeg Solid Waste Services	
	BRADY ROAD RESOURCE MANAGEMENT FACILITY	
Dissolved Cobalt Till Wells		
APRIL 2021	FIGURE 31	REV 0

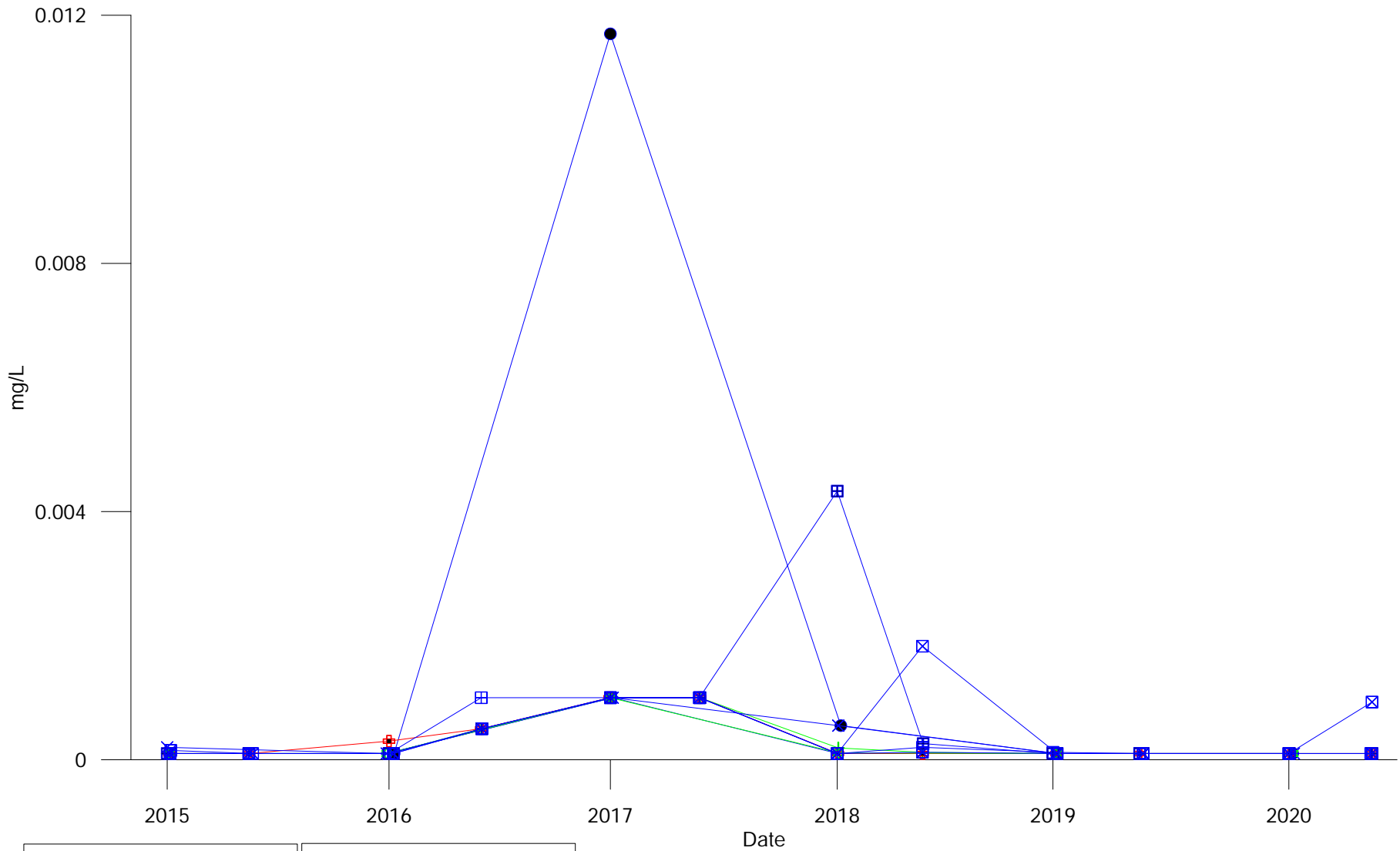

Up gradient
 6N60E

Down gradient
 5N62E
 6N67F

Cross gradient
 13A
 14A

Cross gradient
 15A
 16A
 4N34DDR
 6N57F
 6N63F

Chromium MOE Criteria = 0.81 mg/L

	City Of Winnipeg Solid Waste Services	
	BRADY ROAD RESOURCE MANAGEMENT FACILITY	
Dissolved Chromium Till Wells		
APRIL 2021	FIGURE 32	REV 0

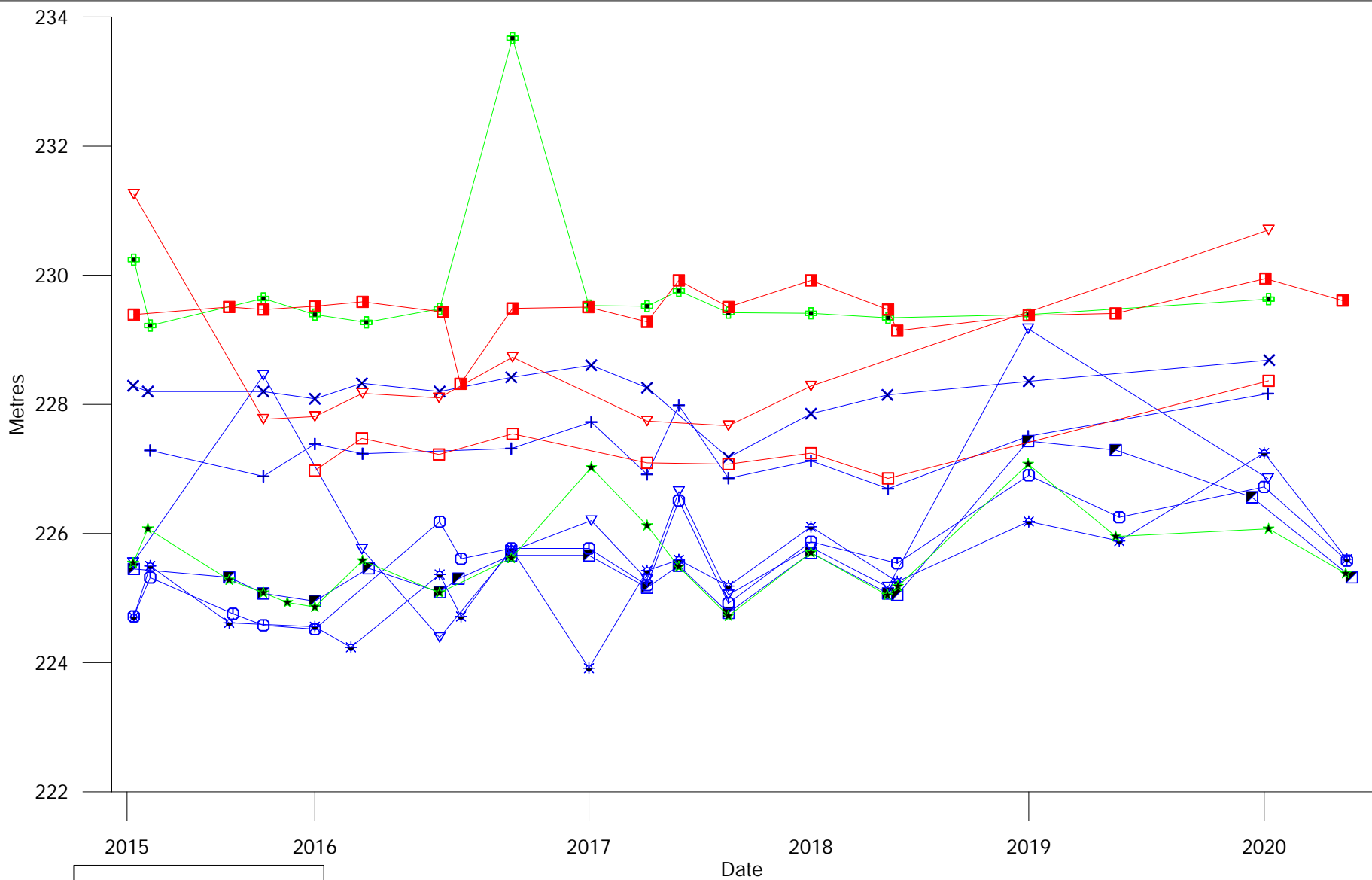

Cross gradient		
		13A
		15A
		6N57FR
		16A
		4N34DR
		6N63F

Up gradient		
		6N58FR
		6N59FR
		6N60ER

Down gradient		
		5N62E
		6N67F

	City Of Winnipeg Solid Waste Services	
	BRADY ROAD RESOURCE MANAGEMENT FACILITY	
GROUNDWATER ELEVATION TILL WELLS		
APRIL 2021	FIGURE GW-1-1	REV 0

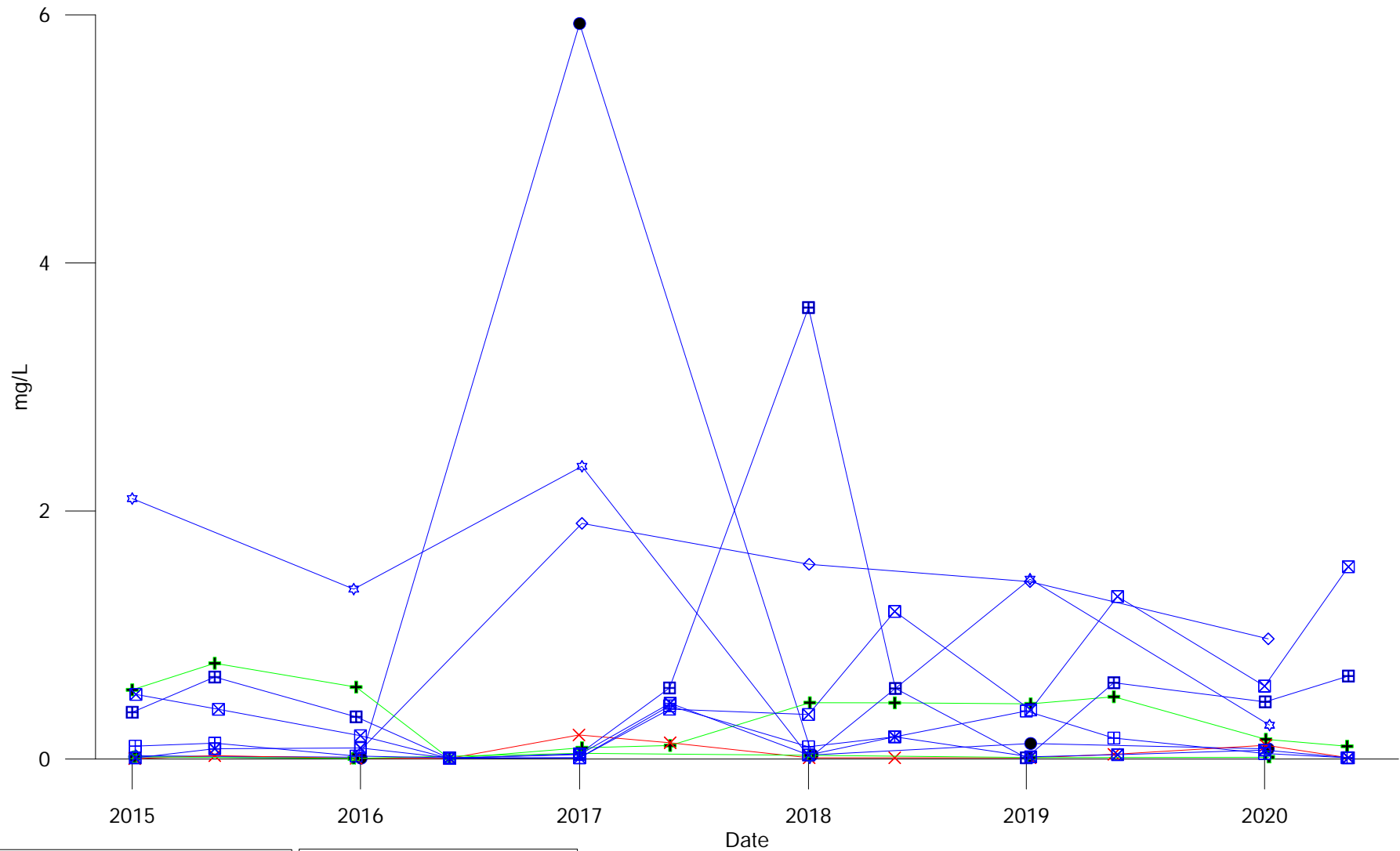

Up gradient
 X X X 6N60EER

Down gradient
 + + + 5N62E
 + + + 6N67F

Cross gradient
 □ □ □ 13A
 □ □ □ 14A

Cross gradient
 □ □ □ 15A
 □ □ □ 16A
 ● ● ● 4N34DDR
 ◇ ◇ ◇ 6N57F
 ☆ ☆ ☆ 6N63F



City Of Winnipeg
 Solid Waste Services

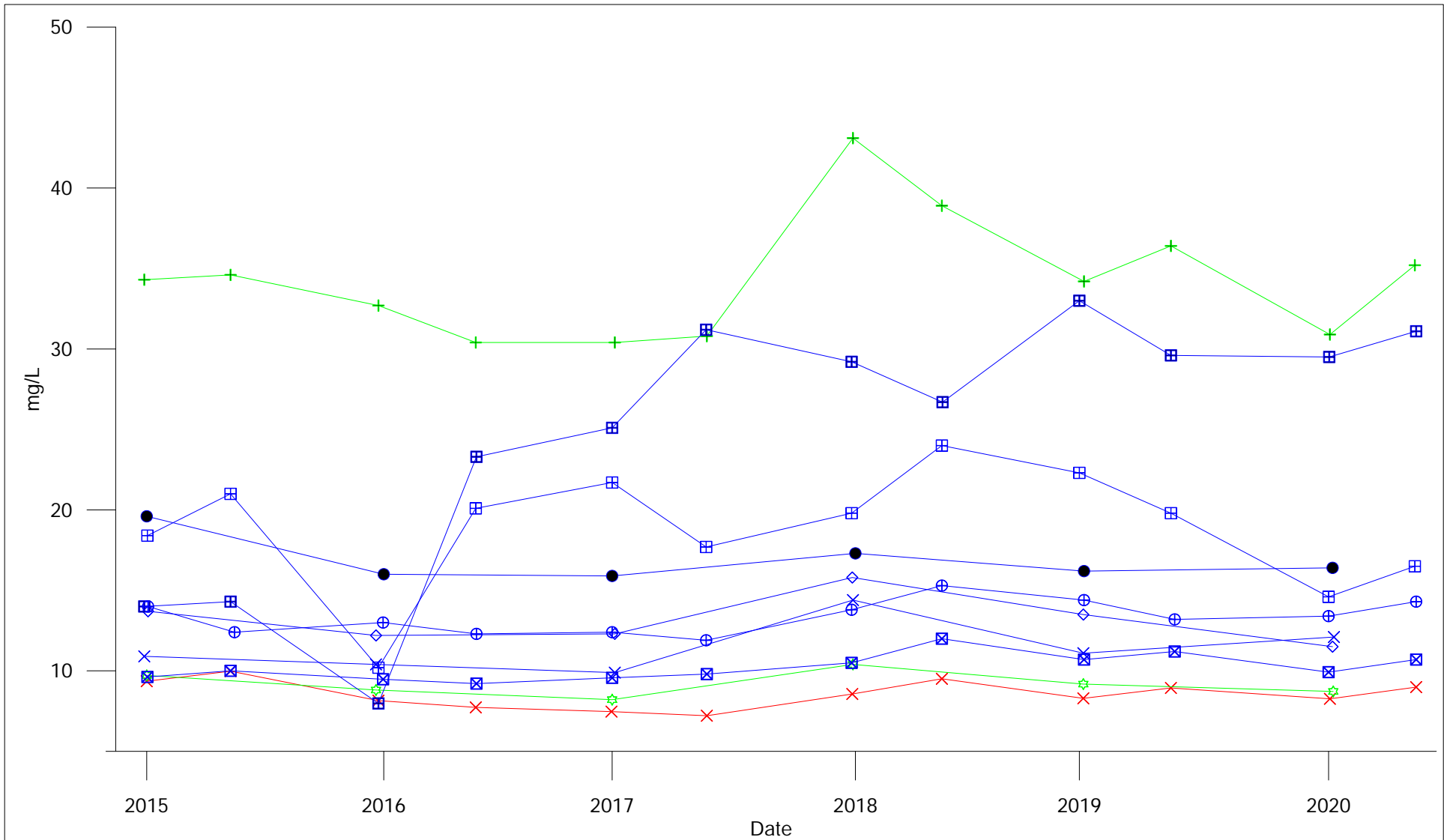

Up gradient
 X X X 6N60EER

Down gradient
 + + + 5N62E
 ☆ ☆ ☆ 6N67F

Cross gradient
 □ □ □ 13A
 ▣ ▣ ▣ 14A

Cross gradient
 ⊕ ⊕ ⊕ 15A
 ⊠ ⊠ ⊠ 16A
 ● ● ● 4N34DDR
 ◇ ◇ ◇ 6N57F
 X X X 6N63F



City of Winnipeg
 Solid Waste Services

BRADY ROAD RESOURCE MANAGEMENT FACILITY
**Dissolved Potassium
 Till Wells**
 APRIL 2021 | FIGURE 34 | REV 0

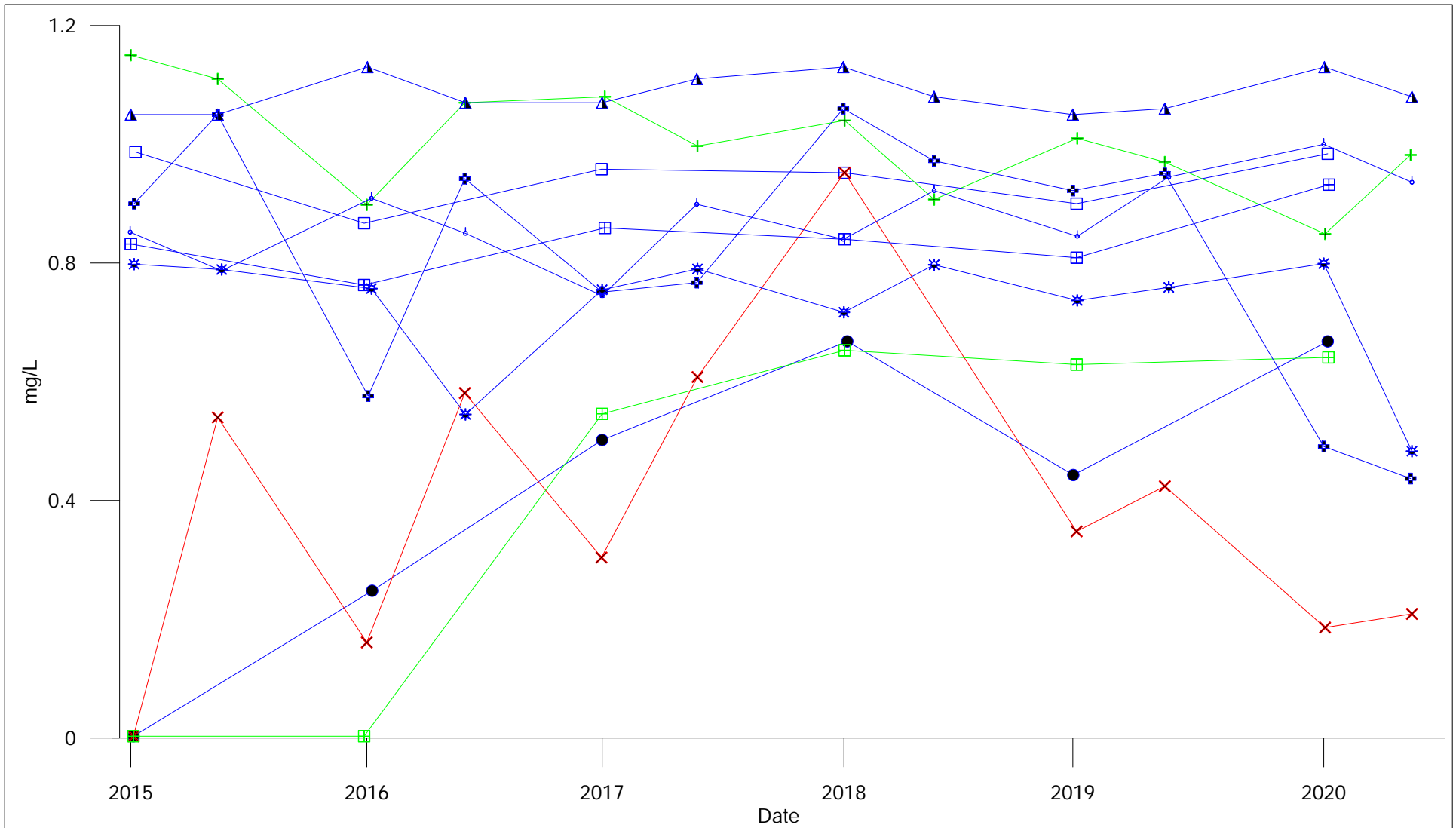

Up gradient
 X-X-X 6N60EER

Cross gradient
 + + + 13A
 ▲ ▲ ▲ 14A

Down gradient
 + + + 5N62E
 □ □ □ 6N67F

Cross gradient
 ○ ○ ○ 15A
 ☼ ☼ ☼ 16A
 ● ● ● 4N34DDR
 □ □ □ 6N57F
 □ □ □ 6N63F



City Of Winnipeg
 Solid Waste Services

BRADY ROAD RESOURCE MANAGEMENT FACILITY
**Total Ammonia
 Till Wells**
 APRIL 2021 | FIGURE 37 | REV 0

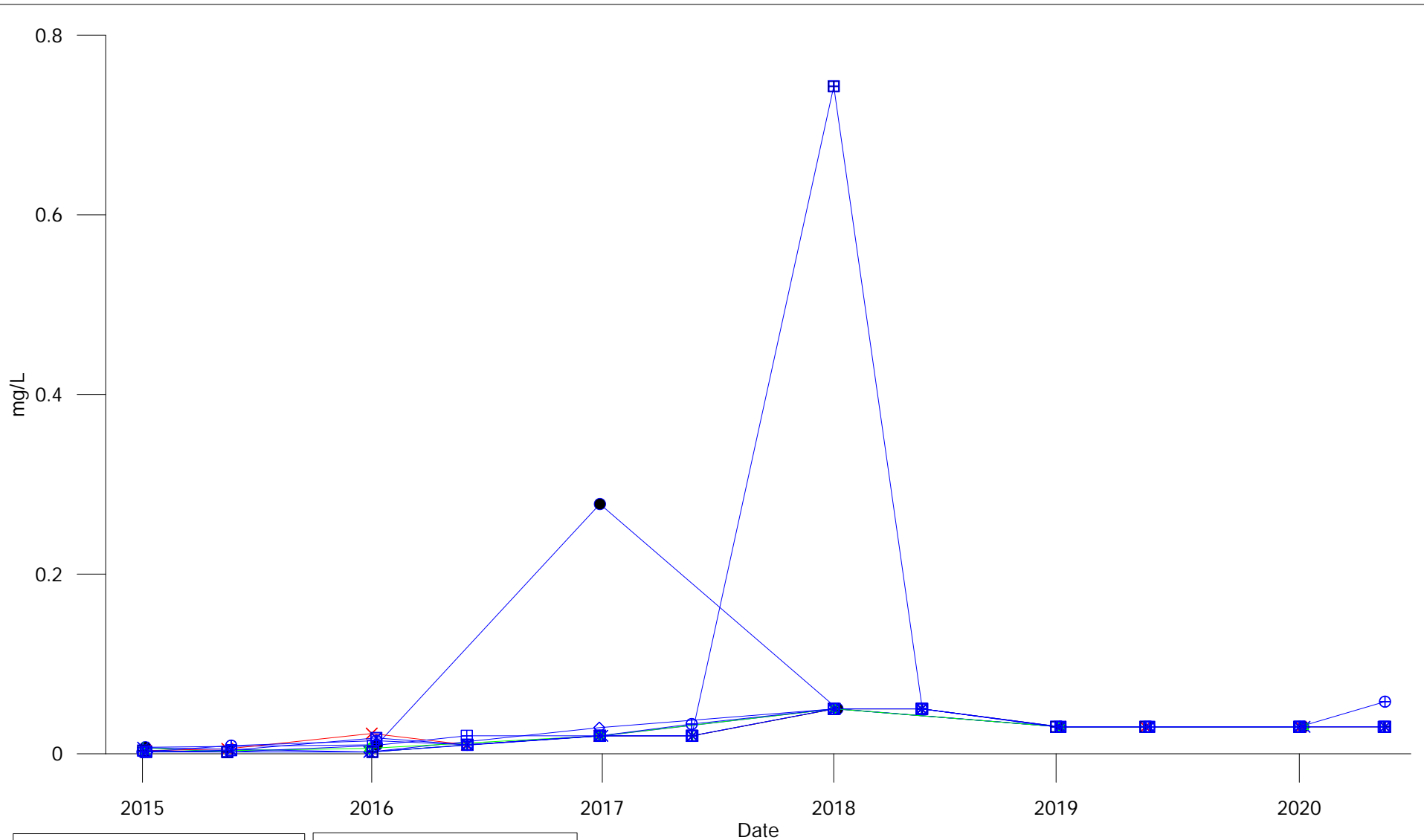

Up gradient
 X—X—X 6N60EER

Down gradient
 +—+—+ 5N62E
 ☆—☆—☆ 6N67F

Cross gradient
 □—□—□ 13A
 ⊠—⊠—⊠ 14A

Cross gradient
 ⊠—⊠—⊠ 16A
 ●—●—● 4N34DDR
 ◇—◇—◇ 6N57F
 ——* 6N63F
 ⊕—⊕—⊕ 15A



City Of Winnipeg
 Solid Waste Services

BRADY ROAD RESOURCE MANAGEMENT FACILITY

Phosphorus
 Till Wells

APRIL 2021

FIGURE 35

REV 0

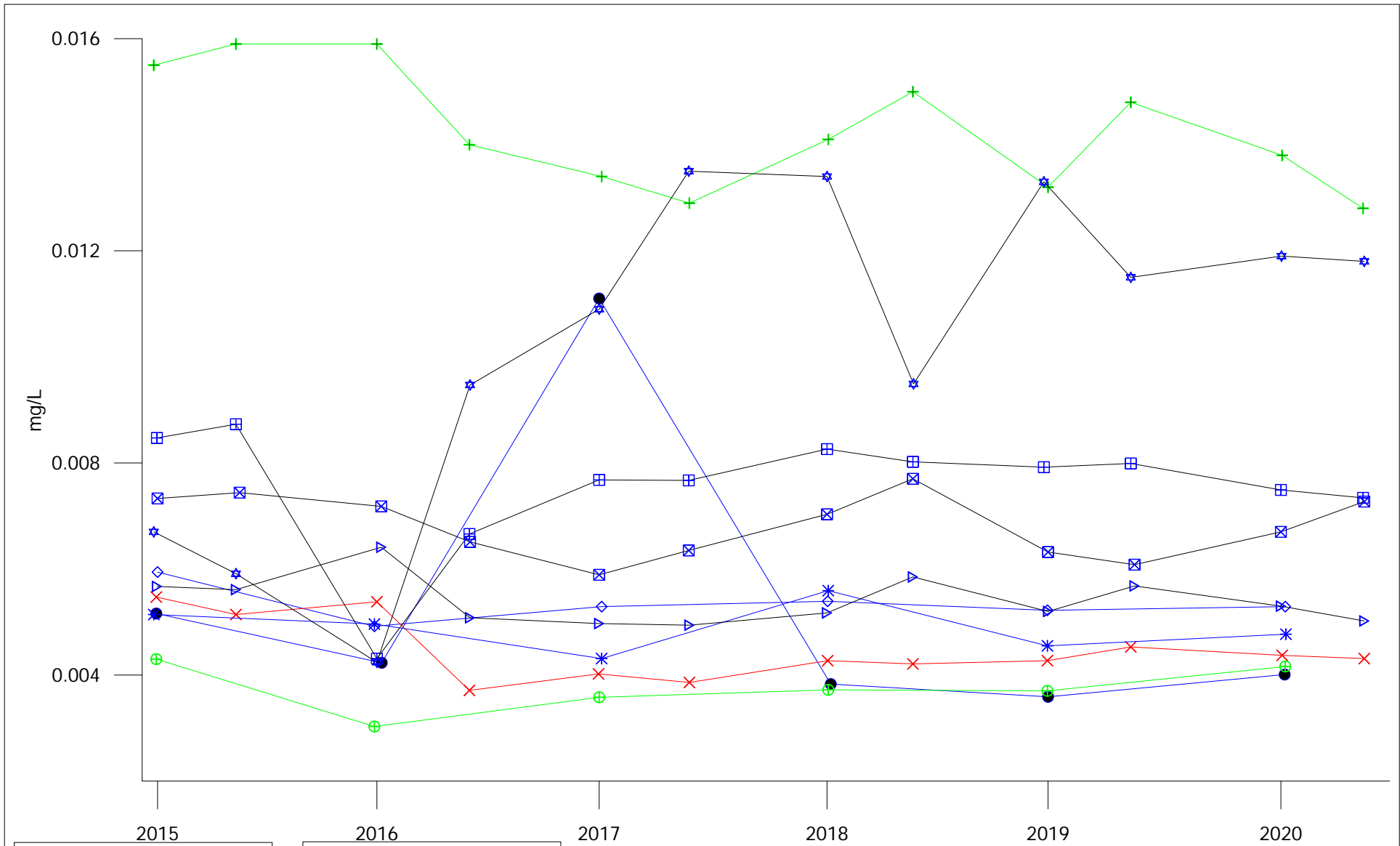

Up gradient
 X—X—X 6N60E

Down gradient
 +—+—+ 5N62E
 ⊕—⊕—⊕ 6N67F

Cross gradient
 ⊠—⊠—⊠ 15A
 ▽—▽—▽ 16A

Cross gradient
 ●—●—● 4N34DDR
 ◇—◇—◇ 6N57F
 ——* 6N63F
 ⊠—⊠—⊠ 13A
 ☆—☆—☆ 14A

	City Of Winnipeg Solid Waste Services	
	BRADY ROAD RESOURCE MANAGEMENT FACILITY	
Dissolved Rubidium Till Wells		
APRIL 2021	FIGURE 36	REV 0

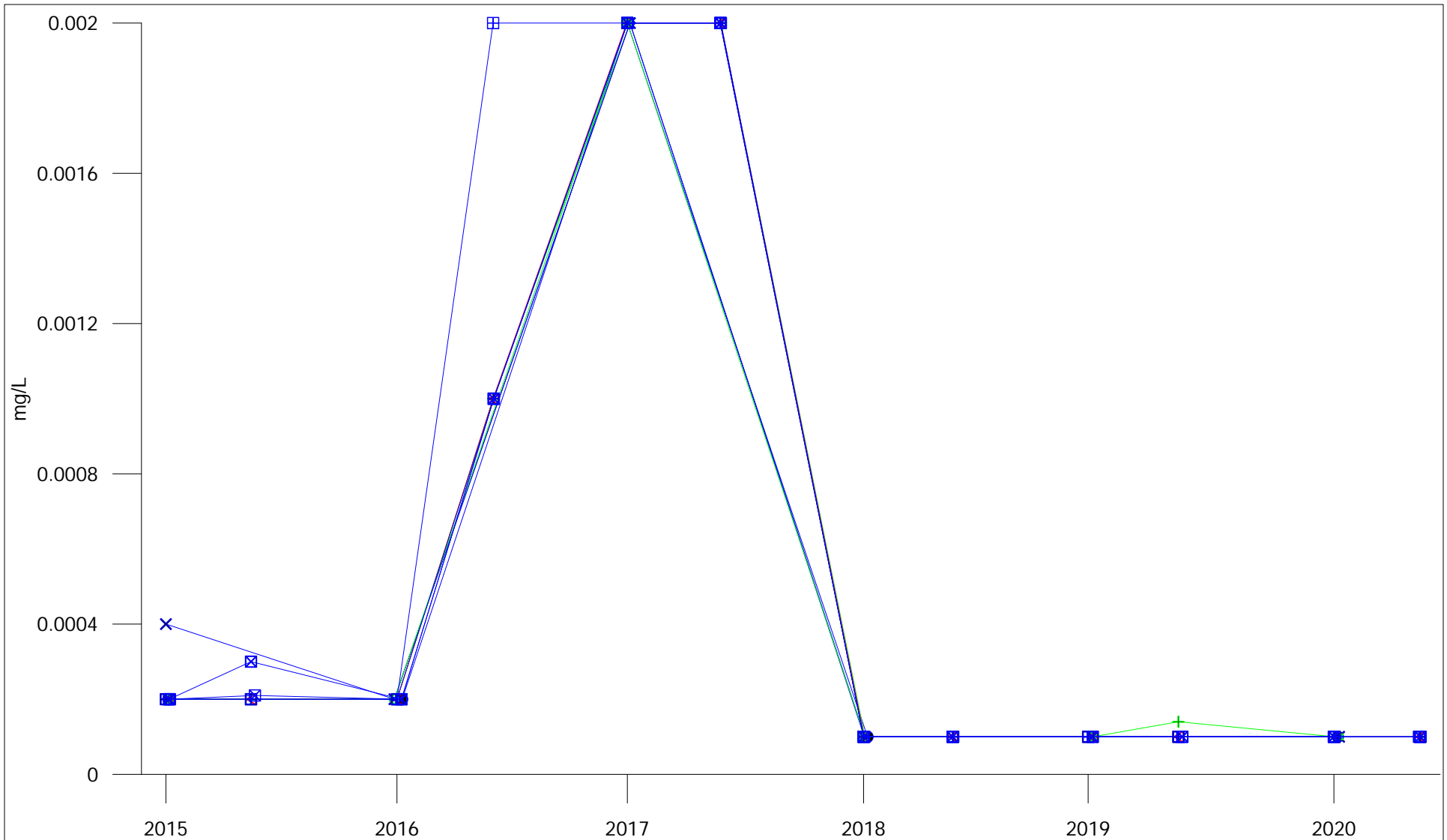

Up gradient
 6N60EER

Cross gradient
 4N34DDR
 6N57F
 6N63F
 13A
 14A

Down gradient
 5N62E
 6N67F

Cross gradient
 15A
 16A



City Of Winnipeg
 Solid Waste Services

BRADY ROAD RESOURCE MANAGEMENT FACILITY

Dissolved Tin
 Till Wells

APRIL 2021

FIGURE 38

REV 0

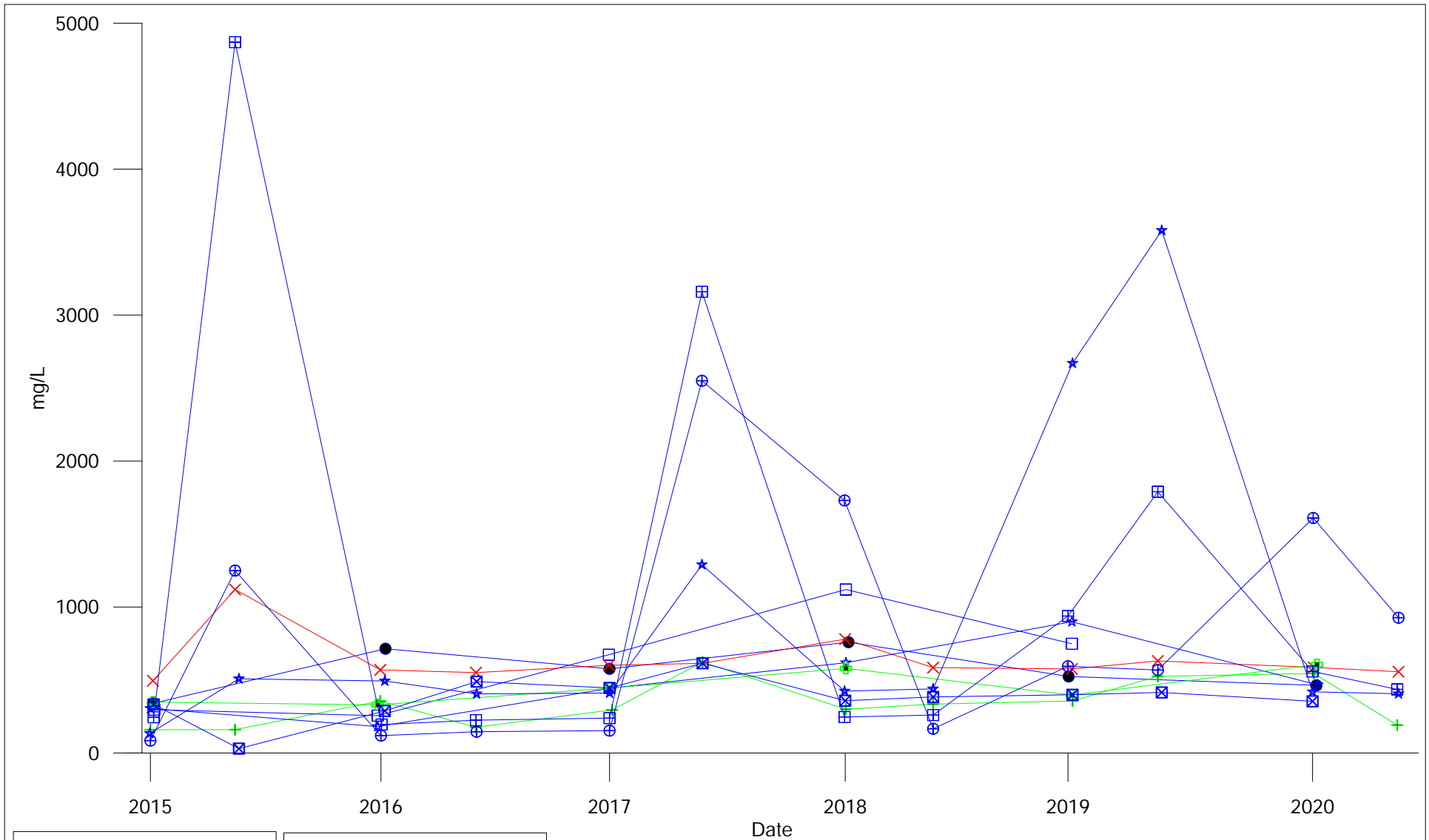

Up gradient
 X—X—X 6N60E

Down gradient
 +—+—+ 5N62E
 ⊕—⊕—⊕ 6N67F

Cross gradient
 ⊞—⊞—⊞ 13A
 ⊕—⊕—⊕ 14A

Cross gradient
 ☆—☆—☆ 15A
 ⊠—⊠—⊠ 16A
 ●—●—● 4N34DDR
 □—□—□ 6N57F
 ☆—☆—☆ 6N63F



City Of Winnipeg
 Solid Waste Services

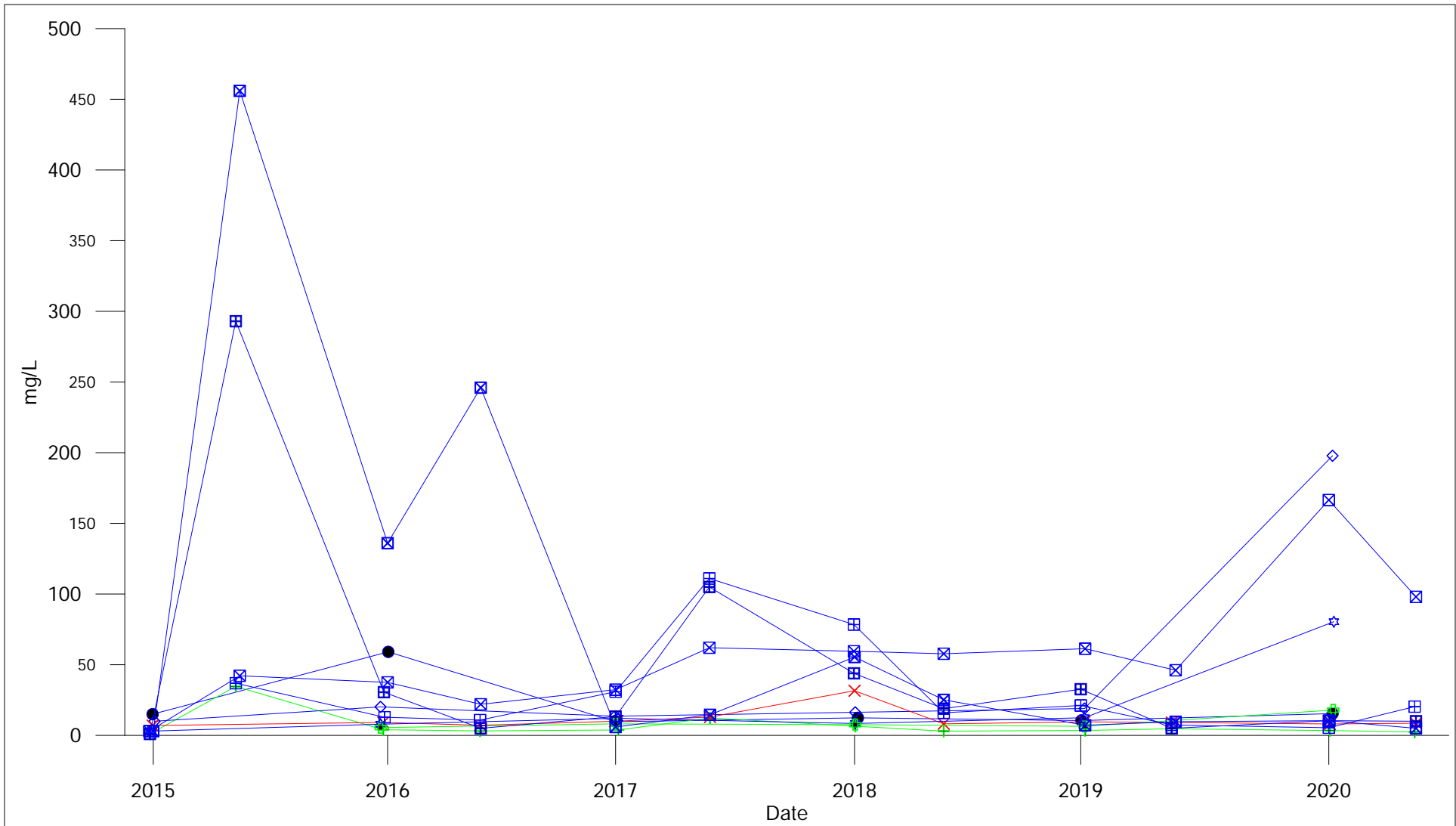

Up gradient

× × × 6N60E

Down gradient

+ + + 5N62E

■ ■ ■ 6N67F

Cross gradient

□ □ □ 13A

▣ ▣ ▣ 14A

Cross gradient

⊠ ⊠ ⊠ 15A

⊠ ⊠ ⊠ 16A

● ● ● 4N34DDR

◇ ◇ ◇ 6N57F

☆ ☆ ☆ 6N63F



City Of Winnipeg
Solid Waste Services

BRADY ROAD RESOURCE MANAGEMENT FACILITY

Total Organic Carbon
Till Wells

APRIL 2021 | FIGURE 39 | REV 0

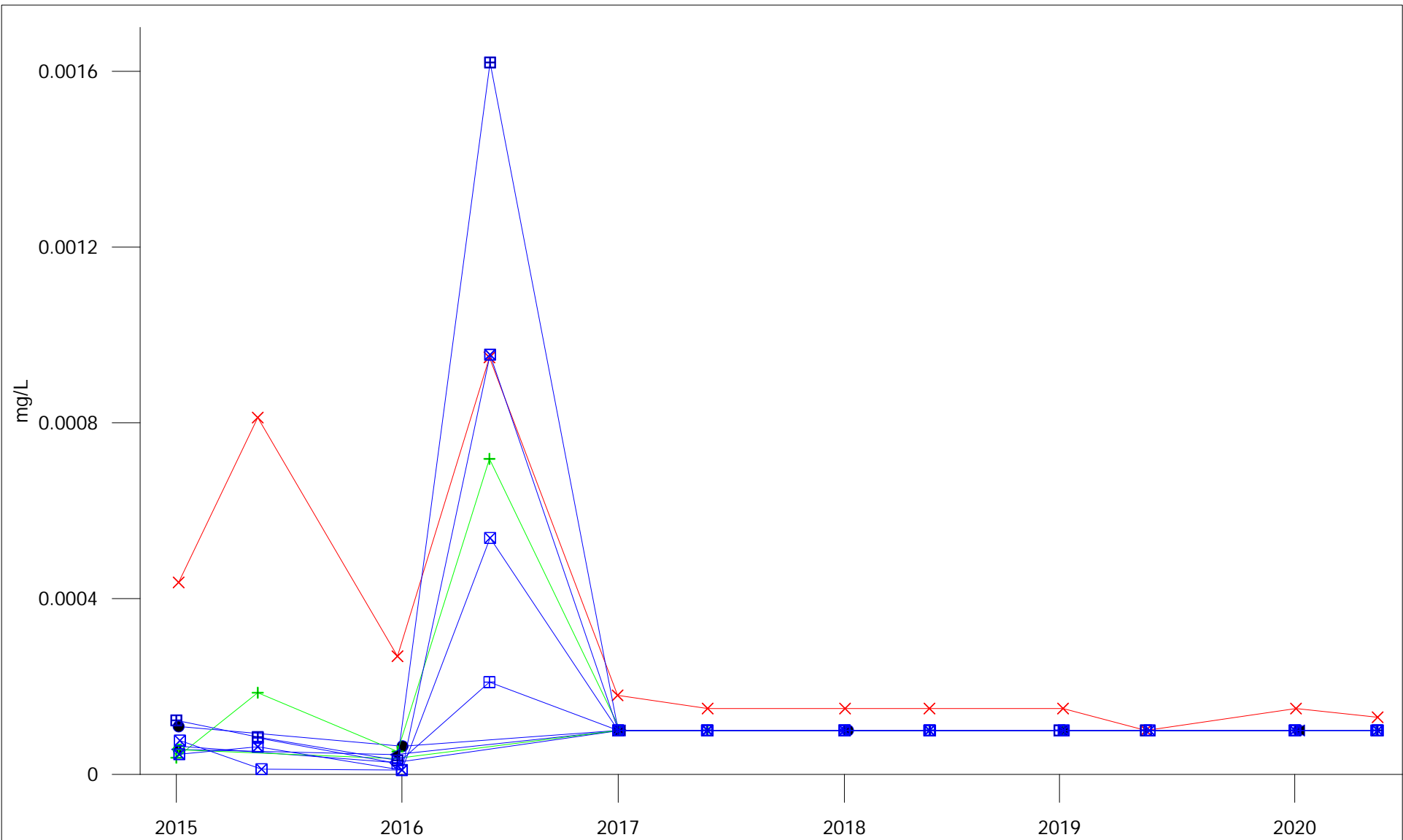

<p>Up gradient</p> <p>6N60E</p>	<p>Down gradient</p> <p>5N62E</p> <p>6N67F</p>	<p>Cross gradient</p> <p>4N34DDR</p> <p>6N57F</p> <p>6N63F</p> <p>13A</p> <p>14A</p>	<p>Cross gradient</p> <p>15A</p> <p>16A</p>	<p>City Of Winnipeg Solid Waste Services</p> <hr/> <p>BRADY ROAD RESOURCE MANAGEMENT FACILITY</p> <p>Dissolved Tungsten Till Wells</p> <table style="width: 100%; border: none;"> <tr> <td style="border: none;">APRIL 2021</td> <td style="border: none;">FIGURE 41</td> <td style="border: none;">REV 0</td> </tr> </table>	APRIL 2021	FIGURE 41	REV 0
APRIL 2021	FIGURE 41	REV 0					

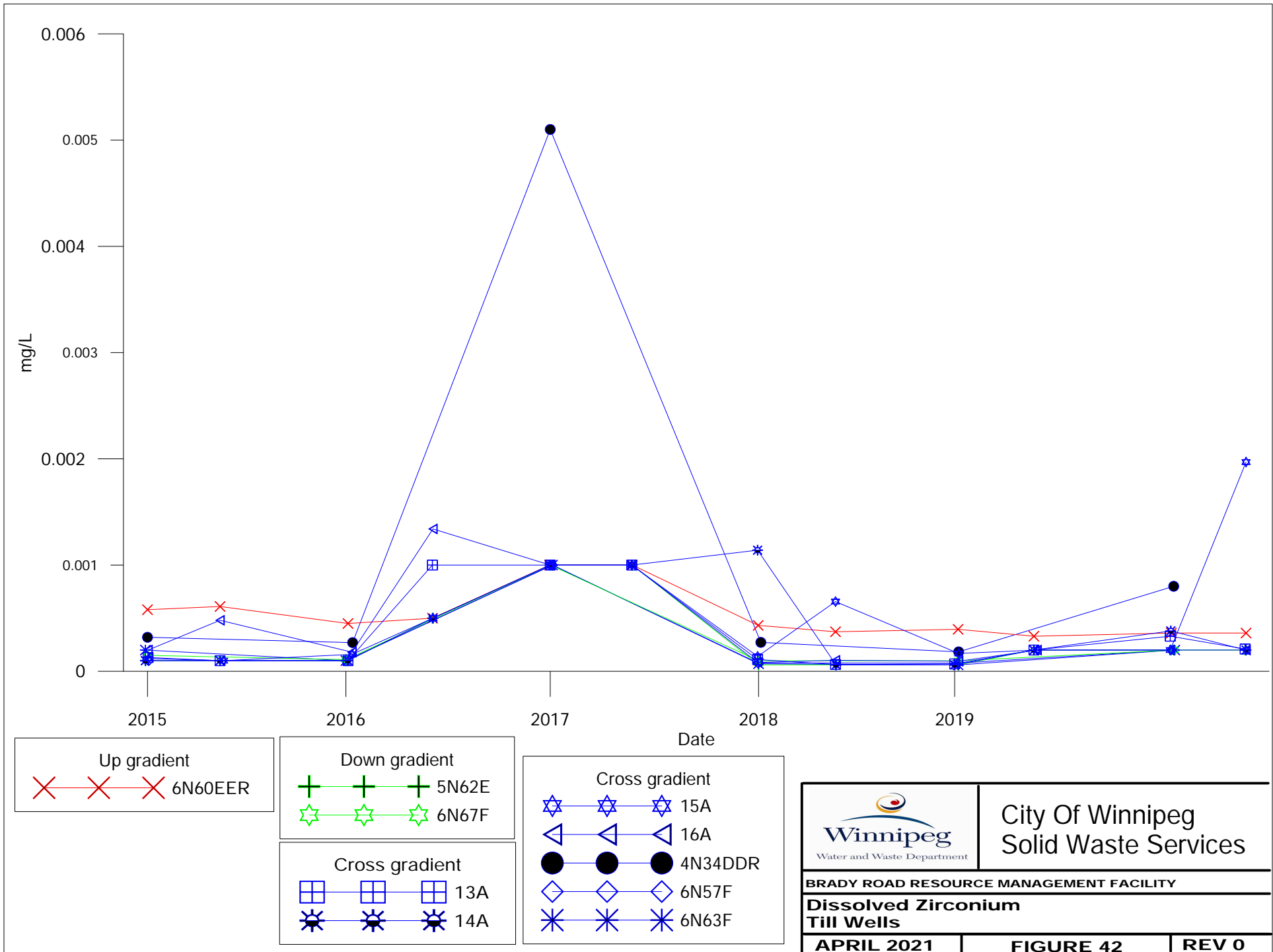

City Of Winnipeg
Solid Waste Services

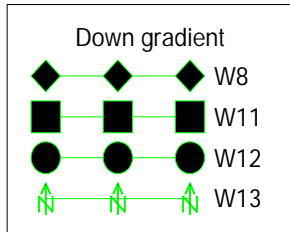
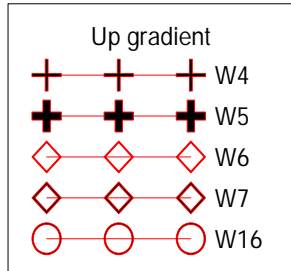
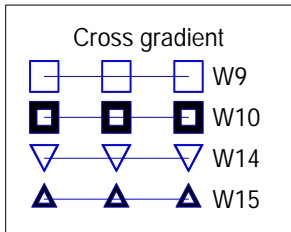
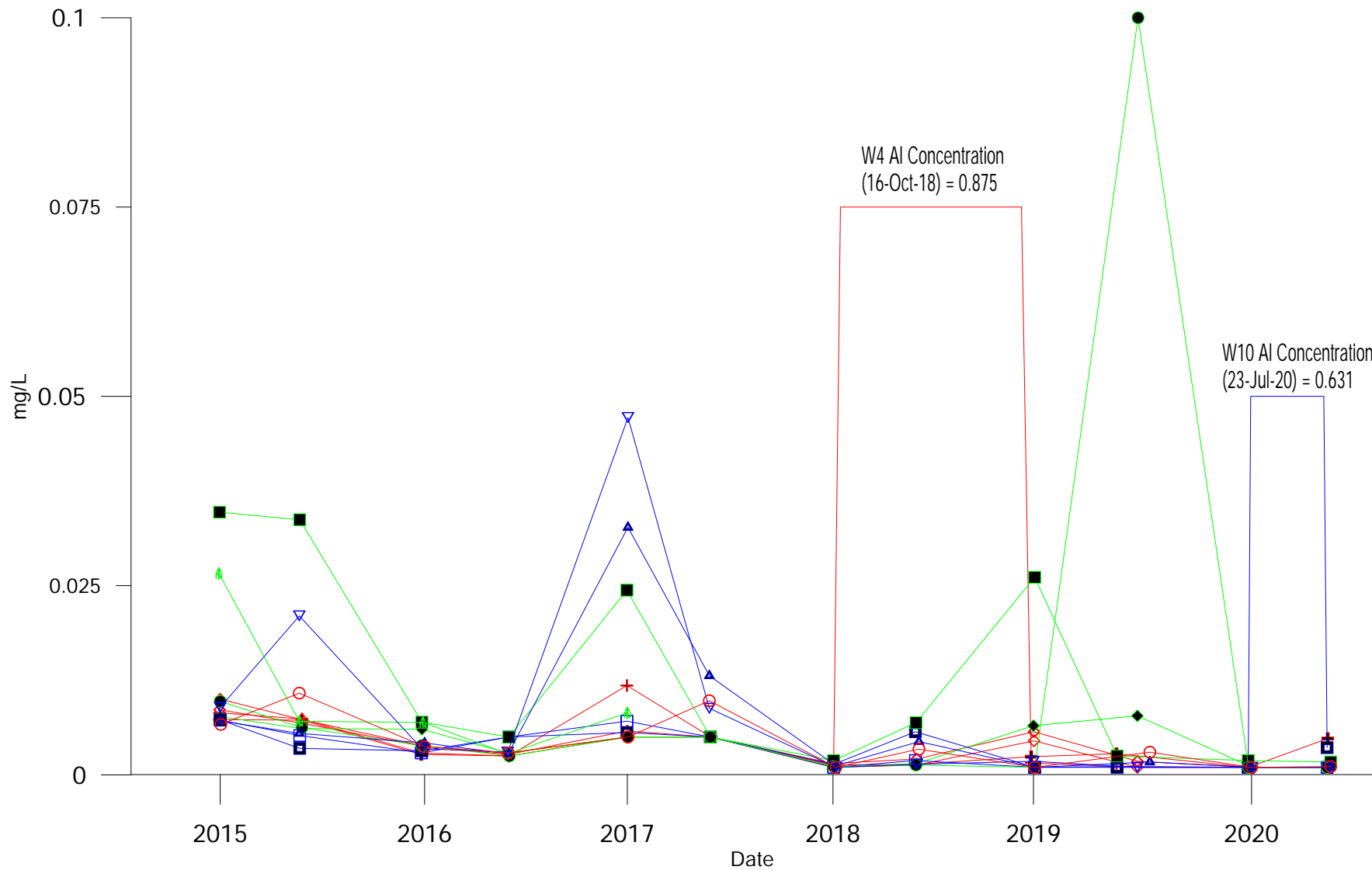

	City Of Winnipeg Solid Waste Services	
	BRADY ROAD RESOURCE MANAGEMENT FACILITY	
Dissolved Aluminium Concentration Bedrock Wells		
APRIL 2021	FIGURE 1	REV 0

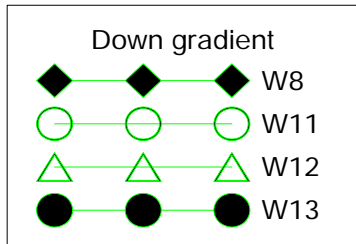
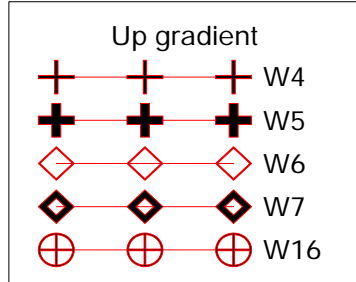
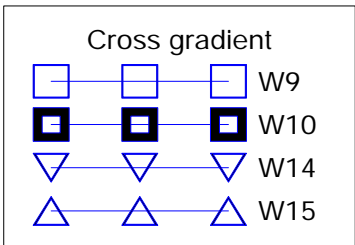
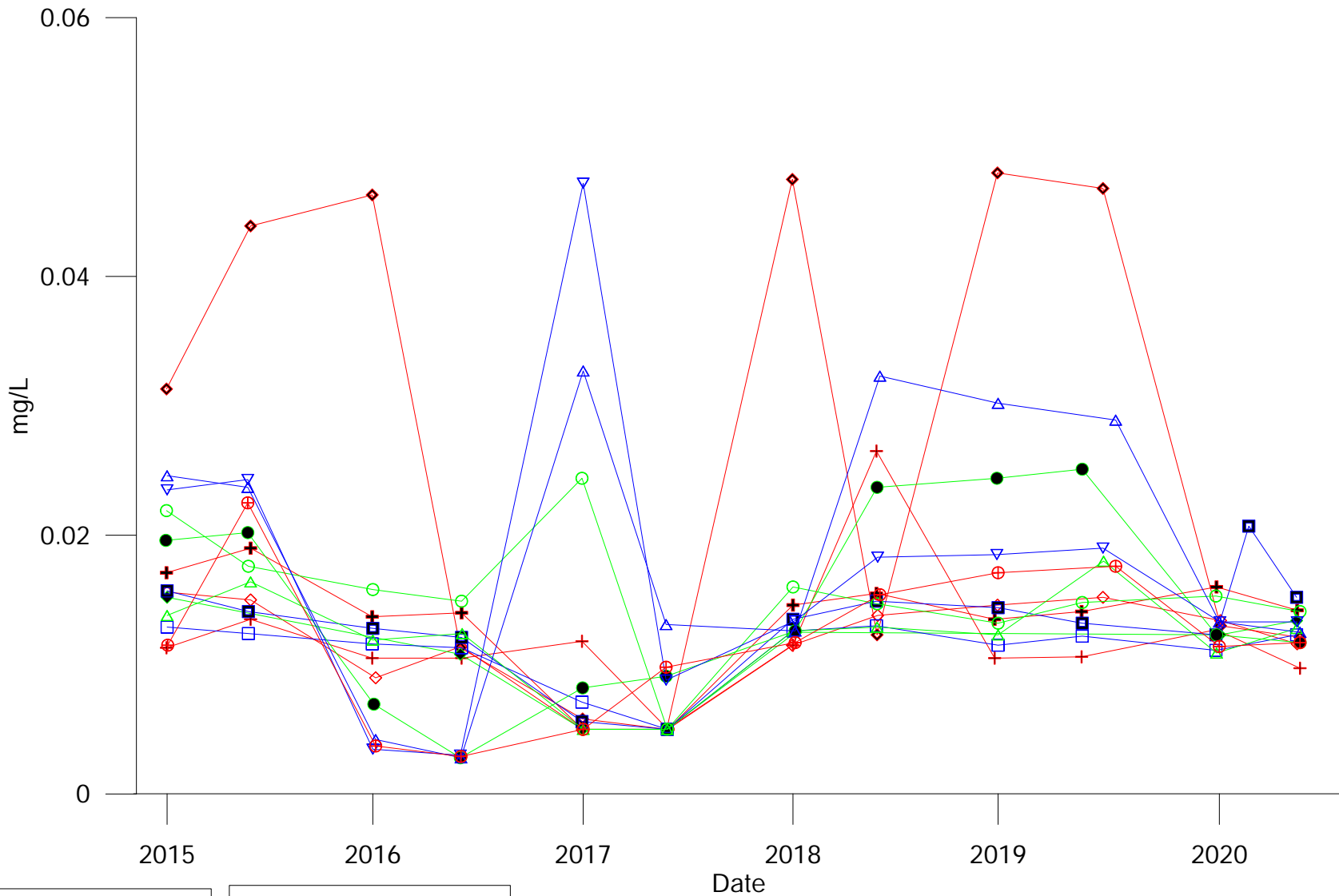

Barium MOE Criteria = 29 mg/L

	City of Winnipeg Solid Waste Services	
	BRADY ROAD RESOURCE MANAGEMENT FACILITY	
Dissolved Barium Concentration Bedrock Wells		
APRIL 2021	FIGURE 2	REV 0

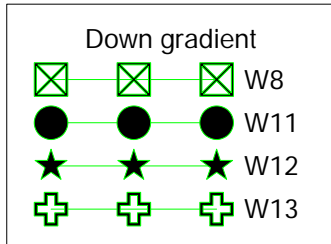
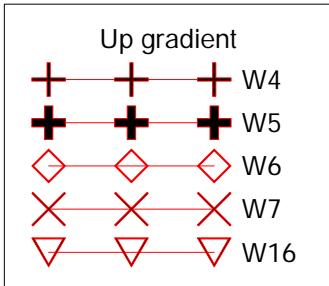
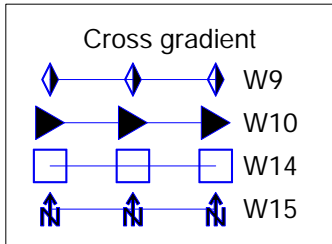
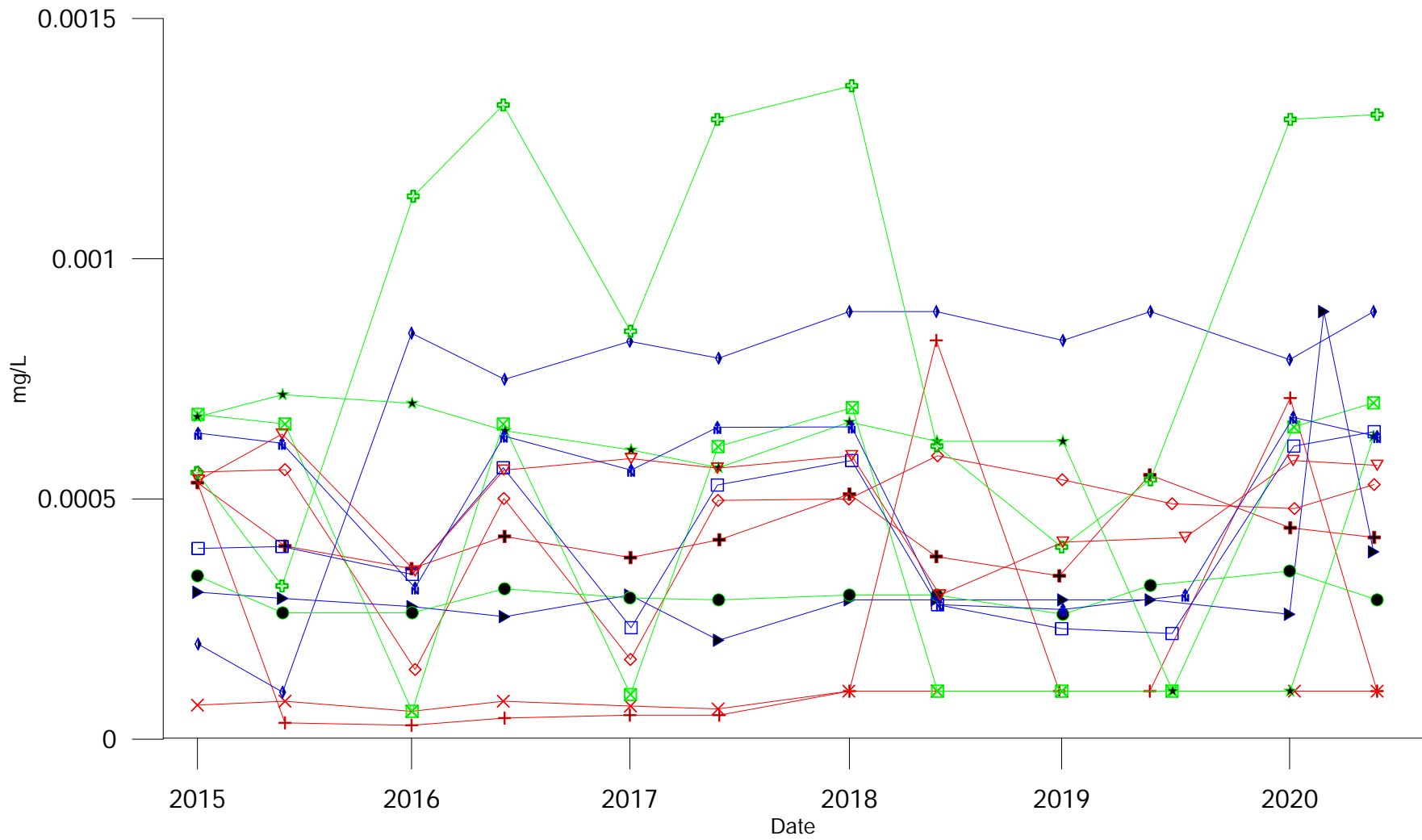

MOE Cobalt Criteria = 0.066 mg/L

	City Of Winnipeg Solid Waste Services	
	BRADY ROAD RESOURCE MANAGEMENT FACILITY	
Dissolved Cobalt Concentration Bedrock Wells		
APRIL 2021	FIGURE 3	REV 0

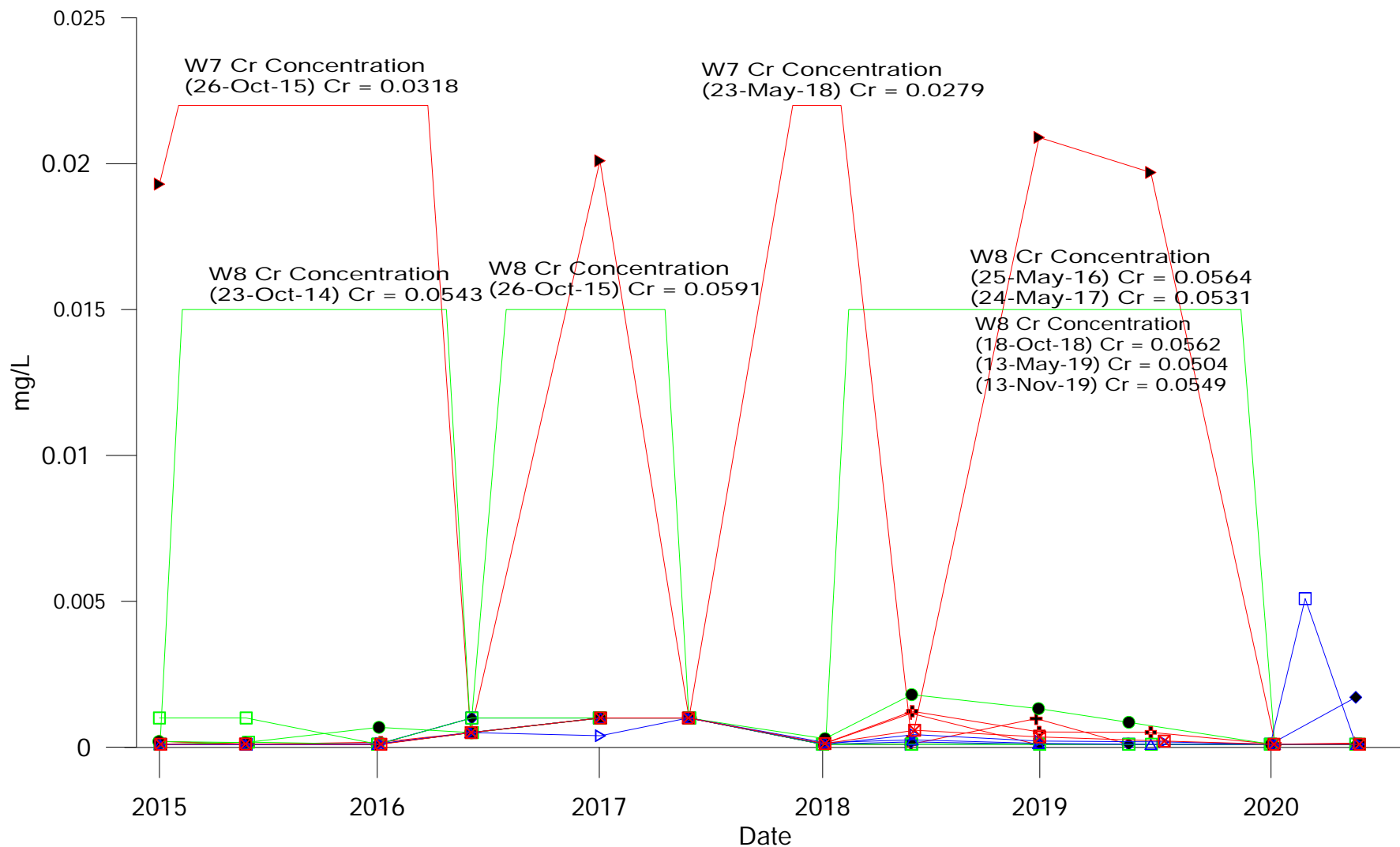

Chromium MOE Criteria = 0.81 mg/L

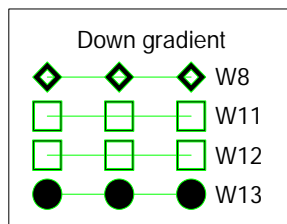
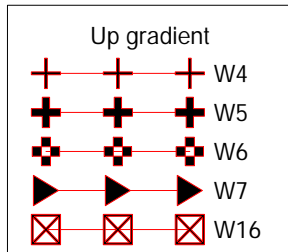
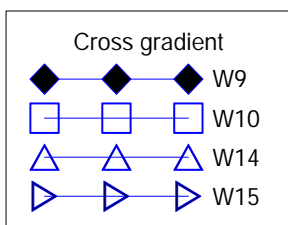

	City Of Winnipeg Solid Waste Services	
	BRADY ROAD RESOURCE MANAGEMENT FACILITY	
Dissolved Chromium Concentration Bedrock Wells		
APRIL 2021	FIGURE 4	REV 0

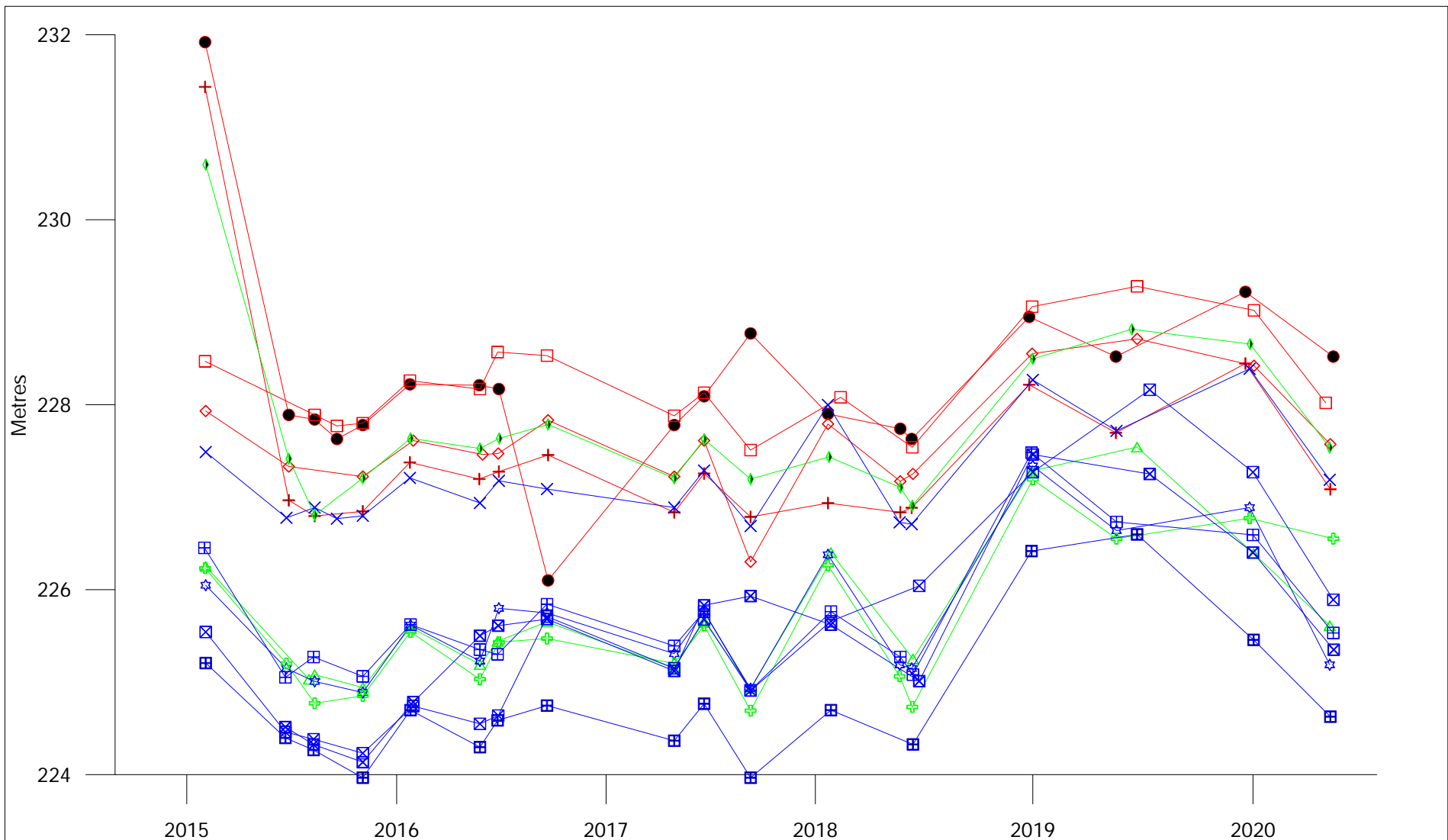

Cross gradient

□	□	□	W13
⊕	⊕	⊕	W14
⊗	⊗	⊗	W15
⊠	⊠	⊠	W16

Cross gradient

☆	☆	☆	W10
×	×	×	W9

Up gradient

+	+	+	W11
◇	◇	◇	W12
△	△	△	W8

Down gradient

●	●	●	W4
+	+	+	W5
◇	◇	◇	W6
□	□	□	W7

	City of Winnipeg Solid Waste Services
	BRADY ROAD RESOURCE MANAGEMENT FACILITY
GROUNDWATER ELEVATION Bedrock Wells	
APRIL 2021	FIGURE GW-2 REV 0

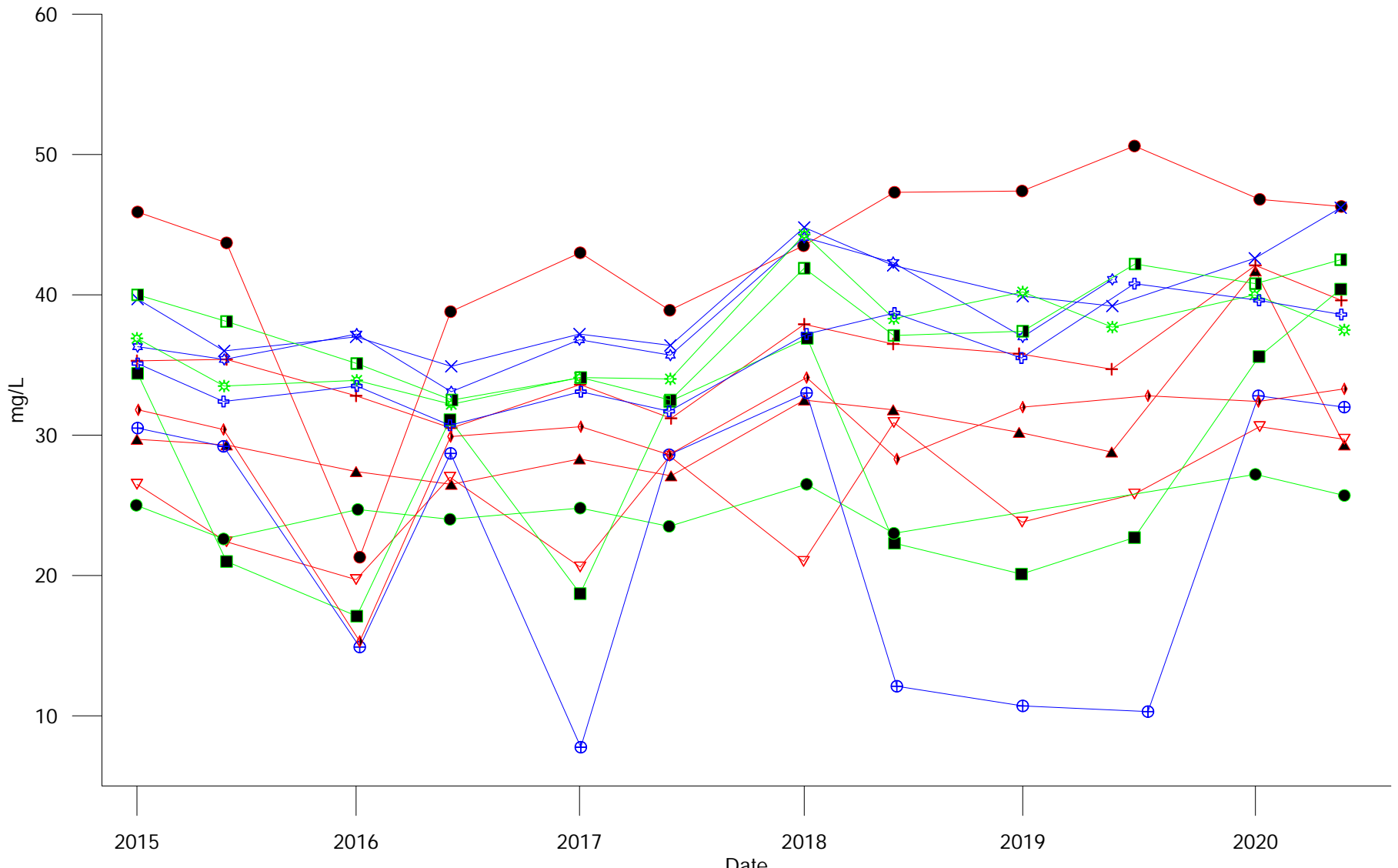

Cross gradient

- W9
- W10
- W14
- W15

Up gradient

- W4
- W5
- W6
- W7
- W16

Down gradient

- W8
- W11
- W12
- W13

	City Of Winnipeg Solid Waste Services	
	BRADY ROAD RESOURCE MANAGEMENT FACILITY	
Dissolved Potassium Concentration Bedrock Wells		
APRIL 2021	FIGURE 5	REV 0

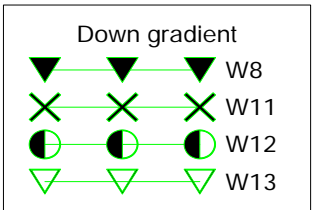
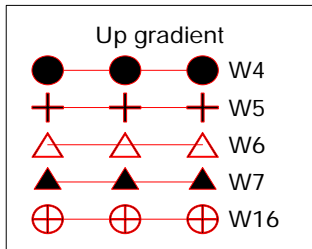
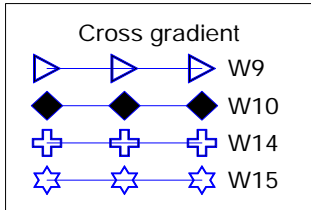
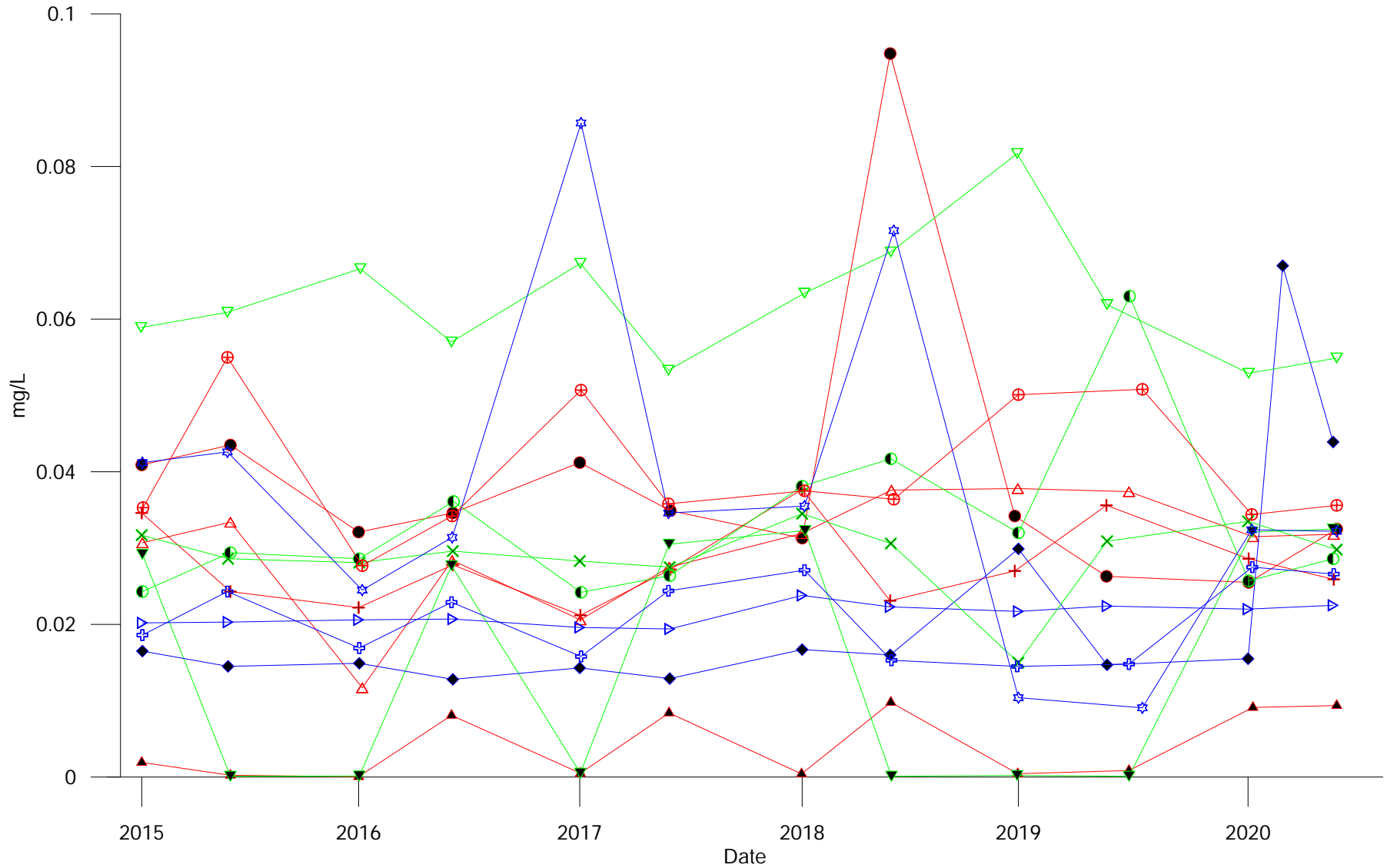

City Of Winnipeg
Solid Waste Services

BRADY ROAD RESOURCE MANAGEMENT FACILITY

Dissolved Manganese Concentration
Bedrock Wells

APRIL 2021

FIGURE 7

REV 0

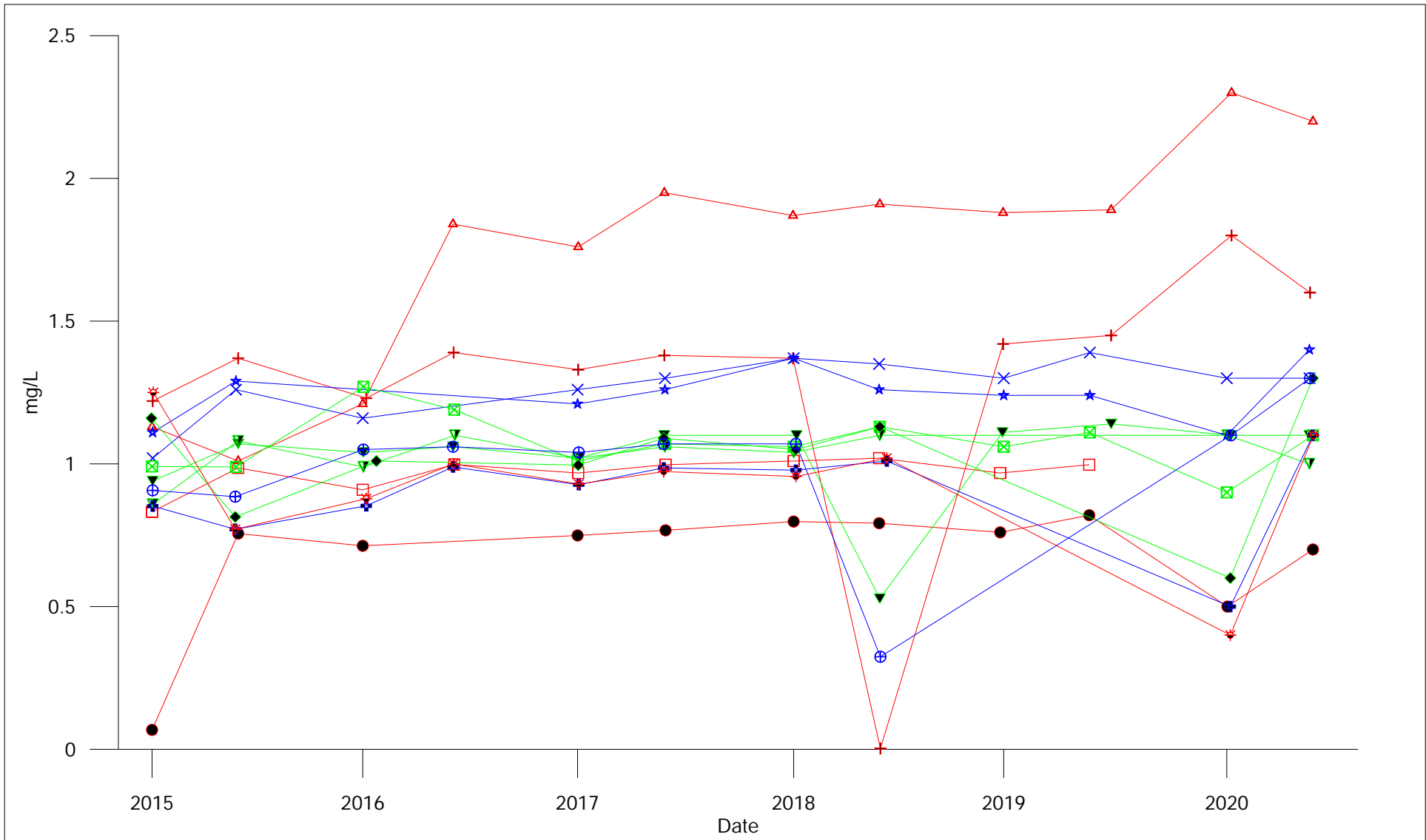

Cross gradient

- × × × W9
- ★ ★ ★ W10
- ⊕ ⊕ ⊕ W14
- ⊕ ⊕ ⊕ W15

Up gradient

- ● ● W4
- □ □ W5
- + + + W6
- △ △ △ W7
- ⊙ ⊙ ⊙ W16

Down gradient

- ▼ ▼ ▼ W8
- ⊠ ⊠ ⊠ W11
- ▼ ▼ ▼ W12
- ◆ ◆ ◆ W13



City Of Winnipeg
Solid Waste Services

BRADY ROAD RESOURCE MANAGEMENT FACILITY

**Ammonia Concentration
Bedrock Wells**

APRIL 2021

FIGURE 8

REV 0

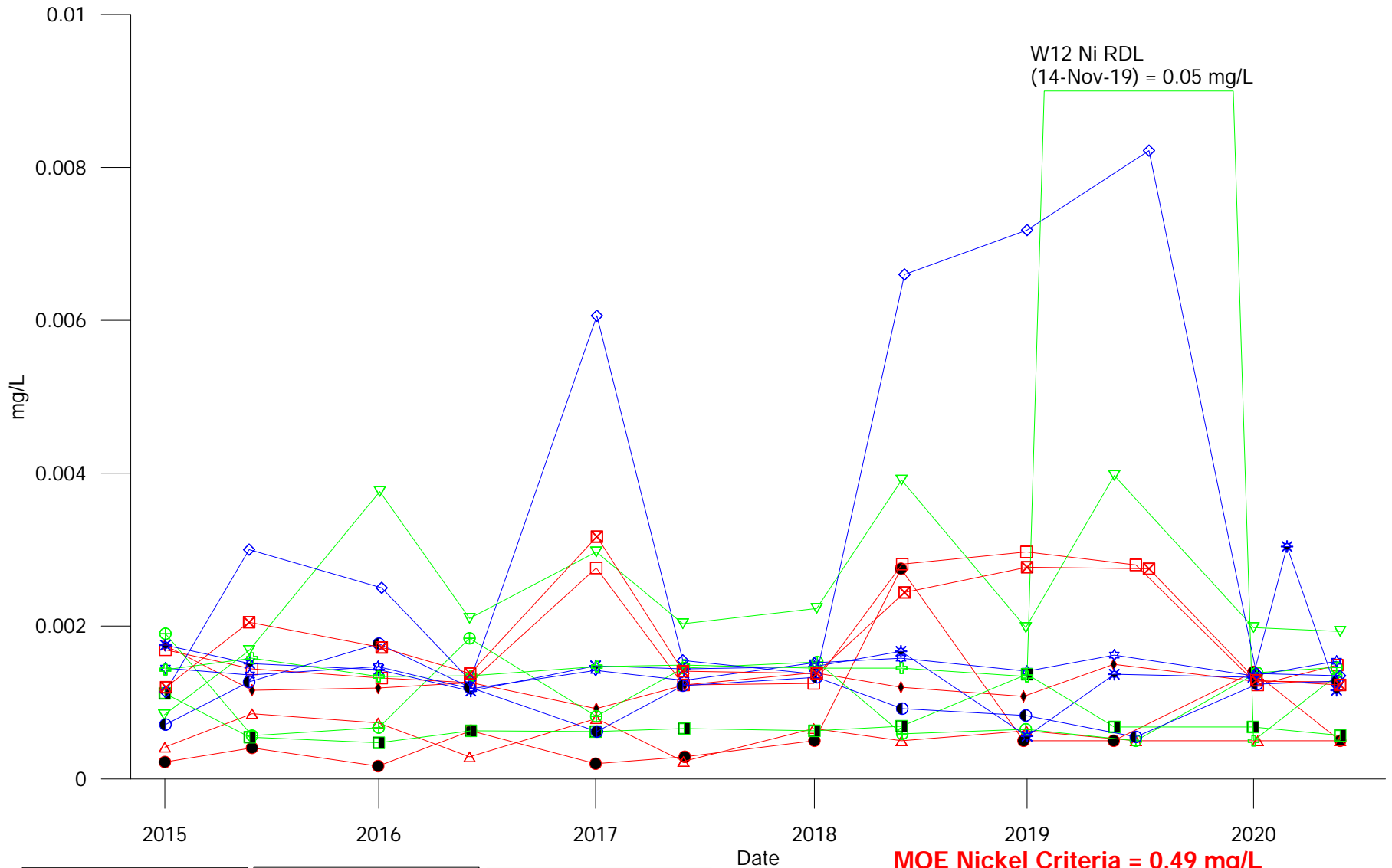

W12 Ni RDL
(14-Nov-19) = 0.05 mg/L

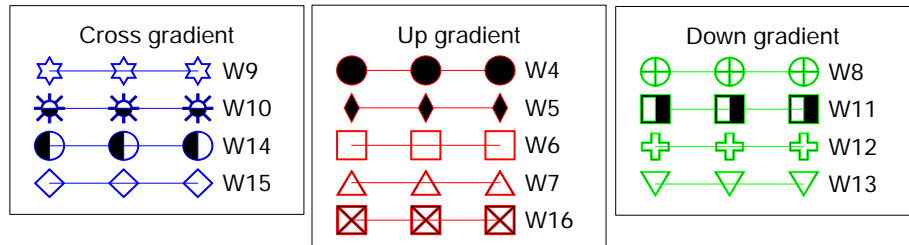

MOE Nickel Criteria = 0.49 mg/L

	City Of Winnipeg Solid Waste Services	
	BRADY ROAD RESOURCE MANAGEMENT FACILITY	
Dissolved Nickel Concentration Bedrock Wells		
APRIL 2021	FIGURE 9	REV 0

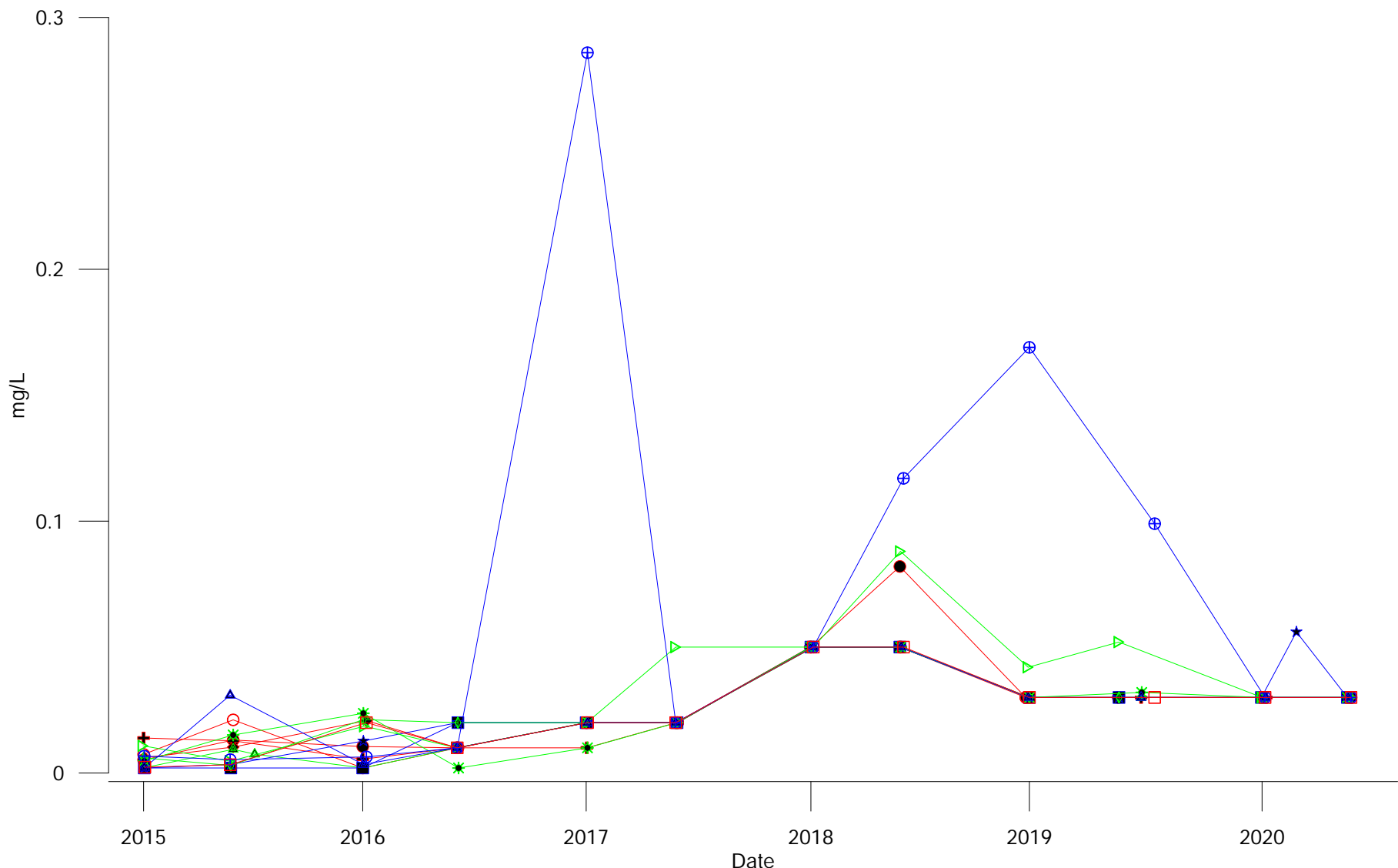

Date

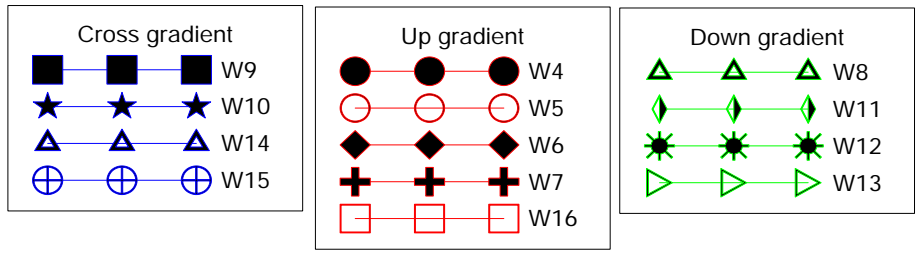

	City Of Winnipeg Solid Waste Services	
	BRADY ROAD RESOURCE MANAGEMENT FACILITY	
Phosphorus Concentration Bedrock Wells		
APRIL 2021	FIGURE 10	REV 0

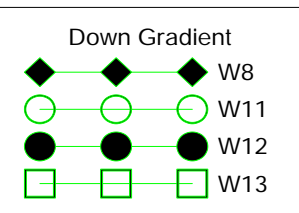
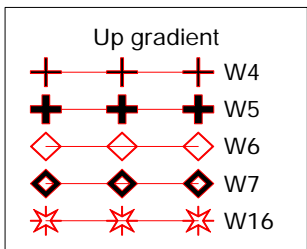
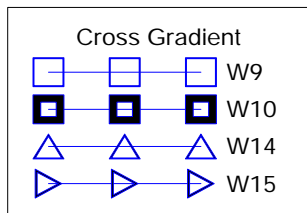
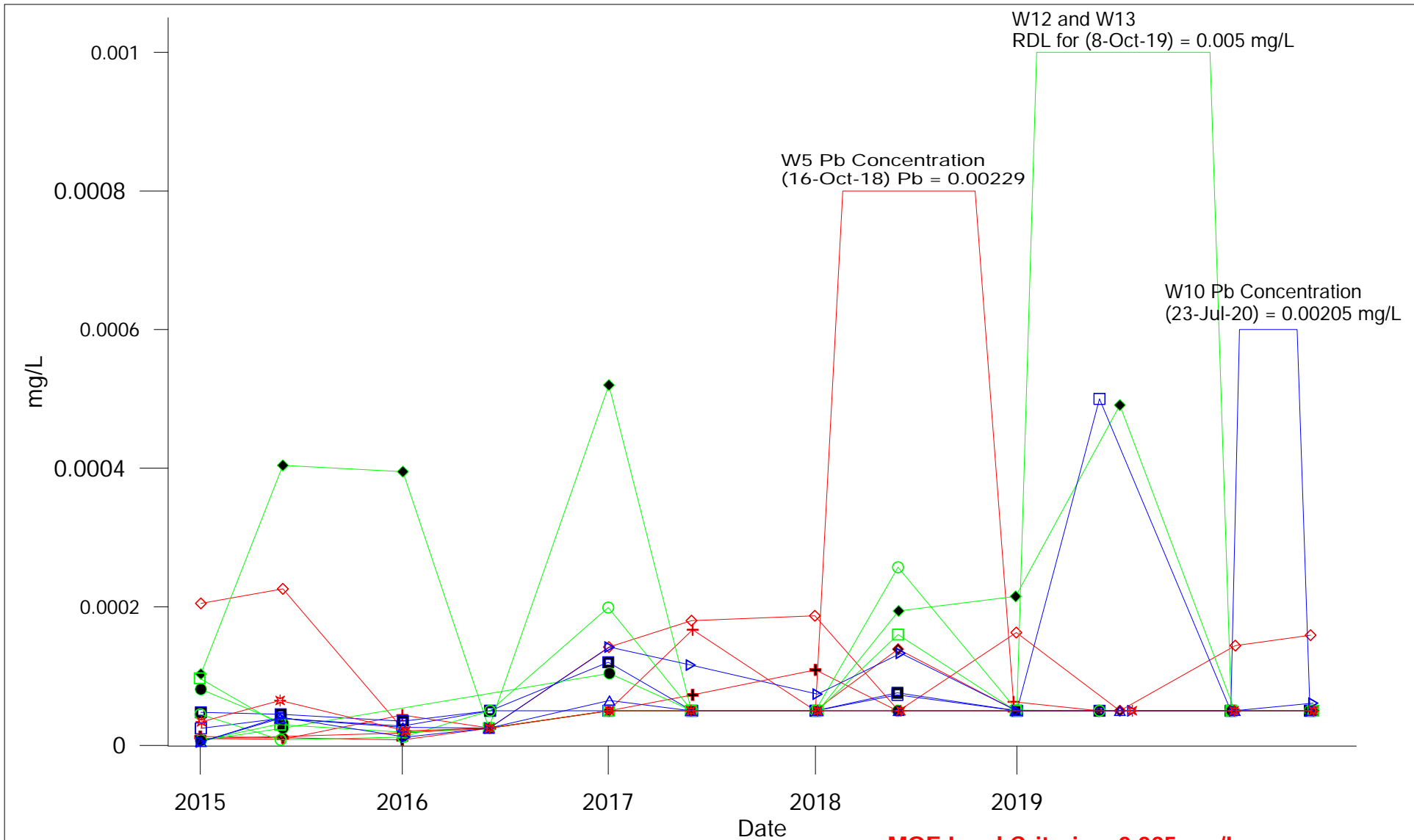

MOE Lead Criteria = 0.025 mg/L

		City Of Winnipeg Solid Waste Services	
BRADY ROAD RESOURCE MANAGEMENT FACILITY			
Dissolved Lead Concentration Bedrock Wells			
APRIL 2021	FIGURE 6	REV 0	

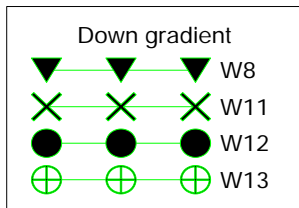
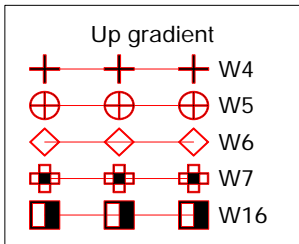
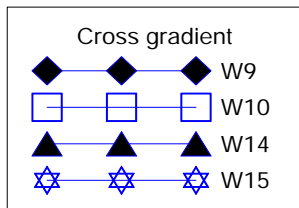
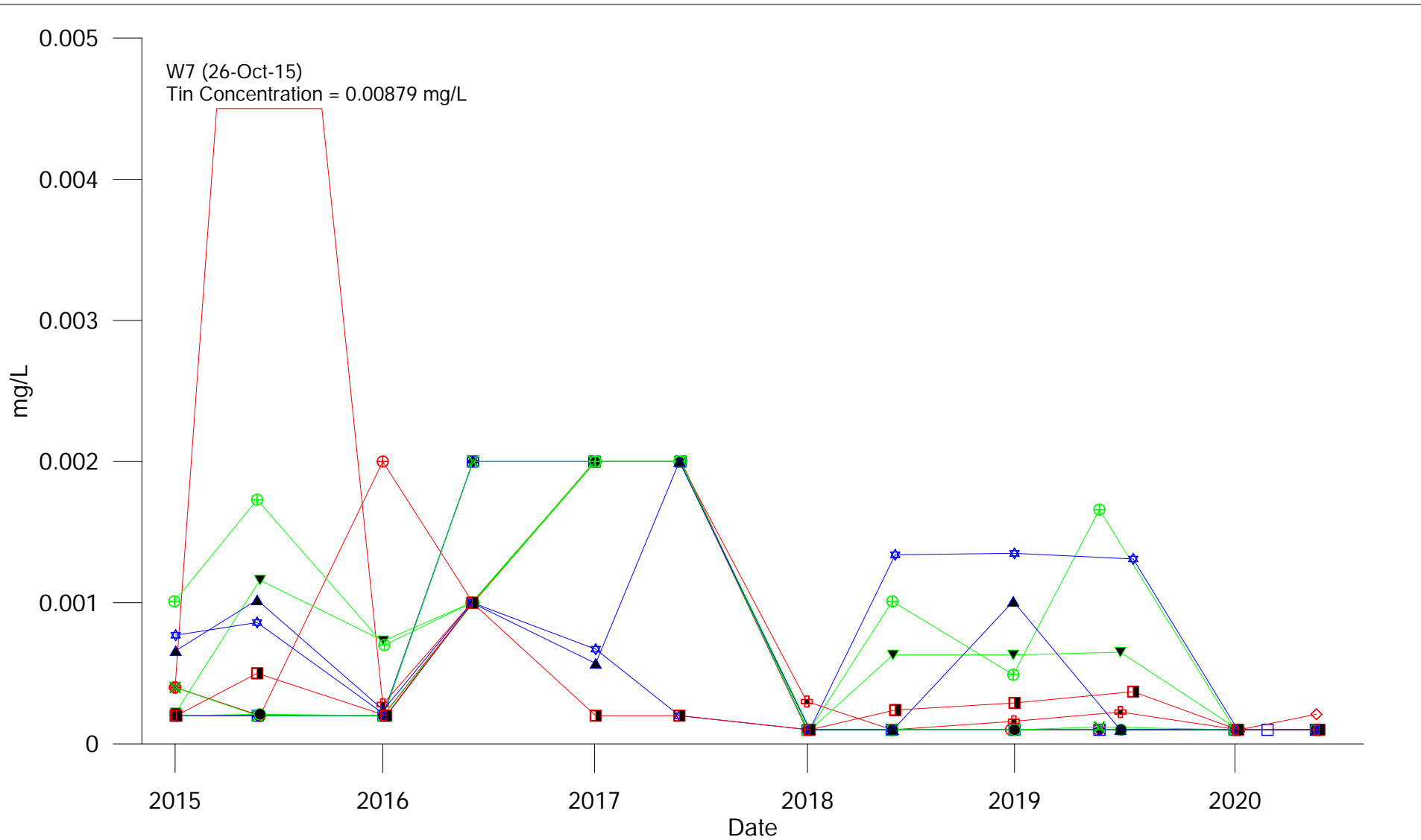

		City Of Winnipeg Solid Waste Services	
BRADY ROAD RESOURCE MANAGEMENT FACILITY			
Dissolved Tin Concentration Bedrock Wells			
APRIL 2021	FIGURE 11	REV 0	

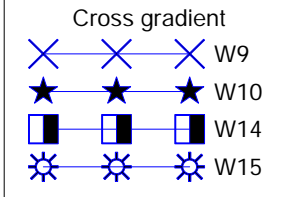
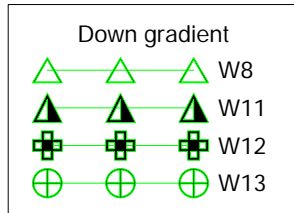
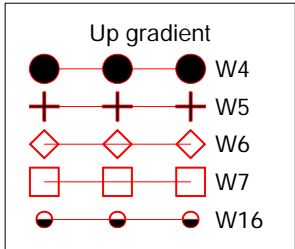
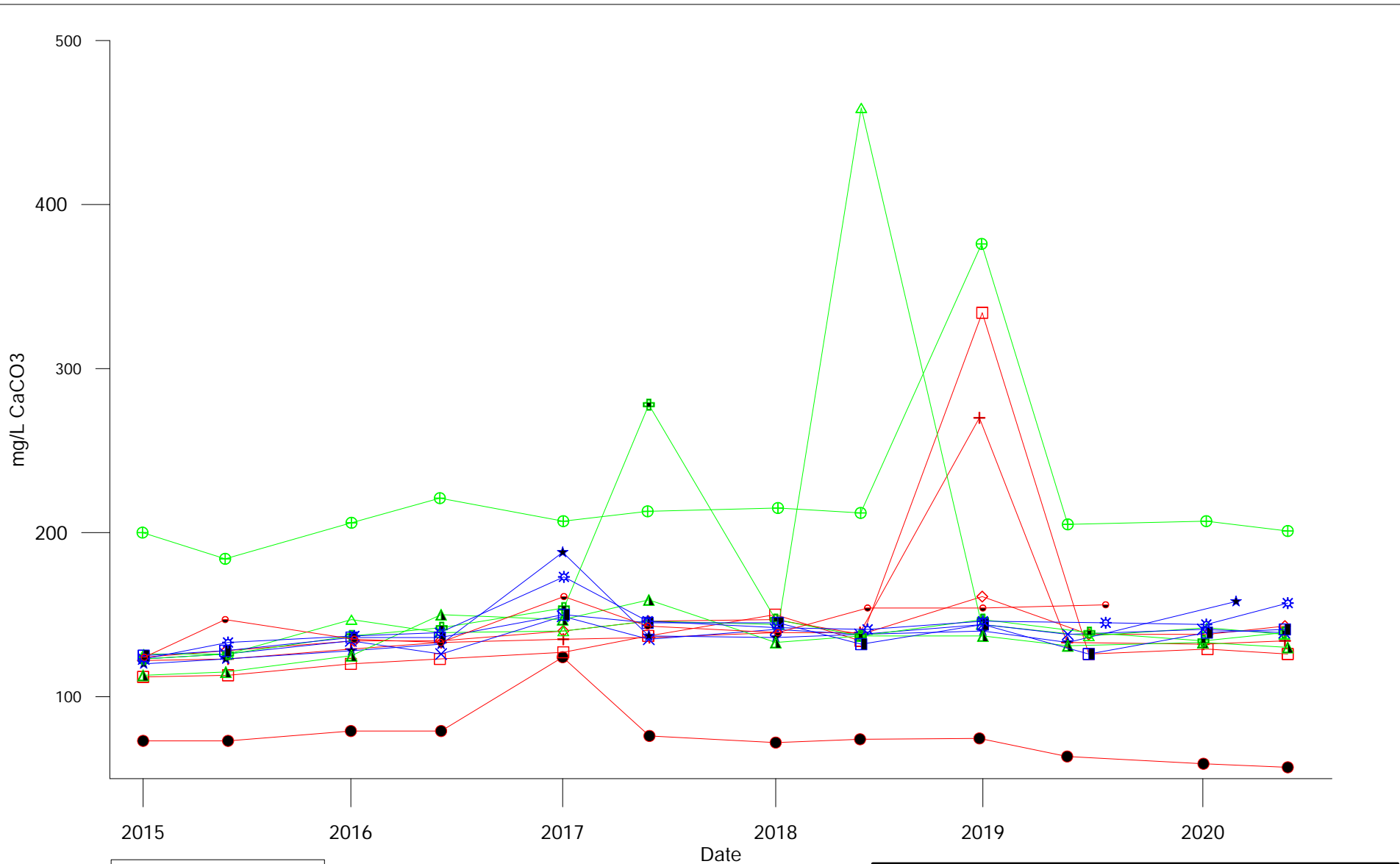

	City Of Winnipeg Solid Waste Services	
	BRADY ROAD RESOURCE MANAGEMENT FACILITY	
Total Alkalinity Bedrock Wells		
APRIL 2021	FIGURE 12	REV 0

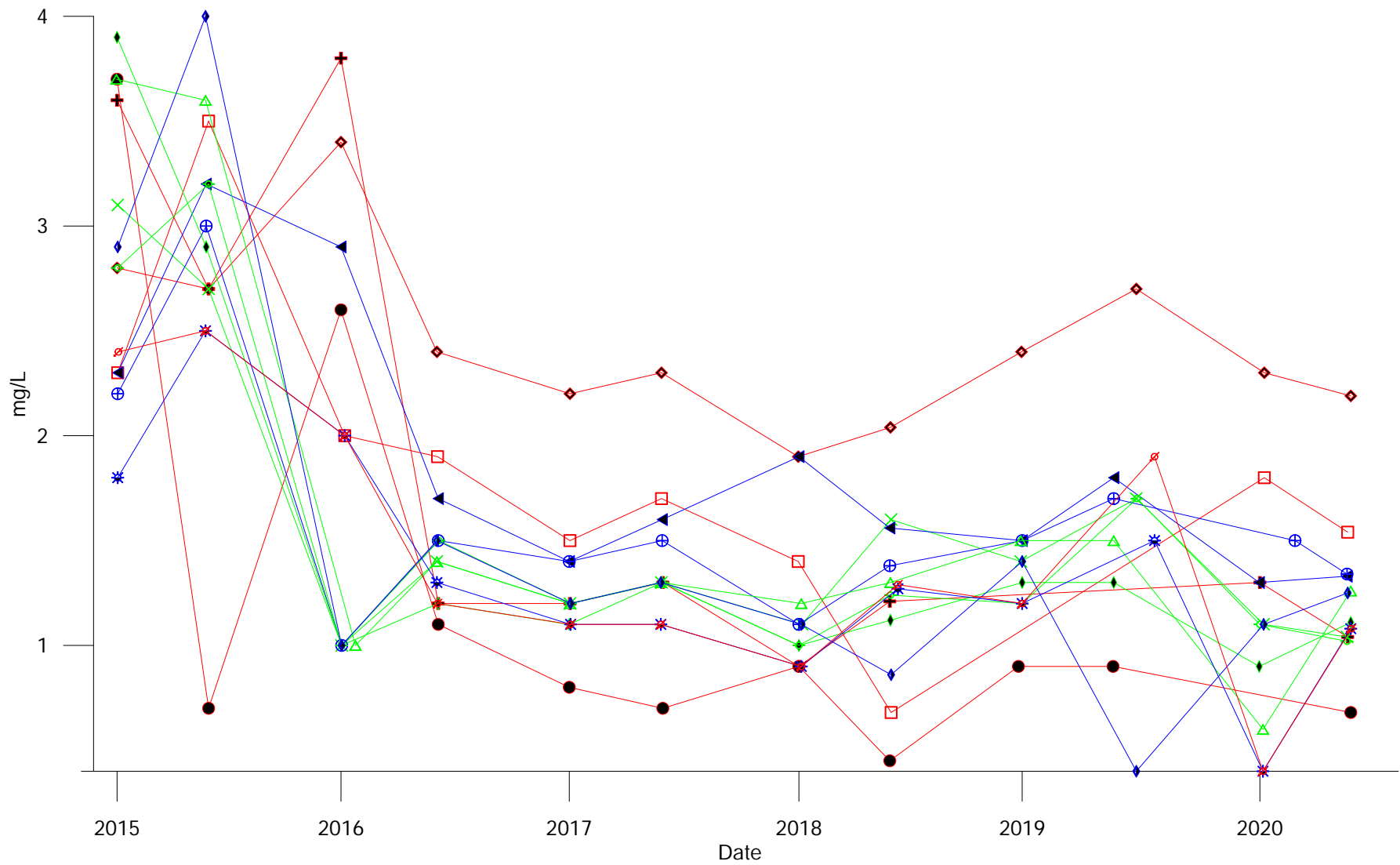

Cross gradient

- ◀◀◀ W9
- ⊕⊕⊕ W10
- ◊◊◊ W14
- ⊛⊛⊛ W15

Up gradient

- W4
- ⊕⊕⊕ W5
- ◻◻◻ W6
- ◊◊◊ W7
- ⊘⊘⊘ W16

Down gradient

- ××× W8
- ◊◊◊ W11
- ◊◊ W12
- △△△ W13



City Of Winnipeg
Solid Waste Services

BRADY ROAD RESOURCE MANAGEMENT FACILITY

TKN Concentration
Bedrock Wells

APRIL 2021

FIGURE 12

REV 0

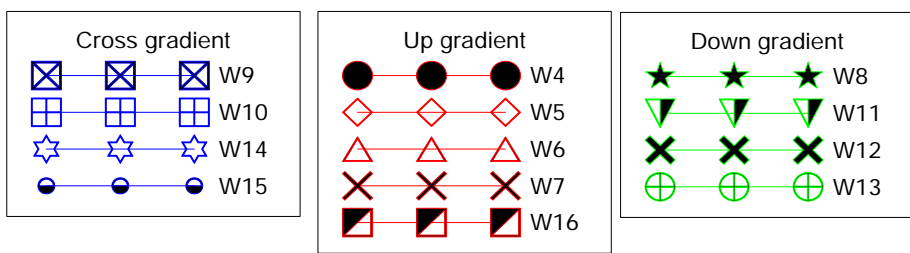
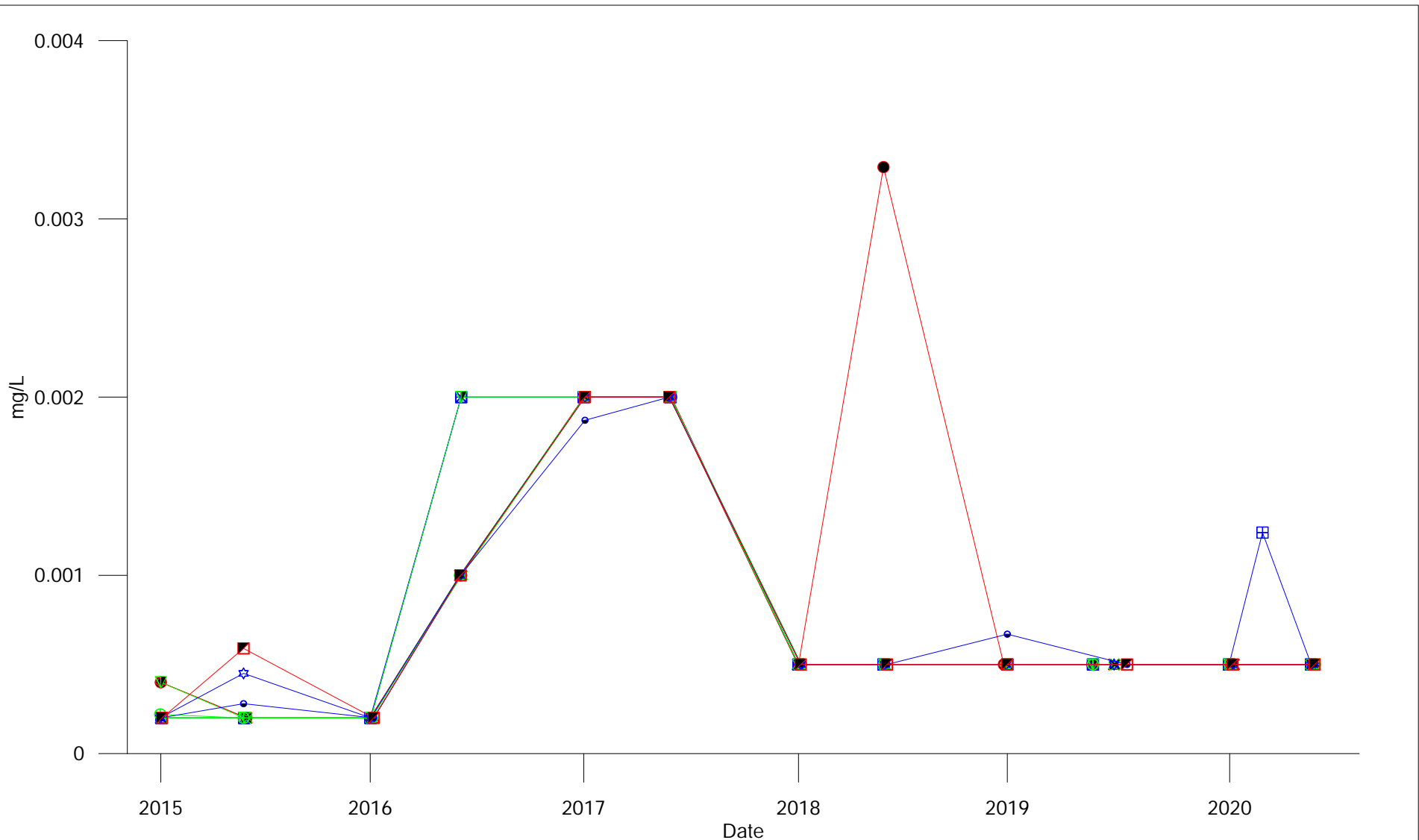

Vanadium MOE Criteria = 0.25 mg/L

	City Of Winnipeg Solid Waste Services	
	BRADY ROAD RESOURCE MANAGEMENT FACILITY	
Dissolved Vanadium Bedrock Wells		
APRIL 2021	FIGURE 13	REV 0

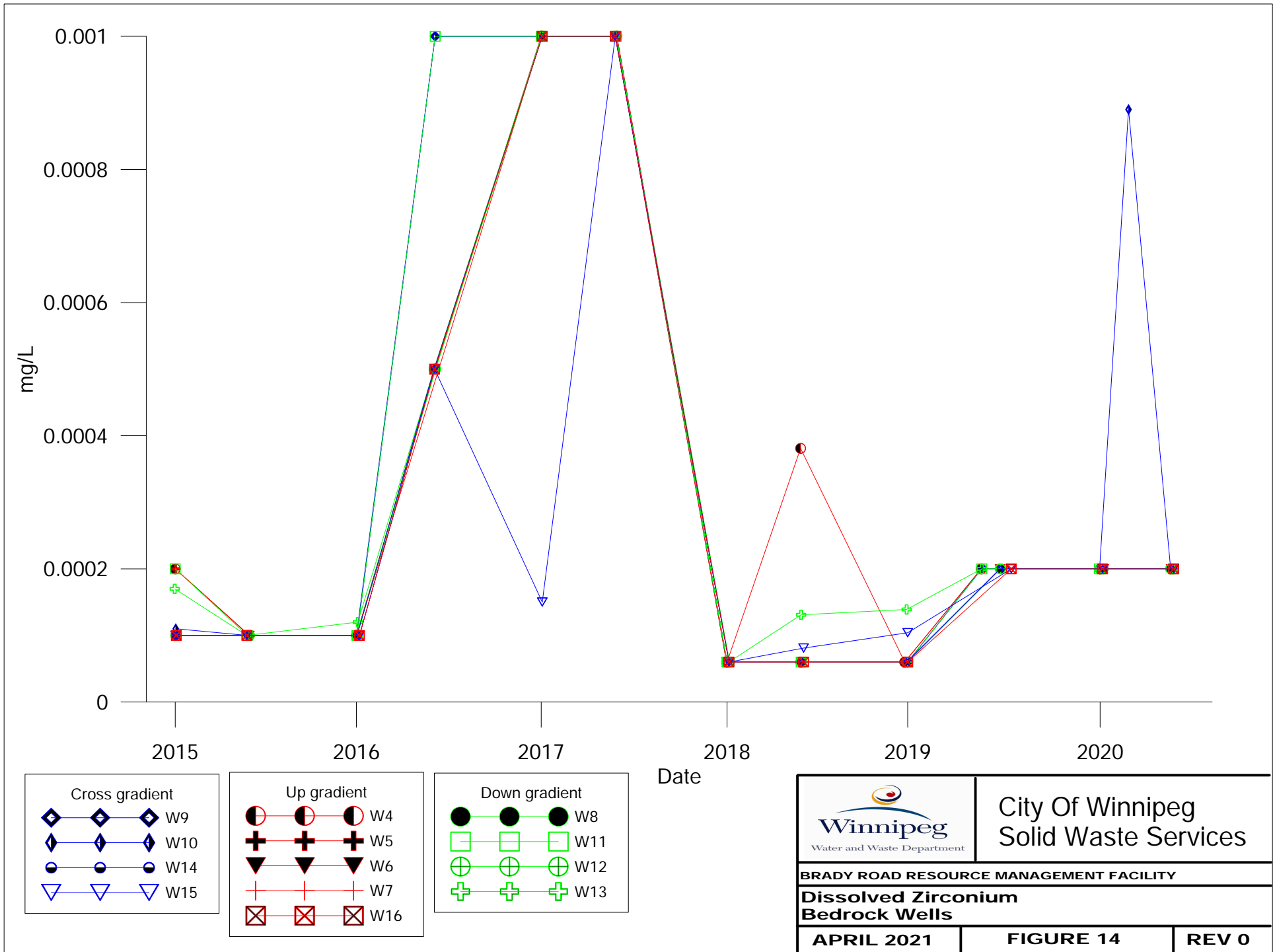

**2020 SURFACE WATER
TIME VS CONCENTRATION GRAPHS**

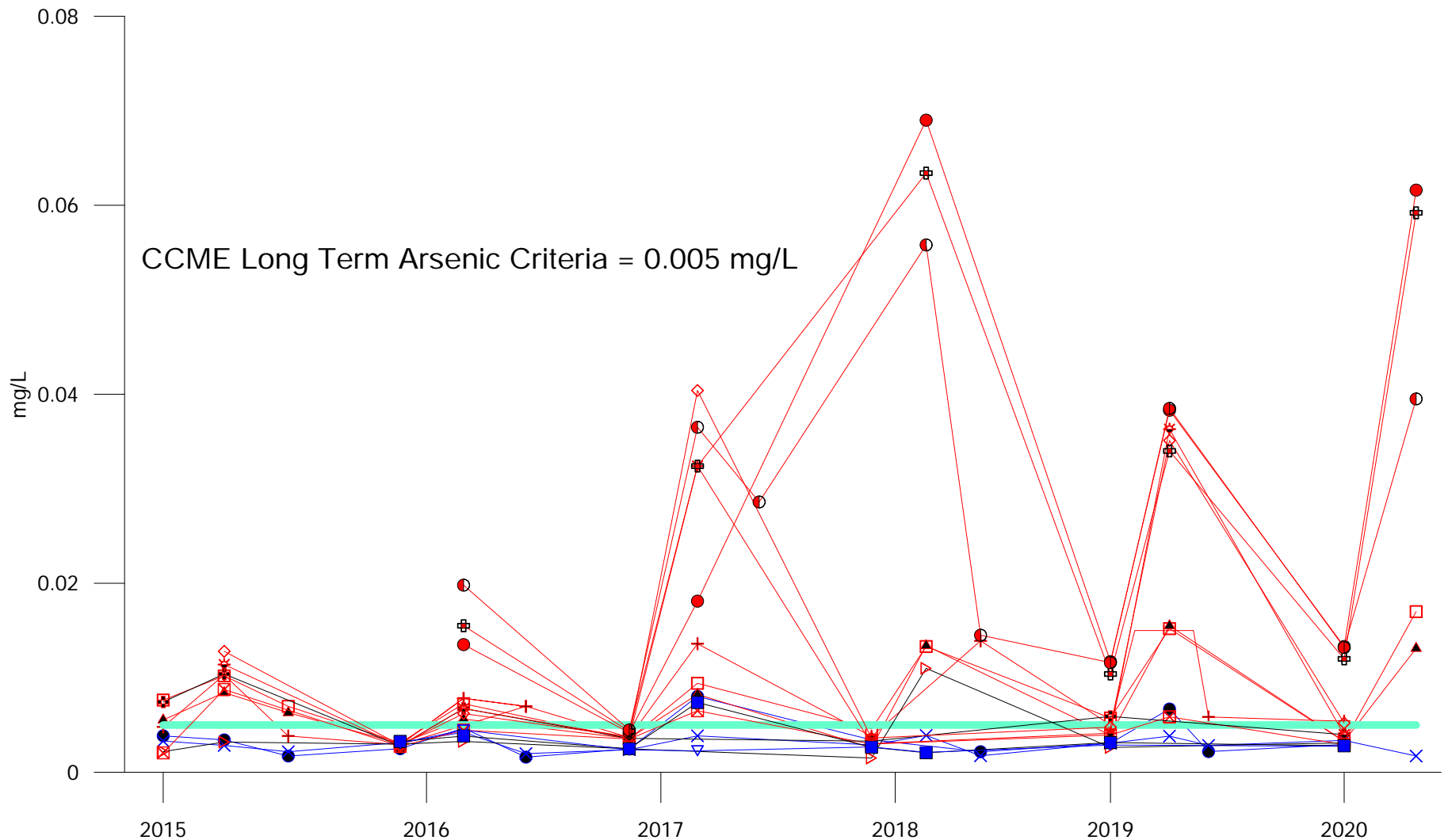

Up Stream

- SW25-1
- × SW25-12
- SW25-13A
- ▽ SW25-13B

Down Stream

- ⊠ SW25-16
- ⊕ SW25-2
- SW25-9B
- ▲ SW25-9A
- ⊞ SW25-11B
- ◐ SW25-11C

Down Stream

- ◁ CCME
- ▷ SW25-14A
- ⊞ SW25-14B
- ⊛ SW25-15A
- ◇ SW25-15B
- SW25-11A

	City Of Winnipeg Solid Waste Services	
	BRADY ROAD RESOURCE MANAGEMENT FACILITY	
Dissolved Arsenic Surface Water		
APRIL 2021	FIGURE 43	REV 0

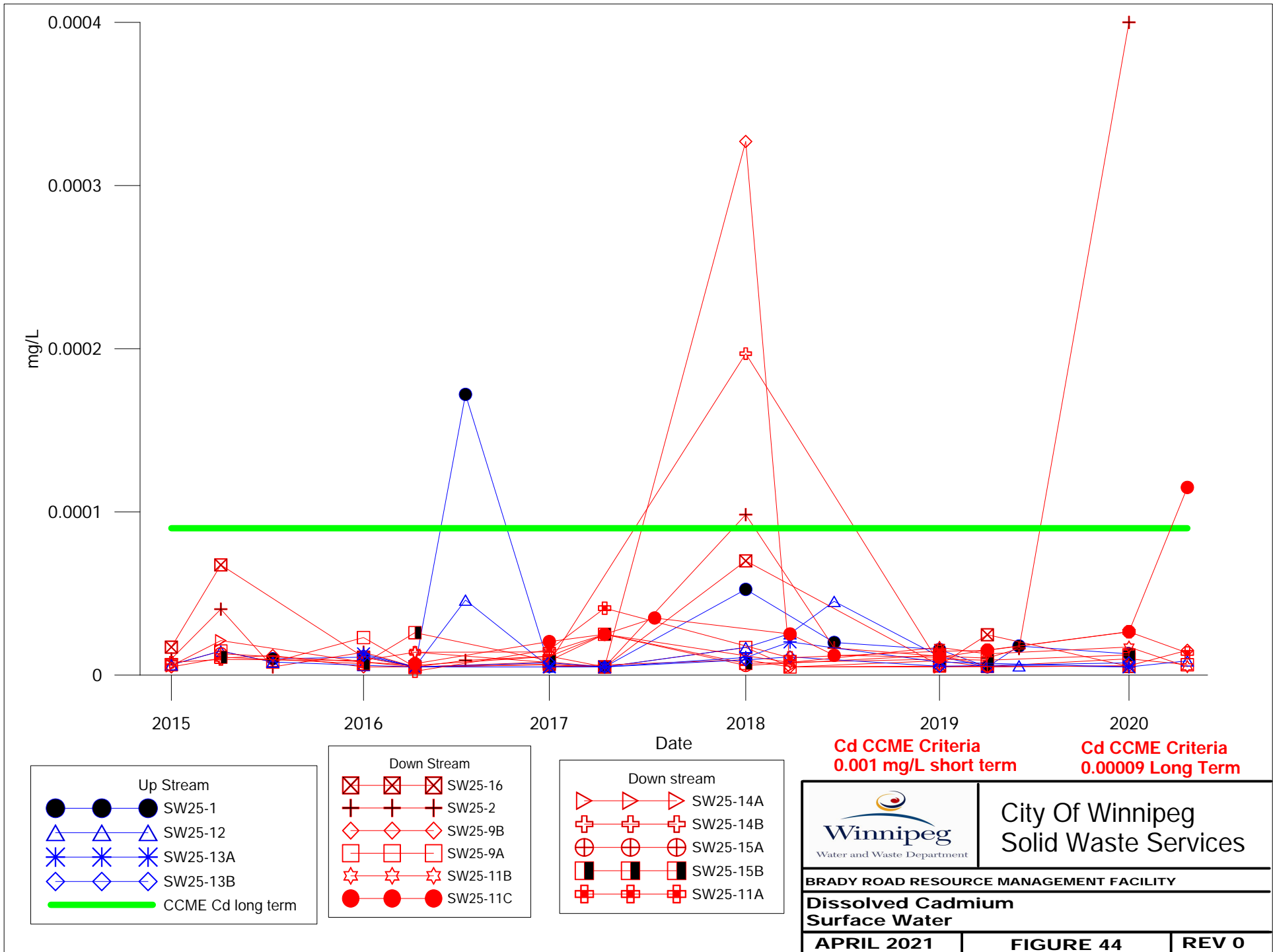

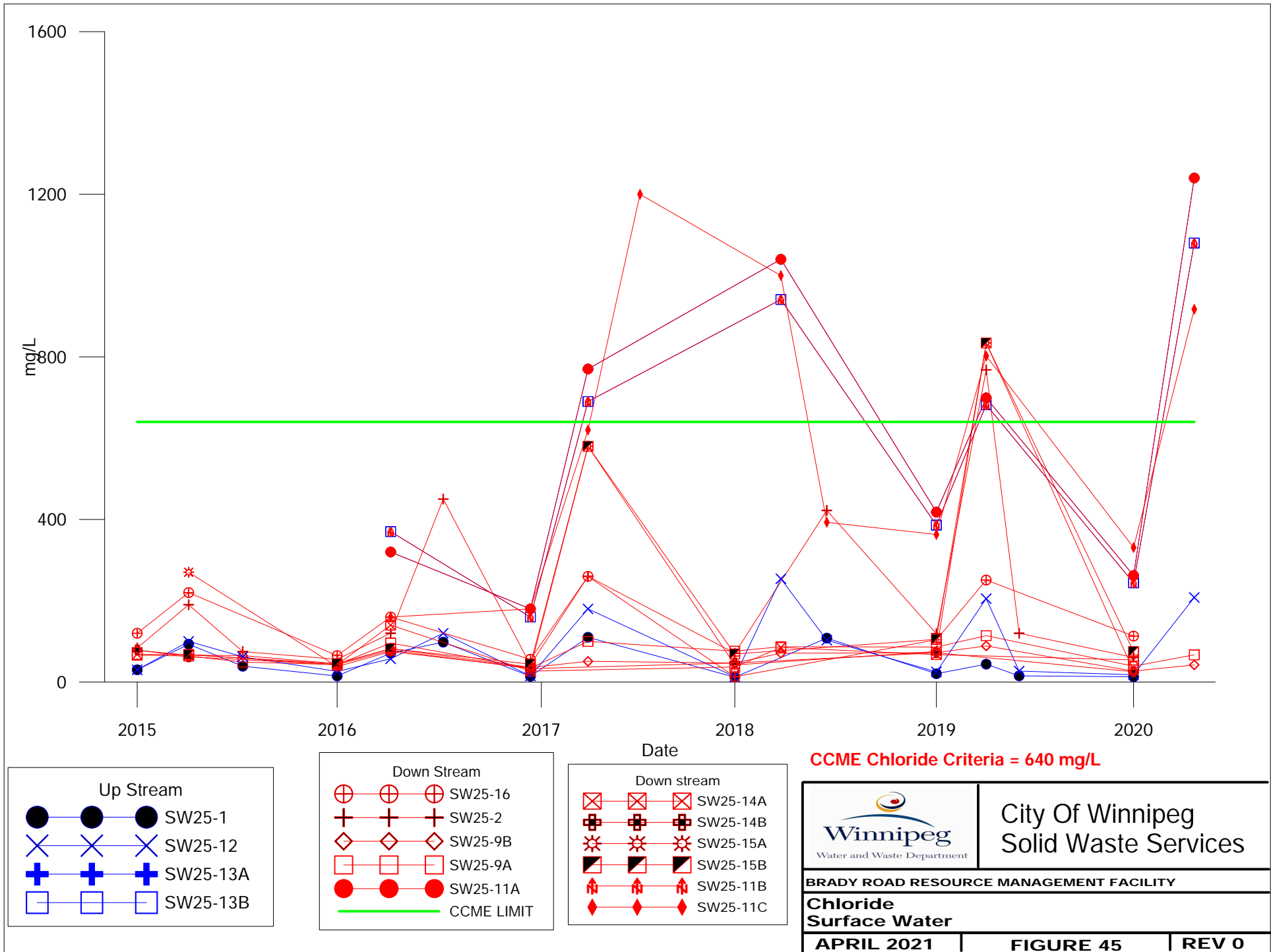

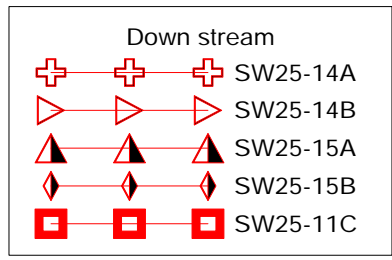
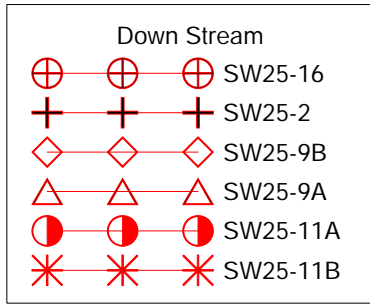
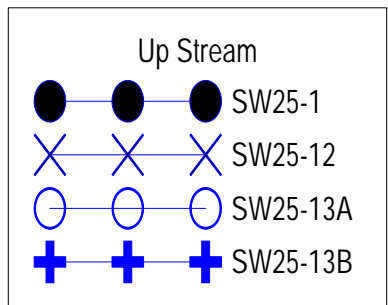
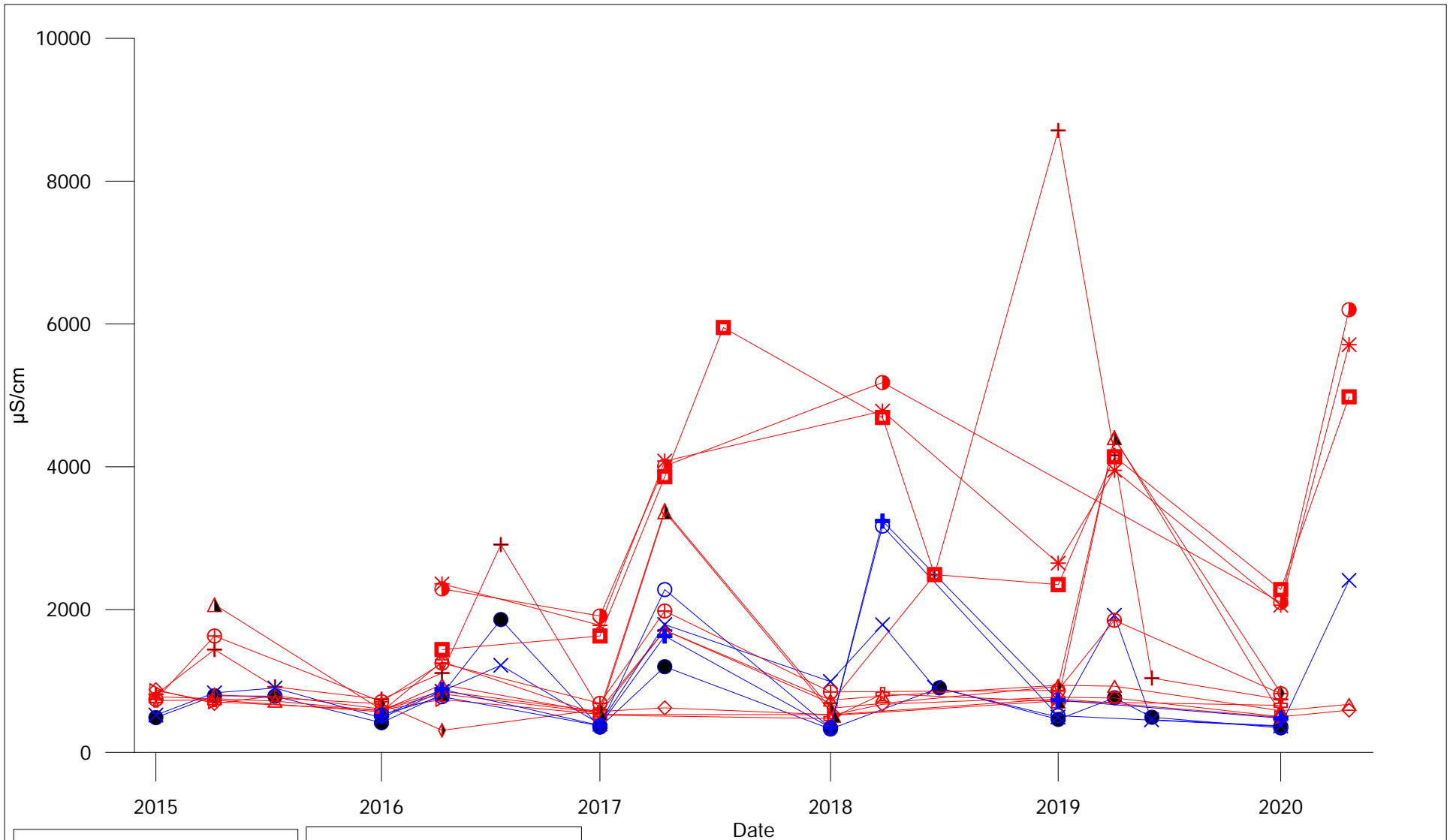

	City Of Winnipeg Solid Waste Services	
	BRADY ROAD RESOURCE MANAGEMENT FACILITY	
Specific Conductance Surface Water		
APRIL 2021	FIGURE 51	REV 0

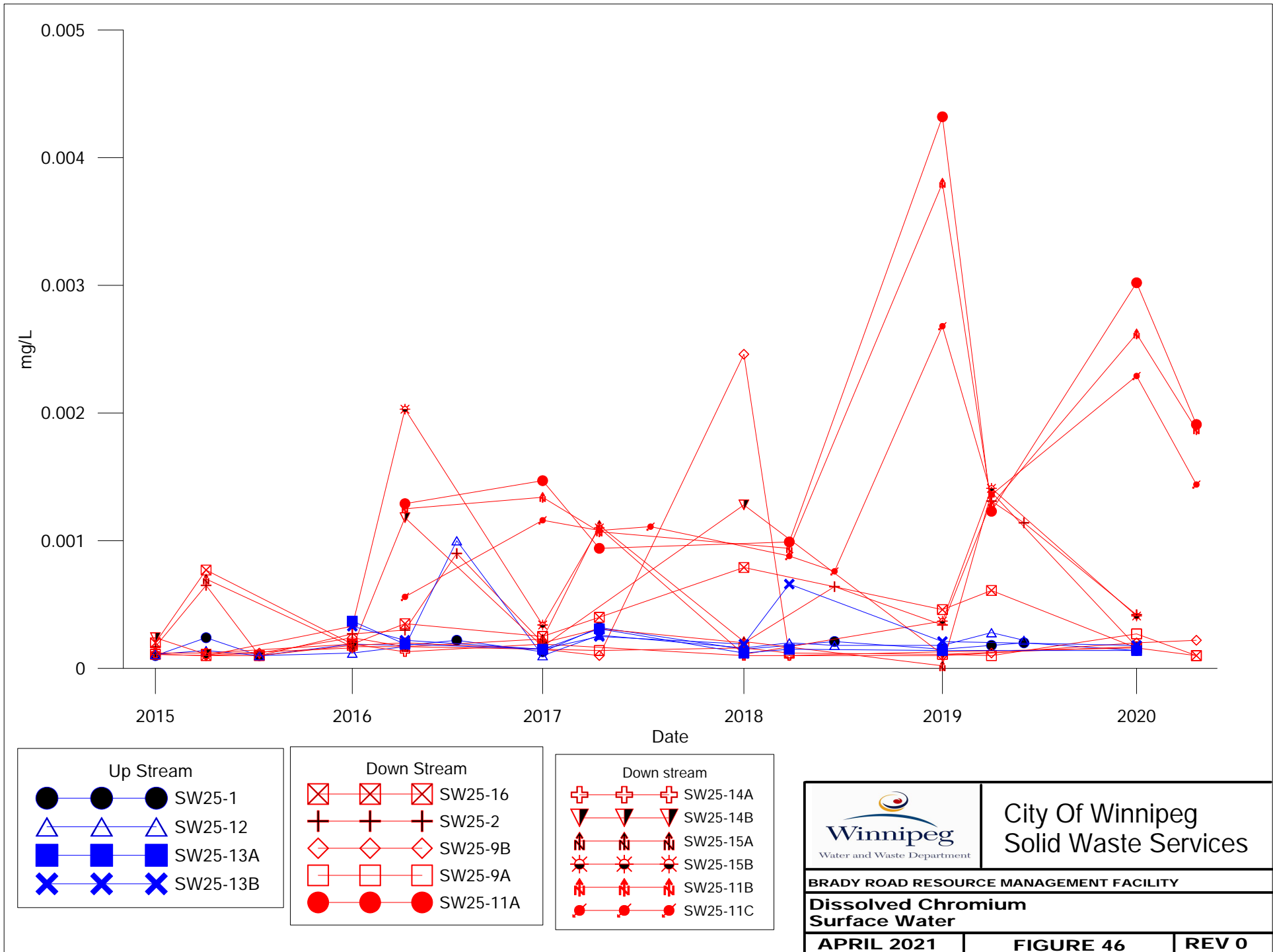

Up Stream

- SW25-1
- △ SW25-12
- SW25-13A
- × SW25-13B

Down Stream

- ⊠ SW25-16
- ⊕ SW25-2
- ◇ SW25-9B
- SW25-9A
- SW25-11A

Down stream

- ⊕ SW25-14A
- ▽ SW25-14B
- ⬆ SW25-15A
- ☀ SW25-15B
- ⬆ SW25-11B
- SW25-11C



City Of Winnipeg
Solid Waste Services

BRADY ROAD RESOURCE MANAGEMENT FACILITY

Dissolved Chromium
Surface Water

APRIL 2021

FIGURE 46

REV 0

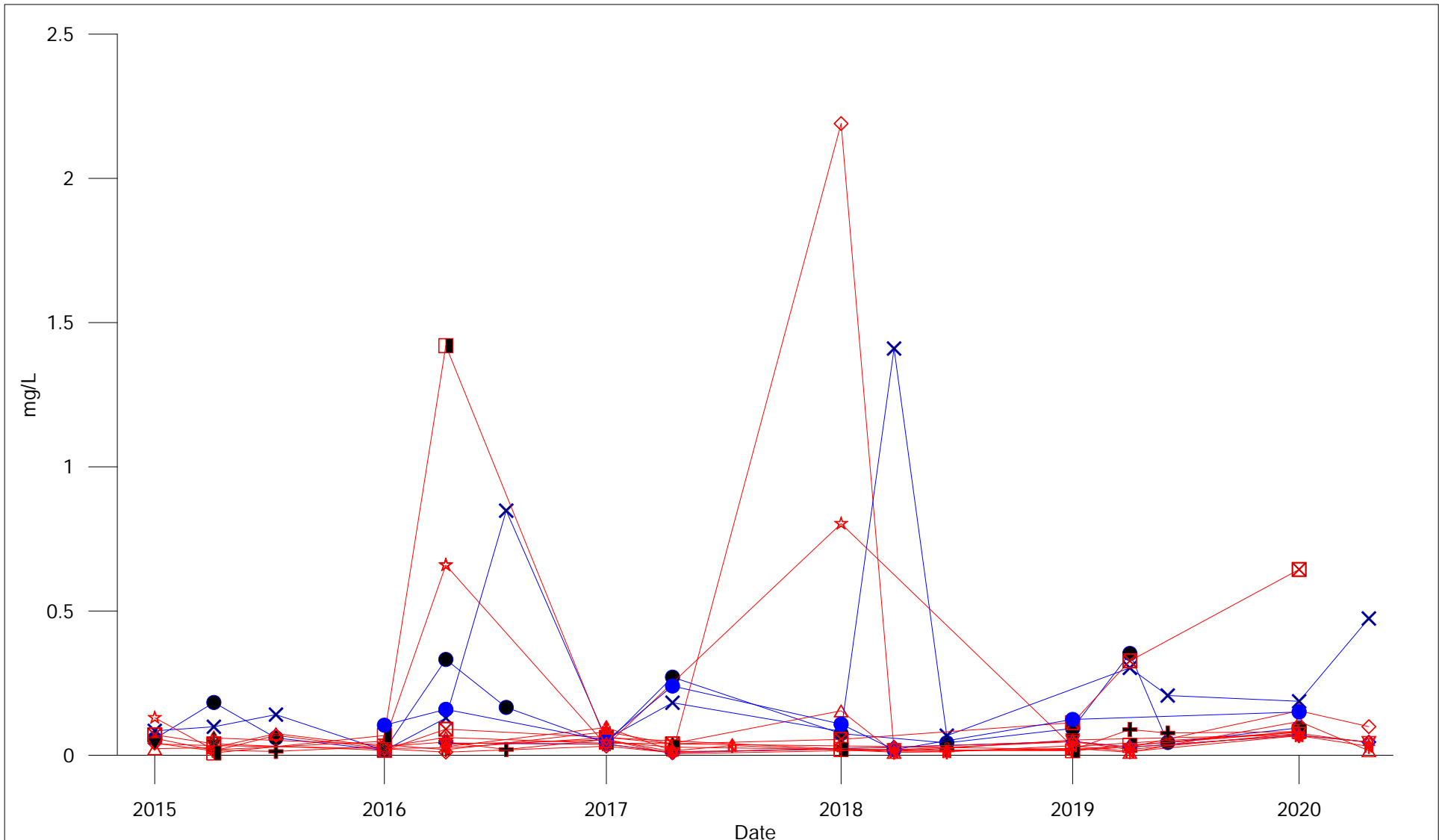

Up Stream

- SW25-1
- × SW25-12
- SW25-13A
- ◇ SW25-13B

Down Stream

- ⊠ SW25-16
- ⊕ SW25-2
- ◇ SW25-9B
- △ SW25-9A
- ▽ SW25-11A

Down Stream

- ▼ SW25-14A
- ☆ SW25-14B
- ⬆ SW25-15A
- ⊠ SW25-15B
- ☆ SW25-11B
- ⬆ SW25-11C

	City Of Winnipeg Solid Waste Services	
	BRADY ROAD RESOURCE MANAGEMENT FACILITY	
Dissolved Iron Surface Water		
APRIL 2021	FIGURE 47	REV 0

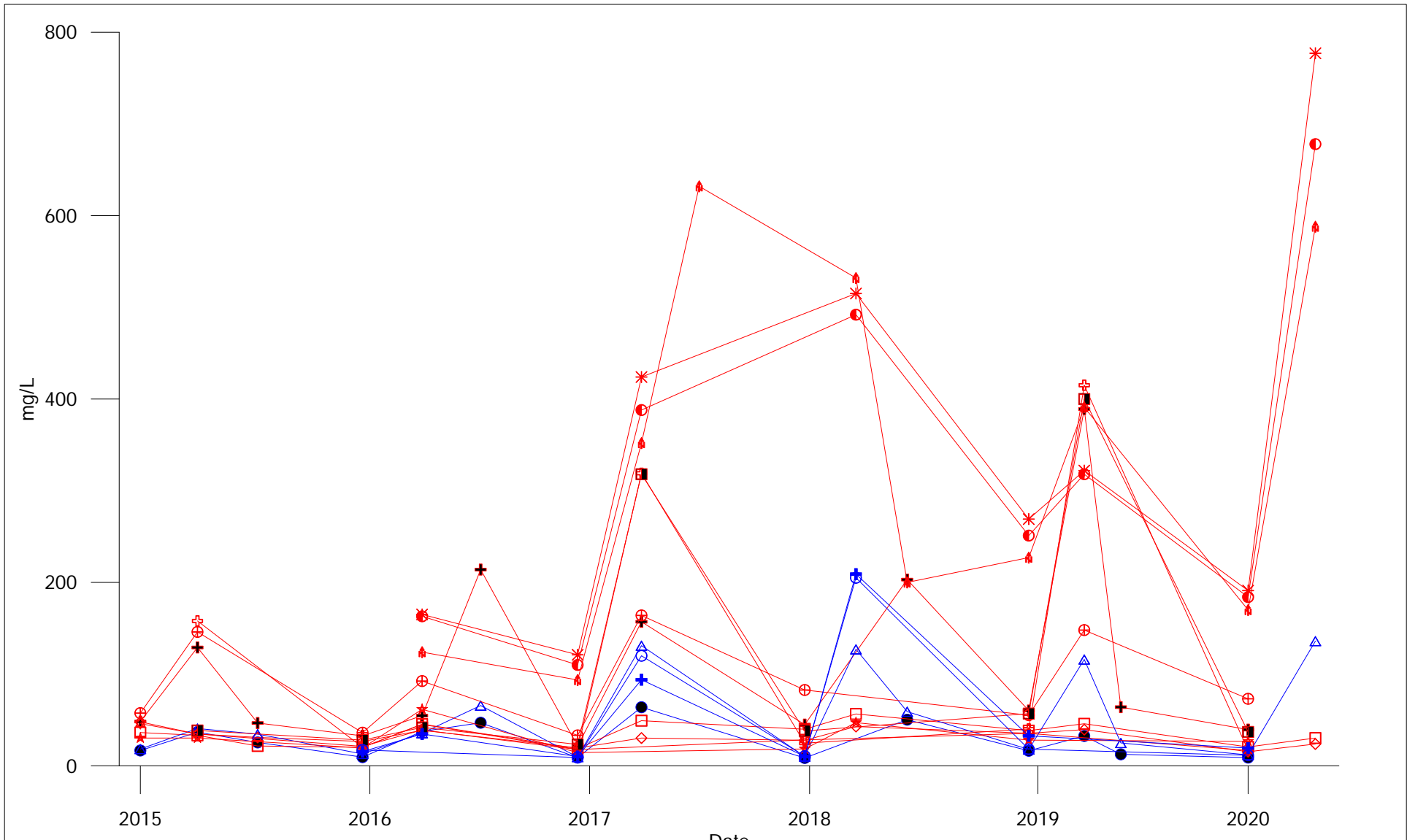

Up Stream

- SW25-1
- △ SW25-12
- SW25-13A
- ⊕ SW25-13B

Down Stream

- ⊕ SW25-16
- ⊕ SW25-2
- ◇ SW25-9B
- SW25-9A
- * SW25-11A
- SW25-11B

Down stream

- ☆ SW25-14A
- ☆ SW25-14B
- ⊕ SW25-15A
- SW25-15B
- ♠ SW25-11C

	City Of Winnipeg Solid Waste Services	
	BRADY ROAD RESOURCE MANAGEMENT FACILITY	
Dissolved Sodium Surface Water		
APRIL 2021	FIGURE 50	REV 0

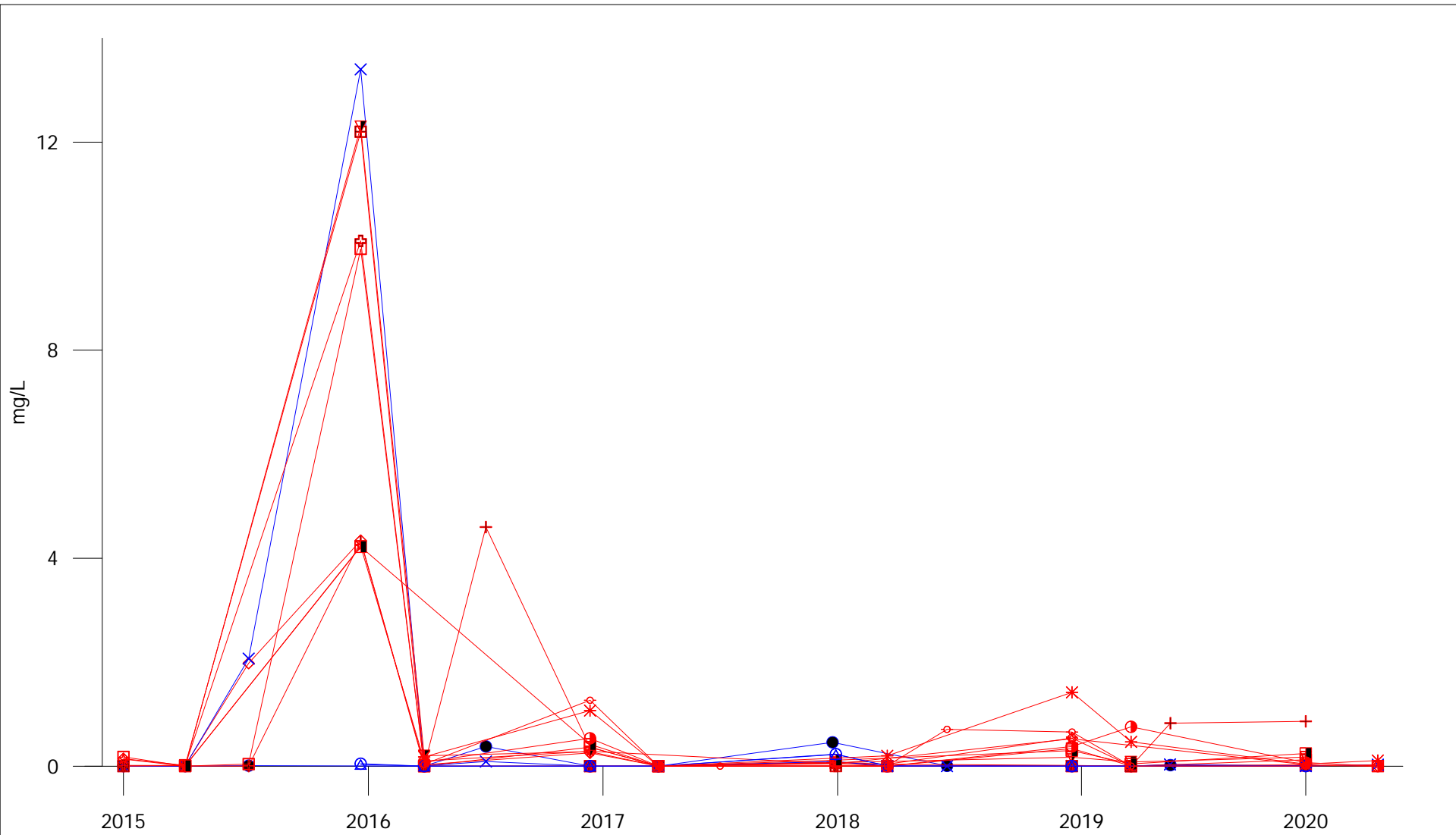

<p>Up Stream</p> <ul style="list-style-type: none"> ● SW25-1 × SW25-12 ○ SW25-13A △ SW25-13B 	<p>Down Stream</p> <ul style="list-style-type: none"> ⊠ SW25-16 ⊕ SW25-2 ◇ SW25-9B □ SW25-9A ◐ SW25-11A ✱ SW25-11B 	<p>Down stream</p> <ul style="list-style-type: none"> ⊕ SW25-14A ☆ SW25-14B ▼ SW2-15A ◼ SW25-15B ○ SW25-11C 	 <p>City Of Winnipeg Solid Waste Services</p>
<p>BRADY ROAD RESOURCE MANAGEMENT FACILITY</p>			
<p>Nitrate Nitrite as Nitrogen Surface Water</p>			
<p>APRIL 2021</p>	<p>FIGURE 49</p>	<p>REV 0</p>	

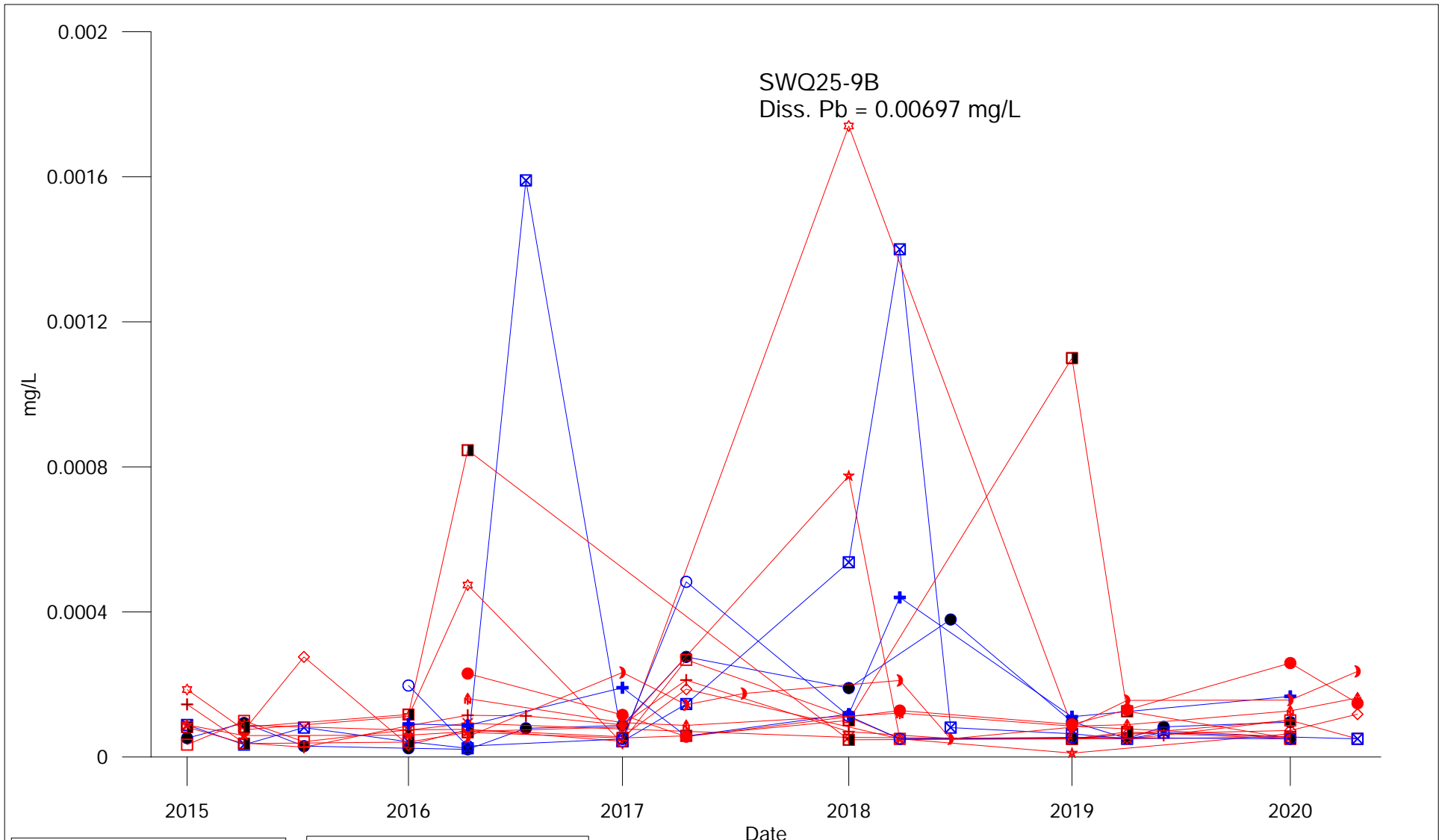

Up Stream

- SW25-1
- ⊠ SW25-12
- SW25-13A
- ⊕ SW25-13B

Down Stream

- ◻ SW25-16
- ⊕ SW25-2
- ◇ SW25-9B
- ◻ SW25-9A
- SW25-11A

Down stream

- ☆ SW25-14A
- ☆ SW25-14B
- ⊗ SW25-15A
- ◻ SW25-15B
- ⦶ SW25-11B
- ☾ SW25-11C

	City Of Winnipeg Solid Waste Services	
	BRADY ROAD RESOURCE MANAGEMENT FACILITY	
Dissolved Lead Surface Water		
APRIL 2021	FIGURE 48	REV 0

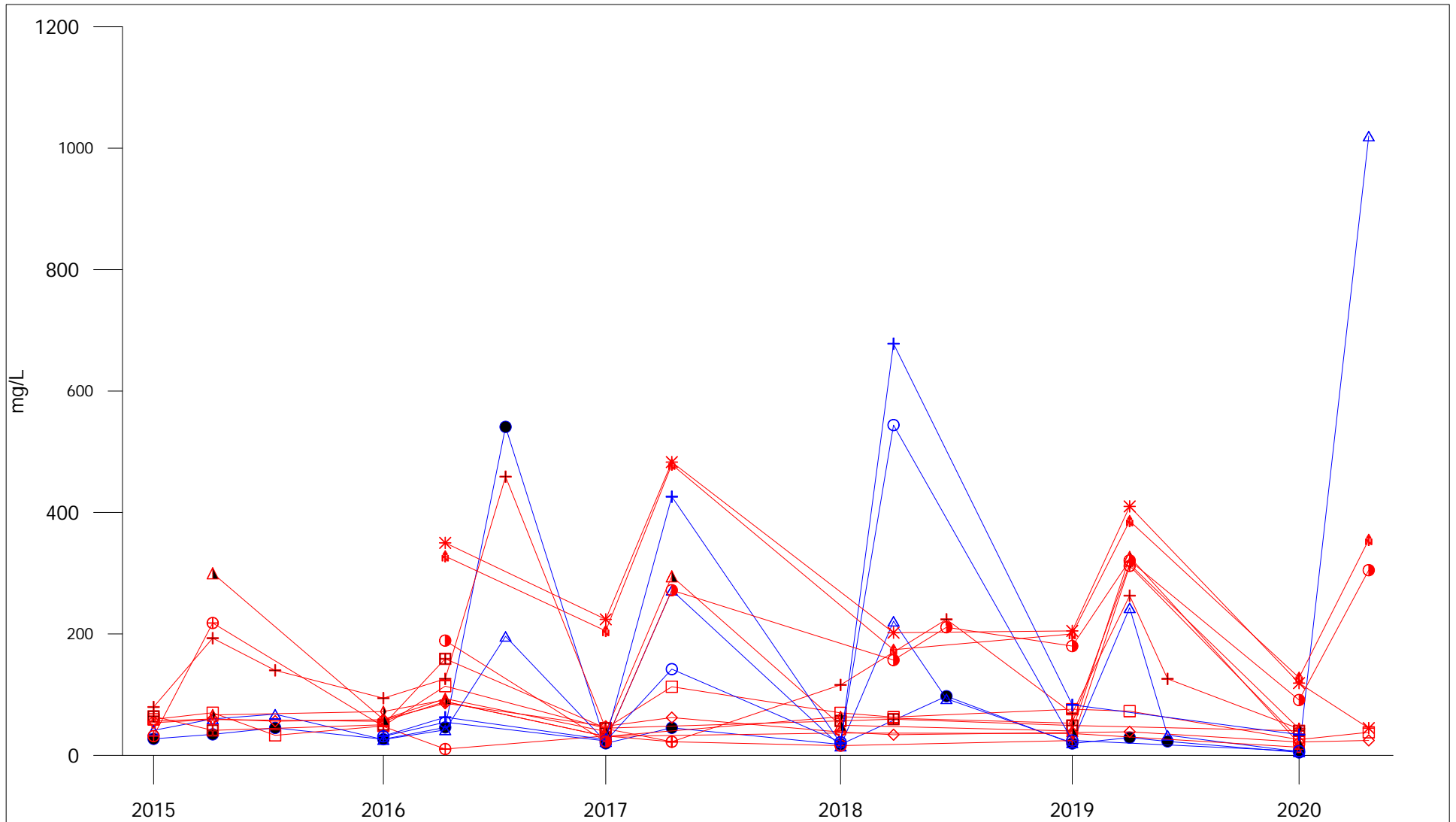

Up Stream

- SW25-1
- △ SW25-12
- SW25-13A
- + SW25-13B

Down Stream

- ⊕ SW25-16
- + SW25-2
- ◇ SW25-9B
- SW25-9A
- * SW25-11A
- ↑ SW25-11B

Down stream

- ⊕ SW25-14A
- + SW25-14B
- ▲ SW25-15A
- ◆ SW25-15B
- ◐ SW25-11C

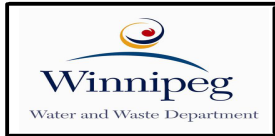

City Of Winnipeg
Solid Waste Services

BRADY ROAD RESOURCE MANAGEMENT FACILITY		
Sulfate Surface Water		
APRIL 2021	FIGURE 52	REV 0

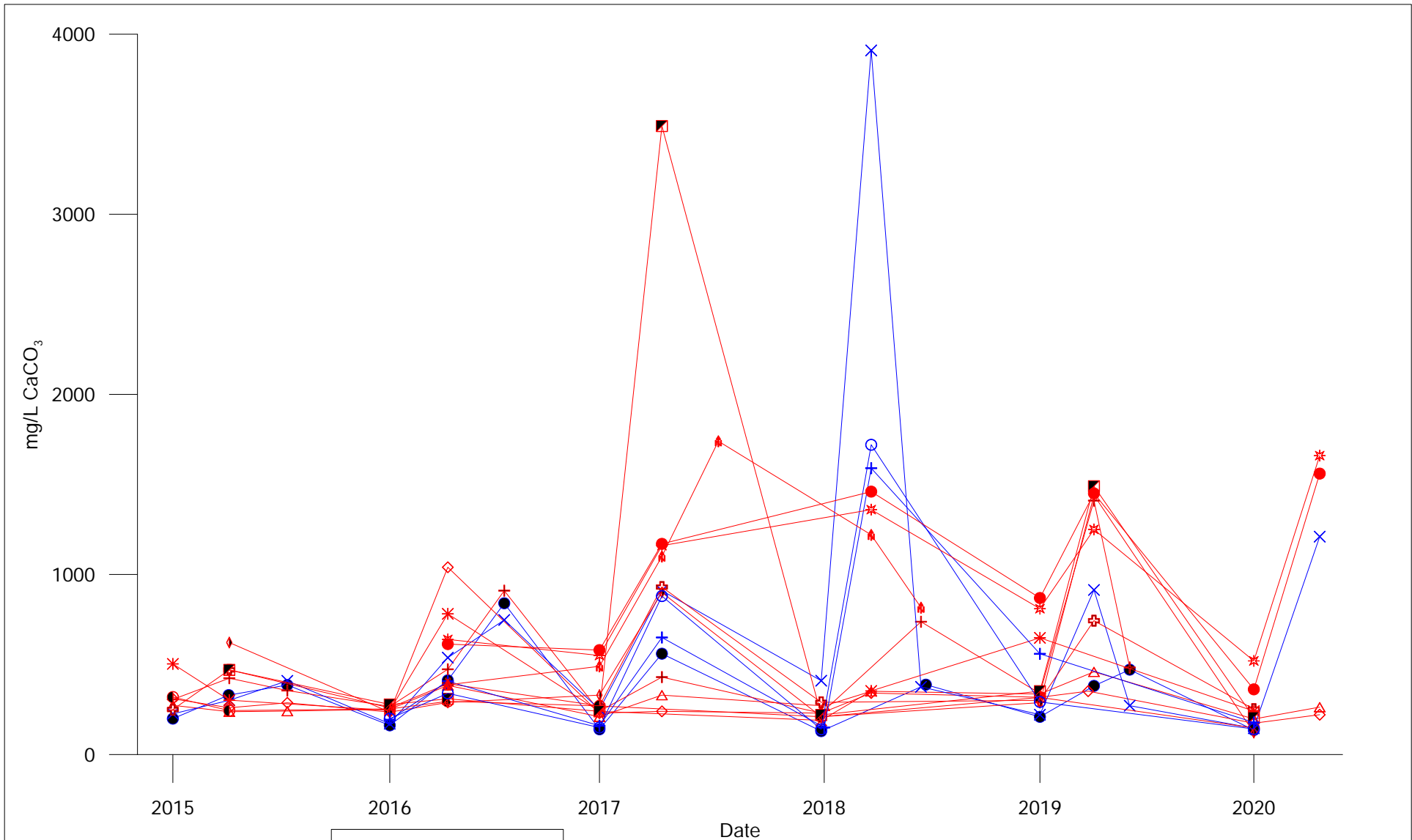

Up Stream

- ● ● SW25-1
- × × × SW25-12
- ○ ○ SW25-13A
- + + + SW25-13B

Down Stream

- ⊕ ⊕ ⊕ SW25-16
- + + + SW25-2
- ◇ ◇ ◇ SW25-9B
- △ △ △ SW25-9A
- ● ● SW25-11A
- * * * SW25-11B

Down stream

- ⊗ ⊗ ⊗ SW25-14A
- ◐ ◐ ◐ SW25-14B
- ◑ ◑ ◑ SW25-15A
- ◓ ◓ ◓ SW25-15B
- ⬆ ⬆ ⬆ SW25-11C



City Of Winnipeg
Solid Waste Services

BRADY ROAD RESOURCE MANAGEMENT FACILITY

**Total Hardness
Surface Water**

APRIL 2021 | FIGURE 53 | REV 0

APPENDIX D
2020 LANDFILL GAS
COLLECTION AND FLARING
REPORT

**2020 ANNUAL MONITORING REPORT
CITY OF WINNIPEG**

**BRADY ROAD RESOURCE MANAGEMENT FACILITY
LANDFILL GAS COLLECTION AND FLARING SYSTEM**

Prepared for

THE CITY OF WINNIPEG

Prepared by

INTEGRATED GAS RECOVERY SERVICES INC.

March 25, 2021



2020 ANNUAL MONITORING REPORT CITY OF WINNIPEG

BRADY ROAD RESOURCE MANAGEMENT FACILITY LANDFILL GAS COLLECTION AND FLARING SYSTEM

1.0	INTRODUCTION.....	1
2.0	LANDFILL GAS COLLECTION SYSTEM.....	2
2.1	Wellfield System Expansions	2
2.2	Wellfield System Monitoring	3
2.3	Surface Emission Monitoring	5
2.4	Mechanical System Monitoring.....	5
2.4.1	System Pressure Measurements.....	6
2.4.2	System Gas Measurements	6
2.4.3	System Flow Rate Measurements.....	7
3.0	FLARE AND GREENHOUSE GAS EMISSIONS.....	8
3.1	Flare Emissions.....	8
3.2	Greenhouse Gas Emissions.....	8
4.0	CONDENSATE COLLECTION SYSTEM.....	9
5.0	CONCLUSIONS AND RECOMMENDATIONS.....	10

LIST OF FIGURES

Following Page

Figure 1: Existing Conditions.....	2
------------------------------------	---

LIST OF TABLES

Page

Table 1: Summary of Monitoring Frequency.....	2
Table 2: Wellfield Monitoring Data.....	following page 4
Table 3: Pump Counters.....	following page 4
Table 4: Leachate Levels.....	following page 4

LIST OF APPENDICES

APPENDIX A Plant and Flare Data

1.0 INTRODUCTION

The City of Winnipeg operates the Landfill Gas Collection and Flaring System at the Brady Road Resource Management Facility in Winnipeg, Manitoba, which operates under Manitoba Conservation Licence 3081. After a short commissioning phase, the system became operational full time in August 2013 after approval to operate was received by the Office of the Fire Commissioner.

Operation of the system including maintenance and monitoring was completed by Comcor Environmental Limited (Comcor) on behalf of its partner Integrated Gas Recovery Services (IGRS).

This report outlines work performed and data collected during the operation of the Landfill Gas Collection and Flaring System during 2020.

2.0 LANDFILL GAS COLLECTION SYSTEM

There are two main components of the LGCFS that require monitoring. These include:

- Landfill Gas Collection Wellfield
- Mechanical System

The purpose and procedures associated with the monitoring of each of these components are discussed separately below. The recommended monitoring frequency is presented in Table 1.

Table 1: Summary of Monitoring Frequency

System Component	Monitoring Frequency
Wellfield Monitoring	Monthly
Remote Mechanical System Monitoring	Weekly
Mechanical System Monitoring	Weekly

2.1 Wellfield System Expansions

In April 2020, a tender was issued by the City of Winnipeg for an expansion of the landfill gas collection system. Figure 1 presents the approximate existing wellfield conditions at the site as as-builts including the 2020 expansion have yet to be finalized.

The 2020 expansion included a landfill gas collection system expansion in the northwest corner of the site, consisting of 18 new dual purpose wells, each equipped with a QED AP3 pneumatic pump for leachate extraction. Four perforated horizontal gas collectors were also installed in Cell 32 under newly deposited waste, and connected via 150 mm sub-lateral piping to Lateral 7. A second 150 mm sub-lateral was also installed to the eastern limit of Cell 33 for the installation of future horizontal gas collectors. Gas collection was also added to three leachate manholes at the end of Charette Road (MH3, 4 and 5), and gas tight HDPE lids were installed at a total of 21 leachate manholes and three leachate sumps to further reduce odours.

In addition to the new collection system infrastructure, the 2020 expansion also included the retrofitting of 57 existing gas wells to dual purpose to allow for leachate extraction. Compressed air and forcemain piping are now installed to all vertical extraction wells on site, along with QED AP3 pneumatic pumps. Powering the pumps will be a container-mounted 60 HP Atlas Copco air compressor system installed in the flaring compound. At the time of writing this report, the air compressor container had yet to be delivered. Delivery and commissioning of the air compressor container is expected to occur by the end of March 2021.

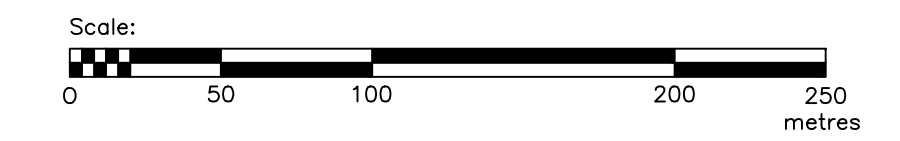
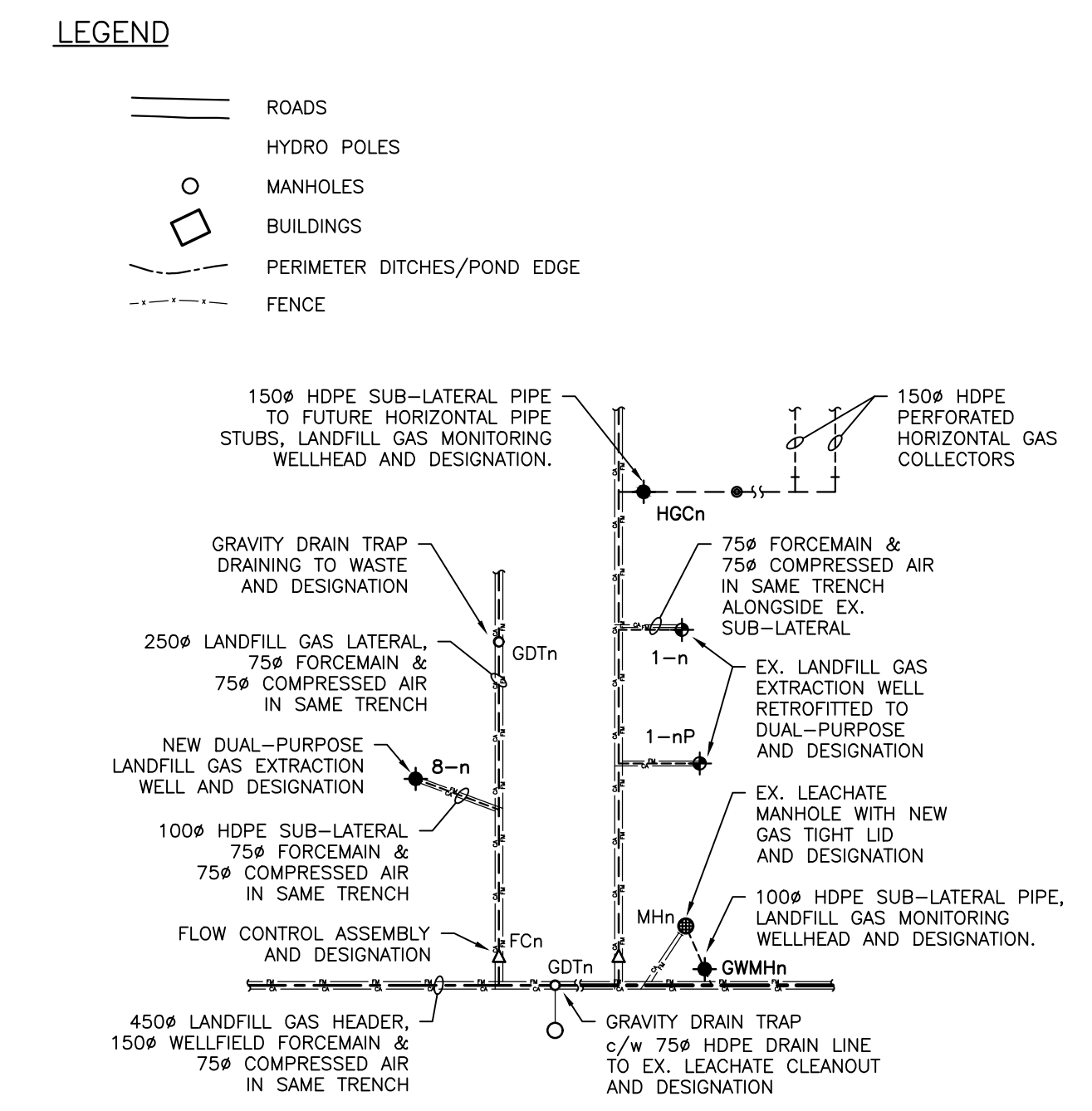

NOTES:
 1. DRAWING SHOWS INFRASTRUCTURE ASSOCIATED WITH 2020 WELLFIELD AND DUAL-PURPOSE EXPANSION AS PER THE "FOR CONSTRUCTION" LAYOUT. AS-BUILT CONDITIONS FROM THIS EXPANSION HAVE NOT BEEN INCORPORATED INTO DRAWING.

COMCOR
 ENVIRONMENTAL LIMITED
 Consulting Engineers and Landfill Gas Specialists
 320 Pinebush Road, Suite 12, Cambridge, Ontario N1T 1Z6
 tel (519) 621-6669 • fax (519) 621-9944

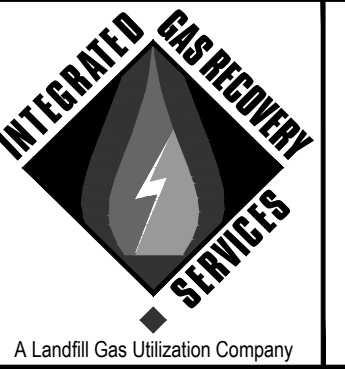

City of Winnipeg
 Brady Road
 Resource Management
 Facility

FIGURE 1
 EXISTING SITE CONDITIONS
 MARCH 2021

Previous to the expansion, Comcor identified that a number of the existing flow control assemblies were malfunctioning, primarily due to broken shear pins in the valves' gearboxes. These issues were remediated and included as a change order to the 2020 expansion contract.

2.2 Wellfield System Monitoring

The wellfield system monitoring consists of measuring vacuum/pressure in each well and lateral pipe, as well as the percentage of methane, oxygen and carbon dioxide in the landfill gas, and parts per million of carbon monoxide and hydrogen sulphide at each location. These measurements were taken using a proper gas meter/analyzer such as a Landtec GEM-5000, or equivalent. Vacuum fluctuations were noted, as it can be an indication of water within the piping system.

Each wellhead was monitored for the velocity of gas using an anemometer. The measured velocities were used to calculate landfill gas flow rates by multiplying the velocity by the pipe cross-sectional area.

The monitoring data collected during the monthly round is beneficial to determine if the wellfield is operating as intended. Changes to the wellhead valve position were made to ensure maximum gas collection from the landfill. The system was monitored and field balanced by a technician experienced in the operation of this type of system.

The new wells installed in 2020 were not monitored as the wells were not opened until December 2020. The pump counters at the new/retrofitted wells were also not monitored in 2020 since the new air compressor has not been commissioned.

During 2020, there were no elevated levels of Carbon Monoxide (CO) (>500 ppm). Previous elevated levels occasionally found at GW 2-13 and GW 1-7 as noted in the 2018 Annual Report were remediated. The highest CO levels at GW 1-7 and 2-13 during the 2020 monitoring period were both recorded in the June monitoring round and were 268 ppm and 188 ppm, respectively. From mid 2016 to October 2017, GW1-7 was closed due to low methane levels and high CO. The CO levels dropped in late 2017 and the temperature readings were within a more typical range, and thus the well was cracked for gas collection. The highest CO levels at 1-7 tends to occur during spring and summer. Elevated carbon monoxide within landfill gas can be an indicator of a subsurface fire within the waste. There was no indication of a subsurface fire in 2020.

The wellfield monitoring data and valve positions can be found in Table 2.

Pump counter measurements were recorded on a monthly basis at all active dual purpose gas/leachate collection wells. During the monthly pump counter measurements, the following items were noted:

- The pump counter at PDT1 was replaced in June 2020.
- The regulators were being repaired in July and August of 2020 at I-9, I-10, 2-18, and 3-30. Values were not recorded during these months.

- The pump counters at PDT4, PDT5, and PDT7 were not functioning throughout the 2020 reporting year due to flooding, thus readings were not recorded. The pumps however are working and are monitored to ensure that they are still operational.
- The pump counters at I-9, I-10, and 3-29 were not functioning during various months in the 2020 reporting year due to issues with the compressed air lines, thus readings were not recorded in some months.
- The pump at 3-27 was not operating properly and as a result was pulled for most of the 2020 reporting year, thus readings were not recorded.
- The pump counter at 3-30 was not functioning properly during various months in the 2020 reporting year, thus readings were not recorded in some months.
- The pump counter at 2-18 was removed for the month of May 2020. The pump counter was replaced in June, August, and November of 2020.

In instances when there was a lack of a functioning pump counter, the pumps were checked on a monthly basis to confirm operation, and were found to be functioning as intended at all inspections. Table 3 presents the pump counter measurements recorded at both the pump drain traps and active dual purpose wells in 2020. Once Covid restrictions are lifted, many pump counter confined space repairs can be completed to have all counters working again.

Water level monitoring requirements are for water levels to be measured on a semi-annual basis. Table 4 presents the water levels measured in 2020. The percent of open screen available for gas collection at each well is estimated based on water levels.

Based on pump counters and water levels recorded throughout 2020, dual purpose well pumps continue to remove leachate consistently. In 2020, the majority of the monitored dual-purpose wells have open screen percentages above 40%.

In August and June 2018, pumps at wells 3-27 and 3-30 respectively, were reinstalled due to suspicion that they may not be functioning as designed as a result of leachate and siltation residue making the pump inoperable. Although the pump at well 3-30 operated as intended throughout 2020 with the exception of months with a malfunctioning pump counter, the pump at well 3-27 did not operate as intended and was pulled out of the well for most of the year. The well should be monitored for residue build up and if it continues a vacuum truck could be considered to extract the silt/residue from the well to allow for operation of the pump

Table 2: Wellfield Monitoring Data

Units			13/Jan/20	20/Feb/20	22/Mar/20	25/Apr/20	20/May/20	20/Jun/20	20/Jul/20	24/Aug/20	27/Sep/20	28/Oct/20	28/Nov/20	16/Dec/20	
Weather Conditions			cloudy	cloudy	Cloudy	Clear	Clear	Clear	Clear	Clear	Clear	Clear	Clear	Clear	
Ambient Temperature °C			-24	-22	-15	15	22	28	25	23	23	10	-12	-16	
Control Panel	Flow Rate	CFM	800	800	800	800	800	800	800	800	800	900	800	800	
	CH ₄	%	39.9	48.4	50.4	50.3	51.1	50.9	46.6	45.8	42.5	40.1	39.8	47.0	
	O ₂	%	5.5	3.2	1.5	1.7	0.9	1.2	1.8	2.6	3.0	3.7	3.9	2.9	
	Wellfield Vac	"H ₂ O	8.9	9.2	10.3	10.6	-9.3	-10.1	-9.4	-9.9	-10.5	-12.4	-14.3	-13.3	
	Outlet Press.	"H ₂ O	4.1	3.8	4.3	4.1	4.4	4.2	4.2	4.1	4.1	4.1	4.2	3.7	
LOCATIONS															
H-1 well bore seal	Well	"H ₂ O	-1.04	-1.05	-1.02	-2.69	-7.28	-6.01	-4.98	-5.84	-6.75	-3.66	-0.16	-1.56	
	Lateral	"H ₂ O	-1.72	-4.94	-4.23	-6.32	-8.37	-8.44	-8.12	-7.50	-11.10	-9.27	-13.39	-11.58	
	CH ₄	%	49.1	51.6	52.9	51.6	32.5	33.6	31.8	26.6	38.0	40.9	44.2	39.2	
	CO ₂	%	32.0	38.6	39.6	37.1	27.0	28.5	25.9	23.9	32.0	32.8	33.1	31.4	
	O ₂	%	1.9	1.4	0.0	1.0	3.3	1.8	2.6	4.4	0.9	0.7	4.9	1.2	
	BAL (N ₂)	%	17.0	8.4	7.5	10.3	37.2	36.2	39.7	45.0	29.1	25.5	17.7	28.2	
	CO	PPM	9	10	9	8	9	11	11	10	11	13	9	12	
	H ₂ S	PPM	17	19	22	18	10	17	11	4	7	5	7	8	
	Vel Max	m/s	Frozen	-	-	-	0.86	0.75	0.00	0.57	0.00	1.14	0.00	0.00	
	Vel Min	m/s	Frozen	-	-	-	1.11	0.97	0.00	0.92	0.00	1.28	0.00	0.00	
	Flow	CFM	-	-	-	-	9.307695938	7.654044375	0	7.039830938	0	11.43381938	0	0	
	Temp	°C	Surging	-	-	-	21.7	36.4	31.5	32.7	20.4	21.0	14.9	5.6	
	Comments		1/2->1T	1T	1T	1T	1T->1/2	1/2->cracked	cracked	1/2T	Cracked	Cracked	Cracked	Cracked	
	H-2	Well	"H ₂ O	-0.86	0.09	0.92	-3.14	-6.50	-5.30	-5.38	-5.54	-3.78	-3.82	-0.43	-0.12
		Lateral	"H ₂ O	-1.63	-5.23	-4.96	-5.98	-7.90	-8.62	-6.54	-5.75	-10.56	-9.27	-12.58	-12.57
CH ₄		%	58.0	54.9	55.9	54.5	47.3	52.0	44.9	45.0	46.3	37.4	34.9	43.1	
CO ₂		%	39.2	32.4	37.4	35.1	35.8	38.1	24.8	35.7	36.3	29.6	25.7	34.6	
O ₂		%	0.0	3.4	2.4	1.6	1.7	0.1	1.4	0.0	0.2	36.0	3.3	0.5	
BAL (N ₂)		%	2.7	9.3	4.3	8.8	15.1	9.8	28.9	19.2	17.2	29.3	36.0	21.8	
CO		PPM	8	6	4	2	9	12	15	13	11	11	6	10	
H ₂ S		PPM	12	12	13	15	8	13	10	15	9	14	4	5	
Vel Max		m/s	3.25	-	-	-	2.94	3.58	1.56	1.41	5.81	1.11	-	-	
Vel Min		m/s	3.64	-	-	-	3.70	3.98	1.63	1.63	6.24	1.44	-	-	
Flow		CFM	32.55331219	-	-	-	31.3721325	35.71887375	16.20578531	14.363145	56.93286094	12.04803281	-	-	
Temp		°C	11.6	-	-	-	24.5	32.2	34.5	33.3	25.2	22.6	-	-	
Comments			1->2T	2T	2T	2T	2T->1T	1T	1/2T	1/2T	1	1-> cracked	closed	closed	
H-3		Well	"H ₂ O	5.04	-2.34	-1.85	-3.02	-6.04	-8.23	-5.96	-6.83	-7.95	-6.41	-0.76	-0.12
		Lateral	"H ₂ O	-9.07	-6.12	-5.14	-5.04	-7.27	-8.44	-6.98	-6.90	-9.77	-8.72	-11.91	-9.77
	CH ₄	%	57.3	56.6	50.6	51.2	57.2	54.4	46.2	45.5	44.4	31.2	44.8	45.1	
	CO ₂	%	42.7	39.6	40.2	39.9	40.5	40.4	33.6	34.8	34.4	24.8	41.4	33.9	
	O ₂	%	0.0	2.8	3.6	2.5	0.4	0.4	2.4	2.9	3.1	6.7	13.7	2.1	
	BAL (N ₂)	%	0.0	1.0	5.6	6.4	1.8	4.8	17.8	16.8	18.1	37.3	0.1	18.9	
	CO	PPM	10	14	13	12	20	33	30	26	30	16	7	9	
	H ₂ S	PPM	9	15	16	15	15	7	10	8	6	4	14	10	
	Vel Max	m/s	-	-	-	-	0.87	1.08	1.02	0.91	1.14	-	-	-	
	Vel Min	m/s	-	-	-	-	2.46	1.37	1.65	1.32	1.30	-	-	-	
	Flow	CFM	-	-	-	-	15.73331344	11.57556094	12.61499906	10.53612281	11.52831375	-	-	-	
	Temp	°C	-	-	-	-	18.2	35.3	31.9	30.0	20.4	-	-	-	
	Comments		Frozen	1T	1T	1T	1T->2T	2T	1T	1T	1T	1T-> closed	closed	closed	
	H-4 DP	Well	"H ₂ O	3.52	0.02	0.09	-1.59	-6.29	-5.34	-3.42	-4.83	-8.70	-8.22	-8.43	-0.15
		Lateral	"H ₂ O	-8.23	-5.65	-5.94	-5.87	-7.13	-8.17	-6.87	-7.03	-9.14	-8.55	-12.00	-11.97
CH ₄		%	57.5	58.8	57.9	56.9	47.7	53.0	51.5	52.7	52.3	41.6	42.3		
CO ₂		%	42.4	20.1	42.1	41.5	34.6	38.7	34.9	35.5	38.8	37.3	30.8	35.1	
O ₂		%	0.0	4.6	0.0	1.0	2.8	0.7	1.5	1.1	1.1	1.7	4.8	2.3	
BAL (N ₂)		%	0.0	16.5	0.0	0.6	14.9	7.5	12.1	7.5	7.8	10.8	22.8	20.3	
CO		PPM	7	5	5	3	3	13	10	11	15	13	6	9	
H ₂ S		PPM	25	24	20	25	11	28	36	46	27	22	7	14	
Vel Max		m/s	-	-	-	-	1.38	1.32	1.24	1.00	1.51	2.40	0.00	0.00	
Vel Min		m/s	-	-	-	-	1.46	1.44	1.69	1.21	1.52	2.90	0.00	0.00	
Flow		CFM	-	-	-	-	13.41820125	13.04022375	13.84342594	10.44162844	14.31589781	25.04100938	0	0	
Temp		°C	-	-	-	-	18.4	28.4	30.9	32.5	22.3	25.2	13.4	5.9	
Comments			Frozen	2T	2T	2T	2T->1T	1T	1T	2T	2T	2T	cracked	cracked	

Table 2: Wellfield Monitoring Data

Units			13/Jan/20	20/Feb/20	22/Mar/20	25/Apr/20	20/May/20	20/Jun/20	20/Jul/20	24/Aug/20	27/Sep/20	28/Oct/20	28/Nov/20	16/Dec/20
1-5 well bore seal	Well	"H ₂ O	2.94	0.21	-1.38	-1.84	-1.53	-5.96	-3.65	-3.31	0.22	-0.06	-0.11	-0.07
	Lateral	"H ₂ O	-8.68	-4.62	-4.62	-5.14	-7.24	-8.57	-6.56	-6.90	-11.56	-8.14	-14.65	-12.39
	CH ₄	%	59.1	47.6	44.2	51.3	57.6	49.3	24.8	22.0	58.3	50.9	22.2	28.9
	CO ₂	%	40.6	22.6	39.3	44.1	39.5	38.7	18.2	17.9	41.0	39.1	19.0	36.0
	O ₂	%	0.2	9.8	9.9	0.5	0.6	0.7	8.6	9.5	0.0	0.5	10.6	1.0
	BAL (N ₂)	%	0.0	20.0	6.6	4.1	2.2	12.0	48.4	50.6	0.7	9.5	48.2	34.1
	CO	PPM	3	2	3	3	6	10	11	13	8	14	9	11
	H ₂ S	PPM	24	12	14	15	30	11	5	3	73	6	2	8
	Vel Max	m/s	-	-	-	-	4.35	3.14	-	-	1.24	-	-	-
	Vel Min	m/s	-	-	-	-	4.54	3.85	-	-	1.57	-	-	-
	Flow	CFM	-	-	-	-	42.00274969	33.02578406	-	-	13.27645969	-	-	-
	Temp	°C	-	-	-	-	19.9	34.6	-	-	25.3	-	-	-
	Comments		Frozen	1/2T	1/2T	1/2T	1/2T -> 1T	1T	Closed	Closed	cracked	cracked	closed	closed
	1-6 DP	Well	"H ₂ O	-2.92	1.98	2.04	1.34	0.69	-1.28	0.24	0.11	-1.21	-0.97	0.20
Lateral		"H ₂ O	-8.84	-5.34	-5.22	-6.21	-7.31	-8.57	-6.41	-7.11	-10.78	-10.66	-15.26	-12.54
CH ₄		%	33.1	32.4	38.2	39.5	59.9	32.1	40.1	57.1	36.1	22.3	40.3	42.9
CO ₂		%	22.5	36.8	32.4	35.1	38.8	26.8	31.8	39.0	28.5	15.3	27.1	25.1
O ₂		%	8.8	16.0	14.3	15.9	0.1	3.7	1.5	0.7	4.0	9.1	6.0	3.8
BAL (N ₂)		%	35.6	14.8	15.1	9.5	0.2	37.4	26.6	3.2	31.4	53.3	26.6	28.2
CO		PPM	4	5	6	8	5	8	5	7	7	7	2	6
H ₂ S		PPM	16	92	95	100	100	2	102	246	41	12	45	44
Vel Max		m/s	-	-	-	-	0.84	-	-	1.04	1.53	-	-	-
Vel Min		m/s	-	-	-	-	0.88	-	-	1.39	1.62	-	-	-
Flow		CFM	-	-	-	-	8.12651625	-	-	11.48106656	14.88286406	-	-	-
Temp		°C	-	-	-	-	22.7	-	-	36.3	27.3	-	-	-
Comments			1->closed	closed	closed	closed	closed -> cracked	cracked->closed	closed	cracked	cracked	closed	closed	closed
1-7		Well	"H ₂ O	0.43	-3.02	-1.46	-0.94	0.03	-1.76	-0.74	-0.08	-1.09	-0.23	-1.64
	Lateral	"H ₂ O	-8.51	-5.93	-6.47	-6.21	-6.76	-8.39	-6.74	-7.07	-9.42	-7.78	-14.09	-12.98
	CH ₄	%	55.4	46.2	46.9	51.1	56.0	31.9	48.7	51.2	33.9	45.0	31.9	33.3
	CO ₂	%	44.6	31.4	23.9	30.5	43.6	33.4	36.8	40.2	33.9	38.0	28.8	31.6
	O ₂	%	0.0	4.8	3.2	5.1	0.1	0.6	0.7	1.2	0.6	0.7	5.9	0.7
	BAL (N ₂)	%	0.0	17.6	26.0	13.3	0.2	34.0	13.8	7.4	31.6	16.3	33.4	34.4
	CO	PPM	93	42	40	55	91	268	105	78	69	55	47	75
	H ₂ S	PPM	7	16	16	21	19	20	25	29	28	14	32	30
	Vel Max	m/s	-	-	-	-	6.94	1.05	1.89	2.30	5.91	3.44	-	-
	Vel Min	m/s	-	-	-	-	7.24	1.11	2.24	2.40	6.02	3.71	-	-
	Flow	CFM	-	-	-	-	66.99651188	10.2053925	19.51308844	22.20617813	56.36589469	33.78173906	-	-
	Temp	°C	-	-	-	-	25.0	35.7	26.9	25.4	26.0	23.7	-	-
	Comments		Frozen	1/2T	1/2T	1/2T	1/2T -> 1T	1->cracked	1T	1T	1/2T	1/2T	closed	closed
	1-8	Well	"H ₂ O	-1.77	-3.41	-3.93	-4.28	-0.01	-1.78	-1.63	-1.54	-3.40	-0.66	-0.02
Lateral		"H ₂ O	-8.68	-5.56	-5.36	-6.17	-7.47	-8.34	-7.15	-7.23	-9.28	-8.73	-15.84	-11.59
CH ₄		%	56.4	51.3	48.9	51.2	52.0	42.1	52.6	54.0	32.3	20.5	40.9	41.2
CO ₂		%	41.5	29.6	26.4	30.4	38.1	36.9	40.5	41.4	27.0	16.4	30.6	27.0
O ₂		%	0.3	2.9	1.9	3.8	2.6	1.2	3.4	2.8	6.0	11.1	5.7	6.5
BAL (N ₂)		%	1.7	16.2	22.8	14.6	7.4	19.9	3.5	1.9	34.7	52.0	22.8	25.3
CO		PPM	9	10	11	12	26	14	15	18	12	0	12	13
H ₂ S		PPM	22	40	42	45	33	76	80	73	46	16	60	55
Vel Max		m/s	6.86	-	-	-	1.00	1.03	1.14	1.16	1.60	-	-	-
Vel Min		m/s	7.28	-	-	-	1.09	1.04	1.59	1.24	2.01	-	-	-
Flow		CFM	66.80752313	-	-	-	9.874662188	9.780167813	12.89848219	11.339325	17.05623469	-	-	-
Temp		°C	1.5	-	-	-	31.8	36.7	28.6	24.5	29.7	-	-	-
Comments			1T	1T	1T	1T	1T -> cracked	cracked	1T	1T	1/2T	closed	closed	closed
1-9 DP		Well	"H ₂ O	-5.49	-2.24	-2.02	-3.75	-6.09	-6.31	-3.69	-4.16	-5.25	-0.94	-0.31
	Lateral	"H ₂ O	-9.05	-5.92	-5.10	-6.15	-7.61	-8.45	-7.14	-7.88	-11.31	-10.55	-15.53	-11.37
	CH ₄	%	52.6	52.5	46.1	48.2	40.8	46.3	36.4	33.5	27.5	39.9	46.2	44.2
	CO ₂	%	36.7	28.6	28.6	30.6	28.9	33.9	31.7	28.7	25.9	29.6	29.2	25.3
	O ₂	%	0.2	9.2	7.6	9.8	4.4	1.4	1.9	2.5	4.0	2.4	4.0	3.6
	BAL (N ₂)	%	10.6	9.7	17.7	11.4	26.0	18.3	30.0	35.4	42.6	28.1	3.0	26.9
	CO	PPM	8	6	7	5	6	10	25	35	45	19	12	15
	H ₂ S	PPM	16	15	16	14	11	21	10	4	3	7	18	9
	Vel Max	m/s	4.25	-	-	-	1.02	1.15	0.84	0.61	0.00	-	-	-
	Vel Min	m/s	5.17	-	-	-	1.09	1.27	0.95	0.83	0.00	-	-	-
	Flow	CFM	44.50685063	-	-	-	9.969156563	11.43381938	8.457246563	6.803595	0	-	-	-
	Temp	°C	26.5	-	-	-	28.7	35.5	31.0	33.4	0.0	-	-	-
	Comments		1T	1T	1T	1T	1T -> 1/2T	1/2T	cracked	cracked	closed	closed	closed	closed

Table 2: Wellfield Monitoring Data

		Units	13/Jan/20	20/Feb/20	22/Mar/20	25/Apr/20	20/May/20	20/Jun/20	20/Jul/20	24/Aug/20	27/Sep/20	28/Oct/20	28/Nov/20	16/Dec/20
1-10 DP	Well	"H ₂ O	0.15	0.06	-2.43	-5.21	-7.78	-7.28	-3.50	-5.13	-3.21	0.01	-0.10	0.31
	Lateral	"H ₂ O	Frozen	-6.01	-4.74	-6.43	-7.96	-8.17	-7.20	-7.61	-11.15	-10.03	-16.14	-12.43
	CH ₄	%	63.9	58.6	56.9	54.8	36.1	29.5	35.2	36.4	17.6	65.2	2.1	8.7
	CO ₂	%	30.4	35.9	32.8	31.9	29.2	26.2	28.3	29.2	12.9	31.0	1.8	13.6
	O ₂	%	0.3	5.5	0.0	2.6	3.5	2.7	1.3	1.0	11.1	0.0	19.3	8.2
	BAL (N ₂)	%	5.4	0.0	0.0	10.7	31.2	41.6	35.2	33.4	58.4	3.8	76.8	69.5
	CO	PPM	3	12	13	10	9	14	18	15	5	11	3	3
	H ₂ S	PPM	2	14	14	15	2	4	5	7	1	6	0	3
	Vel Max	m/s	-	-	-	-	1.06	1.13	0.69	0.85	0.00	0.00	-	-
	Vel Min	m/s	-	-	-	-	1.37	1.22	0.85	1.06	0.00	0.00	-	-
	Flow	CFM	-	-	-	-	11.48106656	11.10308906	7.276066875	9.024212813	0	0	-	-
	Temp	°C	-	-	-	-	22.1	31.4	30.8	31.1	0.0	28.6	-	-
	Comments		Frozen	2T	2T	2T	2T -> 1T	1->1/2T	cracked	cracked	closed	cracked	closed	closed
H-11 DP	Well	"H ₂ O	-8.33	-2.12	-3.25	-2.96	-5.95	-6.56	-5.24	-5.76	-9.40	0.80	-0.02	-9.40
	Lateral	"H ₂ O	-8.81	-4.92	-4.93	-6.84	-7.01	-8.36	-6.74	-6.98	-9.46	-8.57	-12.00	-11.58
	CH ₄	%	52.0	57.2	49.5	50.2	51.1	52.2	49.2	49.5	51.1	53.7	35.3	36.9
	CO ₂	%	35.8	38.9	28.6	31.6	37.3	39.2	38.6	36.9	36.7	40.1	32.7	35.4
	O ₂	%	2.5	3.9	4.6	5.0	1.9	0.8	1.4	2.2	1.7	1.1	2.7	1.0
	BAL (N ₂)	%	9.7	0.0	17.3	13.2	9.7	7.7	10.8	11.5	10.5	5.1	29.3	26.7
	CO	PPM	1	2	4	2	1	5	5	6	9	10	5	10
	H ₂ S	PPM	29	67	65	69	78	110	127	131	78	44	67	63
	Vel Max	m/s	1.81	-	-	-	1.00	1.11	1.24	0.97	0.78	1.24	-	-
	Vel Min	m/s	1.97	-	-	-	1.14	1.29	1.98	1.07	0.89	1.31	-	-
	Flow	CFM	17.85943688	-	-	-	10.11089813	11.339325	15.21359438	9.63842625	7.890280313	12.04803281	-	-
	Temp	°C	-0.6	-	-	-	23.7	28.1	29.5	26.4	23.3	19.4	-	-
	Comments		1T	1T	1T	1T	1T	1T	1T	1T	1T	1T	closed	closed
H-12 well bore seal	Well	"H ₂ O	Frozen	?	-3.19	-3.69	-	-8.34	-5.89	-5.11	-0.38	0.98	-0.59	-1.20
	Lateral	"H ₂ O	-8.11	-6.10	-6.12	-6.22	-6.81	-9.16	-6.52	-6.87	-9.32	-8.36	-10.87	-11.67
	CH ₄	%	22.7	43.8	47.3	48.6	36.1	55.6	48.6	45.7	46.9	43.8	48.7	47.0
	CO ₂	%	13.6	28.0	32.5	30.5	24.2	35.6	33.2	31.8	35.7	33.3	32.5	33.3
	O ₂	%	14.4	6.4	8.3	9.7	7.0	1.0	2.7	3.3	1.3	0.9	0.6	1.5
	BAL (N ₂)	%	49.2	21.7	11.9	11.2	32.6	7.8	15.5	19.3	16.1	22.0	18.2	18.2
	CO	PPM	1	0	1	2	2	19	9	7	9	0	5	8
	H ₂ S	PPM	9	9	9	8	19	42	38	35	28	10	15	25
	Vel Max	m/s	-	-	-	-	0.74	3.56	0.98	0.70	0.79	0.00	0.44	0.55
	Vel Min	m/s	-	-	-	-	0.75	3.88	1.34	0.81	0.81	0.00	0.52	0.97
	Flow	CFM	-	-	-	-	7.039830938	35.1519075	10.9613475	7.134325313	7.55955	0	4.53573	7.1815725
	Temp	°C	-	-	-	-	25.4	32.1	30.1	23.5	19.9	19.6	-	-
	Comments		20%	20%	20%	20%	20% -> 10%	10->20%	20%	20%	20%	15%	15%	15%
2-13	Well	"H ₂ O	-6.56	-6.02	-3.24	-4.33	-5.63	-8.82	-3.97	1.83	-8.75	-7.23	-6.49	-7.40
	Lateral	"H ₂ O	-6.59	-6.40	-5.11	-6.10	-6.36	-9.18	-7.63	-7.83	-10.25	-8.31	-11.95	-12.37
	CH ₄	%	58.6	57.6	59.8	58.2	57.4	55.9	55.1	58.4	55.9	55.7	55.1	53.2
	CO ₂	%	41.0	42.3	29.9	35.1	39.5	38.6	36.4	41.4	40.7	39.7	38.6	39.6
	O ₂	%	0.4	0.0	10.3	1.2	0.6	0.5	0.8	0.0	3.0	0.3	3.4	3.1
	BAL (N ₂)	%	0.0	0.0	0.0	5.5	2.5	5.0	7.7	0.2	0.4	4.3	2.9	4.1
	CO	PPM	60	84	85	98	72	188	136	100	47	41	35	45
	H ₂ S	PPM	89	40	42	45	70	135	147	336	109	54	43	60
	Vel Max	m/s	-	-	-	-	2.22	2.51	3.68	5.12	3.75	2.84	3.84	3.64
	Vel Min	m/s	-	-	-	-	3.11	2.74	4.16	5.43	4.26	4.31	4.17	4.17
	Flow	CFM	-	-	-	-	25.18275094	24.80477344	37.041795	49.84578281	37.84499719	30.47443594	38.50645781	36.9005344
	Temp	°C	-	-	-	-	29.4	25.6	20.4	29.2	21.4	25.4	11.6	9.5
	Comments		2T	2T	2T	2T	2T	2T	2T	2T	2T	2T	2T	2T
2-14 well bore seal	Well	"H ₂ O	-0.05	-1.23	-1.62	-1.45	0.63	-0.75	2.45	-1.32	-1.01	-0.14	-0.23	-0.11
	Lateral	"H ₂ O	-7.06	-5.24	-5.69	-5.32	-5.33	-9.40	-6.29	-6.29	-10.44	-8.85	-10.48	-11.67
	CH ₄	%	47.2	49.6	46.4	50.6	58.8	54.8	42.5	40.0	39.3	30.0	58.1	50.1
	CO ₂	%	33.3	50.4	26.4	41.0	41.3	40.0	35.2	34.3	32.9	22.9	40.6	31.5
	O ₂	%	4.4	0.0	9.4	5.1	0.0	0.0	0.9	0.6	2.4	8.2	1.3	1.4
	BAL (N ₂)	%	15.1	0.0	17.8	3.3	0.0	5.2	21.4	25.2	25.4	38.9	0.0	17.0
	CO	PPM	5	6	5	5	6	24	28	30	17	10	10	12
	H ₂ S	PPM	34	40	41	39	38	48	36	27	20	16	25	19
	Vel Max	m/s	-	-	-	-	2.25	4.60	2.45	-	-	-	-	-
	Vel Min	m/s	-	-	-	-	2.54	5.11	3.58	-	-	-	-	-
	Flow	CFM	-	-	-	-	22.63140281	45.87701906	28.49005406	-	-	-	-	-
	Temp	°C	-	-	-	-	29.1	33.6	31.4	-	22.4	22.4	-	-
	Comments		1/2T	1/2T	1/2T	1/2T	1/2T	1/2->1T	1/2T	1/2T	cracked	closed	closed	closed

Table 2: Wellfield Monitoring Data

Units		13/Jan/20	20/Feb/20	22/Mar/20	25/Apr/20	20/May/20	20/Jun/20	20/Jul/20	24/Aug/20	27/Sep/20	28/Oct/20	28/Nov/20	16/Dec/20	
2-15	Well	"H ₂ O	-2.31	-2.02	-2.42	-1.68	-0.73	-3.39	-1.24	-0.98	-1.08	-2.67	-1.95	-1.08
	Lateral	"H ₂ O	-6.6	-6.0	-4.9	-5.1	-5.8	-9.2	-7.1	-6.8	-10.7	-9.0	-12.7	-11.0
	CH ₄	%	49.2	50.1	44.2	48.6	58.3	46.5	47.5	47.7	50.4	37.1	44.6	43.2
	CO ₂	%	36.5	49.9	32.7	35.9	40.1	37.2	36.0	37.0	37.8	30.6	33.3	35.3
	O ₂	%	0.8	0.0	5.3	2.1	0.3	0.3	0.6	1.0	1.2	3.4	4.7	1.4
	BAL (N ₂)	%	3.5	0.0	17.8	13.4	1.3	16.1	15.9	14.3	10.6	28.9	17.4	20.1
	CO	PPM	29.0	14.0	10.0	11.0	20.0	91.0	26.0	24.0	11.0	22.0	13.0	10.0
	H ₂ S	PPM	6.0	21.0	18.0	16.0	10.0	12.0	13.0	12.0	9.0	6.0	10.0	12.0
	Vel Max	m/s	-	-	-	-	3.9	2.9	1.2	-	5.6	0.0	0.6	0.4
	Vel Min	m/s	-	-	-	-	4.6	3.0	1.5	-	6.0	0.0	0.8	0.7
	Flow	CFM	-	-	-	-	40.16010938	28.11207656	12.94572938	-	54.99572625	0	6.850842188	5.149943438
	Temp	°C	-	-	-	-	23.4	25.3	26.1	-	21.4	21.8	9.6	6.3
	Comments		1->1/2T	1/2T	1/2T	1/2T	1/2->1T	1->1/2T	1/2T	1/2T	1	cracked	1/2T	1/2T
	2-16	Well	"H ₂ O	-1.43	-1.64	-3.14	-2.46	0.07	-4.39	-2.69	-3.49	0.05	-0.08	-7.34
Lateral		"H ₂ O	-6.03	-5.19	-4.22	-5.87	-6.49	-8.18	-6.84	-5.10	-9.46	-8.50	-12.22	-11.76
CH ₄		%	34.2	51.2	42.9	48.3	56.2	39.2	25.6	26.2	58.0	52.9	57.3	54.1
CO ₂		%	26.2	48.8	38.5	40.3	41.4	33.1	25.3	22.8	41.8	39.0	41.6	39.0
O ₂		%	6.8	0.0	2.2	2.5	1.7	1.7	5.4	6.9	0.0	1.5	1.1	1.3
BAL (N ₂)		%	32.7	0.0	16.4	8.9	0.0	26.0	43.7	44.7	0.2	6.6	0.0	5.6
CO		PPM	5	5	6	7	10	36	10	1	18	9	12	15
H ₂ S		PPM	16	17	15	14	20	21	16	14	48	17	18	50
Vel Max		m/s	-	-	-	-	3.90	8.13	0.00	-	4.51	6.39	0.00	2.65
Vel Min		m/s	-	-	-	-	4.60	8.33	0.00	-	4.84	7.11	0.00	2.97
Flow		CFM	-	-	-	-	40.16010938	77.76887063	0	-	44.17612031	63.78370313	0	26.55291938
Temp		°C	-	-	-	-	23.4	31.5	30.6	-	24.7	24.1	4.9	2.5
Comments			2->1/2T	1-2T	1/2T	1/2T	1/2->1T	1->1/2T	cracked	cracked	1/2T	1/2T	1/2T	1/2T
2-17		Well	"H ₂ O	-2.35	-1.29	-1.92	-2.10	-2.55	-7.13	-4.27	-2.93	-3.87	-2.84	-0.67
	Lateral	"H ₂ O	-6.63	-4.63	-3.86	-5.68	-6.28	-9.44	-6.63	-7.41	-10.31	-9.69	-12.68	-10.58
	CH ₄	%	55.5	55.4	43.2	50.3	59.5	46.1	48.6	49.8	50.8	40.5	49.0	44.8
	CO ₂	%	36.5	30.2	36.1	41.5	40.3	37.0	35.2	37.9	38.4	30.6	34.6	36.2
	O ₂	%	1.0	14.0	12.4	6.5	0.2	0.2	0.8	0.6	0.7	4.3	3.0	1.3
	BAL (N ₂)	%	4.9	0.4	8.3	1.7	0.0	16.7	15.4	11.7	10.1	24.6	13.4	17.7
	CO	PPM	7	2	3	3	8	15	10	9	7	6	3	8
	H ₂ S	PPM	6	8	9	8	8	7	5	3	5	3	4	8
	Vel Max	m/s	-	-	-	-	4.04	3.94	1.39	-	5.31	0.00	0.00	0.00
	Vel Min	m/s	-	-	-	-	4.38	4.13	2.11	-	5.96	0.00	0.00	0.00
	Flow	CFM	-	-	-	-	39.78213188	38.12848031	16.53651563	-	53.24758031	0	0	0
	Temp	°C	-	-	-	-	22.5	26.2	29.3	-	19.5	28.4	14.3	3.6
	Comments		1T	1T	1T	1T	1->2T	2->1T	1T	1T	1T	cracked	cracked	cracked
	2-18	Well	"H ₂ O	0.11	0.14	0.94	0.32	-0.52	-0.97	-0.87	-0.98	-0.41	-0.26	0.16
Lateral		"H ₂ O	-6.50	-4.82	-4.20	-6.03	-8.36	-8.97	-7.20	-7.25	-11.34	-9.51	-15.62	-11.36
CH ₄		%	43.7	39.7	36.2	35.6	34.2	6.9	18.4	24.3	39.1	41.6	59.4	35.6
CO ₂		%	35.0	38.8	29.4	32.5	31.0	11.3	25.3	26.6	33.7	33.7	38.0	33.5
O ₂		%	0.6	20.5	23.4	6.5	2.1	9.6	2.4	1.7	0.2	0.1	2.6	0.6
BAL (N ₂)		%	20.6	1.0	11.0	25.4	32.7	72.2	53.9	47.4	27.0	24.6	0.0	30.3
CO		PPM	6	5	5	4	14	18	15	20	7	13	9	8
H ₂ S		PPM	10	12	13	14	0	1	14	11	39	26	29	25
Vel Max		m/s	-	-	-	-	-	-	-	-	-	-	0.00	-
Vel Min		m/s	-	-	-	-	-	-	-	-	-	-	0.00	-
Flow		CFM	-	-	-	-	-	-	-	-	-	-	0	-
Temp		°C	-	-	-	-	-	-	-	-	-	-	10.4	-
Comments			closed	closed	closed	closed	closed	closed	closed	closed	closed	closed	cracked	closed
3-19		Well	"H ₂ O	-1.59	-3.14	0.23	-1.62	-4.74	-2.45	-3.58	-4.47	-0.07	0.08	-0.09
	Lateral	"H ₂ O	-6.98	-4.31	-5.01	-5.24	-5.87	-6.12	-6.93	-6.65	-8.08	-10.39	-10.75	-12.09
	CH ₄	%	57.4	52.7	56.7	52.6	44.6	53.9	35.2	30.8	40.1	58.6	24.5	32.9
	CO ₂	%	39.5	37.1	20.2	26.3	32.3	38.4	26.7	22.7	30.1	41.3	18.4	33.6
	O ₂	%	1.1	3.3	0.0	3.5	3.7	0.9	7.1	8.3	4.8	0.0	10.4	3.9
	BAL (N ₂)	%	2.0	7.0	23.1	17.6	19.3	6.8	31.0	38.2	25.0	0.1	46.7	29.6
	CO	PPM	5	6	7	5	6	11	14	9	11	6	4	12
	H ₂ S	PPM	28	9	8	12	23	35	25	21	31	23	7	23
	Vel Max	m/s	5.45	-	-	-	4.11	5.78	2.54	2.93	2.94	6.78	-	-
	Vel Min	m/s	6.11	-	-	-	4.33	5.90	2.68	3.14	3.11	7.12	-	-
	Flow	CFM	54.61774875	-	-	-	39.87662625	55.184715	24.66303188	28.67904281	28.58454844	65.67359063	-	-
	Temp	°C	8.4	-	-	-	18.3	24.1	27.0	25.2	27.3	11.7	-	-
	Comments		2T	2T	2T	2T	2->1T	1->2T	1/2T	1/2T	cracked	1T	closed	closed

Table 2: Wellfield Monitoring Data

	Units	13/Jan/20	20/Feb/20	22/Mar/20	25/Apr/20	20/May/20	20/Jun/20	20/Jul/20	24/Aug/20	27/Sep/20	28/Oct/20	28/Nov/20	16/Dec/20	
3-20	Well	"H ₂ O	-1.20	-3.41	-3.21	-4.98	-5.37	-5.54	-6.13	-6.04	-7.93	-7.60	-9.43	-9.68
	Lateral	"H ₂ O	-6.84	-4.32	-5.85	-6.14	-6.30	-6.28	-6.93	-6.63	-8.90	-8.34	-11.36	-11.48
	CH ₄	%	56.0	56.5	58.2	55.7	52.0	55.1	55.7	56.8	55.1	54.0	54.0	53.7
	CO ₂	%	43.8	43.3	31.4	35.2	39.2	41.0	39.6	42.2	21.8	41.3	40.0	20.9
	O ₂	%	0.2	0.1	0.0	2.6	1.2	0.6	1.2	0.5	0.1	0.5	2.4	0.8
	BAL (N ₂)	%	0.0	0.0	10.4	6.5	7.6	3.3	3.5	0.6	23.0	4.2	3.6	24.6
	CO	PPM	17	19	21	20	17	23	25	27	29	17	16	15
	H ₂ S	PPM	15	3	4	5	8	6	9	6	8	5	5	9
	Vel Max	m/s	5.14	-	-	-	3.96	3.14	3.65	3.53	4.03	2.53	4.32	3.59
	Vel Min	m/s	5.24	-	-	-	5.11	3.21	3.81	3.67	4.78	3.42	4.96	4.06
	Flow	CFM	49.04258063	-	-	-	42.85319906	30.00196406	35.24640188	34.017975	41.62477219	28.11207656	43.84539	36.14409844
	Temp	°C	4.2	-	-	-	18.6	24.1	25.2	24.7	19.7	17.6	9.3	5.3
	Comments		2T	2T	2T	2T	2T	2T	2T	2T	2T	2T	2T	2T
	3-21	Well	"H ₂ O	-0.59	-2.15	1.20	1.65	-5.01	-4.00	-1.14	1.39	0.77	-1.36	0.02
Lateral		"H ₂ O	-6.57	-5.03	-5.26	-6.58	-7.42	-6.37	-6.58	-7.39	-9.24	-8.12	-11.83	-9.24
CH ₄		%	51.6	5.2	8.7	23.6	55.6	25.8	34.2	37.1	54.0	19.0	35.6	37.5
CO ₂		%	45.8	3.7	6.3	5.6	41.8	20.9	24.3	28.8	43.8	16.4	28.6	30.6
O ₂		%	1.8	20.6	21.9	25.1	0.3	9.6	6.9	5.3	0.1	11.8	8.3	4.2
BAL (N ₂)		%	0.8	70.5	63.9	45.7	2.3	43.6	34.6	29.8	2.1	52.8	27.5	27.7
CO		PPM	5	2	3	2	4	5	11	9	10	5	4	8
H ₂ S		PPM	15	0	0	2	27	0	26	53	38	1	9	22
Vel Max		m/s	-	-	-	-	0.47	-	-	-	0.00	-	-	-
Vel Min		m/s	-	-	-	-	0.56	-	-	-	0.00	-	-	-
Flow		CFM	-	-	-	-	4.866460313	-	-	-	0	-	-	-
Temp		°C	-	-	-	-	28.7	-	-	-	22.5	-	-	-
Comments			1T	1T->closed	closed	closed	closed->cracked	cracked->closed	closed	closed	cracked	closed	closed	closed
3-22		Well	"H ₂ O	-5.40	-3.21	-2.95	-4.58	-3.34	-4.26	-1.60	3.19	-2.45	-3.66	-5.24
	Lateral	"H ₂ O	-6.47	-3.95	-5.23	-5.24	-4.89	-6.11	-6.75	-7.22	-9.78	-7.91	-11.24	-11.97
	CH ₄	%	57.2	58.0	60.2	56.7	55.8	45.8	57.4	60.0	55.7	57.3	55.2	53.6
	CO ₂	%	42.7	41.5	39.2	36.8	39.3	32.2	36.1	39.4	36.4	41.2	40.2	38.4
	O ₂	%	0.0	0.4	0.6	1.4	0.9	3.8	1.3	0.0	0.4	0.8	2.3	1.8
	BAL (N ₂)	%	0.0	0.0	0.0	5.1	4.1	18.3	5.2	0.6	7.5	0.7	2.3	6.2
	CO	PPM	24	31	32	25	36	48	15	12	10	20	18	15
	H ₂ S	PPM	25	26	26	36	48	50	254	500	480	29	19	33
	Vel Max	m/s	-	1.93	-	-	4.67	1.64	2.56	3.82	1.56	3.41	1.96	1.68
	Vel Min	m/s	-	1.53	-	-	5.05	1.69	2.71	4.14	2.14	3.86	2.23	2.06
	Flow	CFM	-	16.34752688	-	-	45.92426625	15.73331344	24.89926781	37.60876125	17.48145938	34.34870531	19.79657156	17.67044813
	Temp	°C	-	13.4	-	-	28.0	24.8	26.2	24.2	25.9	22.9	13.0	6.2
	Comments		2T	2T	2T	2T	2T	2->1/2T	1/2T	1/2T	1/2T	1T	1T	1T
	3-23	Well	"H ₂ O	frozen	-3.16	1.59	-2.58	-3.16	-4.44	TOO	TOO	TOO	Too Tall	-9.68
Lateral		"H ₂ O	-6.45	-3.47	-3.49	-4.24	-4.37	-4.62	TALL	TALL	TALL	-9.32	-12.48	-11.03
CH ₄		%	58.7	59.0	57.4	56.4	58.0	51.8	-	-	-	58.0	52.3	51.7
CO ₂		%	41.3	40.8	37.6	38.5	39.2	35.4	-	-	-	39.3	36.1	35.7
O ₂		%	1.0	0.2	1.3	1.1	0.3	2.0	-	-	-	0.9	6.0	3.8
BAL (N ₂)		%	0.0	0.0	3.9	4.0	2.5	10.9	-	-	-	1.8	5.6	8.8
CO		PPM	4	5	6	5	19	17	-	-	-	6	7	12
H ₂ S		PPM	53	56	50	66	86	83	-	-	-	34	25	31
Vel Max		m/s	-	0.00	-	-	0.72	0.61	-	-	-	0.89	1.15	1.06
Vel Min		m/s	-	0.00	-	-	1.29	1.14	-	-	-	1.47	1.37	1.35
Flow		CFM	-	0	-	-	9.496684688	8.268257813	-	-	-	11.15033625	11.90629125	11.38657219
Temp		°C	-	6.2	-	-	26.7	30.5	-	-	-	11.6	12.9	3.0
Comments			2T	2T	2T	2T	2T	2T	2T	2T	2T	2T	2T	2T
3-24		Well	"H ₂ O	-0.96	-0.65	0.06	0.08	0.04	0.03	0.05	0.00	-0.54	-0.49	-0.02
	Lateral	"H ₂ O	-6.94	-4.22	-4.24	-4.52	-5.08	-6.39	-7.10	-7.75	-9.67	-7.40	-12.08	-12.97
	CH ₄	%	57.1	19.8	17.6	26.3	58.4	58.2	55.2	57.2	56.1	20.6	46.0	45.9
	CO ₂	%	42.9	14.1	36.2	35.1	41.5	40.8	39.8	41.6	40.8	16.0	35.9	36.5
	O ₂	%	0.0	15.5	17.6	18.6	0.2	0.1	0.3	0.0	0.1	14.1	2.5	3.6
	BAL (N ₂)	%	0.0	50.6	28.6	20.0	0.0	1.0	4.7	1.2	3.0	49.3	15.6	14.0
	CO	PPM	28	4	3	5	44	71	55	39	41	7	23	15
	H ₂ S	PPM	40	14	14	17	86	155	149	157	139	44	99	87
	Vel Max	m/s	-	-	-	-	1.36	1.69	2.56	5.82	3.47	-	-	-
	Vel Min	m/s	-	-	-	-	1.40	2.13	3.24	6.41	4.10	-	-	-
	Flow	CFM	-	-	-	-	13.04022375	18.04842563	27.40336875	57.78331031	35.76612094	-	-	-
	Temp	°C	-	-	-	-	32.0	35.6	28.4	27.1	29.4	-	-	-
	Comments		Frozen	2T->closed	closed	closed	closed->cracked	cracked->1/2T	1T	1T	1T	closed	closed	closed

Table 2: Wellfield Monitoring Data

	Units	13/Jan/20	20/Feb/20	22/Mar/20	25/Apr/20	20/May/20	20/Jun/20	20/Jul/20	24/Aug/20	27/Sep/20	28/Oct/20	28/Nov/20	16/Dec/20	
3-30 DP	Well	"H ₂ O	0.25	-2.10	-3.43	-4.05	-1.90	-2.04	-1.65	-1.34	-0.37	-0.82	-0.26	-0.14
	Lateral	"H ₂ O	-6.82	-4.79	-4.82	-4.51	-4.11	-8.41	-6.96	-6.63	-10.20	-7.70	-11.21	-11.47
	CH ₄	%	52.6	54.9	55.4	50.6	37.1	35.4	38.4	36.7	52.6	36.6	47.9	42.7
	CO ₂	%	40.5	38.7	32.6	35.6	28.3	27.9	26.7	29.7	37.8	28.8	33.1	34.1
	O ₂	%	0.4	1.3	1.4	2.5	5.3	3.6	3.6	3.5	0.7	5.0	10.8	4.8
	BAL (N ₂)	%	6.5	5.1	10.6	11.3	29.2	33.2	31.3	30.1	8.9	29.6	8.2	18.4
	CO	PPM	5	6	6	5	5	8	10	9	8	6	10	5
	H ₂ S	PPM	26	5	6	7	10	18	16	20	42	12	13	24
	Vel Max	m/s	-	-	-	-	4.04	-	-	-	2.89	-	-	-
	Vel Min	m/s	-	-	-	-	5.67	-	-	-	3.03	-	-	-
	Flow	CFM	-	-	-	-	45.87701906	-	-	-	27.970335	-	-	-
	Temp	°C	-	-	-	-	38.7	-	-	-	33.4	-	-	-
	Comments		1T	1T	1T	1T	1->1/2T	1/2->closed	closed	closed	cracked	closed	closed	closed
	4-31	Well	"H ₂ O	-3.80	-3.47	-4.11	-4.25	-3.62	-4.31	-2.47	-2.63	-4.87	-4.82	-3.49
Lateral		"H ₂ O	-4.92	-4.05	-4.92	-4.82	-3.67	-4.55	-6.69	-7.70	-9.66	-9.56	-11.48	-12.67
CH ₄		%	58.9	57.8	58.4	56.3	54.5	49.3	51.3	53.9	52.7	51.1	46.9	51.8
CO ₂		%	40.4	41.0	29.4	36.1	39.0	37.0	38.4	39.4	39.2	38.1	34.3	35.4
O ₂		%	0.7	1.1	0.0	1.3	0.8	1.3	0.9	0.6	1.4	1.3	4.8	2.5
BAL (N ₂)		%	0.0	0.0	12.2	6.3	5.7	12.1	9.4	6.1	6.7	9.5	14.0	10.3
CO		PPM	3	5	7	5	5	10	12	13	15	5	12	14
H ₂ S		PPM	47	16	20	26	62	87	85	87	95	37	16	84
Vel Max		m/s	0.79	-	-	-	4.46	2.04	2.68	3.02	2.46	4.53	2.69	2.47
Vel Min		m/s	1.09	-	-	-	5.80	2.31	3.20	3.32	3.12	5.12	2.83	3.28
Flow		CFM	8.88247125	-	-	-	48.47561438	20.55252656	27.78134625	29.95471688	26.36393063	45.59353594	26.0804475	27.16713281
Temp		°C	3.4	-	-	-	21.6	30.4	26.3	25.9	28.9	20.1	9.7	5.1
Comments			2T	2T	2T	2T	2T	2T->1T	1T	1T	1T	1T	1T	1T
4-32		Well	"H ₂ O	81.48	-4.47	-3.40	-3.67	-3.66	-5.08	-6.14	-7.86	-8.74	-9.39	-11.32
	Lateral	"H ₂ O	Frozen	-5.68	-5.04	-4.92	-4.25	-5.44	-6.94	-7.84	-9.57	-9.55	-12.02	-12.48
	CH ₄	%	56.6	56.7	57.9	56.4	56.1	55.5	52.9	53.6	54.2	56.6	48.6	54.0
	CO ₂	%	43.0	42.6	31.7	36.8	41.2	42.3	40.7	40.9	39.4	42.4	36.8	35.9
	O ₂	%	0.4	0.7	3.2	2.6	0.7	0.0	0.2	0.5	0.6	0.1	3.9	1.2
	BAL (N ₂)	%	0.0	0.0	7.2	4.2	2.1	2.1	6.2	5.0	5.8	0.9	10.7	8.9
	CO	PPM	2	5	7	5	5	8	6	24	14	5	11	12
	H ₂ S	PPM	54	22	21	25	85	159	135	113	124	53	43	39
	Vel Max	m/s	-	-	-	-	2.46	1.64	3.68	2.31	1.69	2.47	2.14	2.39
	Vel Min	m/s	-	-	-	-	2.69	1.67	4.12	2.51	2.47	2.73	2.65	3.01
	Flow	CFM	-	-	-	-	24.33230156	15.63881906	36.85280625	22.77314438	19.65483	24.5685375	22.63140281	25.51348125
	Temp	°C	-	-	-	-	26.5	30.2	26.3	25.4	27.4	13.1	10.2	5.2
	Comments		Frozen	2T	2T	2T	2T	2T	2T	2T	2T	2T	2T	2T
	4-33	Well	"H ₂ O	-6.07	-4.55	-4.88	-5.01	-5.85	-4.77	-6.32	-6.76	-7.45	-6.89	-7.44
Lateral		"H ₂ O	-7.81	-5.28	-5.69	-5.57	-5.95	-5.13	-6.97	-6.08	-9.82	-7.02	-9.67	-11.53
CH ₄		%	58.3	59.0	56.2	55.2	55.9	53.5	55.4	56.5	55.5	56.5	54.7	52.4
CO ₂		%	41.4	40.3	28.6	39.9	38.5	37.2	36.5	39.1	38.6	38.9	37.2	36.1
O ₂		%	0.2	0.7	4.7	1.3	0.9	1.4	0.6	0.4	1.3	0.8	1.8	1.2
BAL (N ₂)		%	0.0	0.0	10.5	3.6	4.6	7.8	7.5	4.0	4.6	3.8	6.4	10.3
CO		PPM	6	5	5	5	5	11	12	15	16	6	11	11
H ₂ S		PPM	408	245	255	262	269	>>>>	>>>>	>>>>	>>>>	261	461	>>>>
Vel Max		m/s	-	0.00	-	-	1.18	1.01	1.68	1.50	0.78	1.63	5.20	1.59
Vel Min		m/s	-	0.00	-	-	1.80	1.46	2.65	2.50	1.24	1.84	5.43	1.88
Flow		CFM	-	0	-	-	14.07966188	11.67005531	20.45803219	18.898875	9.543931875	16.39477406	50.22376031	16.39477406
Temp		°C	-	10.6	-	-	16.9	27.1	25.2	23.4	25.8	19.0	10.1	3.4
Comments			1T->2T	2T	2T	2T	2T	2T	2T	2T	2T	2T	2T	2T
4-34		Well	"H ₂ O	-5.54	-2.73	-3.39	-1.68	-1.52	-3.56	-1.25	0.13	0.55	1.53	-0.64
	Lateral	"H ₂ O	-7.73	-5.46	-4.64	-4.51	-4.37	-5.52	-4.31	-7.43	-8.21	-7.82	-8.18	-11.03
	CH ₄	%	43.4	45.4	52.2	51.8	44.2	37.0	37.2	38.4	35.4	59.1	7.0	13.7
	CO ₂	%	30.9	32.7	30.9	35.6	31.2	26.8	27.1	25.8	28.1	40.4	5.2	31.4
	O ₂	%	5.0	6.6	9.8	7.3	4.2	6.0	4.9	5.8	3.5	0.4	17.7	2.9
	BAL (N ₂)	%	20.7	15.3	7.1	5.3	20.4	30.2	30.8	30.0	33.0	0.1	70.1	52.0
	CO	PPM	3	3	8	6	5	5	5	6	5	5	3	5
	H ₂ S	PPM	31	82	81	102	269	404	384	357	366	176	7	240
	Vel Max	m/s	-	-	-	-	1.49	-	-	-	-	0.00	-	-
	Vel Min	m/s	-	-	-	-	1.67	-	-	-	-	0.00	-	-
	Flow	CFM	-	-	-	-	14.93011125	-	-	-	-	0	-	-
	Temp	°C	-	-	-	-	27.3	-	-	-	-	14.2	-	-
	Comments		1->1/2T	1/2T	1/2T	1/2T	1/2T	1/2T->closed	closed	closed	closed	cracked	closed	closed

Table 2: Wellfield Monitoring Data

Units		13/Jan/20	20/Feb/20	22/Mar/20	25/Apr/20	20/May/20	20/Jun/20	20/Jul/20	24/Aug/20	27/Sep/20	28/Oct/20	28/Nov/20	16/Dec/20	
5-40	Well	"H ₂ O	0.91	-5.56	-4.01	-3.68	-2.40	-5.40	-1.63	-1.14	-0.22	-8.09	-0.11	-0.15
	Lateral	"H ₂ O	-7.74	-5.95	-4.84	-4.62	-2.54	-6.09	-6.85	-7.84	-6.12	-9.76	-8.16	-11.04
	CH ₄	%	58.8	47.0	49.2	50.1	40.7	41.3	44.2	45.2	40.3	40.6	48.1	44.9
	CO ₂	%	41.1	34.5	28.4	31.9	31.2	33.2	33.9	34.6	35.8	33.0	33.5	31.6
	O ₂	%	0.1	4.0	6.4	4.0	4.3	3.0	1.2	0.5	1.0	2.7	14.8	1.1
	BAL (N ₂)	%	0.0	14.6	16.0	14.0	23.9	22.4	20.7	19.7	22.9	23.7	3.6	22.4
	CO	PPM	3	5	6	4	5	6	9	8	7	3	7	7
	H ₂ S	PPM	61	43	38	105	149	232	251	247	231	41	174	157
	Vel Max	m/s	-	-	-	-	0.71	0.64	0.00	0.00	0.12	-	-	-
	Vel Min	m/s	-	-	-	-	0.90	0.66	0.00	0.00	0.18	-	-	-
	Flow	CFM	-	-	-	-	7.606797188	6.142134375	0	0	1.417415625	-	-	-
	Temp	°C	-	-	-	-	28.8	36.4	24.2	23.4	20.3	-	-	-
	Comments		Frozen	closed->1T	1T	1T	1->1/2T	1/2->cracked	cracked	cracked	cracked	closed	closed	closed
	5-41 well bore seal	Well	"H ₂ O	-6.38	-5.04	-4.57	-4.14	-2.17	-5.03	-6.20	-6.78	-7.14	-7.58	0.12
Lateral		"H ₂ O	-6.86	-5.94	-5.12	-4.25	-2.67	-5.41	-7.62	-8.13	-8.44	-8.34	-7.39	-10.24
CH ₄		%	60.4	59.7	56.2	55.9	58.3	57.3	53.7	51.3	56.2	23.3	40.5	41.2
CO ₂		%	39.4	39.7	34.4	41.3	38.2	38.0	35.8	37.2	31.5	16.1	28.3	31.5
O ₂		%	0.2	0.5	0.0	1.0	0.2	0.3	0.8	0.7	0.3	12.2	5.4	1.0
BAL (N ₂)		%	0.0	0.0	9.4	1.8	3.3	4.4	9.7	10.8	12.0	48.4	25.8	26.3
CO		PPM	3	6	7	9	7	7	5	8	6	4	6	4
H ₂ S		PPM	41	60	50	66	179	325	354	311	324	46	69	55
Vel Max		m/s	-	-	-	-	1.65	1.78	4.98	3.16	3.01	-	-	-
Vel Min		m/s	-	-	-	-	3.49	2.10	5.21	3.82	3.22	-	-	-
Flow		CFM	-	-	-	-	24.28505438	18.33190875	48.14488406	32.97853688	29.43499781	-	-	-
Temp		°C	-	-	-	-	29.3	33.0	28.9	24.4	22.4	-	-	-
Comments			2T	2T	2T	2T	2T	2T	2T	2T	2T	closed	closed	closed
5-42		Well	"H ₂ O	-1.00	-0.55	-0.81	-1.64	0.14	-2.91	-2.89	-3.98	-2.12	-0.10	-3.84
	Lateral	"H ₂ O	-7.76	-6.85	-5.35	-4.96	-4.40	-5.75	-6.57	-7.60	-8.30	-10.28	-9.47	-10.24
	CH ₄	%	37.9	43.5	47.4	48.5	57.7	36.6	48.7	50.6	49.5	55.7	52.2	51.4
	CO ₂	%	27.6	31.7	26.9	39.7	41.0	27.2	28.5	31.4	33.2	39.6	36.9	31.0
	O ₂	%	7.4	5.6	7.5	1.5	0.0	6.0	4.6	3.4	5.4	0.6	3.5	3.9
	BAL (N ₂)	%	27.2	19.2	18.2	10.3	1.2	30.2	18.2	14.6	11.9	4.1	7.4	13.7
	CO	PPM	5	11	7	10	16	16	14	21	20	12	16	11
	H ₂ S	PPM	12	93	87	71	189	121	161	185	174	188	221	150
	Vel Max	m/s	-	-	-	-	1.93	2.63	1.54	1.18	1.05	2.52	0.44	1.25
	Vel Min	m/s	-	-	-	-	2.07	2.79	2.35	1.97	1.22	2.74	0.81	1.67
	Flow	CFM	-	-	-	-	18.898875	25.60797563	18.37915594	14.88286406	10.72511156	24.85202063	5.905898438	13.79617875
	Temp	°C	-	-	-	-	28.5	25.1	23.4	27.6	23.4	27.0	13.3	6.3
	Comments		40->30%	30%>25%	25%	25%	25->30%	30->20%	20%	20%	20%	25%	20%	20%
	5-43	Well	"H ₂ O	-4.65	-4.88	-5.24	-4.32	-3.59	-5.31	-5.77	-7.68	-8.14	-9.51	-7.45
Lateral		"H ₂ O	-5.26	-5.23	-5.72	-4.51	-4.00	-5.64	-6.91	-7.79	-8.24	-10.06	-9.01	-10.27
CH ₄		%	59.9	58.3	60.2	59.6	58.0	58.2	57.8	56.5	58.2	51.6	21.0	33.6
CO ₂		%	40.0	40.0	39.8	38.2	38.4	39.4	38.4	38.1	25.6	35.2	14.8	34.2
O ₂		%	0.1	1.7	0.0	2.2	0.3	0.1	0.5	1.6	1.0	2.2	12.9	1.9
BAL (N ₂)		%	0.0	0.0	0.0	0.0	3.3	2.2	3.3	3.9	15.2	11.0	51.3	30.3
CO		PPM	5	4	7	4	9	7	7	10	8	6	5	4
H ₂ S		PPM	66	14	10	23	65	101	92	84	102	33	19	111
Vel Max		m/s	3.30	-	-	-	2.40	2.21	3.14	2.54	3.05	2.78	-	-
Vel Min		m/s	3.40	-	-	-	3.20	3.44	3.69	3.51	3.14	3.41	-	-
Flow		CFM	31.65561563	-	-	-	26.458425	21.96994219	32.26982906	28.58454844	29.24600906	29.24600906	-	-
Temp		°C	-2.6	-	-	-	23.0	28.6	25.1	24.8	24.8	11.4	-	-
Comments			3T	3T	3T	3T	3T	3T	3T	3T	3T	3T	closed	closed
5-44		Well	"H ₂ O	0.47	-0.06	-2.79	-1.68	-0.08	-0.14	-2.35	-1.45	-2.44	-1.02	-0.75
	Lateral	"H ₂ O	-7.22	-5.43	-4.92	-4.25	-5.88	-6.13	-7.61	-7.15	-6.84	-8.48	-10.21	
	CH ₄	%	57.8	58.4	51.9	50.5	47.1	52.6	47.3	48.3	45.1	41.7	37.7	35.8
	CO ₂	%	41.9	41.2	32.6	42.0	36.4	39.3	38.1	39.3	35.4	34.6	30.7	32.5
	O ₂	%	0.3	0.3	3.9	1.2	0.5	0.3	0.2	0.0	0.9	4.3	2.5	1.8
	BAL (N ₂)	%	0.0	0.0	11.6	6.3	16.0	7.7	14.4	12.4	18.6	19.4	29.1	29.9
	CO	PPM	4	5	8	7	6	11	10	13	14	8	10	11
	H ₂ S	PPM	207	>>>>	>>>>	>>>>	186	>>>>	>>>>	>>>>	>>>>	191	226	>>>>
	Vel Max	m/s	-	0.00	-	-	2.00	1.00	1.02	1.64	1.44	0.00	-	-
	Vel Min	m/s	-	0.00	-	-	2.35	1.06	1.49	1.73	1.62	0.00	-	-
	Flow	CFM	-	0	-	-	20.55252656	9.732920625	11.85904406	15.92230219	14.45763938	0	-	-
	Temp	°C	-	6.1	-	-	20.2	35.7	24.7	29.4	28.5	10.4	-	-
	Comments		Frozen	cracked->1/2T	1/2T	1/2T	1/2->cracked	cracked->1/2T	1/2T	1/2T	1/2T	cracked	closed	closed

Table 2: Wellfield Monitoring Data

Units		13/Jan/20	20/Feb/20	22/Mar/20	25/Apr/20	20/May/20	20/Jun/20	20/Jul/20	24/Aug/20	27/Sep/20	28/Oct/20	28/Nov/20	16/Dec/20	
5-45	Well	"H ₂ O	-0.02	0.04	0.71	0.62	0.02	0.04	-0.97	-0.45	-0.22	0.03	-2.60	-1.69
	Lateral	"H ₂ O	-7.02	-4.51	-5.62	-5.24	-6.45	-	-6.49	-7.97	-7.64	-6.83	-9.88	-10.58
	CH ₄	%	46.9	34.0	35.9	45.1	54.6	58.2	33.8	35.7	31.5	57.1	50.4	51.4
	CO ₂	%	35.2	28.0	16.2	32.6	39.6	38.0	31.6	32.1	30.2	41.5	36.1	31.4
	O ₂	%	3.9	5.6	19.6	4.5	0.1	0.0	2.4	3.3	2.8	1.2	2.5	1.7
	BAL (N ₂)	%	14.0	32.4	28.3	17.8	5.8	3.8	32.2	28.9	35.5	0.2	11.0	15.5
	CO	PPM	3	3	5	1	5	9	11	14	9	7	9	10
	H ₂ S	PPM	24	25	20	69	107	260	97	72	81	145	143	77
	Vel Max	m/s	-	-	-	-	1.28	-	-	-	-	0.00	1.15	1.28
	Vel Min	m/s	-	-	-	-	1.38	-	-	-	-	0.00	1.73	1.99
	Flow	CFM	-	-	-	-	12.56775188	-	-	-	-	0	13.60719	15.44983031
	Temp	°C	-	-	-	-	17.8	-	-	-	-	17.7	11.2	5.3
	Comments		cracked	cracked->closed	closed	closed	closed->cracked	cracked->1/2T	closed	closed	closed	cracked	1/2T	1/2T
	5-46	Well	"H ₂ O	0.15	-2.69	0.03	0.24	-0.23	-1.95	-0.14	0.18	-0.04	Under Construction	0.14
Lateral		"H ₂ O	-7.92	-6.01	-5.24	-4.87	-4.76	-8.62	-6.84	-7.46	-7.95	-	-9.36	-11.47
CH ₄		%	58.8	29.8	32.6	43.3	58.5	33.0	35.3	37.4	32.8	-	59.7	48.7
CO ₂		%	41.2	24.7	19.4	24.5	40.1	26.8	30.9	31.6	35.9	-	40.3	33.9
O ₂		%	0.0	8.6	24.4	16.1	0.0	5.5	5.1	7.4	4.7	-	0.0	2.1
BAL (N ₂)		%	0.0	36.8	23.6	16.1	1.4	34.7	28.7	23.6	26.6	-	0.0	15.3
CO		PPM	3	8	6	9	6	20	22	25	18	-	12	15
H ₂ S		PPM	21	18	15	14	138	32	45	31	40	-	191	44
Vel Max		m/s	-	-	-	-	0.00	-	-	-	-	-	0.00	0.00
Vel Min		m/s	-	-	-	-	0.00	-	-	-	-	-	0.00	0.00
Flow		CFM	-	-	-	-	0	-	-	-	-	-	0	0
Temp		°C	-	-	-	-	25.8	-	-	-	-	-	10.3	5.7
Comments			Frozen	1T-> closed	closed	closed	closed->cracked	cracked->closed	closed	closed	closed	closed	cracked	cracked
6-47		Well	"H ₂ O	4.16	-5.08	-4.90	-4.63	-3.24	-4.58	-5.14	-6.87	-7.81	-7.33	-7.51
	Lateral	"H ₂ O	-5.04	-5.36	-5.15	-4.98	-3.58	-4.68	-5.39	-6.02	-7.99	-7.91	-9.14	-12.60
	CH ₄	%	60.3	56.2	57.6	55.0	56.8	56.7	54.3	51.1	54.2	50.1	56.7	54.0
	CO ₂	%	39.1	35.7	30.4	38.6	36.3	36.6	35.7	33.7	30.8	32.8	32.8	31.7
	O ₂	%	0.6	2.3	0.6	1.5	0.9	0.8	1.4	2.2	1.8	3.5	1.5	1.5
	BAL (N ₂)	%	0.0	5.8	11.4	4.9	6.1	6.0	8.6	13.0	13.2	13.6	3.6	12.8
	CO	PPM	3	4	7	8	8	6	9	9	7	4	6	5
	H ₂ S	PPM	20	6	7	10	18	31	25	24	32	13	26	22
	Vel Max	m/s	-	-	-	-	0.00	0.00	0.00	0.00	0.00	Surging	4.13	2.47
	Vel Min	m/s	-	-	-	-	0.00	0.00	0.00	0.00	0.00	-	4.99	3.11
	Flow	CFM	-	-	-	-	0	0	0	0	0	-	43.089435	26.36393063
	Temp	°C	-	-	-	-	31.0	34.5	21.3	26.5	23.8	-	10.1	5.4
	Comments		Frozen	2T	2T	2T	2T	2T	2T	2T	2T	2T	2T	2T
	6-48	Well	"H ₂ O	1.30	-4.60	-4.11	-4.27	-4.05	-5.11	-5.64	-6.37	-6.02	-3.55	-2.63
Lateral		"H ₂ O	-5.18	-5.12	-4.94	-4.69	-3.86	-6.41	-7.98	-6.26	-7.40	-6.98	-10.15	-11.47
CH ₄		%	63.5	58.5	52.9	50.1	48.4	49.4	42.9	36.2	43.8	48.5	49.1	47.5
CO ₂		%	36.5	33.3	27.4	36.7	27.9	24.1	26.7	28.6	30.8	33.2	30.4	32.6
O ₂		%	0.0	1.7	2.4	2.6	3.7	4.1	2.5	1.4	2.1	0.5	1.9	3.0
BAL (N ₂)		%	0.0	6.6	17.3	10.6	19.9	22.4	27.9	33.7	23.3	17.8	18.6	16.9
CO		PPM	4	3	7	10	7	8	10	11	9	5	7	10
H ₂ S		PPM	18	2	4	5	7	7	11	24	11	11	13	11
Vel Max		m/s	0.48	-	-	-	0.00	0.00	0.00	0.56	0.44	0.00	0.00	0.00
Vel Min		m/s	0.77	-	-	-	0.00	0.00	0.98	0.64	0.66	0.00	0.00	0.00
Flow		CFM	5.905898438	-	-	-	0	0	4.630224375	5.6696625	5.197190625	0	0	0
Temp		°C	-7.4	-	-	-	29.3	32.4	21.4	25.4	20.1	10.3	12.4	6.9
Comments			Frozen	2T	2T	2T	2T	2T	1/2T	1/2T	1/2T	1/2T	1/2T	1/2T
6-49		Well	"H ₂ O	-2.40	-2.23	-3.84	-4.31	-1.48	-1.09	-1.30	-1.28	-2.02	-0.21	-4.77
	Lateral	"H ₂ O	-5.34	-5.02	-4.75	-4.62	-3.05	-3.72	-4.69	-5.64	-7.51	-4.78	-7.42	-10.33
	CH ₄	%	54.0	55.4	55.2	54.7	39.7	50.8	47.3	45.8	47.5	57.0	48.7	49.1
	CO ₂	%	38.0	37.3	29.4	31.5	36.1	37.5	36.7	37.0	39.0	40.1	36.2	35.3
	O ₂	%	1.0	1.8	1.0	1.2	1.1	0.3	0.9	0.4	0.8	0.1	1.1	1.2
	BAL (N ₂)	%	7.1	5.5	14.4	12.6	13.1	11.5	15.1	16.9	12.7	2.8	14.0	14.4
	CO	PPM	6	6	6	7	7	14	10	15	12	3	11	10
	H ₂ S	PPM	33	212	202	148	112	313	215	183	164	64	161	157
	Vel Max	m/s	6.56	2.34	-	-	4.59	4.63	2.97	5.59	4.54	5.10	3.34	2.47
	Vel Min	m/s	7.34	2.60	-	-	5.71	5.24	4.10	6.01	4.99	5.67	4.17	2.99
	Flow	CFM	65.67359063	23.34011063	-	-	48.66460313	46.63297406	33.40376156	54.8067375	45.02656969	50.88522094	35.48263781	25.79696438
	Temp	°C	21.7	13.7	-	-	22.6	35.0	24.3	28.3	26.8	19.2	14.6	10.7
	Comments		2T	2T	2T	2T	2->1T	1T	1/2T	1/2T	1/2T	1	1T	1T

Table 2: Wellfield Monitoring Data

Units		13/Jan/20	20/Feb/20	22/Mar/20	25/Apr/20	20/May/20	20/Jun/20	20/Jul/20	24/Aug/20	27/Sep/20	28/Oct/20	28/Nov/20	16/Dec/20	
6-50	Well	"H ₂ O	0.18	FROZEN	FROZEN	0.14	0.22	0.11	0.54	0.10	-0.20	0.14	-1.39	-0.11
	Lateral	"H ₂ O	-6.24	-4.76	-4.66	-4.75	-3.06	-4.69	-6.98	-6.23	-5.99	-4.35	-7.42	-9.63
	CH ₄	%	57.2	19.8	17.6	22.9	60.0	23.0	41.0	59.6	56.1	57.3	14.5	22.5
	CO ₂	%	42.7	16.1	16.2	17.2	40.0	15.7	16.0	39.0	34.0	42.7	12.1	30.6
	O ₂	%	0.1	12.9	13.5	9.0	0.0	8.8	2.6	0.0	3.5	0.0	14.4	5.3
	BAL (N ₂)	%	0.0	51.2	52.7	50.9	0.0	52.5	40.2	1.4	6.4	0.0	59.0	41.6
	CO	PPM	5	6	7	3	5	29	15	11	12	7	5	11
	H ₂ S	PPM	34	20	15	68	120	51	167	346	194	117	22	187
	Vel Max	m/s	-	-	-	-	0.00	0.00	-	0.00	0.00	0.45	-	-
	Vel Min	m/s	-	-	-	-	0.00	0.00	-	0.00	0.00	0.62	-	-
	Flow	CFM	-	-	-	-	0	0	-	0	-	5.055449063	-	-
	Temp	°C	-	-	-	-	-12.8	0.0	-	28.7	24.5	6.2	-	-
	Comments		FROZEN	cracked->closed	closed	closed	closed->cracked	cracked->closed	closed	cracked	cracked	1/2T	closed	closed
	6-51	Well	"H ₂ O	Frozen	-0.15	-1.91	-2.36	-1.09	-0.22	-0.48	-0.72	-2.44	-1.36	-1.11
Lateral		"H ₂ O	-6.19	-4.24	-4.10	-4.85	-3.05	-2.88	-6.94	-5.40	-7.41	-5.68	-10.59	-12.30
CH ₄		%	54.0	54.3	46.2	47.2	38.4	51.0	51.1	51.4	50.4	38.5	40.2	37.6
CO ₂		%	41.1	45.8	27.1	28.7	32.9	42.5	42.7	43.9	39.5	36.6	35.5	38.3
O ₂		%	1.9	0.0	0.0	1.2	3.3	0.2	0.4	0.3	1.5	1.2	1.3	2.0
BAL (N ₂)		%	2.9	0.0	26.7	22.9	25.4	6.3	5.8	4.3	8.6	23.7	23.0	22.1
CO		PPM	6	9	6	5	7	12	10	15	13	10	10	11
H ₂ S		PPM	46	48	46	49	48	124	25	31	40	53	43	41
Vel Max		m/s	0.44	0.00	-	-	2.34	0.55	1.67	2.63	2.15	1.12	-	-
Vel Min		m/s	0.61	0.00	-	-	2.80	0.74	2.47	3.04	2.19	1.27	-	-
Flow		CFM	4.960954688	0	-	-	24.28505438	6.094887188	19.56033563	26.78915531	20.50527938	11.29207781	-	-
Temp		°C	-0.6	9.3	-	-	18.5	32.1	35.1	33.5	29.4	12.9	-	-
Comments			1/2T	1/2T->1T	1T	1T	1->1/2T	1/2T	1T	1T	1T	1/2T	closed	closed
6-52		Well	"H ₂ O	0.06	0.03	-0.11	TOO	Too	-0.01	-0.02	-0.07	-0.05	0.07	-0.04
	Lateral	"H ₂ O	Surging	-3.65	-3.10	TALL	Tall	-4.06	-4.78	-4.19	-7.44	-6.28	-10.47	-10.88
	CH ₄	%	38.3	16.9	18.2	-	-	29.6	16.4	13.9	14.8	56.8	36.4	30.2
	CO ₂	%	37.5	21.0	12.2	-	-	27.6	24.6	23.3	28.9	42.7	29.3	25.1
	O ₂	%	3.8	12.5	13.7	-	-	6.5	5.9	7.1	6.6	0.0	7.1	8.1
	BAL (N ₂)	%	20.4	49.5	55.9	-	-	36.3	53.1	55.6	49.7	0.5	27.2	36.6
	CO	PPM	7	3	10	-	-	7	7	8	6	7	5	8
	H ₂ S	PPM	11	6	2	-	-	12	7	9	10	39	15	12
	Vel Max	m/s	Surging	-	-	-	-	-	-	-	-	-	-	-
	Vel Min	m/s	Surging	-	-	-	-	-	-	-	-	-	-	-
	Flow	CFM	-	-	-	-	-	-	-	-	-	-	-	-
	Temp	°C	Surging	-	-	-	-	-	-	-	-	-	-	-
	Comments		closed	closed	closed	closed	closed	closed	closed	closed	closed	closed	closed	closed
	6-53	Well	"H ₂ O	-0.79	-0.55	-1.32	-3.03	-0.52	-0.78	-2.78	-0.94	0.22	-1.51	-2.16
Lateral		"H ₂ O	-4.91	-3.32	-3.71	-3.62	-2.53	-2.72	-3.69	-4.65	-7.44	-5.21	-9.81	-11.21
CH ₄		%	59.4	55.7	51.2	55.6	59.1	56.0	54.7	53.3	55.7	38.8	46.8	44.9
CO ₂		%	37.4	36.8	26.9	30.8	37.4	36.8	36.1	36.5	33.1	32.1	30.3	29.8
O ₂		%	0.1	0.0	0.2	0.7	0.0	0.0	0.0	0.0	3.5	0.0	3.5	2.9
BAL (N ₂)		%	3.0	7.5	21.7	12.9	3.6	7.2	9.2	10.2	7.7	29.1	19.4	22.4
CO		PPM	7	7	7	10	8	9	7	10	12	7	9	14
H ₂ S		PPM	251	380	371	>>>>	413	>>>>	>>>>	494	>>>>	131	57	>>>>
Vel Max		m/s	8.29	2.10	-	-	4.43	3.82	5.48	7.73	8.44	0.91	0.00	1.52
Vel Min		m/s	8.80	2.30	-	-	5.13	4.79	6.31	8.64	8.64	1.03	0.00	1.36
Flow		CFM	80.74544344	20.7887625	-	-	45.16831125	40.67982844	55.70443406	77.34364594	80.69819625	9.165954375	0	13.60719
Temp		°C	29.9	32.8	-	-	31.9	37.5	35.9	33.8	32.4	26.6	9.3	6.1
Comments			2T	2T	2T	2T	2T	2T	2T	2T	2T	1/2T	1/2T	1/2T
6-54		Well	"H ₂ O	-0.52	-0.27	-0.60	-1.52	-0.94	-1.03	-0.07	-0.11	0.41	-2.10	-0.59
	Lateral	"H ₂ O	Surging	Surging	Surging	Surging	Surging	Surging	Surging	Surging	Surging	-5.78	-10.68	-10.27
	CH ₄	%	55.9	59.5	54.5	52.6	46.1	45.3	55.3	57.8	55.1	35.5	45.9	43.1
	CO ₂	%	37.1	39.2	31.4	30.9	32.1	31.3	31.5	39.2	36.4	25.3	39.4	33.6
	O ₂	%	1.5	0.7	0.8	1.4	4.5	3.1	1.3	0.0	1.4	6.2	1.8	2.4
	BAL (N ₂)	%	5.4	0.5	13.3	15.1	17.3	20.3	11.9	2.9	7.1	33.0	12.9	20.9
	CO	PPM	4	5	4	9	5	8	11	12	10	6	11	9
	H ₂ S	PPM	12	22	16	24	46	85	100	119	101	19	120	115
	Vel Max	m/s	Surging	Surging	-	Surging	Surging	2.01	Surging	Surging	0.00	0.00	0.00	0.00
	Vel Min	m/s	Surging	Surging	-	Surging	Surging	2.09	Surging	Surging	0.00	0.00	0.00	0.00
	Flow	CFM	-	-	-	-	-	19.37134688	-	-	0	0	0	0
	Temp	°C	Surging	Surging	-	Surging	Surging	36.2	Surging	Surging	21.5	12.9	8.2	5.4
	Comments		2T	2T	2T	2T	2T	2->1T	2T	2T	2T	1/2T	1/2T	1/2T

Table 2: Wellfield Monitoring Data

	Units	13/Jan/20	20/Feb/20	22/Mar/20	25/Apr/20	20/May/20	20/Jun/20	20/Jul/20	24/Aug/20	27/Sep/20	28/Oct/20	28/Nov/20	16/Dec/20	
7-60	Well	"H ₂ O	-4.90	-5.26	0.02	0.10	5.02	-3.85	-0.27	-0.64	-1.12	-1.91	-7.48	-7.99
	Lateral	"H ₂ O	-5.44	-5.30	-5.02	-4.26	-3.41	-4.44	-6.93	-7.14	-7.95	-1.47	-8.57	-10.22
	CH ₄	%	47.3	0.5	1.4	36.8	60.5	57.4	45.1	46.7	40.6	64.7	58.3	56.3
	CO ₂	%	24.2	0.3	12.6	10.1	31.8	29.5	31.6	32.4	30.5	32.9	31.3	32.4
	O ₂	%	4.8	17.1	18.4	18.6	0.7	1.8	1.1	1.5	2.3	1.0	1.8	1.2
	BAL (N ₂)	%	23.7	82.1	67.6	34.5	6.9	11.3	22.2	18.5	26.6	1.4	8.6	10.1
	CO	PPM	4	2	10	11	9	10	12	14	15	7	7	9
	H ₂ S	PPM	43	0	2	12	29	46	39	25	30	22	55	32
	Vel Max	m/s	0.50	-	-	-	0.00	0.00	0.58	1.10	1.60	0.00	5.14	4.25
	Vel Min	m/s	0.66	-	-	-	0.44	0.00	0.96	1.73	1.65	0.00	6.32	4.96
	Flow	CFM	5.48067375	-	-	-	2.07887625	0	7.276066875	13.37095406	15.35533594	0	54.14527688	43.51465969
	Temp	°C	-5.8	-	-	-	30.9	38.0	29.1	28.4	25.9	19.4	15.1	8.4
	Comments		Frozen	2T->closed	closed	closed	closed->cracked	cracked->1/2T	1/2T	1/2T	1/2T	2	2	2
	7-61	Well	"H ₂ O	Frozen	0.24	-1.11	Too	Too	Too	-3.41	-4.11	34.00	-3.55	-3.52
Lateral		"H ₂ O	-5.87	-4.66	-4.74	Tall	Tall	Tall	-6.44	-7.54	NLV	-9.31	-12.50	
CH ₄		%	57.3	51.7	48.6	-	-	-	48.1	47.9	55.8	54.5	46.1	
CO ₂		%	42.4	48.6	27.5	-	-	-	33.2	35.1	44.2	40.9	32.1	
O ₂		%	0.3	0.0	0.0	-	-	-	2.3	3.1	0.0	3.6	4.5	
BAL (N ₂)		%	0.0	0.0	23.9	-	-	-	16.4	14.2	14.2	1.0	17.3	
CO		PPM	7	34	35	-	-	-	8	19	21	24	15	
H ₂ S		PPM	262	>>>>	>>>>	-	-	-	14	18	>>>>	229	230	
Vel Max		m/s	2.03	0.00	-	-	-	-	2.33	3.51	0.00	1.33	1.87	
Vel Min		m/s	2.85	0.00	-	-	-	-	3.18	3.62	0.00	1.70	1.55	
Flow		CFM	23.0566275	0	-	-	-	-	26.03320031	33.68724469	0	14.31589781	16.15853813	
Temp		°C	-1.6	5.4	-	-	-	-	26.2	25.4	0.0	10.2	10.2	
Comments			2->1T	1T	1T	1T	1T	1T	1T	1T	1T	1T	1T	
7-62		Well	"H ₂ O	-0.01	0.79	0.44	0.15	0.17	ACTIVE	-2.98	-3.65	-2.84	0.11	-4.91
	Lateral	"H ₂ O	BURIED	BURIED	BURIED	-1.45	-2.75	WORK	-5.36	-6.93	-7.95	-3.78	-8.93	-10.51
	CH ₄	%	60.0	59.2	47.4	62.4	57.7	AREA	48.2	49.5	46.8	60.5	48.4	45.2
	CO ₂	%	40.0	40.8	24.1	37.3	41.4	35.4	37.4	36.5	39.2	35.4	32.1	
	O ₂	%	0.0	0.0	0.0	0.0	0.0	2.9	3.6	2.5	0.0	3.2	3.6	
	BAL (N ₂)	%	0.0	0.0	28.5	0.3	0.9	13.5	9.5	14.2	0.3	13.0	19.1	
	CO	PPM	5	0	7	5	9	25	31	28	9	10	18	
	H ₂ S	PPM	220	320	351	>>>>	>>>>	80	71	80	>>>>	134	155	
	Vel Max	m/s	BURIED	BURIED	BURIED	BURIED	-	0.69	1.67	1.22	3.98	1.17	1.62	
	Vel Min	m/s	BURIED	BURIED	BURIED	BURIED	-	1.47	2.01	1.36	4.11	1.02	1.32	
	Flow	CFM	-	-	-	-	-	0	10.2053925	17.386965	12.18977438	38.22297469	10.34713406	13.89067313
	Temp	°C	BURIED	BURIED	BURIED	BURIED	-	-	22.3	22.3	28.4	28.4	9.8	2.7
	Comments		3T->1T	1T	1T	1T	1T	1T	1T	1T	1T	2	1T	1T
	7-64	Well	"H ₂ O	-0.17	0.05	-1.38	-0.61	0.07	-0.04	-0.04	-0.01	-1.22	0.10	-9.48
Lateral		"H ₂ O	-7.12	-4.71	-4.39	-4.11	-3.41	-3.04	-2.63	-1.89	-6.58	-5.23	-14.00	-12.10
CH ₄		%	37.9	46.9	49.2	50.0	44.1	52.3	52.6	53.7	50.3	50.8	26.4	43.6
CO ₂		%	30.7	34.0	26.8	28.1	33.0	38.7	38.5	40.0	39.5	41.2	30.7	31.2
O ₂		%	0.4	0.0	0.2	0.3	0.0	0.0	0.4	1.0	2.5	2.5	0.4	3.6
BAL (N ₂)		%	31.0	19.0	23.8	21.6	22.9	8.9	8.5	5.4	7.7	0.0	42.5	21.6
CO		PPM	7	6	6	2	6	9	8	10	7	10	10	8
H ₂ S		PPM	57	118	108	136	104	14	95	113	105	142	24	137
Vel Max		m/s	1.89	1.21	-	-	4.90	1.59	1.24	0.83	0.88	1.63	7.84	1.88
Vel Min		m/s	2.55	1.10	-	-	7.72	1.82	1.57	1.82	0.95	5.35	9.11	1.59
Flow		CFM	20.97775125	10.91410031	-	-	59.62595063	16.11129094	13.27645969	12.52050469	8.646235313	32.97853688	80.08398281	16.39477406
Temp		°C	13.3	18.4	-	-	29.4	32.7	30.4	30.4	28.1	19.7	8.3	4.9
Comments			2->1T	1T	1T	1T	1T	1T	1T	1T	1T	2	1T	1T
7-65		Well	"H ₂ O	0.04	0.02	0.03	0.09	0.10	0.04	0.00	0.13	-0.01	-0.07	-3.15
	Lateral	"H ₂ O	-7.71	SURGING	SURGING	SURGING	SURGING	NLV	NLV	-0.69	-5.99	-6.17	-14.04	-10.11
	CH ₄	%	38.8	56.1	50.3	48.2	43.4	55.1	54.9	50.1	46.8	34.4	22.1	35.4
	CO ₂	%	31.5	36.4	28.9	33.5	33.5	36.5	35.2	36.6	37.5	31.1	24.2	29.8
	O ₂	%	1.1	0.0	0.2	0.0	0.0	0.0	0.0	2.4	3.3	0.4	2.9	6.9
	BAL (N ₂)	%	28.6	7.5	20.6	18.3	23.0	8.4	9.9	11.0	12.4	34.1	50.8	27.9
	CO	PPM	9	7	5	3	7	9	15	12	10	12	8	8
	H ₂ S	PPM	42	249	220	196	137	250	214	207	209	163	18	189
	Vel Max	m/s	SURGING	SURGING	-	SURGING	SURGING	-	-	7.89	8.88	Surging	-	-
	Vel Min	m/s	SURGING	SURGING	-	SURGING	SURGING	-	-	11.14	8.89	-	-	-
	Flow	CFM	-	-	-	-	-	-	-	89.91139781	83.95825219	-	-	-
	Temp	°C	SURGING	SURGING	-	SURGING	SURGING	-	-	40.1	36.5	-	-	-
	Comments		1->Closed	closed->1T	1T	1T	1->1/2T	NLV	NLV	1/2T	1/2T	1/2T	closed	closed

Table 4: Water Levels

Units	Mar 25/26,2020						July 22/23,2020				Oct 26/27,2020			
	meters	meters	meters	meters	°C	%	meters	meters	°C	%	meters	meters	°C	%
Locations	Screen Length	Installed Well Depth	Depth to Water	Depth to Bottom	Temperature	Open Screen	Depth to Water	Depth to Bottom	Temperature	Open Screen	Depth to Water	Depth to Bottom	Temperature	Open Screen
H-1	12	14.63	7.70	14.30	26.0	43.14	7.80	14.80	25.3	43.96	8.00	14.70	23.8	45.60
H-2	14	16.77	8.90	18.20	28.1	42.65	8.70	18.60	27.4	41.19	8.90	18.60	26.1	42.65
H-3	12	15.24	7.10	16.20	11.3	33.22	7.00	16.40	13.4	32.40	7.20	16.30	10.5	34.04
H-4	11	14.02	8.00	9.80	15.1	45.11	8.50	10.00	16.0	49.67	8.80	9.90	15.9	52.40
1-5	11	13.72	8.00	15.00	20.2	46.40	8.10	14.90	21.8	47.34	8.10	14.80	20.7	47.34
1-6	12	15.55	10.80	16.70	22.8	61.06	10.70	16.60	24.0	60.24	10.90	16.50	22.9	61.88
1-7	18	21.34	14.50	19.70	28.4	62.60	14.60	19.80	32.9	63.15	14.90	19.50	31.0	64.79
1-8	21	24.39	15.10	23.10	33.1	56.47	18.00	23.80	32.3	70.06	16.40	24.00	31.9	62.56
1-9	12	14.63	10.50	14.70	32.5	66.10	12.40	14.80	33.1	81.68	13.50	14.90	32.2	90.70
1-10	9	12.20	10.20	12.00	24.8	78.19	10.00	12.10	27.0	76.00	10.20	12.30	27.2	78.19
H-11	9	12.80	FOAM	12.00	21.5	-	FOAM	8.50	21.6	-	FOAM	9.80	20.7	-
H-12	13	16.16	no port			-	no port			-	no port			-
2-13	21	25.00	7.70	9.40	40.4	18.94	8.30	18.60	41.3	21.75	8.40	18.50	36.8	22.22
2-14	20	22.56	7.00	22.30	30.4	21.48	7.80	22.60	32.3	25.51	7.10	21.80	31.5	21.98
2-15	18	21.65	12.00	22.10	17.7	48.91	12.30	22.10	20.3	48.91	12.50	22.20	21.0	50.00
2-16	26	28.35	22.10	29.00	16.1	75.87	21.60	29.40	30.5	73.94	21.40	29.50	28.5	73.17
2-17	15	18.29	12.80	17.50	22.3	63.97	13.30	18.40	21.9	67.25	13.30	18.20	21.6	67.25
2-18	15	18.29	14.40	18.60	28.7	74.46	14.20	16.00	34.3	73.15	14.10	16.80	33.9	72.50
3-19	12	14.94	9.00	14.30	15.8	51.30	7.80	14.40	18.4	41.46	8.20	14.50	15.7	44.74
3-20	11	13.26	8.50	14.70	14.3	55.37	8.60	14.50	15.9	56.31	8.90	14.80	16.0	59.12
3-21	5	7.62	4.40	8.00	9.8	29.55	4.50	7.90	19.1	31.73	4.20	8.10	18.9	25.17
3-22	24	26.68	13.00	18.40	34.3	43.22	6.80	18.00	35.0	17.47	9.60	17.80	33.8	29.10
3-23	23	25.91	10.00	16.20	30.3	30.40	TOO TALL			-	TOO TALL			-
3-24	21	23.48	6.50	18.30	34.3	20.46	7.40	19.50	36.0	24.67	8.30	19.70	36.1	28.89
3-25	18	21.34	8.80	25.30	34.3	31.44	5.60	18.40	35.5	13.95	6.90	18.10	33.8	21.05
3-26	9	12.20	4.30	13.90	20.5	13.68	4.50	14.20	28.6	15.87	5.30	14.50	36.5	24.61
3-27	21	24.09	6.80	18.40	39.3	19.01	7.40	19.50	40.7	21.82	7.50	19.90	39.1	22.29
3-28	12	15.24	3.00	15.90	14.4	0.00	3.60	15.80	18.5	4.52	3.30	15.50	15.0	2.06
3-29	12	14.63	7.70	15.00	33.3	43.14	8.50	14.90	36.2	49.70	9.00	14.40	37.0	53.80
3-30	7	9.76	5.00	8.70	39.7	35.00	5.80	8.80	40.3	45.93	5.60	9.00	38.9	43.20
4-31	16	18.75	8.30	18.20	24.1	35.33	8.60	18.30	24.8	37.18	8.80	18.10	22.5	38.42
4-32	10	12.50	5.00	11.00	30.5	23.13	6.30	11.40	31.9	36.45	6.90	11.40	30.9	42.60
4-33	24	26.68	7.30	22.30	23.3	20.56	5.80	20.70	32.3	14.41	6.30	21.60	29.1	16.46
4-34	20	22.56	4.50	20.90	33.7	8.86	5.90	20.40	34.9	15.93	6.20	20.10	33.6	17.44
4-35	15	17.38	7.60	18.80	24.1	35.86	7.40	18.50	22.5	34.54	7.90	17.40	21.8	37.82
4-36	15	18.29	too tall			-	3.60	18.70	38.60	3.62	3.70	18.20	36.20	4.27
4-37	12	14.94	9.50	14.90	36.1	55.40	9.50	14.80	37.6	55.40	9.30	15.70	35.6	53.76
5-38	8	10.67	4.20	12.00	11.8	15.10	4.40	12.00	14.8	17.73	4.50	12.50	12.1	19.04
5-39	8	10.67	4.50	12.40	14.2	19.04	4.50	12.40	16.7	19.04	4.30	12.60	15.6	16.42
5-40	18	21.95	5.20	12.40	34.7	8.43	5.70	14.70	35.7	11.16	6.10	15.40	33.6	13.35
5-41	17	18.90	9.00	15.70	30.8	40.95	10.50	15.80	31.0	49.89	10.80	16.10	30.4	51.68
5-42	12	16.16	9.80	13.60	31.4	47.86	10.30	14.60	39.7	51.96	9.80	15.30	40.2	47.86
5-43	14	16.16	5.5	12.4	19.3	22.31	5.6	12.2	22.2	23.04	5.8	12.3	21.9	24.50
5-44	19	21.95	11.7	16.2	34.1	45.77	12	12.4	34.8	47.35	13.2	14.9	33.2	53.70
5-45	15	16.77	5.3	15.5	30.1	24.77	6.6	16.6	35.6	33.30	7.2	15.7	34	37.23
5-46	16	18.90	7.9	17.2	-	30.60	8.1	17.1	22.4	31.86	7.6	16.3	31.1	28.71
6-47	14	15.85	5	13.9	24.2	20.89	5.4	13.9	22.3	23.80	5.3	13.9	21.4	23.08
6-48	15	17.68	4.7	15.6	21.9	11.28	5	15.5	29.3	13.33	5.1	15.3	28.5	14.02
6-49	20	23.48	14	23.5	37.8	53.61	15.6	23.2	32.8	61.44	14.4	23.8	31.7	55.57
6-50	14	17.38	13.6	17	34.2	73.63	13.1	16.6	39.2	70.14	13.5	16.5	39	72.94
6-51	12	14.94	5	6.4	23.7	18.50	5.2	5.5	27.4	20.14	5.7	5.4	26.9	24.24
6-52	6	9.15	too tall			-	5.2	7.5	26.5	35.28	4.7	7.7	25.1	27.08
6-53	22	23.63	14.2	21.9	35.3	57.35	13.5	22	36.9	54.18	14.3	22.1	35.8	57.80
6-54	13	15.85	6.8	15.3	27.8	30.94	7	15.2	27.6	32.47	7.1	15.5	26.2	33.23
6-55	18	21.34	16	21	38.7	70.80	15.8	22	33.4	69.71	14.8	21.4	31.7	64.24
6-56	10	12.80	5	13.4	35.6	22.42	4.2	13.2	37.9	14.47	4.9	12.9	36.4	21.43
6-57	0	0.00	10.7	14.7	36	-	11.5	14.3	36.8	-	11.6	14.5	35.6	-
6-58	0	0.00	10	21.7	26.9	-	9.7	21.2	28.1	-	8.9	21.6	29.5	-
6-59	17	20.12	16.4	21.3	22.5	78.20	16.2	21.3	38.4	77.03	16.3	21	37.5	77.61
7-60	13	15.55	5.2	14	25.5	17.21	5.6	14.1	27.4	20.41	5.5	14.5	27.3	19.61
7-61	13	15.24	too tall			-	too tall			-	too tall			-
7-62	17	18.29	16.6	17.6	23.9	89.91	16.9	17.4	26.1	91.69	16.8	16.9	24.6	91.10
7-64	22	24.09	17.1	26.7	32.1	68.18	17	26.2	35.4	67.72	17.5	26.3	33.9	70.00
7-65	24	26.22	17	27.6	34.5	61.23	17	28.2	35.6	61.23	17.6	28.1	34.2	63.75
7-66	19	21.95	16	24.3	30.7	-	16	23	30.1	-	16.2	22.8	29.6	-

2.3 Surface Emission Monitoring

As required by the City, surface emission monitoring is requested to be carried out semi-annually, weather conditions permitting, by Comcor. This monitoring is performed using a portable flame ionization detector (FID) and a GPS, marking locations where concentrations of hydrocarbons were greater than 500 ppm. The surface emission monitoring was completed in May and October for the 2020 reporting year. Several areas were noted where there were significant volumes of gas detected, including areas where cap was weak, pipe emanated from the landfill surface, uncovered manholes and/or manholes lacking proper sealing.

2.4 Mechanical System Monitoring

The main operational control of the mechanical system is carried out by the Programmable Logic Controller (PLC). The PLC also provides information on the operating status of the system, and records all data electronically which can be downloaded when required. Specific details on these items are included in the Flare Operation and Maintenance Manual. At a minimum the PLC records:

- Landfill gas composition and temperature
- Flare operating times
- Blower operating times
- Landfill gas flow rate
- Volume of landfill gas collected and flared
- Greenhouse Gas Emission Reduction in CO₂ equivalents.

These items were also monitored remotely and were reviewed at minimum on a weekly basis to ensure that all parameters outlined above are being recorded and that all system data indicates that the overall system is operating properly. The system review was carried out by a technician experienced in the operation of such systems. Notably, the internet at the Site was upgraded in November which prevented the system from recording of the aforementioned parameters until access was provided by the City. Upon providing the required information, the ability to communicate with the flare was restored and the previously unrecorded data was recovered.

Comcor staff also carried out the maintenance of the system as outlined by the Operations and Maintenance Manual. No other major repairs had to be made to the mechanical system during 2020.

Data for 2020 has been compiled, and is found in Appendix A.

2.4.1 System Pressure Measurements

Monitoring ports at the inlet and outlet to the blower were measured and recorded on a monthly frequency, using a suitably scaled pressure gauge. Gauge fluctuations were noted, as it can be an indication of water within the system.

Data for 2020 has been compiled, and is found in Table 2.

2.4.2 System Gas Measurements

The purpose of the main blower skid gas analyzer system is to monitor the oxygen and methane concentrations of the landfill gas being transferred by the LGFCS to the flare. As a safety precaution, if either the oxygen concentration gets too high, or the methane concentration gets too low, an alarm is sent to the main computer control panel PLC to shut the system down. Having records of the gas concentrations also allows for better analysis of the system and aids in troubleshooting when problems arise.

A pump, located within the gas analyzer system cabinet in the control room, is used to draw a continuous sample of process gas from the header pipe on the blower discharge side. After entering the analyzer, the sample is drawn through a de-mister and a series of filters to remove any particulate or moisture that may affect the monitoring equipment. The methane and oxygen concentrations of the sample are then measured by an infra-red methane analyzer and oxygen analyzer. The methane and oxygen concentrations are displayed on separate LED display screens mounted on the front face of the gas analyzer panel. The gas analyzer system will send signals to the PLC that will trigger a number of system alarms/warnings including low methane and high oxygen.

All system failures and/or alarms are displayed on the main control circuit panel. Any alarms that shut down the system are relayed by the auto messaging to the system operator.

During 2020, the system operated as intended with the analyzer data recorded at an interval of five minutes or better and any system alarms were sent to the operator. This data was recorded and summarized into a daily value and can be found in Appendix A.

In addition to the main system analyser, concentrations of methane (CH₄), carbon dioxide (CO₂) and oxygen (O₂) were measured manually, recorded monthly at the blower inlet and blower outlet, and compared to the insitu monitoring devices to ensure accuracy. These measurements were taken using a proper gas meter/analyzer such as a Landtec GEM-5000+, or equivalent.

2.4.3 System Flow Rate Measurements

Landfill gas velocities and temperatures at each landfill gas extraction well in the wellfield were measured and recorded on a monthly basis using an anemometer, if possible. These velocities were used to calculate landfill gas flow rates by multiplying by the pipe's cross sectional area.

A thermal mass flow meter continuously calculates flows to the flare and this data was recorded on an interval of 5 minutes or less.

The monitoring completed in 2020 is found in Table 2 and a summary of daily plant data can be found in Appendix A.

3.0 FLARE AND GREENHOUSE GAS EMISSIONS

3.1 Flare Emissions

The flare stack is equipped with four thermocouples that measure the temperature in the flare stack. These thermocouples are monitored by the system control panel PLC at intervals of 5 minutes or better. The control system is continuously monitoring the flame conditions and will shut down the LGCFS system immediately if flame is lost.

If the system shuts down for any reason, the fail safe valve will close and prevent any non-combusted landfill gas from being released to the atmosphere, thereby controlling the emissions from the flare.

3.2 Greenhouse Gas Emissions

The landfill gas is comprised of primarily methane and carbon dioxide in approximately equal amounts. In addition there are other trace amounts of a large number of compounds. Methane and carbon dioxide are greenhouse gases but methane has a global warming potential 25 times that of carbon dioxide. By combusting the methane in the flare the resultant products are carbon dioxide and water vapour which reduces its global warming potential by approximately 95 percent.

The control panel records both flow and methane gas concentration being collected from the system and sent to be combusted in the flare. These quantities are measured and recorded at intervals of 5 minutes or less. The data collected can be readily processed to calculate the greenhouse gas emission reduction expressed as carbon dioxide equivalents.

For the Brady Road Landfill, greenhouse gas emissions have been calculated based on operational data and can be found in Appendix A.

4.0 CONDENSATE COLLECTION SYSTEM

The purpose of the Condensate Collection System component of the LGCFS is to remove moisture from the landfill gas and to collect condensate from the collection laterals/header pipes. Collection and removal of the condensate increases the efficiency of the landfill gas collection in the wellfield and minimizes the moisture being passed through the mechanical system.

Condensate and moisture are removed from the system at three main locations. First, relative low points have been provided in the gas collection header to allow any free moisture to drain by gravity out of the underground gas collection system. In the wellfield, this moisture drains into condensate gravity style and pump style drain traps which have pneumatic pumps installed inside the sump. Next, prior to the gas entering the blowers, a condensate moisture separator removes most of the residual water droplets remaining in the gas. At this stage the residual water drains by gravity into the condensate chamber.

The condensate chamber stores the water until the pump at the bottom of the chamber is activated either manually or automatically through a series of floats. The water is then pumped through a 75 mm diameter HDPE forcemain and is discharged into the leachate collection system.

After completion of the landfill gas collection system 2019 southern header expansion, Viridian VP4 pneumatic pumps were installed in nine manholes (MH3, MH4, MH5, MH8, MH31, MH32, MH33, MH42 and MH43) to send leachate directly to the storage tank located in the southwest corner of the Site. Prior to the 2020 expansion, condensate/leachate from the existing dual purpose wells, pump drain traps, and the condensate chamber was discharged to manhole MH32, where a vacuum tanker would periodically pump down the manhole. With the installation of a pneumatic pump in manhole MH32, condensate/leachate from the landfill gas collection system is now pumped directly to the storage tank.

5.0 CONCLUSIONS AND RECOMMENDATIONS

1. During operation in 2020, the Brady Road Resource Management Facility Gas Collection and Flaring System operated as was intended.
2. During surface emission monitoring, some areas were noted where gas was escaping. These areas included open manholes and areas of weak surface cap. In order to get maximum efficiency from the LGCFS, these issues should be looked at in the future.
3. The system should continue to operate on a full-time basis and be monitored according to the Operation and Maintenance Manual for the site.

All of which is Respectfully Submitted,

INTEGRATED GAS RECOVERY SERVICES



Christine Grant, EIT
Engineering Project Coordination



Shannan McGarr, B.Sc.
Wellfield Operations Manager

APPENDIX A
PLANT AND FLARE DATA

Date	CO2 Equivalents			Landfill Gas Flow						Methane	Oxygen	Flare	Flare	Temperature			Blower 1		Blower 2	
	Yearly	Monthly	Daily	Yearly	Monthly	Daily	Daily	Avg	Total	Avg	Avg	Run Hours	Starts	Min.	Avg.	Max.	Daily	Cumu.	Daily	Cumu.
	Tonnes CO2	Tonnes CO2	Tonnes CO2	scf	scf	scf	meter3	scfm	MMBTU	(%)	(%)			°C	°C	°C	Hours	Hours	Hours	Hours
Jan 1 2020	285	285	285	1296173	1296173	1296173	36718	900	627	47.8	2.3	24	0	866	900	932	0	25753.6	24.2	26326
Jan 2 2020	550	550	265	2592391	2592391	1296218	36719	900	584	44.5	3.5	24	0	859	900	937	0	25753.6	24.2	26350.2
Jan 3 2020	808	808	258	3888719	3888719	1296328	36722	900	567	43.2	3.9	24	0	866	900	931	0	25753.6	23.1	26373.3
Jan 4 2020	1076	1076	268	5184998	5184998	1296279	36721	900	588	44.9	3.4	24	0	872	900	928	0	25753.6	24.2	26397.6
Jan 5 2020	1336	1336	260	6482020	6482020	1297022	36742	901	571	43.5	3.9	24	0	869	900	935	0	25753.6	24.2	26421.8
Jan 6 2020	1600	1600	264	7777776	7777776	1295756	36706	900	580	44.2	3.7	24	0	864	900	939	0	25753.6	24.1	26445.9
Jan 7 2020	1826	1826	226	8968409	8968409	1190633	33728	900	496	41.2	4.7	20.1	1	870	900	922	0	25753.6	23.5	26469.4
Jan 8 2020	2087	2087	261	10264442	10264442	1296033	36714	900	573	43.7	3.8	24	0	859	900	925	0	25753.6	24.1	26493.5
Jan 9 2020	2348	2348	261	11559730	11559730	1295288	36693	900	573	43.7	4	24	0	872	900	934	0	25753.6	24.1	26517.6
Jan 10 2020	2592	2592	244	12855494	12855494	1295764	36706	900	537	41	4.7	24	0	858	900	932	0	25753.6	23.1	26540.7
Jan 11 2020	2840	2840	248	14151886	14151886	1296392	36724	900	546	41.6	4.5	24	0	860	900	927	0	25753.6	24.1	26564.8
Jan 12 2020	3086	3086	246	15447216	15447216	1295330	36694	900	542	41.3	4.7	24	0	890	900	912	0	25753.6	24.2	26589
Jan 13 2020	3332	3332	246	16742639	16742639	1295423	36697	900	540	41.2	4.8	24	0	865	900	931	0	25753.6	24.1	26613.1
Jan 14 2020	3570	3570	238	18037845	18037845	1295206	36691	899	523	39.9	5.1	24	0	853	900	932	0	25753.6	24.1	26637.2
Jan 15 2020	3800	3800	230	19333627	19333627	1295782	36707	900	507	38.6	5.5	24	0	851	900	924	0	25753.6	23.1	26660.3
Jan 16 2020	4027	4027	227	20629556	20629556	1295929	36711	900	500	38.1	5.5	24	0	865	900	917	0	25753.6	24.1	26684.4
Jan 17 2020	4271	4271	244	21924428	21924428	1294872	36681	899	537	41	4.7	24	0	890	900	912	0	25753.6	24.2	26708.6
Jan 18 2020	4499	4499	228	23219377	23219377	1294949	36683	899	502	38.3	5.6	24	0	887	900	914	0	25753.6	24.1	26732.7
Jan 19 2020	4715	4715	216	24514824	24514824	1295447	36697	900	475	36.3	6.3	24	0	875	900	916	0	25753.6	24.1	26756.8
Jan 20 2020	4944	4944	229	25808911	25808911	1294087	36659	900	503	38.4	5.4	23.9	1	870	900	922	0	25753.6	23.9	26780.7
Jan 21 2020	5184	5184	240	27104216	27104216	1295305	36693	899	527	40.2	5.1	24	0	886	900	918	0	25753.6	23.1	26803.9
Jan 22 2020	5408	5408	224	28399831	28399831	1295615	36702	900	492	37.5	6	24	0	870	900	928	0	25753.6	24.1	26828
Jan 23 2020	5632	5632	224	29695952	29695952	1296121	36717	900	494	37.6	6	24	0	871	900	937	0	25753.6	24.1	26852.1
Jan 24 2020	5872	5872	240	30993229	30993229	1297277	36749	901	528	40.2	5.2	24	0	866	900	927	0	25753.6	24.1	26876.2
Jan 25 2020	6114	6114	242	32288810	32288810	1295581	36701	900	532	40.6	5.1	24	0	875	900	926	0	25753.6	23.1	26899.3
Jan 26 2020	6352	6352	238	33583782	33583782	1294972	36684	899	523	39.9	5.3	24	0	866	900	927	0	25753.6	24.2	26923.5
Jan 27 2020	6589	6589	237	34878406	34878406	1294624	36674	899	521	39.8	5.3	24	0	858	900	936	0	25753.6	24.1	26947.6
Jan 28 2020	6654	6654	65	35230943	35230943	352537	9987	900	143	40.1	5.2	6.5	0	872	900	916	0	25753.6	6	26953.6
Jan 29 2020	6654	6654	0	35230943	35230943	0	0	0	0	0	0	0.0	0	0	0	0	0	0	0	0
Jan 30 2020	6790	6790	136	35844959	35844959	614016	17394	899	298	48	2.5	11.4	1	-1	890	959	0	25753.6	50.2	27003.8
Jan 31 2020	7067	7067	277	37141863	37141863	1296904	36739	901	608	46.4	2.7	24	0	880	900	918	0	25753.6	24.2	27028
Feb 1 2020	7335	268	268	38437271	1295408	1295408	36696	900	589	45	3.4	24	0	853	900	924	0	25753.6	23.1	27051.1
Feb 2 2020	7580	513	245	39734072	2592209	1296801	36736	901	539	41.1	5	24	0	872	900	938	0	25753.6	24.2	27075.3
Feb 3 2020	7829	762	249	41029365	3887502	1295293	36693	899	548	41.8	4.5	23.5	0	868	900	924	0	25753.6	23.1	27098.4
Feb 4 2020	7961	894	132	41698667	4556804	669302	18960	900	290	42.8	4.8	0	0	858	900	930	0	25753.6	13.1	27111.5
Feb 5 2020	7961	894	0	41698667	4556804	0	0	0	0	0	0	0.0	0	0	0	0	0	0	0	0
Feb 6 2020	8084	1017	123	42316044	5174181	617377	17489	899	271	43.4	4.1	11	1	225	899	934	0	25753.6	59.5	27170.9
Feb 7 2020	8344	1277	260	43611574	6469711	1295530	36700	900	572	43.6	4	24	0	868	900	927	0	25753.6	24.1	27195
Feb 8 2020	8604	1537	260	44906800	7764937	1295226	36691	899	572	43.7	4.2	24	0	871	900	926	0	25753.6	23.1	27218.1
Feb 9 2020	8866	1799	262	46201526	9059663	1294726	36677	899	576	44	4	24	0	869	900	925	0	25753.6	24.2	27242.3
Feb 10 2020	9126	2059	260	47497785	10355922	1296259	36720	900	572	43.6	4.2	24	0	869	900	925	0	25753.6	24.2	27266.5
Feb 11 2020	9394	2327	268	48794144	11652281	1296359	36723	900	590	45	3.8	24	0	859	900	931	0	25753.6	24.1	27290.6
Feb 12 2020	9661	2594	267	50009033	12948170	1295889	36710	900	588	44.8	5.3	24	0	856	900	941	0	25753.6	23.2	27313.9
Feb 13 2020	9919	2852	258	51386185	14244322	1296152	36717	900	568	43.3	4.1	24	0	864	900	936	0	25753.6	24.2	27338.1
Feb 14 2020	10192	3125	273	52683010	15541147	1296825	36736	901	600	45.7	3.5	24	0	871	900	928	0	25753.6	24.1	27362.2
Feb 15 2020	10453	3386	261	53981580	16839717	1298570	36786	902	574	43.7	4	24	0	860	900	930	0	25753.6	24.2	27386.4
Feb 16 2020	10715	3648	262	55274647	18132784	1293067	36630	898	577	44.1	3.8	24	0	853	900	940	0	25753.6	23.1	27409.5
Feb 17 2020	10972	3905	257	56556903	19415040	1282256	36324	890	566	43.6	4	24	0	854	900	939	0	25753.6	24.2	27433.7
Feb 18 2020	11224	4157	252	57857138	20715275	1300235	36833	903	554	42.1	4.4	24	0	860	900	936	0	25753.6	24.2	27457.9
Feb 19 2020	11477	4410	253	59148514	22006651	1291376	36582	897	555	42.5	4.2	24	0	861	900	940	0	25753.6	24.1	27482
Feb 20 2020	11743	4676	266	60444938	23303075	1296424	36725	900	585	44.6	3.6	24	0	873	900	930	0	25753.6	23.2	27505.2
Feb 21 2020	12013	4946	270	61744238	24602375	1299300	36807	902	593	45.1	3.6	24	0	867	900	931	0	25753.6	24.1	27529.3
Feb 22 2020	12287	5220	274	63042540	25900677	1298302	36778	902	602	45.8	3.4	24	0	865	900	925	0	25753.6	24.1	27553.4
Feb 23 2020	12558	5491	271	64339207	27197344	1296667	36732	900	595	45.3	3.5	24	0	871	900	941	0	25753.6	24.2	27577.6
Feb 24 2020	12606	5539	48	64573286	27431423	234079	6631	901	106	44.8	3.6	4.3	0	868	899	939	0	25753.6	4.5	27582.1
Feb 25 2020	12606	5539	0	64573286	27431423	0	0	0	0	0	0	0.0	0	0	0	0	0	0	0	0
Feb 26 2020	12607	5540	1	64578480	27436617	5194	147	858	2	46.3	20.1	1	1	-14	170	482	0	25753.6	0.1	27582.2
Feb 27 2020	12607	5540	0	64578480	27436617	0	0	0	0	0	0	0.0	0	0	0	0	0	0	0	0
Feb 28 2020	12772	5705	165	65307624	28165761	129144	20655	899	362	49.1	2.7	13.5	1	-12	894	960	0	25753.6	13.1	27595.3
Feb 29 2020	12870	5803	98	65741528	28599665	433904	12292	900	216	49.1	2.5	8.0	0	887	900	913	0	25753.6	8.4	27603.6
Mar 1 2020	13017	147	147	66396931																

Date	CO2 Equivalents			Landfill Gas Flow						Methane	Oxygen	Flare	Flare	Temperature			Blower 1		Blower 2	
	Yearly	Monthly	Daily	Yearly	Monthly	Daily	Daily	Avg	Total	Avg	Avg	Run Hours	Starts	Min.	Avg.	Max.	Daily	Cumu.	Daily	Cumu.
	Tonnes CO2	Tonnes CO2	Tonnes CO2	scf	scf	scf	meter3	scfm	MMBTU	(%)	(%)			°C	°C	°C	Hours	Hours	Hours	Hours
Mar 8 2020	14174	1304	0	71499640	5758112	0	0	0	0	0	0	0.0	0	0	0	0	0	25753.6	0	27709.9
Mar 9 2020	14174	1304	0	71499640	5758112	0	0	0	0	0	0	0.0	0	0	0	0	0	25753.6	0	27709.9
Mar 10 2020	14194	1324	20	71577396	5835868	77756	2203	896	43	54.9	0.6	1.4	1	-6	833	956	1.5	25755.1	0	27709.9
Mar 11 2020	14326	1456	132	72117952	6376424	540556	15313	899	291	53.2	1.2	10	1	-3	888	937	0	25755.1	9.9	27719.8
Mar 12 2020	14626	1756	300	73414392	7672864	1296440	36726	900	660	50.3	1.9	24	0	876	900	928	0	25755.1	23.1	27742.9
Mar 13 2020	14912	2042	286	74709620	8968092	1295228	36691	900	628	47.9	2.6	24	0	879	900	920	0	25755.1	24.1	27767.7
Mar 14 2020	15198	2328	286	76005669	10264141	1296049	36714	900	629	47.9	2.5	24	0	872	900	924	0	25755.1	24.1	27791.1
Mar 15 2020	15495	2625	297	77298981	11557453	1293312	36637	900	652	49.8	2	24	1	0	899	920	0	25755.1	24.3	27815.4
Mar 16 2020	15793	2923	298	78595878	12854350	1296897	36738	901	656	50	1.9	24	0	866	900	936	0	25755.1	23.2	27838.6
Mar 17 2020	16086	3216	293	79893092	14151564	1297214	36747	901	644	49	2.3	24	0	866	900	938	0	25755.1	24.2	27862.8
Mar 18 2020	16376	3506	290	81186328	15444800	1293236	36635	900	637	48.7	2.4	23.9	1	881	900	914	0	25755.1	23.2	27886
Mar 19 2020	16660	3790	284	82481232	16739704	1294904	36682	899	625	47.7	2.7	24	0	872	900	916	0	25755.1	24.6	27910.6
Mar 20 2020	16945	4075	285	83777611	18036083	1296379	36724	900	626	47.7	2.7	24	0	868	900	933	0	25755.1	24	27934.6
Mar 21 2020	17237	4367	292	85073261	19331733	1295650	36703	900	643	49	2.3	24	0	870	900	927	0	25755.1	24.1	27958.7
Mar 22 2020	17533	4663	296	86369732	20628204	1296471	36726	900	650	49.6	2.1	24	0	871	900	925	0	25755.1	23.1	27981.8
Mar 23 2020	17828	4958	295	87662763	21921235	1293031	36629	899	649	49.6	2.1	23.9	1	860	900	1034	0	25755.1	24.1	28005.9
Mar 24 2020	18130	5260	302	88958222	23216694	1295459	36698	900	664	50.7	1.8	24	0	875	900	923	0	25755.1	24.2	28030.1
Mar 25 2020	18317	5447	187	89777991	24036463	819769	23222	900	411	49.5	2.1	15.2	0	865	900	923	0	25755.1	15.2	28045.3
Mar 26 2020	18317	5447	0	89777991	24036463	0	0	0	0	0	0	0.0	0	0	0	0	0	0	0	0
Mar 27 2020	18317	5447	0	89777991	24036463	0	0	0	0	0	0	0.0	0	0	0	0	0	0	0	0
Mar 28 2020	18317	5447	0	89777991	24036463	0	0	0	0	0	0	0.0	0	0	0	0	0	0	0	0
Mar 29 2020	18454	5584	137	90346149	24604621	568158	16095	899	302	52.5	1.5	10.5	1	-1	893	957	0	25755.1	10.5	28103
Mar 30 2020	18454	5584	0	90346149	24604621	0	0	0	0	0	0	0.0	0	0	0	0	0	0	0	0
Mar 31 2020	18555	5685	101	90753887	25012359	407738	11550	899	222	53.8	1.1	7.6	1	12	888	935	0	25755.1	7.5	28110.4
Apr 1 2020	18664	309	309	92049676	1295789	1295789	36707	900	679	51.8	1.6	24	0	869	900	927	0	25755.1	23.1	28133.5
Apr 2 2020	19144	589	280	93227866	2473979	1178190	33376	899	616	51.7	1.6	21.8	1	-7	896	962	0	25755.1	22	28155.6
Apr 3 2020	19449	894	305	94523478	3769591	1295612	36702	900	670	51.1	1.7	24	0	862	900	930	0	25755.1	24.2	28179.8
Apr 4 2020	19753	1198	304	95818958	5065071	1295480	36698	900	668	51	1.7	24	0	868	900	927	0	25755.1	24.1	28203.9
Apr 5 2020	20059	1504	306	97115747	6361860	1296789	36735	901	672	51.2	1.6	24	0	868	900	931	0	25755.1	23.2	28227.1
Apr 6 2020	20369	1814	310	98411688	7657801	1295941	36711	900	681	52	1.4	24	0	881	900	917	0	25755.1	24.2	28251.3
Apr 7 2020	20677	2122	308	99707379	8953492	1295691	36704	900	678	51.7	1.5	24	0	870	900	939	0	25755.1	24.1	28275.4
Apr 8 2020	20982	2427	305	101004367	10250480	1296988	36741	901	671	51.1	1.6	24	0	858	900	941	0	25755.1	24.1	28299.5
Apr 9 2020	21276	2721	294	102268561	11514674	1264194	35812	899	647	50.6	1.7	23.4	1	73	897	967	0	25755.1	22.6	28322.1
Apr 10 2020	21584	3029	308	103565062	12811175	1296501	36727	900	676	51.6	1.4	24	0	869	900	952	0	25755.1	24.1	28346.2
Apr 11 2020	21885	3330	301	104861376	14107489	1296314	36722	900	662	50.5	1.7	24	0	872	900	931	0	25755.1	24.2	28370.4
Apr 12 2020	22184	3629	299	106156990	15403103	1295614	36702	900	657	50.1	1.8	24	0	867	900	943	0	25755.1	24.1	28394.5
Apr 13 2020	22482	3927	298	107452924	16699037	1295934	36711	900	656	50	1.8	24	0	873	900	925	0	25755.1	23.1	28417.6
Apr 14 2020	22779	4224	297	108745731	17991844	1292807	36623	900	653	49.9	1.8	23.9	1	0	899	935	0	25755.1	24.5	28442.1
Apr 15 2020	23076	4521	297	110041419	19287532	1295688	36704	900	652	49.8	1.8	24	0	864	900	933	0	25755.1	24.2	28466.3
Apr 16 2020	23371	4816	295	111337401	20583514	1295982	36713	900	650	49.5	1.8	24	0	865	900	947	0	25755.1	23.1	28489.4
Apr 17 2020	23674	5119	303	112633194	21879307	1295793	36707	900	665	50.7	1.6	24	0	850	900	943	0	25755.1	24.2	28513.7
Apr 18 2020	23970	5415	296	113930164	23176277	1296970	36741	901	650	49.6	1.9	24	0	870	900	927	0	25755.1	24.1	28537.8
Apr 19 2020	24267	5712	297	115228678	24472791	1296514	36728	900	653	49.8	1.8	24	0	842	900	936	0	25755.1	24.1	28561.9
Apr 20 2020	24560	6005	293	116522371	25768484	1295693	36704	900	645	49.2	2	24	0	874	900	928	0	25755.1	23.2	28585.1
Apr 21 2020	24853	6298	293	117818840	27064953	1296469	36726	900	645	49.2	1.9	24	0	865	900	938	0	25755.1	24.1	28609.2
Apr 22 2020	25148	6593	295	119104849	28350962	1286009	36430	899	649	49.9	1.8	23.8	1	290	899	939	0	25755.1	24	28633.2
Apr 23 2020	25445	6890	297	120400426	29646539	1295577	36701	900	654	49.9	1.8	24	0	870	900	948	0	25755.1	24.2	28657.4
Apr 24 2020	25738	7183	293	121696047	30942160	1295621	36702	900	645	49.2	1.9	24	0	872	900	932	0	25755.1	23.2	28680.6
Apr 25 2020	26032	7477	294	122993253	32239366	1297206	36747	901	647	49.3	1.9	24	0	880	900	927	0	25755.1	24.1	28704.7
Apr 26 2020	26332	7777	300	124289107	33535220	1295854	36709	900	660	50.3	1.6	24	0	841	900	955	0	25755.1	24.1	28728.8
Apr 27 2020	26631	8076	299	125584502	34830615	1295395	36696	900	657	50.2	1.7	24	0	868	900	945	0	25755.1	24.2	28753
Apr 28 2020	26928	8373	297	126879839	36125952	1295337	36694	900	652	49.8	1.8	24	0	868	900	932	0	25755.1	23	28776
Apr 29 2020	27222	8667	294	128175798	37421911	1295959	36712	900	647	49.4	1.9	24	0	870	900	930	0	25755.1	24.2	28800.2
Apr 30 2020	27524	8969	302	129471568	38717681	1295770	36707	900	665	50.7	1.6	24	0	873	900	935	0	25755.1	24.1	28824.3
May 1 2020	27829	305	305	130767354	1295786	1295786	36707	900	671	51.1	1.5	24	0	862	900	932	0	25755.1	24.2	28848.5
May 2 2020	28015	491	186	131554654	2083086	787300	22303	899	410	51.5	1.4	14.6	1	7	894	951	0	25755.1	13.7	28862.3
May 3 2020	28313	789	298	132850108	3378540	1295454	36698	900	656	50.1	1.8	24	0	876	900	925	0	25755.1	24.1	28886.4
May 4 2020	28614	1090	301	134146621	4675053	1296513	36728	900	662	50.4	1.6	24	0	870	900	927	0	25755.1	24.2	28910.6
May 5 2020	28707	1183	93	134547669	5076101	401048	11361	901	205	50.5	1.6	7.4	0	861	900	934	0	25755.1	7	28917.6
May 6 2020	28707	1183	0	134547669	5076101	0	0	0	0	0	0	0.0	0	0	0	0	0	0	0	0
May 7 2020	28818	1294	111	135033126																

Date	CO2 Equivalents			Landfill Gas Flow						Methane	Oxygen	Flare	Flare	Temperature			Blower 1		Blower 2	
	Yearly	Monthly	Daily	Yearly	Monthly	Daily	Daily	Avg	Total	Avg	Avg	Run Hours	Starts	Min.	Avg.	Max.	Daily	Cumu.	Daily	Cumu.
	Tonnes CO2	Tonnes CO2	Tonnes CO2	scf	scf	scf	meter3	scfm	MMBTU	(%)	(%)			°C	°C	°C	Hours	Hours	Hours	Hours
May 14 2020	30484	2960	135	142315312	12843744	562342	15930	899	298	52.3	1.3	10.5	1	7	891	944	0	25755.1	10.3	29117
May 15 2020	30782	3258	298	143610971	14139403	1295659	36703	900	656	50	1.8	24	0	872	900	922	0	25755.1	23.2	29140.2
May 16 2020	31079	3555	297	144907016	15435448	1296045	36714	900	654	49.9	1.9	24	0	854	900	936	0	25755.1	24.1	29164.3
May 17 2020	31378	3854	299	146202590	16731022	1295574	36701	900	658	50.2	1.8	24	0	863	900	939	0	25755.1	24.1	29188.4
May 18 2020	31586	4062	208	147108975	17637407	906385	25676	900	457	49.9	1.8	16.7	0	855	900	944	0	25755.1	17.1	29205.5
May 19 2020	31729	4205	143	147691726	18220158	582751	16508	900	315	53.4	0.9	10.8	1	24	892	955	0	25755.1	10.5	29216
May 20 2020	32041	4517	312	148988545	19516977	1296819	36736	901	686	52.3	1.1	24	0	854	900	945	0	25755.1	24.1	29240.1
May 21 2020	32354	4830	313	150282590	20811022	1294045	36658	900	688	52.6	0.8	23.9	1	852	900	948	0	25755.1	23.5	29263.6
May 22 2020	32665	5141	311	151579146	22107578	1296556	36729	900	683	52.1	0.9	24	0	849	900	946	0	25755.1	24.1	29287.7
May 23 2020	32974	5450	309	152874409	23402841	1295263	36692	900	680	51.9	0.9	24	0	833	900	946	0	25755.1	24.2	29311.9
May 24 2020	33184	5660	210	154171215	24699647	1296806	36736	901	462	35.2	7.4	24	0	864	900	939	0	25755.1	23.2	29335.1
May 25 2020	33490	5966	306	155467567	25995999	1296352	36723	900	672	51.3	0.9	24	0	872	900	930	0	25755.1	24.1	29359.2
May 26 2020	33796	6272	306	156761218	27289650	1293651	36647	900	674	51.5	0.8	23.9	1	0	899	934	0	25755.1	24	29383.2
May 27 2020	34100	6576	304	158057186	28585618	1295968	36712	900	669	51.1	1.1	24	0	847	900	950	0	25755.1	24.2	29407.4
May 28 2020	34401	6877	301	159351577	29880009	1294391	36668	899	661	50.5	1.1	24	0	859	900	942	0	25755.1	23.1	29430.6
May 29 2020	34698	7174	297	160648205	31176637	1296628	36731	900	653	49.8	1.1	24	0	864	900	929	0	25755.1	24.2	29454.8
May 30 2020	34996	7472	298	161944289	32472721	1296084	36715	900	656	50	0.9	24	0	856	900	943	0	25755.1	24.1	29478.9
May 31 2020	35300	7776	304	163240072	33768504	1295783	36707	900	668	50.9	0.8	24	0	856	900	940	0	25755.1	24.1	29503
Jun 1 2020	35607	807	307	164534484	1294782	1294782	36679	899	675	51.5	0.6	24	0	853	900	967	0	25755.1	23.2	29526.2
Jun 2 2020	35908	808	301	165830603	2590531	1295749	36706	900	663	50.5	0.9	24	0	849	900	946	0	25755.1	24.1	29550.3
Jun 3 2020	36212	912	304	167126639	3886567	1296036	36714	900	669	51	0.7	24	0	836	900	958	0	25755.1	24.2	29574.5
Jun 4 2020	36514	1214	302	168422694	5182622	1296055	36715	900	665	50.7	0.8	24	0	847	900	963	0	25755.1	24.1	29598.6
Jun 5 2020	36808	1508	294	169717502	6477430	1294808	36679	899	647	49.4	1.1	24	0	875	900	933	0	25755.1	23.1	29621.7
Jun 6 2020	37104	1804	296	171013132	7773060	1295630	36703	900	652	49.7	0.9	24	0	877	900	918	0	25755.1	24.2	29645.9
Jun 7 2020	37410	2110	306	172309012	9068940	1295880	36710	900	674	51.4	0.5	24	0	837	900	937	0	25755.1	24.1	29670
Jun 8 2020	37714	2414	304	173604891	10364819	1295879	36710	900	670	51.1	0.6	24	0	864	900	930	0	25755.1	24.1	29694.1
Jun 9 2020	38015	2715	301	174899972	11659900	1295081	36687	899	661	50.5	0.7	24	0	870	900	925	0	25755.1	24.1	29718.2
Jun 10 2020	38312	3012	297	176181058	12940986	1281086	36291	900	654	50.5	0.8	23.7	1	197	897	946	0	25755.1	22.9	29741.1
Jun 11 2020	38605	3305	293	177476787	14236715	1295729	36705	900	643	49.1	1.1	24	0	868	900	922	0	25755.1	24.1	29765.2
Jun 12 2020	38897	3597	292	178772680	15532608	1295893	36710	900	643	49.1	1.1	24	0	880	900	916	0	25755.1	24.1	29789.4
Jun 13 2020	39196	3896	299	180068903	16828831	1296223	36719	900	659	50.2	0.8	24	0	857	900	922	0	25755.1	24.2	29813.6
Jun 14 2020	39499	4199	303	181365017	18124945	1296114	36716	900	666	50.8	0.7	24	0	882	900	916	0	25755.1	23.1	29836.7
Jun 15 2020	39802	4502	303	182661309	19421237	1296292	36721	900	667	50.8	0.7	24	0	841	900	970	0	25755.1	24.1	29860.8
Jun 16 2020	40106	4806	304	183966679	20716607	1295370	36695	900	668	51	0.7	24	0	870	900	924	0	25755.1	24.1	29884.9
Jun 17 2020	40345	5045	239	184978746	21738674	1022067	526	698	50.9	0.8	18.9	0	847	900	942	0	25755.1	19.4	29904.3	
Jun 18 2020	40521	5221	176	185702458	22462386	723712	20501	898	387	52.8	0.7	13.4	2	71	892	958	0	25755.1	12.5	29916.8
Jun 19 2020	40662	5362	141	186303929	23063857	601471	17038	899	309	50.8	0.8	11.1	0	868	900	938	0	25755.1	12.1	29928.8
Jun 20 2020	40823	5523	161	186950641	23710569	646712	18320	899	355	54.2	0.5	12	1	18	892	935	0	25755.1	11.6	29940.4
Jun 21 2020	40952	5652	129	187478583	24238511	527942	14956	900	283	52.9	0.6	9.7	0	858	900	929	0	25755.1	10.1	29950.4
Jun 22 2020	41122	5822	170	188168839	24928767	690256	19554	899	374	53.5	0.8	12.8	1	16	894	948	0	25755.1	12.1	29962.5
Jun 23 2020	41433	6133	311	189461767	26221695	1292928	36626	900	684	52.3	0.9	23.9	1	868	900	945	0	25755.1	24.3	29986.8
Jun 24 2020	41741	6441	308	190757955	27517883	1296188	36718	900	677	51.6	0.9	24	0	866	900	935	0	25755.1	24.2	30011
Jun 25 2020	42042	6742	301	192054090	28814018	1296135	36717	900	662	50.4	1	24	0	859	900	931	0	25755.1	23.1	30034.1
Jun 26 2020	42336	7036	294	193349831	30109759	1295741	36706	900	646	49.3	1.2	24	0	862	900	936	0	25755.1	24.2	30058.3
Jun 27 2020	42631	7331	295	194645598	31405526	1295767	36706	900	648	49.4	1.1	24	0	869	900	927	0	25755.1	24.1	30082.4
Jun 28 2020	42923	7623	292	195941436	32701364	1295838	36708	900	641	48.9	1.2	24	0	860	900	928	0	25755.1	23.2	30105.6
Jun 29 2020	43211	7911	288	197237159	33997087	1295723	36705	900	632	48.2	1.3	24	0	878	900	926	0	25755.1	24.2	30129.8
Jun 30 2020	43500	8200	289	198533429	35293357	1296270	36721	900	635	48.4	1.4	24	0	873	900	942	0	25755.1	24.1	30153.9
Jul 1 2020	43790	8490	290	199829158	1295729	1295729	36705	900	638	48.7	1.6	24	0	857	900	945	0	25755.1	24.2	30178.1
Jul 2 2020	44081	8780	291	201125401	2591972	1296243	36720	900	640	48.8	1.6	24	0	874	900	926	0	25755.1	23.2	30201.3
Jul 3 2020	44372	9070	291	202421772	3888343	1296371	36724	900	639	48.7	1.6	24	0	861	900	935	0	25755.1	24.2	30225.5
Jul 4 2020	44673	9360	201	203317499	4784070	895727	25374	900	443	48.9	1.3	16.5	0	861	900	936	0	25755.1	17.1	30242.7
Jul 5 2020	44729	1229	156	203970758	5437329	653259	18506	899	343	51.8	1.2	12.1	1	50	893	945	0	25755.1	12	30254.6
Jul 6 2020	45027	1527	298	205266856	6733427	1296098	36716	900	655	49.9	1.5	24	0	867	900	942	0	25755.1	23.1	30277.7
Jul 7 2020	45323	1823	296	206562169	8028740	1295313	36694	900	652	49.7	1.4	24	0	853	900	946	0	25755.1	24.2	30301.9
Jul 8 2020	45621	2121	298	207857336	9323907	1295167	36690	899	655	50	1.2	24	0	861	900	939	0	25755.1	24.1	30326
Jul 9 2020	45908	2408	287	209154211	10620782	1296875	36738	901	631	48.1	1.8	24	0	847	900	963	0	25755.1	24.2	30350.3
Jul 10 2020	46189	2689	281	210451009	11917580	1296798	36736	901	619	47.2	1.8	24	0	863	900	938	0	25755.1	23.1	30373.4
Jul 11 2020	46377	2877	188	211286453	12753024	835444	23666	899	414	49	1.5	15.5	1	30	897					

Date	CO2 Equivalents			Landfill Gas Flow						Methane	Oxygen	Flare	Flare	Temperature			Blower 1		Blower 2	
	Yearly	Monthly	Daily	Yearly	Monthly	Daily	Daily	Avg	Total	Avg	Avg	Run Hours	Starts	Min.	Avg.	Max.	Daily	Cumu.	Daily	Cumu.
	Tonnes CO2	Tonnes CO2	Tonnes CO2	scf	scf	scf	meter3	scfm	MMBTU	(%)	(%)			°C	°C	°C	Hours	Hours	Hours	Hours
Jul 20 2020	48592	5092	272	221451032	22917603	1295488	36699	900	599	45.7	2.1	24	0	850	900	946	0	25755.1	23.2	30576.4
Jul 21 2020	48867	5367	275	222747213	24213784	1296181	36718	900	605	46.1	1.8	24	0	871	900	920	0	25755.1	24.2	30600.6
Jul 22 2020	49141	5641	274	224042286	25508857	1295073	36687	899	603	46	1.8	24	0	867	900	926	0	25755.1	24.1	30624.7
Jul 23 2020	49415	5915	274	225322574	26789145	1280288	36268	899	602	46.5	1.6	23.7	1	168	897	958	0	25755.1	23.7	30648.4
Jul 24 2020	49693	6193	278	226609289	28075860	1286715	36450	900	612	47	1.6	23.8	1	355	899	941	0	25755.1	24	30672.4
Jul 25 2020	49969	6469	276	227905616	29372187	1296327	36722	900	607	46.3	1.8	24	0	869	900	925	0	25755.1	23.2	30695.6
Jul 26 2020	50240	6740	271	229202066	30668637	1296450	36726	900	596	45.4	1.8	24	0	870	900	931	0	25755.1	24.2	30719.8
Jul 27 2020	50512	7012	272	230498781	31965352	1296715	36733	901	598	45.6	1.8	24	0	863	900	935	0	25755.1	24.1	30743.9
Jul 28 2020	50783	7283	271	231795291	33261862	1296510	36728	900	595	45.3	1.8	24	0	872	900	927	0	25755.1	23.3	30767.2
Jul 29 2020	51050	7550	267	233090091	34556662	1294800	36679	899	587	44.8	2	24	0	864	900	942	0	25755.1	24.2	30791.4
Jul 30 2020	51315	7815	265	234386351	35852922	1296260	36720	900	584	44.5	2	24	0	862	900	938	0	25755.1	24.2	30815.6
Jul 31 2020	51582	8082	267	235683062	37149633	1296711	36733	900	588	44.8	1.9	24	0	870	900	940	0	25755.1	23.1	30838.7
Aug 1 2020	51657	75	75	236052616	369554	369554	10469	901	164	44	2.1	6.8	0	888	900	910	0	25755.1	7.9	30846.6
Aug 2 2020	51794	212	137	236648912	965800	596296	16892	899	301	49.9	1.5	11.1	1	35	893	964	0	25755.1	10.6	30857.2
Aug 3 2020	52070	488	276	237944463	2261401	1295551	36700	900	608	46.4	1.9	24	0	864	900	926	0	25755.1	24.2	30881.4
Aug 4 2020	52340	758	270	239237692	3554630	1293229	36635	900	594	45.4	2.1	23.9	1	0	899	951	0	25755.1	23.1	30904.5
Aug 5 2020	52610	1028	270	240533736	4850674	1296044	36714	900	594	45.3	2.1	24	0	876	900	938	0	25755.1	24.2	30928.7
Aug 6 2020	52874	1292	264	241819438	6136376	1285702	36421	899	582	44.7	2.3	23.8	1	262	897	962	0	25755.1	24	30952.7
Aug 7 2020	53141	1559	267	243115245	7432183	1295807	36708	900	587	44.7	2.2	24	0	877	900	923	0	25755.1	24.2	30976.9
Aug 8 2020	53402	1820	261	244411768	8728706	1296523	36728	900	574	43.8	2.5	24	0	867	900	927	0	25755.1	23.2	31000.1
Aug 9 2020	53663	2081	261	245708890	10025828	1297122	36745	901	574	43.8	2.5	24	0	858	900	926	0	25755.1	24.2	31024.3
Aug 10 2020	53921	2339	258	247005121	11322059	1296231	36720	900	567	43.2	2.7	24	0	865	900	933	0	25755.1	24.2	31048.5
Aug 11 2020	54126	2544	205	248041958	12358896	1036837	29372	899	451	43	3	19.2	2	34	893	947	0	25755.1	18.4	31066.9
Aug 12 2020	54361	2779	235	249272962	13589900	1231004	34872	900	518	41.6	3.4	22.8	1	64	897	973	0	25755.1	23	31090
Aug 13 2020	54603	3021	242	250569355	14886293	1296393	36724	900	531	40.5	3.7	24	0	860	900	925	0	25755.1	24.2	31114.2
Aug 14 2020	54843	3261	240	251865728	16182666	1296373	36724	900	529	40.3	3.7	24	0	866	900	927	0	25755.1	23.2	31137.4
Aug 15 2020	55086	3504	243	253161628	17478566	1295900	36710	900	534	40.7	3.6	24	0	861	900	935	0	25755.1	24.2	31161.6
Aug 16 2020	55325	3743	239	254457182	18774120	1295554	36700	900	526	40.1	3.8	24	0	862	900	928	0	25755.1	24.2	31185.8
Aug 17 2020	55563	3981	238	255753726	20070664	1296544	36728	900	523	39.9	4.1	24	0	856	900	940	0	25755.1	24.1	31209.9
Aug 18 2020	55806	4224	243	257049731	21366669	1296005	36713	900	535	40.8	4	24	0	863	900	941	0	25755.1	23.2	31233.1
Aug 19 2020	56038	4456	232	258279873	22596811	1230142	34847	899	511	41	4.1	22.8	1	78	897	947	0	25755.1	23	31256.1
Aug 20 2020	56281	4699	243	259575440	23892378	1295567	36701	900	535	40.8	4.2	24	0	877	900	923	0	25755.1	24.1	31280.2
Aug 21 2020	56524	4942	243	260871643	25188581	1296203	36719	900	536	40.8	4.3	24	0	878	900	922	0	25755.1	24.2	31304.4
Aug 22 2020	56766	5184	242	262167911	26484849	1296268	36721	900	532	40.5	4.3	24	0	873	900	921	0	25755.1	23.2	31327.6
Aug 23 2020	57006	5424	240	263464012	27780950	1296101	36716	900	528	40.3	4.5	24	0	865	900	923	0	25755.1	24.2	31351.8
Aug 24 2020	57244	5662	238	264760491	29077429	1296479	36727	900	524	40	4.6	24	0	846	900	925	0	25755.1	24.2	31376
Aug 25 2020	57407	5825	163	265587600	29904538	827109	23430	900	359	42.9	4	15.3	1	60	895	951	0	25755.1	14.5	31390.5
Aug 26 2020	57665	6083	258	266884108	31201046	1296508	36727	900	568	43.3	3.5	24	0	862	900	924	0	25755.1	24.2	31414.7
Aug 27 2020	57930	6348	265	268180131	32497069	1296023	36714	900	583	44.4	2.6	24	0	865	900	920	0	25755.1	24.2	31438.9
Aug 28 2020	58174	6592	244	269378676	33695614	1198545	33952	899	537	44.3	2.7	22.2	1	28	894	957	0	25755.1	22.4	31461.3
Aug 29 2020	58439	6857	265	270674861	34991799	1296185	36718	900	582	44.4	2.6	24	0	856	900	931	0	25755.1	23.1	31484.4
Aug 30 2020	58581	6999	142	271352695	35669633	677834	19202	900	313	45.6	2.3	12.5	0	876	900	918	0	25755.1	13.4	31497.8
Aug 31 2020	58581	6999	0	271352695	35669633	0	0	0	0	0	0	0	0	0	0	0	0	25755.1	0	31497.8
Sep 1 2020	58738	157	157	272026999	674304	674304	19102	899	345	50.5	1.4	12.5	1	9	892	968	0	25755.1	11.9	31509.6
Sep 2 2020	59022	441	284	273322292	1969597	1295293	36693	900	624	47.6	1.9	24	0	854	900	935	0	25755.1	24.2	31533.8
Sep 3 2020	59295	714	273	274618199	3265504	1295907	36710	900	601	45.8	2.2	24	0	868	900	928	0	25755.1	24.2	31558
Sep 4 2020	59560	979	265	275894638	4541943	1276439	36159	901	583	45.1	2.2	23.6	0	868	900	934	0	25755.1	23.1	31581.1
Sep 5 2020	59560	979	0	275894638	4541943	0	0	0	0	0	0	0	0	0	0	0	0	25755.1	0.4	31581.5
Sep 6 2020	59560	979	0	275894638	4541943	0	0	0	0	0	0	0	0	0	0	0	0	25755.1	0	31581.5
Sep 7 2020	59635	1054	75	276243347	4890652	348709	9878	898	165	46.9	3.4	6.5	1	10	886	928	0	25755.1	6.5	31588
Sep 8 2020	59774	1193	139	276893070	5540375	649723	18405	898	306	46.6	3.4	12.1	1	10	891	953	0	25755.1	11.2	31599.2
Sep 9 2020	60042	1461	268	278189147	6836452	1296077	36715	900	589	44.9	3.8	24	0	854	900	929	0	25755.1	24.1	31623.3
Sep 10 2020	60302	1721	260	279484149	8131454	1295002	36685	899	572	43.7	4.1	24	0	866	900	926	0	25755.1	24.2	31647.5
Sep 11 2020	60553	1972	251	280780301	9427606	1296152	36717	900	553	42.1	4.7	24	0	883	900	916	0	25755.1	24.2	31671.7
Sep 12 2020	60804	2223	251	282076233	10723538	1295932	36711	900	551	42	4.7	24	0	877	900	920	0	25755.1	23.1	31694.8
Sep 13 2020	61046	2465	242	283373512	12020817	1297279	36749	901	533	40.6	4.9	24	0	884	900	911	0	25755.1	24.2	31719
Sep 14 2020	61290	2709	244	284668930	13316235	1295418	36697	900	536	40.9	4.7	24	0	872	900	925	0	25755.1	24.1	31743.1
Sep 15 2020	61523	2942	233	285955051	14602356	1286121	36433	900	514	39.5	4.8	23.8	0	886	900	914	0	25755.1	24.1	31767.2
Sep 16 2020	61649	3068	126	286575883	15223188	620832	17587	900	278	44.3	3.7	11.5	1	9	892	962	0	25755.1	10.7	31779.9
Sep 17 2020	61898	3317	249	287870771																

Date	CO2 Equivalents			Landfill Gas Flow						Methane	Oxygen	Flare	Flare	Temperature			Blower 1		Blower 2	
	Yearly	Monthly	Daily	Yearly	Monthly	Daily	Daily	Avg	Total	Avg	Avg	Run Hours	Starts	Min.	Avg.	Max.	Daily	Cumu.	Daily	Cumu.
	Tonnes CO2	Tonnes CO2	Tonnes CO2	scf	scf	scf	meter3	scfm	MMBTU	(%)	(%)			°C	°C	°C	Hours	Hours	Hours	Hours
Sep 25 2020	63926	5345	256	298240000	26887305	1296137	36717	900	563	42.9	3	24	0	860	900	934	0	25755.1	24.2	31993.4
Sep 26 2020	64181	5600	255	299536577	28183882	1296577	36729	900	560	42.7	2.9	24	0	862	900	942	0	25755.1	24.2	32017.6
Sep 27 2020	64422	5841	241	300831964	29479269	1295387	36696	900	529	40.4	3.5	24	0	863	900	927	0	25755.1	23.2	32040.8
Sep 28 2020	64558	5977	136	301521571	30168876	689607	19535	900	300	43	3.3	12.8	1	10	893	954	0	25755.1	13	32053.8
Sep 29 2020	64814	6233	256	302817896	31465201	1296325	36722	900	563	42.9	3.3	24	0	860	900	935	0	25755.1	24.1	32077.9
Sep 30 2020	65064	6483	250	304114757	32762062	1296881	36737	901	551	42	3.5	24	0	873	900	929	0	25755.1	24.2	32102.1
Oct 1 2020	65308	244	244	305410470	1295713	1295713	36705	900	537	41	3.7	24	0	873	900	928	0	25755.1	23.2	32125.3
Oct 2 2020	65561	497	253	306706834	2582077	1296364	36723	900	556	42.4	3.4	24	0	870	900	924	0	25755.1	24.1	32149.4
Oct 3 2020	65811	747	250	308002917	3888160	1296083	36715	900	550	42	3.6	24	0	867	900	925	0	25755.1	24.2	32173.6
Oct 4 2020	66069	1005	258	309299190	5184433	1296273	36721	900	567	43.2	3.3	24	0	870	900	923	0	25755.1	23.2	32196.8
Oct 5 2020	66326	1262	257	310596005	6481248	1296815	36736	901	566	43.1	3.4	24	0	869	900	942	0	25755.1	24.2	32221
Oct 6 2020	66375	1311	49	310843835	6729078	247830	7021	900	108	43.2	3.2	4.6	0	871	900	928	0	25755.1	5	32226
Oct 7 2020	66375	1311	0	310843835	6729078	0	0	0	0	0	0	0.0	0	0	0	0	0	25755.1	0	32226
Oct 8 2020	66538	1474	163	311657876	7543119	814041	23060	900	359	43.6	3.1	15.1	1	304	896	922	0	25755.1	67.1	32293.1
Oct 9 2020	66789	1725	251	312954311	8839554	1296435	36725	900	552	42.1	3.7	24	0	862	900	931	0	25755.1	23.2	32316.3
Oct 10 2020	67037	1973	248	314250322	10135565	1296011	36713	900	545	41.5	3.9	24	0	871	900	924	0	25755.1	24.2	32340.5
Oct 11 2020	67173	2109	136	314927500	10812743	677178	19183	899	299	43.7	3.5	12.5	0	877	900	918	0	25755.1	13.1	32353.6
Oct 12 2020	67298	2234	125	315517093	11402336	589593	16702	899	275	46.1	3.8	11	1	25	894	967	0	25755.1	10.8	32364.4
Oct 13 2020	67556	2492	258	316812866	12698109	1295773	36707	900	567	43.2	4.7	24	0	860	900	935	0	25755.1	23.2	32387.6
Oct 14 2020	67794	2730	238	318026825	13912068	1213959	34389	900	523	42.5	4.4	22.5	2	46	893	926	0	25755.1	22.7	32410.3
Oct 15 2020	68040	2976	246	319322804	15208047	1295979	36713	900	540	41.2	3.9	24	0	873	900	923	0	25755.1	24.2	32434.5
Oct 16 2020	68287	3223	247	320619728	16504971	1296924	36739	901	543	41.4	3.9	24	0	864	900	932	0	25755.1	23.1	32457.6
Oct 17 2020	68529	3465	242	321915001	17800244	1295273	36693	900	532	40.6	4.1	24	0	874	900	926	0	25755.1	24.2	32481.8
Oct 18 2020	68767	3703	238	323210347	19095590	1295346	36695	900	524	39.9	4.4	24	0	876	900	927	0	25755.1	24.2	32506
Oct 19 2020	69004	3940	237	324505822	20391065	1295475	36698	900	521	39.7	4.6	24	0	869	900	923	0	25755.1	24.2	32530.2
Oct 20 2020	69150	4086	146	325293045	21178288	787223	321	40.3	22.900	42.5	14.6	0	872	900	916	0	25755.1	14.6	32544.8	
Oct 21 2020	69319	4255	169	326131837	22017080	838792	23761	899	372	43.8	5.2	15.6	1	-7	893	967	0	25755.1	14.7	32559.6
Oct 22 2020	69562	4498	243	327426819	23312062	1294982	36684	899	533	40.7	4.9	24	0	882	900	918	0	25755.1	24.2	32583.8
Oct 23 2020	69805	4741	243	328722558	24607801	1295739	36706	900	534	40.8	4	24	0	875	900	925	0	25755.1	24.2	32608
Oct 24 2020	70045	4981	240	330019400	25904643	1296842	36737	901	528	40.3	4.1	24	0	821	900	931	0	25755.1	23.1	32631.1
Oct 25 2020	70284	5220	239	331315702	27200945	1296302	36722	900	526	40.1	4.3	24	0	871	900	928	0	25755.1	24.2	32655.3
Oct 26 2020	70527	5463	243	332611587	28496830	1295885	36710	900	533	40.7	4.2	24	0	873	900	920	0	25755.1	24.2	32679.5
Oct 27 2020	70773	5709	246	333906988	29792231	1295401	36696	900	542	41.3	4.2	24	0	882	900	920	0	25755.1	24.2	32703.7
Oct 28 2020	70953	5889	180	334920990	30806233	1014002	28725	900	396	38.6	5.3	18.8	0	866	900	922	0	25755.1	18.8	32722.5
Oct 29 2020	71057	5993	104	335419951	31305194	498961	14135	900	229	45.3	3.3	9.3	1	52	893	953	0	25755.1	8.5	32731
Oct 30 2020	71311	6247	254	336714707	32599950	1294756	36678	899	559	42.6	3.8	24	0	876	900	915	0	25755.1	24.2	32755.2
Oct 31 2020	71550	6486	239	337986181	33871424	1271474	36018	899	526	40.9	4.5	23.5	1	93	891	923	0	25755.1	24	32779.2
Nov 1 2020	71797	247	247	339282135	1295954	1295954	36712	900	543	41.4	3.8	24	0	881	900	922	0	25755.1	24.6	32803.8
Nov 2 2020	72047	497	250	340565612	2579431	1283477	36358	900	551	42.4	3.5	23.7	2	0	897	954	0	25755.1	24.5	32828.3
Nov 3 2020	72301	751	254	341861566	3875385	1295954	36712	900	560	42.7	3.6	24	0	870	900	932	0	25755.1	24.7	32853
Nov 4 2020	72543	993	242	343156340	5170159	1294774	36678	899	533	40.7	4.4	24	0	864	900	929	0	25755.1	24.6	32877.6
Nov 5 2020	72786	1236	243	344450872	6464691	1294532	36672	899	535	40.9	4.1	24	0	856	900	941	0	25755.1	23.6	32901.1
Nov 6 2020	73034	1484	248	345743298	7757117	1292426	36612	900	546	41.8	3.4	23.7	1	867	900	936	0	25755.1	25.1	32926.2
Nov 7 2020	73086	1536	52	346008654	8022473	265356	7517	902	115	42.7	2.9	4.9	0	884	900	914	0	25755.1	5.2	32931.4
Nov 8 2020	73086	1536	0	346008654	8022473	0	0	0	0	0	0	0.0	0	0	0	0	0	25755.1	0	32931.4
Nov 9 2020	73189	1639	103	346556656	8570475	548002	15524	900	226	40.8	3.3	10.1	1	271	900	935	0	25755.1	67.8	32999.2
Nov 10 2020	73435	1885	246	347853586	9867405	1296930	36739	901	540	41.2	3.1	24	0	824	900	946	0	25755.1	23.7	33022.9
Nov 11 2020	73679	2129	244	349147976	11161795	1294390	36667	899	537	41	3.2	24	0	876	900	929	0	25755.1	24.7	33047.6
Nov 12 2020	73913	2363	234	350443098	12456917	1295122	36688	899	515	39.3	3.5	24	0	864	900	928	0	25755.1	24.7	33072.3
Nov 13 2020	74158	2608	245	351738257	13752076	1295159	36689	899	540	41.2	3	24	0	863	900	930	0	25755.1	23.6	33095.8
Nov 14 2020	74265	2715	107	352297841	14311660	559584	15852	900	236	41.7	3	10.4	0	884	900	914	0	25755.1	11.4	33107.2
Nov 15 2020	74265	2715	0	352297841	14311660	0	0	0	0	0	0	0.0	0	0	0	0	0	25755.1	0	33107.2
Nov 16 2020	74401	2851	136	353090129	15103948	792288	22444	901	299	37.3	4	14.6	1	866	900	925	0	25755.1	62.3	33169.4
Nov 17 2020	74631	3081	230	354385312	16399131	1295183	36690	899	505	38.5	3.7	24	0	848	900	945	0	25755.1	24.6	33194
Nov 18 2020	74844	3294	213	355504942	17158761	1119630	31717	899	468	41.3	3.1	20.7	1	3	898	1058	0	25755.1	21.3	33215.4
Nov 19 2020	75053	3503	209	356680742	18694561	1175800	33308	900	459	38.6	3.8	21.8	1	24	896	919	0	25755.1	21.3	33236.7
Nov 20 2020	75274	3724	221	357975837	19989656	1295095	36687	899	485	37	4	24	0	876	898	917	0	25755.1	24.6	33261.3
Nov 21 2020	75504	3954	230	359271564	21285383	1295727	36705	900	506	38.6	3.7	24	0	872	900	923	0	25755.1	24.6	33285.8
Nov 22 2020	75728	4178	224	360567636	22581455	1296072	36715	900	493	37.6	3.9	24	0	870	900	928	0	25755.1	24.7	33310.5
Nov 23 2020	75956	4406	228	361863788																

Date	CO2 Equivalents			Landfill Gas Flow						Methane	Oxygen	Flare	Flare	Temperature			Blower 1		Blower 2	
	Yearly	Monthly	Daily	Yearly	Monthly	Daily	Avg	Total	Avg	Avg	Run Hours	Starts	Min.	Avg.	Max.	Daily	Cumu.	Daily	Cumu.	
	Tonnes CO2	Tonnes CO2	Tonnes CO2	scf	scf	scf	meter3	scfm	MMBTU	(%)	(%)			°C	°C	°C	Hours	Hours	Hours	Hours
Dec 1 2020	77621	206	206	371141926	1152114	1152114	32637	800	452	38.8	3.7	24	0	875	900	920	0	25755.1	24.6	33529.3
Dec 2 2020	77828	413	207	372293813	2304001	1151887	32631	800	456	39.1	3.7	24	0	875	900	915	0	25755.1	24.7	33554
Dec 3 2020	78047	632	219	373444974	3455162	1151161	32610	799	481	41.3	3	24	0	879	900	933	0	25755.1	24.6	33578.5
Dec 4 2020	78271	856	224	374597795	4607983	1152821	32657	801	493	42.2	2.5	24	0	862	900	927	0	25755.1	24.6	33603.1
Dec 5 2020	78389	974	118	375196077	5206265	598282	16948	800	260	42.9	2.3	12.4	1	872	900	918	0	25755.1	12.8	33615.9
Dec 6 2020	78389	974	0	375196077	5206265	0	0	0	0	0	0	0.0	0	0	0	0	0	25755.1	0	33615.9
Dec 7 2020	78496	1081	107	375676042	5686230	479965	13596	799	234	48.2	1.8	10	1	0	890	930	0	25755.1	9.6	33625.5
Dec 8 2020	78746	1331	250	376828503	6838691	1152461	32647	800	549	47.1	2.4	24	0	880	900	920	0	25755.1	24.5	33649.9
Dec 9 2020	78991	1576	245	377979987	7990175	1151484	32619	800	538	46.2	2.8	24	0	872	900	923	0	25755.1	24.4	33674.3
Dec 10 2020	79233	1818	242	379131111	9141299	1151124	32609	799	532	45.7	3.1	24	0	886	900	916	0	25755.1	24.6	33698.9
Dec 11 2020	79476	2061	243	380284207	10294395	1153096	32665	801	535	45.9	3.1	24	0	877	900	921	0	25755.1	24.7	33723.6
Dec 12 2020	79722	2307	246	381436714	11446902	1152507	32648	800	540	46.3	3	24	0	873	900	921	0	25755.1	23.6	33747.1
Dec 13 2020	79965	2550	243	382588403	12598591	1151689	32625	800	536	46	3.2	24	0	861	900	922	0	25755.1	24.7	33771.8
Dec 14 2020	80204	2789	239	383740835	13751023	1152432	32646	800	525	45	3.5	24	0	869	900	922	0	25755.1	24.6	33796.4
Dec 15 2020	80449	3034	245	384891201	14901389	1150366	32588	799	539	46.3	3.2	24	0	880	900	917	0	25755.1	24.7	33821.1
Dec 16 2020	80694	3279	245	386043642	16053830	1152441	32646	800	539	46.2	3.2	24	0	888	900	910	0	25755.1	23.6	33844.6
Dec 17 2020	80937	3522	243	387196770	17206958	1153128	32666	801	534	45.8	3.3	24	0	882	900	923	0	25755.1	24.7	33869.3
Dec 18 2020	81176	3761	239	388347764	18357952	1150994	32605	799	525	45.1	3.6	24	0	860	900	934	0	25755.1	24.7	33894
Dec 19 2020	81422	4007	246	389499800	19509988	1152036	32635	800	542	46.5	3.1	24	0	849	900	926	0	25755.1	23.6	33917.6
Dec 20 2020	81668	4253	246	390652070	20662258	1152270	32642	800	541	46.4	3.3	24	0	869	900	926	0	25755.1	24.7	33942.2
Dec 21 2020	81905	4490	237	391804604	21814792	1152534	32649	800	520	44.6	3.7	24	0	872	900	925	0	25755.1	24.6	33966.8
Dec 22 2020	82150	4735	245	392956364	22966552	1151760	32627	800	540	46.3	3.2	24	0	872	900	922	0	25755.1	24.7	33991.5
Dec 23 2020	82384	4969	234	394108380	24118568	1152016	32634	800	514	44.1	3.9	24	0	859	900	936	0	25755.1	23.6	34015.1
Dec 24 2020	82665	5250	281	395260390	25270578	1152010	32634	800	617	52.9	4.4	24	0	882	900	916	0	25755.1	24.7	34039.7
Dec 25 2020	82905	5490	240	396413282	26423470	1152892	32659	801	528	45.2	3.5	24	0	886	900	917	0	25755.1	24.6	34064.3
Dec 26 2020	83144	5729	239	397562421	27572609	1149139	32553	800	525	45.1	3.5	23.1	1	890	900	914	0	25755.1	24.1	34088.4
Dec 27 2020	83381	5966	237	398711960	28722148	1149539	32564	799	520	44.7	3.7	24	1	878	900	924	0	25755.1	24.4	34112.8
Dec 28 2020	83616	6201	235	399862984	29873172	1151024	32606	799	516	44.3	3.7	24	0	880	900	924	0	25755.1	24.6	34137.3
Dec 29 2020	83856	6441	240	401014971	31025159	1151987	32633	800	528	45.3	3.6	24	0	884	900	914	0	25755.1	24.6	34161.9
Dec 30 2020	84091	6676	235	402168158	32178346	1153187	32667	801	518	44.4	3.8	24	0	876	900	927	0	25755.1	24.7	34186.6
Dec 31 2020	84324	6909	233	403318727	33328915	1150569	32593	799	512	44	3.9	24	0	883	900	919	0	25755.1	23.6	34210.2