



2023

**PRIVATE
ACCESS
MANUAL**

**Revised 2023-06-15 by:
Public Works - Engineering Division**

PRIVATE ACCESS KEY POINTS

- It is the responsibility of the property owner benefitted by the private access and the contractor constructing, removing, relocating or modifying the private access to ensure that construction, removal, relocation or modification complies with;
 - a) Private Access By-Law No. 49/2008,
 - b) The permit issued for the work, including any conditions attached to the permit,
 - c) The Standard Construction Specifications,
 - d) The Manual of Temporary Traffic Control, and
 - e) Schedule “C” of the Private Access By-Law No. 49/2008
- The City of Winnipeg will not establish property lines or determine the location of the private access.
- The City of Winnipeg is not responsible to notify utilities for clearances.
- Where construction of the private access has been completed without an inspection having been arranged, the permit holder(s) must, at no cost to The City of Winnipeg, either demonstrate, at their own expenses, to the satisfaction of a designated employee that the private access meets all the requirements of The City of Winnipeg Private Access By-law No. 49/2008 or must re-construct the private access at their own expense
- Full depth saw cuts are required for the removal of existing curb and gutter, partial depth saw cuts are not allowed. When saw cutting into the existing street, **it must be full depth saw cutting and must be 0.3m from the back of the curb**. Cutting to the face of curb only will not be allowed. The finishing material of the curb & gutter replacement must match the finishing material of the street (see *Figure 24, page 53*)
- Unpaid permit(s) and/or no inspection will result in any damage deposit(s) not being released until it is proven that the approach meets all the requirements of The City of Winnipeg Private Access By-law No. 49/2008. This may result in the contractor’s license being put under review and/or penalties being assessed.
- If a manhole is present, please call the Area Approach Inspector prior to excavating for the approach (see ‘INSPECTOR CONTACTS’ **page 66**).

PRIVATE ACCESS KEY POINTS (Cont.)

- **Flag person**
 - Please be advised that the Province of Manitoba has amended the Workplace Safety and Health Regulation, Manitoba Regulation 217/2006 with the Regulation 165/2012, regarding Flag person rules, materials, equipment and signage. This information is available at <http://gov.mb.ca>, search Regulation 165/2012.
 - Flag person training can be provided through the Construction Safety Association of Manitoba at 204.775.3171 and the Manitoba Heavy Construction Association at 204.947.1379.
 - The City of Winnipeg **DOES NOT** provide Flag person training.
- Concrete in approaches must be supplied by Concrete Suppliers approved by The City of Winnipeg (Refer to '**LINKS**', **page 67** for Approved Concrete Suppliers Link)
- It shall be the Licensed Contractor's responsibility to ensure that the approach flares **DO NOT** extend beyond the projection of the property line(s). The property lines are to be established by a surveyor and clearly marked. Any proposed deviation from this must be approved through email by the City Junior Technologist. Any work completed without prior approval, will require reconstruction at the contractor's own expense.
- Licensed Contractor is responsible to obtain a **copy of the private access permit** prior to construction of the approach.
- Only **LICENSED CONTRACTORS** may construct, remove, modify or relocate a private access.
- Residential Approval/Permit requires a single application. Commercial Private Accesses will require an application for approval and a permit individually. Permits and approvals expire after **24 months**.
- The maximum conforming width for a **Residential** Private Approach is **6.5 meters** at property line.
- When constructing Private Accesses that are less than 1.5 meters from obstructions including but not limited to; fire hydrants, hydro poles, and communication pedestals, it is the applicants responsibility to have these relocated and applicants must discuss options with an inspector (see '**Other Rules**'; page 7; **Figure 28, page 57**)

PRIVATE ACCESS KEY POINTS (Cont.)

- Approval from City Forester is required if private access is within 2 meters of the outside of a tree trunk. (see '**OTHER CONTACTS**', **page 66**)
- Commercial and Residential approach inspections require twenty-four (24) hours' notice via email to the Approach Inspector to arrange for an inspection. The City of Winnipeg will no longer accept phone calls for approach inspections but rather an email to the Residential/Commercial Approach Inspector will be required. Please see contact information update (see **page 66**)
- A cross fall of 2-4% will be required throughout the entire approach where proposed sidewalks will be constructed at the property line. This applies to newly installed or proposed sidewalks in New Developments.
- The use of caution tape or non-approved signs is an illegal violation of the City's Streets By-Law 1481/77 and Traffic By-Law 1573/77, and is subject to prescribed fines. As outlined in the Manual of Temporary Traffic Control available on the City of Winnipeg website at: [Manual of Temporary Traffic Control on City Streets - City of Winnipeg](#)
- **Revisions have been made to City of Winnipeg Standard Construction Specification CW 3110-R22 – Sub-grade, Sub-base and Base Course Construction (see pages 19-21).**
- **Revisions have been made to City of Winnipeg Standard Construction Specification CW 3310-R18 – Portland Cement Concrete Pavement Works (see pages 22 - 23 and 'LINKS')**
- For information on Approach Culverts, see '*Approach Culverts: Diameter, Length & Elevations & Materials*' and '*Installation of Culverts*' noted under 'Miscellaneous' (see **pages 17 and 64**).
- **Figure Drawings printed in this manual shall supersede the City of Winnipeg Standard Details (SD) and must be adhered to when constructing private accesses.**

DISCLAIMER

Information in this manual is intended to supplement the *Private Access By-law 49/2008* including all amending By-laws and the City of Winnipeg *Standard Construction Specifications*.

TABLE OF CONTENTS

DEFINITIONS	1
FREQUENTLY ASKED QUESTIONS	3
GENERAL/SPECIFIC RULES	5
Non-Conforming Private Accesses	5
Licence for Contractors	6
Other Rules	7
Protection of Trees	7
Use of Street Permit	8
APPROVALS	9
Non-Conforming Private Approaches	9
Development Permit & Variance	10
CONSTRUCTION MATERIALS	11
SURFACE MATERIAL RESTRICTIONS	12
Roadway Type	12
Construction Material	12
LAYER MATERIALS	13
SUBGRADE	13
SUB-BASE	13
BASE COURSE	14
DRIVING SURFACES	15
MISCELLANEOUS	17
TABLES	19
Base Course and Sub-base Materials (CW 3110)	19
TABLE CW 3110.1 – Gradation Requirements	20
TABLE CW 3330-R3.1 – Bedding Sand Grading Requirements	21
PORTLAND CEMENT CONCRETE (CW 3310)	22
Concrete Types	22
TABLE CW 3310.5 – Concrete Properties	23
ASPHALTIC CONCRETE	24
Combined Aggregate Gradation Limits (Ref. TABLE 1 CW3410-R5.1)	24
Physical Requirements (Ref. TABLE 2 CW3410-R5.2)	24
DENSITIES, BOULEVARD & APPROACH SETTLEMENT	25
.....	25
Standard Proctor Densities	25
.....	26
Boulevard and Approach Settlement	26
APPROACH DETAILS	27
Chart I – Residential / Farm	28
Chart II – Commercial / Industrial	29

Figure 1: Regional Streets with Barrier Curb	30
1.) Commercial & Residential (on Regional Streets) Concrete Approach	30
Figure 2: Regional Streets with Barrier Curb	31
2.) Commercial & Residential (on Regional Streets) Paving Stone Approach ..	31
Figure 3: Regional Streets with Barrier Curb	32
3.) Commercial & Residential (on Regional Streets) Asphalt Approach	32
Figure 4: Regional Streets with Lip Curb	33
1.) Commercial & Residential (on Regional Streets) Concrete Approach	33
Figure 5: Regional Streets with Lip Curb	34
2.) Commercial & Residential (on Regional Streets) Paving Stone Approach ..	34
Figure 6: Regional Streets with Lip Curb	35
3.) Commercial & Residential (on Regional Streets) Asphalt Approach	35
Figure 7: Regional Streets with Shoulders	36
1.) Commercial & Residential (on Regional Streets) Concrete Approach	36
Figure 8: Regional Streets with Shoulders	37
2.) Commercial & Residential (on Regional Streets) Paving Stone Approach ..	37
Figure 9: Regional Streets with Shoulders	38
3.) Commercial & Residential (on Regional Streets) Asphalt Approach	38
Figure 10: Regional Streets with Shoulders	39
4.) Commercial & Residential (on Regional Streets) Gravel Approach	39
Figure 11: Non-Regional Streets with Barrier Curb	40
1.) Residential Concrete Approach	40
Figure 12: Non-Regional Streets with Barrier Curb	41
2.) Residential Paving Stone Approach	41
Figure 13: Non-Regional Streets with Barrier Curb	42
3.) Residential Asphalt Approach	42
Figure 14: Non-Regional Streets with Lip Curb	43
1.) Residential Concrete Approach	43
Figure 15: Non-Regional Streets with Lip Curb	44
2.) Residential Paving Stone Approach	44
Figure 16: Non-Regional Streets with Lip Curb	45
3.) Residential Asphalt Approach	45
Figure 17: Non-Regional Streets with Shoulders	46
1.) Residential Concrete Approach	46
Figure 18: Non-Regional Streets with Shoulders	47
2.) Residential Paving Stone Approach	47
Figure 19: Non-Regional Streets with Shoulders	48
3.) Residential Asphalt Approach	48
Figure 20: Non-Regional Streets with Shoulders	49
4.) Residential Gravel Approach	49
Figure 21	50

Public and <i>Residential</i> Concrete Sidewalk Ramp Detail	50
Figure 22	51
Manhole Isolation Details for Concrete Approaches	51
Figure 23	52
Curb and Gutter Inlet Isolation Detail in Concrete/Asphalt Over Concrete Approaches	52
Figure 24	53
Curb and Gutter Replacement for Commercial and Residential Approaches; Concrete/Paving Stone or Asphalt Streets with Barrier or Lip Curbs > 80mm	53
Figure 25	54
<i>Residential</i> Approach Reinforcing Steel Saw Cut Layouts and Bar Mat Layout for Approaches	54
Figure 26	55
<i>Commercial</i> Approach Saw Cut Layouts.....	55
Figure 27	56
<i>Commercial</i> Approach Reinforcing Steel and Layout for Type 'A' and 'B' Bar Mat Reinforcement.....	56
Figure 28	57
Approaches Located Adjacent to Obstructions, Including but Not Limited to Fire Hydrants, Hydro Poles and Communication Pedestals	57
Figure 29	58
Modified Barrier Curb for <i>Commercial</i> Concrete Approaches.....	58
Figure 30	59
Curb Ramp Detail for <i>Commercial</i> Concrete Approaches	59
Figure 31	60
Curb Details for New Asphalt Pavements	60
GENERAL INFORMATION.....	61
Approvals / Permits.....	61
Inspections.....	62
Re-inspection Fee.....	62
Median Modifications, Loading Bays and Turning Lanes.....	62
Cold Weather Concreting (Clause 6.12.3 of Specification CW3310).....	63
Approach Culverts: Diameter, Length & Elevations & Materials.....	64
Manhole & Catch Basin Adjustment (Reference Spec No. CW 3210 & CW 2130).....	64
APPROACH INSPECTION BOUNDARIES.....	65
INSPECTOR CONTACTS	66
OTHER CONTACTS	66
LINKS	67
NOTES.....	68

DEFINITIONS

“Boulevard”	means the grass and/or earth portion within the Right-of-Way.
“Lane”	means a street not more than nine meters in width.
“Private Access Contractor”	means a contractor who holds a valid licence issued pursuant to By-law 49/2008.
“Non-residential Property”	means real property that is not residential property as defined in By-law 49/2008.
“Private Access”	means a private approach, private walk, loading bay, turning lane or median opening.
“Private Access Permit”	means a permit for the construction, modification, relocation or removal of a private access issued pursuant to By-law 49/2008."
“Private Approach”	means any modification to a street in order to facilitate vehicular access to private real property and includes a vehicular drive, road, path, culvert, lane widening or other structure constructed or maintained within a street between private real property and the roadway line for the use or benefit of the owner or occupant of the real property.
“Private Walk”	means the infrastructure installed from an adjacent roadway to private property in order to facilitate pedestrian access to the property; it includes the modification or removal of a curb, <u>if permitted</u> ; or the modification of the boulevard, including the installation of any surfacing material (asphalt or poured concrete) or substance that adjoins to the curb of the adjacent street.
“Property Line”	means the line between the street and adjacent private real property.

“Regional Street”

means a street listed in Schedule “E” of the Streets By-law No. 1481/77 or a street identified as a regional street in a successor by-law to the Streets By-law (Refer to **‘LINKS’** page 67).

“Street”

means any place part of which has been dedicated as a roadway, lane, footpath, walkway, according to The Real Property Act or which the public is ordinarily entitled to use for passage, with or without fee or charge therefore, and includes all the space within the City Right-of-Way.

“Driveway”

an extension of the approach on private property verses an approach which is in the City of Winnipeg Right-of-Way.

“Designated Employee”

means the Director of Public Works and any person to whom the Director has delegated authority to enforce or administer all or part of the Private Access By-Law and Private Access Manual.

“Standard Construction Specifications”

means the Standard Construction Specifications for infrastructure work on City Streets approved by the Public Works Department and, unless otherwise specified, refers to the most recent edition at; (Refer to **‘LINKS’** page 67)

“Conforming”

when referring to a proposed or constructed private access, means a private access that conforms to the rules set out in sections 18 to 21 of the Private Access By-Law (Refer to **‘LINKS’** page 67)

“Non-conforming”

when referring to a proposed or actual private access, means a private access that fails to conform to the rules set out in sections 18 to 21 of the Private Access By-Law (Refer to **‘LINKS’** page 67)

FREQUENTLY ASKED QUESTIONS

Is a Permit required to construct a private approach or private walk, or to modify an existing approach or walk?

Yes. In most cases an approval/permit is required. Every owner desiring an approach or private walk or any relocation or widening thereof must make a written application.

Applications for Residential private approaches on Non-Regional Streets must be made at the **Customer Service Branch of the Public Work's Customer Services counter, 107-1155 Pacific Ave** or through the following link: [Residential Private Approach - Public Works - City of Winnipeg](#). You may also contact the Plan Approval/ Permit Technologist at **204.986.4113** or pwdpermits@winnipeg.ca for inquiries.

Applications for all Commercial private approaches and Residential private approaches on Regional Streets must be made at the following link: [Commercial Approach - Public Works - City of Winnipeg](#) and the form can be returned to PWDPrivateAccess@winnipeg.ca.

The application will be reviewed to determine if it conforms with the Private Access By-law No. 49/2008.

For more information on Approvals/Permits see 'GENERAL INFORMATION', page 61.

Approach Approval/Permit lapses 24 months after issue date.

What information do I require to make an application?

You should provide a copy of a **Surveyor's Building Location Certificate** showing the location and dimensions of the proposed approach. As an alternative, a well-drawn site plan showing all property dimensions, locations of buildings and the location and

dimensions of the proposed approach may be acceptable.

How can I obtain a Buildings Location Certificate?

Most home-owners already have this document - it usually comes with the purchase of a house. A qualified Land Surveyor: <https://amls.ca/wp-content/uploads/2023/01/Survey-firms-2023.pdf> can provide the certificate.

What if my application does not conform to the Private Access By-law?

If the approach does not conform to the By-law you will be advised as to why the application is non-conforming and informed of the process to follow should you wish to make an appeal to the applicable Community Committee for a residential approach or to the Standing Policy Committee for a commercial approach.

Who may construct a private access?

No person other than a licensed contractor, the employees of a licensed contractor or a City employee acting in the course of his or her employment may construct, remove, modify or relocate a private access.

I have an existing approach that is no longer required am I responsible for the cost of removing it?

Yes, the owner is responsible for the cost of removal of an existing private approach or part thereof. Only where it is considered by the City to be in the public interest to remove an approach that is no longer required will the cost of removing the approach be paid by the City.

A list of licensed Private Approach Contractors is available from:

Online at:

www.winnipeg.ca/publicworks/permitsApprovals/approaches/default.stm

or email [pwdPA-](mailto:pwdPA-DDInspector@winnipeg.ca)

DDInspector@winnipeg.ca

Are there City Standards that must be followed when constructing a private approach/walk?

Yes. One of the primary purposes of this book is to provide you with the minimum standards that must be met. These minimum standards in no way prevent you from constructing an approach that exceeds these standards. In fact, in certain circumstances it is recommended that the approach design be increased.

There is a manhole in the boulevard in the location where I wish to construct my private approach. How will this affect my approach?

The property owner is financially responsible for any adjustments of manhole/catch basin (see 'Manhole & Catch Basin Adjustment (Reference Spec No. CW 3210 & CW 2130)' for details). If the approach is to be concrete it will be necessary for you to construct an isolation (see **Figure 22&Figure 23**).

Any valve box or curb stop adjustments can only be done by a **City Licensed Sewer/Water Contractor**. (see '**LINKS**'; **Page 67**)

Be sure to read the section on 'DENSITIES, BOULEVARD & APPROACH SETTLEMENT' on **Page 25 & 26.**

Who is responsible for repairing a Private Approach?

The **owner of the approach** is responsible for the cost of reconstruction, reinstallation, repair, alteration or maintenance. Should a private approach deteriorate to an unsafe condition the City can give written notice to the owner ordering the repairs to be done at the owner's cost.

The street pavement is being renewed will I be required to pay for any necessary alterations to my private approach?

No. The City shall assume the costs, whenever the City widens, reconstructs or resurfaces a pavement and thereby necessitates alteration or reconstruction of a lawful private approach or walk. If the approach is not constructed to the same standard as the abutting street, the City may assess the cost of improving the approach against the benefiting property.

The City's Waterworks crews removed a part of my approach while carrying out a repair to the Watermain will they be repairing the approach?

Yes. When the City, a utility company or others do work in a street that damages a lawful private approach or walk the person responsible for the damage shall assume the entire cost of restoring the approach or walk to its original condition. In most cases the utility will obtain a permit to make the excavation and will pay to the City the fees required to do the restoration.

My approach that was inspected by the City of Winnipeg has cracked. Is the City liable?

The City inspects the approach for design, layout and dimensions. The City was not a part of any agreements made between the owner and contractor or owner and supplier. **It is the owner's responsibility to ensure that minimum standards for both materials and construction practices are met. These standards are discussed later in this booklet.**

GENERAL/SPECIFIC RULES

Non-Conforming Private Accesses

General Rules re. Private Access

17(1) deleted 81/2021

17(2) deleted 81/2021

Specific Rules re. Residential Approaches ¹

18. Private approaches benefiting residential properties are non-conforming if they fail to conform to the following rules:

(a) an approach must not be less than 3 metres or greater than 6.5 metres wide measured along the property line;

(a.1) the private access must not be detrimental to the safe and efficient movement of vehicular and pedestrian traffic upon the adjacent street; added 81/2021

(b) subject to subsection 25(3), a private approach must not extend beyond the lot line² of the adjacent property projected into the street if

(i) the approach could negatively impact an existing or future conforming private approach benefiting an adjacent property; and

(ii) an alternate location of the approach is possible, taking into account the proposed or actual location of buildings on the lot;

(c) an approach must not be constructed or allowed to exist where a lane at least 4.5 metres wide is adjacent to the property, whether or not the lane is improved.

Notes: 25(3) Notwithstanding clause 18(b) and subject to subsection (4), in order to accommodate an approach benefitting adjacent property, the Director may authorize the removal or modification of that portion of a private approach that has been permitted to extend beyond the lot line of the adjacent property projected onto the street.

¹ The City of Winnipeg Private Access By-Law 49/2008 & 81/2021:

<https://clkapps.winnipeg.ca/DMIS/docext/ViewDoc.asp?DocumentTypeId=1&DocId=4136>
<https://clkapps.winnipeg.ca/DMIS/docext/ViewDoc.asp?DocumentTypeId=1&DocId=7995>

² A Property Map can be viewed at the following link:

https://legacy.winnipeg.ca/ppd/maps_aerial.stm

25(4) The cost of the removal or modification referred to in subsection (3) must be borne by the owner of the property being benefitted by the approach being constructed.

25(5) Notwithstanding that a private access has been approved by the City and is otherwise in compliance with this By-law, where Transport Canada or a railway company requires the removal, modification or relocation of the private access as a condition of maintaining a railway crossing, it must be removed, modified or relocated at the expense of the owner of the benefitting property.

An application that does not meet one or more of the General/Specific Rules must be rejected by the officer for the City.

Licence for Contractors

Criteria for issuing contractors licenses

26(1) Subject to subsection (2), the Director shall issue an annual contractor's licence to a person who

- (a)** pays a fee for a licence in an amount established by Council from time to time;
- (b)** provides, in form and substance satisfactory to the Director, a policy of commercial general liability insurance in the amount determined by the Director and on terms satisfactory to the Director;
- (c)** provides security in an amount established by the Director and in a form satisfactory to the Director;
- (d)** has demonstrated the knowledge and ability to meet the requirements of this By-law and other applicable by-laws, the Standard Construction Specifications and the Manual of Temporary Traffic Control.

If a Licenced Private Access contractor fails to meet the requirements of Section 26(d) of the Private Access By-Law¹, the Director or designated City employee can act under Section 28(1) of the By-law to suspend the contractor's license or to take another action referred to in that subsection.

Other Rules

Where manholes exist, manhole isolation must be included in the construction of the approach. (See **Figure 22& Figure 23**)

An approach shall be constructed such that the minimum of one and a half (1.50) meters of clearance is maintained from all obstructions. Obstructions include but not limited to; lamp standards, hydro poles, fire hydrants and communication pedestals. (See **Figure 28**) The cost of removal or relocation or replacement of these obstructions shall be borne by the property owner. Any relocation of a fire hydrant requires approval from the Water and Waste Department and the applicant should email WWD-Permits@winnipeg.ca to inquire. The applicant will also be responsible to contact Underground Structures and plans should be submitted to ugsapproval@winnipeg.ca.

The Private Access By-law contains a number of Schedules that restrict the construction of approaches on:

Most main Arterial Streets that do not have service roads; and streets where there is other means of access to the property. (Schedule 'A' & 'B' of the Private Access By-Law)¹

Protection of Trees

The Contractor shall take precautionary steps as specified to prevent damage from construction activities to existing boulevard trees within the limits of the construction area. All damage to existing trees caused by the Contractor's activities shall be repaired to the requirements of the City Forester or the designate.

- All approaches must maintain at least two (2.0) meters clearance from the outer edge of the trunk of a tree unless approval is granted by the City Forester (**See 'OTHER CONTACTS', page 66**)
- The contractor shall not stockpile materials and soil or park vehicles and equipment on boulevards within two (2) meters of trees.
- Trees identified to be at risk by the Contract Administrator are to be strapped with 25 x 100 x 2400mm wood planks, or suitably protected as approved by the Contract Administrator.

- Any pruning of tree roots or branches, and/or tree removal³ work must be performed by a Qualified Arborist, which can be found on the Urban Forestry Branch's website under 'Guidelines for maintaining City owned trees using a qualified contractor'.

Use of Street Permit

All activities that impede or temporarily occupy the Street (commonly referred to as the right-of-way) require a Use of Street permit. There are different types of Use of Street permits depending on the activity, described at the following link: [Permits - Public Works - City of Winnipeg](#)

The Traffic Management Branch must be contacted for permission to work on a [Regional Street](#) in accordance with Section 2.00 of the [Manual of Temporary Traffic Control](#) in addition to obtaining a Use of Street permit. Request a [Street/sidewalk closure](#).

To enquire about obtaining a Use of Street permit please email PWD-UOS-Permits@winnipeg.ca or phone 204-986-6006.

³ Urban Forestry: [Maintaining City-owned trees - Urban Forestry - Parks and Open Space - Public Works - City of Winnipeg](#)

APPROVALS

An application for a private approach or private walk which meets all of the Rules shall be approved and an Approval/Permit issued for construction and installation, unless the City is of the opinion that the approval of such approach or walk would be detrimental to the public interest. Example: Property owner of a corner lot wishes to construct a private approach on the side of the lot which is adjacent to a collector/bus route.

Non-Conforming Private Approaches

The Private Access By-law provides the property owner with a method of appealing an application that is refused;

- a) because it does not conform with one or more of the Rules,
- or;
- b) on the basis that it is detrimental to the public interest.

Upon application for a private approach or private walk that does not comply with the Rules, or is determined to be detrimental to the public interest, the City will notify the applicant why the application has been denied and outline the procedure that the applicant can follow should the applicant wish to appeal to the designated Committee.

Where an application has been denied on the basis that it does not conform with one or more of the Rules of the By-law, the onus shall be on the owner to satisfy the Committee that:

- i. no feasible method of providing access is possible within the terms of Rules;
- ii. the approach is necessary for the intended use of the property, and;
- iii. the granting of a variation of the terms of Rules will not be detrimental to the public interest.

Where an application has been denied on the basis that it is detrimental to the public interest the onus shall be on the City to satisfy the Committee of such detriment.

Applicants are welcome to attend Community Committee meetings, for information regarding the process, call the Plan Approval/Permit Technologist; 204.986.4113 or PWDpermits@winnipeg.ca .

Development Permit & Variance

According to the Zoning by-law 200/2006, parking to the front is permitted provided it leads to a parking space (e.g. garage or side/rear yard).

An application must be submitted to PP&D and Zoning for a Development permit and Variance to allow any widening in front of a home that does not lead to a garage or side/rear yard. The approval of the approach will be based on: an official approval from Zoning and PP&D for the driveway portion; obtain a proper approach permit and receive approval during a pre-pour inspection from the Approach Inspector.

Any changes to the geometry or surface material of the driveway also requires a development permit and an application must be submitted to the Zoning and Permits Branch before obtaining an approach permit. All applications must go through ppd-zoningapplications@winnipeg.ca or call **204-986-5140**.

CONSTRUCTION MATERIALS

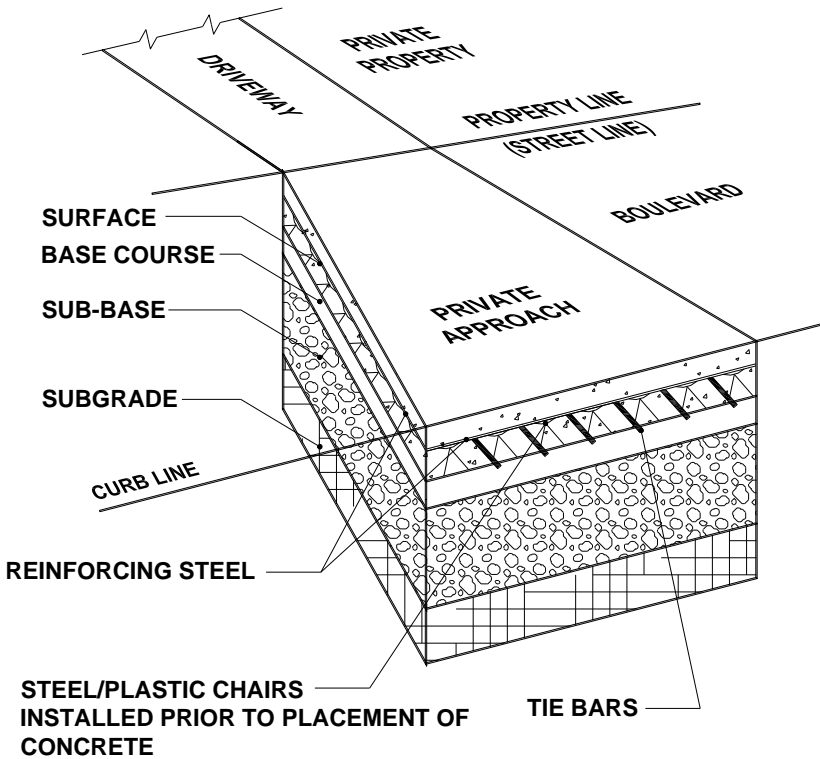

Material Layers

SURFACE MATERIAL RESTRICTIONS

Roadway Type	Construction Material
Concrete Roadway (with or without asphalt overlay)	
• with curb	Concrete*
• with asphalt or concrete shoulders:	Concrete*
• with gravel shoulders -farm or single family/duplex residential	Gravel, asphalt or concrete*
-all other land uses	Concrete*
Asphalt Roadway	
• with curb	Asphalt or concrete*
• with asphalt or concrete shoulders:	Asphalt or concrete*
• with gravel shoulders -farm or single family/duplex residential	Gravel, asphalt or concrete*
-all other land uses	Asphalt or concrete*
Gravel Roadway**	Gravel
* - includes a surface constructed of paving stones or concrete underlay with asphalt overlay.	
** - includes a surface constructed of oil treated <u>gravel or chip sealant</u> roadways.	

LAYER MATERIALS

THE FOLLOWING ARE **MINIMUM STANDARDS** DERIVED FROM THE CITY OF WINNIPEG STANDARD CONSTRUCTION SPECIFICATIONS⁴.
IT IS THE RESPONSIBILITY OF THE OWNER/APPLICANT/LICENSED CONTRACTOR TO ENSURE THAT THESE STANDARDS ARE MET OR EXCEEDED.

SEE THE FOLLOWING IMPORTANT INFORMATION ON:

- 1) PAGE 25 FOR IMPORTANT INFORMATION ON STANDARD PROCTOR DENSITIES AND**
- 2) PAGE 26 FOR IMPORTANT INFORMATION CONCERNING BOULEVARD & APPROACH SETTLEMENT**

SUBGRADE

ALL SURFACES (CW 3110)

Suitable site material	Compact to a min. 95% Standard Proctor Maximum Dry Density
Unsuitable material	Replace a min. depth of 300mm with sub-base material. See CW 3110 for acceptable sub-base materials (see also Crushed Sub-Base Material Grading Requirements (page 20) and compact to specified density.

SUB-BASE

ALL SURFACE TYPES (EXCEPT GRAVEL – Where Clay material is used)

(WHERE THERE IS UNSUITABLE SUBGRADE MATERIAL) (CW 3110)

Type	See CW 3110 for acceptable materials See also Crushed Sub-Base Material Grading Requirements (page 20)
Min. thickness	300mm (Placed in compacted layers not exceeding 150mm)
Max. aggregate size	50mm
Gradation	As specified in CW 3110 see also Crushed Sub-Base Material Grading Requirements (page 20)
Compaction	As specified in section 3.3.8 of CW 3110 – R22

⁴ The City of Winnipeg Standard Construction Specifications are available in Adobe Acrobat (PDF) format at The City of Winnipeg, Corporate Finance, Materials Management internet site www.winnipeg.ca/matmgt/Spec/Default.stm

FOR INTERLOCKING PAVING STONE (CW 3330)

FOR COMMERCIAL APPROACHES (CW 3335)

Type Lean Concrete Mix over Sub-base

Lean Mix Concrete

Min. Thickness	150mm
Aggregated size	20mm nominal
Slump	25-75mm
Compressive Strength	5-10 MPa @ 28 DAYS
Air content	5-8%
Cement content	150 kg/cu.m.
Fly ash (10% of cement)	15 kg/ cu.m.

FOR COMMERCIAL & RESIDENTIAL APPROACHES (CW 3330)

Type	Granular A or B
Min. thickness	300 mm (placed in two 150mm layers)
Max. aggregate size	50mm
Gradation	well graded
Compaction	100% Standard Proctor Density

BASE COURSE

FOR CONCRETE (CW 3110)

Types	See CW 3110 for acceptable base course materials (see also Base Course Material Grading Requirements (page 20) (Commercial – Granular A or B, Residential – Granular A, B, or C) ⁵)
Compaction	100 % Standard Proctor Maximum Dry Density
Min. thickness	75mm

FOR PAVING STONES (CW 3330 & 3335)

Types	Bedding Sand, conforms to CSA-A23.1 Section 2.2.1 for fine aggregate, see CW 3310. Filler Sand (max. aggregate size of 2.5mm)
Min. thickness	See also Bedding Sand Grading Requirements (page 21) 30mm of Bedding Sand <u>without</u> lean mix concrete base (CW 3330) 15mm of Bedding Sand <u>with</u> lean mix concrete base (CW 3335)

FOR ASPHALT (CW 3410)

Types	See CW 3110 & CW 3410 for acceptable base coarse materials (See also Base Coarse Material Grading Requirements, page 20). (Commercial – Granular A or B, Residential – Granular A, B, or C) ⁵)
-------	---

⁵ Refer to Base Coarse Material Grading Requirements (page 20) for more information

Compaction	100% Standard Proctor Density
Min. Thickness	200mm <i>Residential</i> (placed in two 100mm layers)
	300mm <i>Commercial</i> (100mm Base Coarse + 200mm Sub-base – 50mm nominal)

DRIVING SURFACES

CONCRETE (CW 3310 – R18)

Concrete Properties and Definitions noted on pages 22-23

Note: All concrete placed must be supplied by an Approved Concrete Supplier. A list of these suppliers is made available on the City of Winnipeg Website @ https://legacy.winnipeg.ca/finance/findata/matmgt/std_const_spec/current/Docs/Approved_concrete_suppliers.pdf

HYDRAULIC CEMENT

As specified under *section 2.3 of CW3310*.

CONCRETE MIX DESIGN

FOR RESIDENTIAL APPROACHES

Type	Type 2 or 1 (see pages 22-23)
Min. Thickness	150mm
Min. Compressive Strength	32 MPa @ 28 DAYS

FOR COMMERCIAL APPROACHES

Type	Type 1
Min. Thickness	200mm
Min. Compressive Strength	35 MPa @ 28 DAYS

COLD WEATHER CONCRETE (Replaces all types when Cold Weather exists)

Min. Compressive Strength	35 MPa @ 28 DAYS
	24 MPa @ 3 DAYS
	20 MPa @ 1 DAY

REINFORCING STEEL (Figure 25 & Figure 27)

Type A	12.7mm plain bars, grade 300, conforms to CSA G30.12.
Type B	10M (Deformed), grade 300, conforms to CSA G30.12.
Placement	Maintain a 75mm clearance from edges. Elevate to mid depth of the concrete using steel/plastic chairs sufficiently placed to ensure positioning is maintained during concrete placement.

RESIDENTIAL APPROACH REINFORCING STEEL (SD-237 & Figure 25)

Alternative 1	Place in a grid to form a mat. Spaced not greater than 470mm O.C. in both directions, and welded or securely fastened at intersections. (Figure 27)
Alternative 2	Cut and place to form a grid spaced not greater than 400mm O.C. in both directions and welded or securely fastened at intersections.

COMMERCIAL APPROACH REINFORCING STEEL (SD-217 & SD-211A) (Figure 26 & Figure 27)

Bar Mats are to be used in accordance with SD-217 **(Figure 26 & Figure 27)** and ALTERNATIVE 1, SECTION A-A of SD-237 **(Figure 25)**

PAVING STONES (CW 3330)

Type	Conforms with CAN3-A231.2 Pre-cast Concrete Pavers
Placement	Paving Stones shall be compacted into the bedding sand layer using approved vibratory compactors until they are at the proper grade, uniformly level and free of any movement. Filler sand shall be swept into the joints until full.

ASPHALTIC CONCRETE (CW 3410)

See:

Combined Aggregate Gradation Limits **(pg.24)**
Physical Requirements **(pg. 24)**

FOR RESIDENTIAL APPROACHES

Type IA, or Type I Min. thickness 75mm

FOR COMMERCIAL APPROACHES

Type IA Min. thickness 75mm

OVERLAY FOR CONCRETE

Type II Min. thickness 20mm

GRAVEL (CW 3150)

Base Coarse Material	See Base Coarse Material grading requirements Granular B or C (pg. 20)
----------------------	---

MISCELLANEOUS

CONCRETE INCIDENTAL ITEMS(CW 3110)

Isolation Joint	Plastic expansion joint filler, fluted polypropylene type 6mm in thickness.
Expansion Joint ⁶ (For Sidewalk)	Sidewalk expansion joints shall be a closed-cell expansion joint filler.
Contraction Joint	Saw-cut 3mm wide x one-third (1/3) depth of pavement as per Section 6.7.6. of CW3310 and located as shown on Figure 25& Figure 26, SD-211A & SD-211B⁴
Tie Bars ⁶ (Grade 300)	(Approach to pavement) – 15M (Res.) / 20M (Com.) deformed epoxy coated bars, 600mm long, placed 600mm O.C., drilled into existing pavement 230mm and bonded as shown in SD-213B⁴ (Curb Ramps for sidewalk in Res. & Com. approaches) – 15M deformed epoxy-coated bars, 600mm long, placed 600mm O.C. as per SD-229C, SD-229B⁴ & Figure 21, Figure 30
Dowels ⁶ (Grade 300)	(Installed at contraction or transverse joints) 450mm long – 19.1mm, 450 O.C. (Res.) / 28.6, 300 O.C. (Com.), drilled into existing pavement 160mm and bonded as shown in SD-213B.
Dowel Adhesive ⁶	Conforms to ASTM C881M, Type 1, Grade 3 epoxy shall be used for bonding tie bars and dowels into hardened concrete. Installed as per Section 6.3.2.2.2 of CW3110.
Curing Compound ⁶	Conforms to ASTM C309, Type 2, Class B white-pigmented, and water based liquid membrane-forming curing compound.

CAST IN PLACE CONCRETE CURBS FOR ASPHALT/PAVING STONE APPROACHES (CW 3310)

Size	100mm Wide X 200mm Deep
Hydraulic Cement Type (depends on Street Classification)	As specified under <i>section 2.3 of CW3310</i> . Type 1 or 2 (See pages 22-23)
Reinforcing Steel	Conforms to CSA G30-12 Billet Steel for reinforcement, 2-15M deformed bars spaced as shown on SD-238A/B & SD-237A/B.⁴

⁶ Refer to “Approved Products for Surface Works” in Standard Construction Specifications: https://legacy.winnipeg.ca/finance/findata/matmgt/std_const_spec/current/Docs/Approved_Product_Suppliers.pdf

PLASTIC PAVER EDGE SUPPORT FOR PAVING STONE APPROACHES (CW 3330)

Plastic paver edge support shall be made of High Density Polyethylene (HDPE) material.

Plastic paver edge support may be installed as a paving stone edging for residential approaches. All installation shall be in accordance with the manufacturer's instructions.

For vehicular applications 10" or 12" x 3/8" diameter steel spikes shall be spaced every 12" (min. every 3rd hole) with the exception of radius applications, where the steel spikes should be spaced every 8" to 12".

An acceptable plastic edge support is "Snap Edge" as manufactured by Snapedge Canada Ltd. or Snap Edge Corporation.

www.snapedge.ca

CULVERTS FOR STREETS WITH DITCH TYPE DRAINAGE (CW 3610)

Diameter Size To be determined by the **City of Winnipeg, Water & Waste Department, Engineering Division, Land Drainage and Flood Protection Technologist** at 204.986.3670. or email CNault@winnipeg.ca

Length **Contractor** to calculate culvert length based on approved approach width, shoulder widths and a minimum 4:1 (rise over run) ditch slope.

Type⁶ **Corrugated Steel Pipe**, conforms to CSA CAN/CSA-G401 **Pre-cast concrete pipe**, conforms to ASTM C-14, C-76, or C-655, **High Density Polyethylene (HDPE) Pipe**, conforms to CSA B182.8 and ASTM D2412.

Culvert End⁶ Markers

Supply culvert end markers in accordance with the following:

- 1.) Culvert end markers shall be 1500 ± 100mm in height.
- 2.) Culvert end markers shall be HDPE, SDR 9.3, 30mm (1¼") in diameter, bright orange in color with an adhesive backed reflective strip placed around the marker. The reflective strip shall be placed within 25mm of the top of the marker.

INSTALLATION OF CULVERTS (CW 3610)

All construction methods under **section 3.1 of CW3610** for Excavation, Bedding and Backfill are to be followed and proper materials under **section 2 of CW3610** are to be used. The Standard Construction Specifications for the Installation of Culverts (CW 3610) can be found online. (see **'LINKS', page 67**)

TABLES

Base Course and Sub-base Materials (CW 3110)

Granular A – open-graded virgin (not recycled) aggregates intended for use as free draining base and sub-base within the pavement structure. Granular A is intended for high traffic volume streets, including expressways, major arterials, minor arterials, industrial/commercial collectors, residential major collectors, residential minor collectors, industrial/commercial locals and associated approaches.

Granular B – well-graded virgin or recycled aggregates intended for use as base and sub-base within the pavement structure. Granular B is intended for low traffic volume streets including residential local, public lanes, asphalt pathways and associated approaches. Granular A can be used instead of Granular B.

Granular C – dense graded virgin or recycled aggregates intended for use as base and sub-base. Granular C is intended for rehabilitations and other applications. Granular A or B can be used instead of Granular C.

Crushed Recycled Concrete – aggregates obtained by recycling clean, hard, concrete waste with maximum lightweight material/asphalt content of 8%, maximum clay content of 3% and maximum other foreign or deleterious materials content of 3%. All types of contaminants, such as dirt, plaster, gypsum and other building waste, must be removed.

Deleterious Material – soft material that would decay or disintegrate from weathering, porcelain, vegetation, organic material, wood, glass, plastic, metal, reinforcing steel, building rubble, brick, shale, and friable particles.

Oversize Material – The percent fraction by weight of the aggregate retained on the 19.0 mm sieve.

Base Course and sub-base materials shall conform to the following requirements:

- a) Base course and sub-base materials will be of a type approved by the Contract Administrator.
- b) Base course and sub-base materials shall be sound, durable particles produced by crushing, screening, and grading of recovered materials.
- c) Base course and sub-base materials shall conform to the grading requirements in Table CW 3110.1 and the physical requirements in Table CW 3110.2

Note: All aggregate material placed must be supplied by an Approved Aggregate Supplier. Effective July 1st, 2020, the City of Winnipeg, Research and Standards Engineer will maintain a list of approved aggregate suppliers. A list of these suppliers is made available on the City of Winnipeg Website @ www.winnipeg.ca/matmgt/Spec/Default.stm.

TABLE CW 3110.1 – Gradation Requirements

Canadian Metric Sieve Size	Percent of Total Dry Weight Passing Each Sieve											
	Granular A*			Granular B**			Granular C**					
	Base Course	50 mm	100 mm	Base Course	50 mm	100 mm	Base Course	50 mm	100 mm	Base Course	50 mm	100 mm
125 000			100%			100%						100%
100 000			85% - 100%			85% - 100%						90% - 100%
75 000		100%	70% - 92%		100%	--					100%	--
50 000		97% - 100%	50% - 78%		97% - 100%	50% - 80%					97% - 100%	--
37 500		75% - 95%	--		75% - 95%	--					--	--
28 000	100%	--	--	100%	--	--					--	--
25 000	97% - 100%	55% - 87%	25% - 58%	97% - 100%	55% - 87%	28% - 60%			100%		--	30% - 60%
20 000	85% - 95%	--	--	85% - 95%	--	--			97% - 100%		--	--
10 000	47% - 70%	25% - 60%	15% - 40%	45% - 75%	28% - 65%	18% - 45%			--		--	--
5 000	32% - 55%	16% - 48%	--	--	--	--			28% - 65%		20% - 60%	--
2 500	18% - 45%	--	--	20% - 48%	--	--			22% - 60%		--	--
1 250	11% - 35%	8% - 30%	5% - 20%	--	10% - 35%	5% - 25%			--		--	--
630	8% - 26%	--	--	8% - 28%	--	--			--		--	--
315	5% - 18%	4% - 18%	3% - 14%	5% - 20%	4% - 22%	4% - 15%			3% - 22%		--	--
80	2% - 8%	2% - 8%	2% - 8%	2% - 8%	2% - 8%	2% - 8%			2% - 10%		3% - 12%	0% - 8%

TABLE CW 3330-R3.1 – Bedding Sand Grading Requirements

BEDDING SAND	
<p>Bedding sand shall be fine aggregate as specified in Section 2.2.1, Table CW3310.2 of Specification CW 3310, that the sand shall conform to the following grading requirements:</p>	
<u>CDN. METRIC SIEVE SIZE</u>	<u>PERCENT OF TOTAL DRY WEIGHT PASSING EACH SIEVE</u>
10 000	100%
5 000	95% - 100%
2 500	80% - 100%
1 250	50% - 85%
630	25% - 60%
315	10% - 35%
160	5% - 15%
80	0% - 10%

PORTLAND CEMENT CONCRETE (CW 3310)

Concrete Types

Type 1 Concrete shall be used for expressways, major arterials, minor arterials, industrial/commercial collectors, residential major collectors, residential minor collectors, and industrial/commercial local pavements, commercial approaches. Curbs shall match the concrete type based on the street classification⁷.

Type 2 Concrete shall be used for residential streets and alleys, residential approaches, miscellaneous concrete slab and splash strips. Type 1 Concrete can be used instead of Type 2 Concrete. Curbs shall match the concrete type based on the street classification⁷.

Type 3 is early opening concrete and shall be used for 24 hours early opening after placement.

Type 4 is early opening concrete and shall be used for 72 hours early opening after placement.

Type 5 Concrete shall be used for Sidewalks. Type 1 or Type 2 Concrete can be used instead of Type 5 Concrete.

Type 6 is concrete for restoration of utility pavement cuts.

Type 7 is concrete for temporary restoration.

Cold Weather Concrete is concrete for Cold Weather and shall replace all other concrete types for all applications when Cold Weather exists, except Type 7.

Cold Weather is defined as a period when the nearest official meteorological office predicts the ambient air temperature will be below 5 °C within 24 hours of placing concrete.

***Note** – Type 6 and 7 is not applicable to approaches.

Note: All concrete placed must be supplied by an Approved Concrete Supplier. A list of these suppliers is made available on the City of Winnipeg Website @ [Approved concrete suppliers.pdf \(winnipeg.ca\)](#)

⁷ **Street classification** can be found at the following link: <https://legacy.winnipeg.ca/publicworks/snow/street-priority.stm>

P1 – expressways, major arterials, minor arterials (Type 1)

P2 – industrial/commercial collectors, residential major collectors, residential minor collectors, and industrial/commercial local pavements (Type 1)

P3 – residential streets and alleys (Type 1 or 2)

TABLE CW 3310.5 – Concrete Properties

	Type 1	Type 2	Type 3	Type 4	Type 5	Type 6	Type 7	Cold Weather Concrete
Maximum Cementitious Content (kg/m ³)	360	340	360	360	320	340	300	400
Maximum Supplementary Cementing Materials – Fly Ash **	20%	20%	20%	20%	20%	20%	20%	10%
Maximum Water/Cementitious Ratio								
- Slip form paving	0.4	0.4	0.4	0.4	-	-	-	0.35
- Hand placement	0.42	0.42	0.42	0.42	0.42	0.42	0.45	0.36
Slump (mm)								
- Slip form paving	50 ± 20	50 ± 20	50 ± 20	50 ± 20	-	-	-	50 ± 20
- Hand placement	70 ± 20	70 ± 20	70 ± 20	70 ± 20	80 ± 20	100 ± 20	100 ± 20	70 ± 20
Nominal Maximum Aggregate Size (mm)	20	20	20	20	20	20	20	20
Air Content (%)	5-8	5-8	5-8	5-8	5-8	5-8	5-8	5-8
Minimum Compressive Strength (MPa)								
- @ 1 days	15	15	20	-	-	Note*	-	20
- @ 3 days	35	35	Note*	Note*	30	-	-	24
- @ 28 days	-	-	-	-	-	-	30	35
Maximum Rapid Chloride Penetrability Test*** (coulombs) @ 91 days.	1500	1750	Note*	Note*	-	-	-	1500

*The concrete shall meet Type 1 or Type 2 based on the application.

**The use of fly ash in concrete mix will be permitted as a partial replacement of cement for Period I and will be permitted as additional to the cement for Period II unless authorized in writing by the City of Winnipeg, Research and Standards Engineer. For Cold Weather Concrete, the use of fly ash will be permitted as additional to the cement unless authorized in writing by the City of Winnipeg, Research and Standards Engineer. The Contractor will have the option to replace cement up to but not exceeding the above limits, by weight of total cementitious materials, depending on the concrete type.

***Rapid chloride penetrability test will be required where there is evidence of concrete damage as a result of inadequate curing and adverse weather conditions, including hot weather, wind, rain, sleet, snow and cold weather. The Contract Administrator shall be allowed access to all sampling locations and reserves the right to take samples for testing at any time.

ASPHALTIC CONCRETE

Combined Aggregate Gradation Limits (Ref. TABLE 1 CW3410-R5.1)

Physical Requirements (Ref. TABLE 2 CW3410-R5.2)

COMBINED AGGREGATE GRADATION LIMITS				
Percent of Total Dry Weight Passing Each Sieve				
Canadian Metric Sieve Size	Type 1A (Surface Course) %	Type I (Surface Course) %	Type II (Surface Course) %	Type III (Base Course) %
40 000				100%
25 000	99% to 100%	100%		90% to 100%
16 000	--	--		60% to 90%
12 500	70% to 88%	70% to 85%	100%	56% to 80%
10 000	55% to 70%	45% to 70%	90% to 95%	--
5 000	40% to 60%	25% to 55%	74% to 80%	29% to 59%
2 500	25% to 50%	20% to 40%	55% to 64%	20% to 50%
1 250	15% to 40%	15% to 30%	35% to 46%	--
630	5% to 28%	5% to 20%	22% to 30%	15% to 30%
315	4% to 11%	--	--	5% to 17%
160	3% to 7%	3% to 6%	8% to 11%	--
80				1% to 7%
Crush Count:	60% min.	50% min.	--	60% min.
(Clause 5.4.1 (b) (iii))	(2 fractured faces)	(1 fractured face)		(2 fractured faces)

PHYSICAL REQUIREMENTS			
	Type 1A (Surface Course) %	Type I (Surface Course) %	Type II (Surface Course) %
Asphalt Cement, % total sample	5.0% to 6.0%	5.0% to 6.0%	5.0% to 7.0%
Voids in Mineral Aggregate, VMA	14.0% min.	14.5% min.	16.0% min.
Air Voids	3.0% to 5.0%	2.5% to 5.0%	2.5% to 5.0%
Marshall Stability, kN at 60°C	7 min.	5 min.	4 min.
Flow Index, units of 250 µm	6.0 to 16.0	6.0 to 16.0	6.0 to 16.0
			5 min.
			6.0 to 16.0
			4.0% to 5.5%
			12.0% min.
			2.5% to 5.0%

DENSITIES, BOULEVARD & APPROACH SETTLEMENT

Standard Proctor Densities

Standard Proctor Densities are a measure of soils density obtained using industry standard tests. The Standard Proctor Density for a soil is unique to that soil type. A sandy soil compacted to 100% Standard Proctor Density would not be as dense as a soil with a greater clay content compacted to the same 100% Standard Proctor Density.

Engineering consultants can determine soil densities and compaction (percent of Standard Proctor Density) at a cost.

A general rule of thumb can be applied to most soils to determine the approximate degree of compaction. A simple procedure is to try to penetrate the compacted soil with a common screwdriver. The screwdriver blade should be placed in contact with the soil and then hand force applied to the screwdriver to penetrate the soil. For Suitable Site sub-grade materials compacted to 95% Standard Proctor Density it should take considerable force to make the screwdriver penetrate the soil 50-75mm. For a base course material compacted to 100% Standard Proctor Density the screwdriver should only penetrate the soil approximately 25mm.

Boulevard and Approach Settlement

Water, sewer and other utility trenches exist in most boulevards in the City of Winnipeg. Long term settlement of the trench backfill material can occur even though steps have been taken during the utility installation to ensure that compaction of the backfill material was in accordance with Standard Construction Specifications.

Over time boulevard and approach settlement can occur that might adversely affect a private approach. It is therefore recommended that the sub-grade material in the boulevard and under the approach be examined and preventative measures such as sub-grade compaction by jetting and flooding or proper mechanical means and methods be performed prior to constructing a private approach.

Special attention should be given to sewer manholes and catch basins that will lie within the limits of an approach. Backfill around manholes may be more susceptible to settlement. **Where a manhole or catch basin exists, manhole and catch basin isolations must be included in the construction of the approach.** A manhole or catch basin which is not isolated will act as a pile under the approach which can lead to serious undermining followed by high severity cracking of the approach when settlement ultimately does occur.

Property owners/licensed contractors should also consider design alternatives above the minimum standards to minimize the effect of long-term trench and approach settlement.

APPROACH DETAILS

TO USE THE DETAIL CHARTS (**PAGES 28 & 29**) TO DETERMINE WHICH APPROACH DETAIL IS APPLICABLE. FOLLOW THESE STEPS:

STEP 1 Determine your land usage:

-for Residential or Farm property use Chart I.

-for Commercial, Industrial or any other property use Chart II.

STEP 2 Verify:

a) The type of pavement of the Street to which the approach will access:

-Concrete or Asphalt over Concrete,

-Asphalt, or

-Gravel / Chip seal

b) The type of curb if any:

-Barrier (rectangular with a vertical face)

-Lip (rolled with a diagonal face)

c) The shoulder type if applicable:

-Asphalt, or

-Gravel / Chip seal

Use the information from a, b & c, starting from the left to select the proper row.

STEP 3 Determine whether the Street to which the approach will access is considered Regional or Non-Regional. (see '*DEFINITIONS*' for Regional Streets (**page 2**))

Use this information to select the appropriate side of the table.

STEP 4 In the row you selected in step 2, on the side you select in step 3, locate the cell containing the surface material type you intend to use.

Note: The listed types are the option available to conform to the Private Access By-law.

The figure number in this cell will reference the applicable detail.

Chart I – Residential / Farm

		LAND USE RESIDENTIAL / FARM												
		REGIONAL STREETS					NON-REGIONAL STREETS							
PAVEMENT TYPE	CURB TYPE	SHOULDER TYPE	CONCRETE		PAVING STONES		CONCRETE		PAVING STONES		CONCRETE		PAVING STONES	
CONCRETE OR ASPHALT OVER CONCRETE	BARRIER CURB	NONE	CONCRETE FIG. 1		PAVING STONES FIG. 2		CONCRETE FIG. 11		PAVING STONES FIG. 12		CONCRETE FIG. 14		PAVING STONES FIG. 15	
	LIP CURB	NONE	CONCRETE FIG. 4		PAVING STONES FIG. 5		CONCRETE FIG. 17		PAVING STONES FIG. 18		CONCRETE FIG. 19		PAVING STONES FIG. 20	
	NONE	ASPHALT	CONCRETE FIG. 7		PAVING STONES FIG. 8		CONCRETE FIG. 13		PAVING STONES FIG. 14		CONCRETE FIG. 16		PAVING STONES FIG. 17	
	NONE	GRAVEL	GRAVEL FIG. 10	ASPHALT FIG. 9	CONCRETE FIG. 7	PAVING STONES FIG. 8	GRAVEL FIG. 20	ASPHALT FIG. 19	CONCRETE FIG. 17	CONCRETE FIG. 11	CONCRETE FIG. 14	CONCRETE FIG. 16	CONCRETE FIG. 17	CONCRETE FIG. 19
ASPHALT	BARRIER CURB	NONE	ASPHALT FIG. 3	CONCRETE FIG. 1	PAVING STONES FIG. 2	ASPHALT FIG. 13	CONCRETE FIG. 11	CONCRETE FIG. 14	CONCRETE FIG. 15	CONCRETE FIG. 17	CONCRETE FIG. 19	CONCRETE FIG. 17	CONCRETE FIG. 19	CONCRETE FIG. 17
	LIP CURB	NONE	ASPHALT FIG. 6	CONCRETE FIG. 4	PAVING STONES FIG. 5	ASPHALT FIG. 16	CONCRETE FIG. 14	CONCRETE FIG. 15	CONCRETE FIG. 17	CONCRETE FIG. 17	CONCRETE FIG. 19	CONCRETE FIG. 17	CONCRETE FIG. 19	CONCRETE FIG. 19
	NONE	ASPHALT	ASPHALT FIG. 9	CONCRETE FIG. 7	PAVING STONES FIG. 8	ASPHALT FIG. 19	CONCRETE FIG. 17	CONCRETE FIG. 17	CONCRETE FIG. 17	CONCRETE FIG. 17	CONCRETE FIG. 17	CONCRETE FIG. 17	CONCRETE FIG. 17	CONCRETE FIG. 17
	NONE	GRAVEL	GRAVEL FIG. 10	ASPHALT FIG. 9	CONCRETE FIG. 7	PAVING STONES FIG. 8	GRAVEL FIG. 20	ASPHALT FIG. 19	CONCRETE FIG. 17	CONCRETE FIG. 17	CONCRETE FIG. 17	CONCRETE FIG. 17	CONCRETE FIG. 17	CONCRETE FIG. 17
GRAVEL OR CHIP SEAL	NONE	GRAVEL OR CHIP SEAL / NONE	GRAVEL FIG. 10											

Chart II – Commercial / Industrial

		LAND USE					
		COMMERCIAL / INDUSTRIAL		NON-REGIONAL STREETS			
		REGIONAL STREETS					
PAVEMENT TYPE	CURB TYPE	SHOULDER TYPE					
CONCRETE OR ASPHALT OVER CONCRETE	BARRIER CURB	NONE	CONCRETE FIG. 1	PAVING STONES FIG. 2	CONCRETE FIG. 1	PAVING STONES FIG. 2	
	LIP CURB	NONE	CONCRETE FIG. 4	PAVING STONES FIG. 5	CONCRETE FIG. 4	PAVING STONES FIG. 5	
	NONE	ASPHALT	CONCRETE FIG. 7	PAVING STONES FIG. 8	CONCRETE FIG. 7	PAVING STONES FIG. 8	
	NONE	NONE	GRAVEL	CONCRETE FIG. 7	PAVING STONES FIG. 8	CONCRETE FIG. 7	PAVING STONES FIG. 8
ASPHALT	BARRIER CURB	NONE	ASPHALT FIG. 3	CONCRETE FIG. 1	PAVING STONES FIG. 2	CONCRETE FIG. 1	PAVING STONES FIG. 2
	LIP CURB	NONE	ASPHALT FIG. 6	CONCRETE FIG. 4	PAVING STONES FIG. 5	CONCRETE FIG. 4	PAVING STONES FIG. 5
	NONE	ASPHALT	ASPHALT FIG. 9	CONCRETE FIG. 7	PAVING STONES FIG. 8	CONCRETE FIG. 7	PAVING STONES FIG. 8
	NONE	NONE	GRAVEL	CONCRETE FIG. 7	PAVING STONES FIG. 8	CONCRETE FIG. 7	PAVING STONES FIG. 8
GRAVEL OR CHIP SEAL	NONE	GRAVEL OR CHIP SEAL / NONE	GRAVEL FIG. 10	GRAVEL FIG. 10	GRAVEL FIG. 10	GRAVEL FIG. 10	

Figure 1: Regional Streets with Barrier Curb

1.) Commercial & Residential (on Regional Streets) Concrete Approach

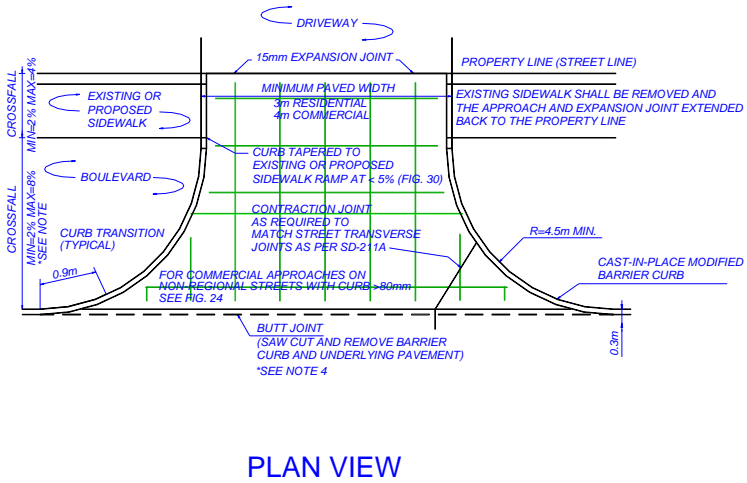

PLAN VIEW

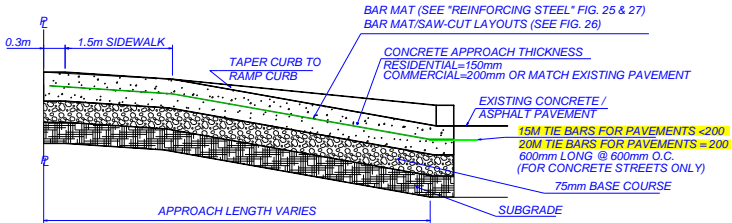

LONGITUDINAL SECTION

NOTE

- 1) SEE FIG. 22 & 23 FOR MANHOLE/CURB INLET ISOLATION DETAIL, IF REQUIRED.
- 2) WHEN REPLACING THE CONNECTING SIDEWALK AT AN APPROACH, THE SIDEWALK MUST MAINTAIN A 5% GRADE OR LESS (EXTRA PANELS MAY NEED TO BE REMOVED).
- 3) A CROSSFALL OF 2-4% WILL BE REQUIRED THROUGHOUT THE ENTIRE APPROACH WHERE PROPOSED SIDEWALKS WILL BE CONSTRUCTED AT THE PROPERTY LINE. THIS APPLIES TO NEWLY INSTALLED OR PROPOSED SIDEWALKS IN NEW DEVELOPMENTS.
- 4) IF EXISTING STREET HAS CURB AND GUTTER, THE ENTIRE CURB AND GUTTER WILL NEED TO BE REMOVED AND REPLACED AS PER SD-200.

Reference Spec No. CW 3230, CW 3310
N.T.S.

***NOTE: A Commercial approach can also be located on a Non-Regional street since it could be based on property type, this detail is still to be followed for these situations unless the approved drawing from Transportation shows otherwise.**

Figure 2: Regional Streets with Barrier Curb

2.) Commercial & Residential (on Regional Streets) Paving Stone Approach

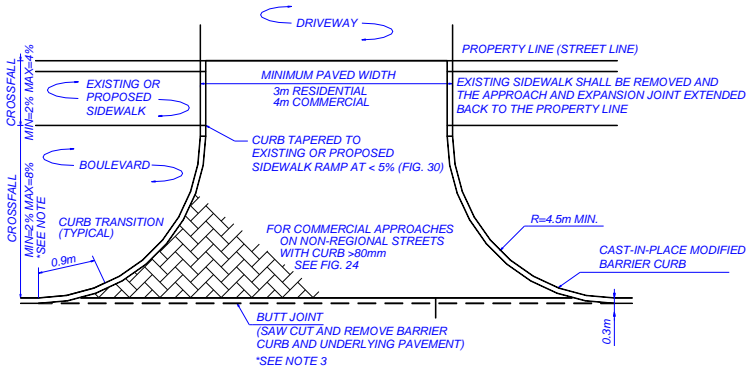

PLAN VIEW

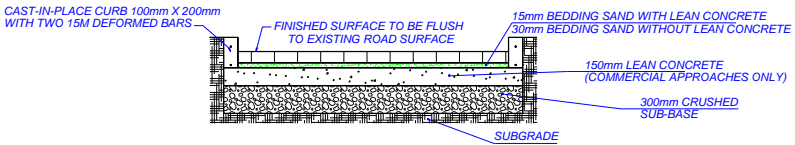

CROSS SECTION

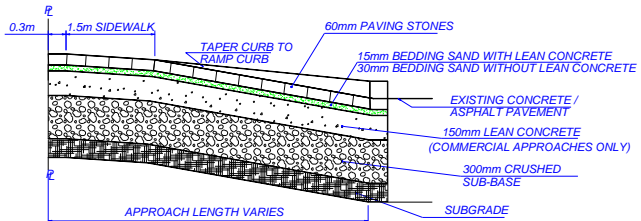

LONGITUDINAL SECTION

NOTE

- 1) WHEN REPLACING THE CONNECTING SIDEWALK AT AN APPROACH, THE SIDEWALK MUST MAINTAIN A 5% GRADE OR LESS (EXTRA PANELS MAY NEED TO BE REMOVED)
- 2) A CROSSFALL OF 2-4% WILL BE REQUIRED THROUGHOUT THE ENTIRE APPROACH WHERE PROPOSED SIDEWALKS WILL BE CONSTRUCTED AT THE PROPERTY LINE. THIS APPLIES TO NEWLY INSTALLED OR PROPOSED SIDEWALKS IN NEW DEVELOPMENTS.
- 3) IF EXISTING STREET HAS CURB AND GUTTER, THE ENTIRE CURB AND GUTTER WILL NEED TO BE REMOVED AND REPLACED AS PER SD-200.

Reference Spec No. CW 3240, CW 3110, CW 3335, CW 3330
N.T.S.

***NOTE: A Commercial approach can also be located on a Non-Regional street since it could be based on property type, this detail is still to be followed for these situations unless the approved drawing from Transportation shows otherwise.**

Figure 3: Regional Streets with Barrier Curb

3.) Commercial & Residential (on Regional Streets) Asphalt Approach

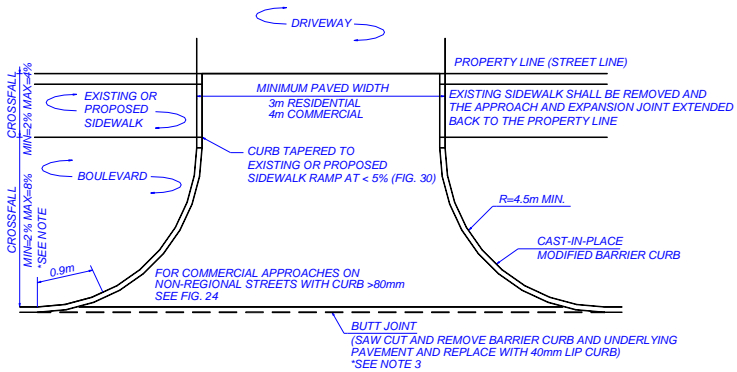

PLAN VIEW

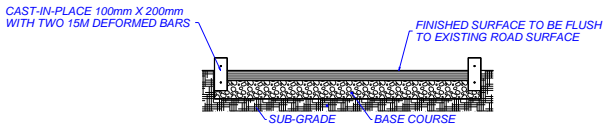

CROSS SECTION

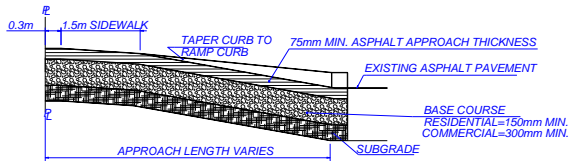

LONGITUDINAL SECTION

NOTE

- 1) WHEN REPLACING THE CONNECTING SIDEWALK AT AN APPROACH, THE SIDEWALK MUST MAINTAIN A 5% GRADE OR LESS (EXTRA PANELS MAY NEED TO BE REMOVED)
- 2) A CROSSFALL OF 2-4% WILL BE REQUIRED THROUGHOUT THE ENTIRE APPROACH WHERE PROPOSED SIDEWALKS WILL BE CONSTRUCTED AT THE PROPERTY LINE. THIS APPLIES TO NEWLY INSTALLED OR PROPOSED SIDEWALKS IN NEW DEVELOPMENTS.
- 3) IF EXISTING STREET HAS CURB AND GUTTER, THE ENTIRE CURB AND GUTTER WILL NEED TO BE REMOVED AND REPLACED AS PER SD-200.

Reference Spec No. CW 3240, CW 3310, CW 3110, CW 3410
N.T.S.

***NOTE: A Commercial approach can also be located on a Non-Regional street since it could be based on property type, this detail is still to be followed for these situations unless the approved drawing from Transportation shows otherwise.**

Figure 4: Regional Streets with Lip Curb

1.) Commercial & Residential (on Regional Streets) Concrete Approach

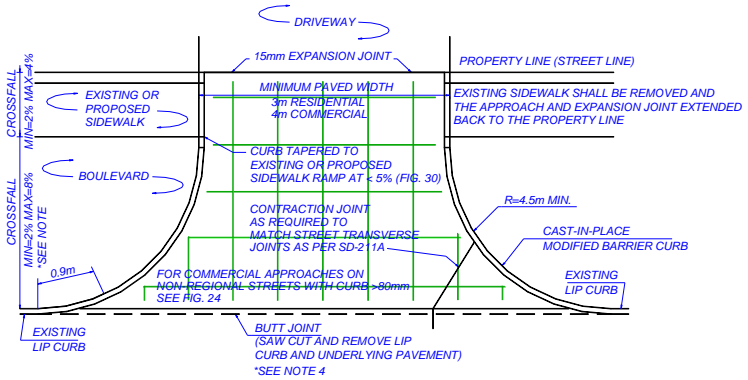

PLAN VIEW

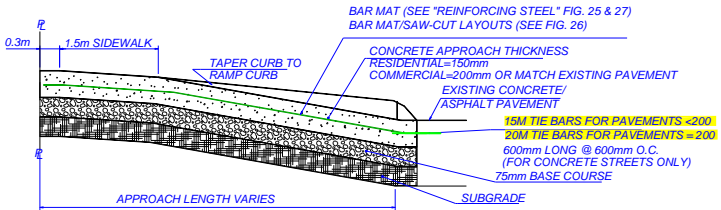

LONGITUDINAL SECTION

NOTE

- 1) SEE FIG. 22 & 23 FOR MANHOLE/CURB INLET ISOLATION DETAIL IF REQUIRED.
- 2) WHEN REPLACING THE CONNECTING SIDEWALK AT AN APPROACH, THE SIDEWALK MUST MAINTAIN A 5% GRADE OR LESS (EXTRA PANELS MAY NEED TO BE REMOVED).
- 3) A CROSSFALL OF 2-4% WILL BE REQUIRED THROUGHOUT THE ENTIRE APPROACH WHERE PROPOSED SIDEWALKS WILL BE CONSTRUCTED AT THE PROPERTY LINE. THIS APPLIES TO NEWLY INSTALLED OR PROPOSED SIDEWALKS IN NEW DEVELOPMENTS.
- 4) IF EXISTING STREET HAS CURB AND GUTTER, THE ENTIRE CURB AND GUTTER WILL NEED TO BE REMOVED AND REPLACED AS PER SD-200.

Reference Spec No. CW 3230, CW 3310
N.T.S.

***NOTE: A Commercial approach can also be located on a Non-Regional street since it could be based on property type, this detail is still to be followed for these situations unless the approved drawing from Transportation shows otherwise.**

Figure 5: Regional Streets with Lip Curb

2.) Commercial & Residential (on Regional Streets) Paving Stone Approach

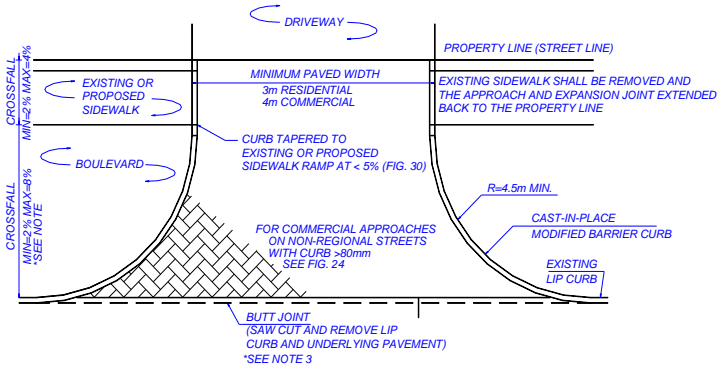

PLAN VIEW

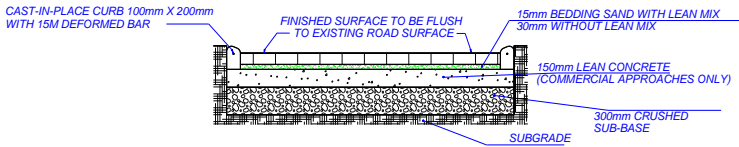

CROSS SECTION

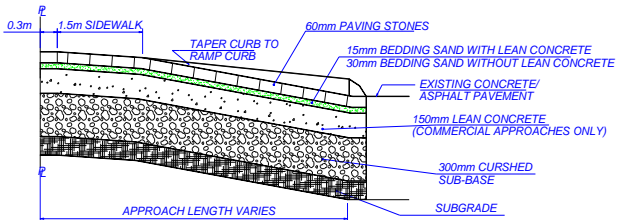

LONGITUDINAL SECTION

NOTE

- 1) WHEN REPLACING THE CONNECTING SIDEWALK AT AN APPROACH, THE SIDEWALK MUST MAINTAIN A 5% GRADE OR LESS (EXTRA PANELS MAY NEED TO BE REMOVED)
- 2) A CROSSFALL OF 2-4% WILL BE REQUIRED THROUGHOUT THE ENTIRE APPROACH WHERE PROPOSED SIDEWALKS WILL BE CONSTRUCTED AT THE PROPERTY LINE. THIS APPLIES TO NEWLY INSTALLED OR PROPOSED SIDEWALKS IN NEW DEVELOPMENTS.
- 3) IF EXISTING STREET HAS CURB AND GUTTER, THE ENTIRE CURB AND GUTTER WILL NEED TO BE REMOVED AND REPLACED AS PER SD-200.

Reference Spec No. CW 3230, CW 3110, CW 3335, CW 3330
N.T.S.

***NOTE: A Commercial approach can also be located on a Non-Regional street since it could be based on property type, this detail is still to be followed for these situations unless the approved drawing from Transportation shows otherwise.**

Figure 6: Regional Streets with Lip Curb

3.) Commercial & Residential (on Regional Streets) Asphalt Approach

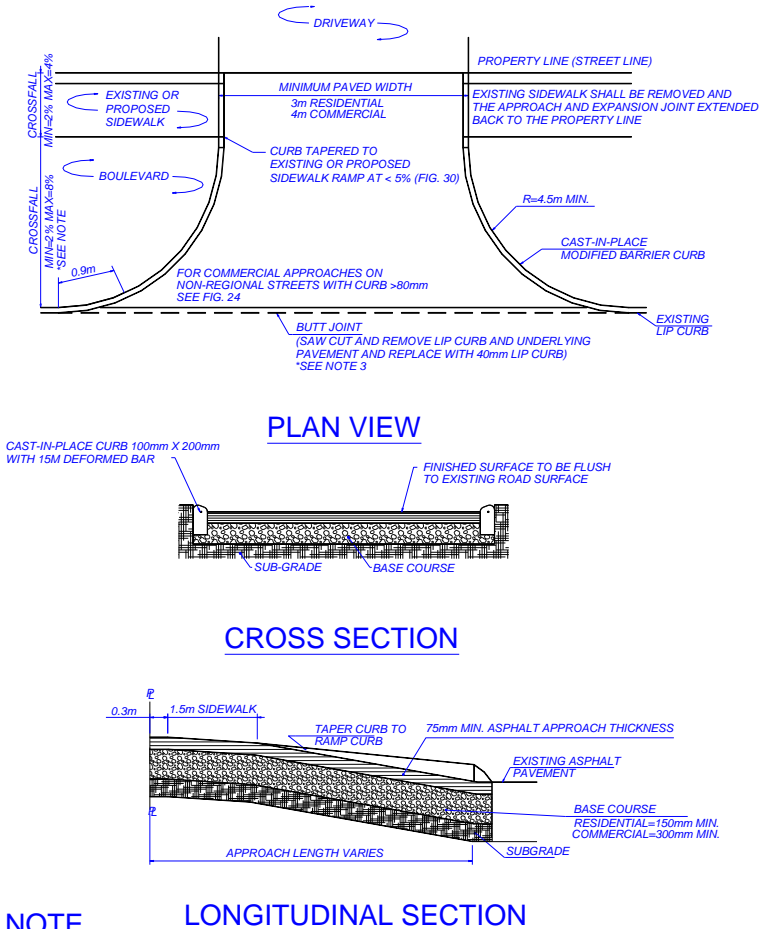

NOTE

- 1) WHEN REPLACING THE CONNECTING SIDEWALK AT AN APPROACH, THE SIDEWALK MUST MAINTAIN A 5% GRADE OR LESS (EXTRA PANELS MAY NEED TO BE REMOVED)
- 2) A CROSSFALL OF 2-4% WILL BE REQUIRED THROUGHOUT THE ENTIRE APPROACH WHERE PROPOSED SIDEWALKS WILL BE CONSTRUCTED AT THE PROPERTY LINE. THIS APPLIES TO NEWLY INSTALLED OR PROPOSED SIDEWALKS IN NEW DEVELOPMENTS.
- 3) IF EXISTING STREET HAS CURB AND GUTTER, THE ENTIRE CURB AND GUTTER WILL NEED TO BE REMOVED AND REPLACED AS PER SD-200.

Reference Spec No.
CW 3240, CW 3310,
CW 3110, CW 3410

N.T.S.

***NOTE: A Commercial approach can also be located on a Non-Regional street since it could be based on property type, this detail is still to be followed for these situations unless the approved drawing from Transportation shows otherwise.**

Figure 7: Regional Streets with Shoulders

1.) Commercial & Residential (on Regional Streets) Concrete Approach

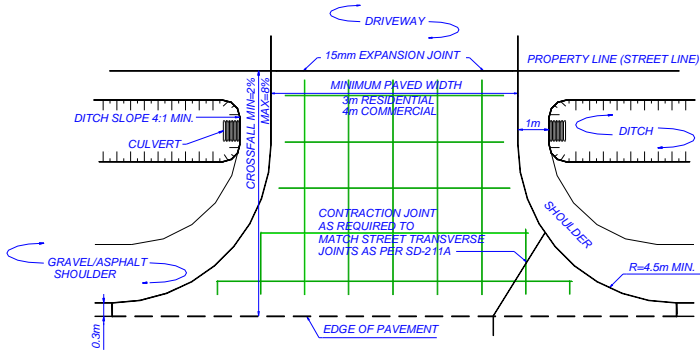

PLAN VIEW

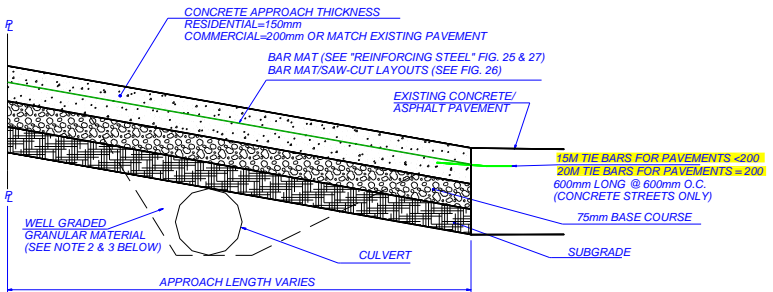

LONGITUDINAL SECTION

NOTE

- 1) SEE FIG. 22 & 23 FOR MANHOLE/CURB INLET ISOLATION DETAIL, IF REQUIRED.
- 2) CAP SIDE SLOPES AROUND THE CULVERT ENDS WITH IMPERVIOUS CLAY.
- 3) CULVERT END MARKERS ARE TO BE INSTALLED ON THE ENDS OF THE CULVERT AS PER CW3610.

Reference Spec No.
CW 3230, CW 3310,
CW 3610

N.T.S.

***NOTE: A Commercial approach can also be located on a *Non-Regional* street since it could be based on property type, this detail is still to be followed for these situations unless the approved drawing from Transportation shows otherwise.**

Figure 8: Regional Streets with Shoulders

2.) Commercial & Residential (on Regional Streets) Paving Stone Approach

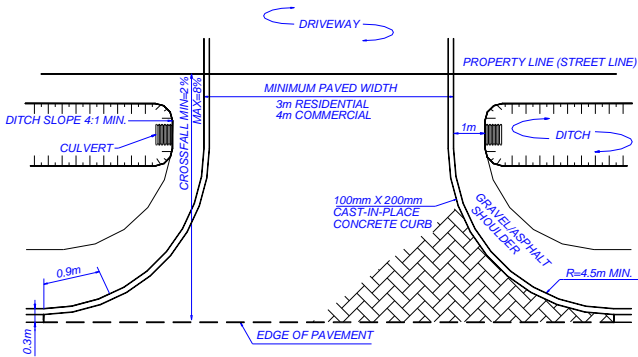

PLAN VIEW

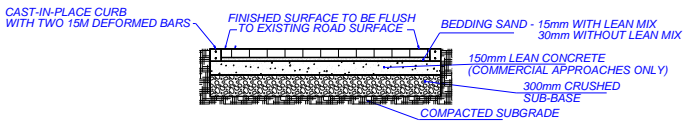

CROSS SECTION

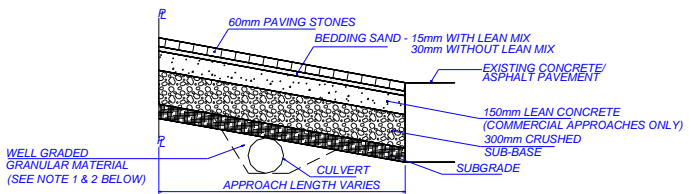

LONGITUDINAL SECTION

NOTE

- 1) CAP SIDE SLOPES AROUND THE CULVERT ENDS WITH IMPERVIOUS CLAY.
- 2) CULVERT END MARKERS ARE TO BE INSTALLED ON THE ENDS OF THE CULVERT AS PER CW3610.

Reference Spec No. CW 3330, CW 3110, CW 3335, CW 3610
N.T.S.

***NOTE: A Commercial approach can also be located on a Non-Regional street since it could be based on property type, this detail is still to be followed for these situations unless the approved drawing from Transportation shows otherwise.**

Figure 9: Regional Streets with Shoulders

3.) Commercial & Residential (on Regional Streets) Asphalt Approach

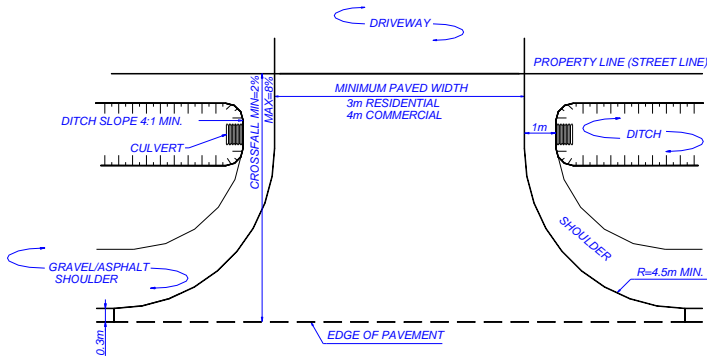

PLAN VIEW

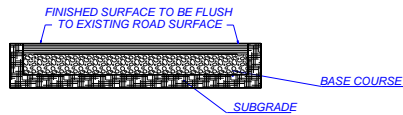

CROSS SECTION

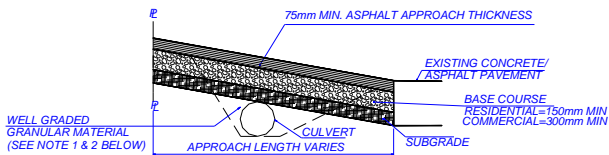

LONGITUDINAL SECTION

NOTE

- 1) CAP SIDE SLOPES AROUND THE CULVERT ENDS WITH IMPERVIOUS CLAY.
- 2) CULVERT END MARKERS ARE TO BE INSTALLED ON THE ENDS OF THE CULVERT AS PER CW3610.

Reference Spec No. CW 3240, CW 3610, CW 3110, CW 3410
N.T.S.

***NOTE: A Commercial approach can also be located on a Non-Regional street since it could be based on property type, this detail is still to be followed for these situations unless the approved drawing from Transportation shows otherwise.**

Figure 10: Regional Streets with Shoulders

4.) Commercial & Residential (on Regional Streets) Gravel Approach

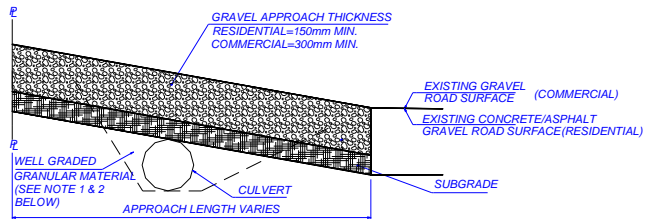
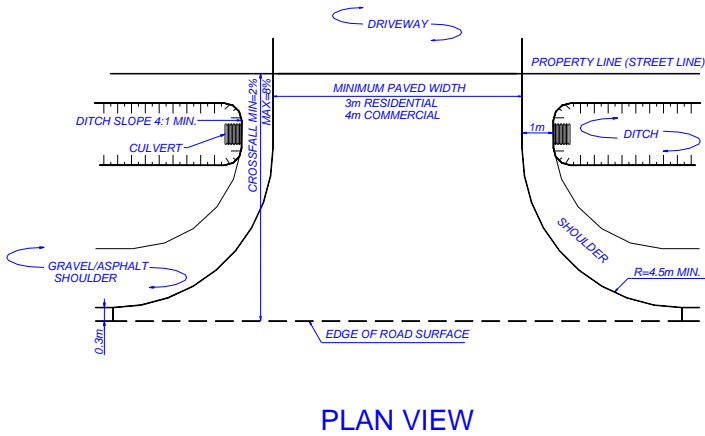

NOTE

- 1) CAP SIDE SLOPES AROUND THE CULVERT ENDS WITH IMPERVIOUS CLAY.
- 2) CULVERT END MARKERS ARE TO BE INSTALLED ON THE ENDS OF THE CULVERT AS PER CW3610.

Reference Spec No. CW 3240, CW 3610, CW 3110, CW 3410
N.T.S.

***NOTE: A Commercial approach can also be located on a Non-Regional street since it could be based on property type, this detail is still to be followed for these situations unless the approved drawing from Transportation shows otherwise.**

Figure 11: Non-Regional Streets with Barrier Curb

1.) Residential Concrete Approach

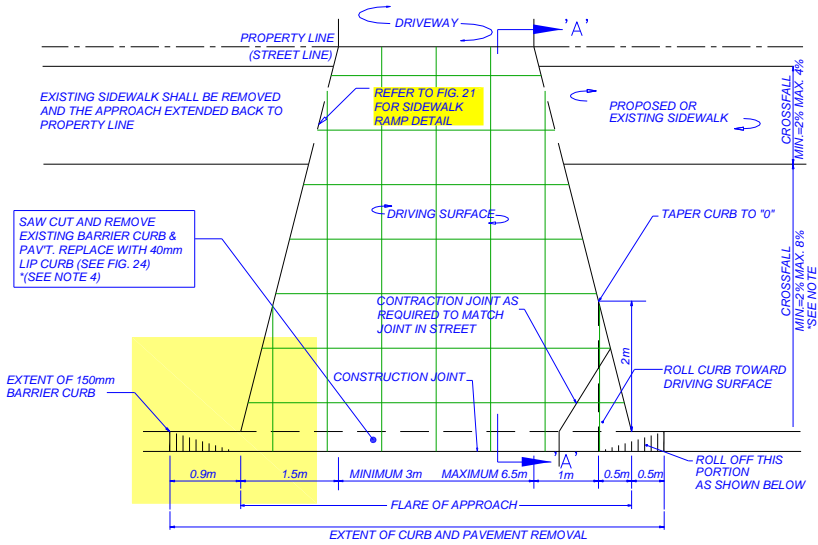

PLAN VIEW

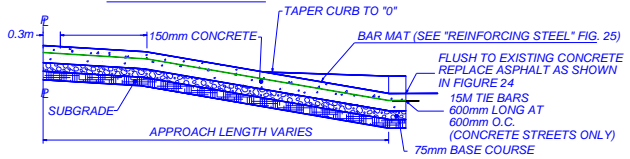

CROSS SECTION

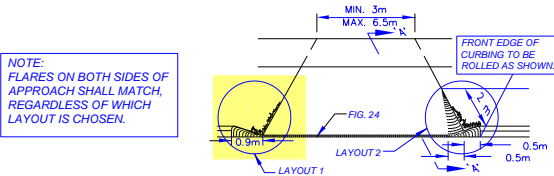

FRONTAL PERSPECTIVE OF FINISHED PRIVATE APPROACH

NOTE

- 1) SEE FIG. 22 & 23 FOR MANHOLE/CURB INLET ISOLATION DETAIL IF REQUIRED.
- 2) WHEN REPLACING THE CONNECTING SIDEWALK AT AN APPROACH, THE SIDEWALK MUST MAINTAIN A 5% GRADE OR LESS (EXTRA PANELS MAY NEED TO BE REMOVED).
- 3) A CROSSFALL OF 2-4% WILL BE REQUIRED THROUGHOUT THE ENTIRE APPROACH WHERE PROPOSED SIDEWALKS WILL BE CONSTRUCTED AT THE PROPERTY LINE. THIS APPLIES TO NEWLY INSTALLED OR PROPOSED SIDEWALKS IN NEW DEVELOPMENTS.
- 4) IF EXISTING STREET HAS CURB AND GUTTER, THE ENTIRE CURB AND GUTTER WILL NEED TO BE REMOVED AND REPLACED AS PER SD-200.

Reference Spec No. CW 3230, CW 3310, CW 3240
N.T.S.

Figure 12: Non-Regional Streets with Barrier Curb

2.) Residential Paving Stone Approach

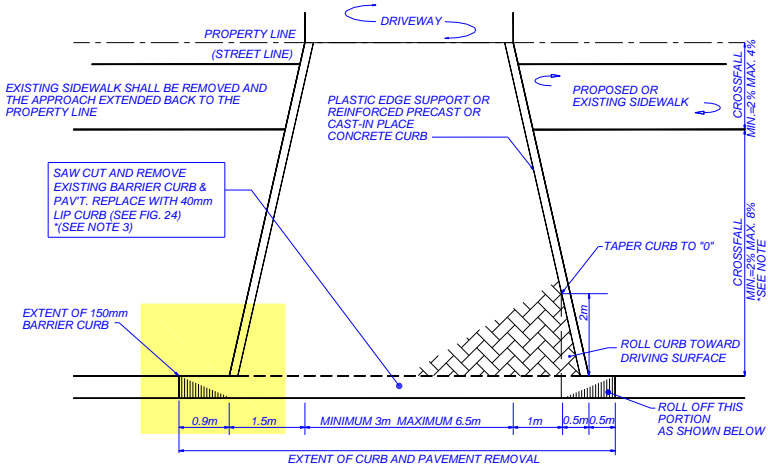

PLAN VIEW

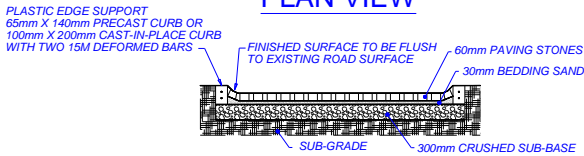

CROSS SECTION

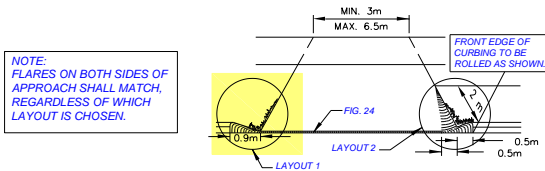

FRONTAL PERSPECTIVE OF FINISHED PRIVATE APPROACH

NOTE

- 1) WHEN REPLACING THE CONNECTING SIDEWALK AT AN APPROACH, THE SIDEWALK MUST MAINTAIN A 5% GRADE OR LESS (EXTRA PANELS MAY NEED TO BE REMOVED)
- 2) A CROSSFALL OF 2-4% WILL BE REQUIRED THROUGHOUT THE ENTIRE APPROACH WHERE PROPOSED SIDEWALKS WILL BE CONSTRUCTED AT THE PROPERTY LINE. THIS APPLIES TO NEWLY INSTALLED OR PROPOSED SIDEWALKS IN NEW DEVELOPMENTS.
- 3) IF EXISTING STREET HAS CURB AND GUTTER, THE ENTIRE CURB AND GUTTER WILL NEED TO BE REMOVED AND REPLACED AS PER SD-200.

Reference Spec No.
CW 3240, CW 3110,
CW 3335, CW 3330

N.T.S.

Figure 13: Non-Regional Streets with Barrier Curb

3.) Residential Asphalt Approach

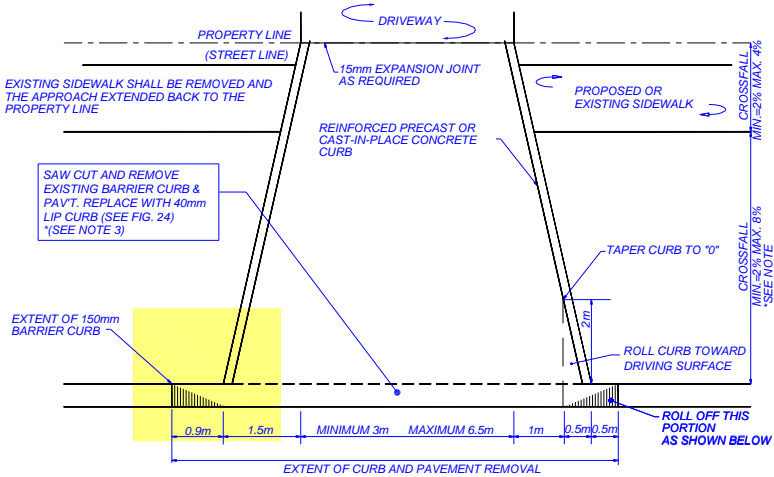

PLAN VIEW

65mm X 140mm PRECAST CURB OR 100mm X 200mm CAST-IN-PLACE CURB WITH TWO 15M DEFORMED BARS

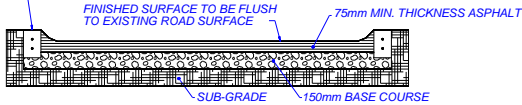

CROSS SECTION

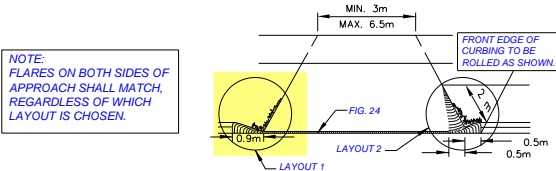

NOTE: FLARES ON BOTH SIDES OF APPROACH SHALL MATCH, REGARDLESS OF WHICH LAYOUT IS CHOSEN.

FRONTAL PERSPECTIVE OF FINISHED PRIVATE APPROACH

NOTE

- 1) WHEN REPLACING THE CONNECTING SIDEWALK AT AN APPROACH, THE SIDEWALK MUST MAINTAIN A 5% GRADE OR LESS (EXTRA PANELS MAY NEED TO BE REMOVED)
- 2) A CROSSFALL OF 2-4% WILL BE REQUIRED THROUGHOUT THE ENTIRE APPROACH WHERE PROPOSED SIDEWALKS WILL BE CONSTRUCTED AT THE PROPERTY LINE. THIS APPLIES TO NEWLY INSTALLED OR PROPOSED SIDEWALKS IN NEW DEVELOPMENTS.
- 3) IF EXISTING STREET HAS CURB AND GUTTER, THE ENTIRE CURB AND GUTTER WILL NEED TO BE REMOVED AND REPLACED AS PER SD-200.

Reference Spec No. CW 3240, CW 3610, CW 3110, CW 3410
N.T.S.

Figure 14: Non-Regional Streets with Lip Curb

1.) Residential Concrete Approach

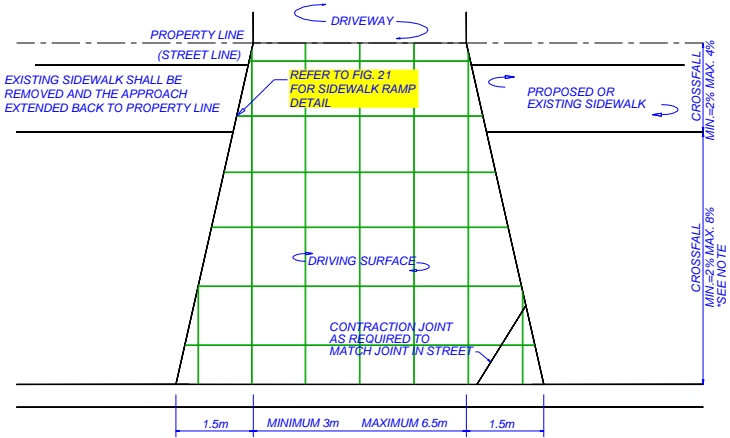

PLAN VIEW

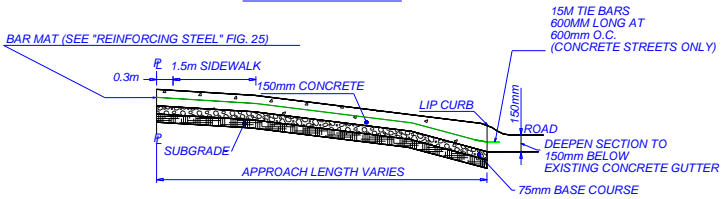

CROSS SECTION

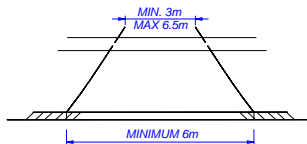

FRONTAL PERSPECTIVE OF FINISHED PRIVATE APPROACH

NOTE

- 1) SEE FIG. 22 & 23 FOR MANHOLE/CURB INLET ISOLATION DETAIL IF REQUIRED.
- 2) IF CURB HEIGHT >80mm REFER TO FIG. 24.
- 3) WHEN REPLACING THE CONNECTING SIDEWALK AT AN APPROACH, THE SIDEWALK MUST MAINTAIN A 5% GRADE OR LESS (EXTRA PANELS MAY NEED TO BE REMOVED).
- 4) A CROSSFALL OF 2-4% WILL BE REQUIRED THROUGHOUT THE ENTIRE APPROACH WHERE PROPOSED SIDEWALKS WILL BE CONSTRUCTED AT THE PROPERTY LINE. THIS APPLIES TO NEWLY INSTALLED OR PROPOSED SIDEWALKS IN NEW DEVELOPMENTS.

Reference Spec No. CW 3230, CW 3310, CW 3240
N.T.S.

Figure 15: Non-Regional Streets with Lip Curb

2.) Residential Paving Stone Approach

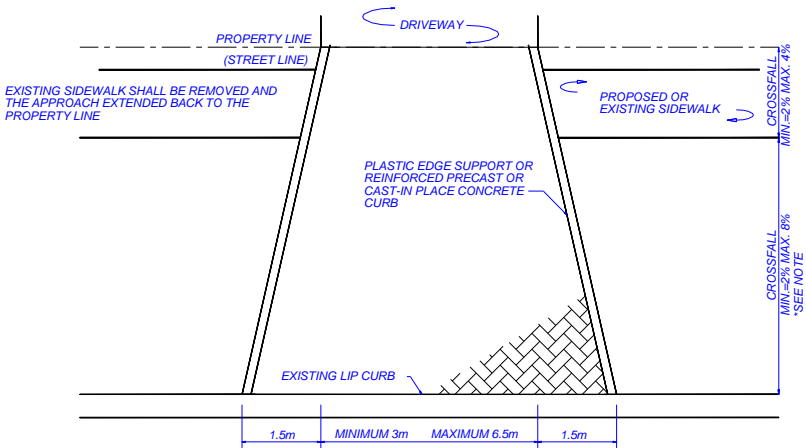

PLAN VIEW

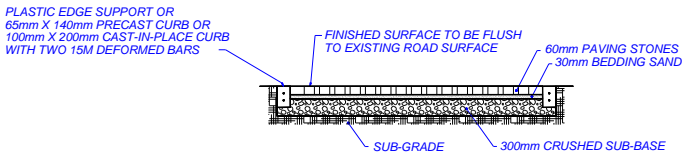

CROSS SECTION

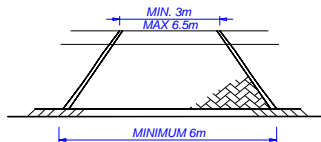

FRONTAL PERSPECTIVE OF FINISHED PRIVATE APPROACH

NOTE

- 1) IF CURB HEIGHT >80mm REFER TO FIG. 24
- 2) WHEN REPLACING THE CONNECTING SIDEWALK AT AN APPROACH, THE SIDEWALK MUST MAINTAIN A 5% GRADE OR LESS (EXTRA PANELS MAY NEED TO BE REMOVED)
- 3) A CROSSFALL OF 2-4% WILL BE REQUIRED THROUGHOUT THE ENTIRE APPROACH WHERE PROPOSED SIDEWALKS WILL BE CONSTRUCTED AT THE PROPERTY LINE. THIS APPLIES TO NEWLY INSTALLED OR PROPOSED SIDEWALKS IN NEW DEVELOPMENTS.

Reference Spec No.
CW 3240, CW 3110,
CW 3335, CW 3330

N.T.S.

Figure 16: Non-Regional Streets with Lip Curb

3.) Residential Asphalt Approach

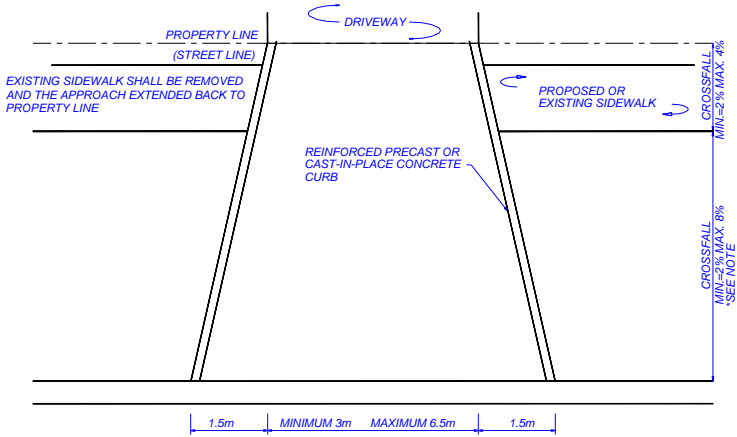

PLAN VIEW

65mm X 140mm PRECAST CURB OR
100mm X 200mm CAST-IN-PLACE CURB
WITH TWO 15M DEFORMED BARS

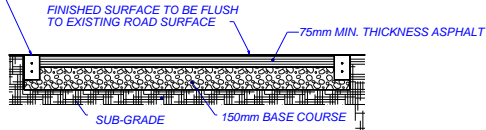

CROSS SECTION

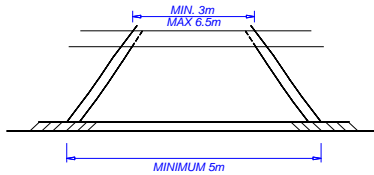

FRONTAL PERSPECTIVE OF FINISHED PRIVATE APPROACH

NOTE

- 1) IF CURB HEIGHT >80mm REFER TO FIG. 24
- 2) WHEN REPLACING THE CONNECTING SIDEWALK AT AN APPROACH, THE SIDEWALK MUST MAINTAIN A 5% GRADE OR LESS (EXTRA PANELS MAY NEED TO BE REMOVED)
- 3) A CROSSFALL OF 2-4% WILL BE REQUIRED THROUGHOUT THE ENTIRE APPROACH WHERE PROPOSED SIDEWALKS WILL BE CONSTRUCTED AT THE PROPERTY LINE. THIS APPLIES TO NEWLY INSTALLED OR PROPOSED SIDEWALKS IN NEW DEVELOPMENTS.

Reference Spec No. CW 3240, CW 3610, CW 3110, CW 3410
N.T.S.

Figure 17: Non-Regional Streets with Shoulders

1.) Residential Concrete Approach

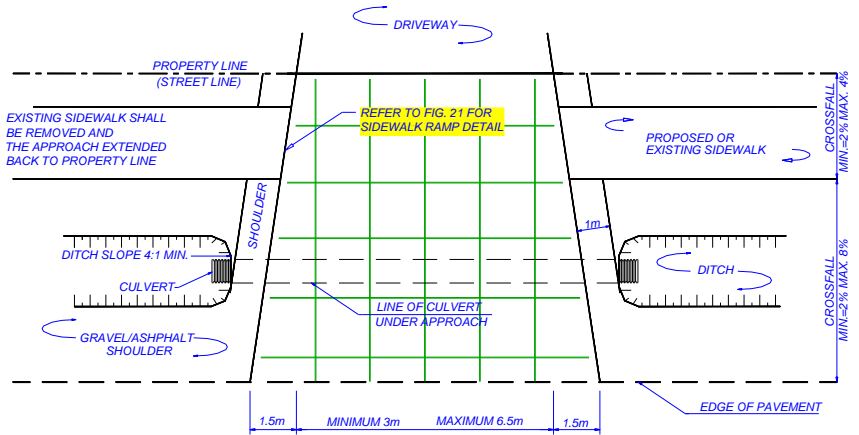

PLAN VIEW

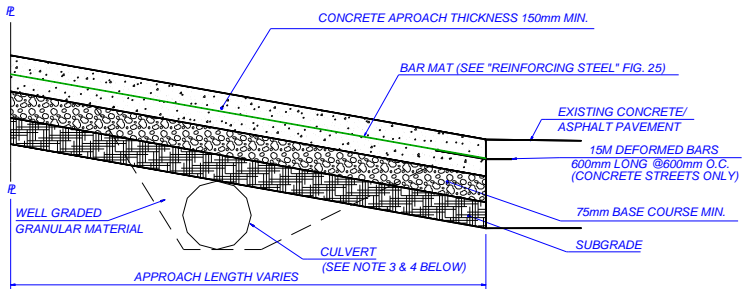

LONGITUDINAL SECTION

NOTE

- 1) SEE FIG. 22 & 23 FOR MANHOLE/CURB INLET ISOLATION DETAIL IF REQUIRED.
- 2) WHEN REPLACING THE CONNECTING SIDEWALK AT AN APPROACH, THE SIDEWALK MUST MAINTAIN A 5% GRADE OR LESS (EXTRA PANELS MAY NEED TO BE REMOVED)
- 3) CAP SIDE SLOPES AROUND THE CULVERT ENDS WITH IMPERVIOUS CLAY
- 4) CULVERT END MARKERS ARE TO BE INSTALLED ON THE ENDS OF THE CULVERT AS PER CW3610.

Reference Spec No. CW 3230, CW 3310, CW 3610
N.T.S.

Figure 18: Non-Regional Streets with Shoulders

2.) Residential Paving Stone Approach

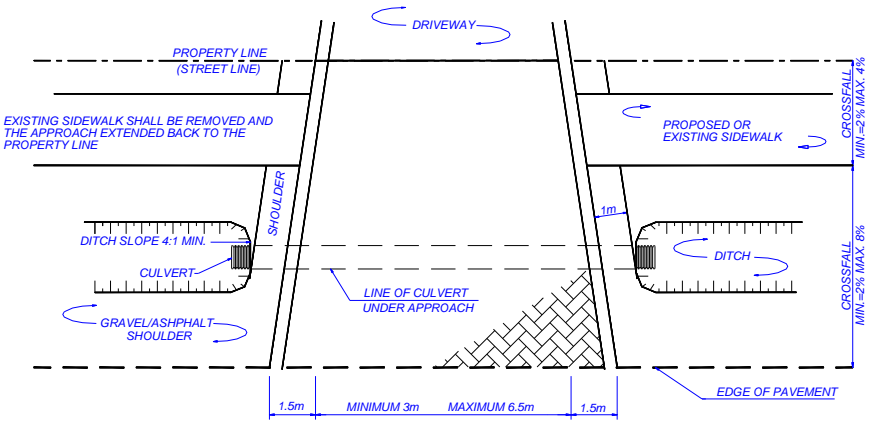

PLAN VIEW

PLASTIC EDGE SUPPORT OR
100mm X 200mm CAST-IN-PLACE CURB
100mm X 200mm CAST-IN-PLACE CURB
WITH TWO 15M DEFORMED BARS

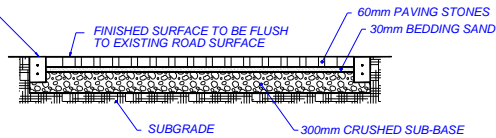

CROSS SECTION

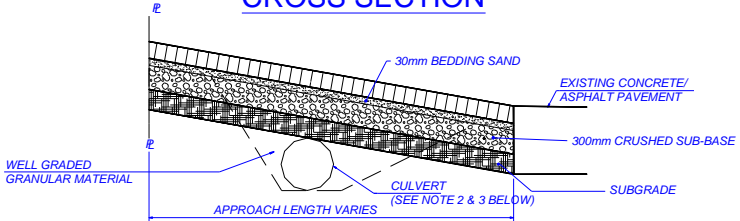

LONGITUDINAL SECTION

NOTE

- 1) WHEN REPLACING THE CONNECTING SIDEWALK AT AN APPROACH, THE SIDEWALK MUST MAINTAIN A 5% GRADE OR LESS (EXTRA PANELS MAY NEED TO BE REMOVED)
- 2) CAP SIDE SLOPES AROUND THE CULVERT ENDS WITH IMPERVIOUS CLAY
- 3) CULVERT END MARKERS ARE TO BE INSTALLED ON THE ENDS OF THE CULVERT AS PER CW3610.

Reference Spec No.
CW 3330, CW 3110,
CW 3335, CW 3610

N.T.S.

Figure 19: Non-Regional Streets with Shoulders

3.) Residential Asphalt Approach

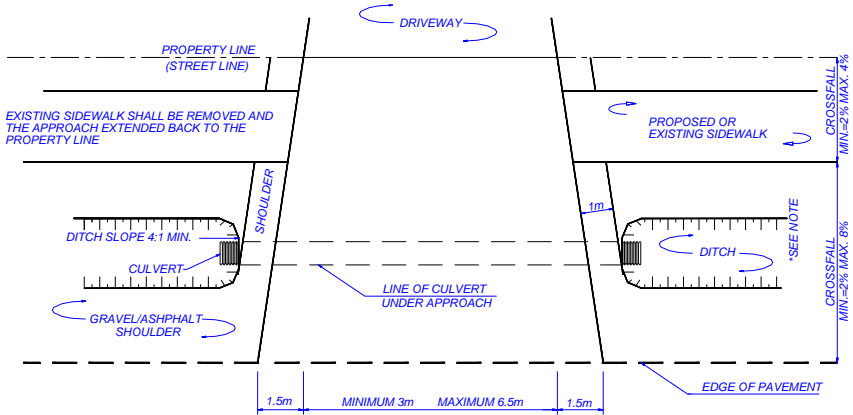

PLAN VIEW

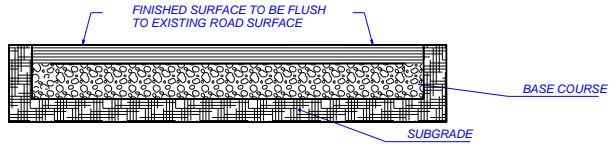

CROSS SECTION

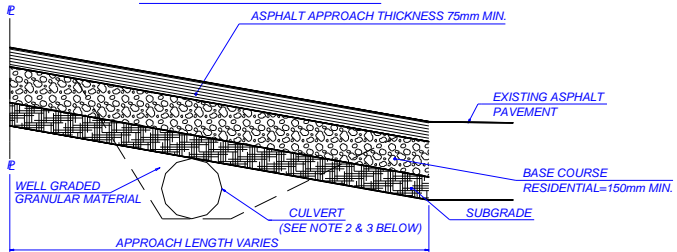

LONGITUDINAL SECTION

NOTE

- 1) WHEN REPLACING THE CONNECTING SIDEWALK AT AN APPROACH, THE SIDEWALK MUST MAINTAIN A 5% GRADE OR LESS (EXTRA PANELS MAY NEED TO BE REMOVED).
- 2) CAP SIDE SLOPES AROUND THE CULVERT ENDS WITH IMPERVIOUS CLAY
- 3) CULVERT END MARKERS ARE TO BE INSTALLED ON THE ENDS OF THE CULVERT AS PER CW3610.

Reference Spec No. CW 3240, CW 3610, CW 3110, CW 3410
N.T.S.

Figure 20: Non-Regional Streets with Shoulders

4.) Residential Gravel Approach

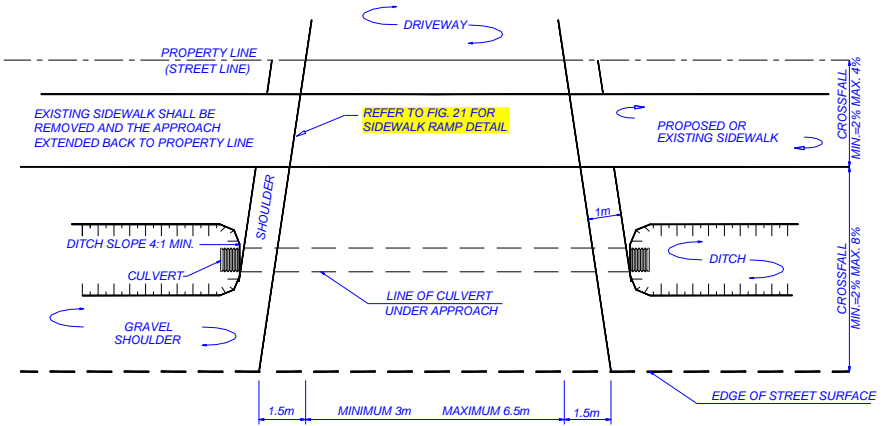

PLAN VIEW

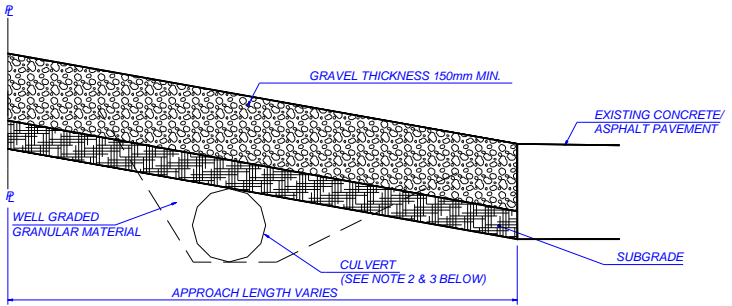

LONGITUDINAL SECTION

NOTE

- 1) WHEN REPLACING THE CONNECTING SIDEWALK AT AN APPROACH, THE SIDEWALK MUST MAINTAIN A 5% GRADE OR LESS (EXTRA PANELS MAY NEED TO BE REMOVED).
- 2) CAP SIDE SLOPES AROUND THE CULVERT ENDS WITH IMPERVIOUS CLAY
- 3) CULVERT END MARKERS ARE TO BE INSTALLED ON THE ENDS OF THE CULVERT AS PER CW3610.

Reference Spec No. CW 3240, CW 3610, CW 3110, CW 3410
N.T.S.

Figure 21

Public and Residential Concrete Sidewalk Ramp Detail

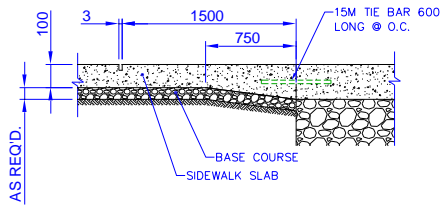
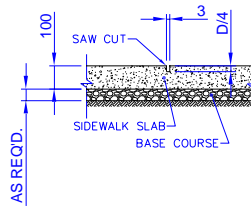
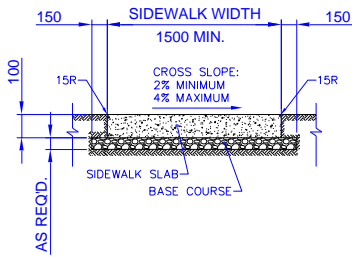
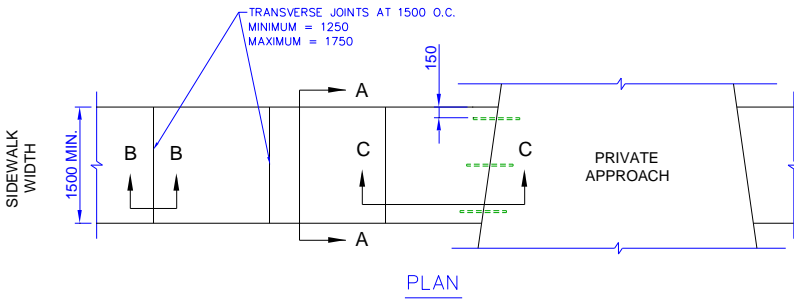

NOTE

- 1) SIDEWALK SLAB SURFACE WILL BE GIVEN A TEXTURED BROOM FINISH. NO EDGER MARKS WILL BE LEFT.
- 2) LONGITUDINAL JOINTS AT 1500 O.C. MAXIMUM
- 3) ALL DIMENSIONS IN MILLIMETERS
- 4) FOR PRIVATE APPROACHES WITH CURBS, CURB RAMPS SHALL BE INSTALLED

Reference Spec No.
CW 3235, CW 3310,
CW 3325

N.T.S.

Figure 22

Manhole Isolation Details for Concrete Approaches

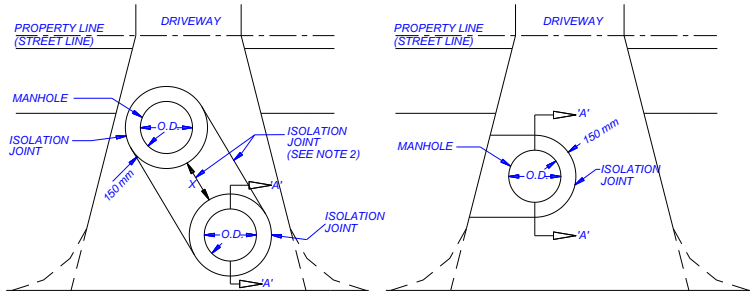

ISOLATION IF MANHOLE IS MORE THAN 600mm FROM EDGE OF APPROACH (MEASURING FROM THE PROPOSED ISOLATION)

ISOLATION IF MANHOLE IS LESS THAN 600mm FROM EDGE OF APPROACH

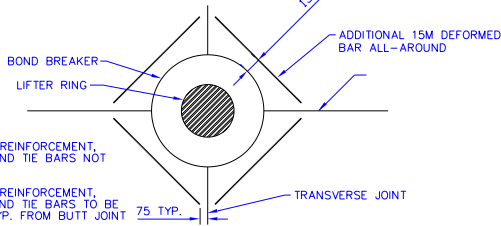

NOTE:

1. BAR MAT REINFORCEMENT, DOWELS AND TIE BARS NOT SHOWN
2. BAR MAT REINFORCEMENT, DOWELS AND TIE BARS TO BE 100mm TYP. FROM BUTT JOINT

PLAN VIEW

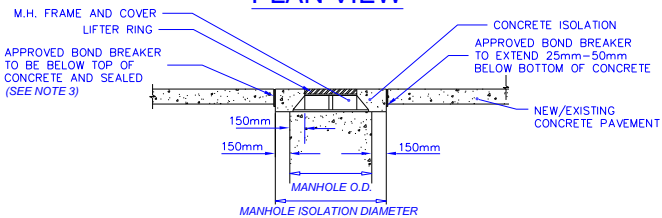

SECTION A - A

NOTE

- 1) MANHOLE ISOLATION DIAMETER (300mm from cover) = MANHOLE O.D. + 150mm + 150mm
- 2) DOUBLE MANHOLE ISOLATION NEEDED WHERE 'X' BETWEEN THE TWO MANHOLES/CATCH BASINS ARE LESS THAN 600mm. ISOLATIONS CAN BE SEPARATED WHERE DISTANCES ARE MORE THAN 600mm.
- 3) ISOLATIONS TO BE FORMED WITH A RIGID FORM BOARD AND POURED SEPERATELY. ONLY APPROVED MATERIALS FOR BOND BREAKER TO BE USED.

Reference Spec No. CW 3310
N.T.S.

Figure 23

Curb and Gutter Inlet Isolation Detail in Concrete/Asphalt Over Concrete Approaches

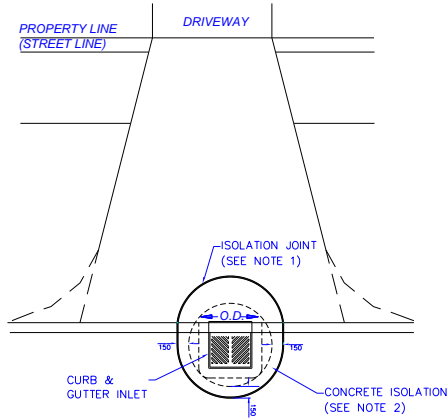

PLAN VIEW

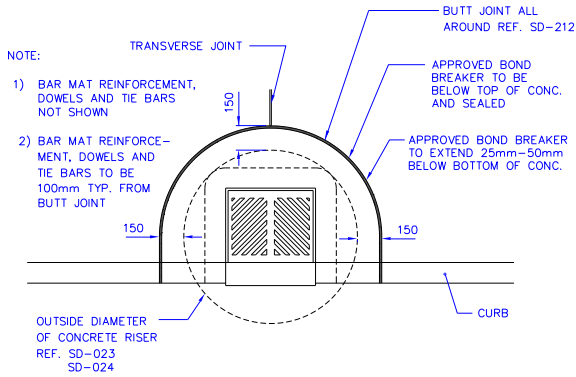

NOTE:

- 1) BAR MAT REINFORCEMENT, DOWELS AND TIE BARS NOT SHOWN
- 2) BAR MAT REINFORCEMENT, DOWELS AND TIE BARS TO BE 100mm TYP. FROM BUTT JOINT

NOTE

- 1) CURB AND GUTTER INLET TO BE ISOLATED MIN. 150mm FROM OUTSIDE DIAMETER OF CONCRETE RISER WITHIN APPROACH.
- 2) WHERE CURB & GUTTER INLET ALREADY EXISTS IN STREET, CONCRETE ISOLATION SHOULD BE REMOVED, RE-ISOLATED AND RE-POURED.

Reference Spec No. CW 3310
N.T.S.

Figure 24

**Curb and Gutter Replacement for Commercial and Residential Approaches;
Concrete/Paving Stone or Asphalt Streets with Barrier or Lip Curbs > 80mm**

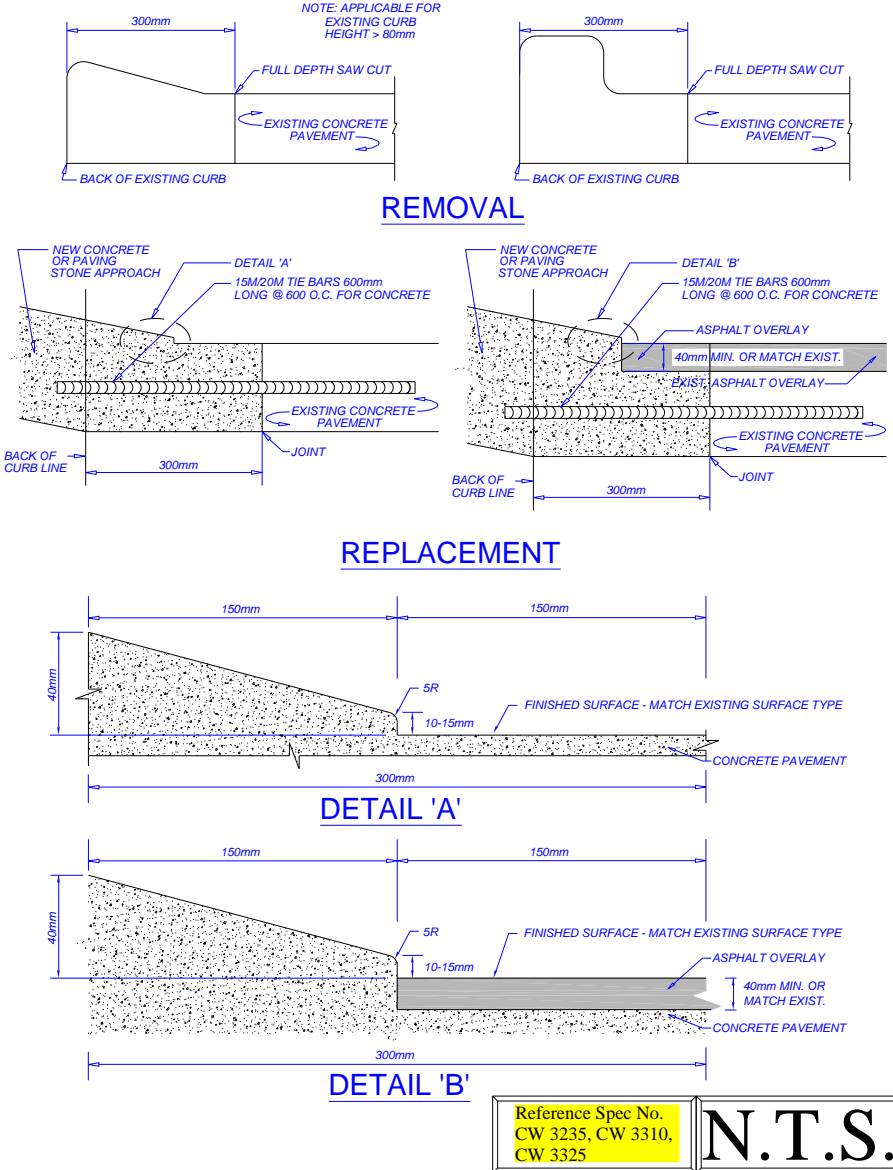
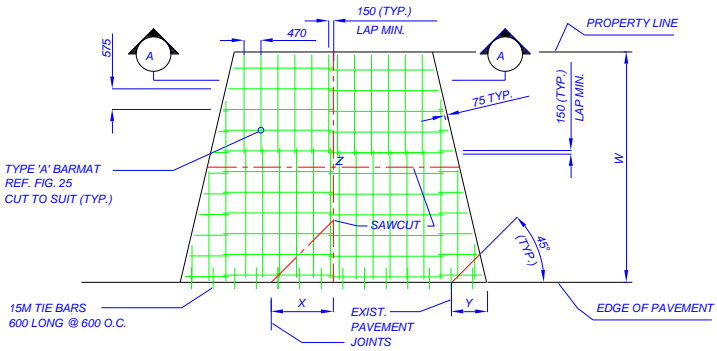
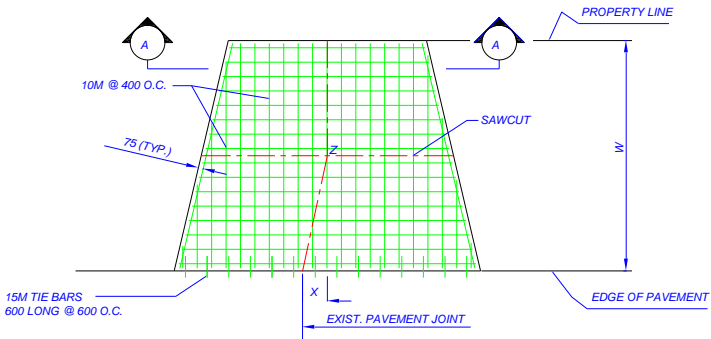

Figure 25

Residential Approach Reinforcing Steel Saw Cut Layouts and Bar Mat Layout for Approaches



ALTERNATIVE 1 - BAR MATS (12.7mm PLAIN)



ALTERNATIVE 2 - 10M (DEFORMED)

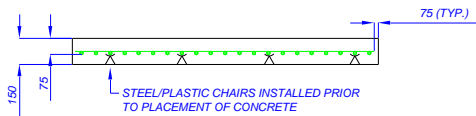

SECTION A-A

NOTE

- 1) DIMENSIONS ARE IN MILLIMETERS.
- 2) TRANSVERSE SAW CUT AT PAVEMENT JOINTS.
- 3) ALL SAW CUTS SHALL BE 50mm DEEP BY 3 mm WIDE SAW CUTTING LAYOUTS SHOWN ARE TWO POSSIBLE OPTIONS
IF "W" > 4300 ADD SAWCUT AT W/2, IF "X" < 1000 EXTEND SAWCUT TO POINT "Z", IF "Y" < 1000 NO SAWCUT REQUIRED

Reference Spec No. CW 3230, CW 3310
N.T.S.

Figure 26

Commercial Approach Saw Cut Layouts

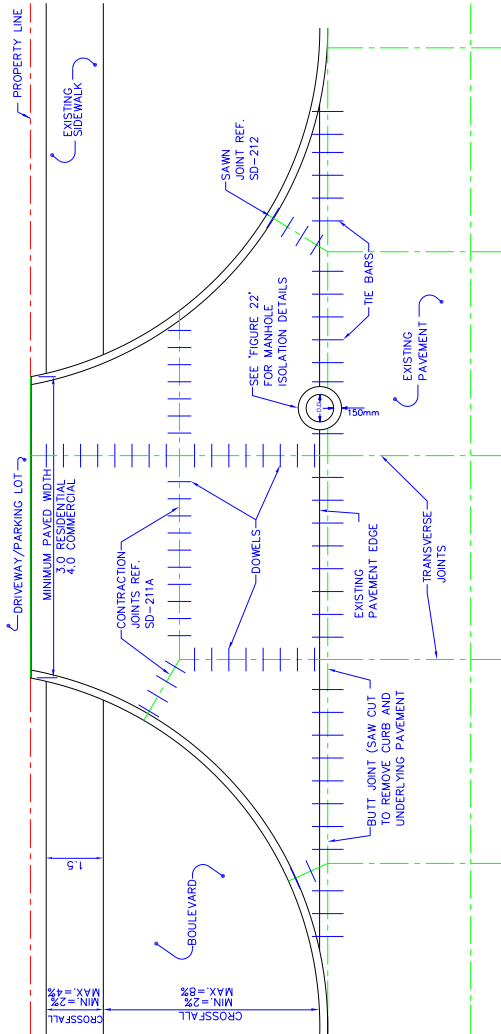

NOTE

- 1) WHERE NO SIDEWALK EXISTS, APPROACH SHALL BE CONSTRUCTED TO PROPERTY LINE.
- 2) EXISTING SIDEWALK SHALL BE REMOVED AND THE APPROACH AND EXPANSION JOINT EXTENDED BACK TO THE PROPERTY LINE AS SHOWN.
- 3) M.H. ISOLATIONS TO BE APPROVED BY CONTRACT ADMINISTRATOR.
- 4) CONTRACTION JOINTS AS REQUIRED TO MATCH STREET TRANSVERSE JOINTS.

Reference Spec No. CW 3230, CW 3310
N.T.S.

Figure 27

Commercial Approach Reinforcing Steel and Layout for Type 'A' and 'B' Bar Mat Reinforcement

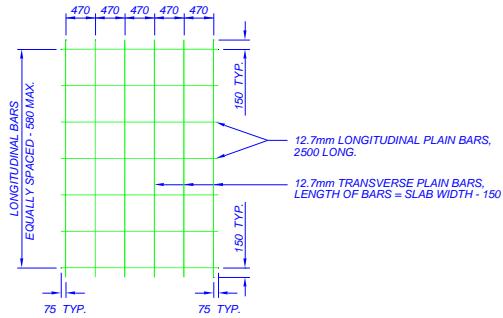

BAR MAT 'A' REINFORCEMENT

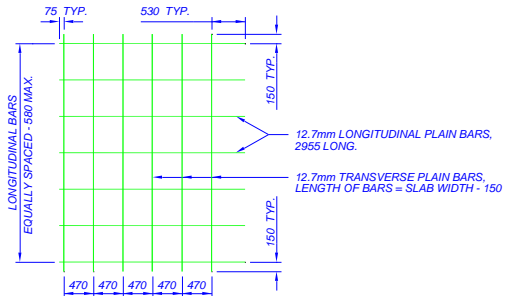

BAR MAT 'B' REINFORCEMENT

NOTE

- 1) ALL BAR MATS JOINTS TO BE ELECTRICALLY SPOT WELDED.
- 2) ALL DIMENSIONS ARE TO CENTRES OF BARS.
- 3) ALL DIMENSIONS ARE IN MILLIMETERS.

Reference Spec No. CW 3230, CW 3310
N.T.S.

Figure 28

Approaches Located Adjacent to Obstructions, Including but Not Limited to Fire Hydrants, Hydro Poles and Communication Pedestals

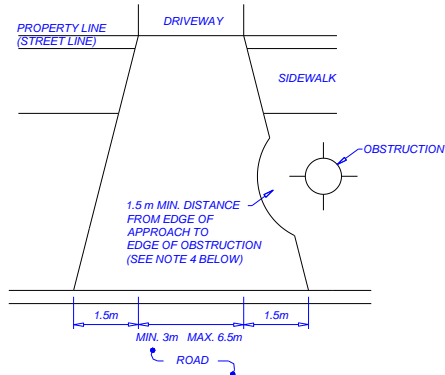

INCORRECT APPROACH CONSTRUCTION

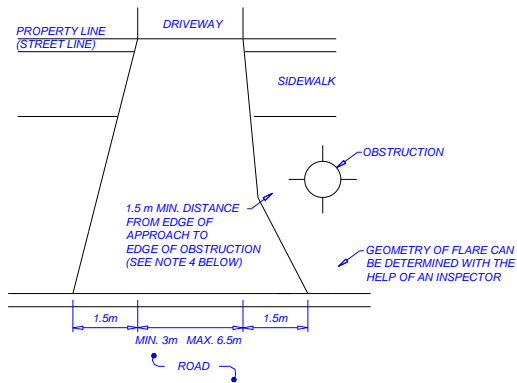

CORRECT APPROACH CONSTRUCTION

PLAN VIEW

NOTE

- 1) APPROACHES MUST BE CONSTRUCTED TO MAINTAIN THE MIN. 1.5m CLEARANCE
- 2) OBSTRUCTIONS INCLUDE, BUT NOT LIMITED TO:
LAMP STANDARDS, HYDRO POLES AND FIRE HYDRANTS
- 3) AREA INSPECTORS ARE AVAILABLE TO HELP WITH GEOMETRY OF APPROACH FLARES
- 4) CITY FORESTER APPROVAL IS REQUIRED IF A TREE IS WITHIN 2.0m OF THE EDGE OF AN APPROACH



Figure 29

Modified Barrier Curb for *Commercial* Concrete Approaches

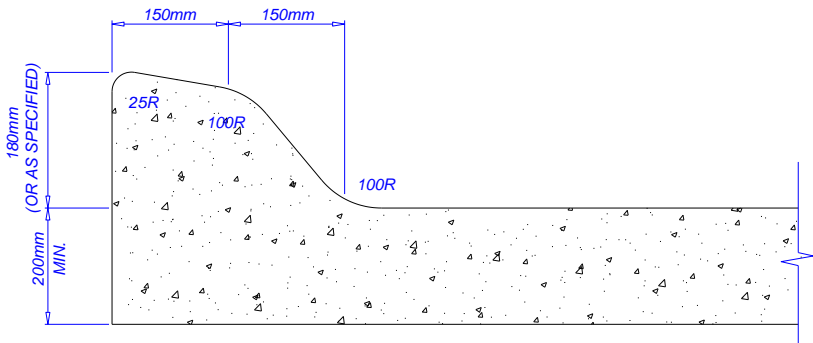

INTEGRAL MODIFIED BARRIER CURB

Reference Spec No. CW 3240, CW 3310
N.T.S.

Figure 30

Curb Ramp Detail for Commercial Concrete Approaches

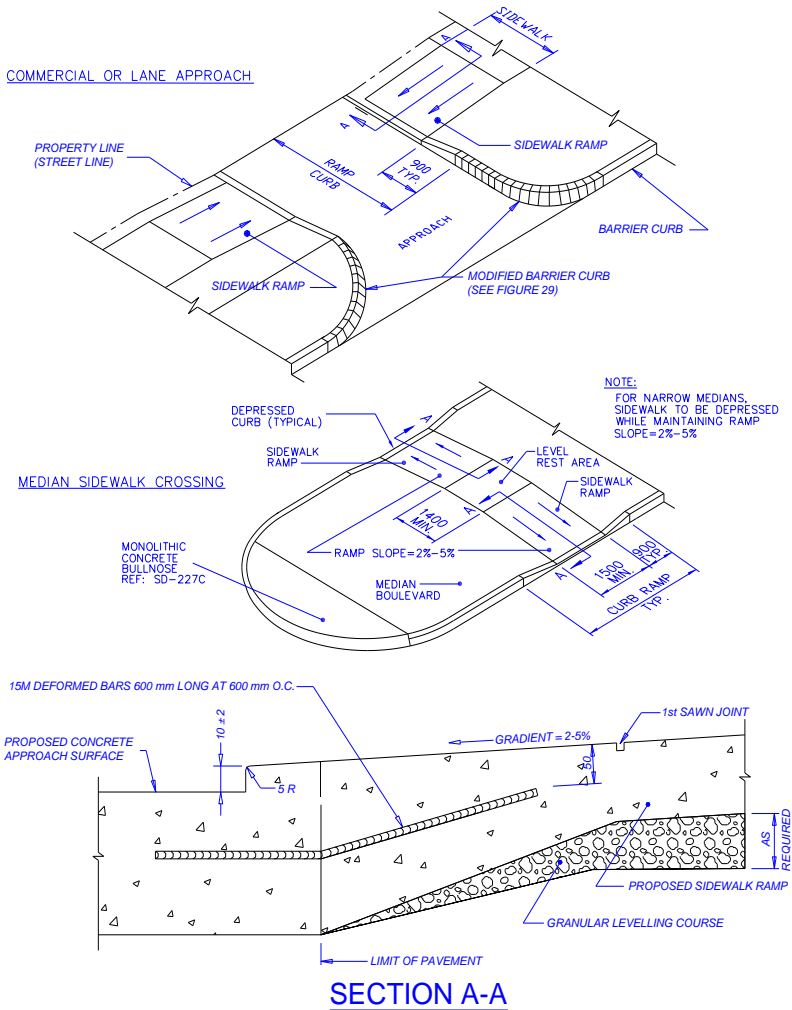

NOTE:
FOR NARROW MEDIANS,
SIDEWALK TO BE DEPRESSED
WHILE MAINTAINING RAMP
SLOPE = 2% - 5%

NOTE

- 1) SIDEWALK RAMP SURFACE SHALL BE GIVEN A TEXTURED BROOM FINISH ACROSS THE SIDEWALK
- 2) 15M TIE BARS SHALL BE PLACED PRIOR TO THE PLACING OF ANY CONCRETE. TIE BARS SHALL BE BENT AS REQUIRED AND PLACED SO AS TO ENSURE A MINIMUM CONCRETE COVER OF 50mm.
- 3) WHEN REPLACING THE CONNECTING SIDEWALK AT AN APPROACH, THE SIDEWALK MUST MAINTAIN A 5% GRADE OR LESS (EXTRA PANELS MAY NEED TO BE REMOVED)
- 4) ALL DIMENSIONS ARE IN MILLIMETERS.

Reference Spec No. CW 3235, CW 3310 CW 3325
N.T.S.

Figure 31

Curb Details for New Asphalt Pavements

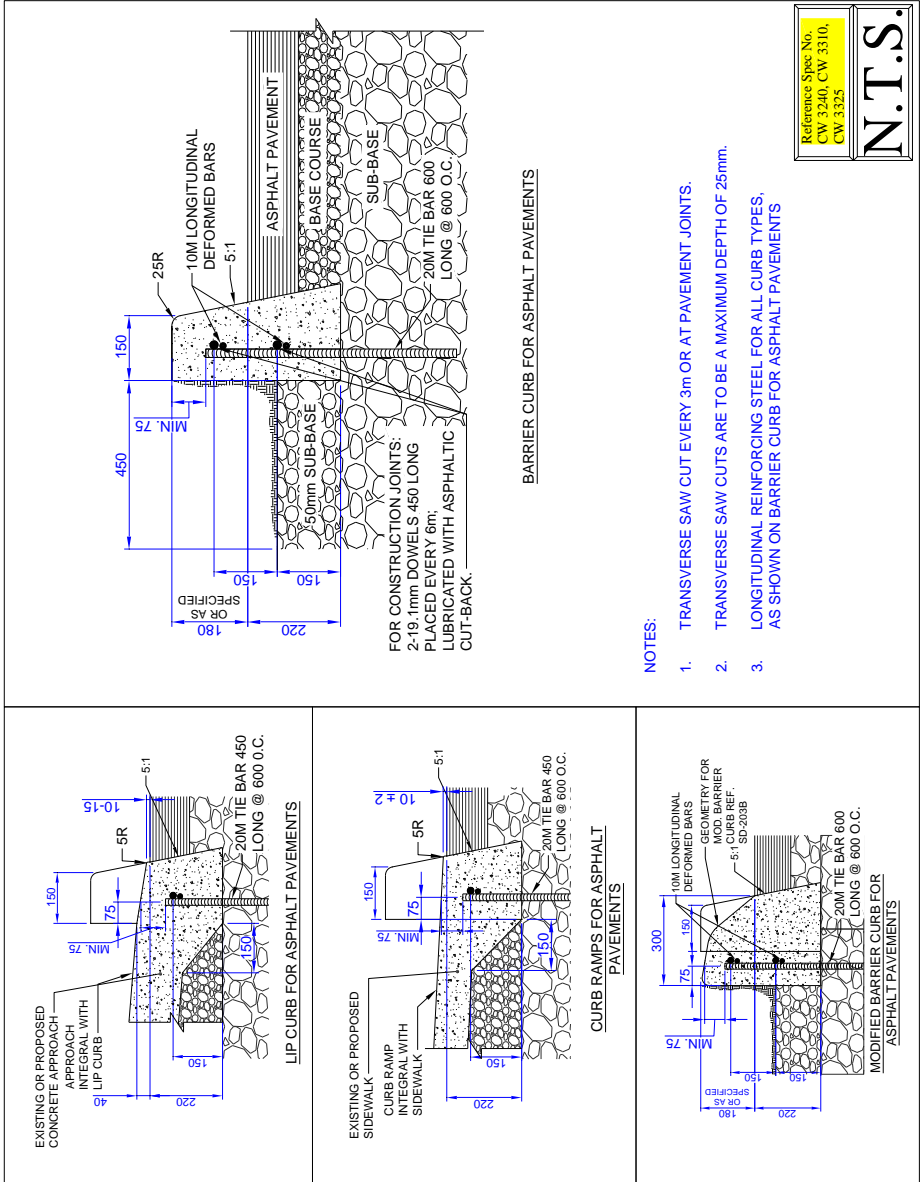

GENERAL INFORMATION

Approvals / Permits

Private approaches/walks are coordinated through one of two divisions of the Public Works Department.

For **approvals** of:

1. ALL COMMERCIAL / INDUSTRIAL Private Approaches/Walks
RESIDENTIAL FARM Private Approach/Walks on REGIONAL STREETS⁸
Contact : Private Approach Technologist
Email: PWDPPrivateAccess@winnipeg.ca
Traffic Assessment Branch
Transportation Division
Public Works Department
101-1155 Pacific Ave., Winnipeg, MB R3E 3P1
2. RESIDENTIAL / FARM Private Approaches/Walks on NON-REGIONAL STREETS⁸
Contact : Plan Approval/Permit Technologist
Phone: **204.986.4113**
Email: PWDPPermits@winnipeg.ca
Technology Services Branch
Engineering Division
Public Works Department
106-1155 Pacific Ave., Winnipeg, MB R3E 3P1

Always contact the applicable technologist when constructing, removing, relocating or modifying a private approach/walk. The technologist will determine if an approval/permit is required for the proposed works.

All Residential Permits are issued by the Plan Approval/Permit Technologist at 204.986.4113 or pwdpermits@winnipeg.ca. For all Commercial Permits, the applicant is responsible for contacting customer service at **204.986.3184** or pwdcspemits@winnipeg.ca to issue one after an approval has been obtained from the Transportation Division.

An approval/permit is always required to construct a new private approach/walk or for their reconstruction. When hiring a **LICENSED PRIVATE APPROACH CONTRACTOR**, you should verify that there is a valid approval/permit.

***NOTE:** Commercial approaches are dependent on property type as well and may be located on a Non-Regional street.

⁸ A map of Regional and Non-Regional streets can be found at the following link:
<https://legacy.winnipeg.ca/publicworks/trafficControl/pdf/regionalStreetNetwork-MAP.pdf>

Inspections

All inspections on Private Approaches/Walks are performed by the City of Winnipeg, Public Works Department, Engineering Division, Technology Services Branch by a designated employee.

TO ARRANGE FOR AN INSPECTION:

A.M RESIDENTIAL INSPECTIONS-Email prior to noon of the previous business day.

P.M. RESIDENTIAL INSPECTIONS-Email prior the end of the previous business day.

RESIDENTIAL AND COMMERCIAL APPROACH INSPECTIONS

Provide at least twenty-four (24) hours' notice to the Residential/Commercial Approach Inspector. The City of Winnipeg will no longer accept telephone calls for **Residential/ Commercial approach inspections** but rather an email to the **Residential/Commercial Approach Inspector** will be required (see '*INSPECTOR CONTACTS*' page 66).

Emails received on Fridays (or the last business day of the week in the event of holidays) will be accommodated on Mondays (or the first business day of the week in the event of holidays)

The Private Access Contractor must be the one to send an email request to the inspector for the specific area where the inspection is located, a map of the 'APPROACH INSPECTION BOUNDARIES' can be found on page 65.

Re-inspection Fee

Where an inspection takes place and the private approach cannot be approved by the designated employee because

- a.) the work is not at a stage where an inspection of the work can take place; or
- b.) the work has not been carried out in compliance with the By-law;

An inspection fee of \$30.00 is payable by the **LICENSED CONTRACTOR** to the City.

Median Modifications, Loading Bays and Turning Lanes

If there is a median modification, loading bay or turning lane on the **Commercial Approach Approval**, it is the applicant's responsibility to retain the services of a professional Engineer Consultant in road construction, acceptable to the Director of Public Works, to oversee the construction and inspection as our inspectors do not provide inspections for these.

A final report will need to be submitted to The Public Works' Department at **pwdPA-DDInspector@winnipeg.ca** and as-built drawings are to be submitted to Underground Structures at **ugsapproval@winnipeg.ca**. The Development Agreement's 'Terms and Conditions' that will be attached to the approval obtained from Transportation, are to be followed. (Contact info for *Commercial Approach approvals* is under '**Approvals / Permits**', page 61)

Cold Weather Concreting (Clause 6.12.3 of Specification CW3310)

When there is a probability of the air temperature falling below 5°C within 24 hours of placing concrete as forecast by the nearest official meteorological office, Cold Weather concreting requirements shall apply unless otherwise specified by the City of Winnipeg, Research and Standards Engineer. In no case shall placing concrete be allowed if the minimum air temperature is below -8°C within 24 hours of placing concrete or the average daily temperature for three consecutive days is expected to fall below -10°C as forecast by the nearest official meteorological office.

The Contractor shall maintain the internal concrete temperature above 10°C for a minimum of five (5) days after completion of placing operations, and until the concrete has developed a minimum compressive strength of 24 MPa. The protection method(s) may be removed after three (3) days where the concrete has achieved its design strength (35 MPa). Temperature and concrete compressive strength shall be determined by maturity meters and field cured cylinders.

The Contractor shall be responsible for the methods of protecting the concrete from Cold Weather such as insulation (blankets and boards), heating systems such as electric blankets and hydronic heating systems, unheated or heated enclosures, or a combination of the methods to maintain the internal concrete temperature above 10°C. In no case shall the protection method be less than a combination of one layer of polyethylene film and one layer of insulated tarp with R-value of 0.5.

The recommended protection method using an insulated tarp(s) is show in Table CW3310.7.

Table CW 3310.7: Minimum Thermal Resistance Values for Insulated Tarp				
Slab thickness (mm)	The Low Temperature within 24h of Placing or Average Low Ambient Air Temperature within three (3) days of Placing			
	R=1	R=2	R=3	R=4
<150 mm	↓	↓	5 > T ≥ 0	0 > T ≥ -5
150 mm – 200 mm	↓	5 > T ≥ 3	3 > T ≥ 0	0 > T ≥ -8
>200 mm	5 > T ≥ 3	3 > T ≥ 0	0 > T ≥ 3	-3 > T ≥ -8

All construction methods under Clause 6.12.3 of Specification CW3310 shall be followed for Cold Weather Concrete. Concrete damaged as a result of inadequate protection against weather conditions shall be removed and replaced by the Contractor at his own expense.

For temperatures below 5°C – a plan of heating and hoarding the base prior to pour, as well as the concrete during curing and protection methods shall be submitted to the Senior Technologist for approval before commencement of work. (See 'INSPECTOR CONTACTS' on page 66 for Senior Technologist).

Approach Culverts: Diameter, Length & Elevations & Materials

- **Culvert diameter** to be determined by the City of Winnipeg, Water & Waste Department, Engineering Division, Land Drainage and Flood Protection Technologist at 204.986.3670 or CNault@winnipeg.ca
- Contractor to calculate **culvert length** based on approved approach width, approach shoulder widths and a minimum 4:1 (rise over run) ditch slope.
- For **culvert elevations** email pwdPA-DDInspector@winnipeg.ca at least five (5) working days prior to the work commencing.

Culvert End Markers⁶

(Reference Spec No. CW3610)

Supply culvert end markers in accordance with the following:

- 3.) Culvert end markers shall be 1500 ± 100mm in height.
- 4.) Culvert end markers shall be HDPE, SDR 9.3, 30mm (1¼") in diameter, bright orange in colour with an adhesive backed reflective strip placed around the marker. The reflective strip shall be placed within 25mm of the top of the marker.

Manhole & Catch Basin Adjustment (Reference Spec No. CW 3210 & CW 2130)

The Private Access By-law No. 49/2008, Section 22 requires all manhole adjustments necessary for the construction of new private approaches in new subdivision be the full responsibility of the property owner. Any adjustments that are required to the structure of the manhole i.e. concrete risers; pipe and barrel repairs shall be completed by a licensed sewer and water contractor. Manholes/catch basins are to be isolated as outlined on **Figure 22& Figure 23**. (See **page 67**, '**LINKS**' - Licensed Sewer/Water Contractors) The installation of cast iron lifter rings or installation of levelling bricks may be performed by an experienced licensed approach contractor. All works must be performed to the City of Winnipeg Standard Construction Specifications and must be inspected prior to pouring of the concrete approach, and re-inspected when completed.

If a manhole/catch basin is present, please email the Area Approach Inspector and Junior Technologist prior to excavating for the approach. (See 'INSPECTOR CONTACTS': **page 66**)

APPROACH INSPECTION BOUNDARIES

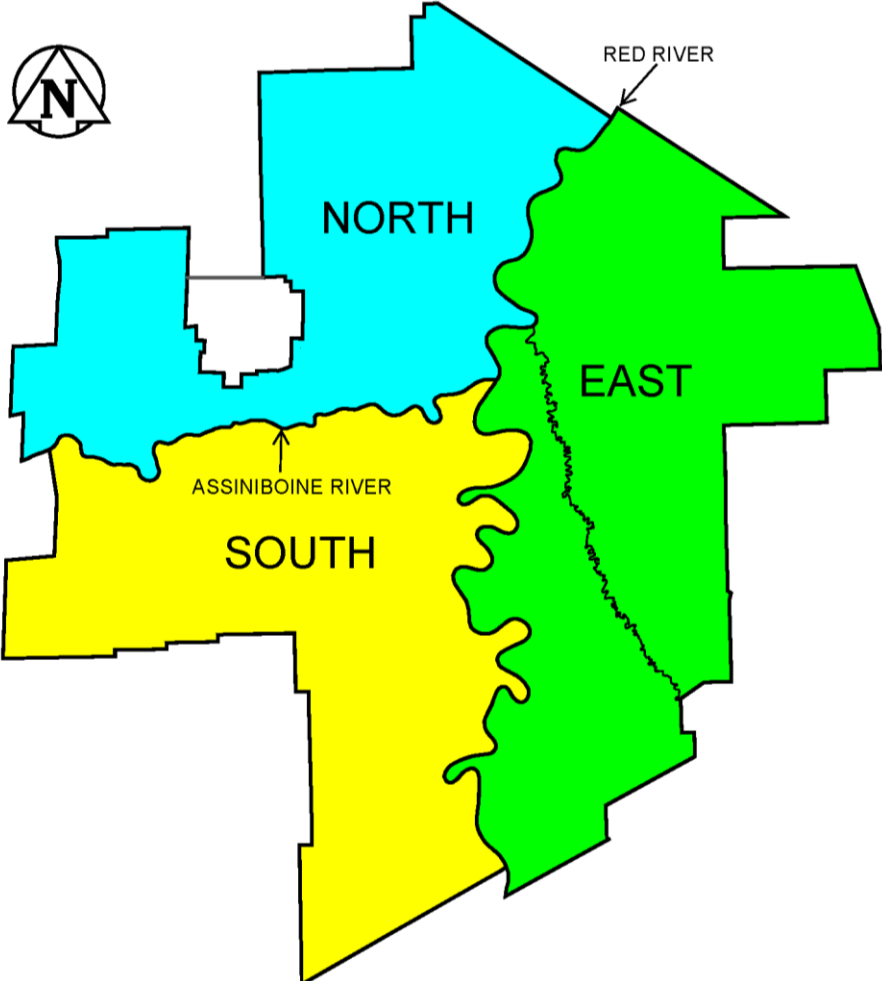

INSPECTOR CONTACTS

Contact	Contact Information
Supervisor of Right-of-Way Management	204.794.4354 OTarasov@winnipeg.ca
Senior Technologist (Licensing & Compliance, Inspections)	204.794.4060 CTimbreza@winnipeg.ca
Junior Technologist (Approach Inquiries, Inspections)	431.293.0769 GMcPherson@winnipeg.ca
North Area Residential Approach Inspector*	pwapproachN@winnipeg.ca
South Area Residential Approach Inspector*	pwapproachS@winnipeg.ca
East Area Residential Approach Inspector*	pwapproachE@winnipeg.ca
Commercial Approach Inspector	CTimbreza@winnipeg.ca
General Inquiries, Culvert Elevations, Manhole & Catch Basin Adjustments	pwdPA-DDInspector@winnipeg.ca

***The Residential Approach Inspectors' email addresses are only active during the construction season (approximately May to October, weather dependent)**

OTHER CONTACTS

Plan Approval/ Permit Technologist

(Residential on Non- Regional Streets Permits/Approvals)

PWDpermits@winnipeg.ca or 204.986.4113

Private Approach Technologist (All Commercial & Residential on Regional Streets Approvals)

PWDPrivateAccess@Winnipeg.ca

Customer Services Branch (Payments and Commercial Permits)

PWDcspemits@winnipeg.ca or 204.986.3184

For **Culvert Diameter** contact (Water & Waste Department, Engineering Division, Land Drainage & Flood Protection Technologist)

CNault@winnipeg.ca or 204.986.3670

For Development Permit or Variance

PPD-
zoningapplications@winnipeg.ca
or 204.986.5140

Traffic Management Branch

PWDLaneClosures@winnipeg.ca
or 204.986.5640

City Forester

KAsmundson@winnipeg.ca

LINKS

- List of City of Winnipeg's **Licensed Private Access Contractors** available: https://legacy.winnipeg.ca/publicworks/permitsApprovals/pdf/approaches/list_lic_appr_contractors.pdf
- List of City of Winnipeg's **Licensed Sewer/Water Contractors**: [Licensed Sewer and Water Contractors - Water and Waste - City of Winnipeg](https://legacy.winnipeg.ca/publicworks/permitsApprovals/pdf/approaches/list_lic_appr_contractors.pdf)
- The City of Winnipeg's **Private Access By-Law No. 49/2008**; available: <https://clkapps.winnipeg.ca/DMIS/docext/ViewDoc.asp?DocumentTypeld=1&DocId=4136>
- The City of Winnipeg's **Streets By-Law No. 1481/77**; available: <https://clkapps.winnipeg.ca/DMIS/docext/ViewDoc.asp?DocumentTypeld=1&DocId=304>
- The City of Winnipeg's **Manual of Temporary Traffic Control on City Streets**; available: <https://legacy.winnipeg.ca/publicworks/trafficControl/manual-temporary-traffic-control.stm>
- The City of Winnipeg's **Standard Construction Specifications**: <https://legacy.winnipeg.ca/matmgt/Spec/Default.stm>
- Relocation of Hydro Poles, Light Standards: https://www.hydro.mb.ca/accounts_and_services/services_and_lighting
- Approved Product Suppliers: https://legacy.winnipeg.ca/finance/findata/matmgt/std_const_spec/current/Docs/Approved_Product_Suppliers.pdf
- Approved Concrete Suppliers: https://legacy.winnipeg.ca/finance/findata/matmgt/std_const_spec/current/Docs/Approved_concrete_suppliers.pdf
- Snap Edge Canada Ltd.: [Snapedge Paving Stone Edging | Barrier Edging | Hardscape Products | Home](https://www.snapedge.ca/)

NOTES



Winnipeg

Public Works
Travaux publics