

The Problem:

It is a popular belief that wind damage to mobile homes is associated only with hurricanes and tornadoes, and that because these types of storms are not common in Canada there is no need to worry. This is not correct. Wind speeds capable of destroying mobile homes can and do occur in every part of Canada. Gusts in thunderstorms, for example, often produce winds sufficient to push an unanchored mobile home off its blocks and roll it over. This can result in the complete destruction of the unit and, frequently, injury to its occupants rather than the minor damage usually experienced in ordinary houses.

For a typical mobile home or trailer, it can be shown that an unanchored mobile home can only withstand 70 to 80 km/h winds (45 to 50 mph) without overturning. This is considerably less than the design gust speeds for the Winnipeg Area.

Protection against wind forces can be achieved by anchoring the mobile home or trailer into the ground along both longitudinal walls.

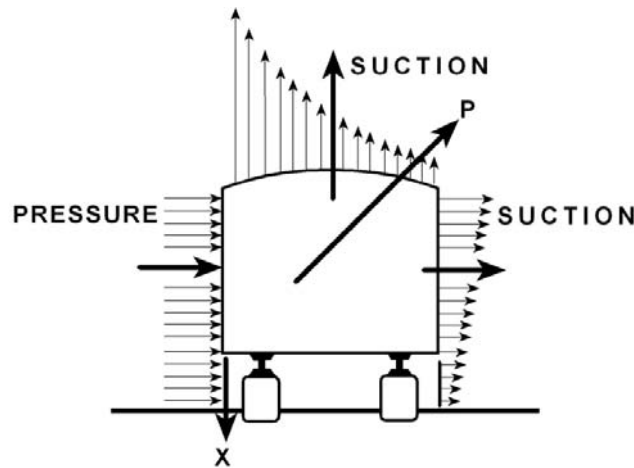

Who can design wind anchorage?

Before the Plan Examination Branch can clear a building permit to locate a mobile home or trailer either temporarily or permanently within the City of Winnipeg**, the applicant must provide a drawing under the seal of a Professional Engineer licensed to practice in the Province of Manitoba. The drawing must provide all the information necessary to evaluate the design. (The Plan Examination Branch is not permitted to design the wind anchorage. This is the responsibility of the Professional Engineer).

How do I go about retaining the services of a Professional Engineer?

In some cases, trailer manufacturers may be able to supply a wind anchorage detail that is already sealed by a Professional Engineer and has been pre-approved by the Plan Examination Branch. If such a drawing is not available, we suggest looking under "Engineers" in the yellow pages of the phone book. Any of the engineers listed under "Structural" can provide the drawing required.

****NOTE:**

Mobile homes located in mobile home parks are regulated by the owners of the mobile home park and do not require building permits.

NOTE:

This bulletin applies only to wind anchorage. There are other By-law requirements that can apply to a mobile home or trailer.

In-Person Customer Service Hours are:
Tuesday to Friday 8:30 am to 4:30 pm - All Zoning, Permits and Plan Examination services are available at Unit 31 – 30 Fort Street.

Mondays 8:30 am to 4:30 pm are reserved for telephone inquiries and completed application drop-offs. This enables Zoning and Permits staff to process building and development applications received throughout the week.

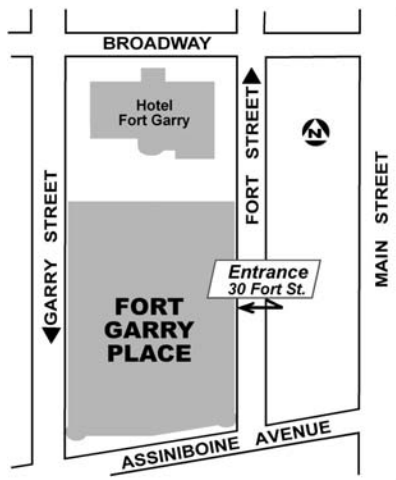

Every effort has been made to ensure the accuracy of information contained in this booklet. However, in the event of a discrepancy between this booklet and the governing City of Winnipeg By-law, the By-law will take precedence.



For more information on this bulletin or building requirements that may pertain to mobile homes and trailers, please contact:

Plan Examination Branch
PH: 204-986-5268
FAX: 204-986-7307

or



Winnipeg
at your service.

City of Winnipeg
Planning, Property and Development Department
31 - 30 Fort Street
Winnipeg, Manitoba
R3C 4X7

www.winnipeg.ca/ppd

February 2001



Trailer Wind Anchorage

A general guideline on the wind anchorage requirements for mobile homes and trailers

