



PLANNING, PROPERTY
AND DEVELOPMENT
DEPARTMENT

Plumbing Installations

*A homeowner guide to the City of
Winnipeg plumbing requirements
for a single-family dwelling*



January 2008

General Information _____	3
Inspection _____	4
New Drain and Vent Installations _____	5
Potable Water Systems _____	15
Protection From Contamination	
By Cross Connections _____	16

note

This booklet has been written to:

- 1) Provide homeowners with a summary of some more common plumbing regulations; and
- 2) Provide information on the extent to which the plumbing work must be completed before requesting an inspection.

It is recommended that the applicable sections of this booklet be reviewed before commencing the project. Please note that this booklet is **not** intended to cover all of the plumbing regulations. Complete plumbing requirements are covered in the Manitoba Plumbing Code.

Every effort has been made to ensure the accuracy of information contained in this booklet. However, in case of a discrepancy between this booklet and the governing City of Winnipeg By-law, the By-law will take precedence.

When is a plumbing permit required?

A plumbing permit must be obtained from the City of Winnipeg Planning, Property and Development Department, Unit 31 - 30 Fort Street whenever:

- a) a plumbing system is constructed, extended, altered, renewed or repaired, and
- b) when water supply lines in a building are replaced.

NOTE: *Lead free solder is required for all water supply lines.*

When is a plumbing permit not required?

A plumbing permit is not required when:

- a) a stoppage in the drainage system is cleared;
- b) a leak is repaired in a water distribution system;
- c) a fixture is replaced without any change to the drainage system; or
- d) a replacement is made to existing faucets, or service water heaters.

Who may obtain a plumbing permit?

Plumbing permits can be issued only to:

- a) a person who holds a Plumbing Contractor’s license from the City of Winnipeg authorizing that person to carry out business or trade in the City of Winnipeg; **OR**
- b) the owner of a detached single family dwelling who is also the **occupant**. The owner **personally** must do the work. The permit would be issued to the owner provided the Manager of Building Inspections is confident the work will be done competently.

Can a plumbing permit be transferred to an individual other than the original applicant?

No! A plumbing permit is not transferable.

What information is required to apply for a plumbing permit?

To obtain a plumbing permit, the homeowner must present a plumbing diagram for the proposed installation with the following details:

- a) the diagram must have a view from the side;
- b) be drawn as single line;
- c) show the drain and vent pipe sizes;
- d) show the location of each fixture.

An example of a typical plumbing diagram is shown is FIGURE 1.

FIGURE 1 - Typical Basement Plumbing Diagram

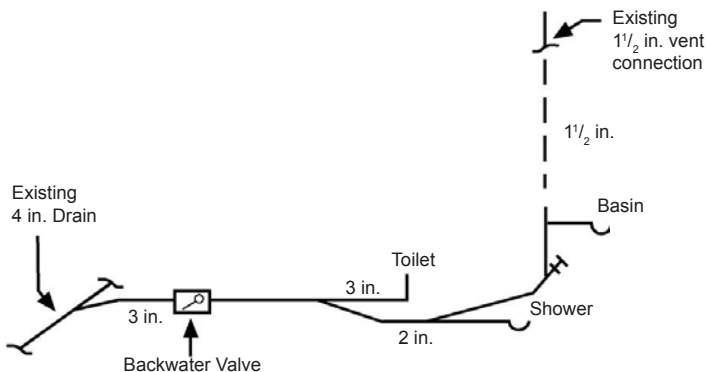

inspection

What must be ready for the first inspection?

Before calling the plumbing inspector, all drains and vents should be completed. The work **must not** be covered before inspection.

If any part of the plumbing work is found deficient during inspection, alterations or replacement must be made as necessary. The work may be subject to additional inspections.

Please call the inspector the morning of the day that the inspection is required. The inspectors office hours are between 8:30 a.m. and 9:30 a.m. weekdays. These are the only times that the inspector can be contacted to arrange an inspection.

What must be ready for the final inspection?

Before the final inspection, all fixtures and equipment must be installed and ready for use. If a fixture has been roughed-in for future use, the outlet must be sealed with an approved plug or cap.

Upon completion please contact the plumbing inspector for a final inspection.

What is the minimum slope requirement for drains?

All drains must be installed to provide a minimum slope away from the fixture of at least 6 mm (1/4 in.) for every 300 mm (1ft) of pipe length. The drains must be supported by a firm base/hanger to remain in that position. See FIGURE 2.

What is the total fall allowed from a fixture trap to the vent?

Except for a water closet, the total fall from the fixture trap to the vent must not exceed the diameter of the fixture drain. See FIGURE 3.

What is the maximum distance allowed between a vent pipe and a fixture trap or a water closet?

The maximum distance between a vent pipe and a fixture trap must not exceed the distances shown in TABLE 1. See FIGURE 4.

FIGURE 2 - Minimum Slope of Drains

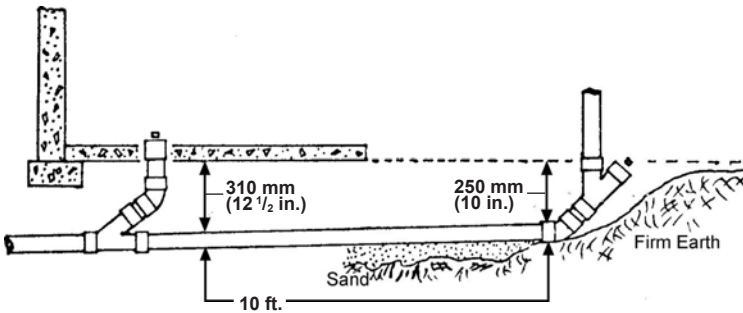

Drain sloped at 6 mm (1/4 in.) for every 300 mm (1 foot)

FIGURE 3 - Fall of Fixture Trap

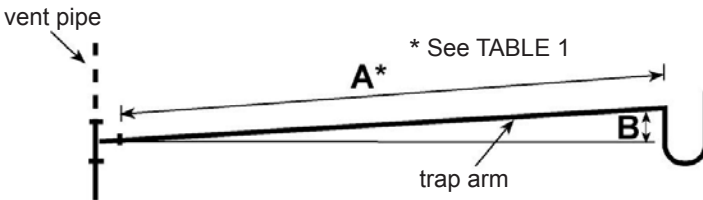

Developed length "A" must be at least twice the size of the trap arm. Fall "B" must not be greater than the size of the trap arm.

Are expansion fittings required for piping systems?

Yes! The design and installation of every piping system must, where necessary, include means to accommodate expansion and contraction of the piping system caused by temperature change. Therefore, where plastic pipe is used, expansion joints must be installed at the base of every soil or waste stack. See FIGURE 4.

TABLE 1 - Vent Connections

Pipe Size (in.)	Minimum Grade	Total Allowable Distance
1 1/4	1/50	1.5 m (5 ft.)
1 1/2	1/50	1.8 m (6 ft.)
2	1/50	2.4 m (8 ft.)
3	1/50	3.6 m (12 ft.)

FIGURE 4 - Lengths of Fixture Drains and Expansion Fitting

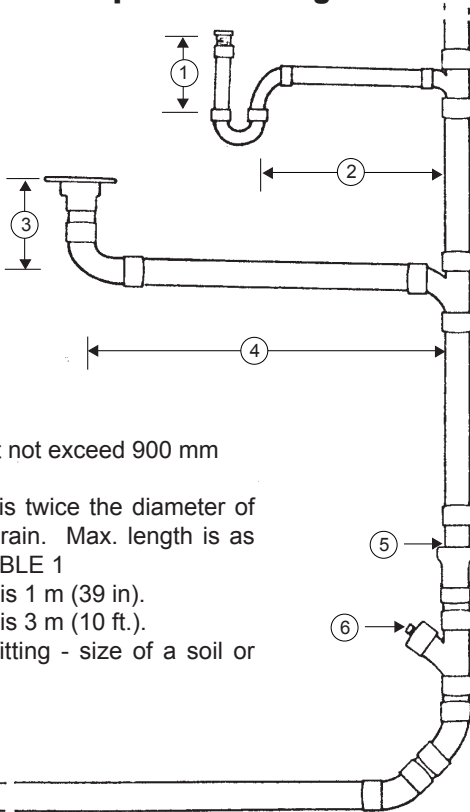

1. Length must not exceed 900 mm (35 in.)
2. Min. length is twice the diameter of the fixture drain. Max. length is as shown in TABLE 1
3. Max. length is 1 m (39 in.)
4. Max. length is 3 m (10 ft.)
5. Expansion fitting - size of a soil or waste stack.
6. Cleanout.

What are the locations of the cleanout fittings in the drainage system?

Approved cleanout fittings must be installed at the following locations:

- a) as close as practicable to the point where the building drain leaves the building;
- b) at the base of every soil or waste stack;
- c) to permit the cleaning of vents to the flood level rim of kitchen sinks; and
- d) at every 90 degree change of direction in sink wastes.

See FIGURE 5.

What are the requirements for the installation of "T" and "Y" fittings in the drainage system?

Tee fittings or 90 degree elbows must not be used in the horizontal portion of a drainage system. All changes of direction must be made with the use of Y's and 45 degree bends. Except that a 90-degree elbow or tee fittings may be used to change the direction of horizontal drains when the direction of flow is down to the vertical. Tee fittings may be used to make the connections to vent pipes. See FIGURE 6 and FIGURE 7. (Exceptions see FIGURE 8).

FIGURE 5 - Building Drainage System With Cleanout Fittings

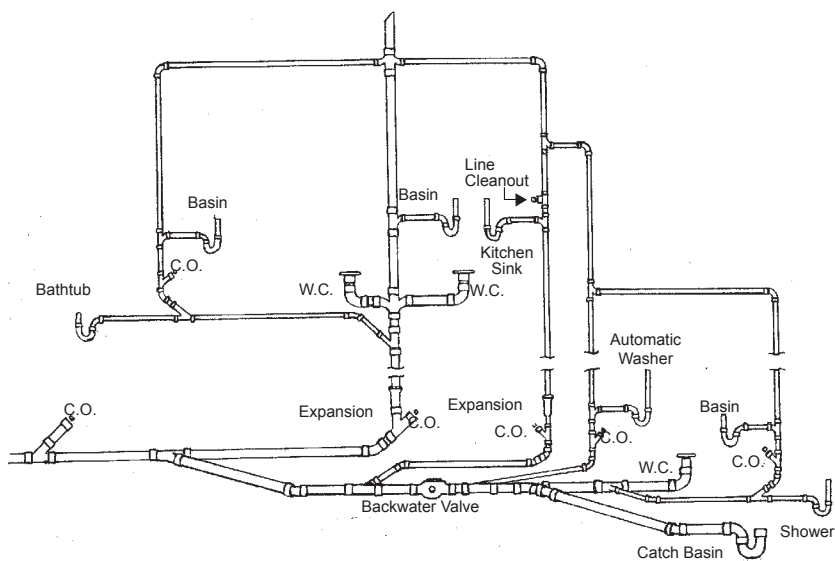

FIGURE 6 - Permitted Use of Sanitary "T" ("TY") Fittings - Part 1

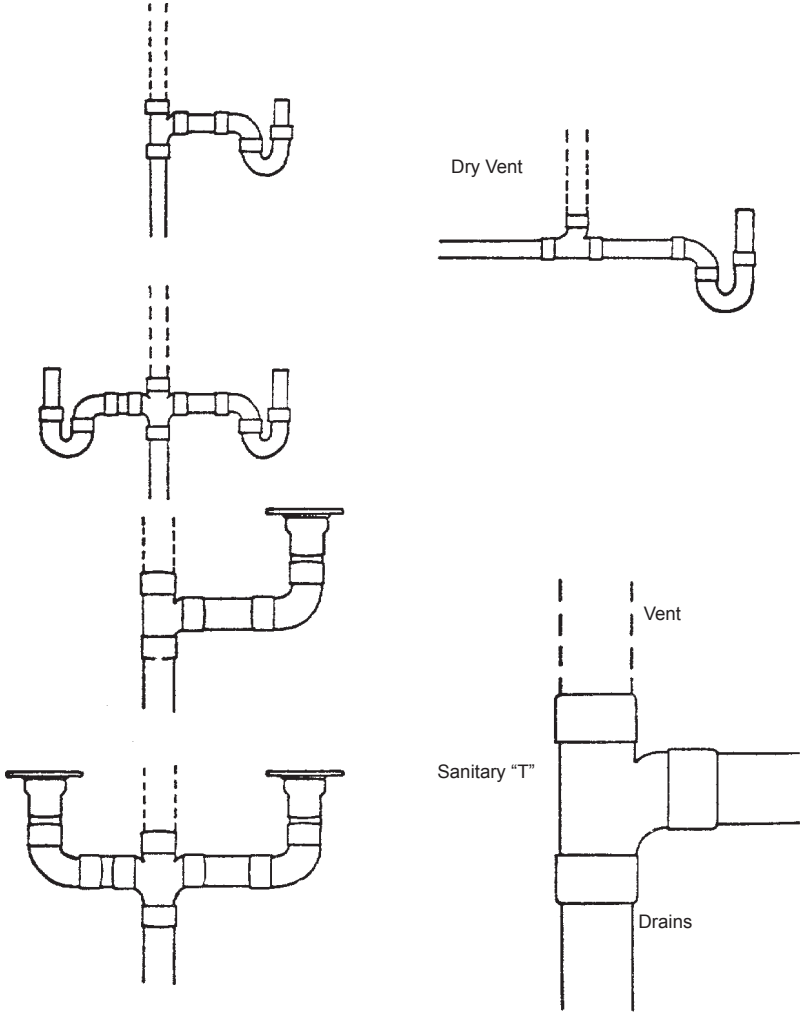

FIGURE 7 - Permitted Use of Sanitary "T" ("TY") Fittings - Part 2

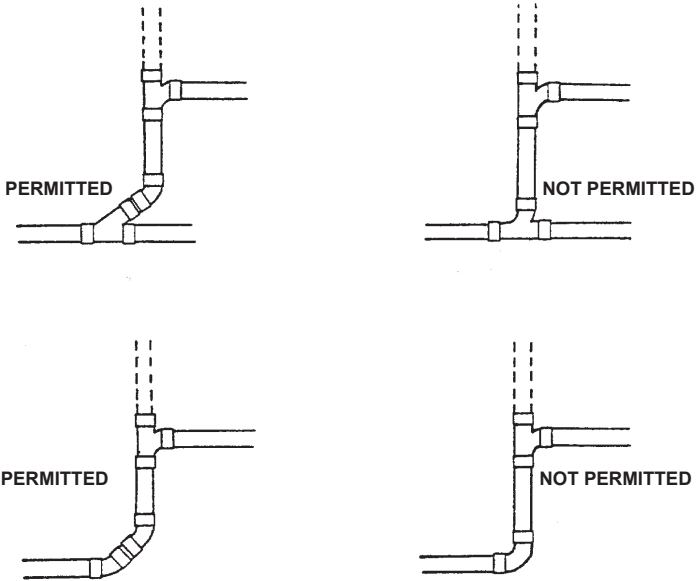
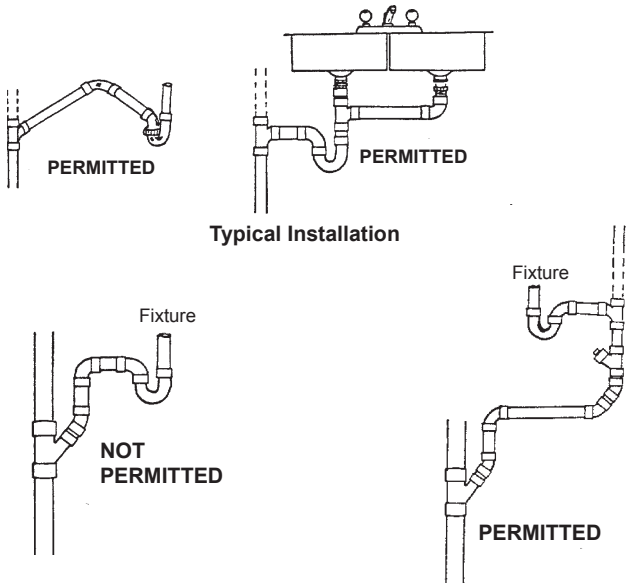

FIGURE 8 - Permitted Use of Sanitary "T" ("TY") Fittings - Exceptions



Can drainage or water piping be installed in exterior walls?

Where piping may be exposed to freezing conditions, it must be protected. No drainage or water system can be installed in any exterior wall of a building. Vent pipes are permitted in exterior walls.

Is room ventilation for bathrooms required?

Yes! Ventilation of bathrooms or any rooms containing a water closet must be provided by a mechanical exhaust system (fan) to the outdoors with a minimum rating of 50 c.f.m.

What requirements must be met for single storey wet venting of multiple fixtures?

A soil or waste pipe extended as a stack vent or a continuous vent may serve as a single storey wet vent if:

- a) all fixtures served by the vent are in the same storey;
- b) no soil-or-waste stack is connected upstream of a wet vented fixture;
- c) water closets are connected downstream of all other fixtures, and
- d) the fixture drains are connected separately and directly into the soil or waste pipe.

See FIGURES 9, 10 & 11.

FIGURE 9 - One Storey Venting (Back to Back)

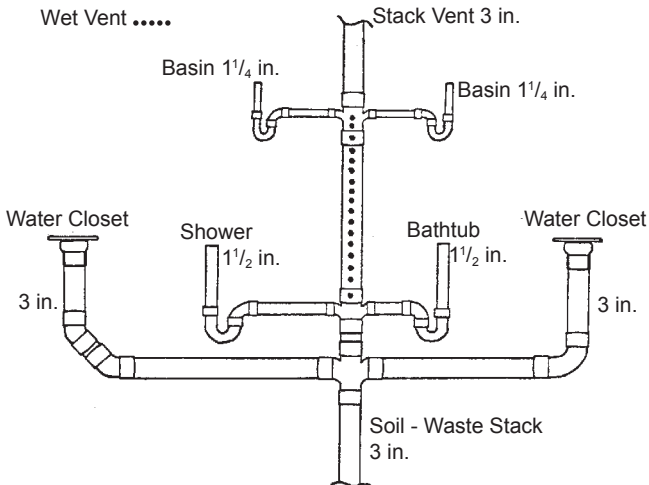
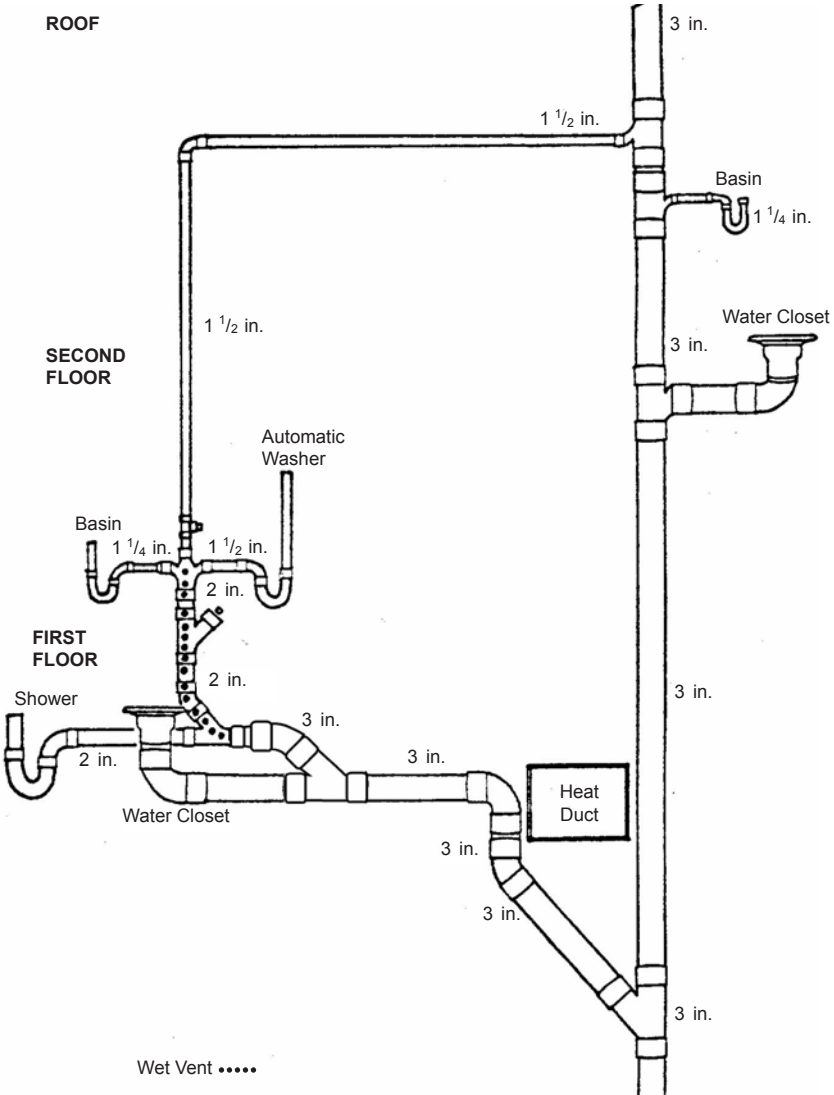

FIGURE 10 - Two Storey Venting



When is a backwater valve required?

All fixtures installed below street level must be protected by a backwater valve arranged to prevent sewer back-up. The backwater valve must be installed to protect the branch drain. A backwater valve may be installed on a building drain or building sewer if listed for that location. See FIGURE 5 and FIGURE 11. A sump pit should be installed with the back-water valve.

FIGURE 11 - Typical Basement Plumbing Installation Showing Venting Method, Backwater Valve & Attachment to "Cast-Iron" Piping

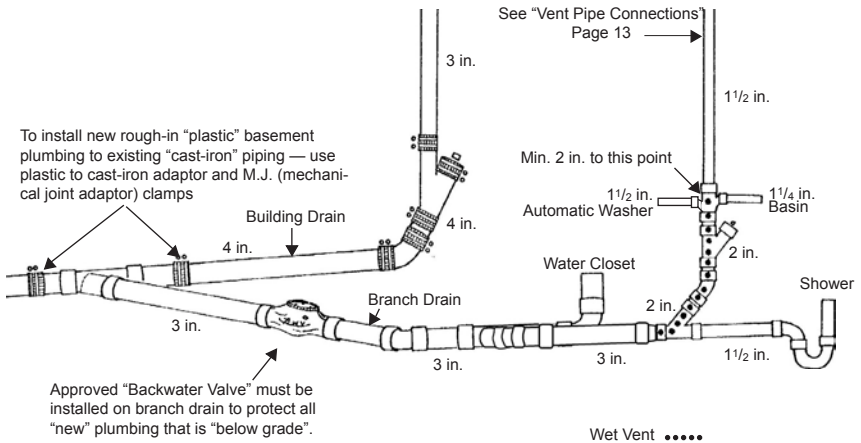
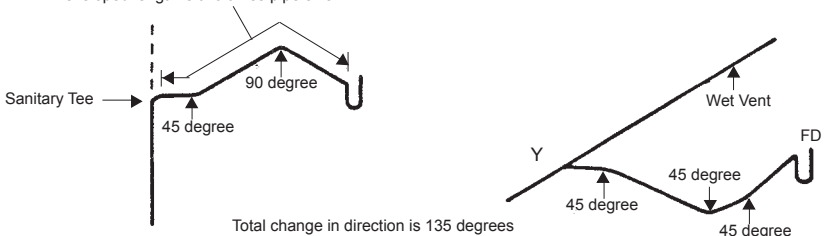

FIGURE 12 - Location of Vent Pipes Cumulative Change in Direction

Max. fall of trap arm is equal to pipe size
 Max. developed length must not exceed distances shown in TABLE 1
 Min. Developed length is two times pipe size



What is the maximum cumulative change in direction permitted between a fixture trap and a vent?

The cumulative change of direction between a fixture trap and a vent must not exceed 135 degrees. See FIGURE 12.

What are some requirements to be met when vent pipes are being connected and being run through the dwelling to the roof?

- a) Where a vent pipe passes through the roof, it must be protected from frost closure by increasing the pipe size to at least 75 mm (3 in.) in diameter immediately before penetrating the roof.
- b) A vent located in attic spaces must be insulated.
- c) Vent pipes must be installed without depressions in which moisture can collect.
- d) A vent pipe must extend vertically above the flood level rim of every fixture that it serves before being connected to another vent pipe.

See FIGURE 13.

FIGURE 13 - Vent Pipe Connections

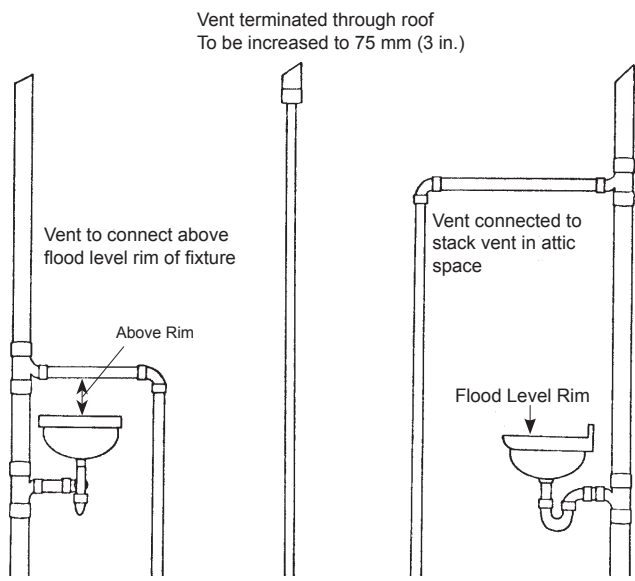
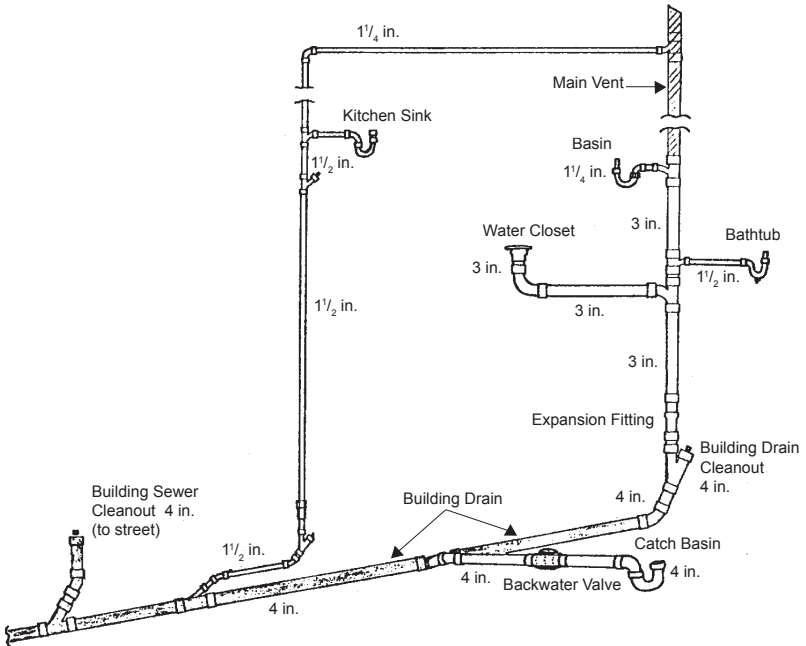

TABLE 2 - Fixture Size Requirements

FIXTURE	MIN. SIZE OF FIXTURE OUTLET PIPES (inches)
Bathtub (with or without shower)	1½
Bidet	1¼
Clothes Washer	1½
Dishwashers (no load when connected to a garbage disposal unit or a kitchen sink trap)	1½
Garbage disposal units - residential type	1½
Laundry sinks	1½
Lavatories (basin)	1¼
Shower Drain	1½
Sink - one and two compartments with garbage disposal unit	1½
Water Closet	3

FIGURE 14 - Typical Drainage & Vent Sizing



NOTE: Every building drain must be at least 100 mm. (4 in) in size and must be terminated by a vent at least 75 mm (3 in.) in size.

What are the size requirements for fixture outlet pipes?

The sizes of all fixture outlet pipes must comply with TABLE 2. See FIGURE 14.

What are the requirements that must be met for the installation of a potable water system?

All potable water systems must meet the following standards.

- a) Every water service pipe must be provided with a shut-off valve where the pipe enters the building.
- b) A water distribution system must be installed so that the system can be drained or blown out with air
- c) Every fixture supplied with hot and cold water controls must have the hot water control on the left and the cold water control on the right.
- d) Every water closet must be provided with a shut-off valve on the water supply pipe.
- e) Every pipe that passes through an exterior wall to supply water (i.e., lawn service) must be provided with a frost-proof hydrant or a stop-and-waste valve placed inside the building close to the outside wall or other approved location. Also, a hose bib vacuum breaker must be installed on a hose bib located outside a building or inside a garage to protect against backflow.
- f) Every hot water tank must be provided with a shut-off valve and a pressure and temperature relief valve. The pressure and temperature relief valve must be designed to open when the water pressure in the tank exceeds the rated working pressure of the tank or when the water temperature exceeds 99°C (210°F). Every temperature and pressure relief valve must be provided with a drain and the drain must extend to within 300 mm (12 in.) of the floor or to a safe location. See FIGURE 15.
- g) All shower valves must be pressure-balance or thermostatic-mixing valves conforming to CSA B125, “Plumbing Fittings”.

FIGURE 15 - Hot Water Tank Fittings & Water Supply Shut-off Valves

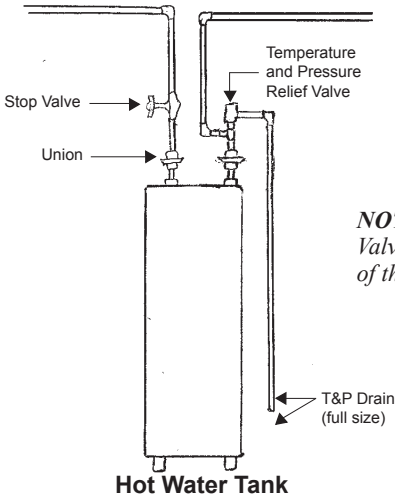

NOTE: A Temperature & Pressure Relief Valve is to be installed within 150 mm (6 in.) of the top of the Hot Water Tank.

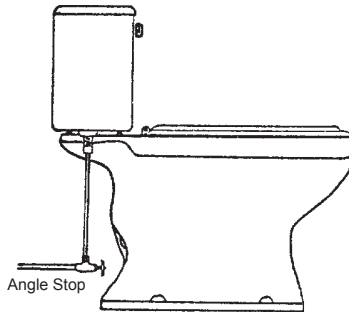

Water Closet Supply

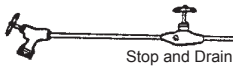

Outside Lawn Service

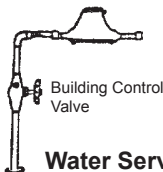

Water Service Supply

How can your potable water system be protected from contamination by cross connection?

A hose bib vacuum breaker must be installed on every hose bib located outside a building or in a garage to isolate garden hose applications thus protecting the potable water supply from contamination.

Connections to potable water systems must be designed so that non-potable water, foreign matter, foreign chemicals or substances that may render the water non-potable cannot enter the system. A cross connection is a direct arrangement of piping which allows the potable water supply to be connected to a line that contains a contaminant. The purpose of a hose bib is to permit easy attachment of a hose for outside watering purposes. The ordinary garden hose is the most common offender as it can be easily connected to the potable water supply and used for a variety of potentially dangerous applications, some of which are listed below:

A garden hose can be:

- a) left submerged in a swimming pool;
- b) placed in elevated locations watering shrubs;
- c) have chemical sprayers attached, for spraying pesticides or herbicides;
- d) positioned lying on the ground that may be contaminated with fertilizer, and garden chemicals;
- e) attached to a laundry tub with the end of the hose submerged in a tub full of detergent; or
- f) connected to the supply lines of bottom fed tanks, and boilers, etc.

See FIGURE 16.

FIGURE 16- Back Siphonage & Backflow Prevention

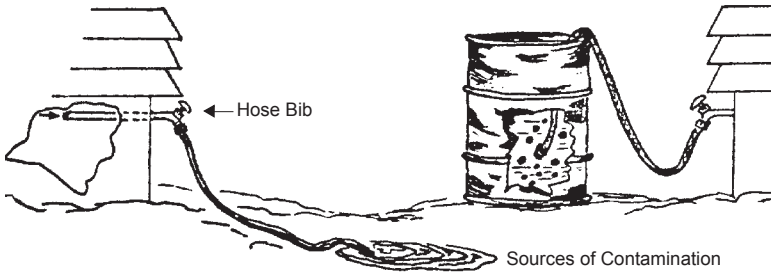

What is Back Siphonage?

A reversal of normal flow in the system caused by a negative pressure (vacuum or partial vacuum) in the supply piping.



Hose Bib Vacuum Breaker

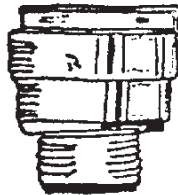

Hose Bib Vacuum Breaker for Frost Proof Hydrants

In-Person Customer Service Hours are:

Tuesday to Friday 8:30 am to 4:30 pm - All Zoning, Permits and Plan Examination services are available at Unit 31 – 30 Fort Street.

Mondays 8:30 am to 4:30 pm are reserved for telephone inquiries and completed application drop-offs. This enables Zoning and Permits staff to process building and development applications received throughout the week.

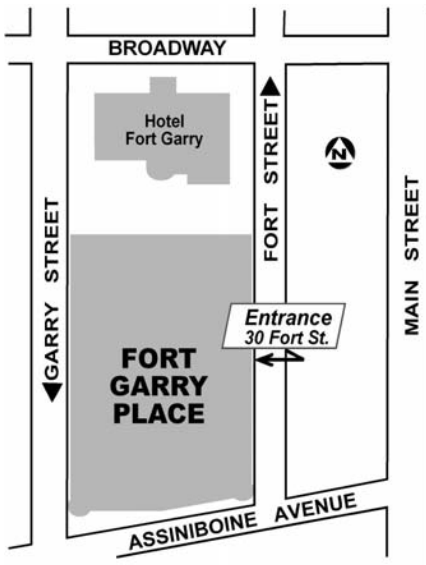



For more information on this booklet

Plan Examination Branch

PH: 204-986-5268

FAX: 204-986-7307

or



Winnipeg
at your service.

City of Winnipeg
Planning, Property and
Development Department
83 - 30 Fort Street
WINNIPEG, Manitoba
R3C 4X7

www.winnipeg.ca/ppd
