

APPENDIX 'E'

CRASH ATTENUATION BARRIERS PRODUCT INFORMATION

QuadGuard® II

Assembly Manual

Part No. 115270B

Revision A December 2012



TRINITY
HIGHWAY PRODUCTS
ENERGY ABSORPTION SYSTEMS

QuadGuard® II

Assembly Manual



Important: These instructions are to be used only in conjunction with the assembly, maintenance, and repair of QuadGuard® II systems. These instructions are for standard assembly specified by the appropriate highway authority only. In the event the specified system assembly, maintenance, or repair would require a deviation from standard assembly parameters, contact the appropriate highway authority engineer. This system has been accepted for use by the Federal Highway Administration for use on the national highway system under strict criteria utilized by that agency. Energy Absorption Systems representatives are available for consultation if required.

This Manual must be available to the worker overseeing and/or assembling the product at all times. For additional copies, contact Energy Absorption Systems at (888) 323-6374 or download from websites below.

The instructions contained in this Manual supersede all previous information and Manuals. All information, illustrations, and specifications in this Manual are based on the latest QuadGuard® II system information available to Energy Absorption Systems at the time of printing. We reserve the right to make changes at any time. Please contact Energy Absorption Systems to confirm that you are referring to the most current instructions.

Table of Contents

Customer Service Contacts	3
Important Introductory Notes	3
Recommended Safety Rules for Assembly	4
Safety Symbols	5
Warnings and Cautions.....	5
Limitations and Warnings.....	6
System Overview	7
Recommended Tools.....	8
System Assembly for Narrow Hazards	13
Site Preparation/Foundation	14
System Assembly for Wide Hazards.....	32
Site Preparation/Foundation	33
Transition Panel Types	35
MP-3 [®] Polyester Anchoring system	51
Horizontal Assemblies	53
MP-3 [®] Assembly Cautions.....	55
Maintenance and Repair.....	56
Inspection Frequency.....	56
Visual Drive-By Inspection	56
Walk-Up Inspection	56
Post-Impact Instructions	58
Parts Ordering Procedure	62

Customer Service Contacts

Energy Absorption Systems (a Trinity Highway Products company) is committed to the highest level of customer service. Feedback regarding the QuadGuard® II system, its assembly procedures, supporting documentation, and performance is always welcome. Additional information can be obtained from the contact information below:

Energy Absorption Systems:

Telephone:	(888) 323-6374 (USA Only) (214) 589-8140 (USA or International)
E-mail:	customerservice@energyabsorption.com
Internet: Energy Absorption Systems Trinity Highway Products, LLC	http://www.energyabsorption.com http://www.highwayguardrail.com

Important Introductory Notes

Proper assembly of the QuadGuard® II is essential to achieve performance of the system under appropriate federal and state criteria. These instructions should be read in their entirety and understood before assembling the QuadGuard® II. These instructions are to be used only in conjunction with the assembly of the QuadGuard® II and are for standard assemblies only as specified by the applicable highway authority. In the event your system assembly requires or involves deviation from standard parameters or, during the assembly process a question arises, please contact the appropriate highway authority that specified this system at this particular location for guidance. Energy Absorption Systems is available for consultation with that agency. These instructions are intended for an individual who is qualified to both read and accurately interpret them as written. They are intended for the individual who is experienced and skilled in the assembly of highway products which are specified and selected by the highway authority.

A set of product and project shop drawings will be supplied by Energy Absorption Systems. The shop drawings will be for each section of the assembly. These drawings should be reviewed and studied thoroughly by a qualified individual who is skilled in interpreting them before the start of any assembly.



Important: Read safety instructions thoroughly and follow the assembly directions and suggested safe practices before assembling, maintaining, or repairing the QuadGuard® II system. Failure to follow this warning can result in serious injury or death to workers and/or bystanders. It further compromises the acceptance of this system by the FHWA. Please keep these instructions for later use.



Warning: Ensure that all of the QuadGuard® II system Warnings, Cautions, and Important statements within the QuadGuard® II Manual are completely followed. Failure to follow this warning could result in serious injury or death in the event of a collision.

Recommended Safety Rules for Assembly

*** Important Safety Instructions ***

This Manual must be kept in a location where it is readily available to persons who assemble, maintain, or repair the QuadGuard® II system. Additional copies of this Manual are immediately available from Energy Absorption Systems by calling (888) 323-6374. Please contact Energy Absorption Systems if you have any questions concerning the information in this Manual or about the QuadGuard® II system. This Manual may also be downloaded directly from the websites indicated below.

Always use appropriate safety precautions when operating power equipment, mixing chemicals, and when moving heavy equipment or QuadGuard® II components. Gloves, apron, safety goggles, steel toe boots, and back protection shall be used.

Safety measures incorporating traffic control devices specified by the highway authority must be used to provide safety for personnel while at the assembly, maintenance, or repair site.

Safety Symbols

This section describes the safety symbols that appear in this QuadGuard® II Manual. Read the Manual for complete safety, assembly, operating, maintenance, repair, and service information.

<u>Symbol</u>	<u>Meaning</u>
---------------	----------------



Safety Alert Symbol: Indicates Danger, Warning, or Caution. Failure to read and follow the Danger, Warning, Safety, or Caution indicators could result in serious injury or death to the workers and/or bystanders.

Warnings and Cautions

Read all instructions before assembling, maintaining, or repairing the QuadGuard® II system.



Warning: Do not assemble, maintain, or repair the QuadGuard® II system until you have read this Manual thoroughly and completely understand it. Ensure that all Warnings, Cautions, and Important Statements within the Manual are completely followed. Please call Energy Absorption Systems at (888) 323-6374 if you do not understand these instructions. Failure to follow this warning could result in serious injury or death in the event of a collision.



Warning: Safety measures incorporating appropriate traffic control devices specified by the highway authority must be used to protect all personnel while at the assembly, maintenance, or repair site. Failure to follow this warning could result in serious injury or death in the event of a collision.



Warning: Use only Energy Absorption Systems parts that are specified herein for the QuadGuard® II for assembling, maintaining, or repairing the QuadGuard® II system. Do not utilize or otherwise combine parts from other systems even if those systems are other Energy Absorption Systems or Trinity Highway Products systems. Such configurations have not been tested, nor have they been accepted for use. Assembly, maintenance, or repairs using unspecified parts or accessories is strictly prohibited. Failure to follow this warning could result in serious injury or death in the event of a vehicle impact with an UNACCEPTED system.



Warning: Do NOT modify the QuadGuard® II system in any way. Failure to follow this warning could result in serious injury or death in the event of a collision.



Warning: Ensure that the QuadGuard® II system and delineation used meet all federal, state, specifying agency, and local specifications. Failure to follow this warning could result in serious injury or death in the event of a collision.



Warning: Ensure that your assembly meets all appropriate Manual on Uniform Traffic Control Devices (MUTCD) and local standards. Failure to follow this warning could result in serious injury or death in the event of a collision.

Limitations and Warnings

Energy Absorption Systems, in compliance with the National Cooperative Research Highway Program 350 (NCHRP Report 350) "Recommended Procedures for the Safety Performance of Highway Safety Features", contracts with FHWA approved testing facilities to perform crash tests, evaluation of tests, and submittal of results to the Federal Highway Administration for review.

The QuadGuard® II system has been accepted by FHWA as meeting the requirements and guidelines of NCHRP Report 350* TL-1 (2 Bay narrow system), TL-2 (2 Bay narrow system and 3 Bay wide system) and TL-3 (5 Bay system). The NCHRP Report indicates that these tests typically evaluate product performance by closely simulating actual impacts involving a typical range of vehicles on our roadways, from lightweight cars (approx. 820kg [1800 lb.]) to full size pickup trucks (approx. 2000 kg [4400 lb.]) as specified by the FHWA. A product can be certified for multiple Test Levels. The QuadGuard® II has been accepted to the Test Level(s) as shown below:

Test Level 1: 50 km/h [31 mph]

Test Level 2: 70 km/h [44 mph]

Test Level 3: 100 km/h [62 mph]

These FHWA directed tests are not intended to represent the performance of systems when impacted by every vehicle type or every impact condition existing on the roadway. This system is tested only to the test matrix criteria of NCHRP 350 as approved by FHWA.

These tests are not intended to represent the performance of products when impacted by every vehicle type or every impact condition.

Energy Absorption Systems does not represent nor warrant that the results of these controlled tests show that vehicle impacts with the products in other conditions would necessarily avoid injury to person(s) or property. Impacts that exceed criteria capabilities of the product may not result in acceptable impact performance as outlined in NCHRP Report 350, relative to structural adequacy, occupant risk and vehicle trajectory. Energy Absorption Systems expressly disclaims any warranty or liability for injury or damage to persons or property resulting from any impact, collision, or harmful contact with products, other vehicles, or nearby hazards or objects by any vehicle, object or person, whether or not the products were assembled by or in the presence of Energy Absorption Systems representatives or by third parties.

The QuadGuard® II system is intended to be assembled, delineated, and maintained in accordance with specific state and federal guidelines. It is important to select the most appropriate product configuration for a site. The customer should be careful to properly select, assemble, and maintain the product. Careful evaluation of the site geometry, vehicle population type, speed, traffic direction, and visibility are some of the elements that require evaluation in the proper selection of a safety appurtenance. For example, curbs could cause an untested effect on an impacting vehicle. Before deployment of this system at any location, these issues need to be fully discussed with the appropriate highway authority planning and specifying the assembly.

After an impact occurs, the product should be restored to its original condition as soon as possible. When a potentially reusable safety product is impacted, it is still necessary to restore the product to its original length and inspect all the components as necessary.

System Overview

The QuadGuard® II is a potentially reusable, re-directive, non-gating crash cushion for hazards ranging in width from 610 mm to 3200 mm (24" to 126"). It consists of energy-absorbing cartridges surrounded by a framework of Quad-Beam™ Panels.

The QuadGuard® II system utilizes two types of cartridges in a "staged" configuration to address both lighter cars and heavier, high center-of-gravity vehicles. Its modular design allows the system length to be tailored to the design speed of a site. See the QuadGuard® II Product Manual to determine the appropriate number of Bays for a given speed.

Impact Performance

The 5 Bay QuadGuard® II systems have successfully passed the requirements stipulated in NCHRP Report 350, Test Level 3 tests with both the light car and pickup at speeds of up to 100 km/h [62 mph] at angles up to 20 degrees.

During head-on impacts, within NCHRP Report 350 criteria, the QuadGuard® II telescopes rearward and crushes to absorb the energy of impact. When impacted from the side, within the applicable NCHRP 350 criteria, it safely redirects the vehicle back toward its original travel path and away from the hazard.

Recommended Tools

Documentation

- Manufacturer's Assembly Manual
- Manufacturer's Drawing Package

Cutting equipment

- Rotary Hammer Drill
- Rebar cutting bit
- Concrete drill bits – 22 mm [7/8"] (*Two Fluted)
- Grinder, Hacksaw or Torch (optional)
- Drill motor
- Drill bits 1/16" through 7/8"

*Energy Absorption Systems recommends using two fluted drill bits to achieve optimum tensile strength when applying the MP-3[®] anchoring system.

Hammers

- Sledgehammer
- Standard hammer

Wrenches

- Heavy duty impact wrench
- Standard adjustable wrench
- 1/2" drive sockets: 9/16", 11/16", 3/4", 15/16", 1 1/8", 1 1/4"
- 1/2" drive Deep sockets: 15/16", 1 1/4"
- 1/2" drive Ratchet and attachments
- 1/2" drive Breaker bar – 24" long
- 1/2" drive Torque wrench: 200 ft-lb
- Crescent wrench: 300 mm [12"]
- Allen wrench: 3/8"
- Impact Wrench: 1/2"

Personal Protective equipment

- Safety Glasses
- Gloves
- Apron for MP-3[®] application

Miscellaneous

- Traffic control equipment
- Lifting and moving equipment (A lifting device is preferred although a forklift can be used.) Minimum 5,000 lb. capacity required.
- Air Compressor (100 psi minimum) and Generator (5 kW)
- Long pry bar
- Drift pin 300 mm [12"]
- Center punch
- Tape measure 7.5 m [25']
- Chalk line
- Concrete marking pencil
- Nylon bottle brush for cleaning 7/8" drilled holes
- Rags, water, and solvent for touch-up

Note: The above list of tools is a general recommendation. Depending on specific site conditions and the complexity of the assembly specified by the appropriate highway authority, additional or fewer tools may be required. Decisions as to what tools are needed to perform the job are entirely within the discretion of the specifying highway authority and the authority's selected contractor performing the assembly of the system at the authority's specified site.

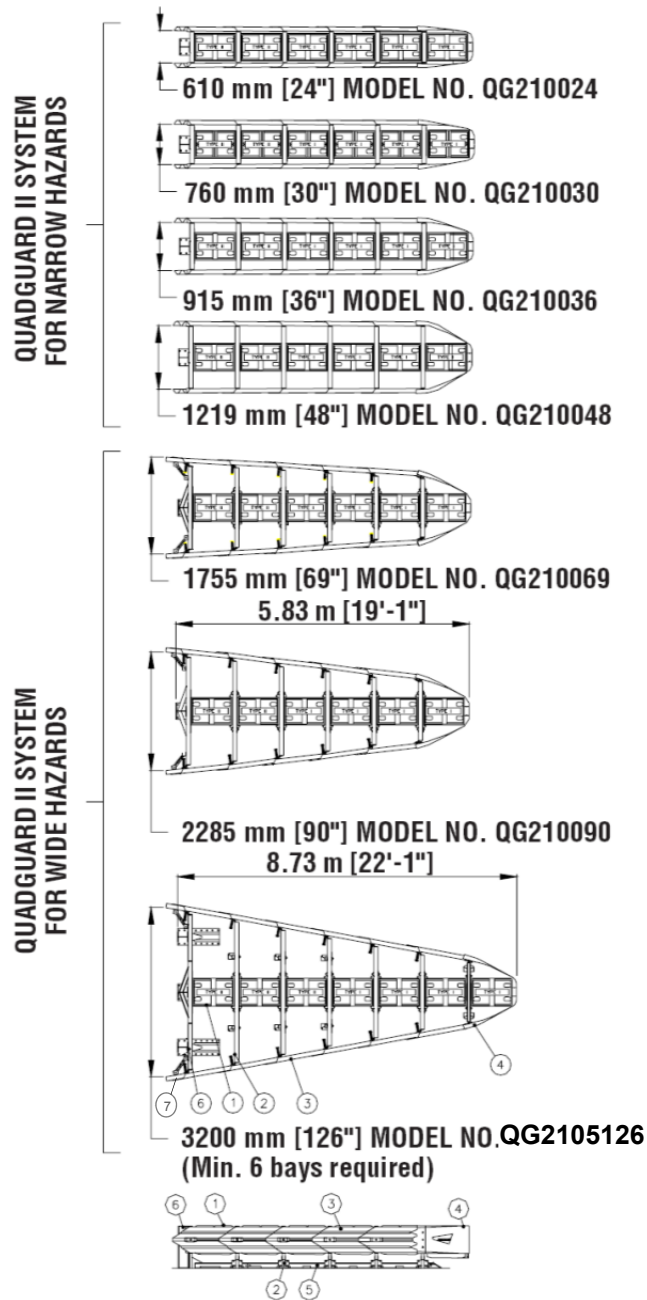

Figure 1 Plans & Elevation
 (Five Bay systems with Tension Strut Backups shown, except as noted)

Key

- 1) Cartridge
- 2) Diaphragm
- 3) Quad-Beam™ Fender Panel
- 4) Nose Cover
- 5) Monorail
- 6) Backup
- 7) Side Panel

How to Determine Left/Right

To determine left from right when ordering parts, stand in front of the system facing the hazard. Your left is the system's left and your right is the system's right.

Counting the Number of Bays

One Bay consists of one Cartridge, one Diaphragm, two Fender Panels, etc. The Nose section is not considered a Bay, though there is a Cartridge in the Nose of each system. Note that this means there will always be one more Cartridge in the system than the number of Bays in the system. To determine number of Bays, count Fender Panels on one side (See Figure 2). Five Bay system shown.

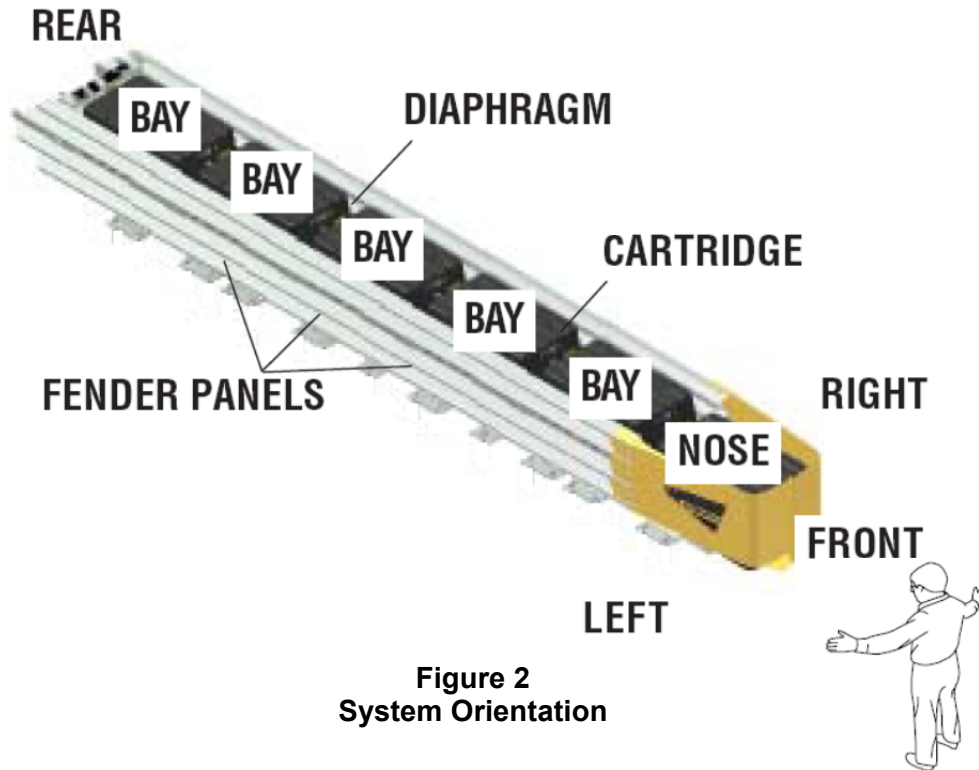

Figure 2
System Orientation

Measuring the Width

The QuadGuard® II system is available in seven nominal widths:

- 610 mm [24"]
 - 760 mm [30"]
 - 915 mm [36"]
 - 1219 mm [48"]
 - 1755 mm [69"]
 - 2285 mm [90"]
 - 3200 mm [126"]
- (Minimum 3 Bays Required)
- (Minimum 6 Bays Required)

The nominal width of a system with Tension Strut Backup is the width between Side Panels behind the Backup (See Figure 3).

The nominal width of a system with Concrete Backup is the width of the Concrete Backup at location shown in Figure 4.

The outside width of the system is approximately 150 mm [6"] to 230 mm [9"] wider than the nominal width. The width of the system is not the same as the width of the Backup.

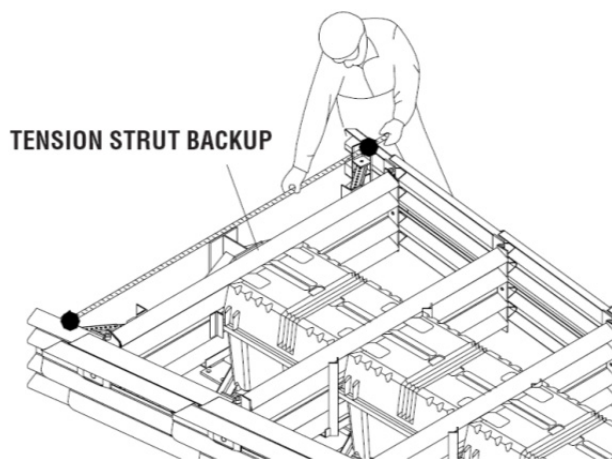

Figure 3
Width of system with Tension Strut Backup

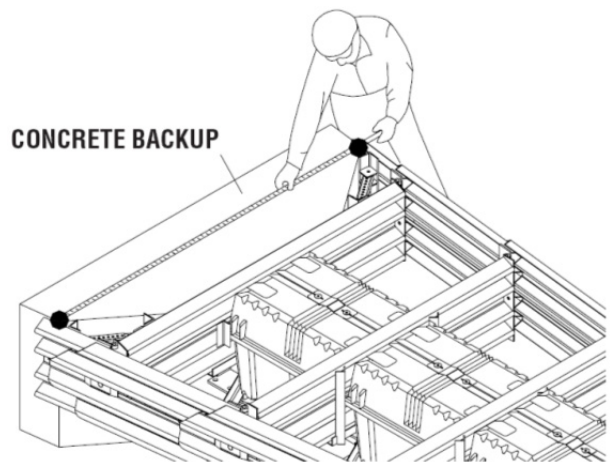

Figure 4
Width of system with Concrete Backup

System Assembly for Narrow Hazards

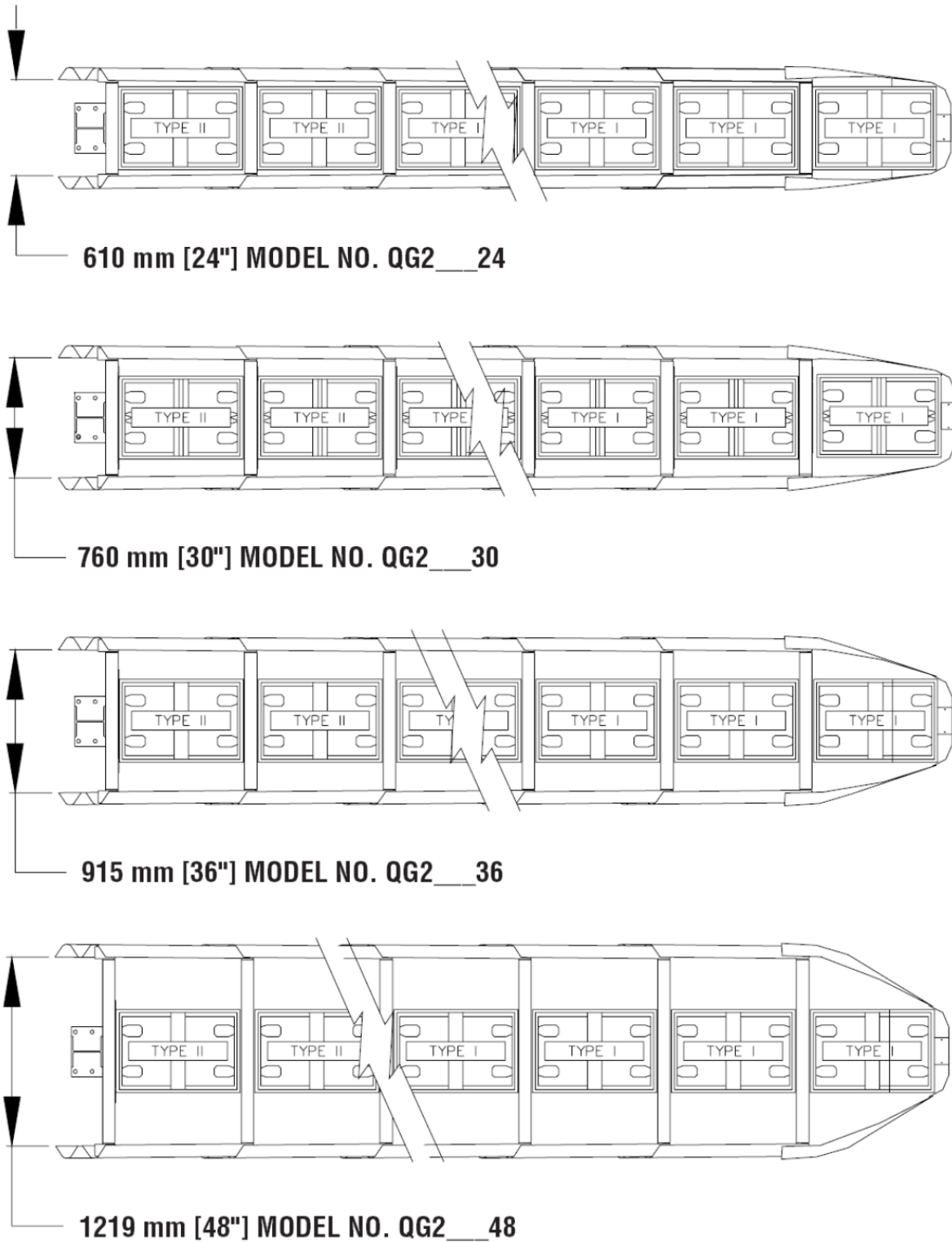

Figure 5
Narrow System and Model Numbers

Site Preparation/Foundation

A QuadGuard® II should be assembled only on an existing or freshly placed and cured concrete base (28 MPa [4000 psi] minimum). Location and orientation of the concrete base and attenuator must comply with project plans or as otherwise determined by the resident project engineer.

Recommended dimension and reinforcement specifications for new concrete foundations are provided in Energy Absorption Systems concrete foundation drawings, supplied with the system. The system may be assembled on a non-reinforced concrete roadway (minimum 200 mm [8"] thick). Deployment cross-slope shall not exceed 8% and should not twist more than 2% over the length of the system; the foundation surface shall have a light broom finish.



Caution: Accurate placement of all steel rebar is critical to avoid interference with the concrete anchor bolts.

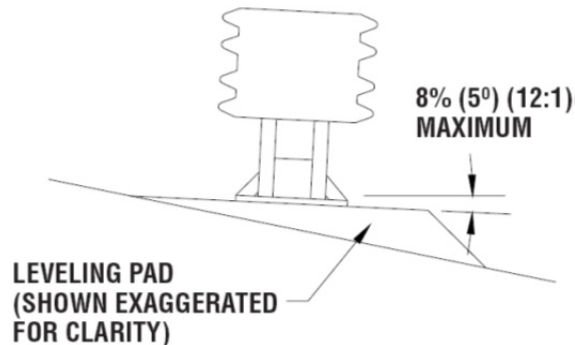

Figure 6
Cross-Slope



Warning: Location of the Backup in relation to nearby objects will affect the operation of the attenuator. Upon impact, the Fender Panels telescope rearward and extend beyond the rigid Backup as much as 876.3 mm [34.5"]. Position the Backup so that the rear ends of the last Fender Panels are a minimum of 760 mm [30"] forward of objects that would otherwise interfere with movement of the rearmost Fender Panels. Failure to comply with this requirement will result in impaired system performance offering motorists less protection and causing component damage.

Inspect Shipping

Before deploying the QuadGuard® II system, check the received parts against the shipping list supplied with the system. Make sure all parts have been received.

Assembly Procedures

Note: The Drawing Package supplied with the QuadGuard® II system must be used with these instructions for proper assembly and should take precedence over these general instructions.

1) Determine Backup & Transition Type

The QuadGuard® II system is available with a Tension Strut Backup or a Concrete Backup. See Figure 7 and 8, along with the Backup Assembly drawing, to determine which type of Backup is being deployed.

A Transition Panel or Side Panel must be used on each side of the Backup. A Side Panel is not needed when a Transition Panel is used. Several types of Transitions are available for use with the QuadGuard® II system. See Figures 9 through 14 and the Drawing Package to determine which type of Panels to attach.

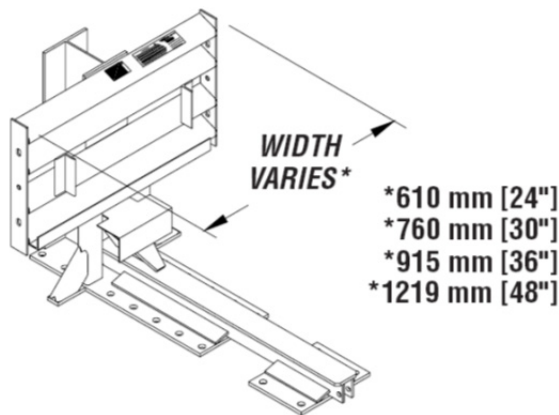

Figure 7
Tension Strut Backup

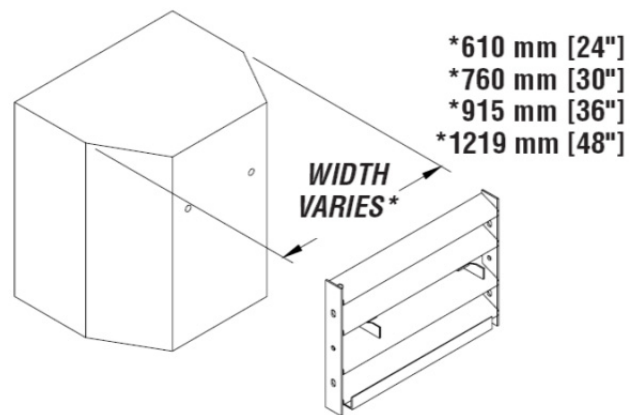

Figure 8
Concrete Backup

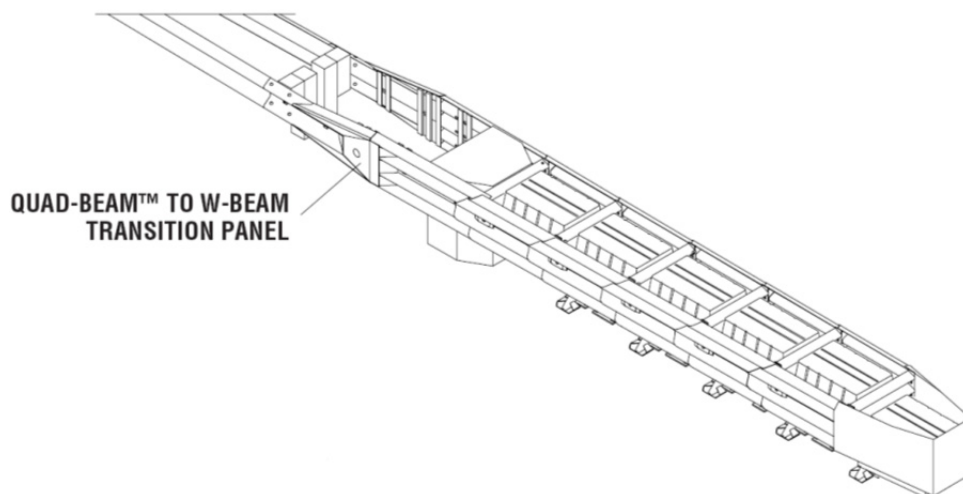

Figure 9
Transitioning the QuadGuard® II System

Transition Panel Types

Note: The proper Transition Panel or Side Panel must be used for impact performance of the system. The correct Panel(s) to use will depend on the direction of traffic and what type of barrier or hazard the QuadGuard® II system is shielding. Contact the Customer Service Department prior to deployment if you have any questions.

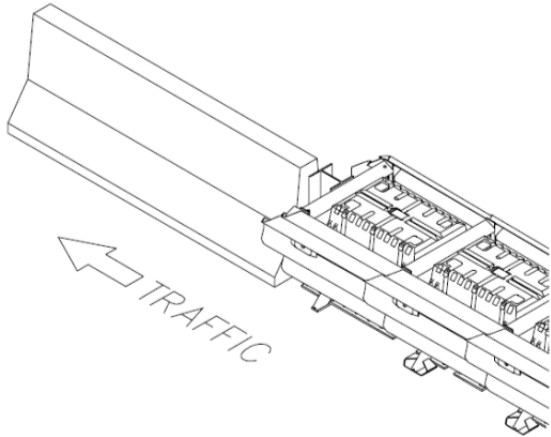

Figure 10
No Transition

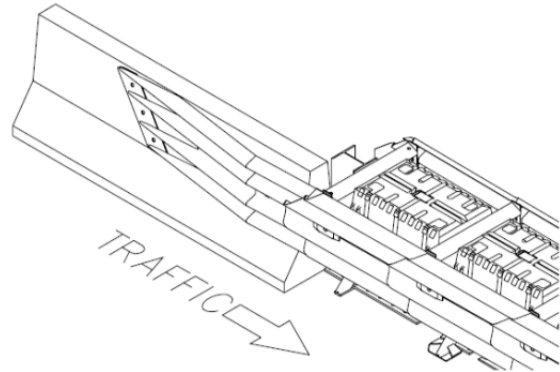

Figure 11
Quad-Beam™ to Safety Shape Barrier Transition Panel

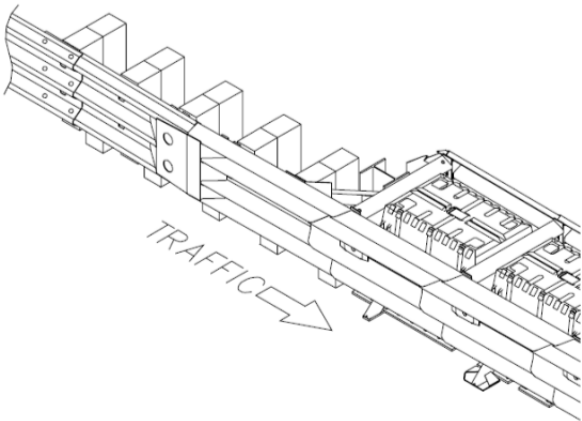

Figure 12
Quad-Beam™ to Thrie-Beam Transition Panel

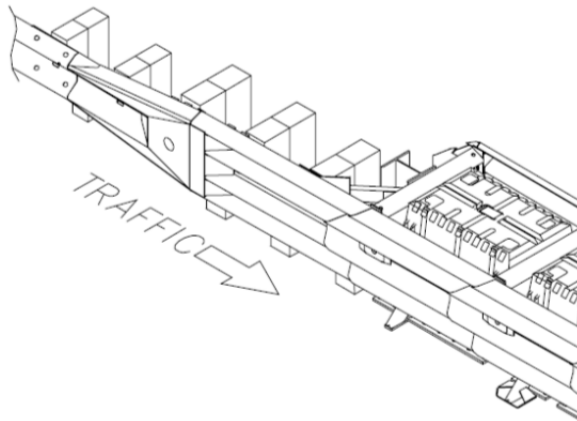

Figure 13
Quad-Beam™ to W-Beam Transition Panel

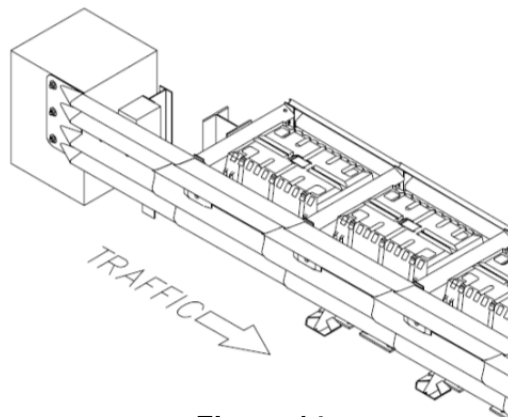

Figure 14
Quad-Beam™ End Shoe Transition Panel

2) Mark System Location

Locate the centerline of the system by measuring the proper offset from the hazard. See the Drawing Package supplied with the system. Place chalk line to mark the centerline of the system. Mark a construction line parallel to the center line and offset 165 mm [6.5"] to one side as shown in Figure 15. The edge of the Monorail will be positioned on this line.

Note: The concrete foundation shall comply with the project plans supplied with the system.



Warning: Location of system with respect to the hazard is critical and dependent on the type of Transition Panel used. See the Project Plans supplied with the system for details.



Figure 15
(Top view of concrete foundation)

3) Anchor the Backup

A) Concrete Backup Construction (Figure 16)

Locate Backup Face Plate using the Backup Assembly drawing. Verify that any applicable Transition Panels fit properly before anchoring the Face Plate. Drill anchor holes in the Concrete Backup using the Face Plate as a template. Anchor the Face Plate to the Concrete Backup using the MP-3[®] Anchoring system (horizontal kit) supplied with the QuadGuard[®] II system (See “MP-3[®] Polyester Anchoring System” section on Page 51).



Warning: Every hole and slot in Backup and Monorail must be anchored by an MP-3[®] stud.

B) Tension Strut Backup Assembly (Figure 17)

Locate Tension Strut Backup and Monorail on foundation with side of Monorail on the construction line (See Figure 20 on Page 20). Verify that any applicable Transition Panels fit properly before anchoring Backup. Drill anchor holes in foundation using the Backup as template. Anchor the Backup to the concrete foundation using the MP-3[®] Anchoring system (Vertical kit) supplied with the QuadGuard II system (See “MP-3[®] Polyester Anchoring System” section on Page 51).

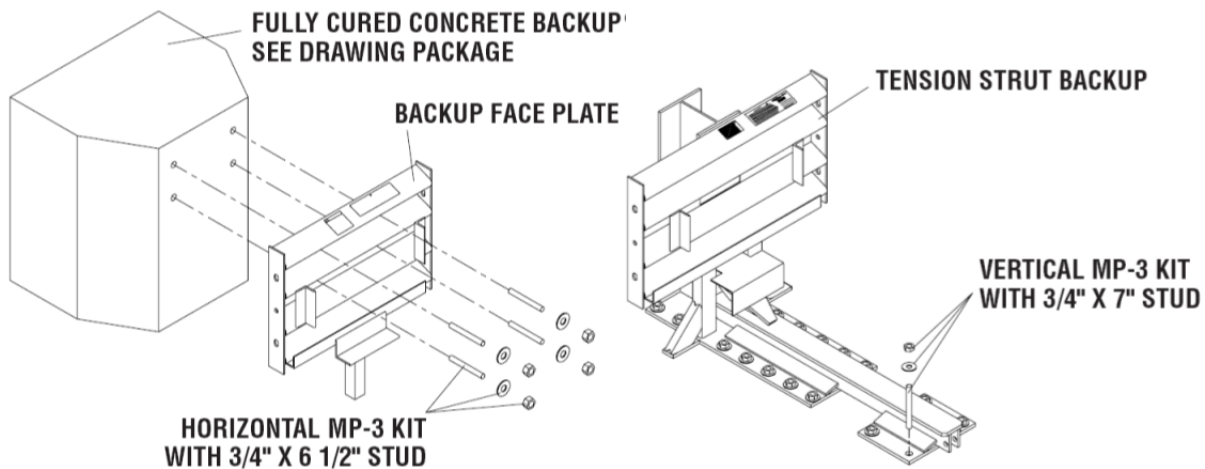

Figure 16
Anchoring Backup Face Plate to
Concrete Backup

Figure 17
Anchoring Tension Strut Backup
to Foundation

4) Anchor the Monorail

A) Monorail Construction for Concrete Backup (Figure 19)

Locate Monorail on foundation with side of Monorail on the construction line and rear edge of Monorail foot 10" forward of front face of Concrete Backup (See Figure 19).

Orient the Monorail so that the Monorail tongues face Backup (See Figure 19).

Drill 140 mm [5 1/2"] deep anchor holes using the Monorail as a template. Do not drill through foundation.



Warning: Every hole and slot in Backup and Monorail must be anchored by an MP-3[®] stud.

Anchor each Monorail section using the MP-3[®] vertical kits provided. See Figure 18 and the MP-3[®] Polyester Anchoring System Instructions included with this Manual. It is important to attach each segment of Monorail in alignment from the back to the front of the system (± 6 mm [1/4"]).



Warning: Improper alignment at the Monorail Sections will prevent proper system collapse during an impact.

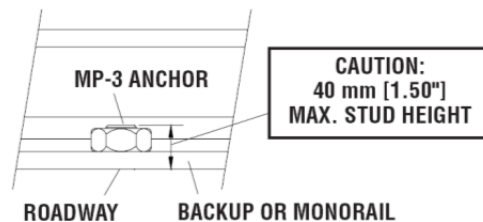

Figure 18
Proper Stud Height

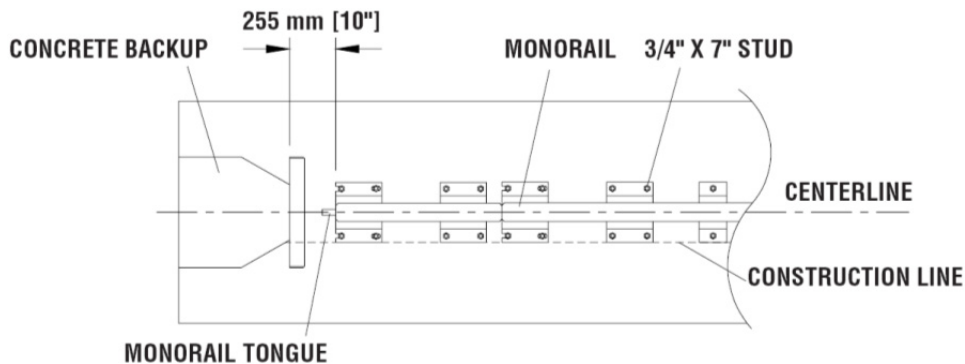

Figure 19
Monorail Location for Concrete Backup

B) Monorail Construction for Tension Strut Backup (Figure 20)

Locate Monorail on foundation with side of Monorail on the construction line and rear edge of Backup foot 4" forward of edge of foundation (See Figure 20).

Orient the Monorail so that the Monorail tongues face the Backup (See Figure 19 on Page 19).

Drill 140 mm [5 1/2"] deep anchor holes using the Monorail as a template. Do not drill through foundation.



Warning: Every hole and slot in Backup and Monorail must be anchored by an MP-3[®] stud.

Anchor each Monorail section using the MP-3[®] vertical kits provided. See Detail 20a and the MP-3[®] Polyester Anchoring System Instructions included with this Manual. It is important to attach each segment of Monorail in alignment from the back to the front of the system (± 6 mm [1/4"]).



Warning: Improper alignment at the Monorail splice joints will prevent proper system collapse during an impact.

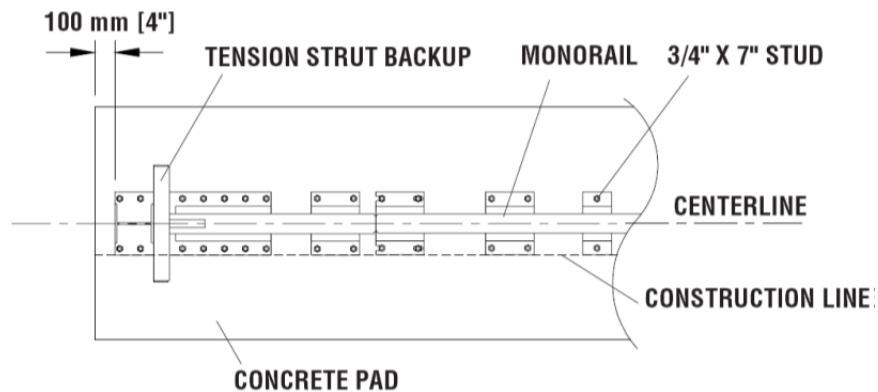
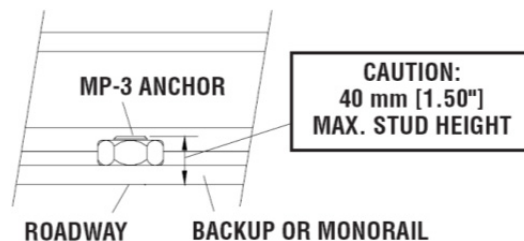

Figure 20

Backup and Monorail Location for Tension Strut Backup



Detail 20a

Proper Stud Height

5) Attach Side Panels and/or Transition Panels to Backup Assembly

Attach Transition Panel or Side Panel to side of Backup using 5/8" hex bolt and 5/8" rail nut (two places - top and bottom holes only). See Figure 21 and Backup Assembly drawing.

Note: A Side Panel is not needed when a Transition Panel is used.

Construction tip:

Use drift pin to align the center hole of the Panel with the center hole of the Backup before inserting the rail bolts.

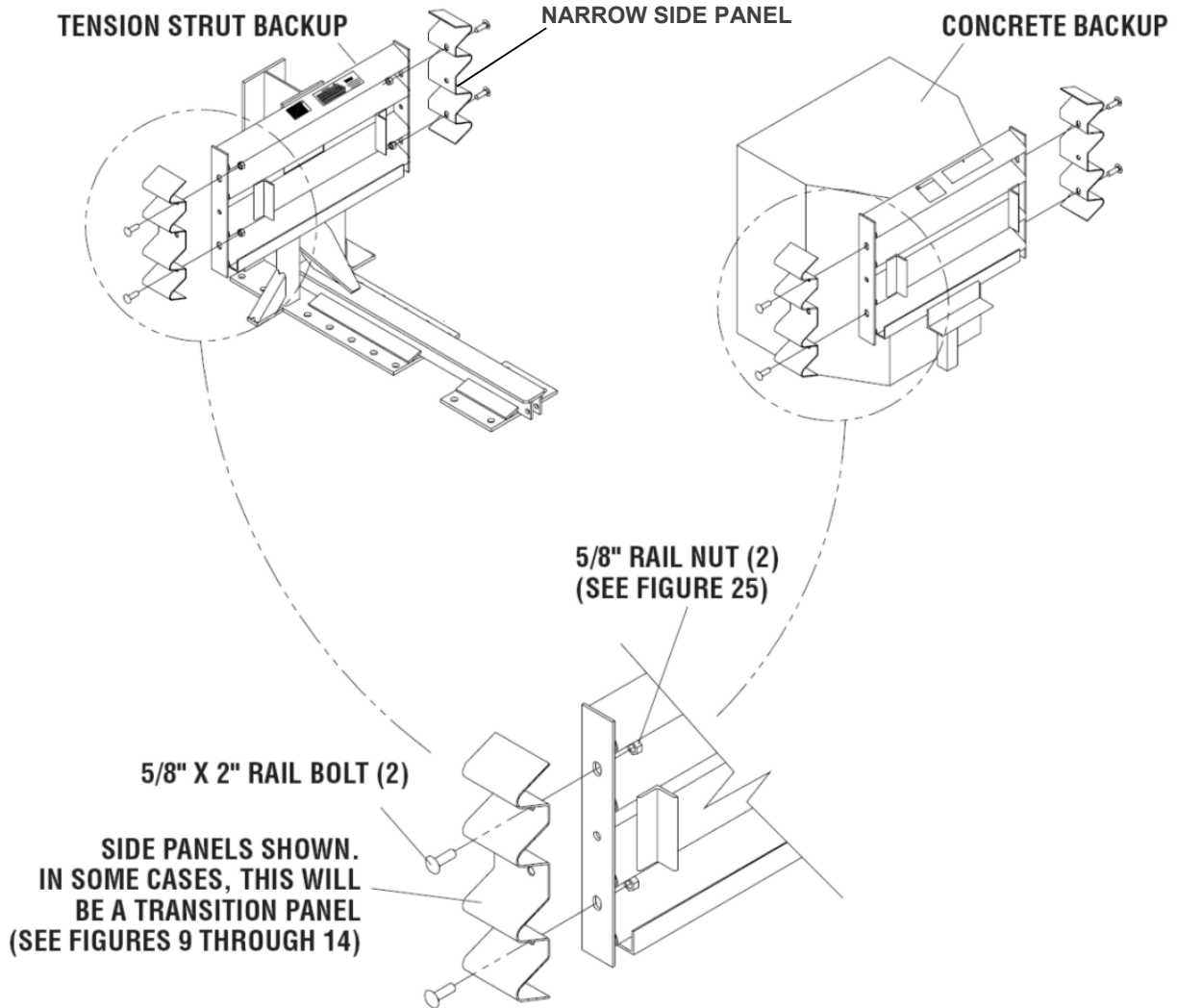

Figure 21
Side Panel/Transition Panel Attachment

6) Attach Monorail Guides

Attach Monorail guides to Diaphragm as follows:

Insert 3/4" x 2" G8 hex bolt through Monorail guide and Diaphragm, oriented as shown in Figure 22. Secure with 3/4" lock washer and 3/4" hex nut (typical 4 places). See also Diaphragm Assembly drawing. Shims are sandwiched between the Rail Guide and Diaphragm.

Repeat process for each Diaphragm.

7) Attach Diaphragms

Orient a Diaphragm so that the front face of the Diaphragm shape faces toward the Nose of the system as shown in Figure 23. Slide one Diaphragm all the way to the Backup to ensure the system is able to collapse properly during impact. Once this has been verified, slide the Diaphragm forward to approximately 915 mm [36"] in front of the Backup. Orient and slide all other Diaphragms onto Monorail and position each approximately as shown in Figure 24.

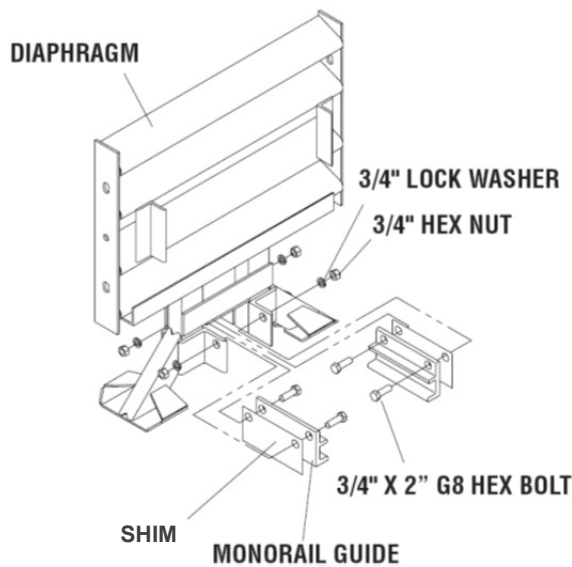

Figure 22
Monorail Guide Attachment

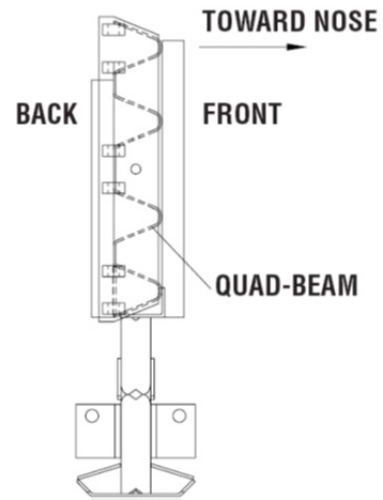

Figure 23
Diaphragm Orientation

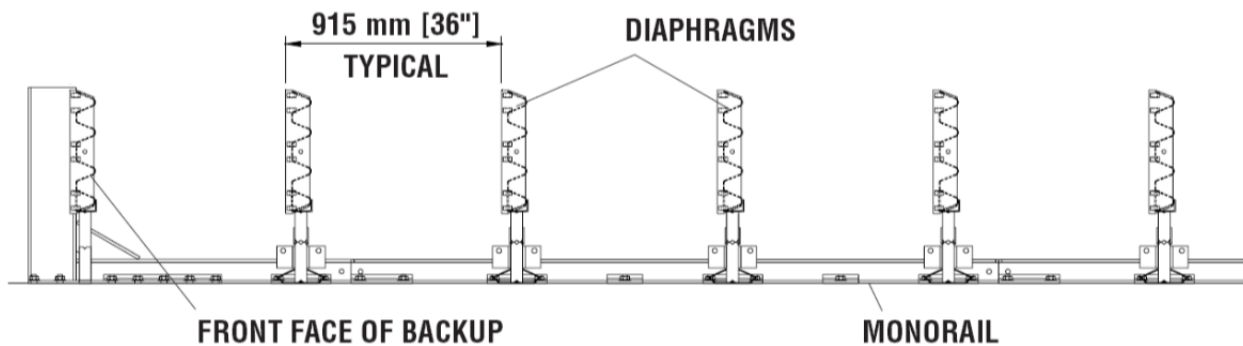

Figure 24
Diaphragm Spacing

8) Attach Fender Panels

Note: Do not mix the 5/8" rail nuts (large) with the 5/8" hex nuts (small) (See Figure 25).

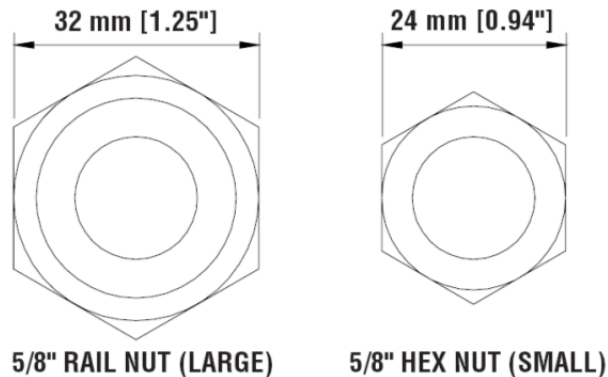

Figure 25
Rail Nuts are Oversize

Starting at the Backup, attach left and right Fender Panels shown on Page 24 and Fender Panel Assembly drawing.

Step 1

Place the Fender Panel so that the center of the slot of the rearward Diaphragm is lined up with the approximate center of the slot in the Fender Panel.

Attach Mushroom Washer Assembly as shown in Figure 26 and Detail 26a and Detail 26b, but do not torque at this time. This (Step 1) helps to balance the Fender Panel.

Step 2

Slide the Fender Panel forward until the holes in the Fender Panel line up with the holes in the forward Diaphragm.

Step 3

Use a drift pin to align the center hole of the Fender Panel with the center hole of the Diaphragm.

Step 4

Attach the front of the Fender Panels to the next Diaphragm using two rail bolts and large hex nuts per side. Use only the top and bottom holes; leave the center hole open until the next Fender Panel is attached.

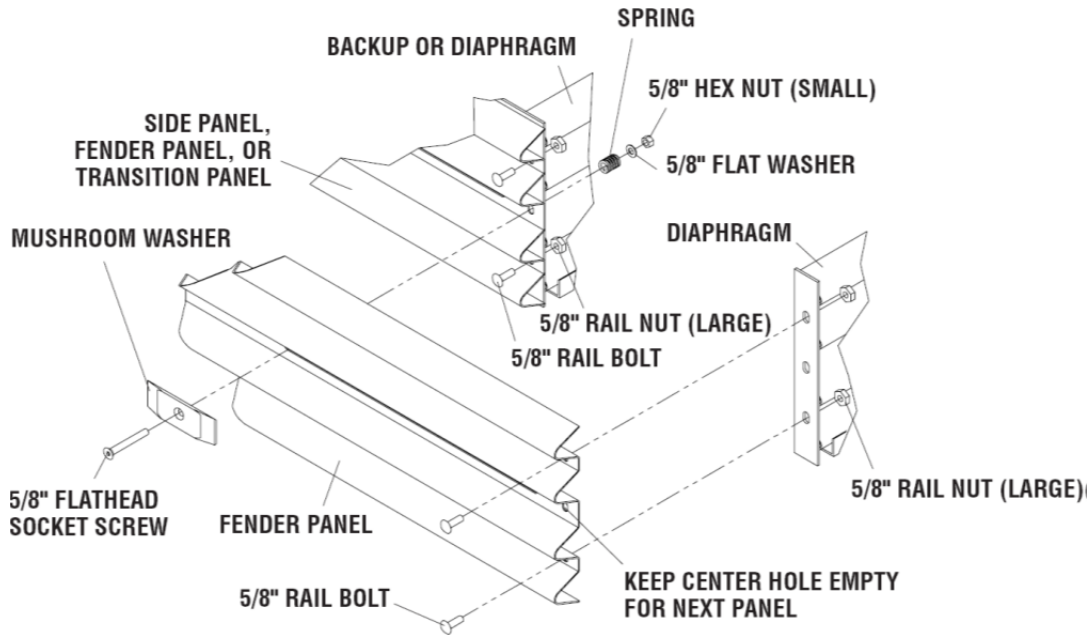
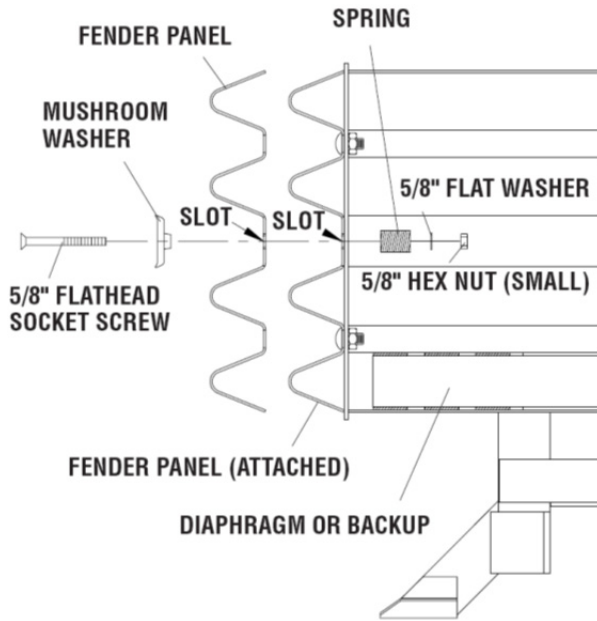

Figure 26
Fender Panel Assembly

Step 5

Be sure Mushroom Washer lays flat against the Fender Panel as shown in Figure 26b. Standoff on Mushroom Washer must be seated completely through slot.



Detail 26a
Mushroom Washer Attachment

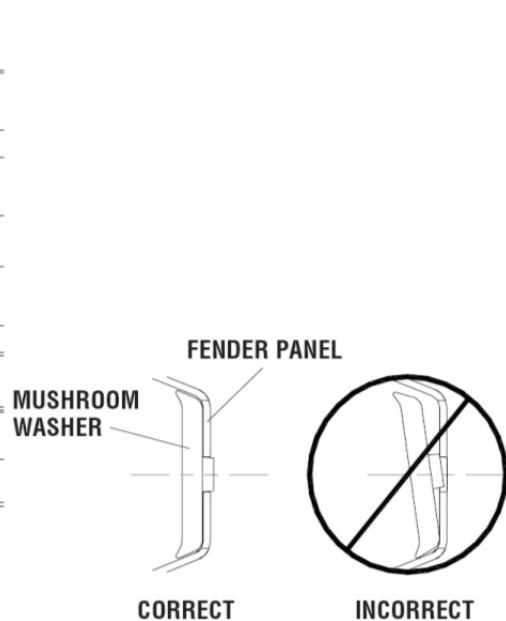

Detail 26b
Mushroom Washer Orientation

Step 6

Check Diaphragm spacing to ensure 915 mm [36"] between rear faces of consecutive Diaphragms as shown in Figure 27 and Fender Panel Assembly drawing.

Step 7

Once proper spacing has been achieved, torque the Mushroom Washer Assembly (small hex) nut until it reaches the end of the threads.

Assemble the remaining Diaphragms and Fender Panels following the same procedures.

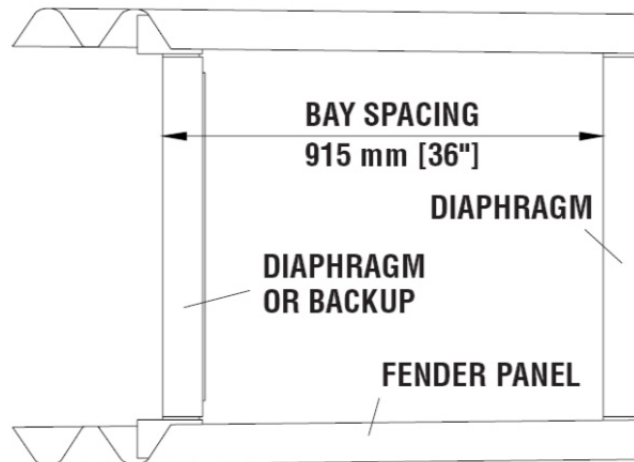

Figure 27
Proper Spacing Between Diaphragms

9) Attach End Cap

Using 5/8" x 3 1/2" G5 hex bolt, 5/8" hex nut and 5/8" lock washer, attach the End Cap to the front of the first Monorail segment as shown in Figure 28 and Monorail Assembly drawing.

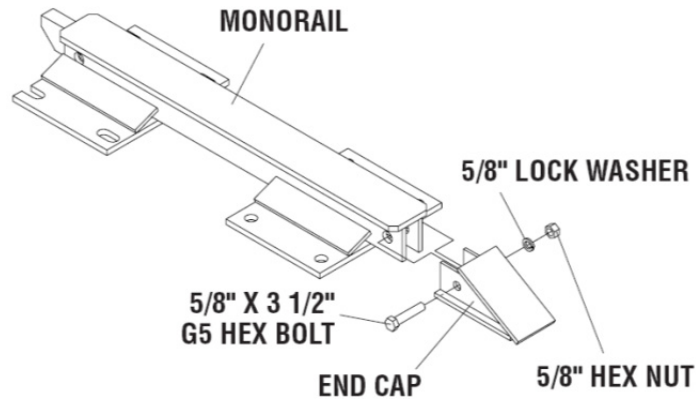

Figure 28
Monorail End Cap Assembly

10) Attach Cartridge Support Brackets

Attach lower Cartridge Support Bracket to front and back of all Diaphragms and front of Backup, as shown in Figures 30 to 32 Diaphragm Assembly drawings, and Backup Assembly drawings.

Note: 610 mm [24"] wide systems do not have Side Cartridge Support Brackets: 762 mm [30"], 914 mm [36"] and 1219 mm [48"] wide systems have Side Cartridge Support Brackets welded to the Backup and Diaphragms.

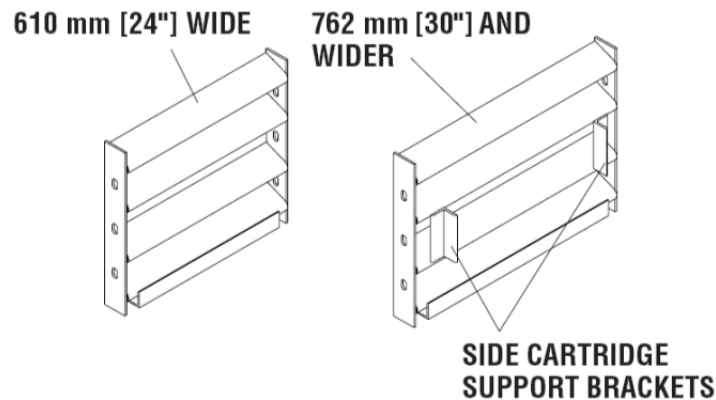

Figure 29
Side Cartridge Support Brackets

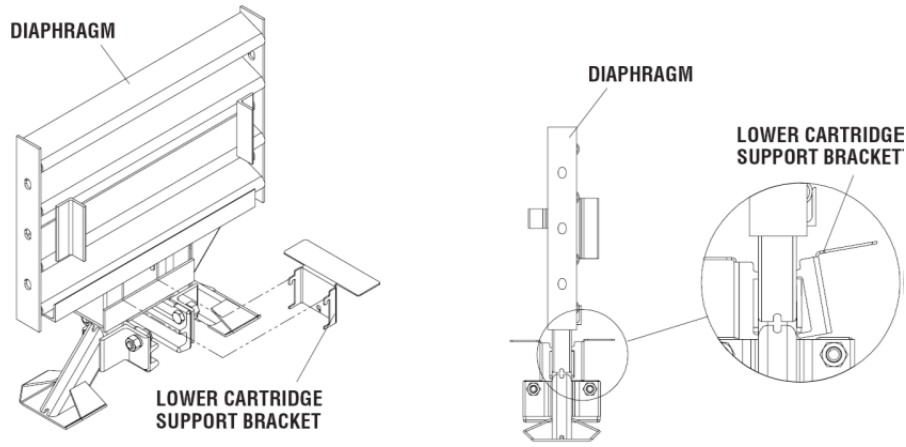

Figure 30
Lower Cartridge Support Bracket Assembly

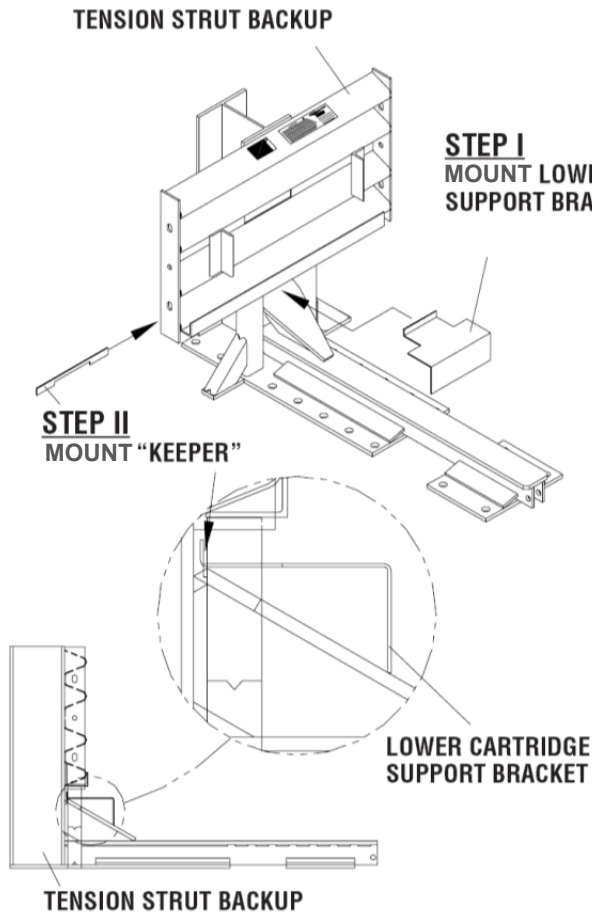

Figure 31
Lower Cartridge Support Bracket Assembly
(Tension Strut Backup)

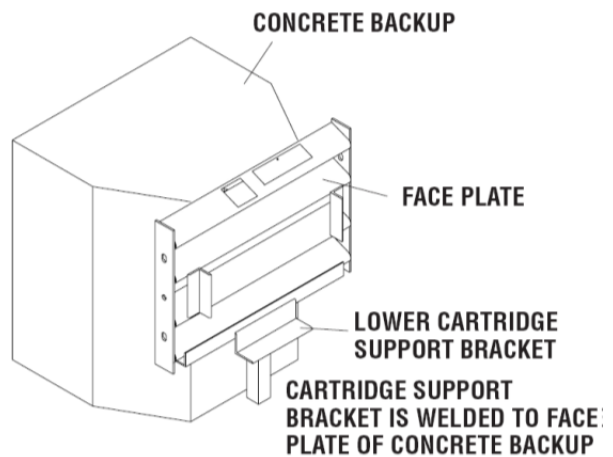

Figure 32
Lower Cartridge Support Bracket
(Concrete Backup)

11) Attach Nose Assembly

Bolt the Nose directly to the front Diaphragm, as shown in Figures 33a through 33c and the Nose Assembly drawing, using six threaded rods and four rail nuts per rod.

Place Pullout Brackets under center bolts.



Figure 33

1. Position a 5/8" Rail Nut 2-3/4" from the end of the 5/8" Threaded Rod. Tighten a second 5/8" Rail Nut against the first (See Figure 33a). Repeat this step for all six fasteners.

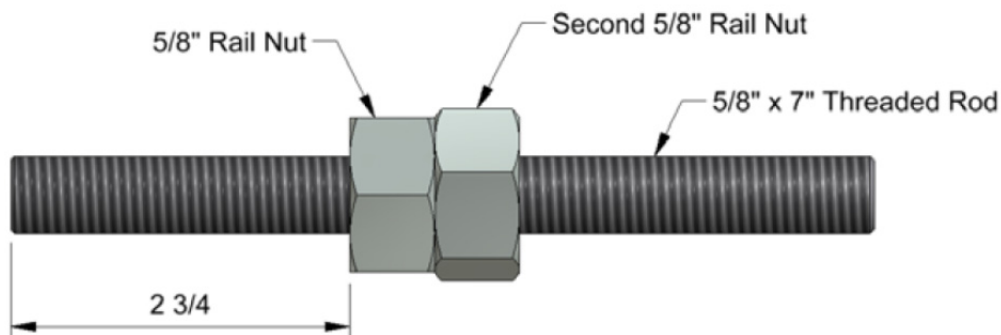

Detail 33a
Fastener Assembly

2. Using the fastener, assemble the Fender Panel to the Diaphragm. The 2 3/4" sections of threads should pass through the Diaphragm (See Figure 33b).
3. Position a 5/8" Rail Nut and washer flush with the outer edge of the Fender Panel (See Figure 33b). Repeat this step in all six locations.

4. Assemble the Nose Assembly to the QuadGuard II system using the 5/8" Rail Nuts and washer. Verify the 5/8" outward nut is flush with the Fender Panel (See Detail 33b). Adjust as necessary (See Figure 33 and 33c).

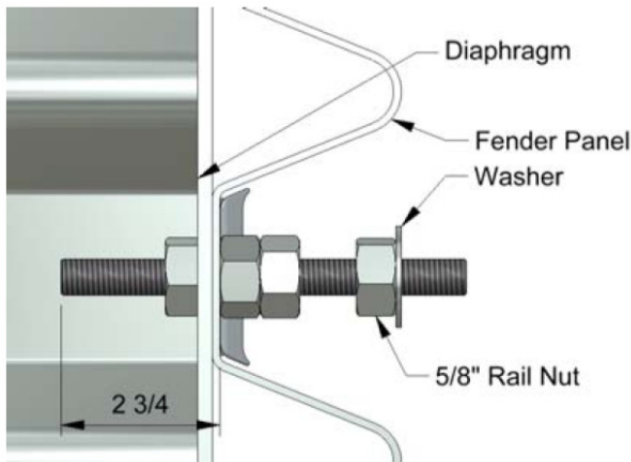

Detail 33b
End View with no Nose Cover

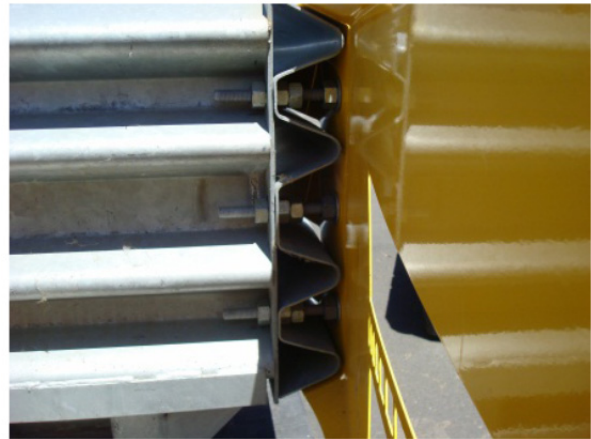

Detail 33c
End View With Nose Cover

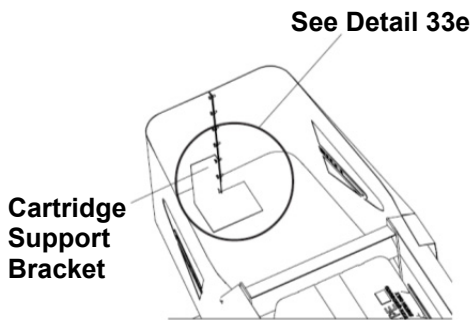

Detail 33d

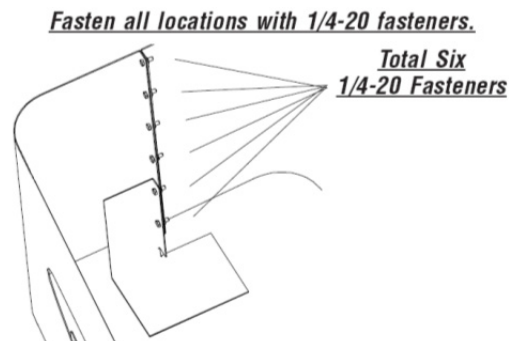

2701008-0000 BOLT,HX,1/4X3/4.G2,P
2708201-0000 WASHER,LOCK,3/4,G
2704151-0000 NUT,HX,1/4,G

Detail 33e

Detail 33e shows proper placement of front Cartridge Support Bracket.

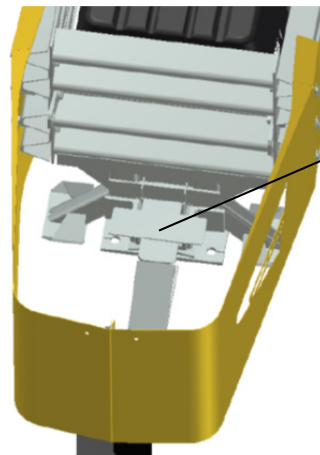

Note difference of front Diaphragm Bracket. The Cartridge sits lower on this Bracket than the Bays to the rear.

Detail 33g

12) Checking the System Assembly

At this point recheck to ensure that all fasteners are properly tightened throughout the system (anchor bolts, etc.). See warning below. Check all Fender Panels. If they do not fit tightly against the underlying Panel, system realignment may be necessary (See Figure 34).



Warning:	
Anchor Studs	Torqued to 165 N-m [120 ft-lb] Should NOT protrude above nuts (See Figure 18, page 19)
All Other Bolts	Tightened
Fender Panel	Maximum gap allowed: Narrow Systems – 20 mm [0.78"]

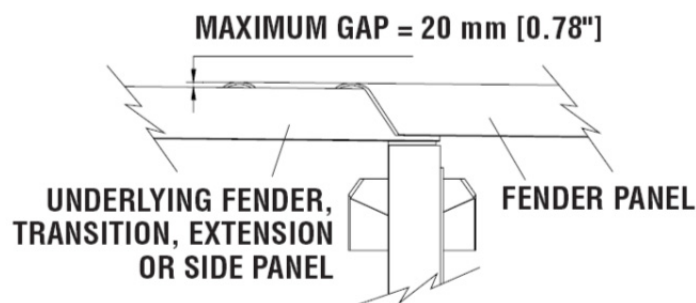

Figure 34
Fender Panel Gap for Narrow Systems

13) Cartridge Assembly

Be sure the Adjustable Cartridge Support in the Nose is attached correctly. See “Attach Nose Assembly” in Step 11 on Page 28. The top surface of the Nose Cartridge should be horizontal.

To complete the assembly of a QuadGuard® II system, place the appropriate Cartridge in each Bay and Nose section of the system. Type 1 Cartridges are placed toward the front (Nose) of the system; Type 2 Cartridges are placed toward the rear (Backup) of the system (See Figures 35 and 36).



Warning: Placing the wrong Cartridge in the Nose or any Bay has not been crash tested pursuant to the NCHRP 350 criteria. Accordingly, this is likely to result in unacceptable crash performance as described in NCHRP 350.

I - TYPE I CARTRIDGE
II - TYPE II CARTRIDGE

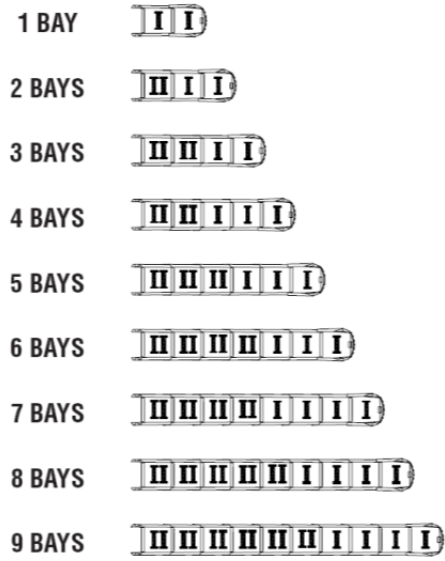

Figure 35
Cartridge Placement

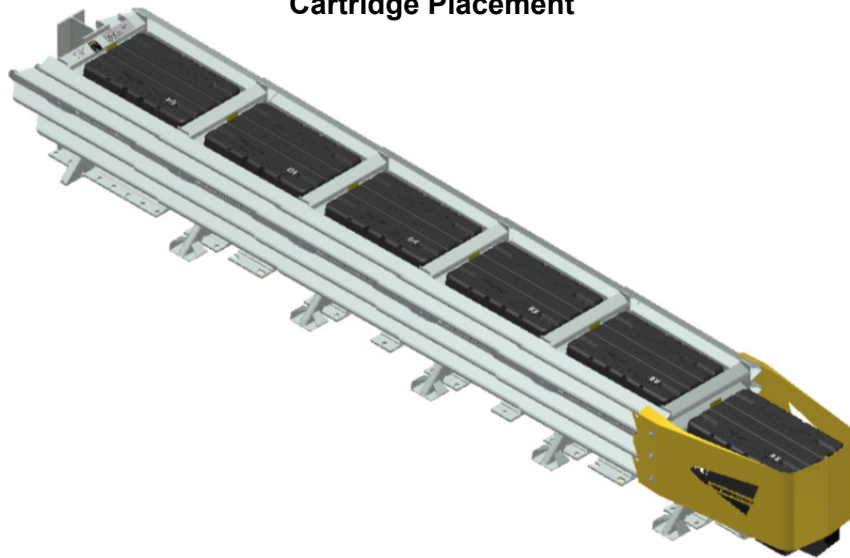
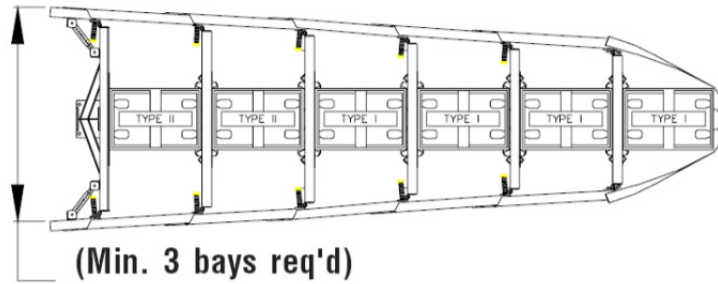

Figure 36
Typical Cartridge Layout 5 Bay System Shown

System Assembly for Wide Hazards



(Min. 3 bays req'd)

1755 mm [69"] MODEL NO. QG2_ _69

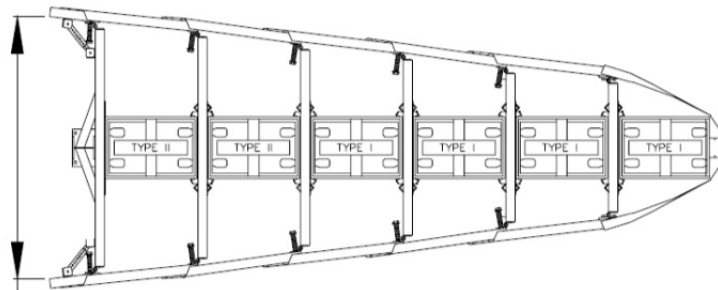

(Min. 3 bays req'd) 2285 mm [90"]

MODEL NO. QG2_ _90

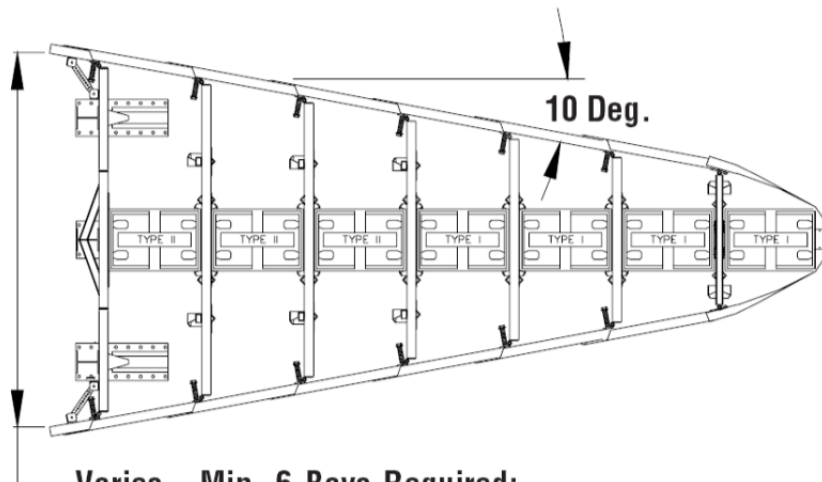

Varies - Min. 6 Bays Required:

3200 mm [126"] MODEL NO. QG2100126

Figure 37
Wide Systems and Model Numbers

Site Preparation/Foundation

A QuadGuard® II system should be constructed only on an existing or freshly placed and cured concrete base (28 MPa [4000 psi] minimum). Location and orientation of the concrete base and attenuator must comply with project plans or as otherwise determined by the resident project engineer.

Recommended dimension and reinforcement specifications for new concrete foundations are provided in Energy Absorption Systems concrete foundation drawings, supplied with the system. The system may be assembled on a non-reinforced concrete roadway (minimum 200 mm [8"] thick). Deployment cross-slope shall not exceed 8% and should not twist more than 2% over the length of the system; the foundation surface shall have a light broom finish.



Caution: Accurate placement of all steel rebar is critical to avoid interference with the concrete anchor bolts.



Warning: Location of the Backup in relation to nearby objects will affect the operation of the attenuator. Upon impact, the Fender Panels telescope rearward and extend beyond the rigid Backup as much as 876.3 mm [34.5"] from their pre-impact location. Position the Backup so that the rear ends of the last Fender Panels are a minimum of 760 mm [30"] forward of objects that would otherwise interfere with movement of the rearmost Fender Panels. Failure to comply with this requirement is likely to result in system performance which has not been crash tested pursuant to NCHRP 350 criteria and may also cause component damage which will necessitate maintenance or replacement of the system.

Inspect Shipping

Before deploying the QuadGuard® II system, check the received parts against the shipping list supplied with system. Make sure all the parts have been received.

Assembly Procedures

Note: The Drawing Package supplied with the QuadGuard® II system must be used with these instructions for proper assembly and should take precedence over these general instructions.

1) Determine Backup and Transition Type

The QuadGuard® II is available with a Tension Strut Backup or a Concrete Backup. See Figures 38 and 39, along with the Backup assembly drawing, to determine which type of Backup is being deployed.

A Transition Panel or Side Panel must be used on each side of the Backup. A Side Panel is not needed when a Transition Panel is used. Several types of transitions are available for use with the QuadGuard® II system. See Figures 40 through 45 and the drawing package to determine which types of panels to attach.

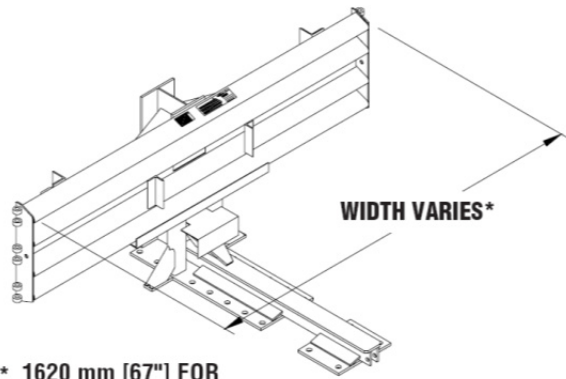

- * 1620 mm [67"] FOR
1755 mm [69"] WIDE SYSTEM
- * 2100 mm [83"] FOR
2285 mm [90"] WIDE SYSTEM
- * 3050 mm [120"] FOR
3200 mm [126"] WIDE SYSTEM

Figure 38
Tension Strut Backup

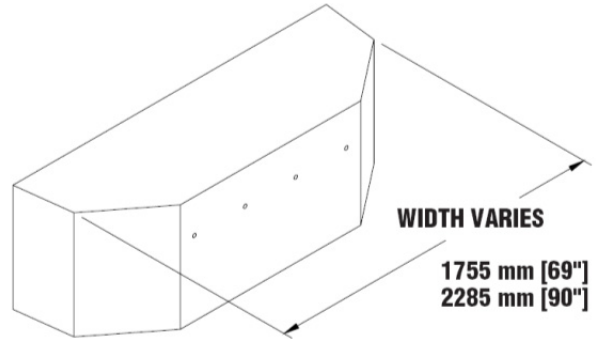

Figure 39
Concrete Backup

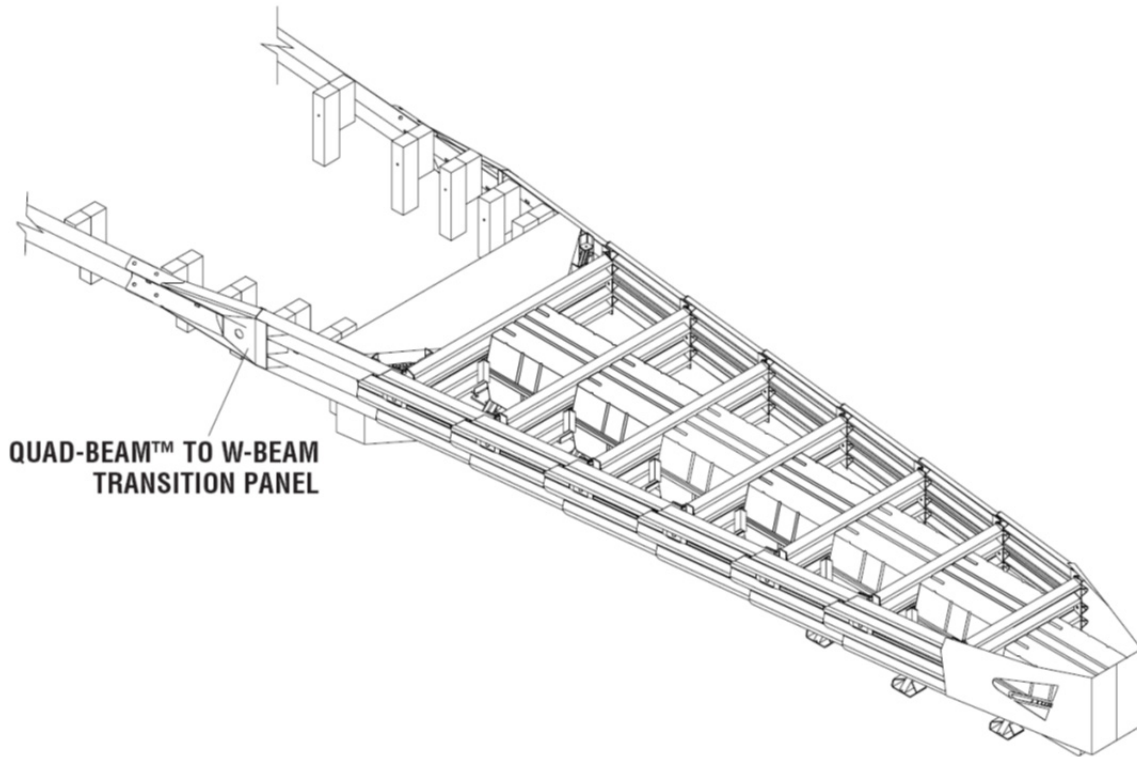

Figure 40
Transitioning the QuadGuard® II System

Transition Panel Types

Note: The proper Transition Panel or Side Panel must be used to perform as crash tested. The correct Panel(s) to use will depend on the direction of traffic and what type of barrier or hazard the QuadGuard® II system is shielding (See Page 16). Contact the Customer Service Department prior to deployment if you have any questions.

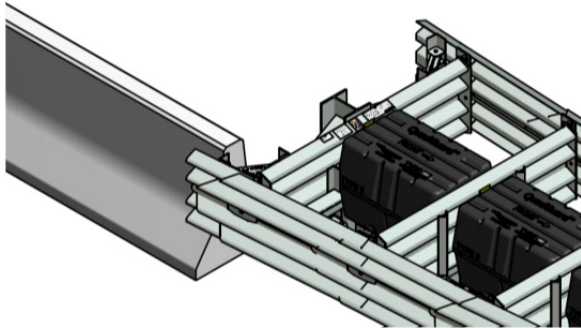

Figure 41
No Transition

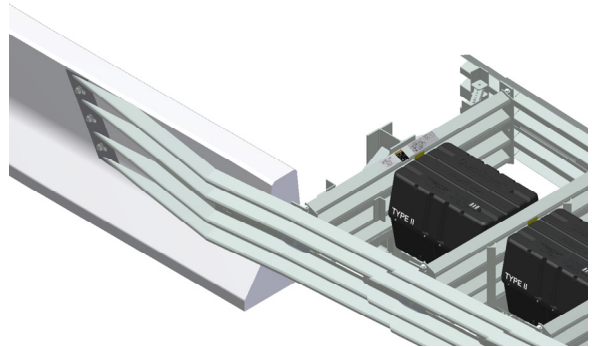

Figure 42
Quad-Beam™ to Safety Shape Barrier

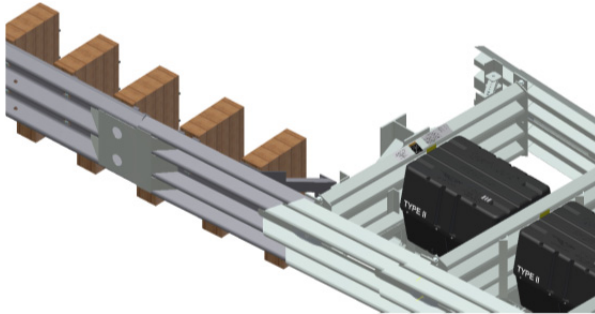

Figure 43
Quad-Beam™ to Thrie-Beam

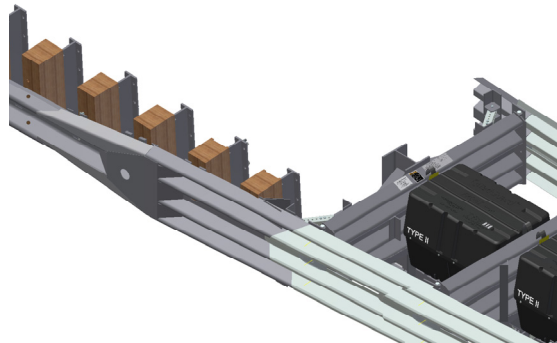

Figure 44
Quad-Beam™ to W-Beam

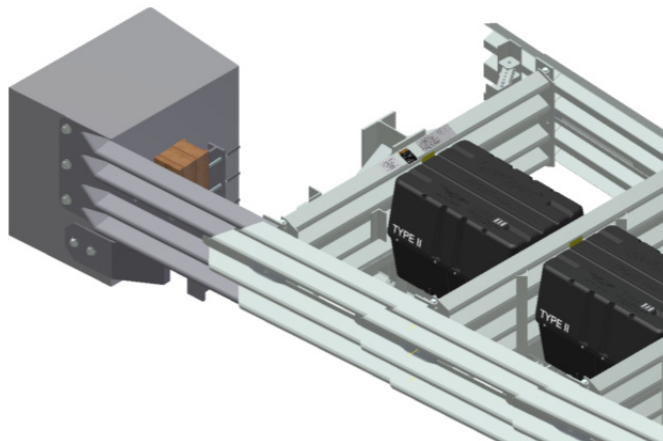

Figure 45
Quad-Beam™ End Shoe

2) Mark System Location

Locate the centerline of the system by measuring the proper offset from the hazard. See the Drawing Package supplied with the system. Place chalk line to mark the centerline of the system. Mark a construction line parallel to the center line and offset 165 mm [6.5"] to one side as shown in Figure 46. The edge of the Monorail will be placed on this line.

Note: The concrete foundation shall comply with the project plans supplied with the system.



Warning: Location of system with respect to the hazard is critical and dependent on the type of Transition Panel used. See the Project Plans supplied with the system for details.



Figure 46
(Top view of concrete foundation)

3) Anchor the Backup

A) Concrete Backup Construction (Figure 47)

Locate Backup Face Plate using the Backup assembly drawing. Drill anchor holes in the Concrete Backup using the Face Plate as a template. Anchor the Face Plate to the Concrete Backup using the MP-3[®] Anchoring system (horizontal kit) supplied with the QuadGuard[®] II system (See "MP-3[®] Polyester Anchoring System" section on Page 51).



Warning: Every hole and slot in Backup and Monorail must have an MP-3[®] stud anchoring it.

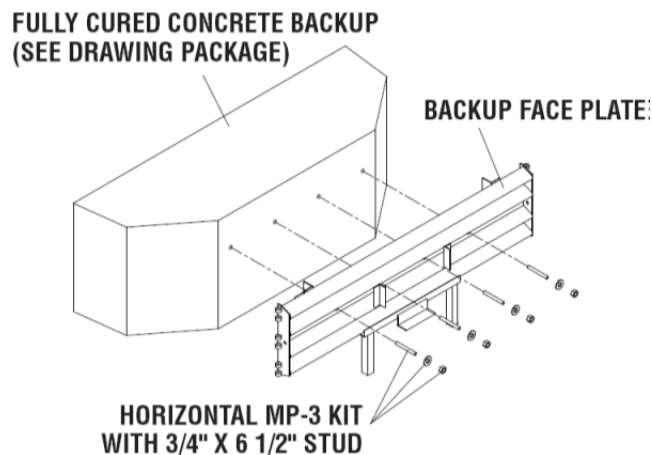

Figure 47
Anchoring Backup Face Plate to Concrete Backup

B) Tension Strut Backup Assembly

Locate the Tension Strut Backup and Monorail on foundation with side of Monorail on the construction line (See Figure 52 on Page 39). Verify that any applicable Transition Panels fit properly before anchoring Backup. Drill anchor holes in foundation using the Backup as template. Anchor the Backup to the concrete foundation using the MP-3[®] Anchoring System (vertical kit) supplied with the QuadGuard[®] II system (See "MP-3[®] Polyester Anchoring System" section on Page 51).



Caution: Every hole and slot in Backup and Monorail must be anchored by an MP-3[®] stud.

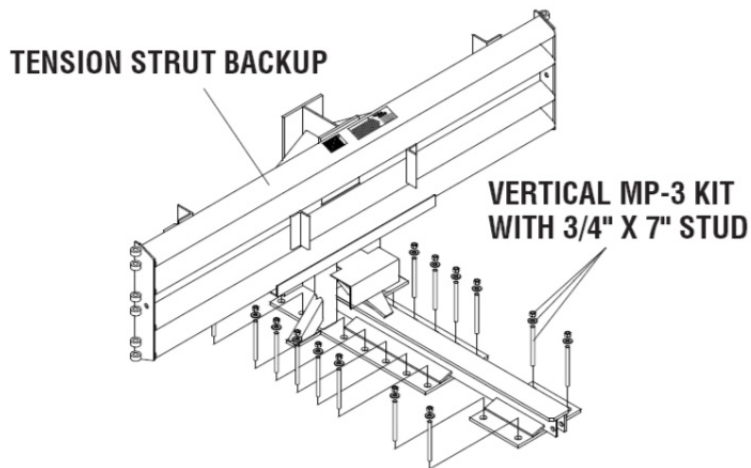

Figure 48
Anchoring Tension Strut Backup to Foundation

C) Extra-Wide Tension Strut Backup Assembly (Figure 49)

Locate the Extra-Wide Tension Strut Backup center section and Monorail on foundation with side of Monorail on the construction line (See Figure 52 on Page 39).

Locate the Extra-Wide Tension Strut Backup left section on the left side of the center section, aligning the three holes in the side plates.

Locate the Extra-Wide Tension Strut Backup right section on the right side of the center section, aligning the three holes in the side plates.

Secure the Backup sections to each other using 5/8" x 2" hex bolt, 5/8" x 1 3/4" flat washer (2), 5/8" lock washer and 5/8" hex nut (6 places) as shown in Figure 49 and Detail 49a.

Verify that any applicable Transition Panels fit properly before anchoring Backup. Drill anchor holes in foundation using the Backup as template. Anchor the Backup to the foundation using the MP-3[®] vertical kits supplied with the QuadGuard[®] II system (See "MP-3[®] Polyester Anchoring System" on Page 51).



Warning: Every hole and slot in Backup and Monorail must be anchored by an MP-3[®] stud.

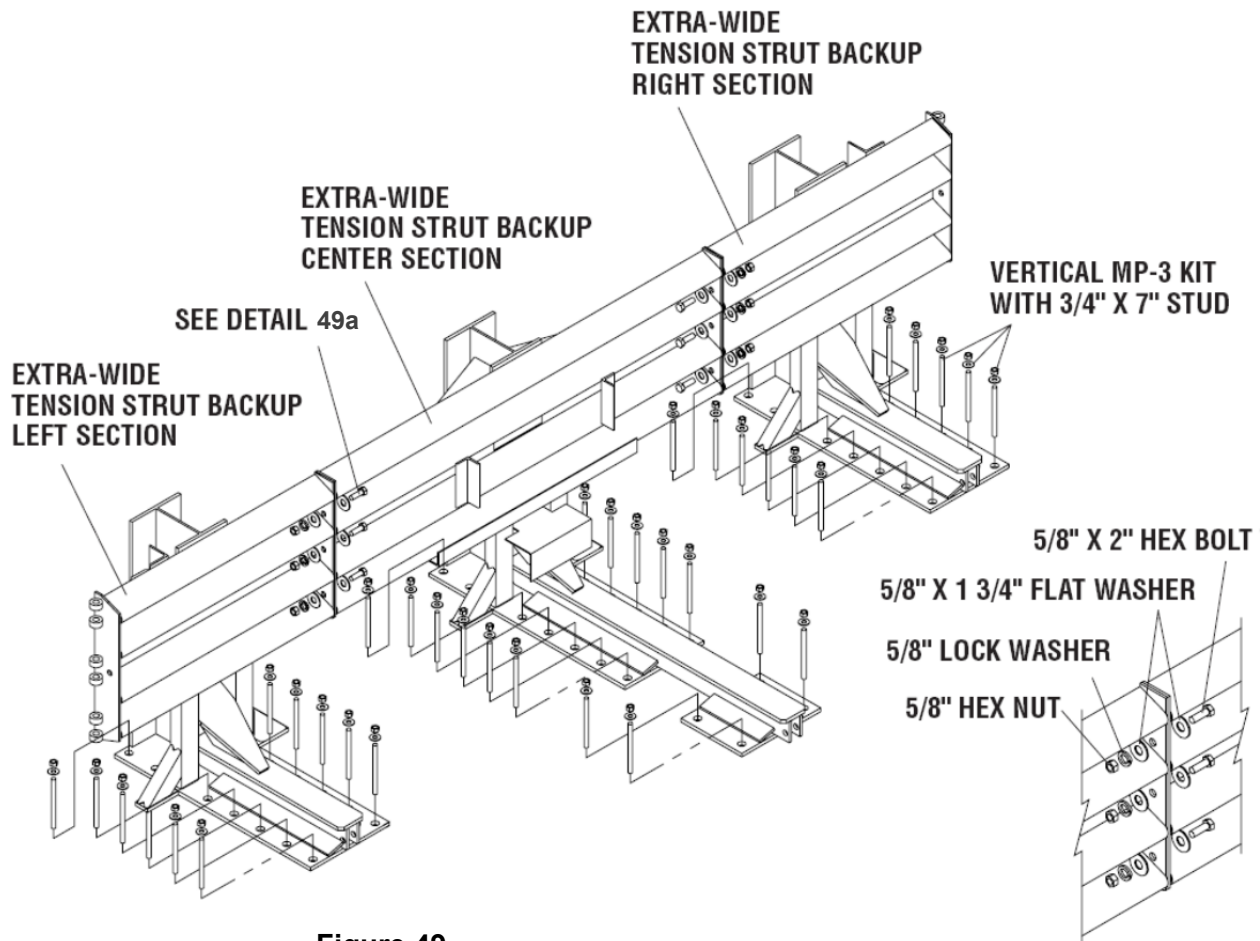

Figure 49
Anchoring Extra-Wide Tension Strut Backup to Foundation See Drawing Package

Detail 49a

4) Anchor the Monorail

A) Monorail Construction for Concrete Backup (See Figure 51).

Locate Monorail on foundation with side of Monorail on the construction line and rear edge of Monorail 10" forward of front face of Concrete Backup (See Figure 51).

Orient the Monorail so that the Monorail tongues face Backup (See Figure 51).

Drill 140 mm [5 1/2"] deep anchor holes using the Monorail as a template. Do not drill through foundation.



Warning: Improper alignment at the Monorail Splice Joints may prevent proper system collapse during an impact.



Warning: Every hole and slot in Backup and Monorail must be anchored by an MP-3[®] stud.

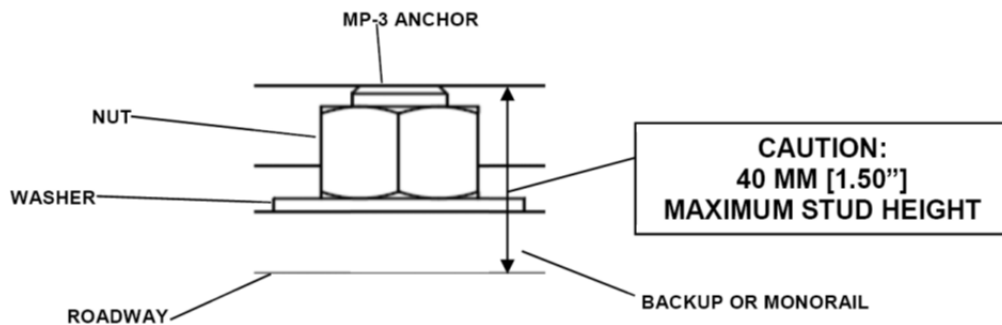

Figure 50
Proper Stud Height

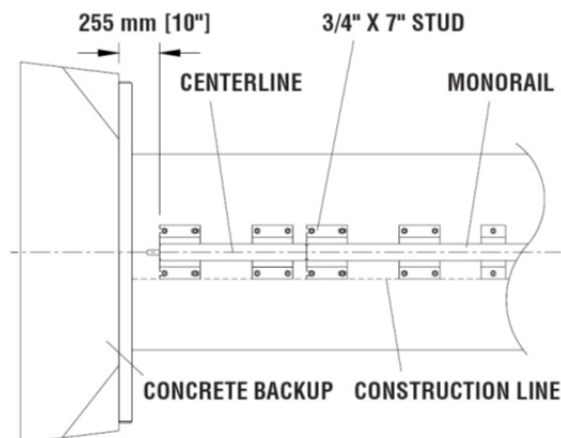

Figure 51
Monorail Location for Concrete Backup

B) Monorail Construction for Tension Strut Backup (See Figure 52).

Locate Monorail on foundation with side of Monorail on the construction line and rear edge of Backup 4" forward of edge of foundation (See Figure 52).

Orient the Monorail so that the Monorail tongues face the Backup (See Figure 52).

Drill 140 mm [5 1/2"] deep anchor holes using the Monorail as a template. Do not drill through foundation.

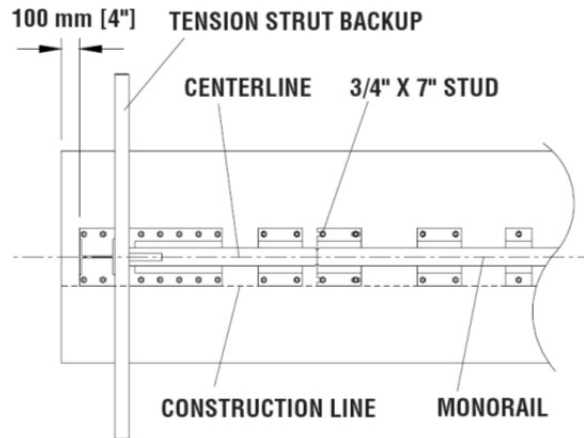

Figure 52
Backup and Monorail Location for Tension Strut Backup

5) Attach Side Panels and/or Transition Panels to Backup Assembly

- Attach Hinge Plate to the Transition Panel or Side Panel using 5/8" rail bolt and 5/8" rail nut (two places – top and bottom holes only).
- Attach Transition Panel or Side Panel assembly to side of Backup using 5/8" hex bolt, 5/8" lock washer and 5/8" hex nut (three places each side of Backup). See illustration on Page 41.
- Attach diagonal brace to Fender Panel and Backup using 3/8" hex bolt, 3/8" lock washer and 3/8" hex nut (two places per brace: 4 places per side).
- Secure each diagonal brace with a 3/8" hex bolt; 3/8" lock washer, and 3/8" hex nut (two places per brace) as shown in Figure 53.

Note: A Side Panel is not needed when a Transition Panel is used. Diagonal braces not used with some Transition Panels (See drawing package).

Assembly tip:

Use drift pin to align the center hole of the Panel with the center hole of the Backup before attaching the rail bolts.

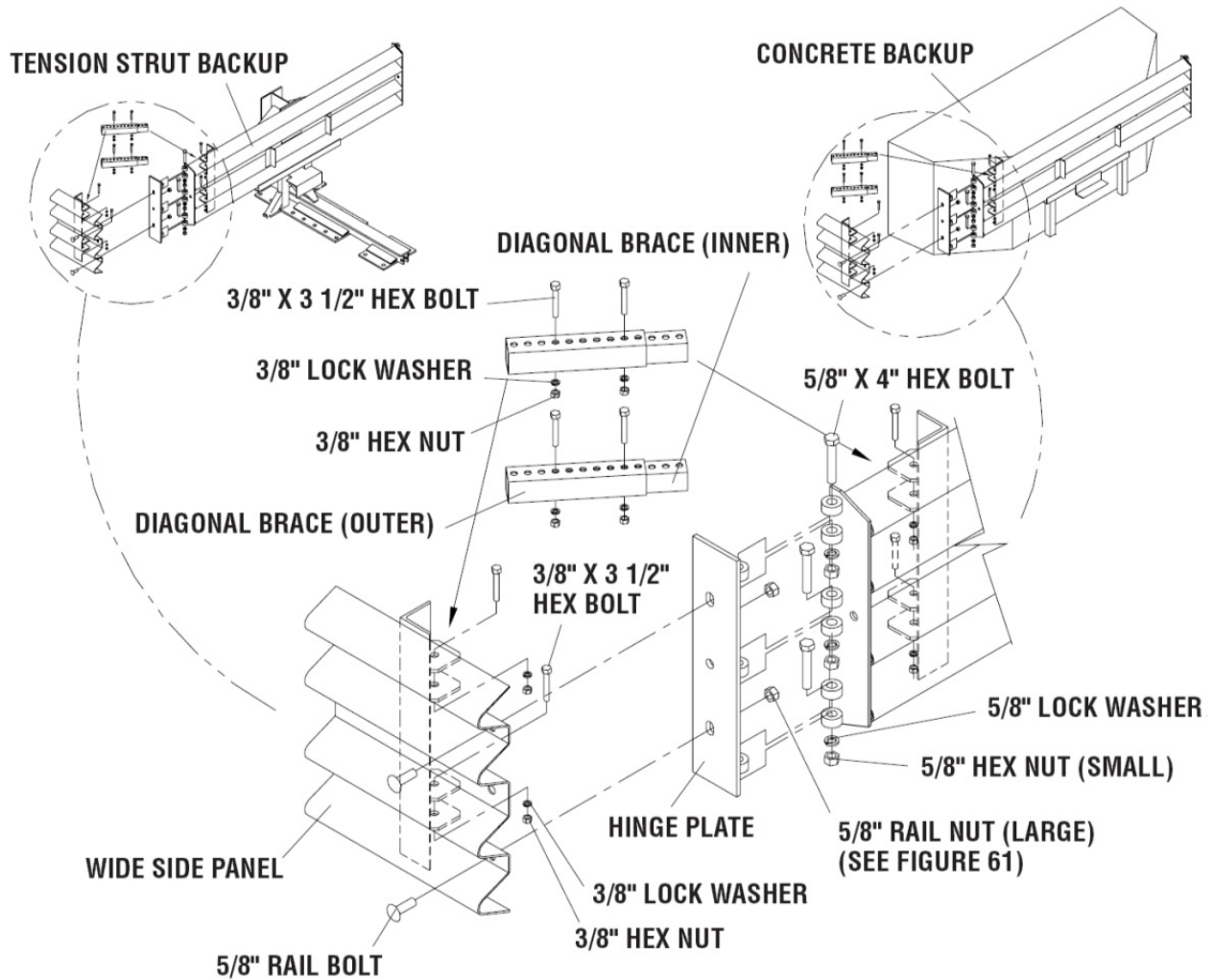

Figure 53
Side Panel/Transition Panel Attachment

6) Attach Monorail Guides

Attach Monorail guides to Diaphragm as follows:

Insert 3/4" x 2" G8 hex bolt through Monorail guide and Diaphragm, oriented as shown in Figure 54. Secure with 3/4" lock washer and 3/4" hex nut (typical two places per guide). See also Diaphragm assembly drawing. Shims are sandwiched between Monorail guides and Diaphragm.

Repeat process for each Diaphragm.

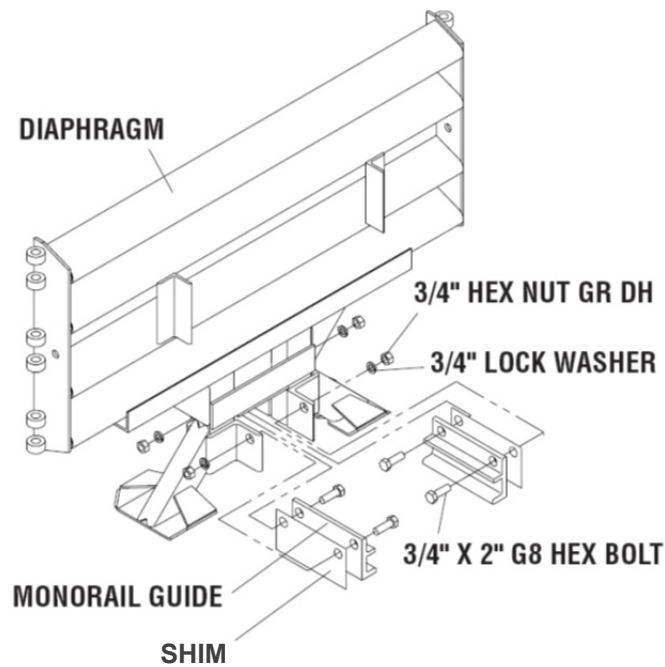

Figure 54
Monorail Guide Attachment

7) Attach Diaphragms

Orient the widest Diaphragm so that the front face of the Diaphragm shape faces toward the Nose of the system as shown in Figure 55. **The widest Diaphragm must be attached closest to the Backup with each subsequent Diaphragm being progressively narrower.**

Slide the widest Diaphragm onto the Monorail and all the way to the Backup to ensure system is able to collapse properly during impact. Once this has been verified, slide the Diaphragm forward to approximately 915 mm [36"] in front of the Backup.

Orient and slide all other Diaphragms onto Monorail and position each approximately as shown in Figure 56.

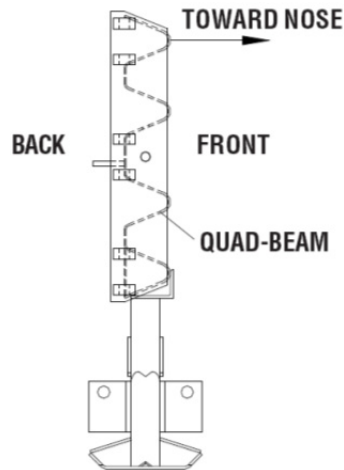

Figure 55
Diaphragm Orientation

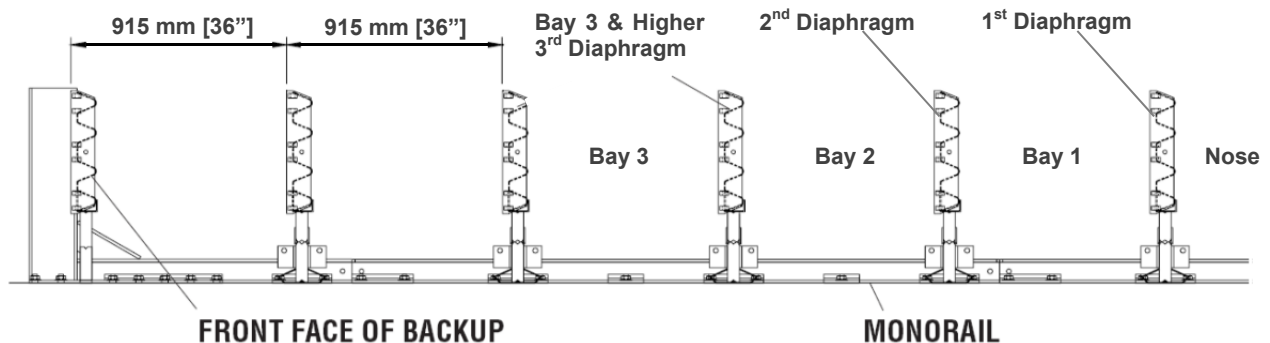

Figure 56
Diaphragm spacing

8) Attach Hinge Plate onto Fender Panels

Note: Do not mix the 5/8" rail nuts (large) with the 5/8" hex nuts (small).

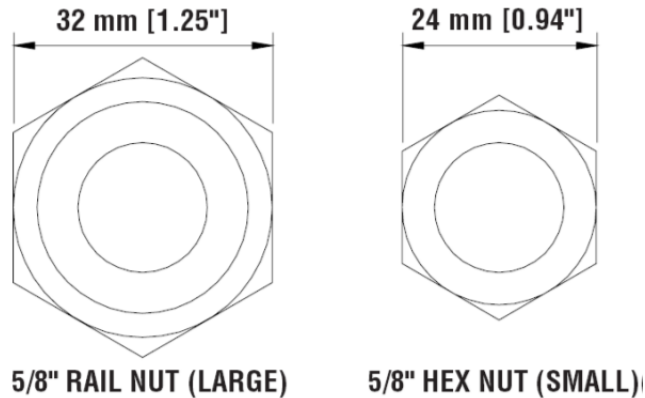

Figure 57
Rail Nuts are Oversize

Note: For proper impact performance, Systems for wide hazards must have Hinge Plates.

Attach Hinge Plate on each Fender Panel using two 5/8" rail bolts and two 5/8" rail nuts, using top and bottom holes only, leaving the center-hole open as shown in Figure 58.

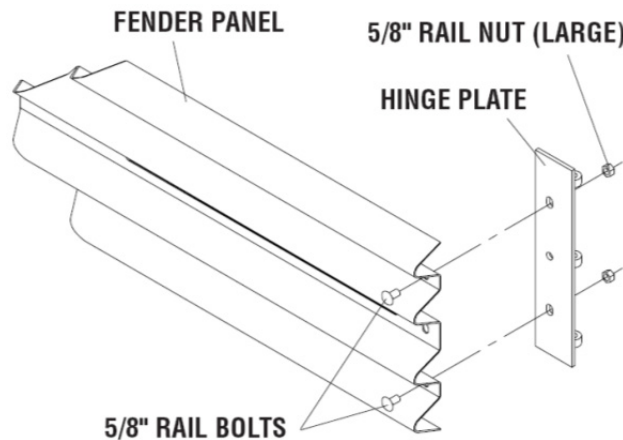

Figure 58
Hinge Plate Assembly

9) Attach Fender Panels

Starting at the Backup, attach left and right Fender Panels as shown in Figure 59.

Attach Mushroom Washer Assembly as shown in Figure 59 and Detail 59a but do not torque at this time.

Step 1

Place the Fender Panel so that the center of the slot of the rearward Diaphragm is lined up with the approximate center of the slot in the Fender Panel.

Attach Mushroom Washer Assembly as shown in Figure 59 and Detail 59a and Detail 59b and do not torque at this time. This (Step 1) helps to balance the Fender Panel.

Step 2

Slide the Fender Panel forward until the holes in the Fender Panel line up with the holes in the forward Diaphragm.

Step 3

Use a drift pin to align the center hole of the Fender Panel with the center hole of the Diaphragm.

Step 4

Attach the front of the Fender Panels to the next Diaphragm using 5/8" x 4" bolts, 5/8" lock washer and 5/8" hex nut (small) in three places on the Hinge Plate per side.

Step 5

Be sure Mushroom Washer lays flat against the Fender Panel as shown in Detail 59a. Standoff on Mushroom Washer must be seated completely through slot.

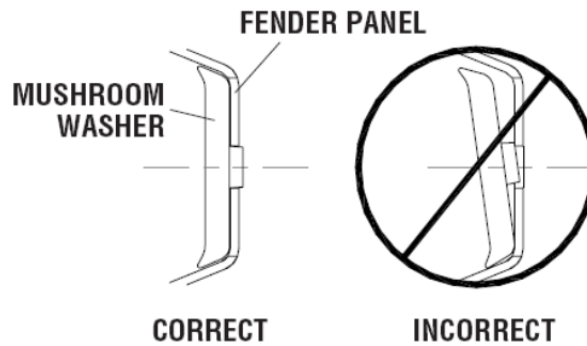

**Detail 59a
Mushroom Washer Orientation**

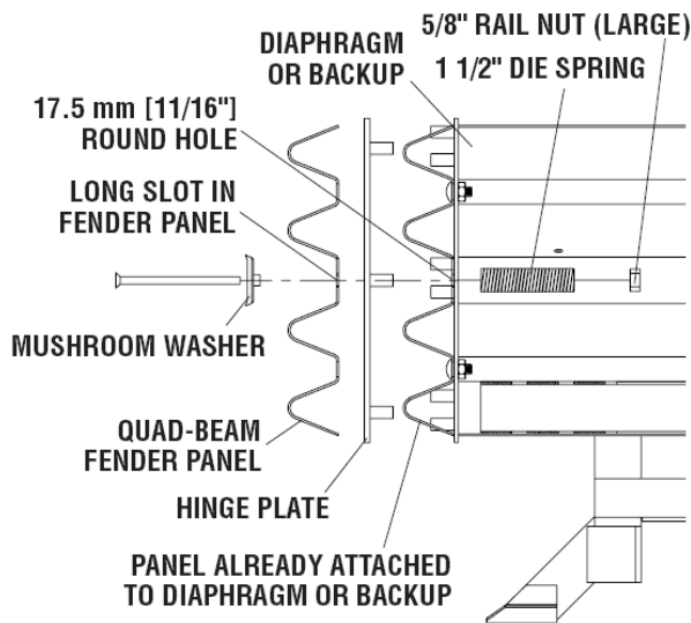

**Figure 59
Mushroom Washer Attachment**

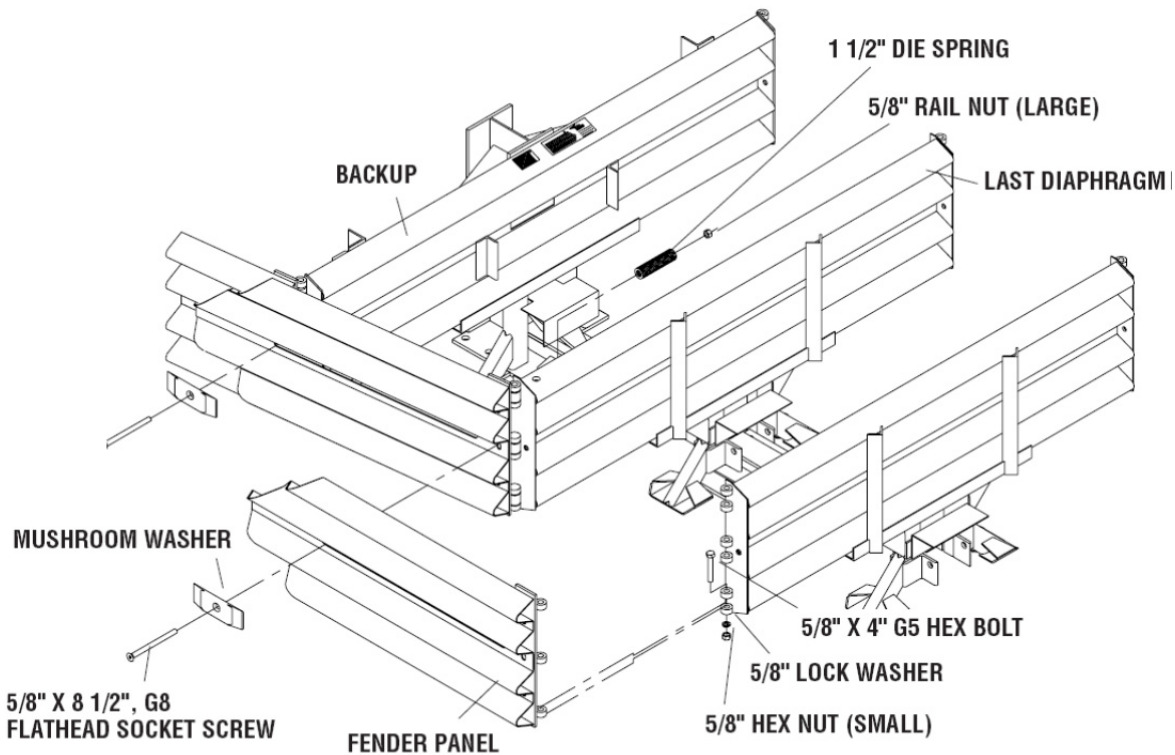

Figure 60
Fender Panel Assembly

Step 6

Check Diaphragm spacing to endure 915 mm [36"] between rear faces of consecutive Diaphragms as shown in Figure 61 and Fender Panel Assembly drawing.

Step 7

Once the proper spacing has been achieved, torque the Mushroom Washer Assembly (small hex nut) until it reaches the end of the threads. Assemble the remaining Diaphragms and Fender Panels following the same procedures.

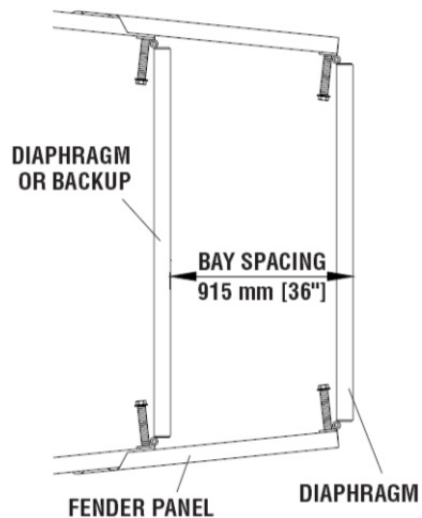

Figure 61
Proper Spacing Between Diaphragms

10) Attach End Cap

Using 5/8" x 3 1/2" G5 hex bolt, 5/8" hex nut and 5/8" lock washer, attach the End Cap to the front of the first Monorail segment as shown in Figure 62 and the Monorail Assembly drawing.

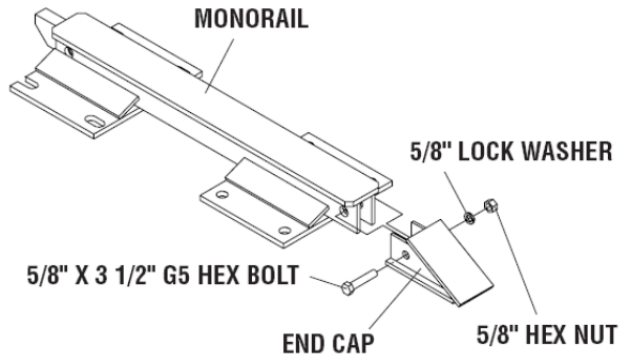

Figure 62
Monorail End Cap Assembly

11) Assemble Cartridge Support Brackets

Attach Cartridge Support Bracket to all Diaphragms and Backup as shown in Figures 63 - 66, the Backup Assembly drawing, and the Diaphragm Assembly drawing.

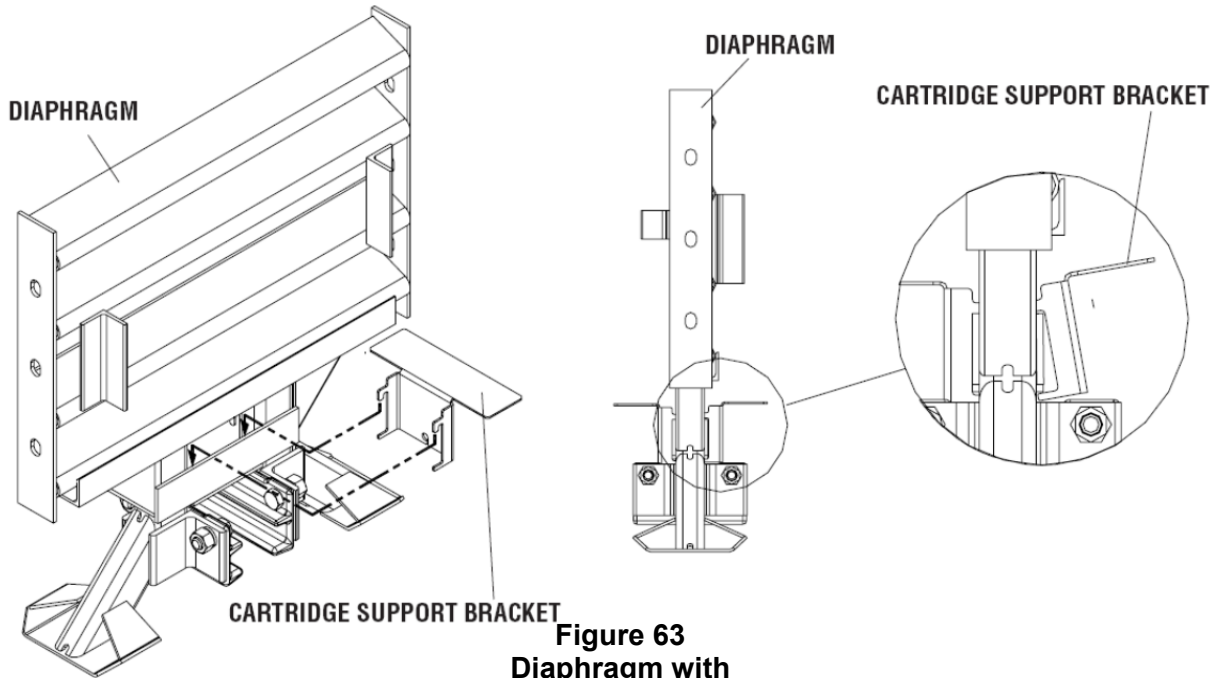

Figure 63
Diaphragm with
Cartridge Support Bracket

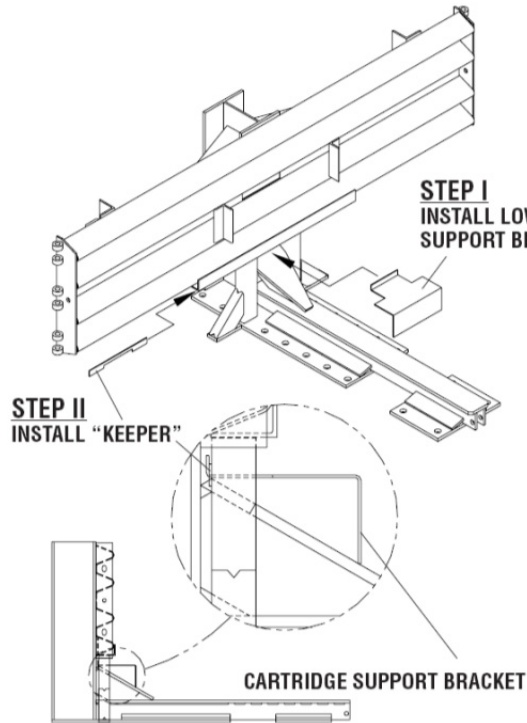

Figure 64
Cartridge Support Bracket
(Tension Strut Backup)

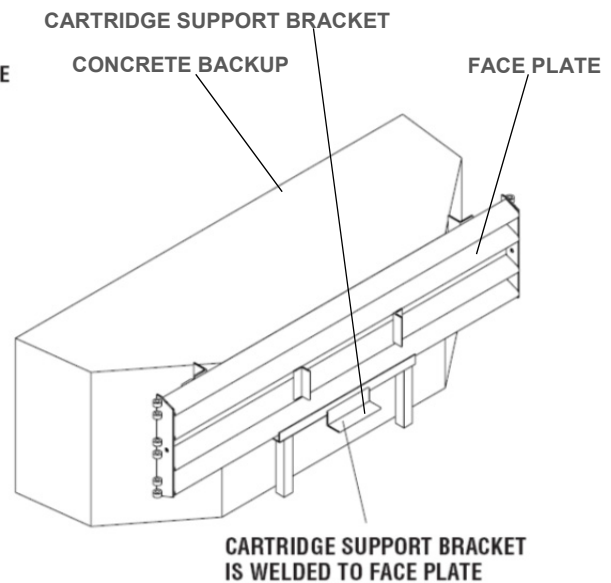

Figure 65
Cartridge Support Bracket
(Concrete Backup)

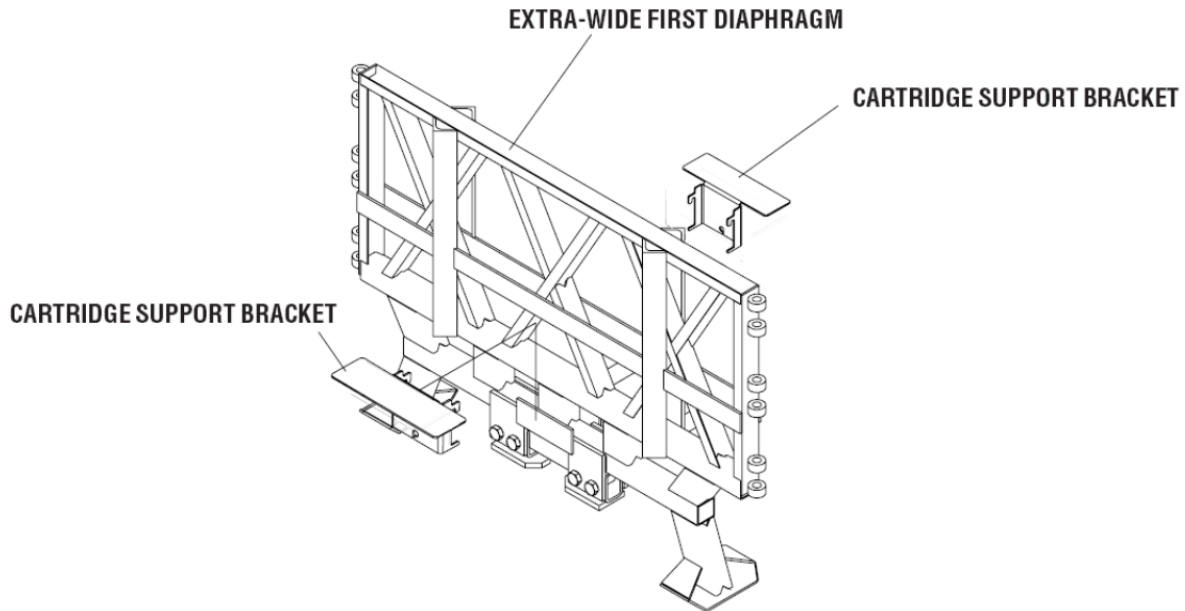

Figure 66
Extra-Wide First Diaphragm With Cartridge Support Bracket
 (See Drawing Package)

12) Attach Nose Assembly

(See Pages 28 and 29 for Nose Assembly instructions.)

13) Checking the System Assembly

At this point recheck to ensure that all fasteners are properly tightened throughout the system (anchor bolts, etc.). See warning below. Check all Fender Panels. If they do not fit tightly against the underlying Fender Panels, system realignment may be necessary (See Figure 67).



Warning:	
Anchor Studs	Torqued to 165 N-m [120 ft-lb] Should NOT protrude above nuts (See Figure 18 on Page 19).
All Other Bolts	Tightened
Fender Panel	Maximum Gap Allowed: Wide Systems – 25 mm [1.00”]

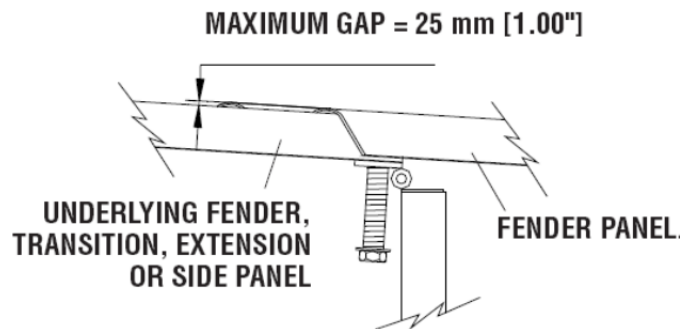

Figure 67
Fender Panel Gap for Wide Systems

14) Cartridge Attachment

Be sure the Adjustable Cartridge Support in the Nose is attached correctly. See “Attach Nose Assembly” in Step 11 on Page 28. The top surface of the Nose Cartridge should be horizontal.

To complete the assembly of a QuadGuard® II system, place the appropriate Cartridge in each Bay and Nose section of the system. Type I Cartridges are placed toward the front (Nose) of the system; Type II Cartridges are placed toward the rear (Backup) of the system (See Figures 68 and 69).



Warning: Placing the wrong Cartridge in the Nose or any Bay may result in unacceptable crash performance as describe in NCHRP Report 350 as other configurations have not been crash tested.

I - TYPE I CARTRIDGE
II - TYPE II CARTRIDGE

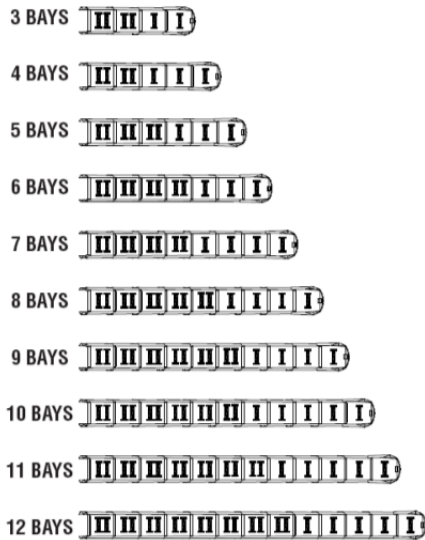

Figure 68
Cartridge Placement

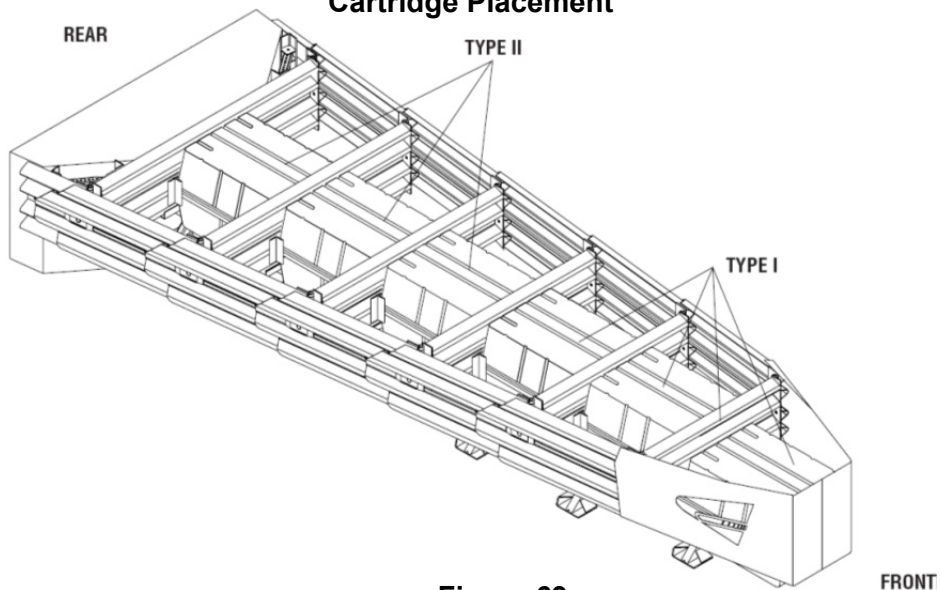

Figure 69
Typical Cartridge Layout (5 Bay System Shown)

MP-3[®] Polyester Anchoring system

The MP-3[®] Polyester Anchoring System is a quick and easy way to securely anchor crash cushions and other common highway devices. MP-3[®] features high pullout strength, superior vibration resistance, and exceptional durability.

Each MP-3[®] kit contains a can of MP-3[®] resin, hardener, cold weather promoter, studs, and washers. The cold weather promoter shortens hardening time by as much as seven hours. Both vertical and horizontal assemblies are possible using the MP-3[®] system.

Vertical Assemblies

Note: Read MP-3[®] Instructions before starting.

1) Prepare the Concrete Foundation



Warning: Do not allow the MP-3[®] resin or hardener to contact skin or eyes. See material safety data sheet supplied with the MP-3[®] kit for first-aid procedures. Use only in well-ventilated area. Do not use near open flame.



Warning: Wear safety goggles, apron, and gloves during construction.

The anchor bolts (studs) that anchor the QuadGuard[®] II system Backup and/or Monorail sections to the concrete foundation must be those shipped in the kit or of high strength steel (830 MPa [120,000 psi] minimum tensile strength or equal). These studs must be set in minimum 28 MPa [4000 psi] concrete. Allow the concrete to cure a minimum of seven days before applying MP-3[®].

2) Drill Holes

Note: Energy Absorption Systems recommends using two fluted drills to achieve optimum tensile strength when applying the MP-3[®] anchoring system.

Use the part that is to be anchored as a drilling template. Drill the holes 3 mm [1/8"] larger than the stud diameter to the recommended depth, using a rotary percussive drill. If a diamond drill is used, the surface will be too smooth for the MP-3[®] to adhere and full strength will not be achieved. See the MP-3[®] assembly instructions provided with your kit. Check to be sure all the holes are drilled to the proper depth and aligned with the part to be anchored (See Table A).

Table A
MP-3[®] Anchoring Information

Stud Size:	Concrete Bit Size	Minimum Depth	Recommended Torque
3/4"x 6 1/2"	22 mm [7/8"]	125 mm [5"]	165 N-m [120 ft-lb]
3/4"x 7"	22 mm [7/8"]	140 mm [5" 1/2"]	165 N-m [120 ft-lb]
3/4"x 18"	22 mm [7/8"]	420 mm [16 1/2"]	<15 N-m [<10 ft-lb]

3) Clean the Holes

Blow the concrete dust from the hole using oil-free compressed air. Thoroughly brush it with a stiff-bristled brush and then blow it out again. If the hole is wet, completely flush it with water while brushing. Then blow it clean using oil-free compressed air.

4) Mix the Resin and Hardener

Wearing gloves, apron and safety goggles, remove the lids from the MP-3[®] Part A-resin and Part B-hardener containers. Pour Part B into Part A, then mix vigorously for 30 seconds to form MP-3[®] grout (an anchor stud may serve as a stirring rod).

5) Add Cold Weather Promoter (in Cold Weather)

For faster hardening in cold weather, promoter may be used. Add the entire contents of the partially filled promoter container to the MP-3[®] grout, then mix for an additional 30 seconds. Use immediately because the MP-3[®] grout will thicken quickly. See Table B for hardening times.



Warning: Do not use promoter when the temperature is above 15 degrees Celsius (60 degrees Fahrenheit). Grout will harden too quickly. Use only in well-ventilated area. Do not use near open flame.

6) Pour Grout into Holes

Crimp the mouth of the can to form a sprout, and pour the MP-3[®] grout mixture down into the hole through the part. Fill the hole to 1/3 - 1/2 full.



Caution: Do not overfill or underfill the hole. If the hole is overfilled, there will not be enough grout to use all of the anchor studs/kit. If hole is underfilled, the grout may not develop the required pull out strength.

7) Add the Washers and Nuts

Place a flat washer onto the stud, then thread a nut on until **1 or 2 threads of the NUT** are left exposed.

8) Insert Studs in Holes and Wait for Grout to Harden

Push the stud down through the part to be anchored and into the hole. Give the stud several twists in the MP-3[®] to wet the threads.



Caution: Do not disturb or load the stud until the MP-3[®] material has hardened (See Table B).

9) Torque the Nuts

Once the grout has hardened, torque the nut to the recommended values (See Table A on Page 51).

Table B
Approximate Hardening Times (hours)

Temperature Concrete Bit Size		Hardening Times (hours) Recommended Torque	
(C)	(F)	No Promoter	With Promoter
>26	>80	1/2	N/R*
22-26	70-79	1	N/R
16-21	60-69	2	N/R
10-15	50-59	4	3/4
4-9	40-49	8	1
-1-3	30-39	N/R	1 1/2
<-1	<30	N/R	N/R**
*Not recommended			
**Contact Customer Service Department for more information			

Horizontal Assemblies

The horizontal MP-3[®] kit is the same as the vertical kit except that a Cartridge for a standard caulking gun is supplied in the horizontal kits and the resin for the horizontal kits is a thixotropic (TX) resin. The TX-Resin is a gelled resin intended to keep the grout in place in horizontal holes during application.

When using the horizontal MP-3[®] kits, follow the vertical instructions with the following exceptions:

1) Thread Dispensing Tip onto Dispenser

Prior to mixing the grout, carefully thread the dispensing tip onto the dispenser.

2) Pour Mixed Grout into Dispenser

Once the grout is mixed, crimp the mouth of the can to form a spout and pour the MP-3[®] grout into the open end of the dispenser (use mixing stud to scrape out the portion remaining in the can). You may use the box to hold the dispenser upright. Close the box lid and poke the dispenser tip into the top of it. Seal the dispenser with the plunger provided.

3) Place Dispenser in Caulking Gun and Dispense Grout

Cut the small end of the dispenser tip off. Place the dispenser into a caulking gun and dispense until MP-3[®] TX grout reaches the tip of the dispenser, then release pressure. Push the dispenser tip through the part to the bottom of the hole and dispense while slowly withdrawing the tip.



Caution: Do not over fill or under fill the hole. Fill hole approximately 1/3 to 1/2 full. If the hole is overfilled, there will not be enough grout to use all of the anchor studs/kit. If hole is underfilled the grout may not develop the required pull out strength.

4) Add the Washers and Nuts

Put washer and nut on stud leaving nut flush with end of stud (See Figure 70).

5) Insert Studs into Holes

Push stud through part to be anchored and into hole. Twist the stud in the MP-3[®] grout to wet the threads.

Note: In horizontal applications the stud should be flush with the top of the nut (See Figure 70).

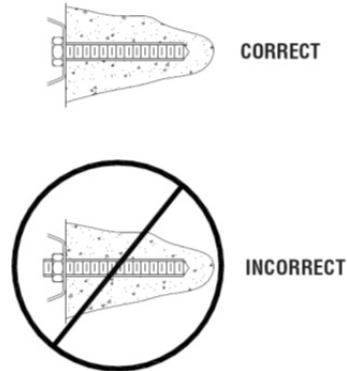

Figure 70
MP-3[®] Horizontal Application



Caution: Do not disturb or load the stud until the MP-3[®] material has hardened (See Table B for hardening times).

6) Torque the nuts

Once the grout has hardened, torque the nut to 165 N-m [120 ft-lb].

MP-3[®] Assembly Cautions

1) Shelf life

If the shelf life of the MP-3[®] has expired (See MP-3[®] kit for expiration information), mix a small amount of MP-3[®] in the proportions of one part A to two parts B by volume. If the material does not set according to the instructions, contact Energy Absorption Systems for guidance (See Page 3).



Warning: Do not use the MP-3[®] if: the material fails to set up, Part A-Resin had gelled (for vertical applications), or TX-Resin is NOT gelled (for horizontal applications).

2) Steel rebar

If steel rebar is encountered while drilling an MP-3[®] anchor bolt hole, apply one of the following solutions:

- A) Using a diamond core drill or rebar drilling tool, drill through the rebar only, then switch back to the concrete bit and drill into the underlying concrete until the proper hole depth is reached.



Caution: Do not drill through rebar without first obtaining permission to do so from the local project engineer.

- B) Drill a new hole down at an angle past the rebar to the proper depth. Anchor the stud by completely filling both holes with MP-3[®].

Maintenance and Repair

Inspection Frequency

Inspections are recommended as needed based upon volume of traffic and impact history. Visual Drive-By Inspections are recommended at least once a month. Walk-Up Inspections are recommended at least once a year for QuadGuard® II systems on asphalt.

Visual Drive-By Inspection

- 1) Check to see if there is evidence of a hit. If so, a walk-up inspection will be necessary.
- 2) Check to see if the Cartridges appear to be off the Support Brackets. Any damaged Cartridges will need to be replaced.



Warning: See Cartridge placement instructions on Pages 31 and 50.

- 3) Be sure the Steel Nose is in place.
- 4) Note the location and condition of the QuadGuard® II system and the date of visual drive-by inspection.

Walk-Up Inspection

- 1) Clear and dispose of any debris on the site.
- 2) Be sure all bolts are tight and rust free.
- 3) Be sure concrete anchor bolts are securely anchored.
- 4) Be sure Diaphragm Legs are straight.
- 5) Be sure all Mushroom Washer Assemblies are properly aligned and positioned.
- 6) Fender Panels and Transition Panels should nest tightly against the system.



Warning:	
Fender Panel	Maximum gap allowed:
	Narrow Systems – 20 mm [0.78”]
	Wide Systems – 25 mm [1.00”]

See Figures 74 and 75 on Page 60.

- 7) Be sure Cartridges have not been damaged and are properly positioned on their Support Brackets. Replace crushed or sagging Cartridges. To ensure 100% of the intended speed characteristics, partially crushed Cartridges (due to slow speed impacts) shall be replaced.



Warning: See Cartridge placement instructions on Pages 31 and 50.

- 8) Make all necessary repairs as described above. See Post-Impact Instructions, Page 58, for more information.
- 9) Note the location and condition of the QuadGuard® II system and any work done in the Impact Attenuator Inspection Logbook under the date of this inspection. If further repair is necessary, note repair request date in logbook. See Post-Impact Instructions, Page 58, and assembly section of this Manual for more information.

Post-Impact Instructions

Narrow Systems

- 1) Deploy the appropriate **traffic-control** devices for protection.
- 2) Check to see that all **anchor bolts** have remained firmly anchored in the roadway surface. Replace any that are loose, broken, or pulled out.

If the system is anchored to asphalt, up to 20% of the total anchors may be replaced if damaged. If more than 20% of the anchors are damaged, the system should be relocated to fresh, undisturbed asphalt and redeployed using the 460 mm [18"] threaded rods.

The proper performance of the system during an angle impact depends on the Monorail anchors being properly anchored.

- 3) Clear and dispose of any **debris** on the site.
- 4) Check the system to be certain that the **Mushroom Washer Assemblies** holding the Fender Panels together are still intact and that the system has not been deformed in a way that would prevent pulling it back to its original position.
- 5) Be sure that the **Diaphragm Support Legs** are all properly attached to the Monorail.

Wide Systems

- 1) Deploy the appropriate **traffic-control** devices for protection.
- 2) Check to see that all **anchor bolts** have remained firmly anchored in the roadway surface. Replace any that are loose, broken, or pulled out.

The proper performance of the system during an angle impact depends on the Monorail Anchors being properly anchored.

Note: QuadGuard® II systems for Wide Hazards should never be anchored to asphalt.

- 3) Clear and dispose of any **debris** on the site.
- 4) Check the system to be certain that the **Mushroom Washer Assemblies** holding the Fender Panels together are still intact and that the system has not been deformed in a way that would prevent pulling it back to its original position.
- 5) Be sure that the **Diaphragm Support Legs** are all properly attached to the Monorail.



Caution: Use safety goggles and gloves when refurbishing the Mushroom Spring Assembly. Do not place fingers underneath an assembled Mushroom Washer. Parts may suddenly shift and fingers may be pinched. If the spring is still under compression as the nut is nearing the end of the bolt, to prevent injury, make sure that the spring is restrained with a clamp so it does not suddenly release when nut is removed from the Mushroom Washer Bolt.

- 6) Attach chain to **Pullout Brackets** on first Diaphragm (See Figure 71). Attach both ends of chain to a heavy vehicle (such as a 1 ton pickup.)



Warning: Stand clear in case chain breaks or becomes disconnected.

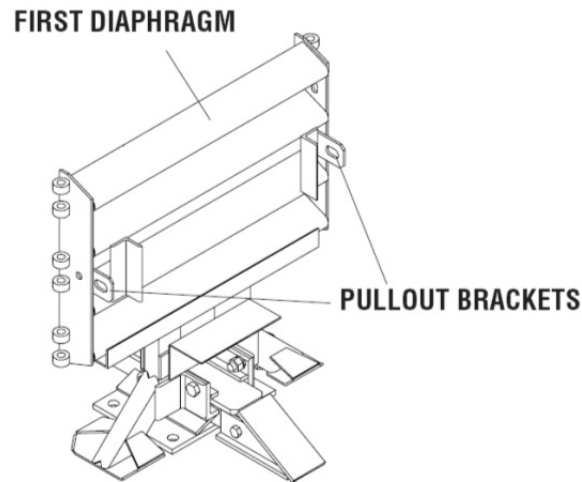

Figure 71
Pullout

Pull the QuadGuard® II system forward slowly until the system reaches its original length. Have someone watch the system during repositioning to be certain previously undetected damage does not cause the Diaphragms to bind or pull out improperly.

- 7) Remove all **crushed Cartridges** from within the system.
- 8) Check to see that the **Diaphragms** are in usable condition. Diaphragms which are bowed or have bent legs must be replaced.
- 9) Check that the **Fender Panels** are properly attached with the **Mushroom Washer Assemblies**. Damaged Fender Panels and Transition Panels must be replaced. Often, **Cartridge Support Brackets** with minor damage can be straight-ended and reused by doing the following:
 - a. Remove damaged Cartridge Support Bracket from Diaphragm.
 - b. Clamp Cartridge Support Bracket to Backup and begin bending using pipe wrench as shown in Figure 72.

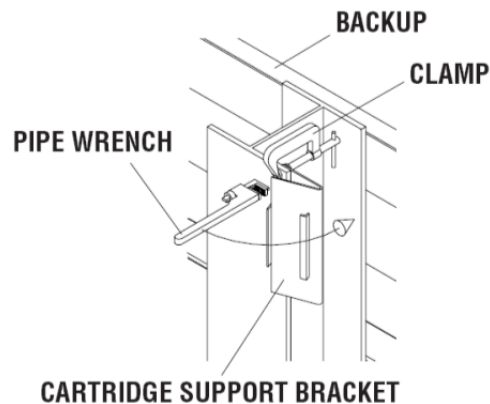

Figure 72
Straighten Cartridge Support Bracket

- c. Then, using a sledge hammer and Quad-Beam™ Panel on Backup as an anvil, straighten Cartridge Support Bracket back into 90° shape (See Figure 73).

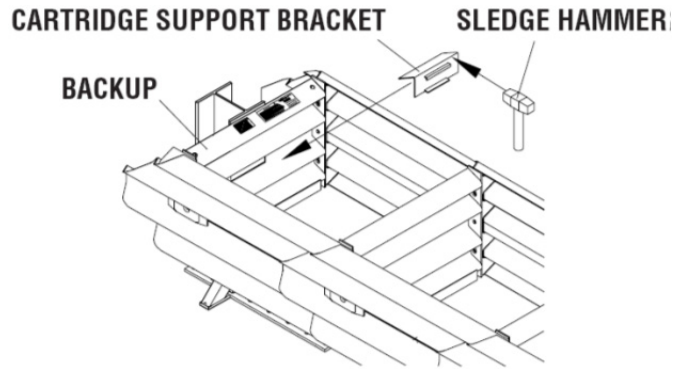

Figure 73
Form Cartridge Support Bracket



Warning:	
Fender Panel	Maximum gap allowed:
	Narrow Systems – 20 mm [0.78”]
	Wide Systems – 25 mm [1.00”]

- 10) Check the **gaps between Fender Panels**. The maximum gap allowed for these overlapping parts (including Fender Panels overlapping Panels behind the system) is 20 mm [.78”] for **narrow systems** and 25 mm [1.00”] for **wide systems**. Be sure the Mushroom Washer Assemblies are torqued to the end of the threads. If the gaps between the Fender Panels are still too large, it may be necessary to replace bent parts.

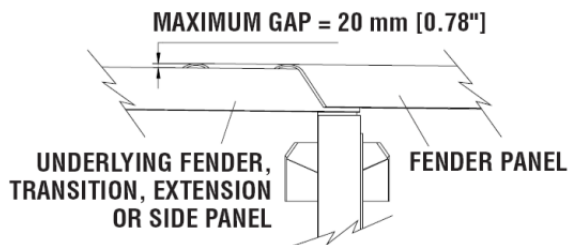

Figure 74
Fender Panel Gap for Narrow Systems

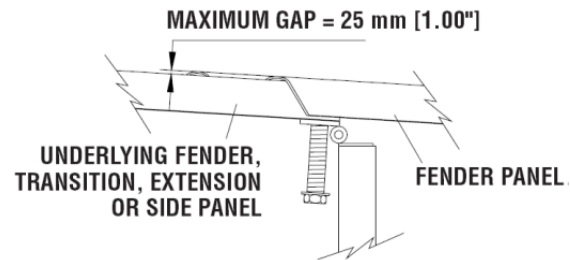

Figure 75
Fender Panel Gap for Wide Systems

- 11) Replace all crushed Cartridges. See **Cartridge Placement** on Pages 31 and 50.
- 12) Remove damaged **Nose Assembly**. Attach the new Nose to the first Diaphragm, using the six threaded rods and four rail nuts per rod. See Pages 28 and 29 for the Nose Assembly.

Table C

Warning:	
Anchor Studs	Torqued to 165 N-m [120 ft-lb] Should NOT Protrude Above Nuts (See Figure 50 on Page 39).
All Other Bolts	Tightened
Fender Panel	Maximum Gap Allowed
Narrow Systems	20 mm [.78"](See Figure 74)
Wide Systems	25 mm [1.00](See Figure 75)

- 13) Check the **torque of all bolts** on the system.
- 14) Check to be certain that the site is free from **any debris**. The QuadGuard® II system is once again ready for use.

Parts Ordering Procedure

Make a list of all damaged parts using part descriptions shown on Pages 63 and 64 of the system images. Answer the following questions in the spaces provided. This information is necessary to receive the proper parts.

Table D
QuadGuard® II System Ordering Information Chart

Description:	Choices	Fill in this section
What is the Width of System? (See "Measuring the Width" Page 12.)	610 mm [24"] 760 mm [30"] 915 mm [36"] 1219 mm [48"] 1755 mm [69"] 2285 mm [90"] 3200 mm [126"]	
What is the Number of Bays? (See "Counting The Number of Bays" Page 11.)	Narrow Hazards: 1 through 9 Wide Hazards: 3 through 9	
What Type of Backup Does the System Have? (See Figure 3 and 4 on Page 12.)	Concrete Tension Strut	
What Type of Transition Panel? (See "Side Panel and Transition Panel Types" Pages 15 and 16.) Be sure to note right side, left side, both sides, (See "How to Determine Left/Right" Page 11) or no Transitions.	<ul style="list-style-type: none"> • Quad to W • Quad to Thrie • Quad to Safety Shape Barrier • Quad to End Shoe • 4" Offset Panel 	

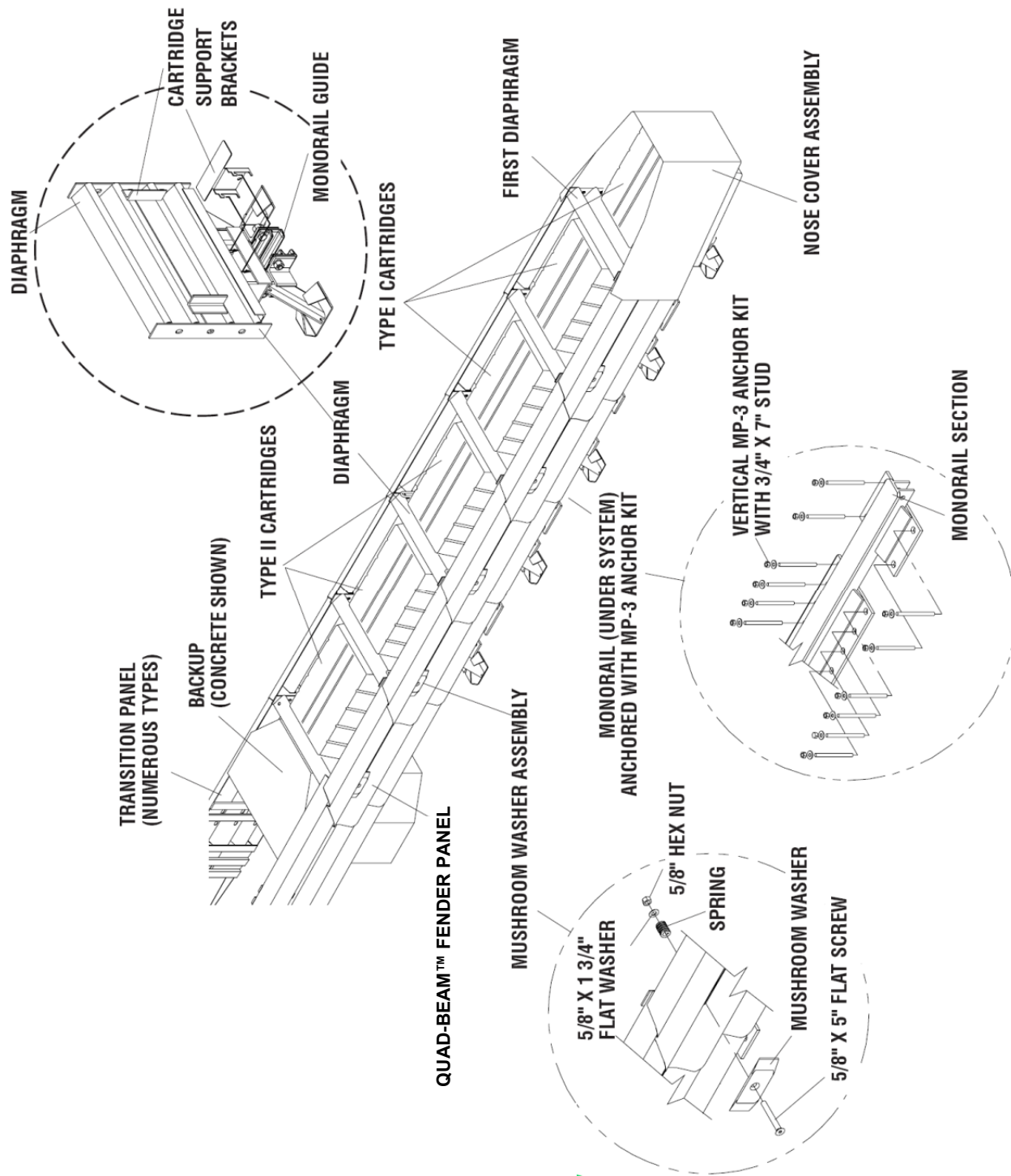

Figure 76
QuadGuard® II for Narrow Hazards

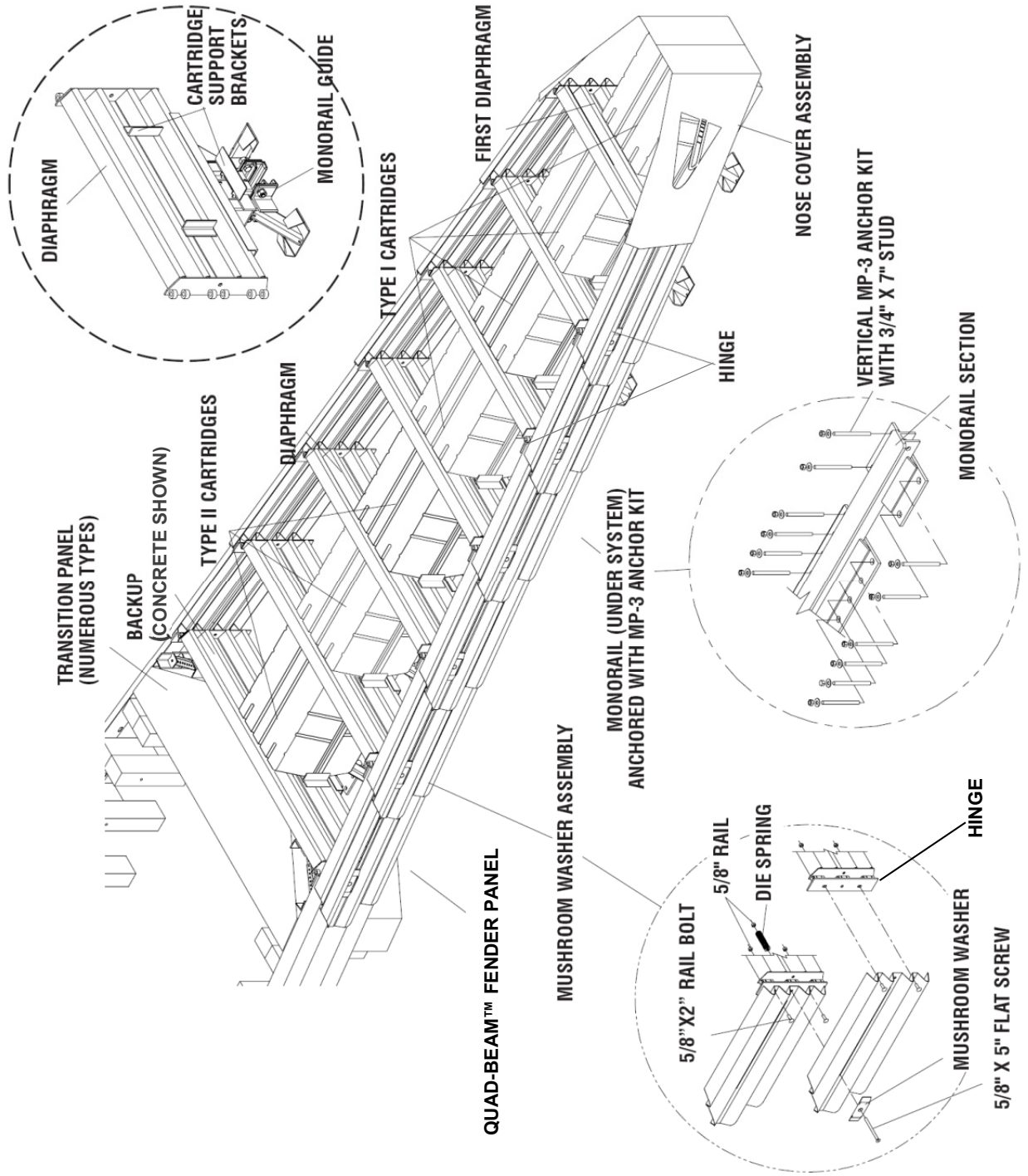

Figure 77
QuadGuard® II for Wide Hazards

Notes:

Notes:



2525 Stemmons Freeway

Dallas, Texas 75207

888-323-6374 (USA only)

214-589-8140 (Outside USA)

www.energyabsorption.com

www.highwayguardrail.com

UNIVERSAL TAU-II®

NCHRP 350 TL-3 Redirective, Non-Gating, Crash Cushion

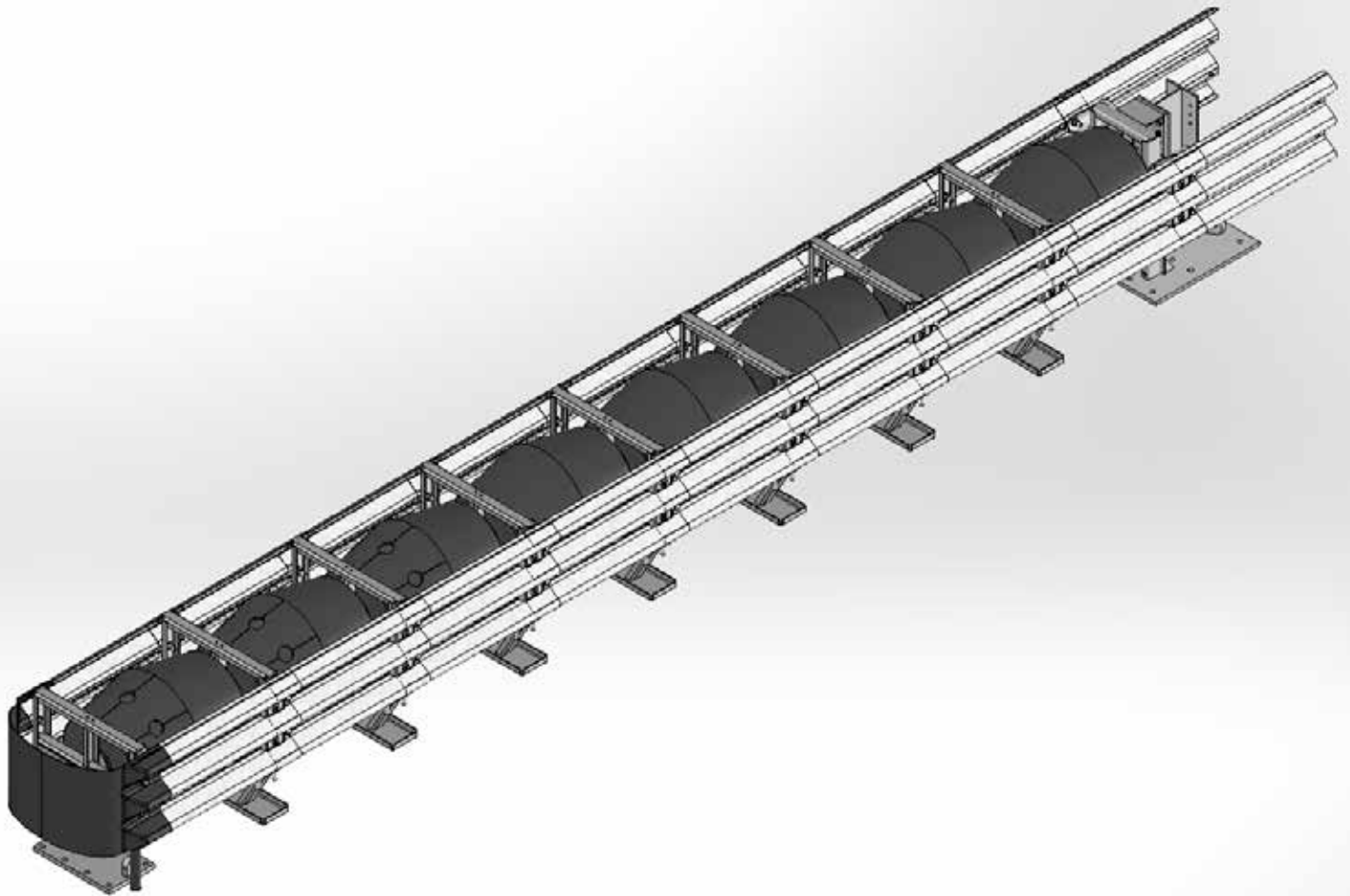

BARRIER SYSTEMS®

BY LINDSAY



STANDARD LIMITED WARRANTY

Lindsay Transportation Solutions, Inc. "LTS" (formerly Barrier Systems) has tested the impact performance of its barriers and crash cushion systems, and other highway safety hardware under controlled conditions, however, LTS does not represent nor warrant that the results of those controlled conditions would necessarily avoid injury to persons or property. LTS EXPRESSLY DISCLAIMS ANY WARRANTY OR LIABILITY FOR CLAIMS ARISING BY REASONS OF DEATH OR PERSONAL INJURY OR DAMAGE TO PROPERTY RESULTING FROM ANY IMPACT, COLLISION OR HARMFUL CONTACT WITH THE PRODUCTS OR NEARBY HAZARDS OR OBJECTS BY ANY VEHICLE, OBJECTS OR PERSONS.

LTS warrants that any product or component part manufactured by LTS will be free from defects in material or workmanship. LTS will replace free of cost any Product or component part manufactured by LTS that contains such a defect.

THE FOREGOING WARRANTY IS IN LIEU OF AND EXCLUDES ALL OTHER WARRANTIES NOT EXPRESSLY SET FORTH HEREIN, WHETHER EXPRESS OR IMPLIED BY OPERATION OF LAW OR OTHERWISE, INCLUDING BUT NOT LIMITED TO ANY IMPLIED WARRANTIES OF MERCHANTABILITY OR FITNESS FOR A PARTICULAR PURPOSE.

LTS' LIABILITY UNDER THIS WARRANTY IS EXPRESSLY LIMITED TO REPLACEMENT FREE OF COST (IN THE FORM AND UNDER THE TERMS ORIGINALLY SHIPPED), OR TO REPAIR OR TO MANUFACTURE BY LTS, PRODUCTS OR PARTS NOT COMPLYING WITH LTS SPECIFICATIONS, OR, AT LTS' ELECTION, TO THE REPAYMENT OF AN AMOUNT EQUAL TO THE PURCHASE PRICE OF SUCH PRODUCTS OR PARTS, WHETHER SUCH CLAIMS ARE FOR BREACH OF WARRANTY OR NEGLIGENCE. LTS SHALL NOT BE LIABLE FOR ANY INCIDENTAL, CONSEQUENTIAL OR SPECIAL LOSSES, DAMAGES OR EXPENSES OF ANY KIND, INCLUDING, WITHOUT LIMITATION, ANY SUCH LOSSES, DAMAGES OR EXPENSES ARISING DIRECTLY OR INDIRECTLY FROM THE SALE, HANDLING OR USE OF THE PRODUCTS FROM ANY OTHER CAUSE RELATING THERETO, OR FROM PERSONAL INJURY OR LOSS OF PROFIT.

Any claim by the Buyer with reference to Products sold hereunder for any cause shall be deemed waived by the Buyer unless LTS is notified in writing, in the case of defects apparent on visual inspection, within ninety (90) days from the delivery date, or, in the case of defects not apparent on visual inspection, within twelve (12) months from the said delivery date. Products claimed to be defective may be returned prepaid to LTS' plant for inspection in accordance with return shipping instructions that LTS shall furnish to the Buyer forthwith upon receipt of the Buyer's notice of claim. If the claim is established, LTS will reimburse that Buyer for all carriage costs incurred hereunder.

The forgoing warranty benefits shall not apply to (i) any Products that have been subject to improper storage, accident, misuse or unauthorized alterations, or that have not been installed, operated and maintained in accordance with approved procedures and (ii) any components manufactured by the Buyer.

TABLE OF CONTENTS

Preface 4
 Introduction 4
 System Overview 4
 Required Tools 4
 Before Installation 5
 Limitations and Warnings..... 5

 Parts Index 6

PARALLEL SYSTEM INSTALLATION

Preparing for installation 8
 Step 1. Backstop Installation 10
 Step 2. Rear Cable Anchor Installation ... 11
 Step 3. Front Cable Anchor Installation ... 12
 Step 4. Install Diaphragms 13
 Step 5. Install Guide Cables 14
 Step 6. Attach Pipe Panel Mounts 15
 Step 7. Install Side Panels 16
 Step 8. Assemble Nose Assembly 18
 Step 9. Install Energy Absorbing
 Cartridges 19
 Step 10. Tension Guide Cables 20
 Step 11. Final Inspection 20

TAPERED SYSTEM INSTALLATION

Introduction 21
 System Overview 22
 Required Tools 22
 Step 1. Foundation Requirements 23
 Step 2. Anchoring System 24
 Step 3. Assemble Bulkheads 25
 The Front Support 26

Middle Assembly 27
 Step 4. Backstop Assemblies 30
 Compact Backstop 31
 Flush Mount Backstop 32
 Wide Flange Backstop 33
 Step 5. Attach Side Panels 35
 Step 6. Attach Nose Piece 36
 Step 7. Install Cables / Guides 37
 Step 8. Stretch and Align System 39
 Step 9. Tension Cables / Torque
 Sliders bolts 39
 Step 10. Install Lateral Support Cables 40
 Step 11. Insert Energy Absorbing
 Cartridges 42
 Step 12. Final Inspection 43

APPENDIX

A. System Configuration Chart 44
B. System Torque Chart 46
C. System Foundation Drawings..... 47
D. System Transition Drawings 63
E. Installation Instructions to BarrierGuard
 800 Steel Barrier 76

PREFACE

The Barrier Systems, Inc. (BSI), Universal TAU-II crash cushion system incorporates the newest roadside safety materials and engineering processes.

As with any roadside safety device, the Universal TAU-II system must be installed properly to insure proper performance. Thoroughly review and fully understand the installation instructions and product limitations before starting the installation. Do not start the installation without the proper plans and tools required for installation.

If you need additional information, or have questions about the Universal TAU-II Crash Cushion, please call the BSI Customer Service Department at (888) 800-3691 (U.S. toll free) or (707) 374-6800.

INTRODUCTION

The TAU-II system has been tested to meet the rigorous requirements of NCHRP Report 350, Test Levels 2 and 3. The systems will be provided in lengths and capacities for both low speed and high speed applications.

The TAU-II system is redirective and non-gating, and is ideally suited for narrow hazards such as the ends of rigid barriers, tollbooths, utility poles and more. Ease of installation, numerous transition options, low maintenance requirements, and reusability of system components make the TAU-II system ideal for treating many roadside hazards.

Redirective, non-gating crash cushions are highway safety devices whose primary function is to improve the safety for occupants of errant vehicles that impact the end of rigid or semi-rigid barriers or fixed roadside hazards by absorbing the kinetic energy of impact or by allowing controlled redirection of the vehicle. These devices are designed to safely decelerate an errant vehicle to a safe stop or redirect an errant vehicle away from roadside or median hazards. These types of systems are typically applied to locations where head-on and angled impacts are likely to occur and it is desirable to have the majority of post impact trajectories on the impact side of the system.

SYSTEM OVERVIEW

The Universal TAU-II system is designed and constructed to provide acceptable structural adequacy, minimal occupant risk and safe vehicle trajectory as set forth in NCHRP 350 for redirective, non-gating crash cushions. Refer to Figure 1 to familiarize yourself with the basic parts and part names of the system.

The Universal TAU-II system is designed to shield the ends of median barriers and other fixed objects likely to be struck head-on, by absorbing and dissipating the kinetic energy of impacting vehicles. Universal TAU-II systems utilize disposable Energy Absorbing Cartridges (EACs) to absorb the kinetic energy of the impacting vehicle. The EACs are separated by diaphragms and held in place with a framework of three-beam corrugated steel rail panels that “telescope” rearward during head-on impacts. As the vehicle compresses the cushion, it exerts a force on the first bay containing an EAC. The diaphragms distribute the impact forces uniformly to all the remaining cartridges in each bay until the vehicle eventually stops. The depth of penetration is dependent upon both the original impact speed and the mass of the impacting vehicle. Only the Energy Absorbing Cartridges are expended after most head-on impacts.

When hit at an angle along the side, the system is restrained laterally by guidance cables that run the length of the system and attach to the bottoms of the diaphragms and terminate at the anchors at each end of the system. The front and rear cable anchors are attached to the foundation as described in Appendix A Foundation Requirements.

BEFORE TAU-II INSTALLATION

Placement and use of the TAU-II system should be accomplished in accordance with the guidelines and recommendations set forth in the “AASHTO Roadside Design Guide,” FHWA memoranda and other state and local standards.

Depending on the application and circumstances at the job site, installation and assembly of a Test Level 3 system should take a two-person crew less than 3 hours.

The TAU-II is a highly engineered safety device made up of a relatively small amount of parts. Before

starting the assembly, become familiar with the basic elements that make up the TAU-II system. The TAU-II system components are illustrated separately in Figure 1 (Pages 6-7).

Limitations and Warnings

The Universal TAU-II system has been rigorously tested and evaluated per the recommendations in the NCHRP Report 350 Guidelines for terminals and crash cushions. The impact conditions recommended in NCHRP 350 are intended to address typical in-service collisions.

When properly installed and maintained, the system is capable of stopping or containing and redirecting impacting vehicles in a predictable and safe manner under the NCHRP 350 impact conditions. Vehicle impacts that vary from the NCHRP 350 impact conditions described for redirective, nongating, crash cushions may result in significantly different results than those experienced in testing.

Vehicle impact characteristics different than or in excess of those encountered in NCHRP 350 testing (speed and angle) may result in system performance that may not meet the NCHRP 350 evaluation criteria.

If you need additional information, or have questions about the Universal TAU-II Crash Cushion, please call the BSI Customer Service Department at (888) 800-3691 (U.S. toll free) or (707) 374-6800.

PROVIDED TOOLS

- Long bolt for nested slider panel installation
- Allen socket for the slider bolt assembly
- Cable socket

REQUIRED TOOLS

- 1/2" [12 mm] drive deep sockets:
 - 7/16 [11 mm]
 - 9/16 [14 mm]
 - 3/4 [19 mm]
 - 13/16 [21 mm]
 - 7/8 [22 mm]
 - 15/16 [24 mm]
 - 1 1/8 [29 mm]
 - 1 1/4 [32 mm]
- 3/4" [19mm] combination end wrench
- 1/2" (12 mm) drive ratchet with extensions
- Rotohammer for drilling holes in concrete:
- 7/8" [22 mm] X 10" [250 mm] bit for chemical anchors
- 1/2" Torque wrenchs:
- 20 ft-lbs [27 N-m] and 500 ft-lbs [680 N-m] capacity
- Measuring tape
- Safety Equipment: Glasses, Gloves
- 1/2" (12 mm) Air impact wrench (Optional)

Note: The tools list is a general recommendation. Depending on the specific characteristics of the job site, more or less tools may be necessary.

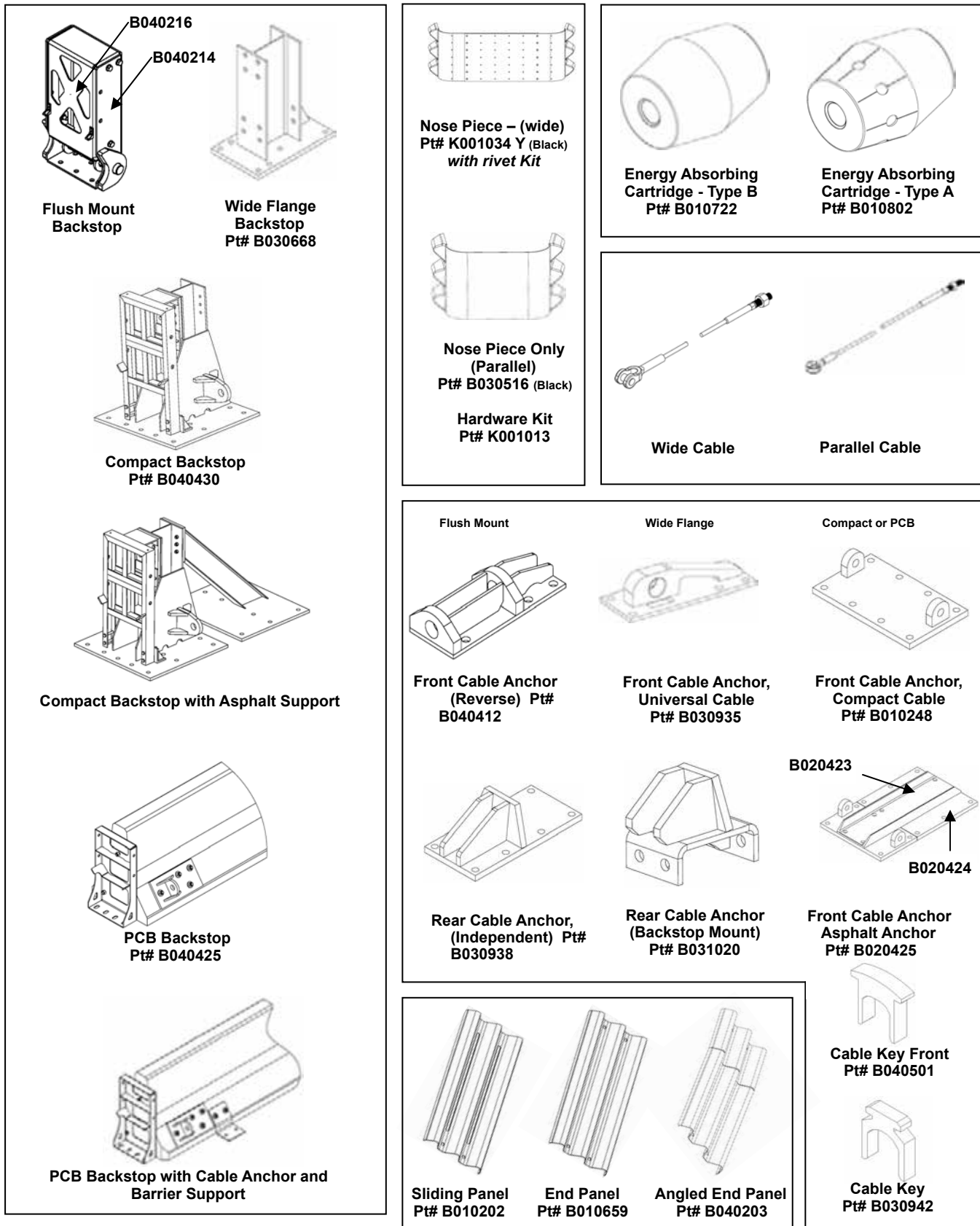
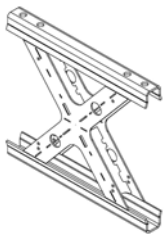
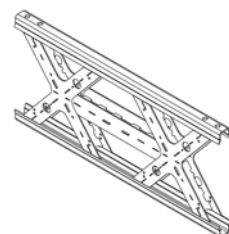
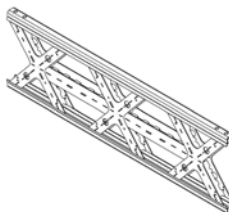
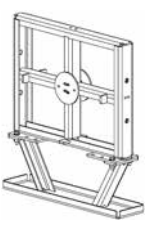
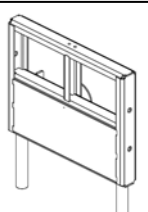
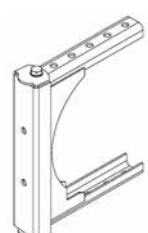
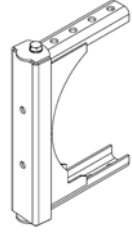
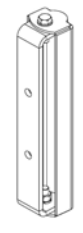
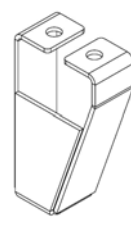
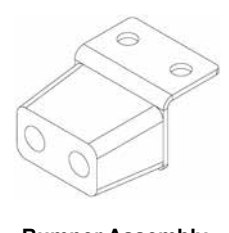
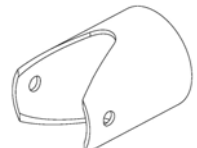
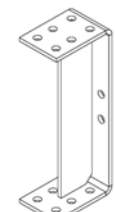

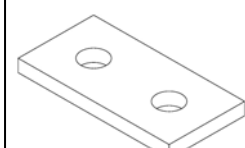
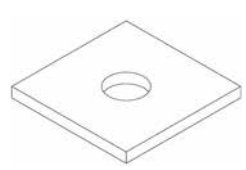
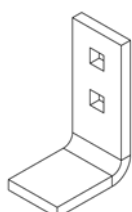
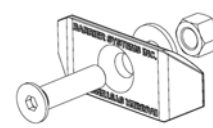
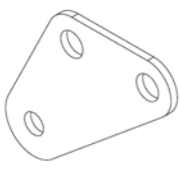
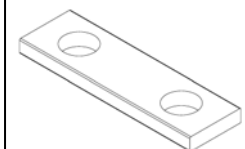

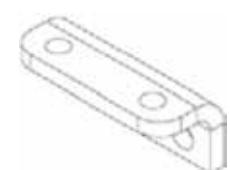

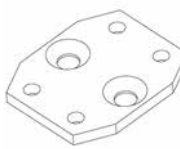

Figure 1. Illustrated parts list

				
XL Bulkhead Pt# B030521	XXL Bulkhead Pt# B030528	XXXL Bulkhead Pt# B030529	Middle Support Pt# B030703	Front Support Pt# B030704
Leg Kit Pt# K001005				

				
Wing Assembly Pt# B030509	Transition Wing Assy. Pt# B030910	36 Inch Adapter Assy Pt# B031201	Leg (wide) Pt# B030425	Bumper Assembly (wide) Pt# B031035

				
Pipe Panel Mount Pt# B010651	Backstop Blockout (wide) Pt# B030713	Front Collision Plate (wide) Pt# B030801	Wing Brace (wide) Pt# B030821	Spacer - Wing Brace (wide) Pt# B030823
Hardware Kit Pt# K001017				

				
Level Spacer Pt# B030551	EAC Locator Kit (X4) Pt# K001028	Slider Assembly Kit (x4) Pt# K001003	Leg Adapter (wide) Pt# A040223	Backing Plate (wide) Pt# B030543

				
Lateral support Mount, (Backstop Mount - wide) Pt# B031011	Lateral Support Cable Assembly Kit Pt# K001031	Bulkhead Mount, Lateral Support - (wide) Pt# B031010	Cable Guide Mounting Plate - (wide) Pt# B030411	Cable Guide Assembly Kit (x4) Pt# K001004

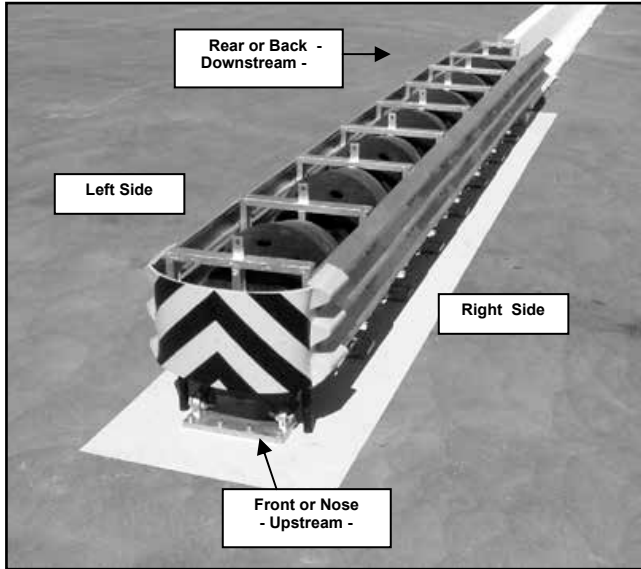

Sign Conventions

The picture of the TAU-II system above is labeled to show the descriptive terms that will be used throughout this manual.

Preparing for installation

Depending on the size of the system ordered, the parts will be shipped on two to five pallets. Assembly of the TAU-II system is typically done at the worksite. (If preferred, the system can be assembled “off-site” and set into position as one piece, with a forklift or crane.)

Before beginning the assembly of the TAU-II system, check the packing list to be certain that all of the system components were included in the shipment.

The TAU-II Crash Cushion system has been designed to attach to concrete or asphalt foundations. BSI recommends that at a minimum, the system be anchored to standard six-inch reinforced 4,000 psi (28 MPa) Portland Cement Concrete (PCC) pad or roadway, or 8” (200 mm) AR-4000 Asphalt Concrete. When installing to concrete, care must be taken when building the concrete pad to space the rebar so as to minimize interference with the anchor bolt holes.

(See Appendix “C”, Page 47, for BSI recommended foundation options and material specifications.)

NOTE:

It is important to determine the system’s installation position and angle, to optimize proper function and transition.

This system is available in two configurations:

- 1) The system can be attached directly to the end of a concrete barrier, utilizing the “PCB Backstop” (BSI part # B040425) or the “Flush Mount Backstop” (BSI part # B040219).
- 2) The second configuration utilizes a “Compact Backstop” (BSI part # B010537) which is a free standing back support.

This manual describes the installation procedure for an 8 bay (Test Level 3) system.

(See the System Configuration Chart in Appendix “A”, Page 44, for guidelines on choosing a system length to accommodate different traffic criteria.)

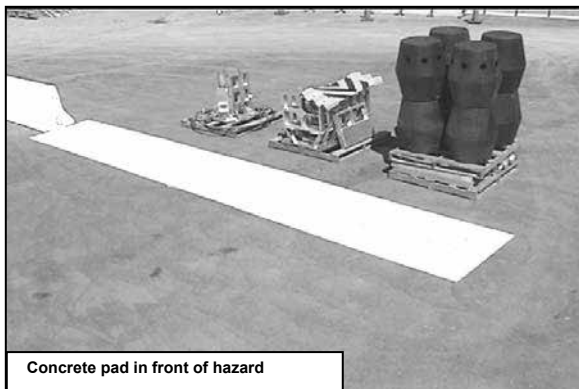

Concrete pad in front of hazard

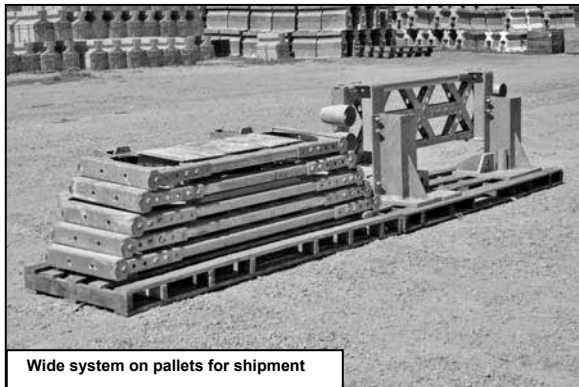

Wide system on pallets for shipment

Depending on the installation design, transition hardware may be necessary. Because each transition is unique, BSI recommends that the transition hardware be properly fitted before anchoring the system. Pre-assemble the transition

hardware before setting the system base plates to assure the proper spacing between the system and the object being treated.

(NOTE: See Appendix "D", Page 63, for some recommended transition types)

CONCRETE PAD INSTALLATION

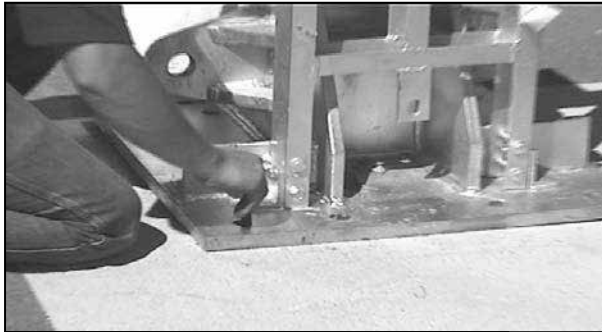

Use the Base Plate of the Compact Backstop as a template

Step 1. (Compact Backstop to Concrete Foundation)

Place the Compact Backstop in the desired final installation position. Use the holes in the base plate as a template to mark the location of the anchor points. Remove the backstop and drill the anchor bolt holes. The holes should be 6" (150 mm) deep and 7/8" (22 mm) diameter. Install the anchors into the pad following the instructions included with the anchor epoxy. When the epoxy is fully cured, install the nuts and flat washers. Tighten to 120 ft-lbs (160 N-m).



Use the P.C.B. Backstop as a template to drill the holes

Step 1. (PCB Backstop to Concrete Foundation)

Place the PCB Backstop in the desired final installation position. Use the holes in the backstop as a template to mark the location of the anchor points. The holes should be 6" (150 mm) deep and 7/8" (22 mm) diameter. Use a caulking gun and gun insert filled with anchoring compound to secure the 3/4" x 8 1/4" (20 mm x 610 mm) galvanized anchors. Torque to 120 ft-lbs (160 N-m).

ASPHALT INSTALLATION



Compact Backstop Base with Asphalt Adapter

Step 1. (Compact Backstop to Asphalt)

If the unit is being installed on asphalt, the Asphalt Adapter must be attached to the Compact Backstop. Use the base as a template to mark the anchor point locations. All holes should be 15 to 16 1/2" (380 to 420 mm) deep. Use 18" (460 mm) anchors for the Compact Backstop and the Asphalt Adapter. Install the anchors into the foundation following the instructions included with the anchor epoxy. When the epoxy is fully cured, install the nuts and flat washers. Tighten to 120 ft-lbs (160 N-m).

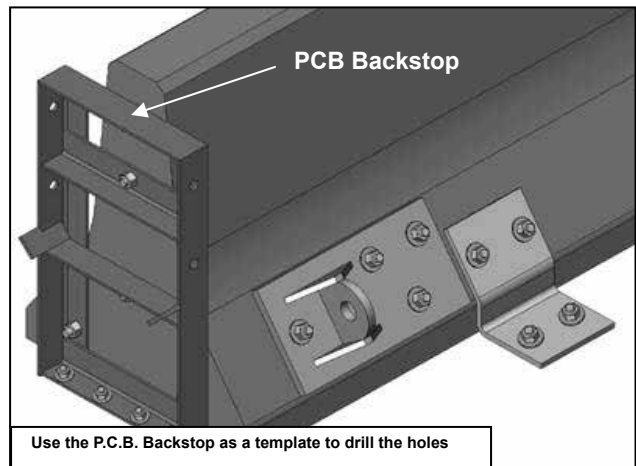

Use the P.C.B. Backstop as a template to drill the holes

Step 1. (PCB Backstop to Asphalt Foundation)

Place the PCB Backstop in the desired final installation position. Use the holes in the backstop as a template to mark the location of the anchor points. The holes should be 6" (150 mm) deep and 7/8" (22 mm) diameter. Use a caulking gun and gun insert filled with anchoring compound to secure the 3/4" x 8 1/4" (20 mm x 610 mm) galvanized anchors. Torque to 5 ft-lbs (8 N-m).

CONCRETE PAD INSTALLATION

Step 2. (Concrete Rear Cable Anchors)

NOTE: IF YOU ARE USING THE COMPACT BACKSTOP, SKIP TO STEP 3.

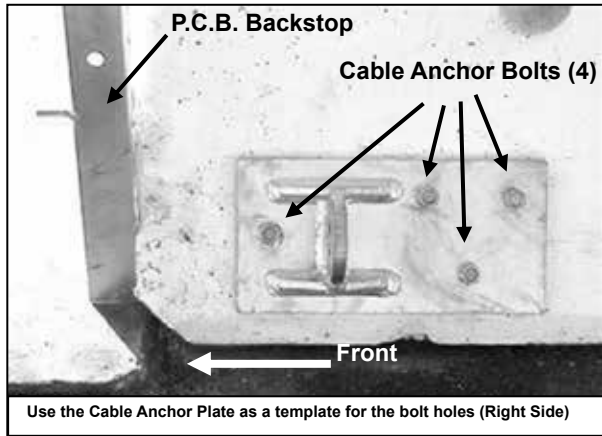

Use the holes in the plate as a template to mark the location of the holes for the anchor studs. (There is one Cable Anchor for each side of the P.C.B.). The holes should be drilled 6" (150 mm) deep and 7/8" (22 mm) in diameter. Install the (all thread) studs into the PCB following the instructions included with the anchor epoxy. When the epoxy is fully cured, install the nuts and flat washers. Tighten to 120 ft-lbs (160 N-m).

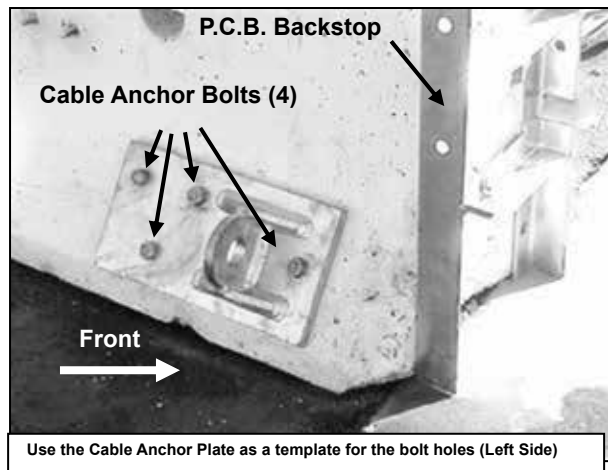

NOTE: For proper system performance, the concrete barrier must be rigidly attached to an adequate foundation. See Appendix "C" for Anchor Foundation Options and Page 24 for anchoring material options..

ASPHALT INSTALLATION

Step 2. (Asphalt Rear Cable Anchors)

NOTE: IF YOU ARE USING THE COMPACT BACKSTOP, SKIP TO STEP 3.

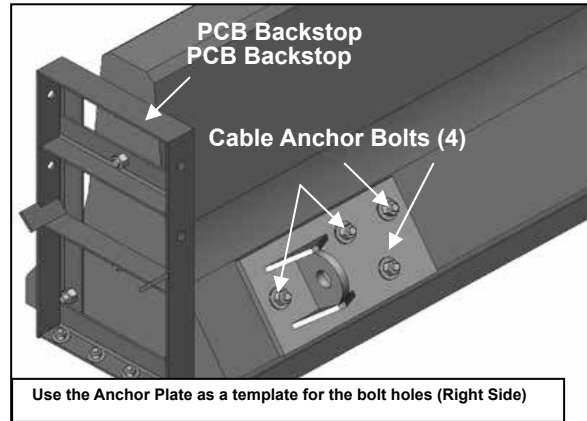

Refer to the Installation Drawings in Appendix "C" to determine the correct Cable Anchor installation position. Use the holes in the plate as a template to mark the location of the holes for the anchor studs. (There is one Cable Anchor for each side of the P.C.B.). The holes should be drilled 6" (150 mm) deep and 7/8" (22 mm) in diameter. Install the (all thread) studs into the PCB following the instructions included with the anchor epoxy. When the epoxy is fully cured, install the nuts and flat washers. Tighten to 120 ft-lbs (160 N-m)

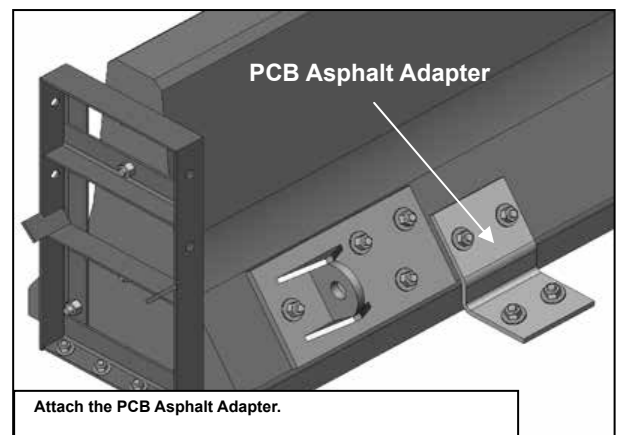

Attach the PCB Asphalt Adapter. Drill holes 6" (150 mm) deep and 7/8" (22 mm) in diameter in the concrete barrier. Drill 15 to 16 1/2" (380 to 420 mm) in the foundation and install 18" (460 mm) anchors following the instructions included with the anchor epoxy. When the epoxy is fully cured, install the nuts and flat washers. Tighten to 120 ft-lbs (160 N-m).

CONCRETE PAD INSTALLATION

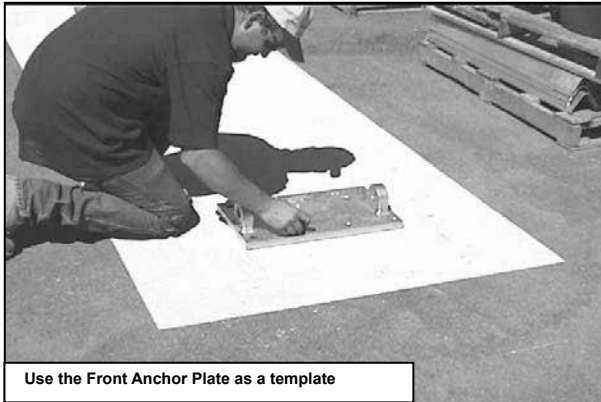

Use the Front Anchor Plate as a template

Step 3. (Concrete Front Cable Anchor)

Place the Front Cable Anchor in the desired final installation position. Use **Appendix C** for layout dimensions. Use the holes in the plate as a template to mark the location of the anchor points. Remove the plate and drill the anchor bolt holes to the desired size and depth. The holes should be 6" (150 mm) deep and 7/8" (22 mm) diameter.

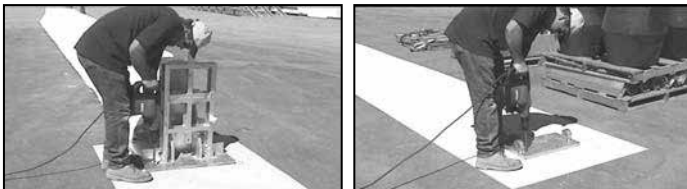

Drill the anchor bolt holes to the proper size and depth

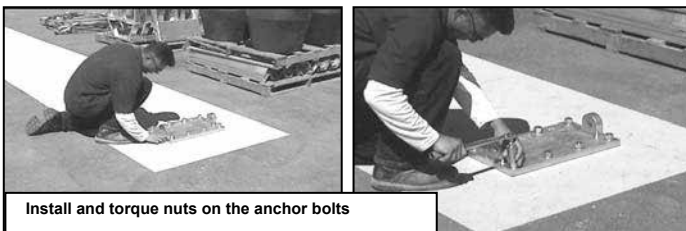

Install and torque nuts on the anchor bolts

NOTE:

It is important that the holes are drilled straight and in the correct position so that the plate will fit back over the bolts after they have been set with anchoring material. If the total hole depth cannot be reached due to rebar interference, a "diamond tip" drill or equivalent should be used to reach the total hole depth.

ASPHALT INSTALLATION

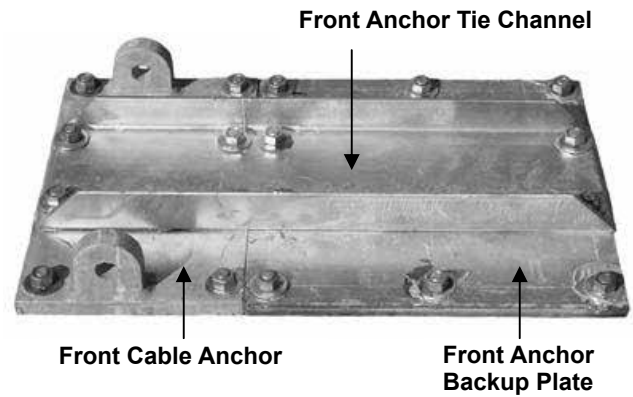

Step 3. (Asphalt Front Cable Anchor)

The Asphalt Front Cable Anchor is a three piece unit. Place the Front Cable Anchor and the Front Anchor Backup Plate in the desired final installation position. Use the holes in the plates as a template to mark the location of the anchor points. Remove the plates and drill the anchor bolt holes to the desired size and depth. The holes should be 15 to 16 1/2" (380 to 420 mm) deep and 7/8" (22 mm) diameter. **Install the cable and clevis pin before installing the Front Anchor Tie Channel.** Install the Front Anchor Tie Channel on top of the Front Cable Anchor and the Front Anchor Backup Plate.

NOTE:

It is important that the holes are drilled straight and in the correct position so that the plate will fit back over the bolts after they have been set with anchoring material. If the total hole depth cannot be reached due to interference, a "diamond tip" drill or equivalent should be used to reach the total hole depth.

ALL FOUNDATIONS

After the anchoring epoxy is properly cured, install a nut and washer on each of the anchor bolts extending through the base plates of the Backstop and Front Cable Anchor plate.

For PC Concrete foundations, torque the nuts to 120 ft-lbs (160 N-m).

For Asphaltic Concrete foundations, torque the nuts to 5 ft-lbs (8 N-m).

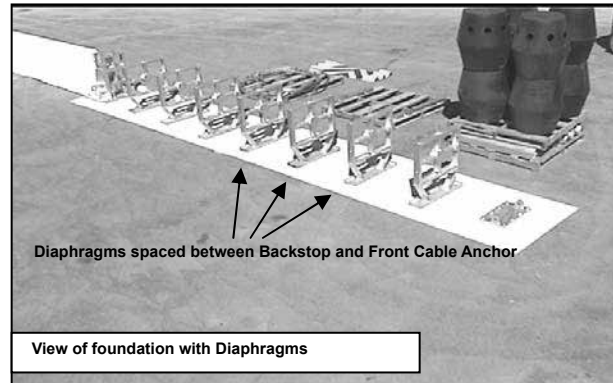

Diaphragms spaced between Backstop and Front Cable Anchor

View of foundation with Diaphragms

The photo above shows what the installation would look like after the diaphragms have been placed between the Backstop and the Front Cable Anchor.

NOTE: Do not install the Front Support Assembly and nose piece at this time, it will be installed later.

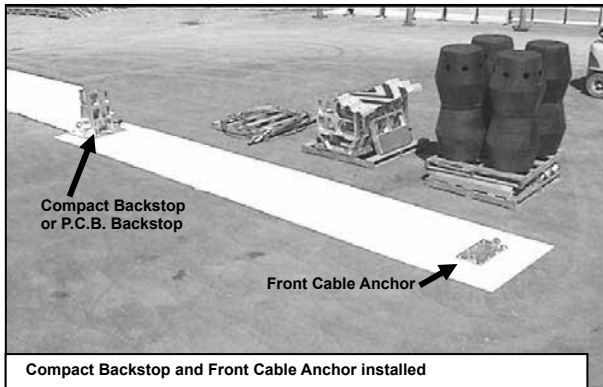

Compact Backstop or P.C.B. Backstop

Front Cable Anchor

Compact Backstop and Front Cable Anchor installed

This photo shows a view of how the installation would look after the Backstop and Front Cable Anchor are securely fastened.

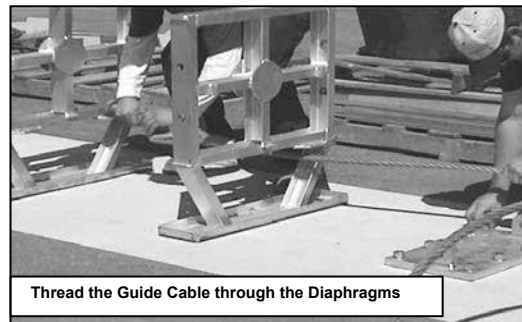

Thread the Guide Cable through the Diaphragms

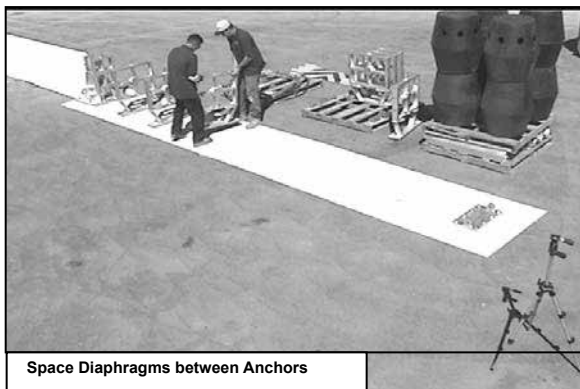

Space Diaphragms between Anchors

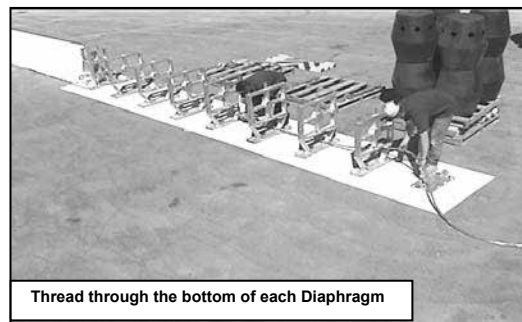

Thread through the bottom of each Diaphragm

Step 4.

The Diaphragms should be spaced (one by one) evenly between the Front Cable Anchor and the Backstop. It is not important that they be exactly spaced at this point as they can easily be moved into the desired final assembly position when necessary.

Step 5.

Starting at the upstream end of the system, thread the Guide Cable through the space in the bottom of the Diaphragms. Make sure to pull the threaded cable end through first so that it will end up at the back of the unit. (Make sure that the Guide Cable is threaded through the bottom of each Diaphragm.)

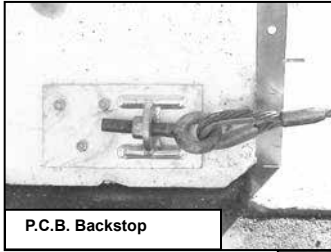

P.C.B. Backstop



Compact Backstop

Push the threaded end of the cable through the hole in the anchor tab on the left side of the Compact Backstop. Install the nut on the end of the adjusting screw.

NOTE: Do not thread the nut beyond the end of the adjusting screw at this time. The nut will be tightened later.

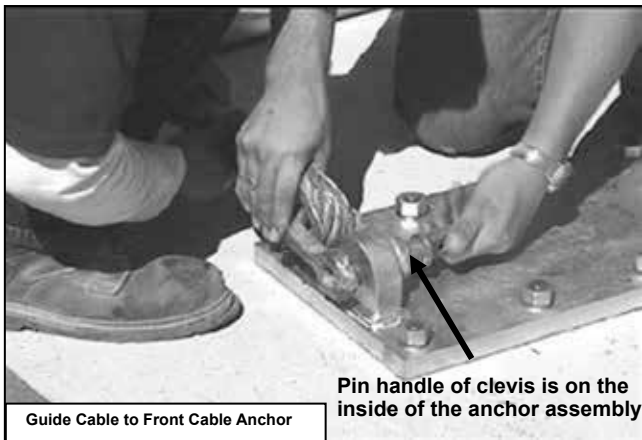

Guide Cable to Front Cable Anchor

Pin handle of clevis is on the inside of the anchor assembly

Attach the other end of the Guide Cable to the left side of the Front Cable Anchor by first removing the pin from the clevis (shackle). Place the clevis over the anchor eye and re-install the pin through the eye, making sure that the handle portion of the pin is on the inside of the anchor assembly. Firmly tighten the pin.

For asphalt installations, the cable and clevis pin have been attached in Step 3 (Page 12). Repeat the process outlined in steps 6, 7, and 8, for the

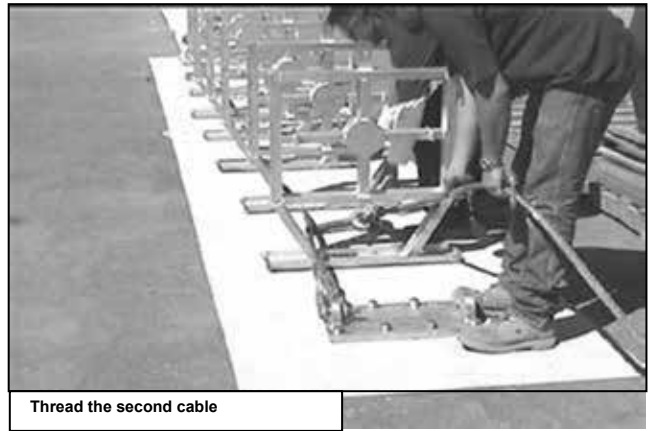

Thread the second cable

other cable. Install the second cable along the right side of the system without crossing the first cable.



Attach cables to bottom of Diaphragms

Use the Cable Guide Assembly blocks to attach the Guide Cable to the bottom cross rail of the Diaphragms. The cable blocks consist of two grooved halves that, when put together, provide a path for the Guide Cable to move through.

It is easiest to install the Cable Guides by first placing the two halves of the blocks together around the cable. Next, hold the blocks and cable up to the plate on the bottom of the Diaphragm. Push the bolt from the top down through the plate and then through the blocks.

NOTE: See Page 28, Figure 9 for cable guide positions for wide flange systems.

Install a lock washer and nut to secure the bolt. Continue the process until all four of the attachment bolts are installed on each Cable Guide Assembly.

NOTE: If properly installed, the Guide Cable should slide freely through the Cable Guide blocks and the Diaphragm should slide freely along the cable.

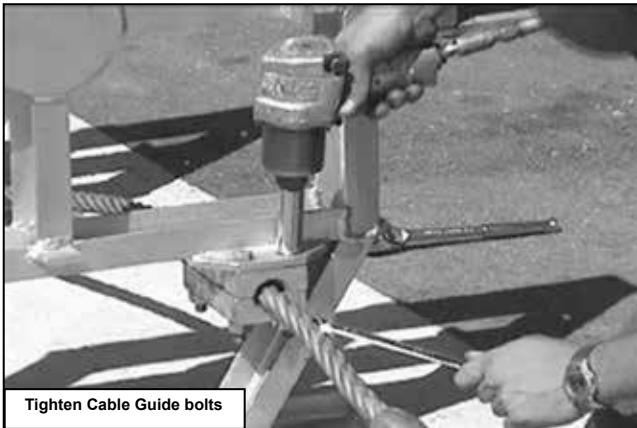

Tighten Cable Guide bolts

Use an impact wrench (or hand tools) to securely tighten the (4) bolts holding the Cable Guide blocks to the plate on the bottom of each Diaphragm. Use the Cable Guide Hardware Kit #K001004.

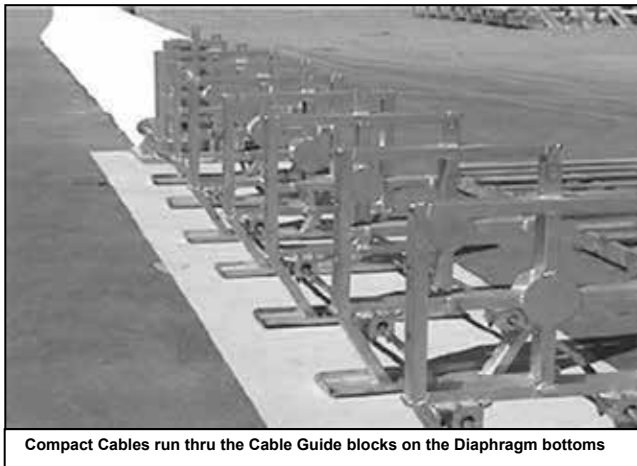

Compact Cables run thru the Cable Guide blocks on the Diaphragm bottoms

The photo above shows what the Diaphragms should look like after the Cable Guide blocks have been installed.

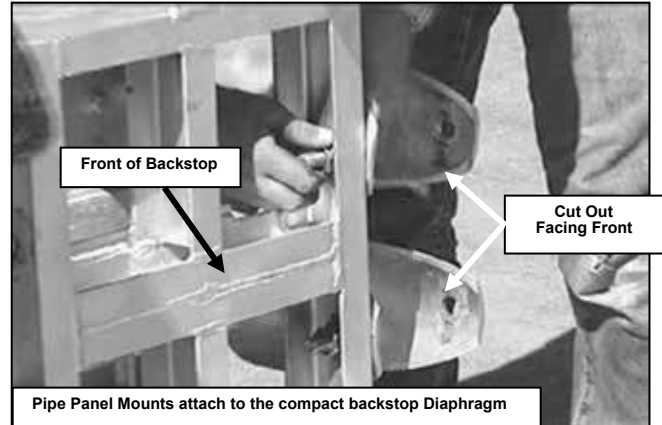

Pipe Panel Mounts attach to the compact backstop Diaphragm

Step 6.

Attach the Pipe Panel Mounts to the sides of the Backstop. (The End Panels are not attached directly to the Backstop Diaphragm.) The Pipe Panel Mount attaches between the Backstop Diaphragm and the End Panel to facilitate proper system performance during side impacts in this area.

The Pipe Panel Mount is made from a piece of 6" (150 mm) diameter galvanized pipe with angles of material cut out of the top and bottom of one end.

NOTE: It is important that the end of the mount that is cut flat be facing the back (downstream) end of the system and that the cut out end of the Pipe Panel Mount be facing toward the front (upstream).

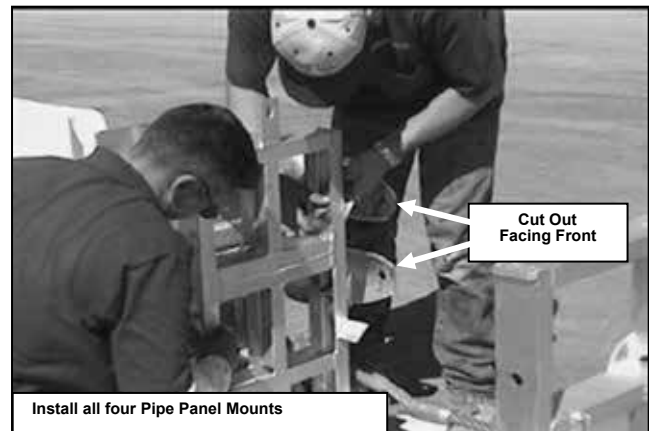

Install all four Pipe Panel Mounts

To attach the Pipe Panel Mount to the Backstop Diaphragm, place a washer on the attachment bolt and push the bolt through the inside hole on the Pipe Panel Mount and continue the bolt through the hole located on the side of the Diaphragm that is a part of the Backstop as shown in the photo above. Use the Pipe Panel Hardware Kit #K001017.

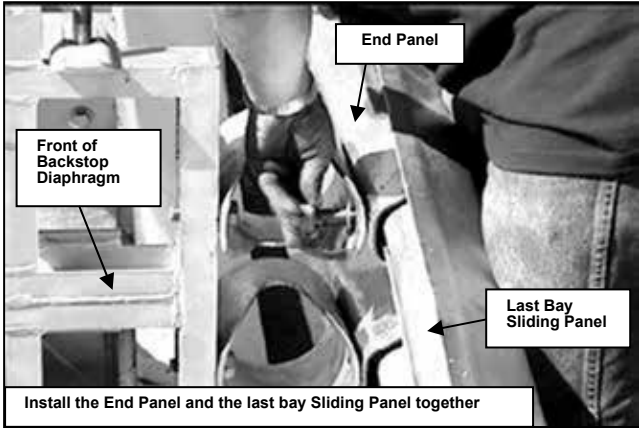

Step 7.

At this point you will start assembling the sides of the system. The first two side panels are installed together as the Sliding Bolt attaches both of the panels to the Pipe Panel Mount located on the side of the Backstop Diaphragm. Attach the right side End Panel and right side rear-most Sliding Panel to the Pipe Panel Mount using the Sliding Bolt.

Insert the Slider Bolt through the slotted portion of the last bay Sliding Panel. Continue the bolt through the front hole of the End Panel. Continue the bolt through the bolt hole in the outside of the Pipe Panel Mount as shown in the photo above.

NOTE: For the system to telescope properly, the slotted Sliding Panel MUST be on the outside of the End Panel.

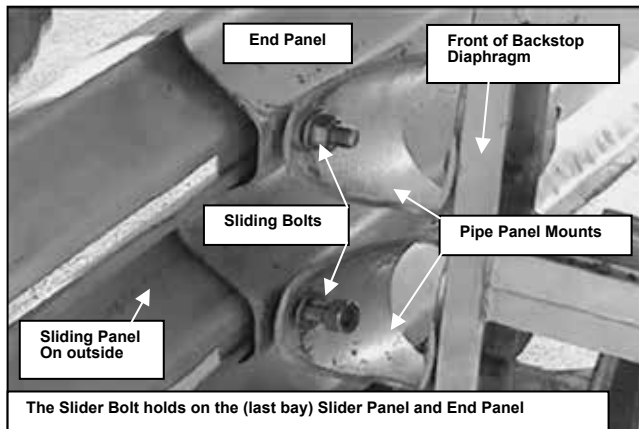

The photo above shows the end of the Slider Bolt coming through (from the outside) the slot in the last left bay side Sliding Panel, through the front hole of the End Panel and through the outer hole of the Pipe Panel Mount.

NOTE: See configuration chart to determine if you have “stacked” or “nested” slider panels in some locations.

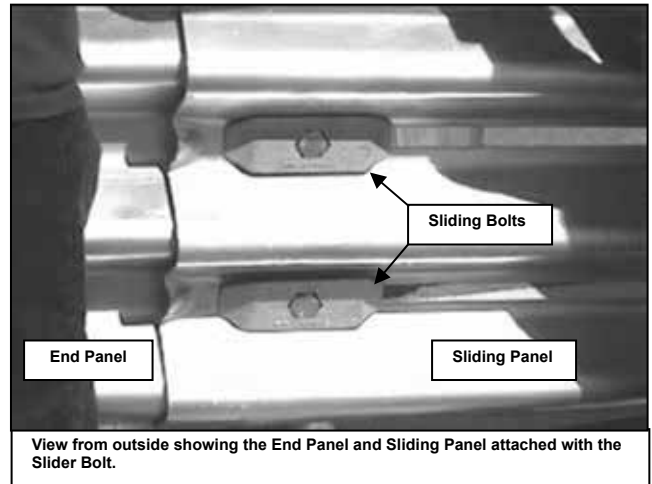

NOTE: For ease in assembly of the rest of the system, hand tighten the nut on the Slider Bolts. The bolts will be tightened in a later step. Use Slider Bolt Hardware Kit #K001003.



You will now attach the right side panels one-by-one, moving towards the front of the system. Attach the rear bay and second-to-last bay Sliding Panels to the first diaphragm using Sliding Bolts. Insert the Sliding Bolt through the slot in the second-to-last bay Sliding Panel. Continue pushing the bolt through the hole in the front of the last Sliding Panel and finally push the bolt through the hole in the side of the corresponding Diaphragm.

NOTE: For the system to telescope properly, the forward most slotted Sliding Panel MUST be on the outside.

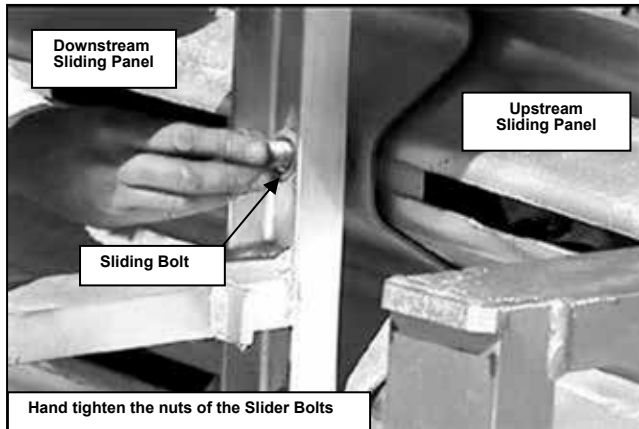

Repeat this step until all Sliding Panels have been mounted to the Diaphragms. The forward-most Sliding Panel must always be on the outside of the system (next to the mushroom head of the sliding bolt).

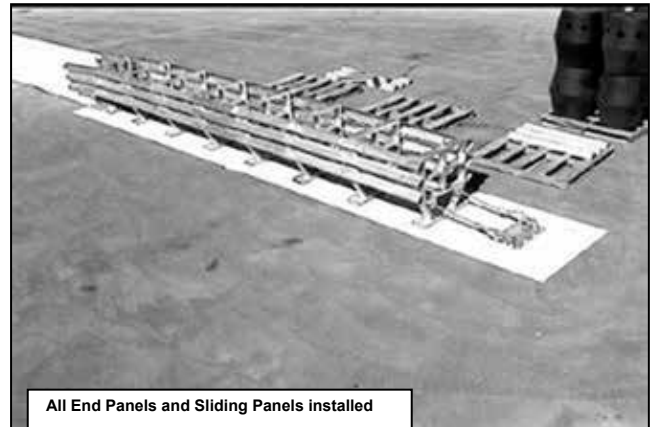

The photo above shows what the system will look like after both of the End Panels and all of the Sliding Panels have been installed.

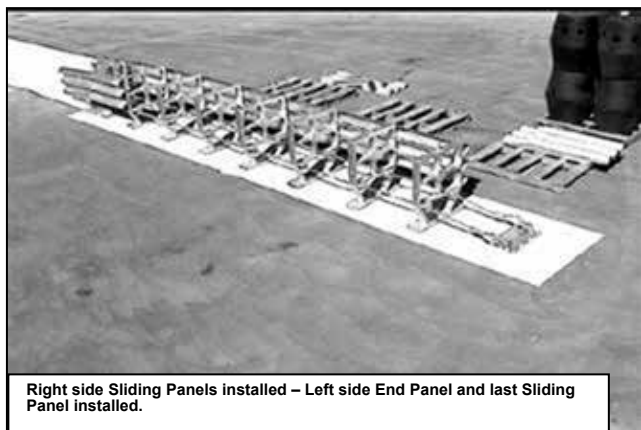

The photo above shows what the system will look like after the End Panel and all of the Sliding Panels have been installed on the right side as well as the End Panel and rear-most Sliding Panel on the left side.

Continue attaching the Sliding Panels along the left side of the system until all of the Sliding Panels are installed.

NOTE: For the system to telescope properly, the forward most slotted Sliding Panel MUST be on the outside.

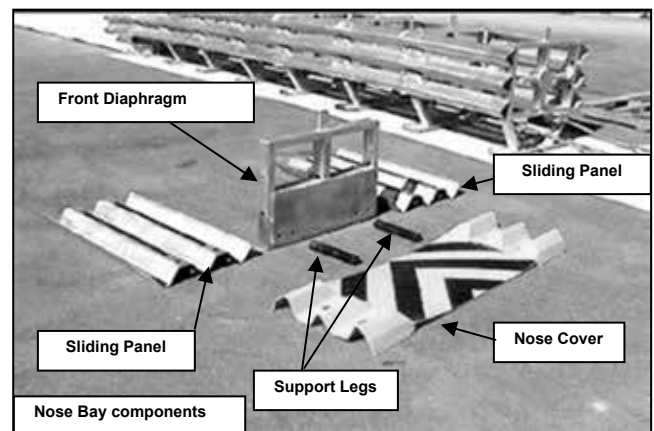

The final bay will be assembled separately from the rest of the system and then installed as a complete unit. The components that make up the final bay are two Sliding Panels, the Front Diaphragm, the Nose Cover and the Leg Supports.

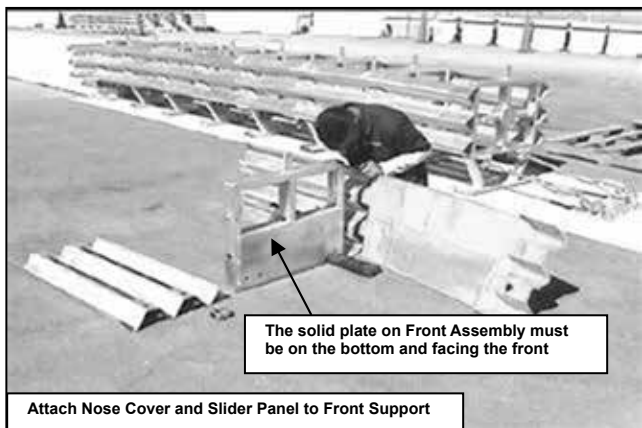

Step 8.

Attach the Nose Cover and left Slider Panel to the Front Support. Install the bushing in the hole of the nose piece. Install the fender washer on the machine bolt (Slider Bolt not used) and push the bolt through the bushing in the Nose Cover hole. Continue the bolt through the hole in the front edge of the last-bay Slider Panel and finally push the bolt through the hole in the Front Diaphragm. Install the washer and hand tighten the nut. (The nut will be tightened later.) Use Nose Piece Hardware Kit #K001013.

The final step in the assembly of the nose bay is to install the Support Legs. Place the nose assembly on its side. Push one of the leg support machine bolts and washer through the hole in the bottom rail of the Front Support. Screw the Leg Support onto the bolt and tighten the bolt with a wrench or socket.

Warning: DO NOT OVER-TIGHTEN THIS BOLT. Use the Front Support Leg Hardware Kit #K001005.



Repeat the process outlined in Step 8 with the right side of the assembly.

Carry the complete nose bay assembly to the front of the system. Attach the Slider Panels to the diaphragm by pushing the Slider Bolt through the slots in the final bay Slider Panels and then through the hole in the front of next bay Slider Panel. Finally, push the Slider Bolt through the hole in the side of the Diaphragm and attach the flat washer and nut.

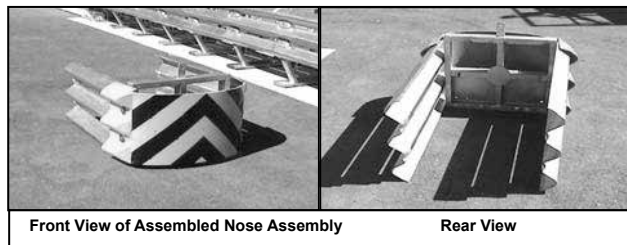

NOTE: For the system to telescope properly, the forward most slotted Sliding Panel MUST be on the outside.

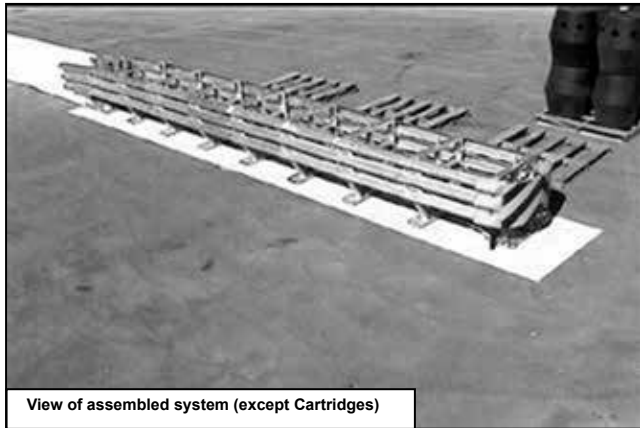

View of assembled system (except Cartridges)

It is important to make sure that the system bays are fully extended to ensure that the Energy Absorbing Cartridges will fit properly. Pull the Slider Panels of each bay until fully extended, working from the base toward the nose assembly.

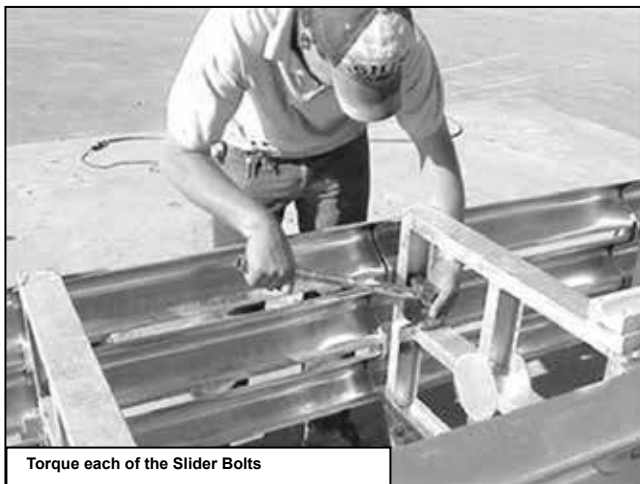

Torque each of the Slider Bolts

Torque all of the Sliding Bolts to 20 ft-lbs (27 N-m). Torque the Front Panel Bolts (holding nose cover) to 200 ft-lbs (270 N-m). Do not overtighten.

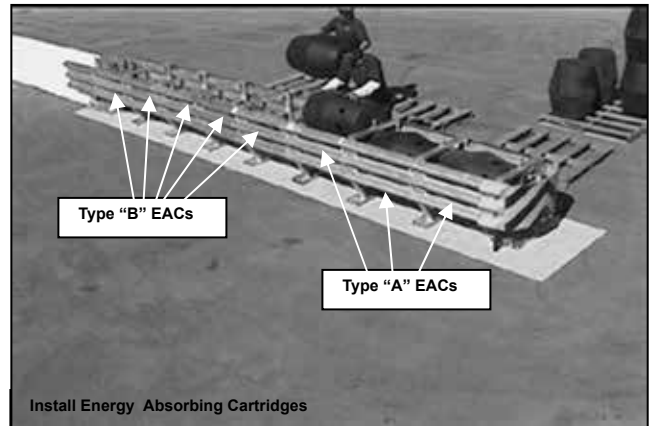

Step 9.

Insert a Type “A” Energy Absorbing Cartridge into each of the first three (3) bays of the 8 bay (TL-3) system. The Type “A” cartridges have holes and slots on the sides toward the end of the cartridge. Install each cartridge on its side with the holes and slots facing the front (upstream) of the system.

Insert a Type “B” Energy Absorbing Cartridge into the remaining five (5) bays. The Type “B” Cartridges have three holes on one end of the cartridge. Install each cartridge on its side with the holes facing the back (downstream) of the system.

Refer to the matrix in Appendix “A” for proper cartridge configurations.

NOTE: For proper system performance, the Energy Absorbing Cartridges must be installed in the proper order and in the proper direction as shown in Appendix “A”.

ASPHALT INSTALLATION

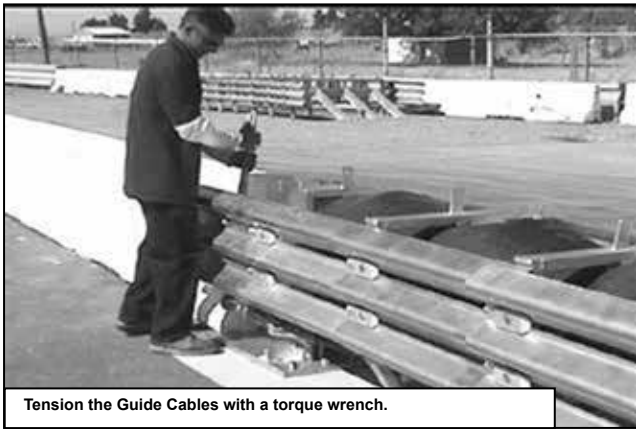

Tension the Guide Cables with a torque wrench.

Step 10.

The final step in the installation of the TAU-II system is to apply tension to the Guide Cables that run underneath the system.

CONCRETE INSTALLATION:

Torque the nut on the end of the threaded cable end to 500 ft-lbs (680 N-m).

Torque the nut on the end of the adjustable Eye Bolt to 120 ft-lbs (160 N-m).

NOTE: For proper performance, the cables must be tensioned properly.

Step 11.

Use the check list on page 43 to confirm that all of the installation steps have been completed.

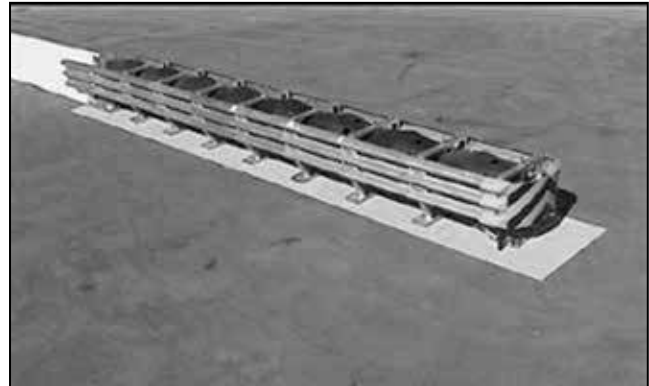

Complete Test Level 3 system (8 bay)

The above photo shows what a completely installed Test Level 3 TAU-II system with a compact backstop will look like.

INTRODUCTION

This manual is organized in steps that address each of the different installation options that are available. The Universal TAU-II system is very versatile and also easy to assemble and install if these basic guidelines are followed.

The Universal TAU-II system has been tested to meet the rigorous requirements of NCHRP Report 350, Test Levels 2 and 3. The systems are provided in lengths and capacities for both low speed and high speed applications and hazard widths up to 8.5 feet [2.6m].

The Universal TAU-II system is redirective, non-gating, and is ideally suited for hazards such as the ends of rigid barriers, tollbooths, utility poles, and more. Ease of installation, numerous non-proprietary transition options, low maintenance requirements, very low life cycle costs and reusability of system components make the Universal TAU-II system ideal for treating many roadside hazards.

Redirective, non-gating crash cushions are high-

way safety devices whose primary function is to improve the safety for occupants of errant vehicles that impact the end of rigid or semi-rigid barriers or fixed roadside hazards by absorbing the kinetic energy of impact or by allowing controlled redirection of the vehicle. These devices are designed to safely decelerate an errant vehicle to a safe stop or redirect an errant vehicle away from roadside or median hazards. These types of systems are typically applied to locations where head-on and angled impacts are likely to occur and it is desirable to have the majority of post impact trajectories on the impact side of the system.

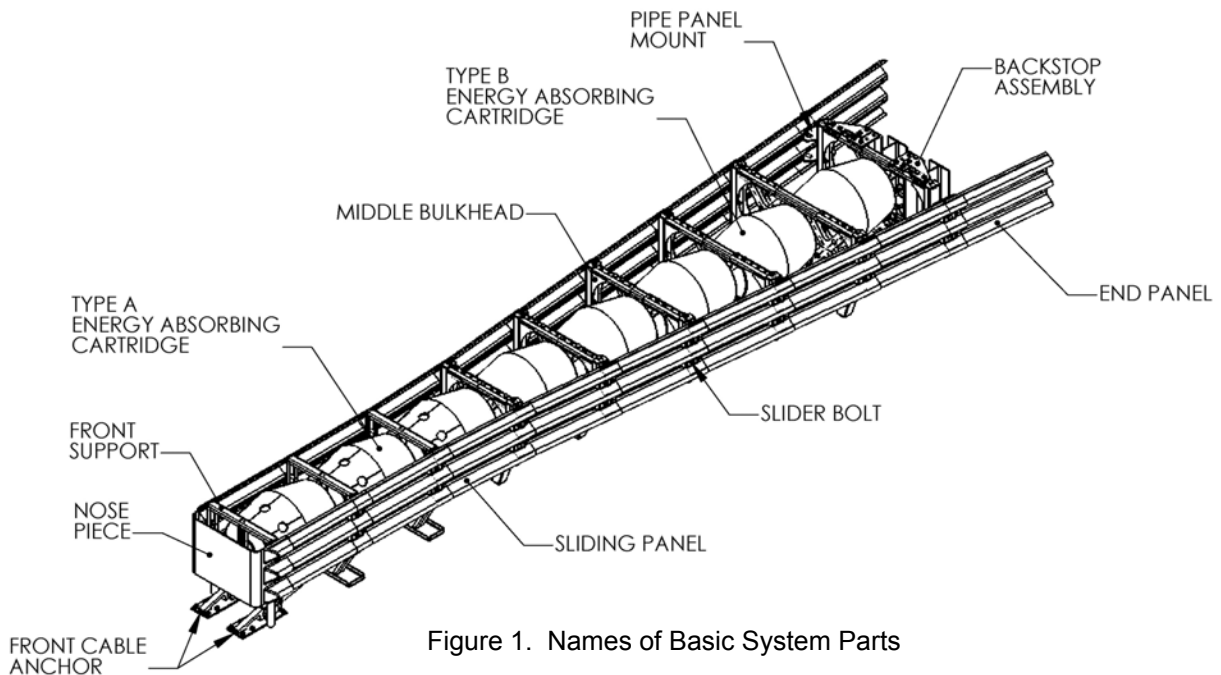

Figure 1. Names of Basic System Parts

SYSTEM OVERVIEW

The Universal TAU-II system is designed and constructed to provide acceptable structural adequacy, minimal occupant risk and safe vehicle trajectory as set forth in NCHRP 350 for redirective, non-gating crash cushions. Refer to Figure 1 to familiarize yourself with the basic parts and part names of the system.

The Universal TAU-II system is designed to shield the ends of median barriers and other fixed objects likely to be struck head-on, by absorbing and dissipating the kinetic energy of impacting vehicles. Universal TAU-II systems utilize disposable Energy Absorbing Cartridges (EACs) to absorb the kinetic energy of the impacting vehicle. The EACs are separated by diaphragms and held in place with a framework of three-beam corrugated steel rail panels that “telescope” rearward during head-on impacts. As the vehicle compresses the cushion, it exerts a force on the first bay containing an EAC. The diaphragms distribute the impact forces uniformly to all the remaining cartridges in each bay until the vehicle eventually stops. The depth of penetration is dependent upon both the original impact speed and the mass of the impacting vehicle. Only the Energy Absorbing Cartridges are expended after most head-on impacts.

When hit at an angle along the side, the system is restrained laterally by guidance cables that run the length of the system and attach to the bottoms of the diaphragms and terminate at the anchors at each end of the system. The front and rear cable anchors are attached to the foundation as described in Appendix “C” Foundation Requirements.

STEP 1

FOUNDATION REQUIREMENTS

The Universal TAU-II crash cushion is designed to be compatible with a variety of foundations. If an existing foundation is present, verify dimensions and system layout. If modification is required, use the BSI specifications as a guideline and adapt accordingly. If no foundation is present or currently does not meet the system requirements, construct the foundation per these BSI specifications.

There are different foundation configurations depending on the system used and the type of backstop selected. Systems up to 36" [910mm] can have a P.C.B. (Portable Concrete Barrier) Backstop, Flush Mount Backstop or a stand-alone Compact Backstop. PCB and Compact Backstop systems are compatible with the optional Asphalt Anchoring Kits. Systems 42" [1070mm] and greater use a Wide Flange Backstop and require a PCC (Portland Concrete) foundation and anchoring kit.

NOTE: Recommended maximum 8% cross slope on all foundation options.

Foundation options for all configurations are specified in the following drawings contained in APPENDIX "C", Page 47:

- General Foundation and Anchorage Specs.
Drawing No. A040113..... **Page 48**
- Universal TAU-II Foundation, **PCB Backstop**-PCC Concrete Pad:
Drawing No. A040105 **Page 49**
- Universal TAU-II Foundation **PCB Backstop**-PCC Block:
Drawing No. A040117 **Page 50**
- Universal TAU-II Foundation **PCB Backstop**-Asphalt Anchoring: Drawing
No. A040112 **Page 51**
- Universal TAU-II Foundation **Compact Backstop**-PCC Concrete Pad:
Drawing No. A040102 **Page 52**
- Universal TAU-II Foundation **Flush Mount Backstop**-PCC Pad:
Drawing No. A040420 **Page 53**
- Universal TAU-II Foundation

Compact Backstop-PCC Blocks: Drawing
No. A040115 **Page 54**

- Universal TAU-II Foundation **Compact Backstop**-Asphalt Anchor:
Drawing No. A040110 **Page 55**
- Universal TAU-II Foundation **Wide Flange Backstop**-PCC Concrete Pad:
Drawing No. A040108 **Page 56**
- Universal TAU-II Foundation **Dimensions – US Standard Units – Inches:**
Chart 1 **Page 57-59**
- Universal TAU-II Foundation **Dimensions – Metric Units – Millimeters:**
Charts **Pages 60-62**

Variations of these foundations may be reviewed and determinations made as to equivalence by the project engineer.

If you need additional information, or have questions about the Universal TAU-II Crash Cushion, please call the BSI Customer Service Department at (888) 800-3691 (U.S. toll free) or (707) 374-6800.

STEP 2

Anchor System to Foundation

With the proper foundation in place, anchor the Backstop, Rear Cable Anchors, and Front Cable Anchors according to the particular foundation detail (refer to Step 1).

The anchorage of the system must be in accordance with BSI foundation specifications found in Appendix “C”.

To anchor the Universal TAU-II system:

- 1.) Determine the backstop components and Front Cable Anchor positions about the centerline of the system. The foundation drawings show positioning.
- 2.) Using the actual parts as templates, either mark the holes to be drilled or drill through the parts acting as guides.
- 3.) Hole diameter and depth depends on the foundation and the anchoring compound used. See chart below for the hole diameter as specified by the anchoring compound manufacturer. Reference BSI Foundation and Anchorage Specifications in APPENDIX “C” for specific embedment depths.
- 4.) Prepare the holes as specified by the anchoring compound manufacturer.
- 5.) With the Front Cable Anchor and backstop components in place, apply the anchoring compound to the holes as specified by the manufacturer. Insert the anchors into the holes with the nuts and washers attached.
- 6.) Allow anchoring compound to cure before tightening the anchors.

The anchoring package supplied with the Universal

TAU-II system contains the necessary threaded rods and anchoring compound needed to install the system. Follow the instructions on the supplied package and reference the guidelines outlined below.

Anchor holes should be drilled using air-flushed or water-flushed rotary percussive drilling equipment. If diamond core or non-percussive drills are used, the hole must be thoroughly scoured using a coarse wire flue brush.

Other anchoring materials can be used if they comply with the following specifications: material should meet the ASTM C307 tensile strength of 2,000 psi (14 Mpa) and compressive strength of 10,000 psi (70 Mpa) per ASTM C109 or C579. The anchoring compound should provide a pull out strength of 20,000 lbf (89 kN) minimum in 4,000 psi (28 Mpa) concrete. Products such as HILTI HIT HY150 injection Adhesive Anchor, RE500 injection Adhesive Anchor or HVA Adhesive Anchoring System fit these criteria. Refer to Table 1 below for required hole size for recommended anchor compounds.

Mechanical / Removable Anchors

When standard chemical anchors cannot be used to secure Barrier System products as a result of state, local, site or other requirements, mechanical anchors may be used. Various mechanical anchors are available that use wedge, self-undercutting, or expansion coils to establish the locking bond with the concrete. A minimum of 18,000 lbf [80kN] ultimate load in the tension (pull out) and a shear of 22,000 lbf [98kN] is required for use with BSI products. One product recommended is the Hilti HCA item number 00252018 HCA 3/4” x 6”.

Torque anchors set in PCC concrete to 120 ft-lbf [160 N-m]. Torque anchors set in asphalt to 5 ft-lbf [8 N-m].

IMPORTANT: FOLLOW MANUFACTURER’S SPECIFICATIONS FOR HOLE SIZE AND PREPARATION

ANCHORING COMPOUND	HOLE DIAMETER
US Anchor Ultra Bond Speed Set	7/8” [22 mm]
HILTI - HIT HY 150	13/16” [20.5mm]
HILTI - HVA Adhesive Anchor System	7/8” [22 mm]
HILTI - RE 500	13/16” [20.5 mm] to 1” [25 mm]

STEP 3
Assemble Bulkheads

The Universal TAU-II is comprised of multiple bulkheads assembled to create a variety of different system lengths and widths. Systems are constructed with different bulkheads depending on the size of the system that is needed.

As illustrated in Figure 2, systems can be fully parallel, fully tapered or a combination. Every system requires a Front Support, a series of Middle Bulkhead Assemblies and a Backstop Assembly.

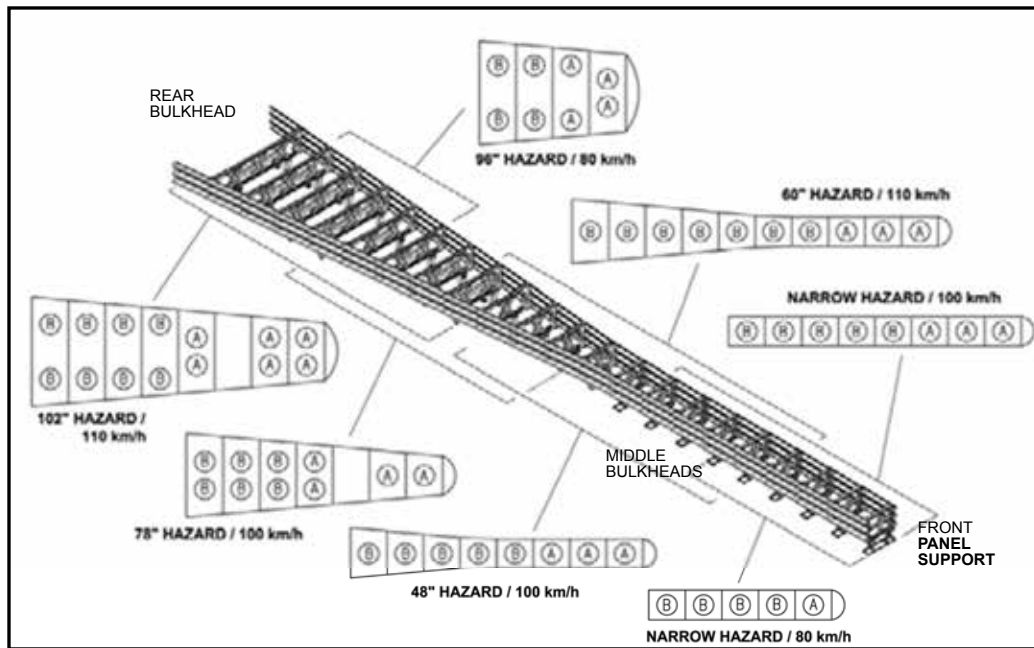
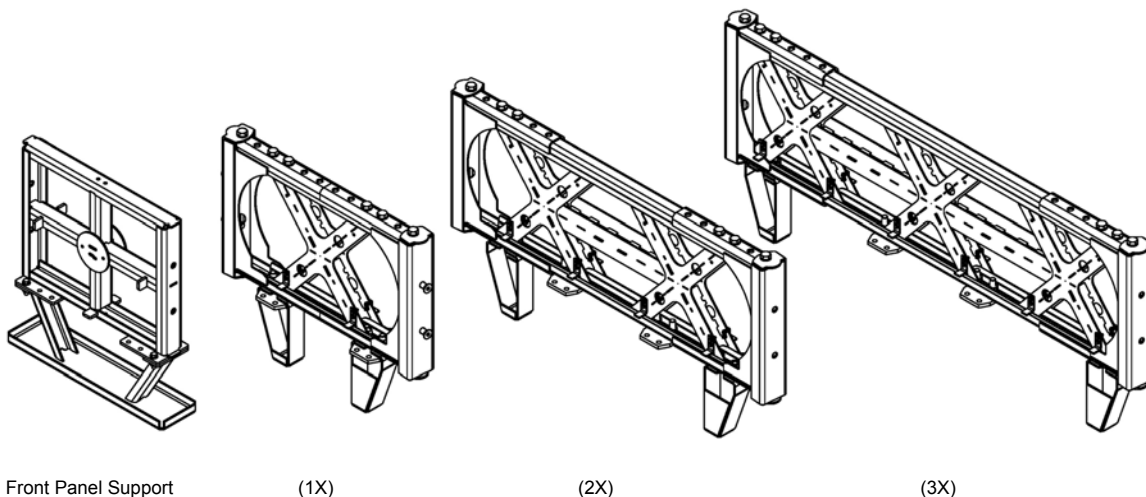

Figure 2.



Front Panel Support

(1X)

(2X)

(3X)

Figure 3. Middle Bulkheads

The Front Support

The Front Support is different from a bulkhead in that it has polymer front support Legs and it doesn't attach to the cables underneath the system. The Front Support also has metal plates called Collision Plates, attached in the impact area on the front of the assembly. The Front Support can be built in different variations depending on the system size.

*Using a Front Support:
(parallel and combination systems)*

Parallel and combination systems use the Front Support (Figure 4). A tapered system designed with a large nose section may use a modified 1X, 2X or 3X bulkhead for the Front Support (Figure 5).

The polymer front support legs bolt directly to the bottom of the Front Support using the hardware provided. All fasteners use a lock washer or Loctite.

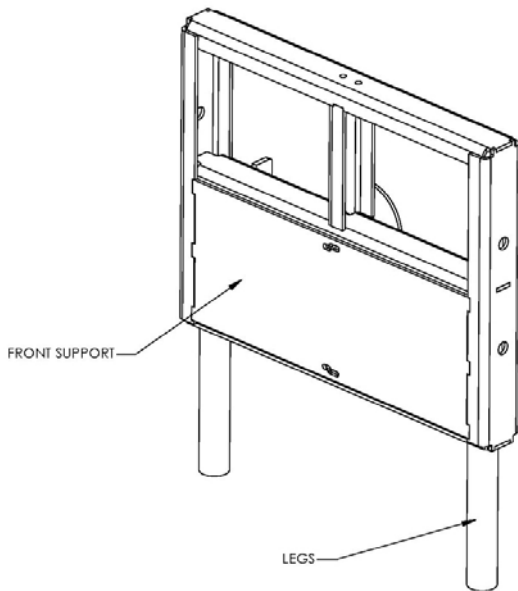

Figure 4. Use the Front Support for a parallel or combination systems.

**Using a modified Bulkhead for Front Support
(Tapered systems)**

An X style bulkhead can also be used as a Front Panel Support. The X style bulkheads are assembled according to the specific system requirements (Figure 5). Refer to the system drawing for the front bulkhead size needed. The Wing Assemblies slide over the ends of the bulkhead weldment and adjust to the width needed.

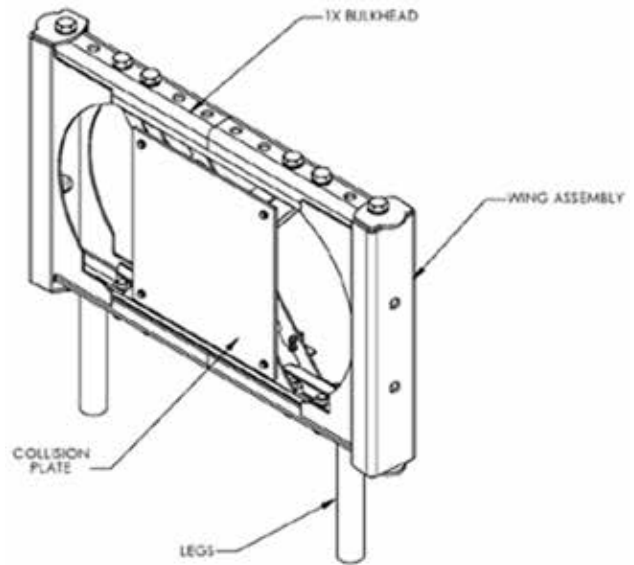

Figure 5. A 1X Style Middle Bulkhead converted into a Front Support

A Single X Bulkhead (1X) provides for Front Support widths of 30" [760] (using Transition Wing Assembly), 36" [910], 42" [1070], and 48" [1220].

A Double X Bulkhead (2X) provides for Front Support widths of 54" [1370], 60" [1525], 66" [1680], and 72" [1830].

A Triple X Bulkhead (3X) provides for Front Support widths of 78" [1980], 84" [2130], 90" [2290], and 96" [2440].

The Wing Assemblies are bolted in the appropriate location using Backing Plates and the hardware provided. All fasteners use a lock washer or Locktite (Figure 5).

The polymer front support legs bolt directly to the bottom of the assembly using free holes on the Wing Assemblies and the hardware provided (Figure 4,5). Some configurations require a leg adapter (Figure 6).

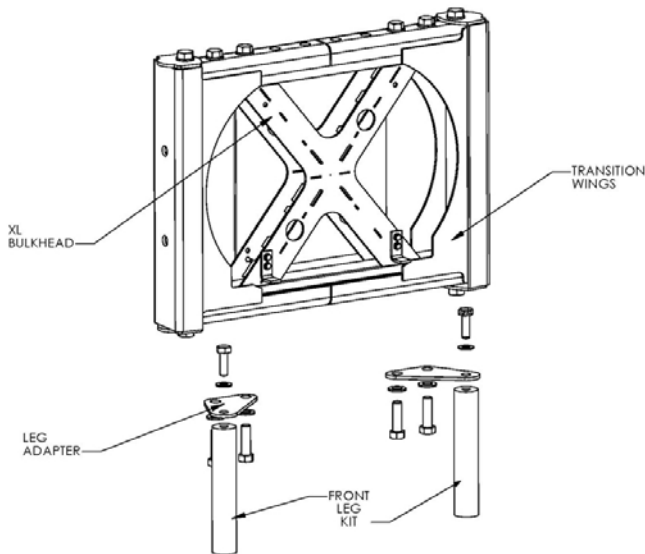

Figure 6. Leg Adapters

EAC Locating Tabs are bolted to the back of the assembly and Front Collision Plates are bolted to the front of the assembly. All fasteners use a lock washer and Locktite.

Middle Bulkhead Assemblies

The Middle Bulkheads come in two different styles: fixed and adjustable X-style. Depending on the system's cable location, the Cable Guide Mounting plates bolt to the bottom of the assembly at one of three positions.

Parallel Middle Bulkhead

The width of the Parallel Middle Bulkhead is not adjustable and is used in systems that are totally parallel or systems that start out parallel and finish with a rear taper (Figure 7).

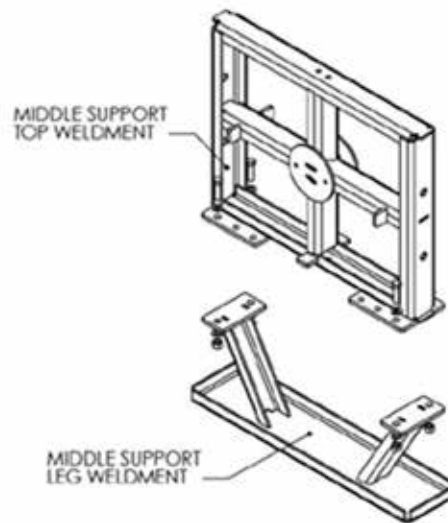

Figure 7. Parallel Middle Bulkhead

Adjustable Middle Bulkheads

The Adjustable Middle Bulkheads come in three different widths and are designated by the number of X patterns on the face of the bulkhead (Figure 3). The narrowest has a single X in its structure, the double X has two and the largest bulkhead has three X's.

All of the bulkheads have adjustable wings that are rigidly bolted on to each side (Figure 8). Using the adjustable wings, the different sized bulkheads can accommodate hazard widths up to 102" [2.6m]. The bulkheads can descend in 6" [150mm] increments until reaching the desired width.

The adjustable Middle Bulkheads are assembled according to the specific system requirements. Refer to the system drawing for the middle bulkhead sizes needed. The Wing Assemblies slide over the ends of the bulkhead and adjust to the width needed.

Single X (1) Middle Bulkheads provide for assembly widths of 30" [760] (using Transition Wing Assembly), 36" [910], 42" [1070], and 48" [1220].

Double X (2X) Middle Bulkheads provide for assembly widths of 54" [1370mm], 60" [1520mm], 66" [1680mm], and 72" [1830mm].

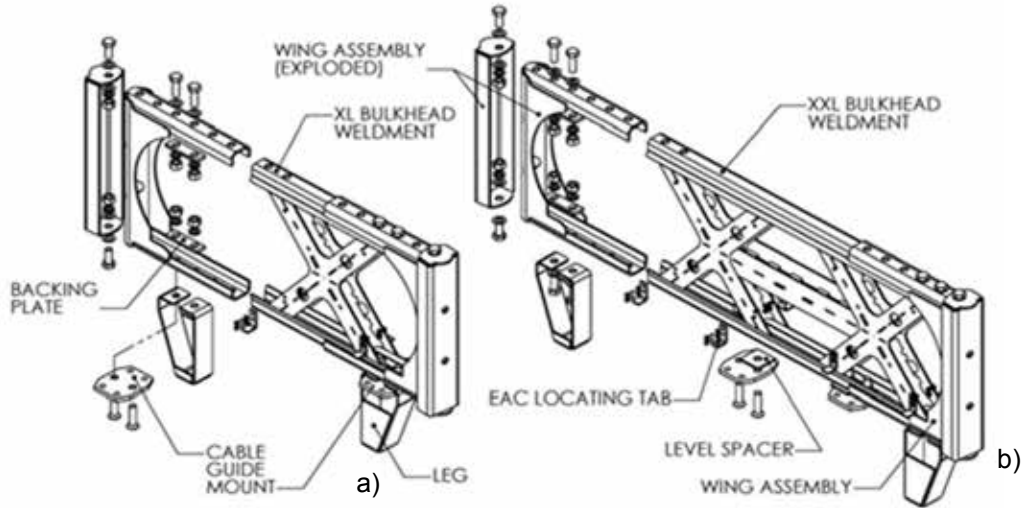

Figure 8. Adjustable Middle Bulkheads a) Single X (1X) b) Double X (2X)

Triple X (3X) Middle Bulkheads provide for assembly widths of 78" [1980mm], 84" [2130mm], 90" [2290mm], 96" [2440mm], 102" [2.6m].

The Wing Assemblies are bolted in the appropriate location using Backing Plates and the hardware provided. The Legs bolt directly to the bottom of the assembly where the Wing Assemblies attach using the same hardware. All fasteners use a lock washer or Loctite.

Cable Guide Mounts

If a parallel or 1X bulkhead is used as the Front Bulkhead Assembly, the cable is in the 1st position (Figure 9) and the Cable Guide Mounts would bolt in the corresponding location.
If a 2X or 3X bulkhead is used as the Front Bulkhead

Assembly, the cable is in position 2 or 3 (Figure 9) respectively and the Cable Guide Mounts attach accordingly. If said cable position aligns with the leg mounting position the Cable Guide Mount bolts through the leg using the hardware provided for the Cable Guide Mount.

Backing Plates are used on all Leg, Wing Assembly, and Cable Guide fastenings. A Level Spacer is used when attaching components across the step between the Bulkhead

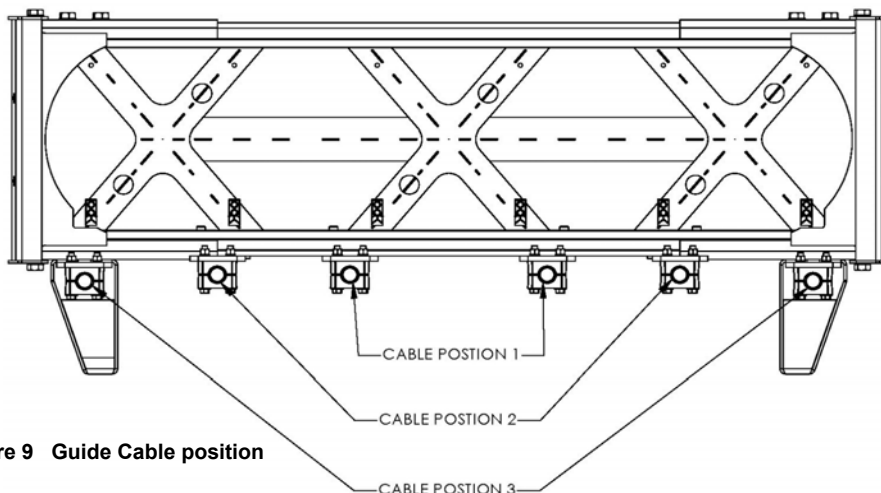

Figure 9 Guide Cable position

Weldment and the Wing Assembly.

EAC Locating Tabs

EAC Locating Tabs are bolted to the front and back of each Middle Bulkhead Assembly. All fasteners use a lock washer or Locktite (Figure 8).

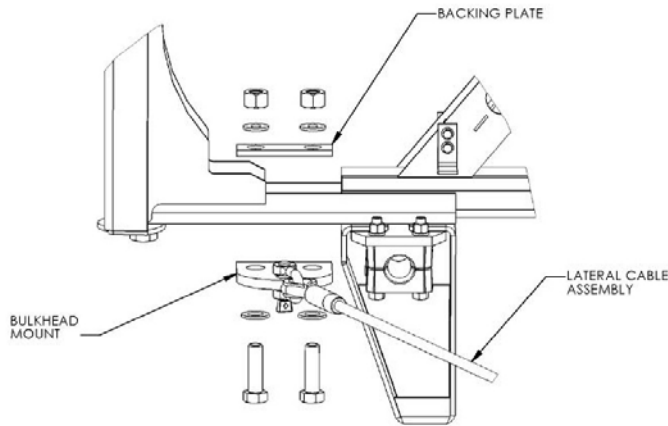

Figure 10. Lateral Cable Support

holes in the Wing Assemblies (Figure 10). They do fit inside the Legs if necessary (Figure 11).

NOTE: Refer to the System Configuration chart in Appendix “A” to determine if Lateral Cable supports are required.

Empty Bay Bumpers

Some systems require an empty bay (no Energy Absorbing Cartridges). These systems utilize a Bumper Kit to minimize damage in an impact (Figure 12). The kit includes (4) Bumpers that mount to the rear bulkhead assembly of the empty bay. Two Bumpers mount to the top of the assembly at the Wing to Bulkhead joint using the same hardware. The other two Bumpers mount through the Leg to the Wing – Bulkhead joint.

NOTE: Refer to the System Configuration chart in Appendix “A” to determine if empty bays are required.

Following complete assembly of the Front, Middle, and Backstop Bulkhead assemblies, position them in order. Space them at approximately 34” [860mm] apart, center to center. Also, align them through the center-line of the system. Accuracy and care taken here will improve ease of assembly and reduce efforts to straighten the system.

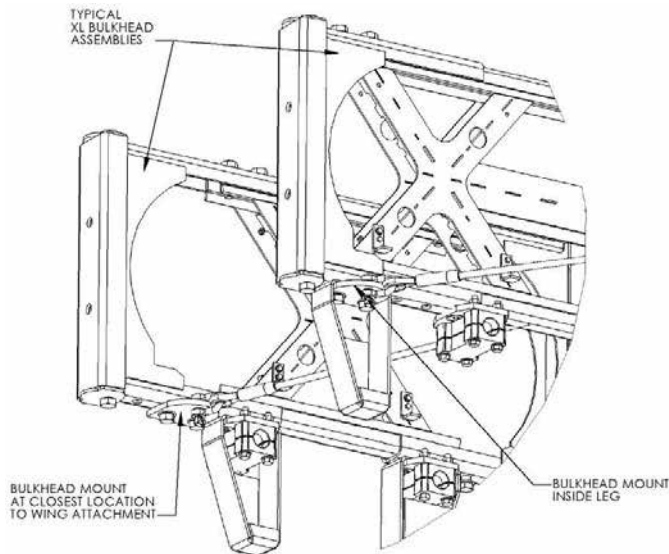

Figure 11. Lateral Cable Supports mounted inside and outside the leg

Lateral Cable Support

Some systems require a Lateral Cable Support Kit (Refer to Step 10 of this manual). The Lateral Cable Support Kit contains Bulkhead Mounts that attach to the last two bulkhead assemblies of required systems. They bolt to the outermost free

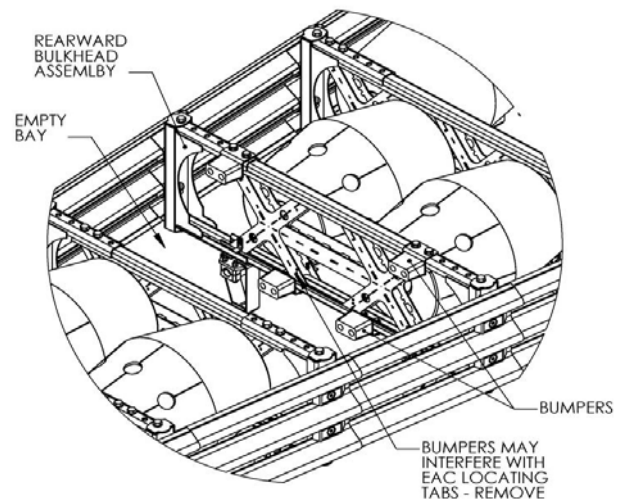

Figure 12 Empty Bay Bumpers

STEP 4

Backstop Assemblies

The Backstop Assembly is selected per application and can be configured to protect hazards up to 8.5' [2.6m] in width. Backstops can either be attached directly to a barrier wall or a suitable structure (Portable Concrete Barrier (PCB) Backstop, Flush Mount Backstop) or installed as a stand-alone system (Compact Backstop, Wide Flange Backstop). All backstops require minimum assembly if they are not pre-assembled.

PCB Backstop

The PCB Backstop (Figure 13) is configured from parts anchored directly to an existing concrete barrier wall. Refer to Step 1 and Step 2 for PCB Backstop layout and anchorage details. Pipe Panel Mounts bolt to the sides of the backstop and provide a mounting point for the Slider and End Panels.

Refer to the System Configuration Chart in Appendix "A" to determine system widths and Capacity Limitations.

If a 36" [910mm] Backstop is desired, attach the 36" [910mm] Backstop Adapters (Figure 14) to the sides of the backstops and bolt the Pipe Panel Mounts to the pivoting sections.

If the system is installed on an asphalt foundation, the portable concrete barrier must be anchored using the supplied brackets.

For additional information or questions about the Universal TAU-II Crash Cushion, please call the BSI Customer Service Department at (888) 800-3691 (U.S. toll free) or (707) 374-6800.

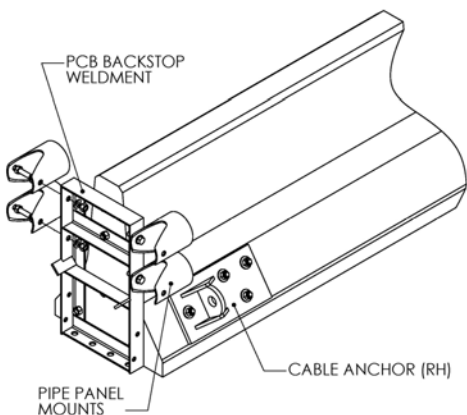

Figure 13 PCB Backstop (Parallel System)

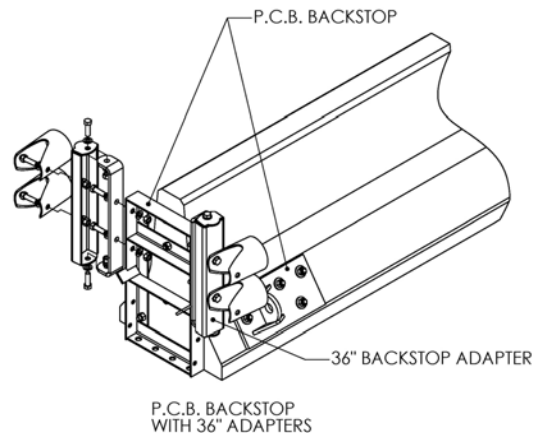

Figure 14 PCB Backstop (Tapered System)

Compact Backstop

The Compact Backstop (Figure 15) is bolted together in two halves and is usually pre-assembled. The Backstop is a stand alone design is not anchored to the hazard being protected.

Refer to Step 1 and Step 2 for Backstop layout and anchorage details.

Pipe Panel Mounts bolt to the sides of the backstop and provide a mounting point for the Slider and End Panels. Refer to the system drawing for the backstop assembly size needed.

If a 36" [910mm] Backstop is desired, attach the 36" [910mm] Backstop Adapters (Figure 16) to the sides of the backstops and bolt the Pipe Panel Mounts to the pivoting sections.

For additional information or questions about the Universal TAU-II Crash Cushion, please call the BSI Customer Service Department at (888) 800-3691 (U.S. toll free) or (707) 374-6800.

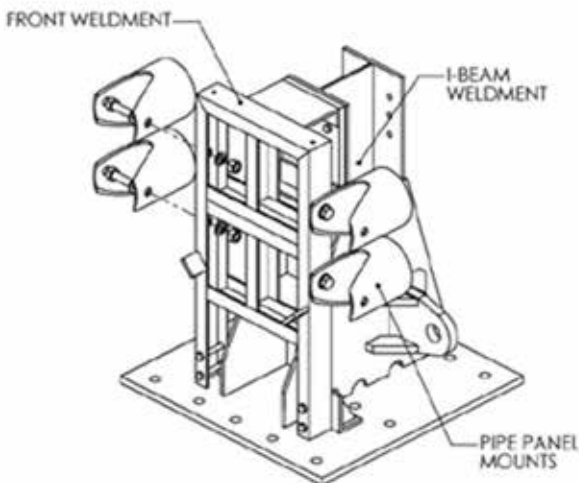

Figure 15 Compact Backstop (Parallel Systems)

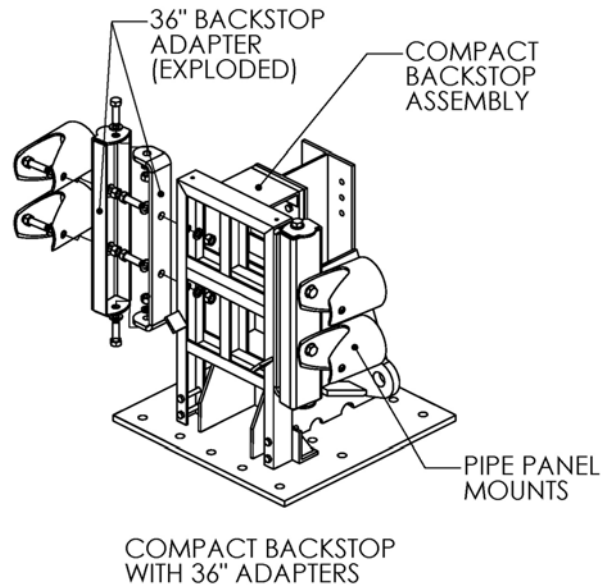

Figure 16 Compact Backstop (Tapered Systems)

Flush Mount Backstop

The Flush Mount Backstop system (Figure 17) is intended for applications where the hazard width exceeds the limitations of the PCB Backstop and are applicable in locations with limited foundation size. The Flush Mount Backstop can be attached to reinforced safety shape or vertical concrete structures up to 36" [910mm]. Systems over 24" [610mm] wide require the 36" [910mm] adapter. Edges of vertical concrete may require chamfer according to local standards.

The Cable Tensioning is moved to the front of the system so the rear cable anchors do not protrude outside of the rear extension panels.

The backstop is attached to the foundation and to the concrete backstop. Install anchors in accordance with BSI specifications. Vertical slots on the backstop allow removal replacement of the backstop. Anchors must be placed at the top of said slots to be effective. Flush Mount Backstop systems use the same cable used in all parallel systems. The cable is installed with the threaded tensioning end forward. The looped end is pinned in place at the backstop. The Front Cable Anchor uses an inserted key to keep the threaded stud from rotating during tensioning.

For additional information or questions about the Universal TAU-II Crash Cushion, please call the BSI Customer Service Department at (888) 800-3691 (U.S. toll free) or (707) 374-6800.

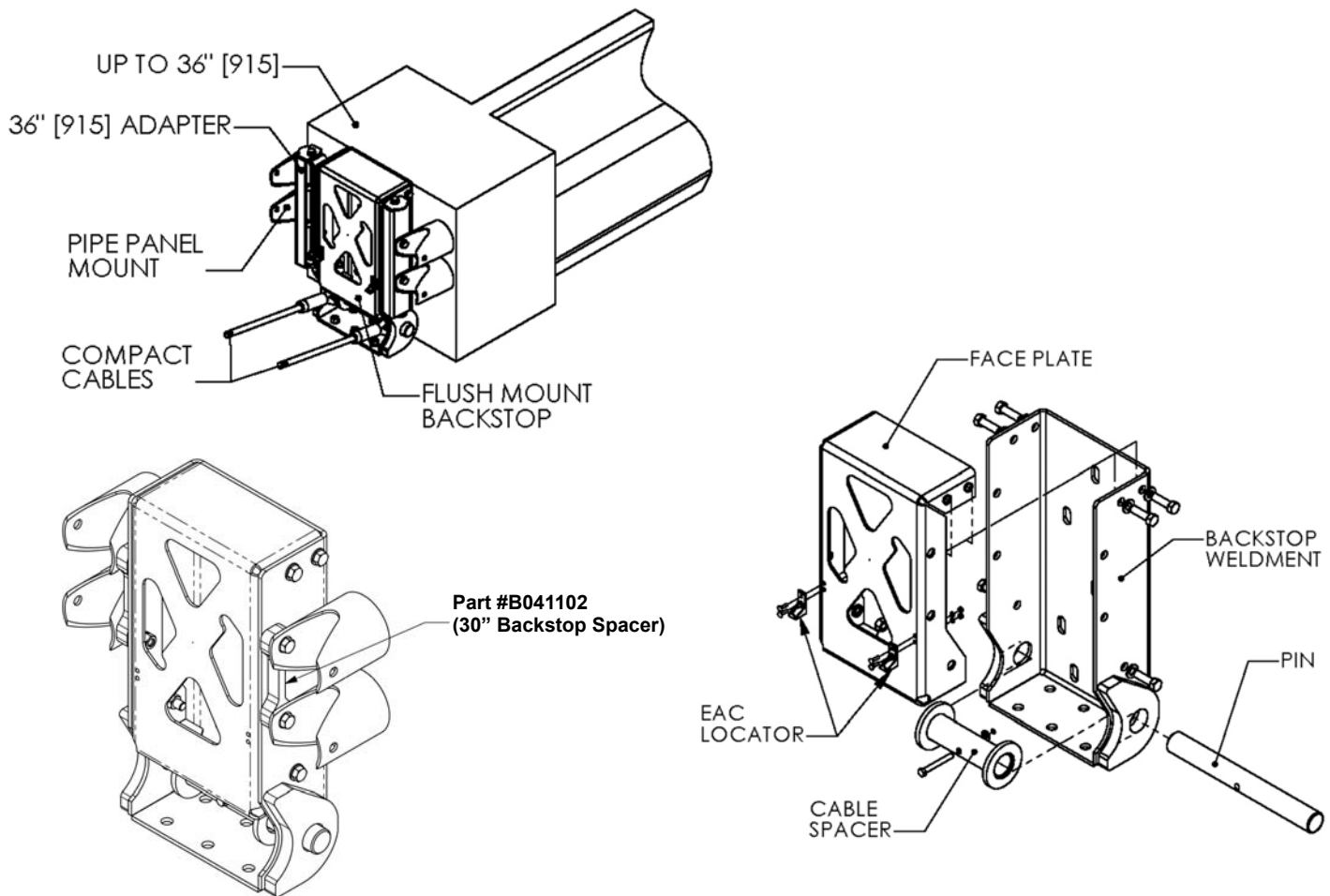

Figure 17 Flush Mount Backstop

Wide Flange Backstop

The Wide Flange Backstop (Figure 18) uses a combination of backstop elements to protect wide hazards.

The Wide Flange Backstop incorporates XL, XXL, or XXXL bulkhead assemblies attached to two Wide Flange Backstop Weldments.

The backstop bulkheads are assembled according to the specific system requirements. The Wing Assemblies slide over the ends of the bulkhead weldment and adjust to the width needed.

XL Bulkheads provide for backstop bulkhead assembly widths of 42" [1070] (using Transition Wing Assembly), 48" [1220], 54" [1370], and 60" [1525].
 XXL Bulkheads provide for backstop bulkhead

assembly widths of 66" [1680], 72" [1830], 78" [1980], and 84" [2130].

XXXL Bulkheads provide for backstop bulkhead assembly widths of 90" [2290], 96" [2440], and 102" [2290].

Backstop Block-outs mount to the bulkhead assemblies at the Wing Assembly to Bulkhead Weldment joint. The block-outs are bolted through the Wing Assemblies and bulkhead weldment and fastened using Backing Plates and the hardware provided. The bulkhead assembly and block-outs are then bolted to the Wide Flange Backstop Weldments. Pipe Panel Mounts are fastened to the pivoting section of the Wing Assemblies. EAC Locating Tabs bolt to the front of the bulkhead assembly. All fasteners use a lock washer or Locktite.

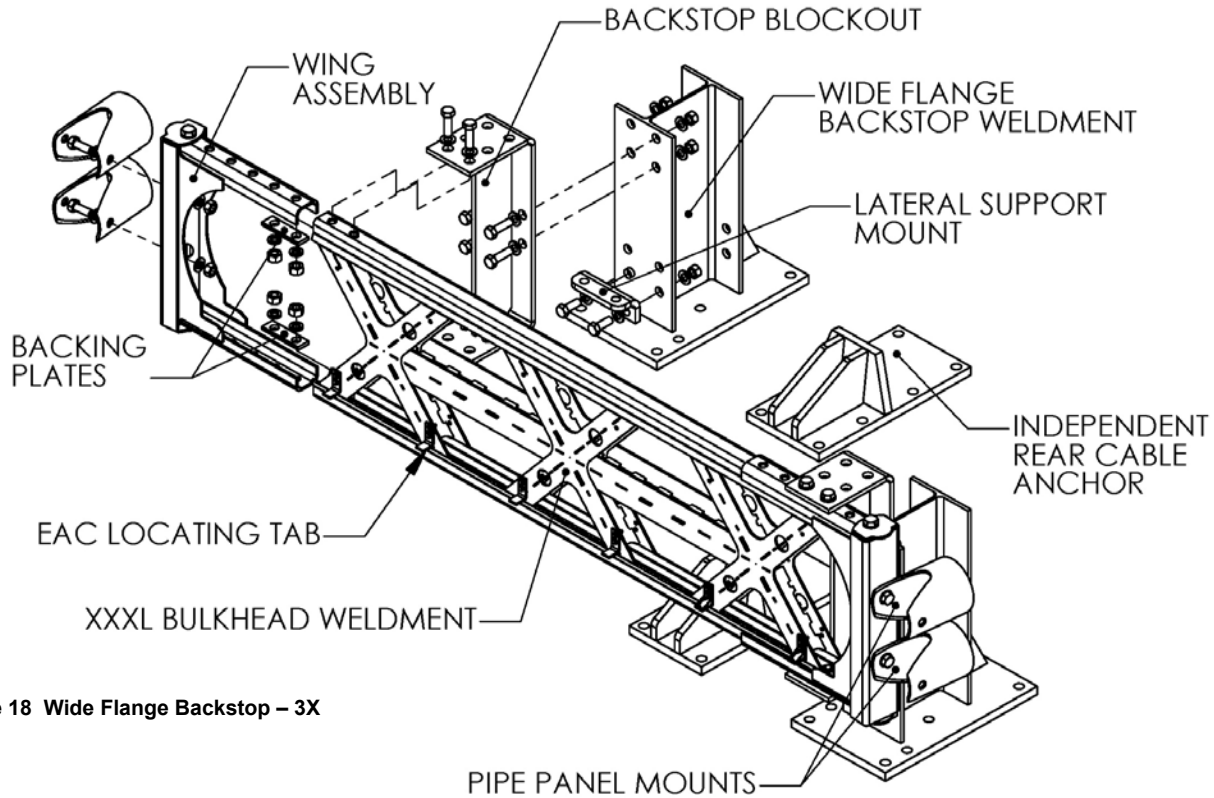

Figure 18 Wide Flange Backstop – 3X

Depending on the position of the cables in reference to the Wide Flange Backstop positioning, either an independent rear cable anchor (Figure 18) or a backstop mounted rear cable anchor (Figure 19) will be used. The independent rear cable anchor stands alone and requires no assembly. (Reference Step 1 and Step 2 for layout and anchorage specifications). The backstop mounted rear cable anchor bolts between the flanges of the Wide Flange Backstop. They are mounted to the interior of the system. All fasteners use a lock washer or Locktite. When the front support bulkhead and backstop utilize the same bulkhead, the rear cable anchors are mounted to the backstops. When the front support bulkhead and backstop bulkheads are different, the system is supplied with independent rear cable anchors mounted on the pad surface.

Some systems require a Lateral Cable Support Kit. The Lateral Cable Support Kit contains Lateral Support Mounts that attach to the backstop assembly of required systems. They bolt to the front of the Wide Flange Backstop Weldments in the lowest hole set. If backstop mounted rear cable anchors are used, one of the bolts will be shared. All fasteners use a lock washer or Locktite.

Refer to the System Configuration Chart in Appendix "A" to determine if Lateral Cable supports are

required.

If the Wing Assemblies of the particular backstop are adjusted to one of their two most extended positions (54" [1370mm], 60" [1525mm], 78" [1980mm], 84" [2130mm], and 102" [2290mm] backstops), Wing Braces and Spacers are required (Figure 19). The Wing Braces attach to the Wing Assemblies and the Backstop Block-outs on the top and bottom. The Spacers level their mounting surfaces. All fasteners use a lock washer or Locktite.

For additional information or questions about the Universal TAU-II Crash Cushion, please call the BSI Customer Service Department at (888) 800-3691 (U.S. toll free) or (707) 374-6800.

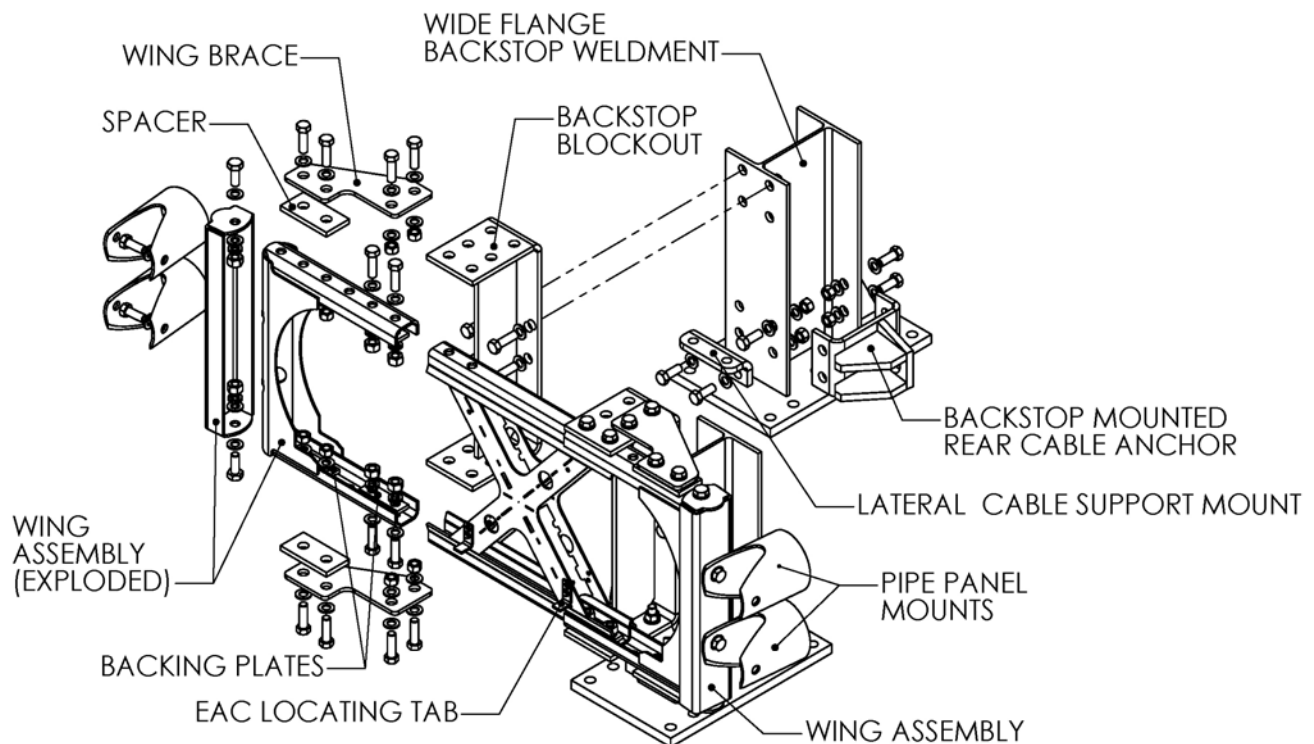

Figure 19 Backstop – 1X with Wing Braces

STEP 5

Attach Panels

The Universal TAU-II system uses two types of panels: Sliding Panels (Figure 20) and End Panels (Figure 21). Sliding Panels have a pair of holes forward and two long slots running the length of the panels. End Panels have a pair of holes at each end and do not have slots. Sliding panels are used on all collapsing bays. End panels are attached to the backstop only (Call BSI for non-proprietary transition options). Slider Bolts hold the panels to the bulkheads. Some systems require nested panels (doubled) on rearward bays.

NOTE: Refer to the System Configuration Chart in Appendix "A" to determine if/where nested panels are required. A long bolt is supplied to assist in the assembly to nest the panels.

Install the panels from back to front staggering from each side. Place the End Panels first. While holding the End Panel in place, lap the forward Sliding Panel over it and bolt through the slot, End Panel, and Pipe Panel Mount (Figure 22). Leave the nuts of the Slider Bolts loose and perform on both sides. Lap the next forward Sliding Panel and bolt through the slot, hole set in rearward Sliding Panel, and bulkhead. Leave the Slider Bolt nuts loose and progress forward alternating sides (Figure 23). If the bay requires nested panels, perform procedure with (2) panels, one nested inside the other.

The last panels to be installed will be on the first bay of the system, the Front Support. These panels lap the rearward panel and fasten to the 2nd bulkhead from the front as instructed above. The front of these panels will mount to the Front Support through the Nose Piece. Refer to Section 6 for this connection (Figure 26).

Leave the Slider Bolt nuts loose until the system is almost completely assembled and installed.

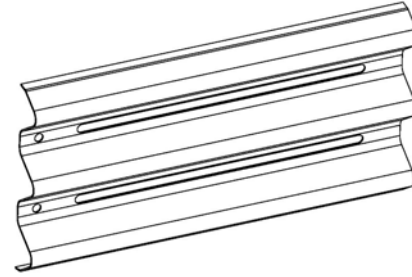

Figure 20 Slider Panel

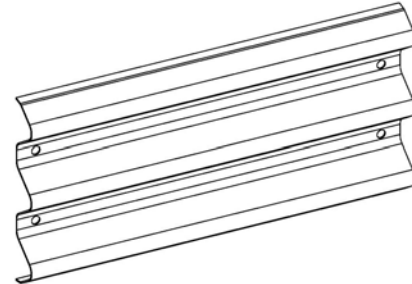

Figure 21 End Panel (no slots)

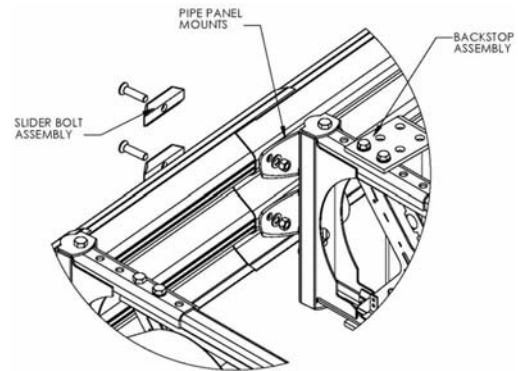

Figure 22 Attach Rear Panel

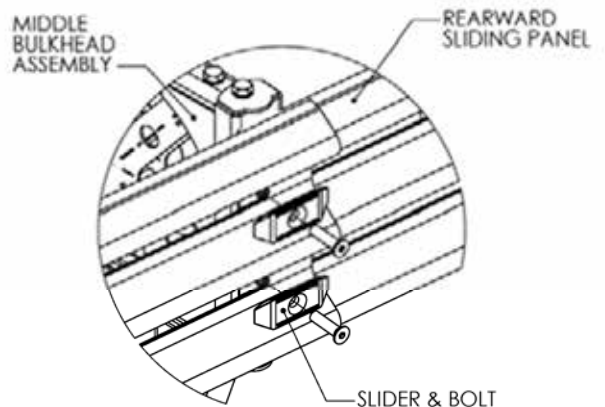

Figure 23 Attach Side Panels

STEP 6

Attach Nose Piece / Delineation Marker

Narrow systems (up to 36" [910mm] Front Support) use a one-piece polyurethane nose (Figure 24) with molded three beam corrugations on both ends. Wider Front Support Assemblies (42" [1070mm] and above) use two polyurethane parts (Figure 25) riveted together. The two part nose pieces have three beam corrugations on one side and a series of holes through the flat section. Guide Cable Torque

The Nose Piece attaches to the Front Support assembly through the Sliding Panels (Figure 26). Thick flat round washers are inserted in the mounting holes of the nose piece to limit compression of the polyurethane. Two 3/4" [20mm] bolts with fender washers clamp the nose piece and Sliding Panel to the Front Support on each side. Fasteners use lock washers or Lockite.

Torque to 200 ft-lbf [270 N-m].

The two part nose pieces overlap across the width of the system. Adjust to desired profile and align holes. Using the supplied pop-rivets and washers, rivet two columns of holes. Rivets should pass through the overlapping nose pieces at the furthest possible columns apart (Figure 26).

Apply delineation markings as required (not supplied).

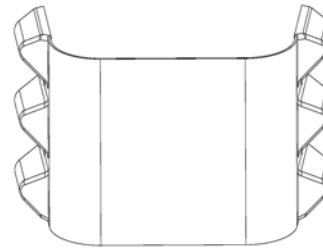

Figure 24 Nose Piece (up to 36")

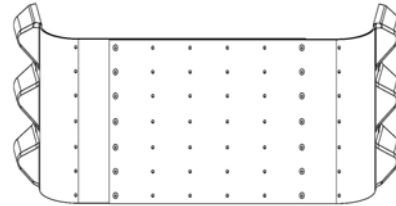

Figure 25 Nose Piece (wide)

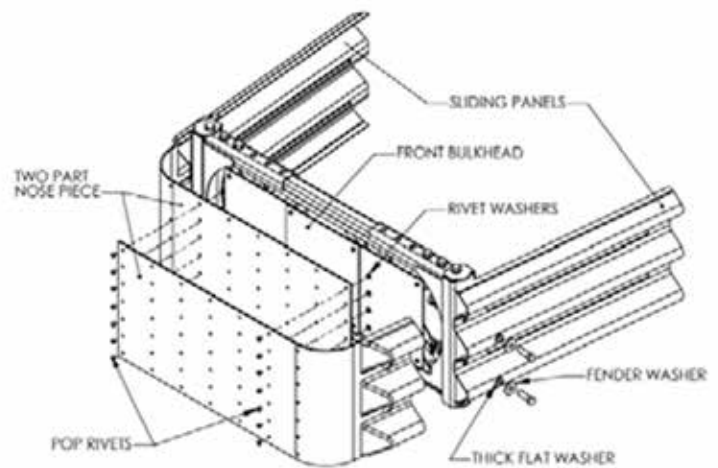

Figure 26 Wide Nose Piece Assembly

STEP 7

Install Cables and Cable Guides

Cable Location

Every system has a set of cables that run through the cable guides that attach underneath each bulkhead. The Cable Guides clamp around the cable and bolt to the bottom of the bulkheads. The Cable Guide is universal and fits all bulkhead and cable configurations. Two Cable Guide assemblies are used on every middle bulkhead assembly (Figure 27).

The cables are tensioned between the Backstop and Front Cable Anchor. The Front Cable Anchor is mounted under the first bay.

IMPORTANT NOTE: The Front Support Assembly is not attached to the cable.

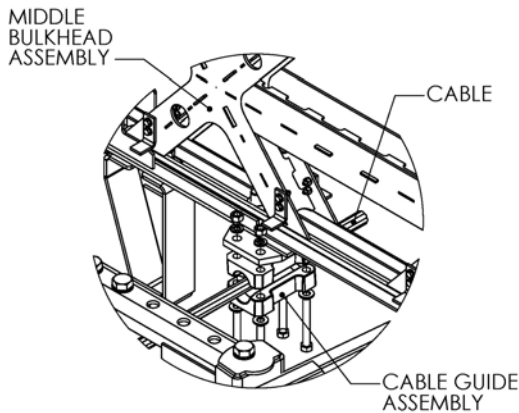

Figure 27 Cable Guide Clamp

Systems using a PCB, Compact Backstop or Flush Mount Backstop.

Systems using a PCB, Flush Mount or Compact Backstop use 1" [25mm] diameter cable (Figure 28). These Cables are identified by the loop and shackle on one end and a threaded stud swaged to the other end. (The shackle is not used on the Flush Mount Backstop).



Figure 28 Compact Cable

Systems with Wide Flange Backstops

Systems with Wide Flange Backstops use a 1 1/8" [28mm] diameter cable (Figure 29). These cables have a threaded stud swaged to the rear end and a large "open swage socket" on the front end. A Key is also included which limits rotation of the cable during tensioning at the Rear Cable Anchor.

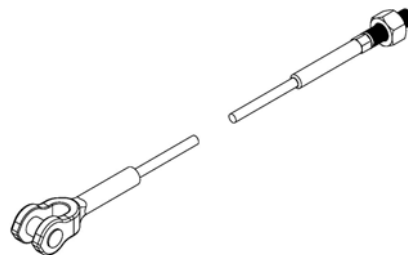

Figure 29 Universal Cable

The cables are fed through the bulkheads from the front. On parallel style bulkheads, the cables thread between the legs. On XL-XXXL bulkheads, the cables can go between the legs or through the legs, depending on the configuration. Lead with the rear of the cable. Place the rear cable end through the Rear Cable Anchor, PCB Backstop, or Compact Backstop. Start the tensioning nut with about 1" [25mm] of thread.

Without pinning the Front Cable Anchor, attach the Cable Guides to the bulkheads. Start from the last bulkhead and move forward. Cable Guides attach with ½" [12mm] hardware provided. Fasteners use lock washers or Locktite.

When all the Cable Guides are installed, pin the front cable end to the Front Cable Anchor. On Wide Flange Backstop configurations, install the Key to the Rear Cable Anchor (Figure 30).

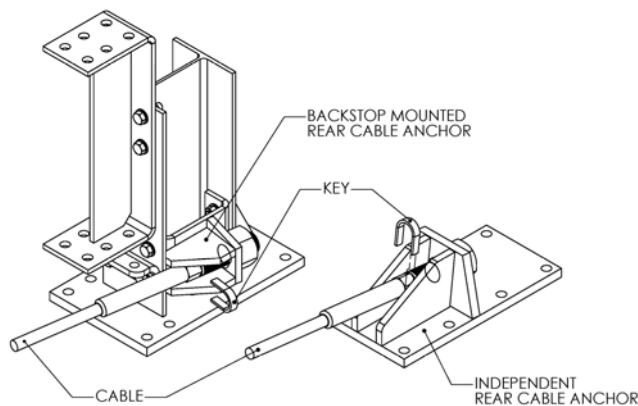

Figure 30 Backstop Cable Mount

STEP 8

Stretch and Align the System

This step can be avoided or reduced if care is taken to align and space the bulkheads properly during assembly.

Attach a pair of chains or straps to the Front Bulkhead assembly. Using a truck or other tow vehicle, pull the system forward to fully extend the bays. The bays are fully extended when the Slider Bolts are bottomed out in the slots of the Sliding Panels.

If necessary, bump or nudge the system into alignment. Each bulkhead should be aligned along the centerline of the system.

Recommended attachment points for straps or chains are at the corners of Front Support on the top and bottom horizontal channels. When attaching to XL-XXXL bulkheads, secure as close to the Wing Assembly attachment points as possible.

NOTE: Be sure not to jerk or pull on the backstop anchors before the anchoring compound has cured and the backstop is secured to the foundation.

STEP 9

Tension Cables and Torque Slider Bolts

Tension the Cables. Torque the cables in 50 ft-lbf [65 N-m] increments alternating between the two. Reference Torque Chart below (Table 2) for torque requirements. Use the deep socket provided.

Tighten Slider Bolts to approximately 100 ft-lbf [130 N-m], loosen, and then torque to 20 ft-lbf [27 N-m]. This procedure ensures proper nesting of the panels and torque accuracy.

NOTE: Care must be taken to not over tighten the sliders. Follow the procedure outlined above.

STEP 10

Install Lateral Support Cables

Skip this section if the system does not require a Lateral Cable Support Kit.

NOTE: Refer to the System Configuration chart in Appendix "A" to determine if Lateral Support Cables are required.

If the system requires a Lateral Cable Support Kit, the cable mounts should be installed on the last two bulkhead assemblies and the Wide Flange Backstops. Refer to Figure 9 and Figure 10 of Step 3.

The Lateral Support Cables are 1/2" [12mm] diameter and have a 1/2" [12mm] shackle on one end. There are eight (8) cable assemblies in the kit. The shackles pin to the cable mounts on the bulkheads and Wide Flange Backstops (Figure 31, 32, 33, 34, 35). The two cables from each backstop are routed to the opposite sides of the last two bulkheads (Figure 35).

These cables are attached to the cables pinned to the bulkheads with cable clamps. Six cable clamps are used in series of three. Place the clamps at the furthest extents of the overlapping cables. The first cable clamp should be approximately 3" [75mm] from the cable end. Subsequent clamps should be spaced at 3" [75mm] (Figure 33).

Cables should be taught with minimal slack, but do not require tensioning. Routing above or below the main system cables is acceptable. Bundle access cable and use provided plastic wrap ties to secure the bundles to the suspended cables.

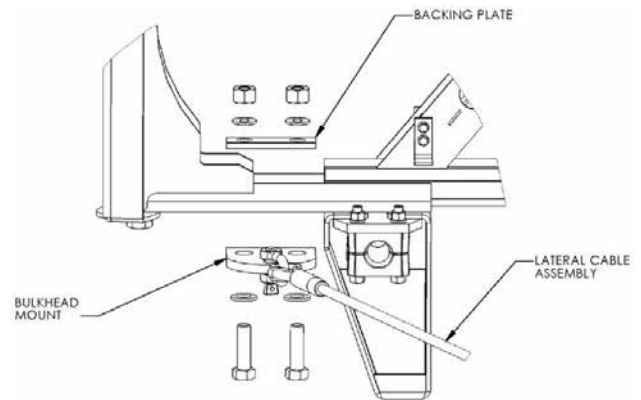

Figure 31 Lateral Support Cable

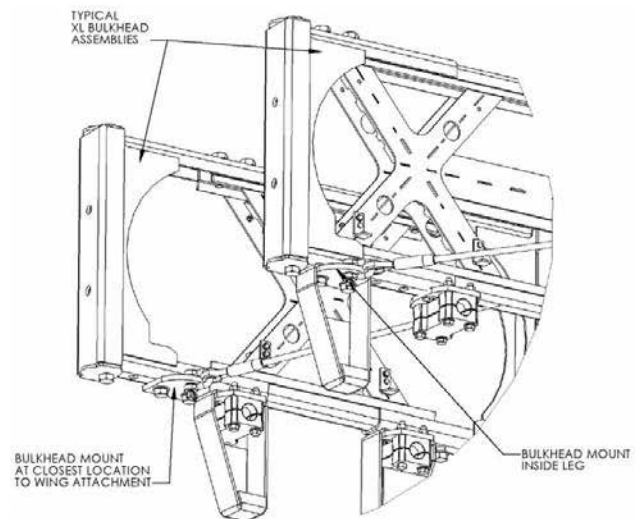

Figure 32 Lateral Support Cables

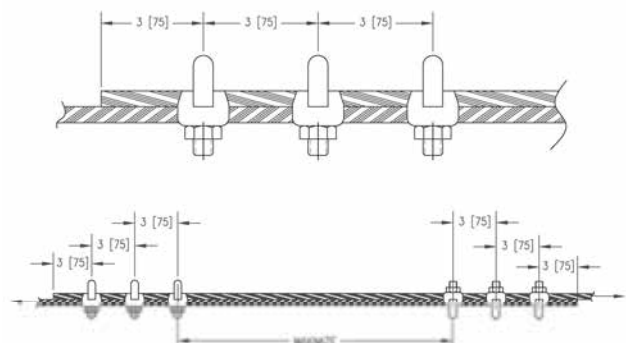

Figure 33 Install Cable Clamps

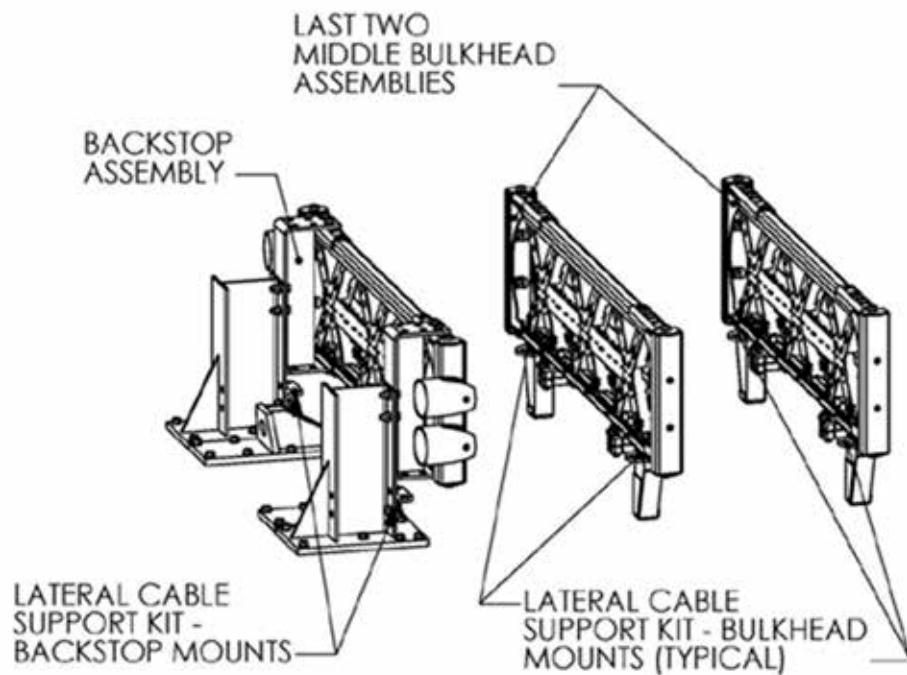

Figure 34 Cable Mounts

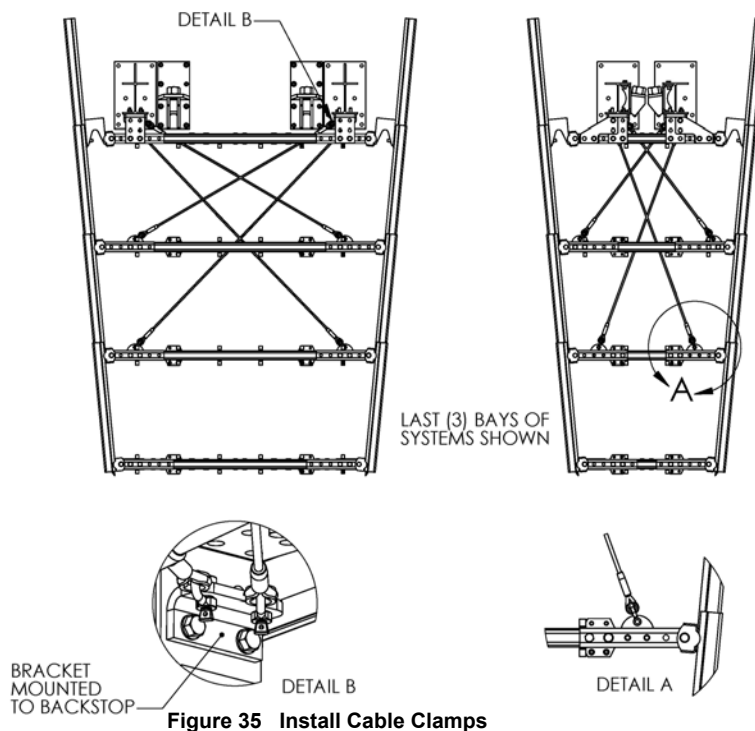

Figure 35 Install Cable Clamps

STEP 11

Insert Energy Absorbing Cartridges

There are two types of Energy Absorbing Cartridges (EAC). Each EAC has a forward and rearward end. Type “A” EAC’s (Figure 36) have eight (8) 3” [75mm] diameter holes around the circumference of the front half of the cylinder. Type “B” EAC’s (Figure 37) have a solid cylinder wall with three (3) vent holes on the rearward end.

When installing the EAC’s in a system it is important to ensure that they are placed according to manufacturer specification.

NOTE: Refer the System Configuration Chart in Appendix “A” for proper EAC placement.

When placed in the system, the front of the EAC will face the front of the system (narrow end). Text on the EAC reading “This Side Up” should be legible and at the top of the inserted EAC. The EAC should rest on the EAC Locating Tabs.

Note that bays capable of holding (2) EAC’s will always use (2) EAC’s except in specified empty bays. They will also always be placed in the widest locations available.

NOTE: A single bay will never have more than (2) EAC’s in it. Refer the System Configuration Chart in Appendix “A” for proper placement.

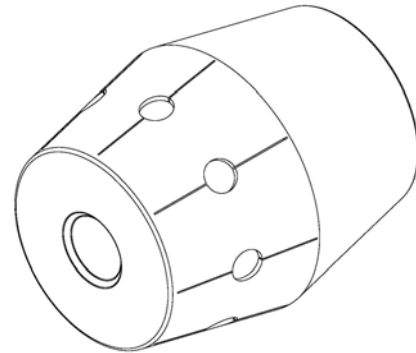

Figure 36 Energy Absorbing Cartridge – Type A

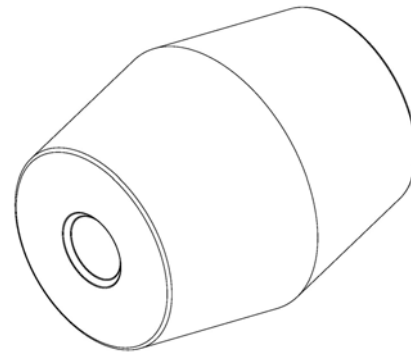

Figure 37 Energy Absorbing Cartridge – Type B

STEP 12

Final Inspection

Use the check list below to confirm that all of the installation steps have been completed.

Inspection Date	Inspection By:	Item
		All front cable anchor plate and backstop anchor bolts in place and epoxy cured.
		Clevis and pin, mounted to the front cable anchor, is installed with the handle portion of the pin on the inside of the anchor assembly, firmly tightened. <i>(This may be different depending on the type of foundation, ie, asphalt or PCC.)</i>
		All cable guide assemblies securely fastened.
		System cables tightened to meet torque specifications.
		Pipe panel mounts positioned properly, flat end facing back, cut out facing forward.
		Sliding panels installed properly to allow for stacking.
		Sliding panels should have no more than a 3/4" (19mm) gap between stacked panels.
		Nose cover properly installed with thick spacer and tightened to specifications.
		Torque Sliding Bolt assemblies to specifications. Do NOT over tighten.
		Energy Absorbing Cartridges (EAC) installed in proper A-B position and sequence. See Configuration Chart.
		EAC air discharge holes positioned properly. Rotate cast ID to the top of the cartridge.
		Asphalt adapter installed on both sides of portable concrete barrier when applicable.
		Torque all fasteners to meet specifications.

APPENDIX A - System Configuration Chart

	30 mph* [50 km/h]	35+ mph* [60 km/h]	44 mph [70 km/h] Test Level -2	50 mph* [80 km/h]	53 mph [85 km/h]	55 mph [90 km/h]
Up to 30" [700 mm]						
36" [900 mm]						
42" [1060 mm]						
48" [1220 mm]						
54" [1370 mm]						
60" [1520 mm]			X	X		X
66" [1680 mm]			X	X		X
72" [1830 mm]			X	X		X
78" [1980 mm]			X	X		X
84" [2130 mm]			X	X		X
90" [2290 mm]			X	X		X
96" [2440 mm]			X	X		X
102" [2600 mm]						

BACKSTOP WIDTH

Legend:

- X Lateral Support Cables Required
- Double Slider Panels
- Single Slider Panel
- ┌ Leg Adapter Required
- Single X Bulkhead (XL)
- Double X Bulkhead (XXL)
- Triple X Bulkhead (XXXL)
- Parallel Diaphragm
- Nose Piece
- A Type A Energy Absorbing Cartridge
- B Type B Energy Absorbing Cartridge
- Transition Wing Assembly Required
- ⊗ 36" Adapter Assembly Required
- Wide Nose Piece

* Speed Capacity rounded down to nearest 5 mph level. Contact Customer service for further information.

	60+ mph* [100 km/h] Test Level - 3	65 mph [105 km/h]	70 mph [110 km/h]
Up to 30" [760 mm]			
36" [910 mm]			
42" [1060 mm]			
48" [1220 mm]			
54" [1370 mm]			
60" [1520 mm]	X	X	X
66" [1680 mm]	X	X	X
72" [1830 mm]	X	X	X
78" [1980 mm]	X	X	X
84" [2130 mm]	X	X	X
90" [2290 mm]	X	X	X
96" [2440 mm]	X	X	X
102" [2600 mm]			X

ADDITIONAL HIGHER SPEED SYSTEMS

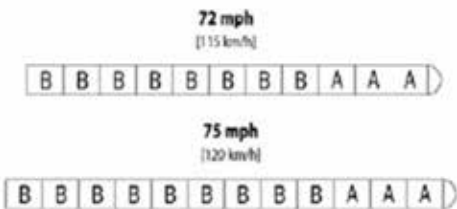

Call or email BSI Customer Service:
 888 800-3691 (U.S. Toll Free)
 707 374-6800 (Outside U.S.)
 email: rkoener@barriersystemsinc.com

Visit our website at
www.barriersystemsinc.com
 An ISO 9001:2000 Company

APPENDIX B - System Torque Chart

CONCRETE INSTALLATION

Compact Backstop Anchors.....	120 ft-lbs (160 N-m)
PCB Backstop Anchors.....	120 ft-lbs (160 N-m)
Cable Anchor (Rear).....	120 ft-lbs (160 N-m)
Cable Anchor (Front).....	120 ft-lbs (160 N-m)
Cable Adj. Eye Bolt.....	500 ft-lbs (675 N-m)

ASPHALT INSTALLATION

Compact Backstop Anchors.....	5 ft-lbs (8 N-m)
PCB Backstop Anchors.....	5 ft-lbs (8 N-m)
PCB Asphalt Adapter	5 ft-lbs (8 N-m)
Cable Anchor (Front).....	5 ft-lbs (8 N-m)
Cable Adj. Eye Bolt.....	120 ft-lbs (160 N-m)

SYSTEM COMPONENT INSTALLATION

Sliding Bolt Assembly.....	20 ft-lbs (27 N-m)
Front Panel Holding Nose Cover.....	200 ft-lbs (270 N-m)
Pipe Panel Mount to Backstop.....	70 ft-lbs (95 N-m)
Cable Guide Bolts	30 ft-lbs (48 N-m)

The Universal TAU-II Crash Cushion has been successfully tested in various configurations having the cable torque ranging from 120 ft-lbs for asphalt installation, to 500 ft-lbs of torque for concrete applications. The system will function properly under this full range of torque. If a torque wrench is not available, refer to the table below for an alternate method of reaching the desired torque range.

Ways of creating approximately 500 ft-lbs of torque:

- 6 ft. [1.8 m] wrench extension with entire weight of 100 lbs [45 kg] applied 12” from the end
- 42 in. [1.1 m] wrench extension with entire weight of 200 lbs [90 kg] applied 12” from the end
- Use free weights or human weight

These methods should ensure torque within tested range and manufacturer tolerances.

APPENDIX C

Anchoring Foundation Options

There are three approved anchoring foundation configurations for the TAU-II system. The first method utilizes a solid concrete pad over the length of the system. The second utilizes concrete blocks at the Backstop and Front Cable Anchor locations. The third is on Asphaltic Concrete foundation.

(Variations of these foundations may be reviewed and determinations made as to equivalence by the Project Engineer.)

There are different foundation configurations depending on which backstop you are using (Compact or P.C.B.). Foundation options for both of the Backstop systems are shown in the following drawings.

DRAWINGS

Foundation Specifications	48
DWG# A040113	
PCB Backstop	49
DWG# A040105	
PCB Backstop – PCC Block	50
DWG# A040117	
Asphalt with PCB Backstop	51
DWG# S040112	
Compact Backstop	52
DWG# A040102	
Flush Mount Backstop – PCC Pad	53
DWG# A040420	
Compact Backstop, PCC Blocks .	54
DWG# A040115	
Asphalt with Compact Backstop .	55
DWG# A040110	
Wide Flange Backstop	56
DWG# A040108	
Foundation Dimension Charts	
English Units	57-59
Metric Units	60-62

FOUNDATION SPECIFICATIONS:

THE TAU-II CRASH CUSHION SYSTEM HAS BEEN DESIGNED TO ATTACH TO CONCRETE OR ASPHALT FOUNDATIONS. USE THE ANCHORAGE SPECIFIED BELOW DEPENDING ON THE FOUNDATION AT THE JOB SITE. REFERENCE UNIVERSAL TAU-II FOUNDATION DRAWINGS FOR FURTHER DETAIL.

1.) CONCRETE PAD

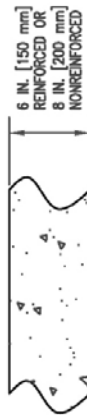

FOUNDATION: MINIMUM 6 IN. [150 mm] REINFORCED PCC PAD OR 8 IN. [200 mm] NONREINFORCED PCC PAD
 ANCHORAGE: 3/4 IN. [20 mm] X 8 1/4 IN. [210 mm] GALVANIZED ANCHOR WITH 6 IN. [150 mm] EMBEDMENT

2.) ASPHALT OVER SUBBASE

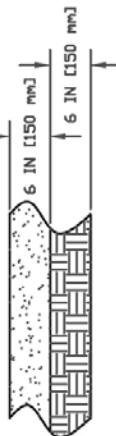

FOUNDATION: MINIMUM 6 IN. [150 mm] AC OVER 6 IN. [150 mm] COMPACTED DGA SUBBASE
 ANCHORAGE: 3/4 IN. [20 mm] X 18 IN. [460 mm] GALVANIZED ANCHORS WITH 16 IN. [410 mm] EMBEDMENT
 ASPHALT ANCHORING KIT REQUIRED

3.) ASPHALT ONLY



FOUNDATION: MINIMUM 8 IN. [200 mm] AC
 ANCHORAGE: 3/4 IN. [20 mm] X 18 IN. [460 mm] GALVANIZED ANCHORS WITH 16 IN. [410 mm] EMBEDMENT
 ASPHALT ANCHORING KIT REQUIRED

4.) ASPHALT OVER P.C. CONCRETE

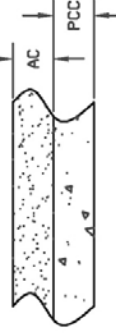

FOUNDATION: AC OVER PCC.
 ANCHORAGE: 3/4 IN. [20 mm] GALVANIZED ANCHORS WITH MINIMUM 6 IN. [150 mm] EMBEDMENT IN PCC - ASPHALT ANCHORING KIT NOT REQUIRED
 OR
 IF 6 IN. [150 mm] EMBEDMENT IN PCC IS NOT POSSIBLE USE
 3/4 IN. [20 mm] X 18 IN. [460 mm] GALVANIZED ANCHORS WITH 16 IN. [410 mm] EMBEDMENT - ASPHALT ANCHORING KIT REQUIRED

MATERIAL SPECIFICATIONS

PORTLAND CEMENT CONCRETE (PCC)

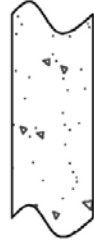

STONE AGGREGATE CONCRETE MIX, 4,000 PSI [28 MPa] MINIMUM COMPRESSIVE STRENGTH (SAMPLING PER ASTM C31-84 OR ASTM C42-94A, TESTING PER ASTM C39-84)

ASPHALTIC CONCRETE (AC)



AR-4000 A.C. (PER ASTM D3381 '89) 75" MAXIMUM, MEDIUM (TYPE A OR B) AGGREGATE

SIEVE SIZE	% PASSING
1"	100
3/4"	95-100
3/8"	65-80
No. 4	49-54
No. 8	36-40
No. 30	18-21
No. 200	3-8

COMPACTED SUBBASE (DGA)



6 IN. [150 mm] MINIMUM DEPTH, 95% COMPACTION, CLASS 2 AGGREGATE

SIEVE SIZE	% PASSING
3"	100
2 1/2"	90-100
No. 4	40-90
No. 200	0-25

SCALE: FULL		DATE		INT.	Standard Tolerance	MODEL		DRAWING NUMBER		REV.	
DRAWN BY		01/09/04		GAD	Angular ± 1/2"	A040113		A040113		A	
APPR'D BY				JSM	Fractional ± 1/16	FOUNDATION SPECIFICATIONS					
DATE		03/02/04		GAD	Dec .XXX= ± .010						
BY		GAD			Dec .XX= ± .030						
REV.		SEE ECN 00589									
CHANGES											
REQ'D		NEXT ASST.		ITEM							

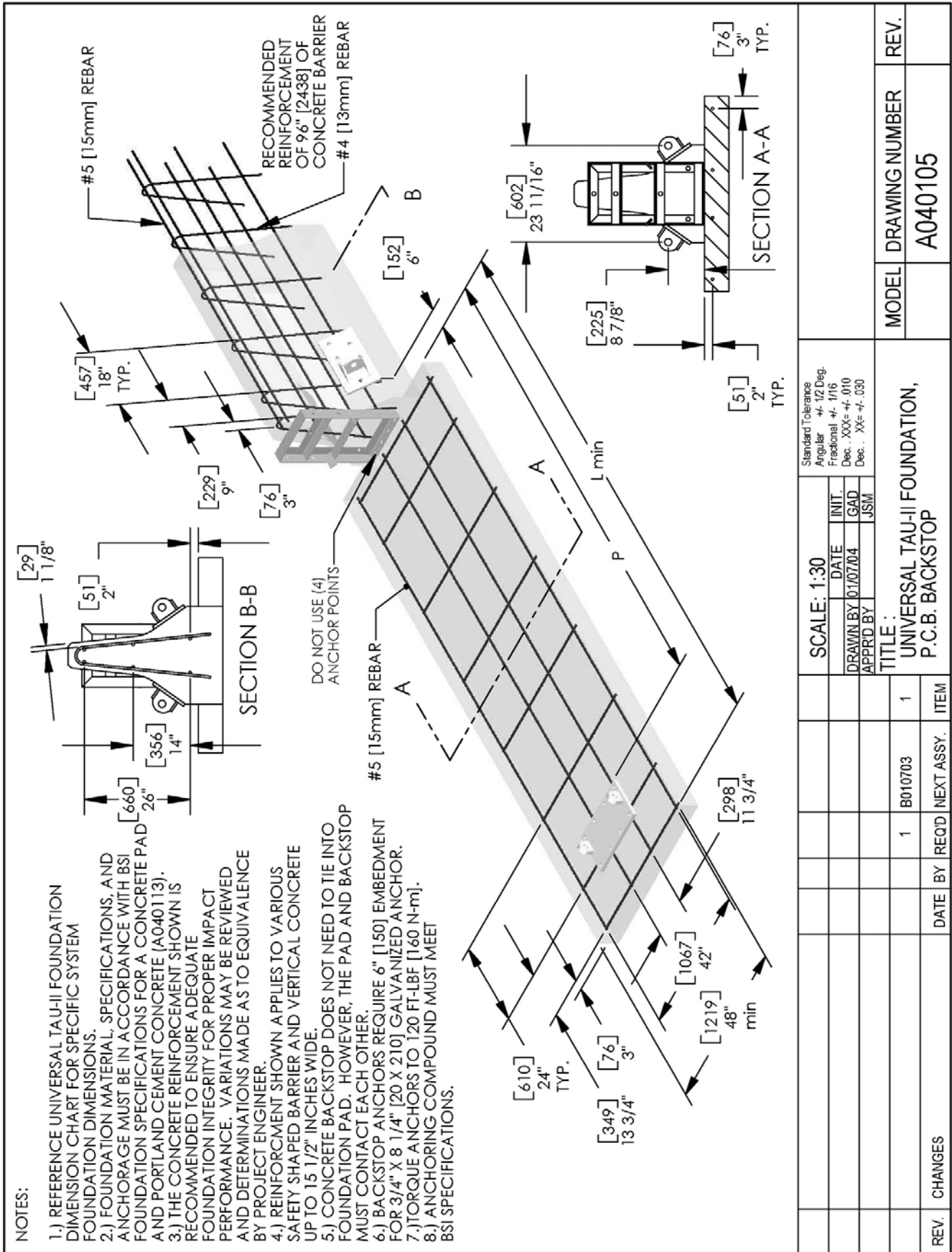

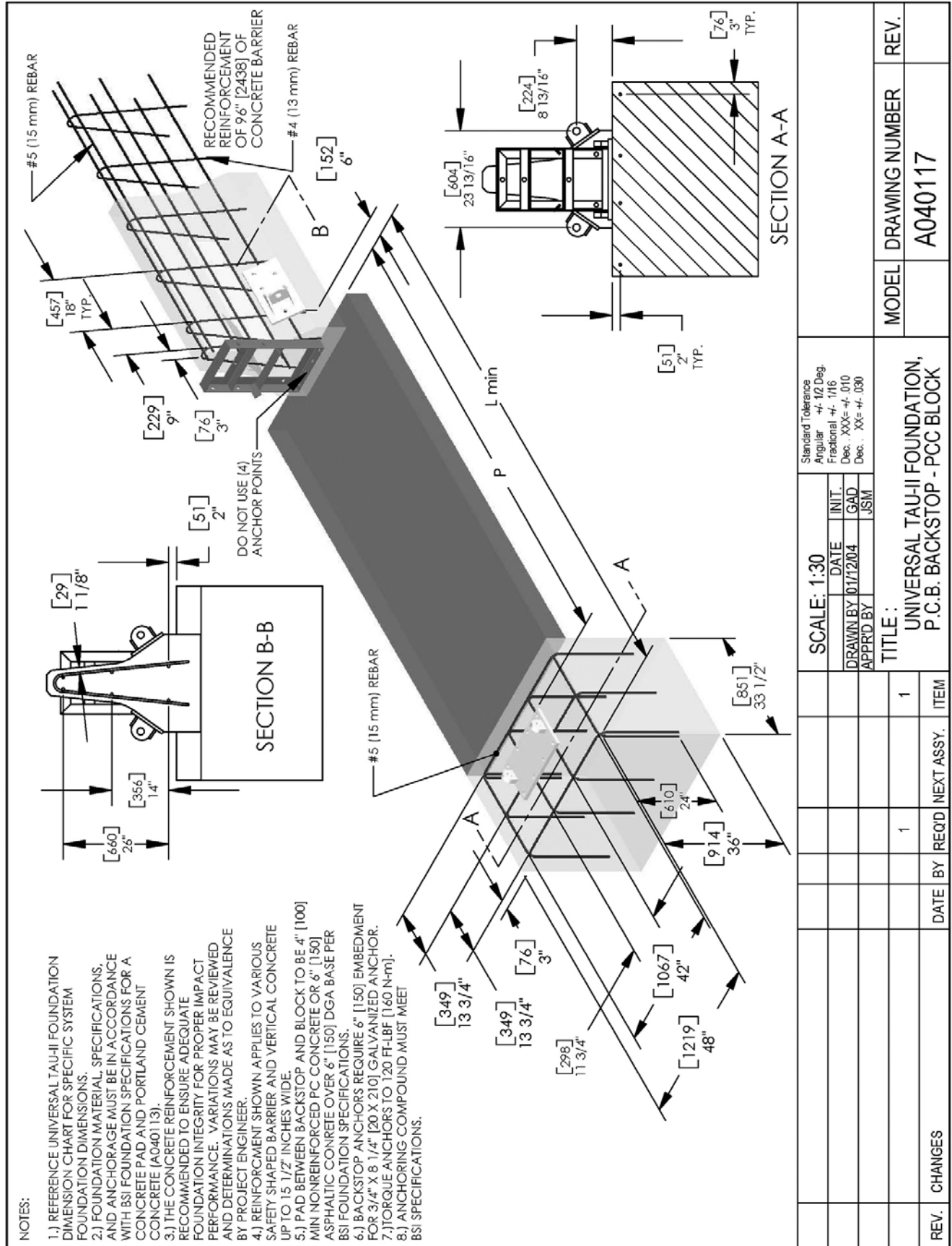

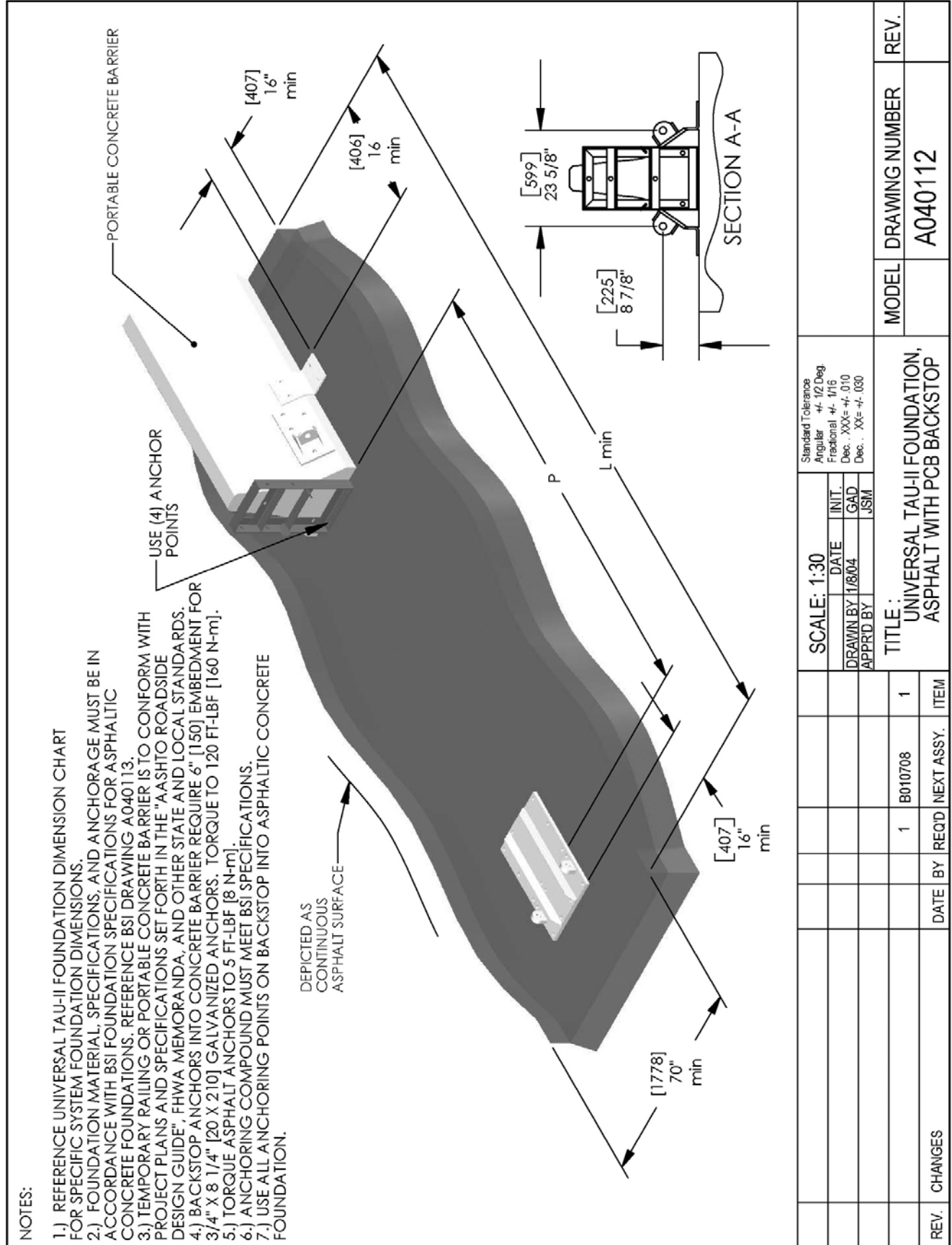

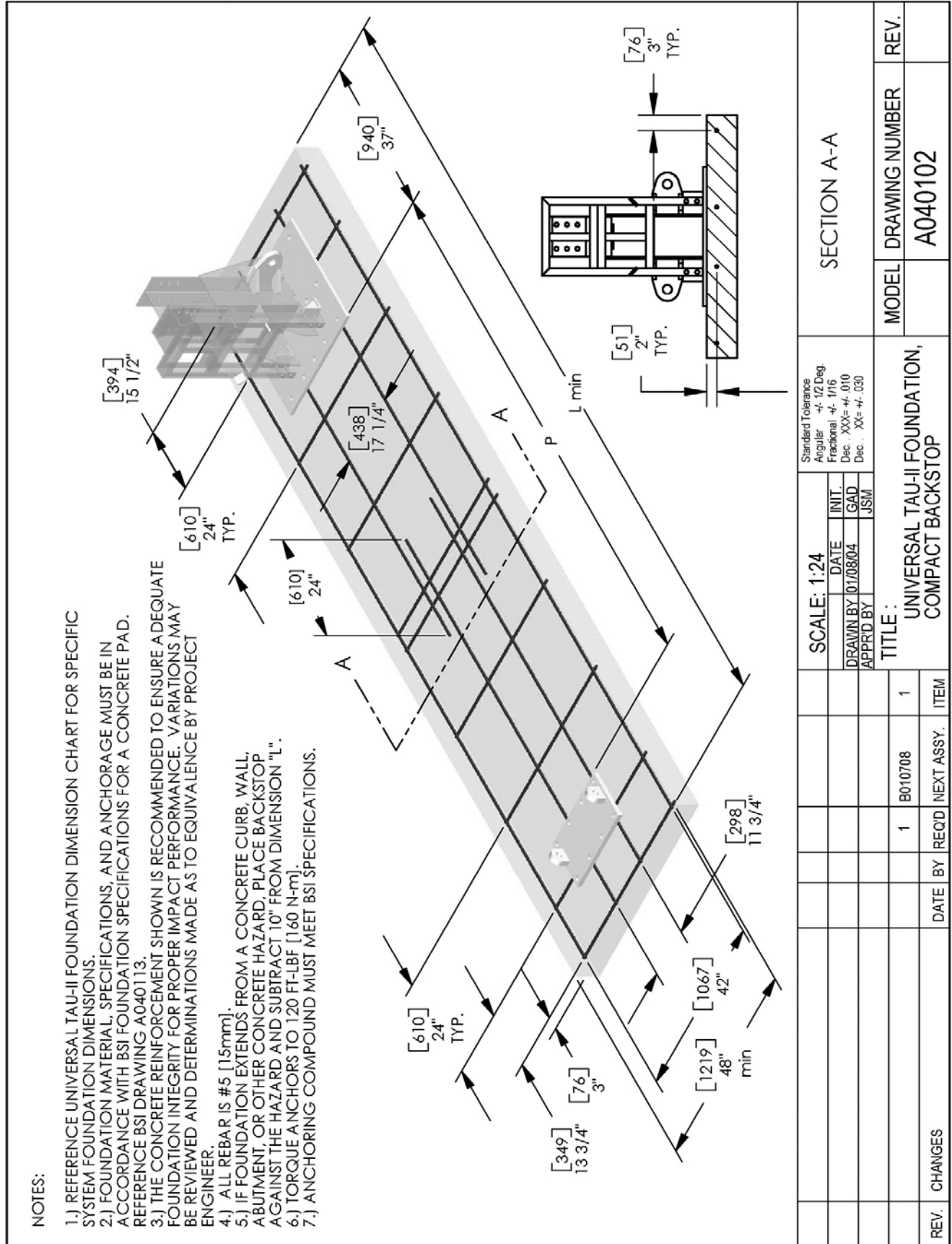

NOTES:

- 1.) REFERENCE UNIVERSAL TAU-II FOUNDATION DIMENSION CHART FOR SPECIFIC SYSTEM FOUNDATION DIMENSIONS.
- 2.) FOUNDATION MATERIAL, SPECIFICATIONS, AND ANCHORAGE MUST BE IN ACCORDANCE WITH BSI FOUNDATION SPECIFICATIONS FOR A CONCRETE PAD AND PORTLAND CEMENT CONCRETE. REFERENCE BSI SPECIFICATION A040113.
- 3.) REINFORCEMENT OF CONCRETE PAD AND BACKSTOP TO EQUAL REINFORCEMENT SPECIFIED IN BSI A040105. THE REINFORCEMENT IS RECOMMENDED TO ENSURE ADEQUATE FOUNDATION INTEGRITY FOR PROPER IMPACT PERFORMANCE. VARIATIONS MAY BE REVIEWED AND DETERMINATIONS MADE AS TO EQUIVALENCE BY PROJECT ENGINEER.

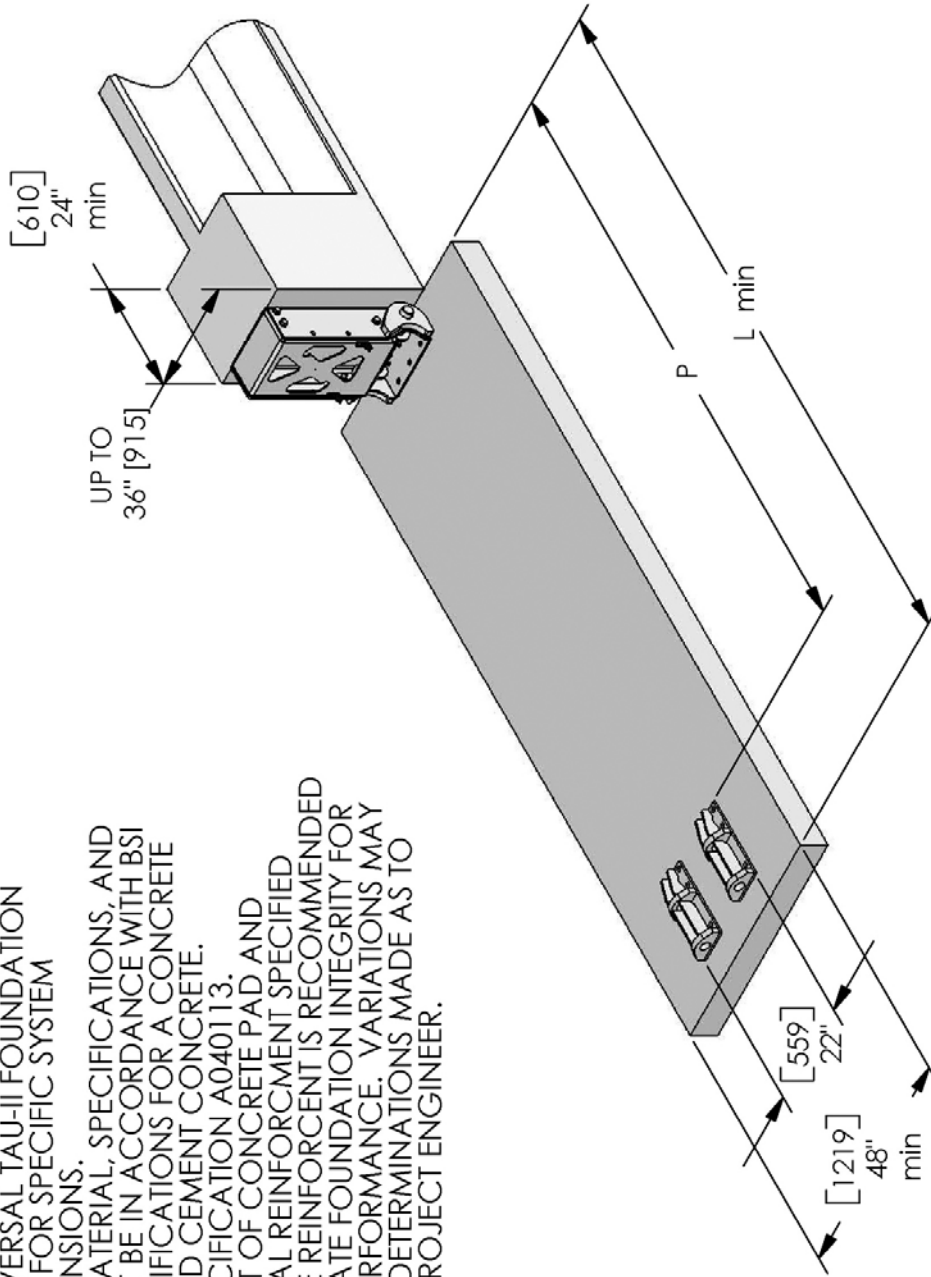

SCALE: 1:30		DATE INIT.		Standard Tolerance		
DRAWN BY	04/28/04	GAD	OSD	Angular	+/- .12 Deg	
APPRD BY				Fractional	+/- 1/16	
TITLE: UNIVERSAL TAU-II FOUNDATION, FLUSH MOUNT BACKSTOP - PCC PAD				Dec.	XXX= +/- .010	
				Dec.	XX= +/- .030	
REV.	CHANGES	DATE	BY	REQD.	NEXT ASSY.	ITEM
				1	B040239	1
MODEL	DRAWING NUMBER	REV.				
	A040420					

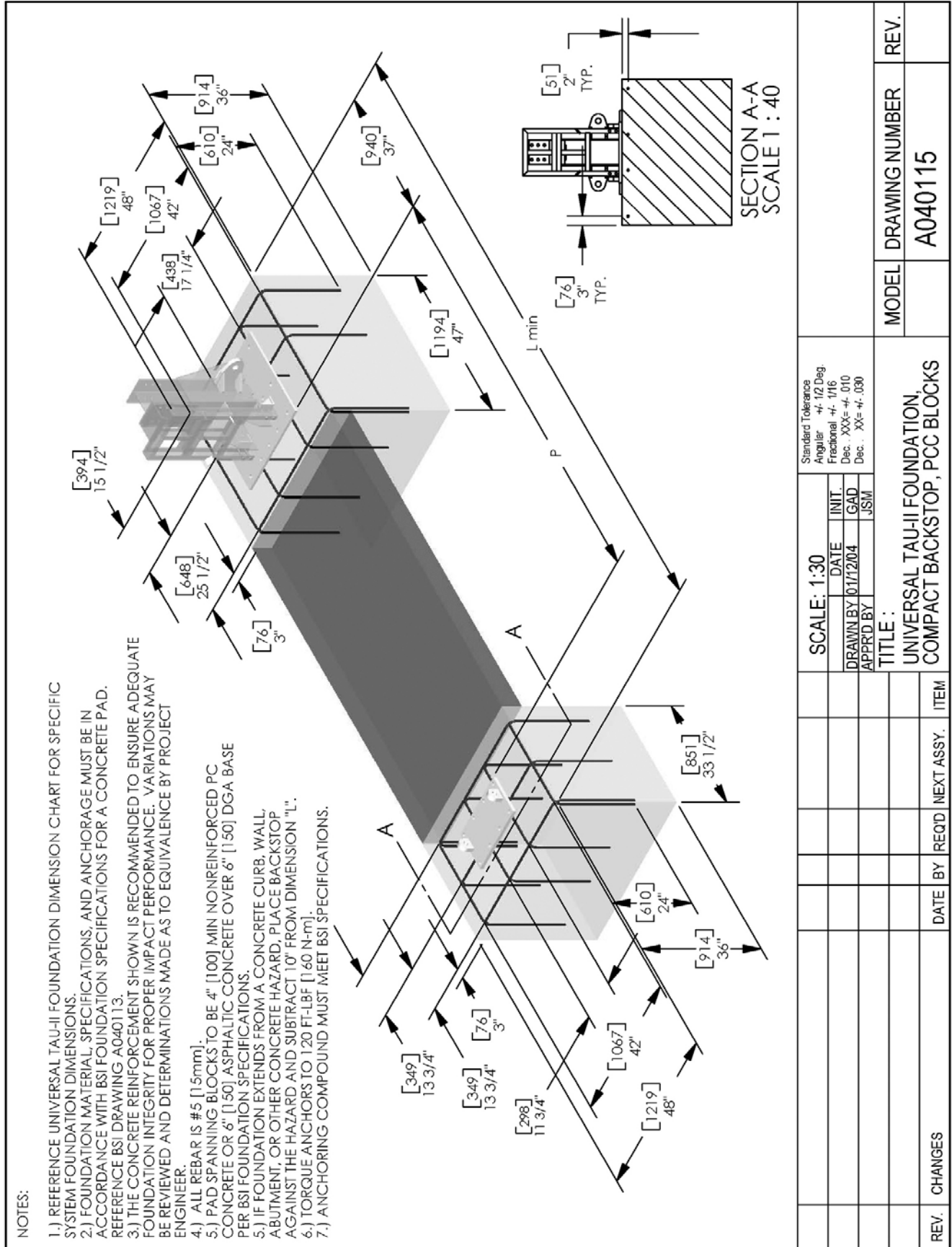

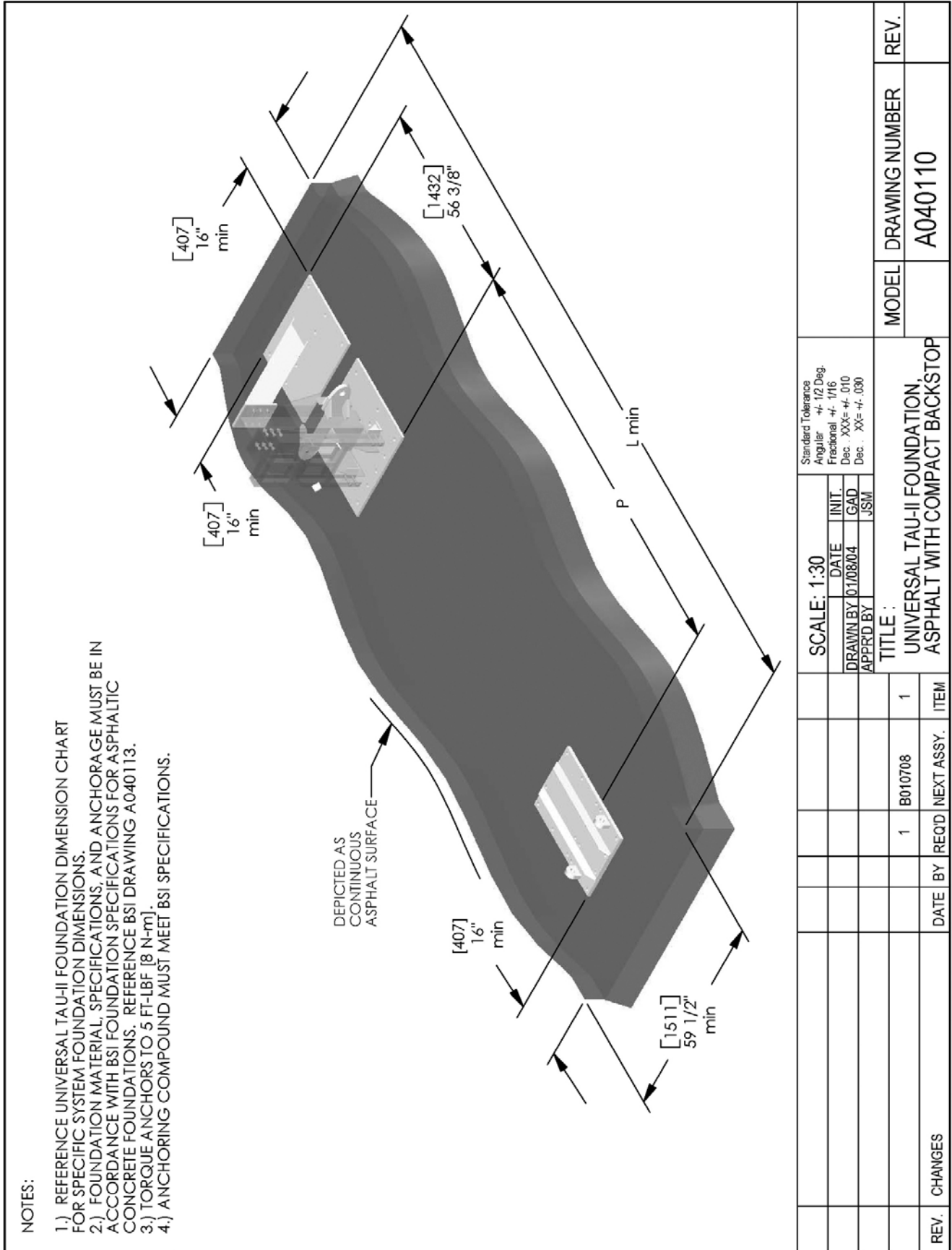

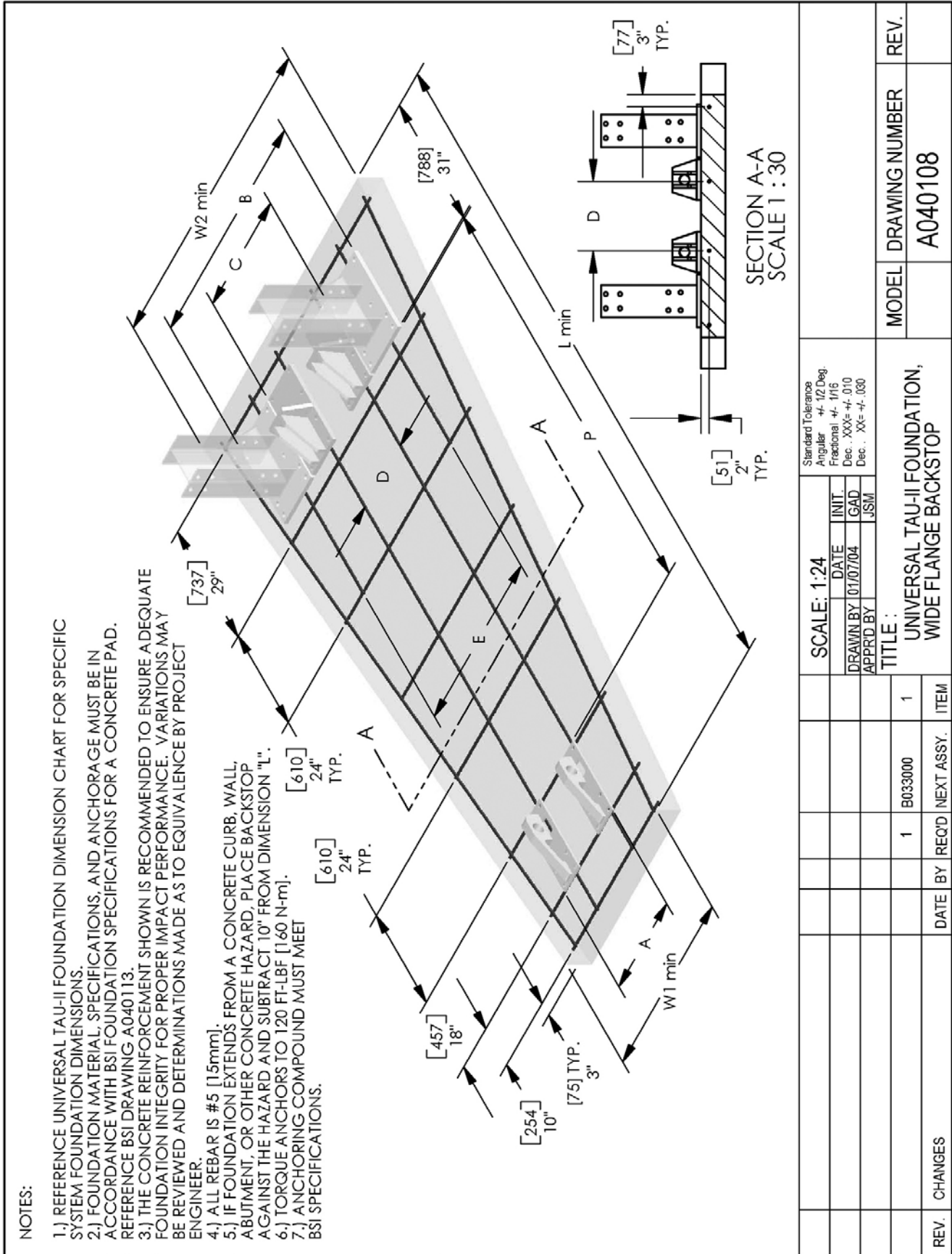

UNIVERSAL TAU-II FOUNDATION DIMENSIONS													DRAWING NUMBER	
US STANDARD UNITS - INCHES														
SYSTEM WIDTH (IN)	SYSTEM SPEED CAPACITY (MPH)													
	30	35	40 TL-2	50	53	55	60 TL-3	65	70	72	75			
UP TO 30" PCB BACKSTOP	30T050PBC 85 1/2 62 3/4	30T060PBC 119 1/2 96 7/8	30T070PBC 154 131	30T080PBC 188 165 1/8	30T085PBC 222 199 1/4	30T090PBC 256 233 3/8	30T100PBC 290 1/2 267 1/2	30T105PBC 324 1/2 301 1/2	30T110PBC 358 1/2 335 3/4	30T115PBC 392 1/2 369 7/8	30T120PBC 426 1/2 404		A040105 A040117	
UP TO 30" COMPACT BACKSTOP	30T050CBC 85 1/2 62 3/4	30T060CBC 119 1/2 96 7/8	30T070CBC 154 131	30T080CBC 188 165 1/8	30T085CBC 222 199 1/4	30T090CBC 256 233 3/8	30T100CBC 290 1/2 267 1/2	30T105CBC 324 1/2 301 1/2	30T110CBC 358 1/2 335 3/4	30T115CBC 392 1/2 369 7/8	30T120CBC 426 1/2 404		A040102 A040115	
UP TO 30" ASPHALT PCB BACKSTOP	30T050PYA 139 3/4 62 3/4	30T060PYA 173 3/4 96 7/8	30T070PYA 208 1/4 131	30T080PYA 242 1/4 165 7/8	30T085PYA 276 1/4 199 1/4	30T090PYA 310 1/4 233 3/8	30T100PYA 344 3/4 267 1/2	30T105PYA 378 3/4 301 1/2	30T110PYA 412 3/4 335 3/4	30T115PYA 446 3/4 369 7/8	30T120PYA 480 3/4 404		A040112	
UP TO 30" ASPHALT COMPACT BACKSTOP	30T050CYA 156 1/2 55 1/2	30T060CYA 190 1/2 89 5/8	30T070CYA 224 1/2 123 3/4	30T080CYA 258 1/2 157 7/8	30T085CYA 293 192	30T090CYA 327 226 1/8	30T100CYA 361 260 1/4	30T105CYA 394 294 1/4	30T110CYA 429 1/2 328 1/2	30T115CYA 463 1/2 362 5/8	30T120CYA 497 1/2 396 3/4		A040110	
36" PCB BACKSTOP	36T050PBC 85 1/2 62 3/4	36T060PBC 119 1/2 96 7/8	36T070PBC 154 131	36T080PBC 188 165 1/8	36T085PBC 222 199 1/4	36T090PBC 256 233 3/8	36T100PBC 290 1/2 267 1/2	36T105PBC 324 1/2 301 1/5	36T110PBC 358 1/2 335 3/4	36T115PBC 392 1/2 369 7/8	36T120PBC 426 1/2 404		A040105 A040117	
36" COMPACT BACKSTOP	36T050CBC 85 1/2 62 3/4	36T060CBC 119 1/2 96 7/8	36T070CBC 154 131	36T080CBC 188 165 1/8	36T085CBC 222 199 1/4	36T090CBC 256 233 3/8	36T100CBC 290 1/2 267 1/2	36T105CBC 324 1/2 301 1/5	36T110CBC 358 1/2 335 3/4	36T115CBC 392 1/2 369 7/8	36T120CBC 426 1/2 404		A040102 A040115	
36" ASPHALT PCB BACKSTOP	36T050PYA 139 3/4 62 3/4	36T060PYA 173 3/4 96 7/8	36T070PYA 208 1/4 131	36T080PYA 242 1/4 165 7/8	36T085PYA 276 1/4 199 1/4	36T090PYA 310 1/4 233 3/8	36T100PYA 344 3/4 267 1/2	36T105PYA 378 3/4 301 1/4	36T110PYA 412 3/4 335 3/4	36T115PYA 446 3/4 369 7/8	36T120PYA 480 3/4 404		A040112	
36" ASPHALT COMPACT BACKSTOP	36T050CYA 156 1/2 55 1/2	36T060CYA 190 1/2 89 5/8	36T070CYA 224 1/2 123 3/4	36T080CYA 258 1/2 157 7/8	36T085CYA 293 192	36T090CYA 327 226 1/8	36T100CYA 361 260 1/4	36T105CYA 394 294 1/4	36T110CYA 429 1/2 328 1/2	36T115CYA 463 1/2 362 5/8	36T120CYA 497 1/2 396 3/4		A040110	
UP TO 36" PCC PAD FLUSH MOUNT BACKSTOP	42T050WBC 125 W1 (in) W2 (in) P (in) A (in) B (in) C (in)* D (in) E (in)*	42T060WBC 159 44 51 99 22 31 NA 16	42T070WBC 193 44 51 133 22 31 NA 16	42T080WBC 227 44 51 167 22 31 NA 16	42T085WBC 220 196	42T090WBC 254 230	42T100WBC 288 264	42T105WBC 322 298	42T105WBC 397 44 51 303 22 31 NA 16	42T110WBC 356 1/2 332 1/2	42T110WBC 390 1/2 366 1/2	42T120WBC 424 1/2 400 1/2		A040420

SYSTEM WIDTH (IN)	SYSTEM SPEED CAPACITY (MPH)										DRAWING NUMBER	
	30	35	40 TL-2	50	53	55	60 TL-3	65	70	72		75
48" WF BACKSTOP	48T050WBC	48T060WBC	48T070WBC	48T080WBC		48T090WBC	48T100WBC	48T105WBC	48T110WBC			A040108
	48T050WYC	48T060WYC	48T070WYC	48T080WYC		48T090WYC	48T100WYC	48T105WYC	48T110WYC			
	125	159	193	227		295	329	363	397			
	44	44	44	44		44	44	44	44			
	W1 (in)	51	51	51		51	51	51	51			
	W2 (in)	65	99	133	167		269	269	303	337		
	P (in)	22	22	22	22		22	22	22	22		
	A (in)	31	31	31	31		31	31	31	31		
	B (in)	NA	NA	NA	NA		NA	NA	NA	NA		
	C (in)*	16	16	16	16		16	16	16	16		
D (in)*	NA	NA	NA	NA		NA	NA	NA	NA			
E (in)*	NA	NA	NA	NA		NA	NA	NA	NA			
54" WF BACKSTOP	54T050WBC	54T060WBC	54T070WBC	54T080WBC		54T090WBC	54T100WBC	54T105WBC	54T110WBC			A040108
	54T050WYC	54T060WYC	54T070WYC	54T080WYC		54T090WYC	54T100WYC	54T105WYC	54T110WYC			
	125	159	193	227		295	329	363	397			
	44	44	44	44		44	44	44	44			
	W1 (in)	51	51	51		51	51	51	51			
	W2 (in)	65	99	133	167		269	269	303	337		
	P (in)	22	22	22	22		22	22	22	22		
	A (in)	31	31	31	31		31	31	31	31		
	B (in)	NA	NA	NA	NA		NA	NA	NA	NA		
	C (in)*	16	16	16	16		16	16	16	16		
D (in)*	NA	NA	NA	NA		NA	NA	NA	NA			
E (in)*	NA	NA	NA	NA		NA	NA	NA	NA			
60" WF BACKSTOP	60T050WBC	60T060WBC	60T070WBC	60T080WBC		60T090WBC	60T100WBC	60T105WBC	60T110WBC			A040108
	60T050WYC	60T060WYC	60T070WYC	60T080WYC		60T090WYC	60T100WYC	60T105WYC	60T110WYC			
	125	159	193	227		295	329	363	397			
	44	44	44	44		44	44	44	44			
	W1 (in)	51	51	51		51	51	51	51			
	W2 (in)	65	99	133	167		269	269	303	337		
	P (in)	22	22	22	22		22	22	22	22		
	A (in)	31	31	31	31		31	31	31	31		
	B (in)	NA	NA	NA	NA		NA	NA	NA	NA		
	C (in)*	16	16	16	16		16	16	16	16		
D (in)*	NA	NA	NA	NA		NA	NA	NA	NA			
E (in)*	NA	NA	NA	NA		NA	NA	NA	NA			
66" WF BACKSTOP	66T060WBC	66T060WYC	66T070WBC	66T080WBC		66T090WBC	66T100WBC	66T105WBC	66T110WBC			A040108
	66T060WBC	66T060WYC	66T070WYC	66T080WYC		66T090WYC	66T100WYC	66T105WYC	66T110WYC			
	125	159	193	227		261	295	329	363			
	69	69	69	69		44	44	44	44			
	W1 (in)	75	75	75		75	75	75	75			
	W2 (in)	99	133	167	201		235	269	303	337		
	P (in)	22	22	22	22		22	22	22	22		
	A (in)	48 5/8	54 3/4	54 3/4	54 3/4		54 3/4	54 3/4	54 3/4	54 3/4		
	B (in)	NA	NA	NA	NA		NA	NA	NA	NA		
	C (in)*	42 5/8	42 5/8	42 5/8	42 5/8		42 5/8	42 5/8	42 5/8	42 5/8		
D (in)*	NA	NA	NA	NA		NA	NA	NA	NA			
E (in)*	NA	NA	NA	NA		NA	NA	NA	NA			
72" WF BACKSTOP	72T060WBC	72T060WYC	72T070WBC	72T080WBC		72T090WBC	72T100WBC	72T105WBC	72T110WBC			A040108
	72T060WBC	72T060WYC	72T070WYC	72T080WYC		72T090WYC	72T100WYC	72T105WYC	72T110WYC			
	125	159	193	227		227	295	329	363			
	69	69	69	69		44	44	44	44			
	W1 (in)	75	75	75		75	75	75	75			
	W2 (in)	99	133	167	201		235	269	303	337		
	P (in)	22	22	22	22		22	22	22	22		
	A (in)	48 5/8	54 3/4	54 3/4	54 3/4		54 3/4	54 3/4	54 3/4	54 3/4		
	B (in)	NA	NA	NA	NA		NA	NA	NA	NA		
	C (in)*	42 5/8	42 5/8	42 5/8	42 5/8		42 5/8	42 5/8	42 5/8	42 5/8		
D (in)*	NA	NA	NA	NA		NA	NA	NA	NA			
E (in)*	NA	NA	NA	NA		NA	NA	NA	NA			

SYSTEM WIDTH (IN)	SYSTEM SPEED CAPACITY (MPH)										DRAWING NUMBER
	30	35	40 TL-2	50	53	55	60 TL-3	65	70	72	
78" WF BACKSTOP	78T060WBC	78T060WYC	78T070WBC	78T080WBC	78T080WYC	78T090WBC	78T100WBC	78T105WBC	78T110WBC		
	125	193	159	193	227	227	295	329	329		
	69	69	69	69	44	44	44	44	44		
	75	75	75	75	75	75	75	75	75		
	65	133	99	133	167	167	235	269	269		
	A (in)	48 5/8	48 5/8	48 5/8	48 5/8	48 5/8	54 3/4	54 3/4	54 3/4		
	B (in)	54 3/4	54 3/4	54 3/4	54 3/4	54 3/4	27 3/4	27 3/4	27 3/4		
	C (in) *	NA	NA	NA	NA	NA	16	16	16		
	D (in) *	42 5/8	42 5/8	42 5/8	42 5/8	42 5/8	41 3/4	41 3/4	41 3/4		
	E (in) *	NA	NA	NA	NA	NA	41 3/4	41 3/4	41 3/4		
84" WF BACKSTOP	84T070WBC	84T080WBC	84T070WYC	84T080WBC	84T090WBC	84T090WYC	84T100WBC	84T105WBC	84T110WBC		
	159	193	159	193	227	227	295	329	329		
	69	69	69	69	69	69	44	44	44		
	75	75	75	75	75	75	75	75	75		
	P (in)	133	99	133	167	167	235	269	269		
	A (in)	48 5/8	48 5/8	48 5/8	48 5/8	48 5/8	54 3/4	54 3/4	54 3/4		
	B (in)	54 3/4	54 3/4	54 3/4	54 3/4	54 3/4	27 3/4	27 3/4	27 3/4		
	C (in) *	NA	NA	NA	NA	NA	16	16	16		
	D (in) *	42 5/8	42 5/8	42 5/8	42 5/8	42 5/8	41 3/4	41 3/4	41 3/4		
	E (in) *	NA	NA	NA	NA	NA	41 3/4	41 3/4	41 3/4		
90" WF BACKSTOP	90T070WBC	90T080WBC	90T070WYC	90T080WBC	90T090WBC	90T090WYC	90T100WBC	90T105WBC	90T110WBC		
	159	193	159	193	227	227	295	329	329		
	69	69	69	69	69	69	44	44	44		
	75	75	75	75	75	75	75	75	75		
	P (in)	133	99	133	167	167	235	269	269		
	A (in)	48 5/8	48 5/8	48 5/8	48 5/8	48 5/8	54 3/4	54 3/4	54 3/4		
	B (in)	78 5/8	78 5/8	78 5/8	78 5/8	78 5/8	27 3/4	27 3/4	27 3/4		
	C (in) *	51 5/8	51 5/8	51 5/8	51 5/8	51 5/8	16	16	16		
	D (in) *	42 5/8	42 5/8	42 5/8	42 5/8	42 5/8	65 5/8	65 5/8	65 5/8		
	E (in) *	65 5/8	65 5/8	65 5/8	65 5/8	65 5/8	65 5/8	65 5/8	65 5/8		
96" WF BACKSTOP	96T070WBC	96T080WBC	96T070WYC	96T080WBC	96T090WBC	96T090WYC	96T100WBC	96T105WBC	96T110WBC		
	159	193	159	193	227	227	295	329	329		
	93	69	93	69	69	69	69	69	69		
	99	99	99	99	99	99	99	99	99		
	P (in)	133	99	133	167	167	235	269	269		
	A (in)	48 5/8	48 5/8	48 5/8	48 5/8	48 5/8	48 5/8	48 5/8	48 5/8		
	B (in)	78 5/8	78 5/8	78 5/8	78 5/8	78 5/8	78 5/8	78 5/8	78 5/8		
	C (in) *	51 5/8	51 5/8	51 5/8	51 5/8	51 5/8	51 5/8	51 5/8	51 5/8		
	D (in) *	42 5/8	42 5/8	42 5/8	42 5/8	42 5/8	42 5/8	42 5/8	42 5/8		
	E (in) *	NA	65 5/8	NA	65 5/8	65 5/8	65 5/8	65 5/8	65 5/8		
102" WF BACKSTOP	102T110WBC	102T110WYC									
	329	329									
	69	69									
	99	99									
	P (in)	269									
	A (in)	48 5/8									
	B (in)	78 5/8									
	C (in) *	51 5/8									
	D (in) *	42 5/8									
	E (in) *	65 5/8									

UNIVERSAL TAU-II FOUNDATION DIMENSIONS

METRIC UNITS - MILLIMETERS

SYSTEM WIDTH (mm)	SYSTEM SPEED CAPACITY (KPH)												DRAWING NUMBER
	50	60	70 TL-2	80	85	90	100 TL-3	105	110	115	120		
UP TO 760mm PCB BACKSTOP	30T050PBC	30T060PBC	30T070PBC	30T080PBC	30T085PBC	30T090PBC	30T100PBC	30T105PBC	30T110PBC	30T115PBC	30T120PBC	A040105	
	30T050PYC	30T060PYC	30T070PYC	30T080PYC	30T085PYC	30T090PYC	30T100PYC	30T105PYC	30T110PYC	30T115PYC	30T120PYC	A040117	
	L (mm) P (mm)	3035 2461	3912 3327	4775 4194	5639 5061	6502 5828	7379 6795	8242 7661	9106 8528	9970 9395	10833 10262		
UP TO 760mm ASPHALT PCB BACKSTOP	30T050CBC	30T060CBC	30T070CBC	30T080CBC	30T085CBC	30T090CBC	30T100CBC	30T105CBC	30T110CBC	30T115CBC	30T120CBC	A040102	
	30T050CYC	30T060CYC	30T070CYC	30T080CYC	30T085CYC	30T090CYC	30T100CYC	30T105CYC	30T110CYC	30T115CYC	30T120CYC	A040115	
	L (mm) P (mm)	2934 2276	4661 3143	5525 4010	6401 4877	7264 5744	8128 6610	8991 7477	9868 8344	10732 9211	11595 10077		
UP TO 760mm ASPHALT PCB BACKSTOP	30T050PBA	30T060PBA	30T070PBA	30T080PBA	30T085PBA	30T090PBA	30T100PBA	30T105PBA	30T110PBA	30T115PBA	30T120PBA	A040112	
	30T050PYA	30T060PYA	30T070PYA	30T080PYA	30T085PYA	30T090PYA	30T100PYA	30T105PYA	30T110PYA	30T115PYA	30T120PYA		
	L (mm) P (mm)	4413 2461	5290 3327	6153 4194	7017 5061	7880 5928	8757 6795	9620 7661	10484 8528	11347 9395	12211 10262		
UP TO 760mm ASPHALT COMPACT BACKSTOP	30T050CBA	30T060CBA	30T070CBA	30T080CBA	30T085CBA	30T090CBA	30T100CBA	30T105CBA	30T110CBA	30T115CBA	30T120CBA	A040110	
	30T050CYA	30T060CYA	30T070CYA	30T080CYA	30T085CYA	30T090CYA	30T100CYA	30T105CYA	30T110CYA	30T115CYA	30T120CYA		
	L (mm) P (mm)	3975 1410	5702 3143	6566 4010	7442 4877	8306 5744	9169 6610	10033 8344	10909 9211	11773 9970	12637 10833		
915mm PCB BACKSTOP	36T050PBC	36T060PBC	36T070PBC	36T080PBC	36T085PBC	36T090PBC	36T100PBC	36T105PBC	36T110PBC	36T115PBC	36T120PBC	A040105	
	36T050PYC	36T060PYC	36T070PYC	36T080PYC	36T085PYC	36T090PYC	36T100PYC	36T105PYC	36T110PYC	36T115PYC	36T120PYC	A040117	
	L (mm) P (mm)	3035 2461	3912 3327	4775 4194	5639 5061	6502 5828	7379 6795	8242 7661	9106 8528	9970 9395	10833 10262		
915mm COMPACT BACKSTOP	36T050CBC	36T060CBC	36T070CBC	36T080CBC	36T085CBC	36T090CBC	36T100CBC	36T105CBC	36T110CBC	36T115CBC	36T120CBC	A040102	
	36T050CYC	36T060CYC	36T070CYC	36T080CYC	36T085CYC	36T090CYC	36T100CYC	36T105CYC	36T110CYC	36T115CYC	36T120CYC	A040115	
	L (mm) P (mm)	2934 2276	4661 3143	5525 4010	6401 4877	7264 5744	8128 6610	8991 7477	9868 8344	10732 9211	11595 10077		
915mm ASPHALT PCB BACKSTOP	36T050PBA	36T060PBA	36T070PBA	36T080PBA	36T085PBA	36T090PBA	36T100PBA	36T105PBA	36T110PBA	36T115PBA	36T120PBA	A040112	
	36T050PYA	36T060PYA	36T070PYA	36T080PYA	36T085PYA	36T090PYA	36T100PYA	36T105PYA	36T110PYA	36T115PYA	36T120PYA		
	L (mm) P (mm)	4413 2461	5290 3327	6153 4194	7017 5061	7880 5928	8757 6795	9620 7661	10484 8528	11347 9395	12211 10262		
915mm ASPHALT COMPACT BACKSTOP	36T050CBA	36T060CBA	36T070CBA	36T080CBA	36T085CBA	36T090CBA	36T100CBA	36T105CBA	36T110CBA	36T115CBA	36T120CBA	A040110	
	36T050CYA	36T060CYA	36T070CYA	36T080CYA	36T085CYA	36T090CYA	36T100CYA	36T105CYA	36T110CYA	36T115CYA	36T120CYA		
	L (mm) P (mm)	3975 1410	5702 3143	6566 4010	7442 4877	8306 5744	9169 6610	10033 8344	10909 9211	11773 9970	12637 10833		
UP TO 915mm PCC PAD FLUSH MOUNT BACKSTOP	42T050PBC	42T060PBC	42T070PBC	42T080PBC	42T085PBC	42T090PBC	42T100PBC	42T105PBC	42T110PBC	42T115PBC	42T120PBC	A040420	
	42T050PYC	42T060PYC	42T070PYC	42T080PYC	42T085PYC	42T090PYC	42T100PYC	42T105PYC	42T110PYC	42T115PYC	42T120PYC		
	L (mm) P (mm)	2121 1511	3848 3239	4712 4102	5588 4978	6452 5842	7315 6706	8179 7569	9055 8446	9919 9309	10782 10173		
1076mm WF BACKSTOP	42T050WBC	42T060WBC	42T070WBC	42T080WBC	42T085WBC	42T090WBC	42T100WBC	42T105WBC	42T110WBC	42T115WBC	42T120WBC	A040108	
	42T050WYC	42T060WYC	42T070WYC	42T080WYC	42T085WYC	42T090WYC	42T100WYC	42T105WYC	42T110WYC	42T115WYC	42T120WYC		
	L (mm) W1 (mm) W2 (mm) A (mm) B (mm) C (mm) D (mm) E (mm)	3175 1118 1295 1651 559 787 NA 406 NA	4039 1118 1295 3378 559 787 NA 406 NA	4902 1118 1295 4242 559 787 NA 406 NA	5766 1118 1295 4242 559 787 NA 406 NA	6630 1118 1295 4242 559 787 NA 406 NA	7493 1118 1295 4242 559 787 NA 406 NA	8357 1118 1295 4242 559 787 NA 406 NA	9220 1118 1295 4242 559 787 NA 406 NA	10084 1118 1295 4242 559 787 NA 406 NA	10948 1118 1295 4242 559 787 NA 406 NA	11811 1295 4242 559 787 NA 406 NA	12674 10833 9211 7661 6100 4549 3000 1450 NA

SYSTEM WIDTH (mm)	SYSTEM SPEED CAPACITY (KPH)												DRAWING NUMBER
	50	60	70 TL-2	80	85	90	100 TL-3	105	110	115	120		
1220mm WF BACKSTOP	48T050WBC	48T060WBC	48T070WBC	48T080WBC	48T090WBC	48T090WBC	48T100WBC	48T105WBC	48T110WBC				A040108
	48T050WYC	48T060WYC	48T070WYC	48T080WYC	48T090WYC	48T090WYC	48T100WYC	48T105WYC	48T110WYC				
	3175	4039	4902	5766	7493	7493	8357	9220	10084				
	1118	1118	1118	1118	1118	1118	1118	1118	1118				
	1295	1295	1295	1295	1295	1295	1295	1295	1295				
	1651	2515	3378	4242	5969	5969	6833	7696	8560				
	559	559	559	559	559	559	559	559	559				
	787	787	787	787	787	787	787	787	787				
	NA	NA	NA	NA	NA	NA	NA	NA	NA				
	406	406	406	406	406	406	406	406	406				
1370mm WF BACKSTOP	54T050WBC	54T060WBC	54T070WBC	54T080WBC	54T090WBC	54T090WBC	54T100WBC	54T105WBC	54T110WBC				A040108
	54T050WYC	54T060WYC	54T070WYC	54T080WYC	54T090WYC	54T090WYC	54T100WYC	54T105WYC	54T110WYC				
	3175	4039	4902	5766	7493	7493	8357	9220	10084				
	1118	1118	1118	1118	1118	1118	1118	1118	1118				
	1295	1295	1295	1295	1295	1295	1295	1295	1295				
	1651	2515	3378	4242	5969	5969	6833	7696	8560				
	559	559	559	559	559	559	559	559	559				
	787	787	787	787	787	787	787	787	787				
	NA	NA	NA	NA	NA	NA	NA	NA	NA				
	406	406	406	406	406	406	406	406	406				
1525mm WF BACKSTOP	60T050WBC	60T060WBC	60T070WBC	60T080WBC	60T090WBC	60T090WBC	60T100WBC	60T105WBC	60T110WBC				A040108
	60T050WYC	60T060WYC	60T070WYC	60T080WYC	60T090WYC	60T090WYC	60T100WYC	60T105WYC	60T110WYC				
	3175	4039	4902	5766	7493	7493	8357	9220	10084				
	1118	1118	1118	1118	1118	1118	1118	1118	1118				
	1295	1295	1295	1295	1295	1295	1295	1295	1295				
	1651	2515	3378	4242	5969	5969	6833	7696	8560				
	559	559	559	559	559	559	559	559	559				
	787	787	787	787	787	787	787	787	787				
	NA	NA	NA	NA	NA	NA	NA	NA	NA				
	406	406	406	406	406	406	406	406	406				
1675mm WF BACKSTOP	66T060WBC	66T070WBC	66T080WBC	66T090WBC	66T100WBC	66T100WBC	66T110WBC	66T110WBC	66T110WBC				A040108
	66T060WYC	66T070WYC	66T080WYC	66T090WYC	66T100WYC	66T100WYC	66T110WYC	66T110WYC	66T110WYC				
	3175	4039	4902	5766	7493	7493	8357	9220	10084				
	1753	1118	1118	1118	1118	1118	1118	1118	1118				
	1905	1905	1905	1905	1905	1905	1905	1905	1905				
	1651	2515	3378	4242	5969	5969	6833	7696	8560				
	1235	1235	1235	1235	1235	1235	1235	1235	1235				
	1391	1391	1391	1391	1391	1391	1391	1391	1391				
	NA	NA	NA	NA	NA	NA	NA	NA	NA				
	1083	1083	1083	1083	1083	1083	1083	1083	1083				
1830mm WF BACKSTOP	72T060WBC	72T070WBC	72T080WBC	72T090WBC	72T100WBC	72T100WBC	72T110WBC	72T110WBC	72T110WBC				A040108
	72T060WYC	72T070WYC	72T080WYC	72T090WYC	72T100WYC	72T100WYC	72T110WYC	72T110WYC	72T110WYC				
	3175	4039	4902	5766	7493	7493	8357	9220	10084				
	1753	1118	1118	1118	1118	1118	1118	1118	1118				
	1905	1905	1905	1905	1905	1905	1905	1905	1905				
	1651	2515	3378	4242	5969	5969	6833	7696	8560				
	1235	1235	1235	1235	1235	1235	1235	1235	1235				
	1391	1391	1391	1391	1391	1391	1391	1391	1391				
	NA	NA	NA	NA	NA	NA	NA	NA	NA				
	1083	1083	1083	1083	1083	1083	1083	1083	1083				

SYSTEM WIDTH (mm)	SYSTEM SPEED CAPACITY (KPH)										DRAWING NUMBER
	50	60	70 TL-2	80	85	90	100 TL-3	105	110	115	
1980mm WF BACKSTOP	78T060WBC	78T060WBC	78T070WBC	78T080WBC	78T080WBC	78T090WBC	78T100WBC	78T105WBC	78T110WBC		
	78T060WYC	78T060WYC	78T070WYC	78T080WYC	78T080WYC	78T090WYC	78T100WYC	78T105WYC	78T110WYC		
	L (mm)	3175	4039	4902	4902	5766	7493	8357	8357		
	W1 (mm)	1753	1753	1753	1753	1753	1118	1118	1118		
	W2 (mm)	1905	1905	1905	1905	1905	1905	1905	1905		
	P (mm)	1651	3378	2515	3378	4242	5969	6833	6833		
	A (mm)	1235	1235	1235	1235	1235	1235	1235	1235		
2135mm WF BACKSTOP	84T070WBC	84T070WBC	84T070WBC	84T080WBC	84T080WBC	84T090WBC	84T100WBC	84T105WBC	84T110WBC		
	84T070WYC	84T070WYC	84T070WYC	84T080WYC	84T080WYC	84T090WYC	84T100WYC	84T105WYC	84T110WYC		
	L (mm)	4039	4039	4902	4902	5766	7493	8357	8357		
	W1 (mm)	1753	1753	1753	1753	1753	1118	1118	1118		
	W2 (mm)	1905	1905	1905	1905	1905	1905	1905	1905		
	P (mm)	2515	3378	2515	3378	4242	5969	6833	6833		
	A (mm)	1235	1235	1235	1235	1235	1235	1235	1235		
2285mm WF BACKSTOP	90T070WBC	90T070WBC	90T070WBC	90T080WBC	90T080WBC	90T090WBC	90T100WBC	90T105WBC	90T110WBC		
	90T070WYC	90T070WYC	90T070WYC	90T080WYC	90T080WYC	90T090WYC	90T100WYC	90T105WYC	90T110WYC		
	L (mm)	4039	4039	4902	4902	5766	7493	8357	8357		
	W1 (mm)	1753	1753	1753	1753	1753	1118	1118	1118		
	W2 (mm)	2515	2515	2515	2515	2515	2515	2515	2515		
	P (mm)	3378	3378	3378	3378	4242	5969	6833	6833		
	A (mm)	1235	1235	1235	1235	1235	1235	1235	1235		
2440mm WF BACKSTOP	96T070WBC	96T070WBC	96T070WBC	96T080WBC	96T080WBC	96T090WBC	96T100WBC	96T105WBC	96T110WBC		
	96T070WYC	96T070WYC	96T070WYC	96T080WYC	96T080WYC	96T090WYC	96T100WYC	96T105WYC	96T110WYC		
	L (mm)	4039	4039	4902	4902	5766	7493	8357	8357		
	W1 (mm)	2362	1753	1753	1753	1753	1753	1118	1118		
	W2 (mm)	2515	2515	2515	2515	2515	2515	2515	2515		
	P (mm)	1845	3378	2515	3378	4242	5969	6833	6833		
	A (mm)	1997	1235	1235	1235	1235	1235	1235	1235		
2590mm WF BACKSTOP	102T110WBC	102T110WBC	102T110WBC	102T110WBC	102T110WBC	102T110WBC	102T110WBC	102T110WBC	102T110WBC		
	102T110WYC	102T110WYC	102T110WYC	102T110WYC	102T110WYC	102T110WYC	102T110WYC	102T110WYC	102T110WYC		
	L (mm)	8357	8357	8357	8357	8357	8357	8357	8357		
	W1 (mm)	1753	1753	1753	1753	1753	1753	1753	1753		
	W2 (mm)	2515	2515	2515	2515	2515	2515	2515	2515		
	P (mm)	6833	6833	6833	6833	6833	6833	6833	6833		
	A (mm)	1235	1235	1235	1235	1235	1235	1235	1235		

**APPENDIX D
TRANSITIONS**

There are a variety of transition options available for the TAU-II system. The system was designed to be compatible with a variety of generic transitions already available to the industry.

Placement and installation of the TAU-II system and transitions must be accomplished in accordance with the guidelines and recommendations set forth in the “AASHTO Roadside Design Guide,” FHWA memoranda and other state and local standards.

There are different transition configurations depending on which backstop you are using (Compact or P.C.B.). Transition options for either of the backstop systems are shown in the following drawings.

DRAWINGS

PCB Backstop to Vertical Concrete 64
DWG# B010727

PCB Backstop to Safety Shape PCB 65
DWG# B10809

Compact Backstop to Safety Shape PCB .. 66
DWG# B010725

Compact Backstop to Safety Shape PCB
One Side..... 67
DWG# B010811

Compact backstop to Safety shape PCB
Offset 68
DWG# B010726

Compact Backstop to Concrete End Shoe 69
DWG# B010806

Compact Backstop to Thrie Beam Rail 70
DWG# B010724

Compact Backstop to W-Beam Rail 71
DWG# B010728

Transition to Median Barrier..... 72
DWG # B050606

Transition to Concrete Block 73
DWG#AP070406

Wide System to Bridge Pier
with Concrete Barrier 74
DWG#AP070405

Transition to Cylindrical Bridge Pier 75
DWG#AP070301

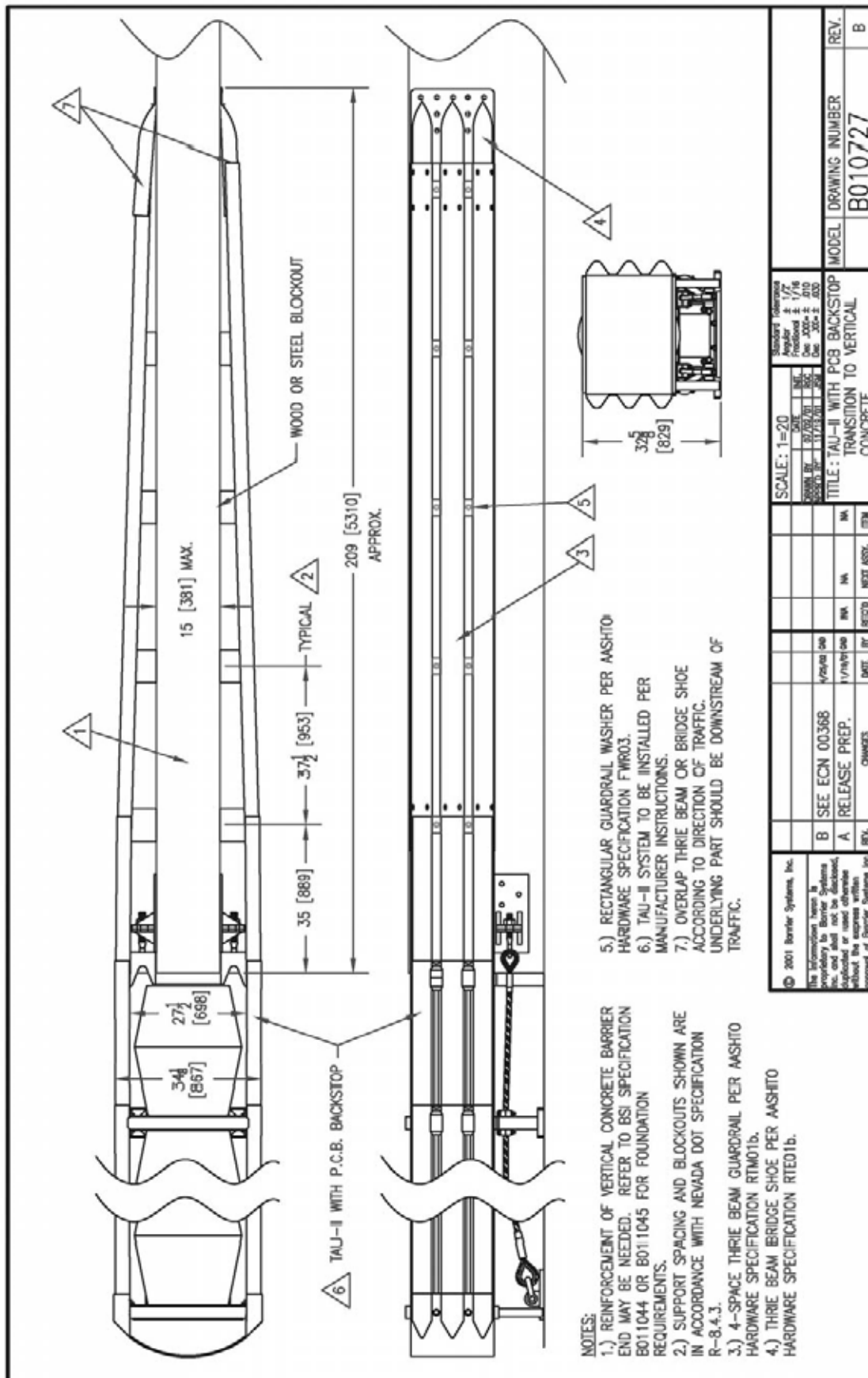

- NOTES:**
- 1.) REINFORCEMENT OF VERTICAL CONCRETE BARRIER END MAY BE NEEDED. REFER TO BSI SPECIFICATION B011044 OR B011045 FOR FOUNDATION REQUIREMENTS.
 - 2.) SUPPORT SPACING AND BLOCKOUTS SHOWN ARE IN ACCORDANCE WITH NEVADA DOT SPECIFICATION R-8.4.3.
 - 3.) 4-SPACE THRIE BEAM GUARDRAIL PER ASHTO HARDWARE SPECIFICATION RTM01b.
 - 4.) THRIE BEAM BRIDGE SHOE PER ASHTO HARDWARE SPECIFICATION RTE01b.
 - 5.) RECTANGULAR GUARDRAIL WASHER PER ASHTO HARDWARE SPECIFICATION FWR03.
 - 6.) TAU-II SYSTEM TO BE INSTALLED PER MANUFACTURER INSTRUCTIONS.
 - 7.) OVERLAP THRIE BEAM OR BRIDGE SHOE ACCORDING TO DIRECTION OF TRAFFIC. UNDERLYING PART SHOULD BE DOWNSTREAM OF TRAFFIC.

© 2001 Barrier Systems, Inc.		SCALE: 1=20		Standard Reference	
The information herein is property of Barrier Systems, Inc. and shall not be disclosed, reproduced or used otherwise without the express written approval of Barrier Systems, Inc.		DATE	DATE	Angular	± 1/2°
B	SEE ECN 00368	07/02/01	05/01/01	Fractional	± 1/16
A	RELEASE PREP.	11/23/01	05/01/01	Dec	XXX ± .010
REV.	CHANGES	DATE	BY	Dec	.XX ± .000
				TITLE: TAU-II WITH PCB BACKSTOP TRANSITION TO VERTICAL CONCRETE	
				MODEL	DRAWING NUMBER
					B010727
				REV.	B

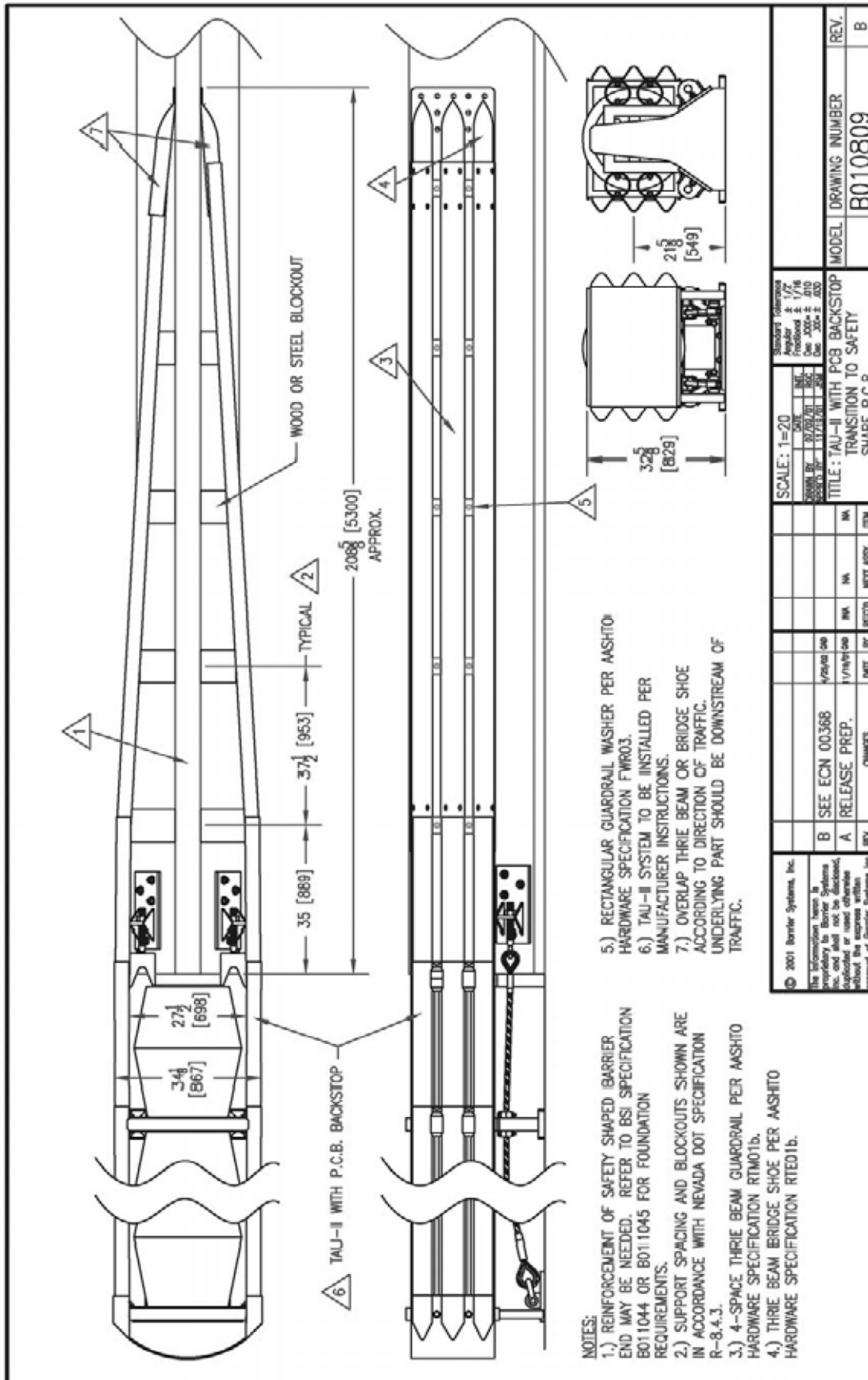

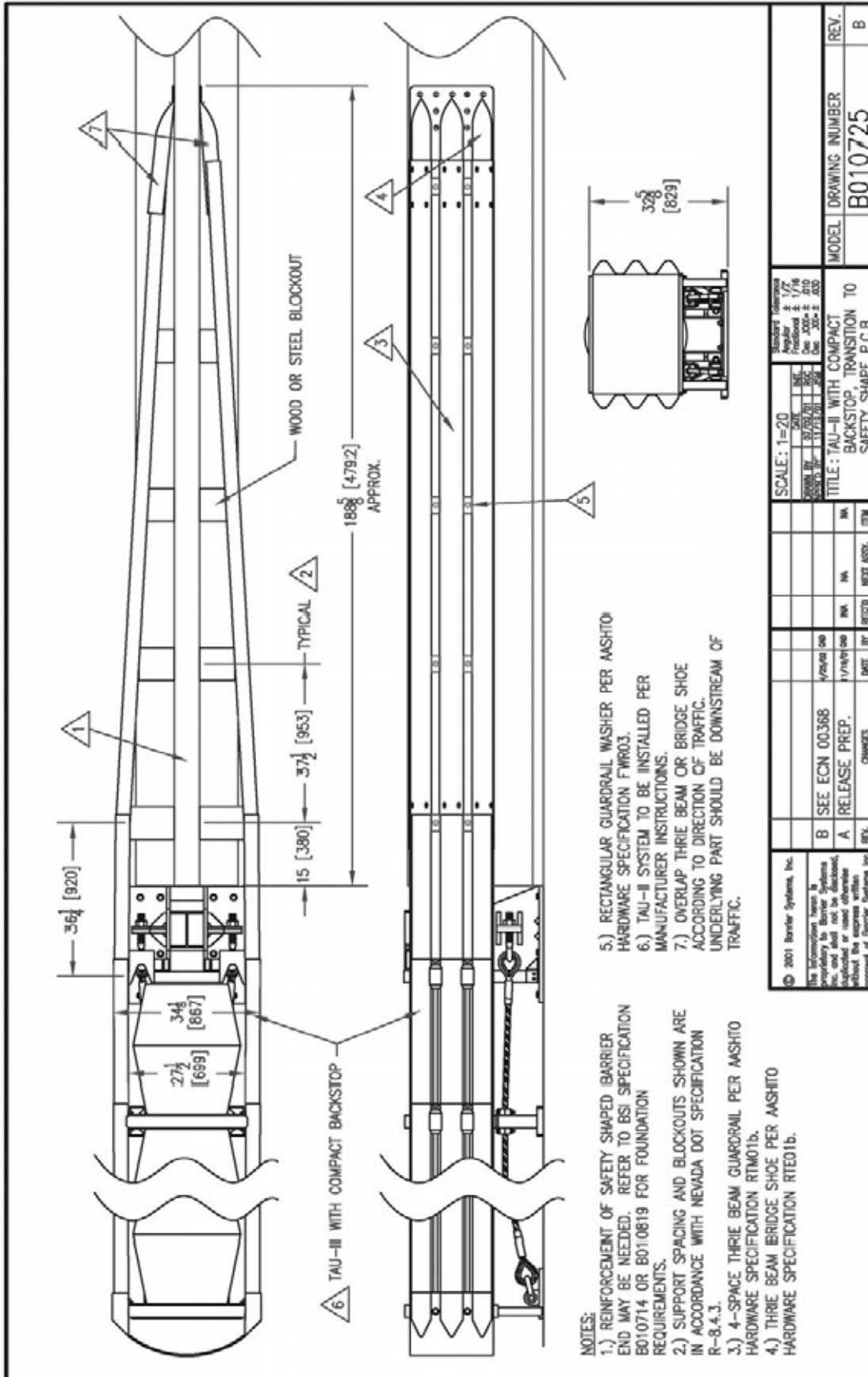

- NOTES:**
- 1.) REINFORCEMENT OF SAFETY SHAPED BARRIER END MAY BE NEEDED. REFER TO BSI SPECIFICATION B010714 OR B010819 FOR FOUNDATION REQUIREMENTS.
 - 2.) SUPPORT SPACING AND BLOCKOUTS SHOWN ARE IN ACCORDANCE WITH NEVADA DOT SPECIFICATION R-8.4.3.
 - 3.) 4-SPACE THREE BEAM GUARDRAIL PER ASHTO HARDWARE SPECIFICATION RTM01b.
 - 4.) THREE BEAM BRIDGE SHOE PER ASHTO HARDWARE SPECIFICATION RTE01b.
 - 5.) RECTANGULAR GUARDRAIL WASHER PER ASHTO HARDWARE SPECIFICATION FWR03.
 - 6.) TAU-II SYSTEM TO BE INSTALLED PER MANUFACTURER INSTRUCTIONS.
 - 7.) OVERLAP THREE BEAM OR BRIDGE SHOE ACCORDING TO DIRECTION OF TRAFFIC. UNDERLYING PART SHOULD BE DOWNSTREAM OF TRAFFIC.

SCALE: 1=20 Standard Reference: Angular ± 1/2° Fractional ± 1/16 Dec ± .010 DIMS IN INCHES DIMS IN MILLIMETERS		DATE: 11/23/01 BY: [Signature] CHECKED BY: [Signature]	MODEL: B010725 DRAWING NUMBER: B REV.
TITLE: TAU-II WITH COMPACT BACKSTOP, TRANSITION TO SAFETY SHAPE P.C.B		REVISIONS:	REV. B
B SEE ECN 00368 A RELEASE PREP.	DATE BY: 1/14/02 CHANGES:	INK: [Signature] NEXT ASSY. ITEM:	INK: [Signature] ITEM:
<small>© 2001 Barrier Systems, Inc. The information herein is the property of Barrier Systems, Inc. and shall not be disclosed, reproduced or used otherwise without the express written approval of Barrier Systems, Inc.</small>			

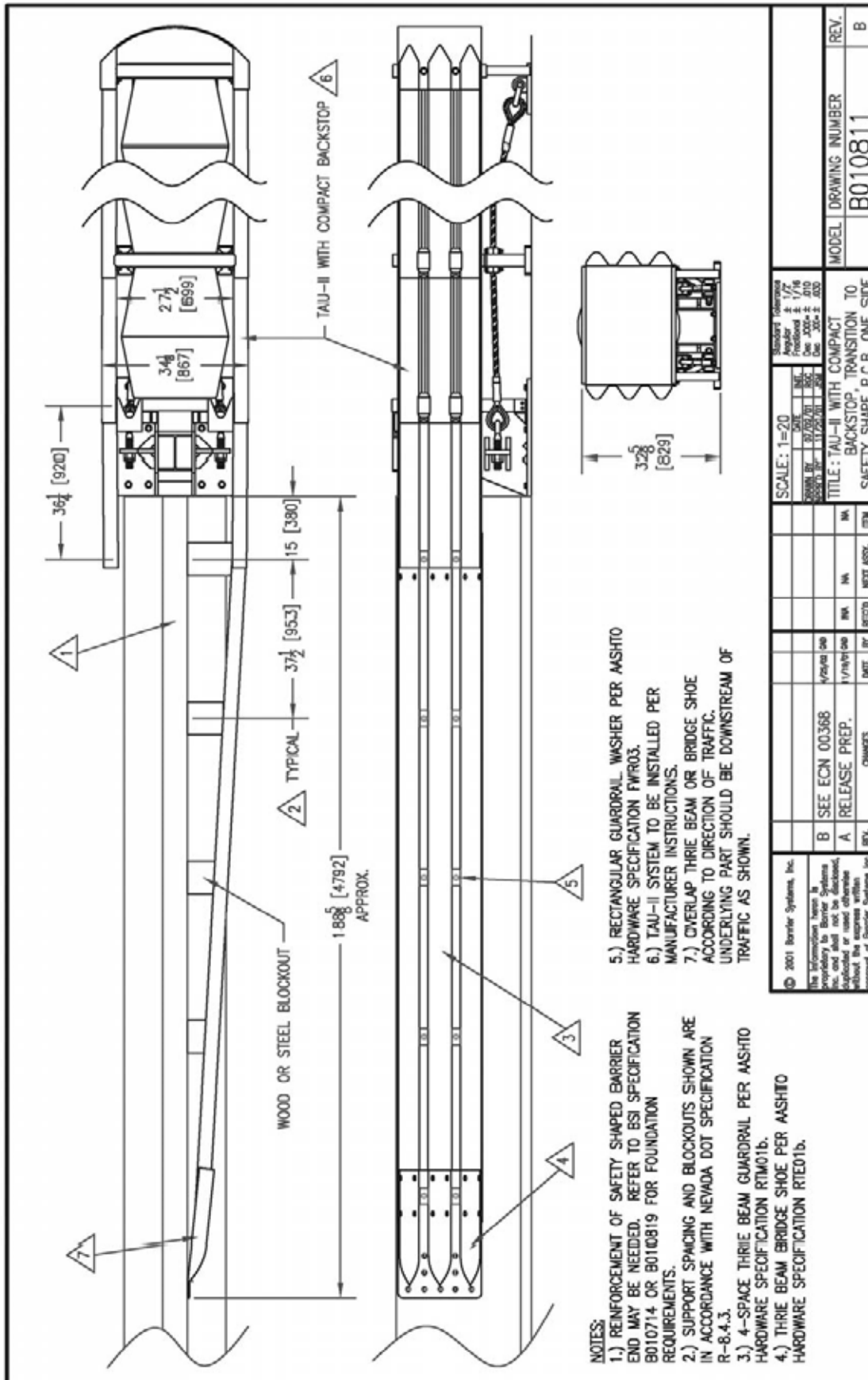

- NOTES:**
- 1.) REINFORCEMENT OF SAFETY SHAPED BARRIER END MAY BE NEEDED. REFER TO BSI SPECIFICATION B010714 OR B010819 FOR FOUNDATION REQUIREMENTS.
 - 2.) SUPPORT SPACING AND BLOCKOUTS SHOWN ARE IN ACCORDANCE WITH NEVADA DOT SPECIFICATION R-8.4.3.
 - 3.) 4-Space THREE BEAM GUARDRAIL PER AASHTO HARDWARE SPECIFICATION RTM01b.
 - 4.) THREE BEAM BRIDGE SHOE PER AASHTO HARDWARE SPECIFICATION RTE01b.
 - 5.) RECTANGULAR GUARDRAIL WASHER PER AASHTO HARDWARE SPECIFICATION FWPRO3.
 - 6.) TAU-II SYSTEM TO BE INSTALLED PER MANUFACTURER INSTRUCTIONS.
 - 7.) COVERLAP THREE BEAM OR BRIDGE SHOE ACCORDING TO DIRECTION OF TRAFFIC. UNDERLYING PART SHOULD BE DOWNSTREAM OF TRAFFIC AS SHOWN.

© 2001 Barrier Systems, Inc. The information herein is proprietary to Barrier Systems and is not to be reproduced or used otherwise without the express written approval of Barrier Systems Inc.			SCALE: 1=20	Standard Allowance Angular ± 1/16 Linear ± .010 Din ± .005 Dia ± .005	MODEL	DRAWING NUMBER	REV.
B	SEE ECN 00368	1/26/01	325	[829]	TAU-II WITH COMPACT BACKSTOP, TRANSITION TO SAFETY SHAPE P.C.B. ONE SIDE	B010811	B
A	RELEASE PREP.	1/19/01					
		CHANGES	DATE BY	RECD BY	MA	MA	REV.

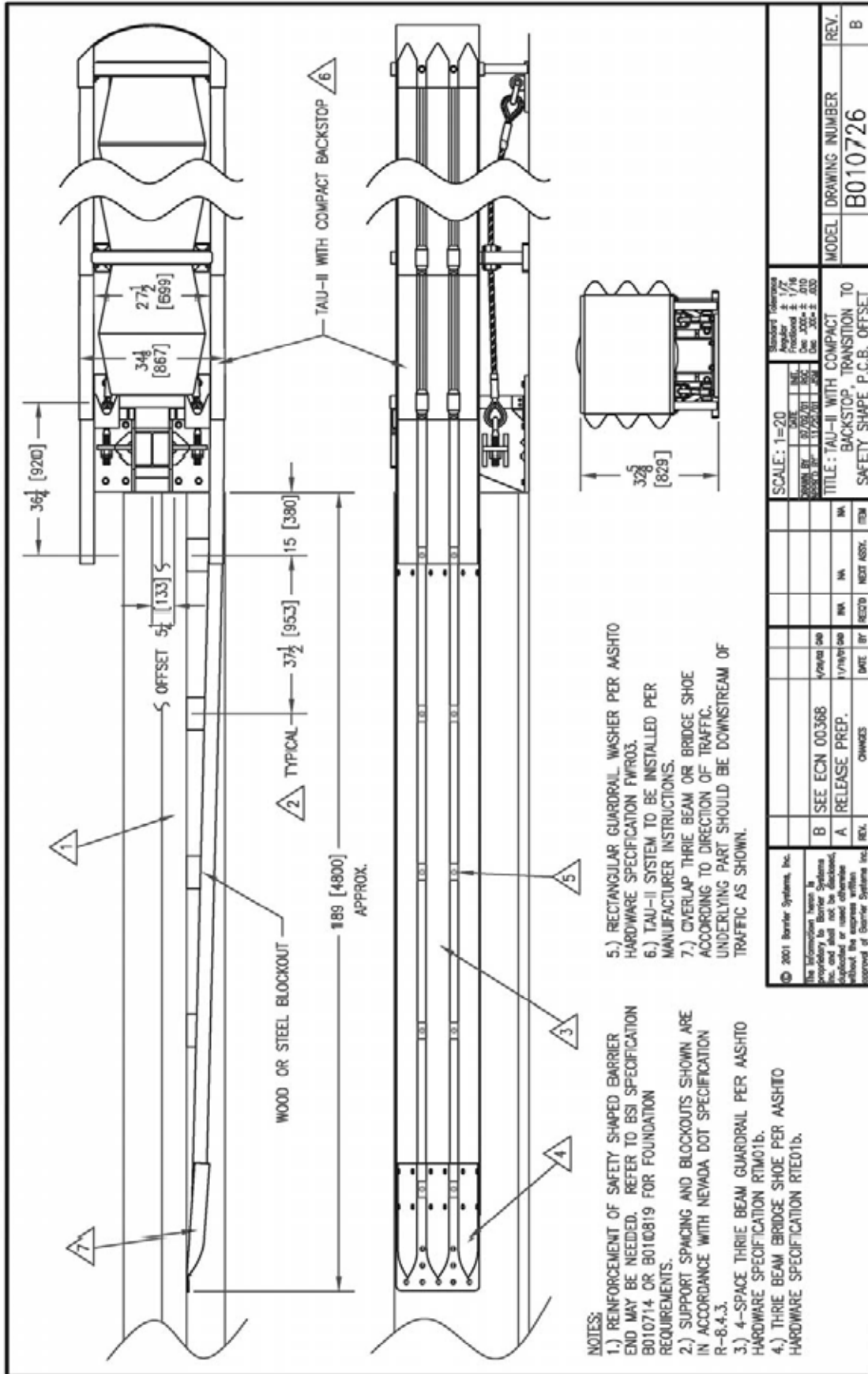

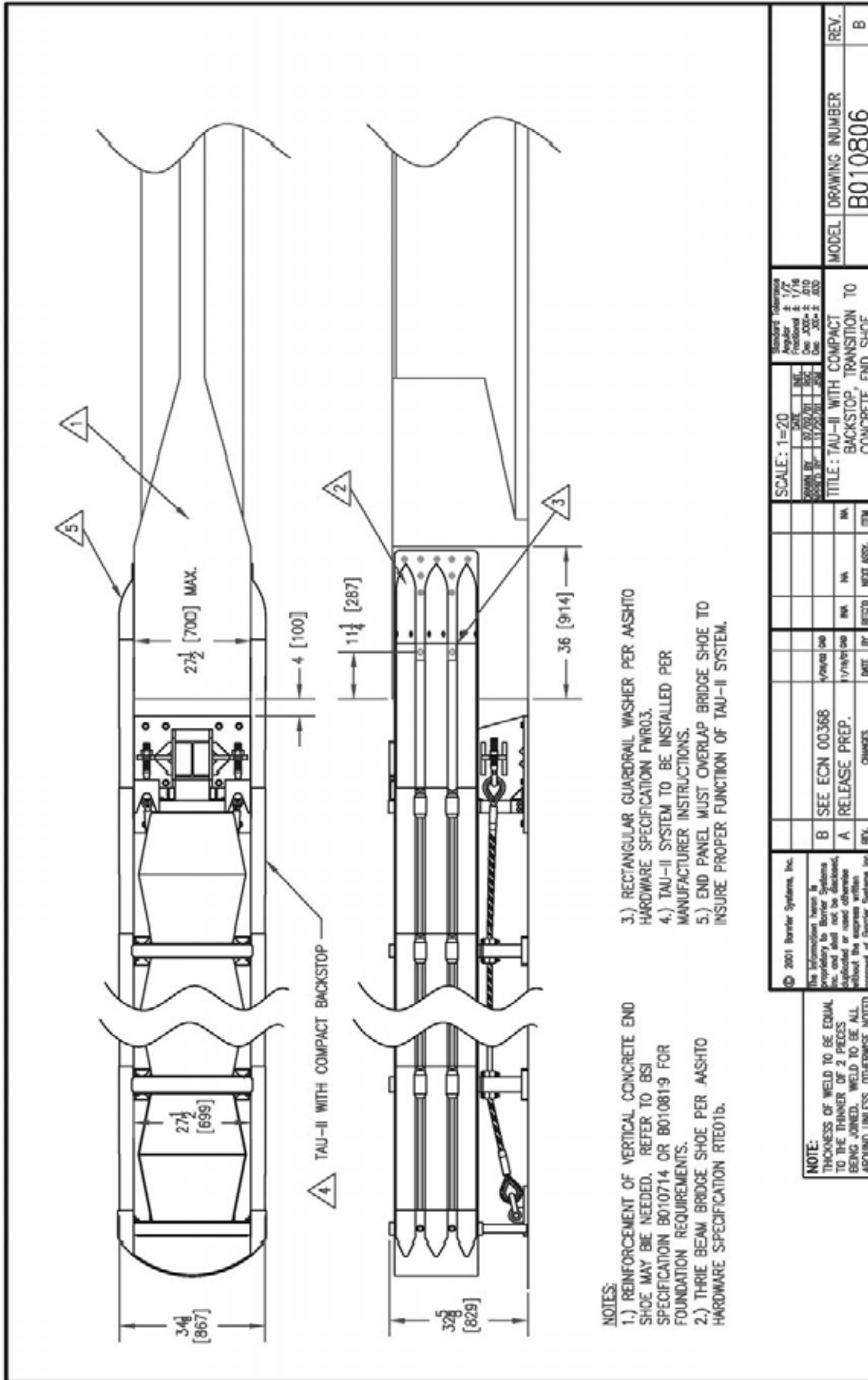

- NOTES:
- 1.) REINFORCEMENT OF VERTICAL CONCRETE END SHOE MAY BE NEEDED. REFER TO BSI SPECIFICATION B010714 OR B010819 FOR FOUNDATION REQUIREMENTS.
 - 2.) THRILL BEAM BRIDGE SHOE PER AASHTO HARDWARE SPECIFICATION RTE01b.
 - 3.) RECTANGULAR GUARDRAIL WASHER PER AASHTO HARDWARE SPECIFICATION FWR03.
 - 4.) TAU-II SYSTEM TO BE INSTALLED PER MANUFACTURER INSTRUCTIONS.
 - 5.) END PANEL MUST OVERLAP BRIDGE SHOE TO INSURE PROPER FUNCTION OF TAU-II SYSTEM.

© 2001 Barrier Systems, Inc. This information is proprietary to Barrier Systems, Inc. and shall not be disclosed, copied, or used without the express written approval of Barrier Systems, Inc.		SCALE: 1=20 DIMENSIONS IN INCHES DECIMALS ± 1/16 FRACTIONS ± 1/16 ANGLES ± 30' UNLESS OTHERWISE SPECIFIED	MODEL DRAWING NUMBER REV.
B SEE ECN 00368 A RELEASE PREP.	DATE BY CHANGES	TITLE: TAU-II WITH COMPACT BACKSTOP, TRANSITION TO CONCRETE END SHOE	MODEL DRAWING NUMBER REV.
REV.	DATE BY CHANGES	TITLE: TAU-II WITH COMPACT BACKSTOP, TRANSITION TO CONCRETE END SHOE	MODEL DRAWING NUMBER REV.
REV.	DATE BY CHANGES	TITLE: TAU-II WITH COMPACT BACKSTOP, TRANSITION TO CONCRETE END SHOE	MODEL DRAWING NUMBER REV.

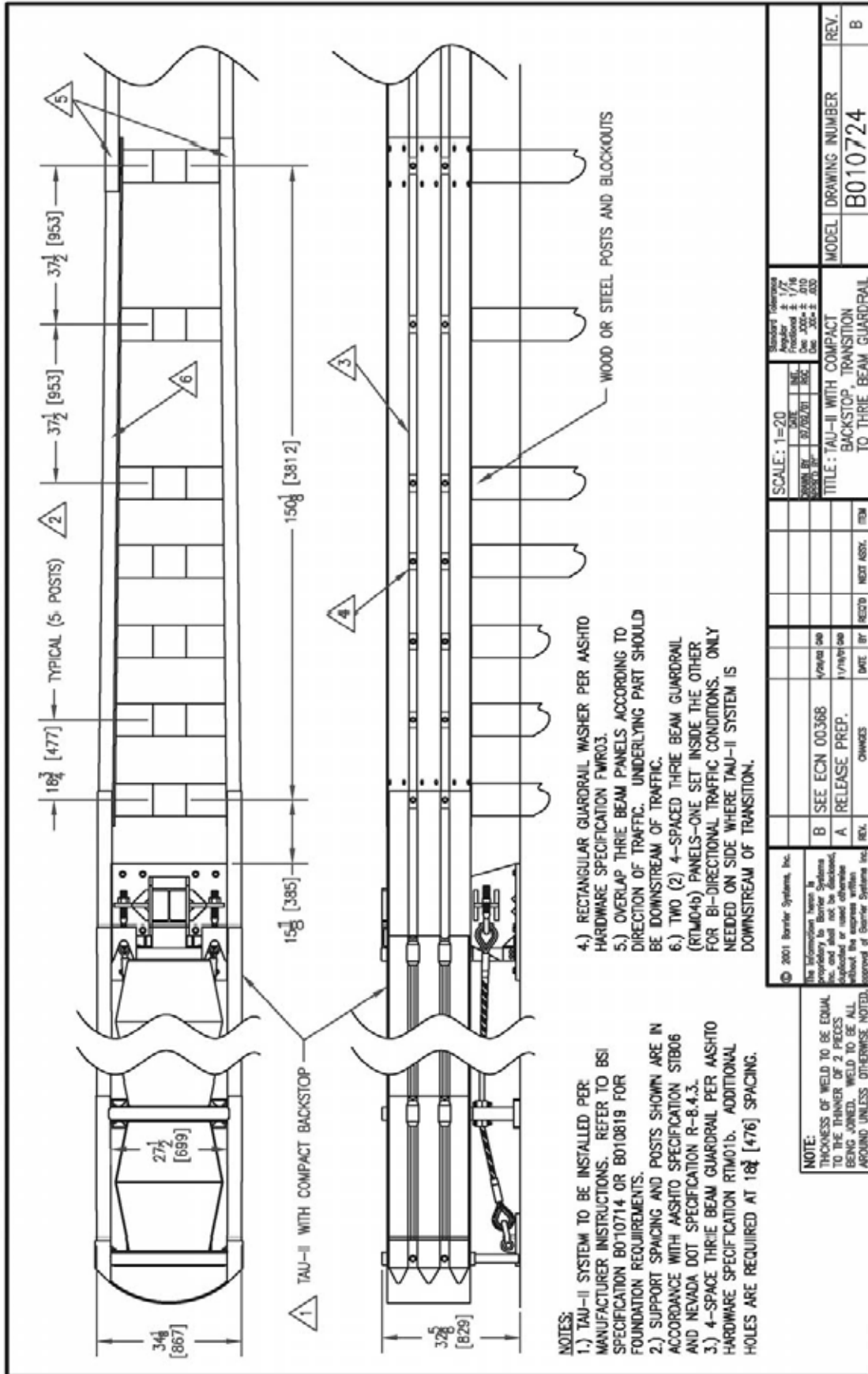

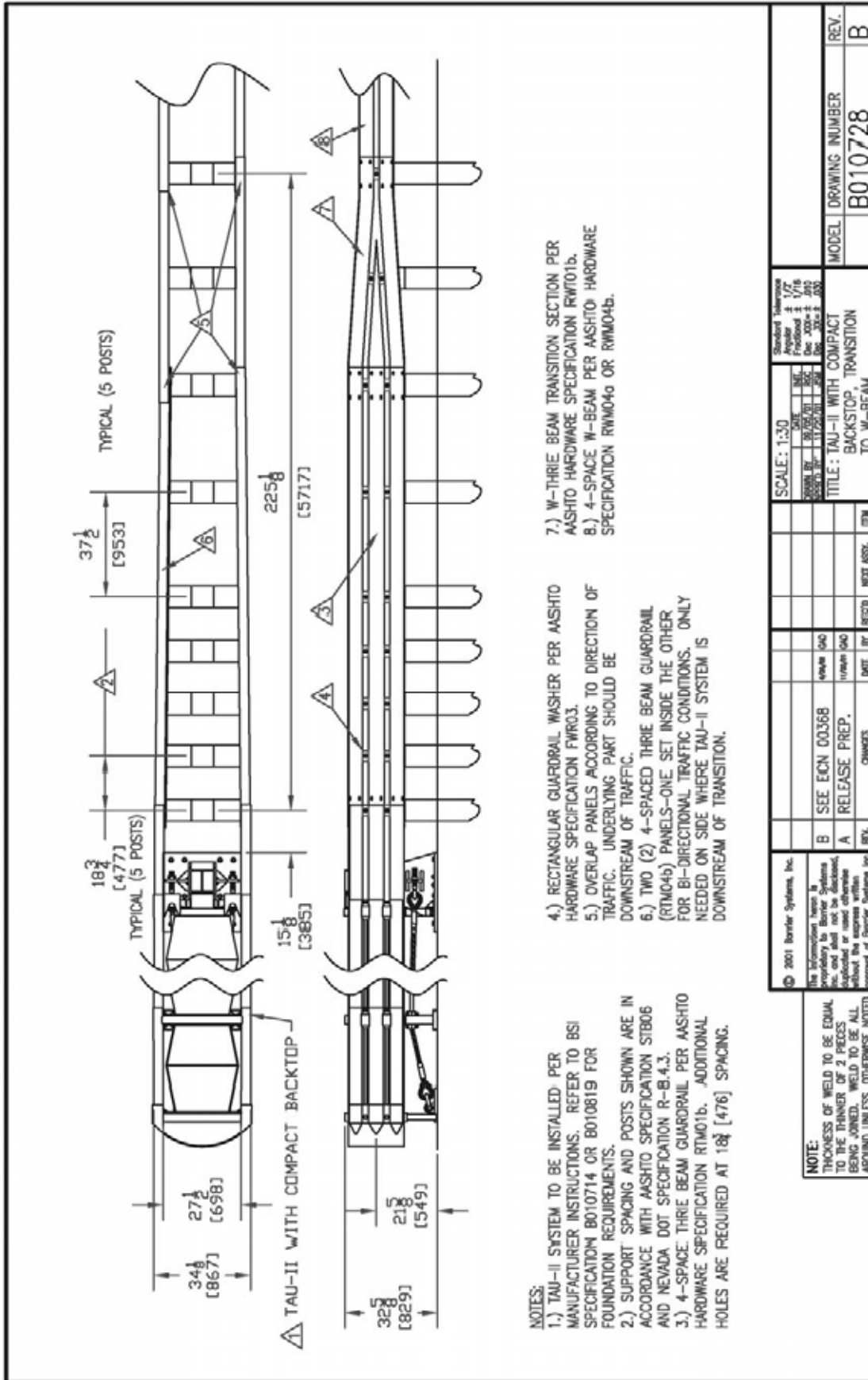

COMPACT BACKSTOP SHOWN. TRANSITION IS COMPATIBLE WITH PCB BACKSTOP, FLUSH MOUNT BACKSTOP, AND WIDE FLANGE BACKSTOP. SEE LENGTH TABLE FOR TRANSITION POSITIONING PER BACKSTOP.

UNIVERSAL TAU-II SYSTEM

TRANSITION

TRANSITION BRACKET

BLOCK OUT

RECTANGULAR GUARDRAIL WASHER

THREE BEAM TERMINAL CONNECTOR

RECTANGULAR GUARDRAIL

UNIVERSAL TAU-II END PANEL

(2) NESTED UNIVERSAL TAU-II ANGLED END PANEL

UNIVERSAL TAU-II SLIDING PANEL

UNIVERSAL TAU-II SYSTEM

SEE TABLE

LENGTH "L"

BACKSTOP	IN	MM
COMPACT	74 3/4	1900
PCB	94 3/4	2400
FLUSH MOUNT	89 3/8	2270
WIDE FLANGE	128 1/2	3260

NOTES:

- UNIVERSAL TAU-II SYSTEM TO BE INSTALLED PER MANUFACTURERS INSTRUCTIONS.
- TRANSITION SHOWN IS COMPATIBLE WITH COMPACT BACKSTOP (SHOWN), FLUSH MOUNT BACKSTOP, PCB BACKSTOP, AND WIDE FLANGE BACKSTOP. IT IS APPLICABLE WITH ASPHALT ANCHORING PACKAGES FOR PCB BACKSTOP AND PCB BRACE KIT FOR COMPACT BACKSTOP.
- THREE BEAM TERMINAL CONNECTOR PER ASHTO HARDWARE SPECIFICATION (P10).
- STANDARD TIMBER OR PLASTIC OFFSET BLOCKS FIELD TRIMMED FOR USE. BLOCK OUT DETAIL SHOWS DIMENSIONS FOR F-SHAPE SAFETY SHAPED BARRIER. ACTUAL DIMENSIONS SHOULD REFLECT SHAPE OF BARRIER TRANSITIONED TO.
- PANELS AND BLOCKOUT ATTACHED TO BARRIER WALL WITH 5/8" BEAM WASHER. 20" [500mm] BOLTS MAY BE FIELD TRIMMED. LENGTH MAY VARY WITH DIFFERENT BARRIER SHAPES. HOLES DRILLED THROUGH MEDIUM BARRIER ARE 3/4" [50mm]. MECHANICAL OR CHEMICALLY SHEAR AND PULL OUT STRENGTH TO MEET OREGONEE 15,000 LBF SPECIFICATION (P10).
- ATTACH THREE BEAM TERMINAL CONNECTOR TO MEDIUM BARRIER WITH (3) 5/8" [16mm] BOLTS WITH WASHERS AND NUT WITH WASHERS AND BEAM WASHERS. REFERENCE NOTE 5 FOR DETAILS.
- ATTACH THREE BEAM TERMINAL CONNECTOR TO UNIVERSAL TAU-II END PANEL WITH 5/8" [16mm] X 2" [50mm] BOLTS WITH BEAM WASHER AND NUT WITH WASHER.
- TRANSITION BRACKET TO BE INSTALLED OVER PIPE PANEL MOUNTS UNDER THE (2) NESTED ANGLED END PANELS AND THE SLIDING PANEL. BEND IN TRANSITION BRACKET FACES TO BE INSTALLED WITH SLIDING BOLTS. SLIDING BOLTS TO BE TORQUED PER MANUFACTURERS SPECIFICATIONS.

SCALE: 1:25

DATE: [REDACTED]

DESIGNED BY: [REDACTED]

DATE: [REDACTED]

SCALE: 1:25

Angular: ±1.0 Deg

Precision: ±.010

UNIT: INCH

STANDARD: ASME Y14.5

DATE: 3/17/05

DOC: 300-4-000

TITLE: UNIVERSAL TAU-II TRANSITION TO MEDIAN BARRIER

MODEL: DRAWING NUMBER

REV: B050606

REV	CHANGES	DATE	BY	RECD	NEXT ASSY	ITEM
1			NA			1

© 2006 Barmer Systems Inc. The information herein is proprietary to Barmer Systems Inc. shall not be disclosed, duplicated or used otherwise without the written approval of Barmer Systems Inc.

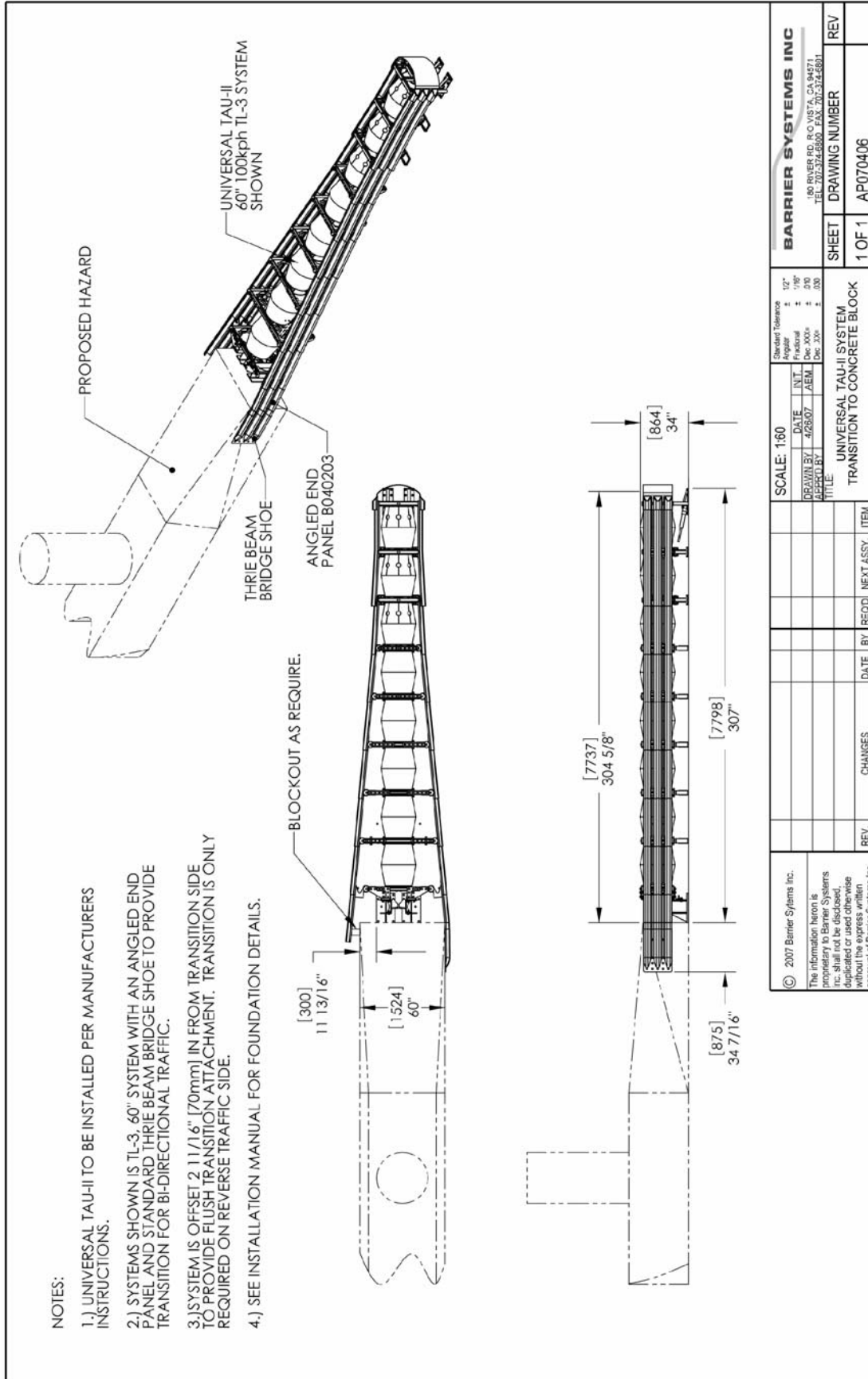

© 2007 Barrier Systems Inc. The information herein is proprietary to Barrier Systems Inc. shall not be disclosed, duplicated or used otherwise without the express written approval of Barrier Systems Inc.		SCALE: 1:60 DRAWN BY: 4/28/07 CHECKED BY: AEM DATE: 4/28/07 INT. AEM DEC. 2006 DEC. 2006 DEC. 2006	Standard Tolerance Angular ± 1/2° Prismatic ± 1/16" Dec. 2006 Dec. 2006 Dec. 2006	BARRIER SYSTEMS INC 180 RIVER RD, R.O. VISTA, CA 94571 TEL: 707-374-6800 FAX: 707-374-6801		
REV.	CHANGES	DATE	BY	RECD	NEXT ASSY.	ITEM
TITLE: UNIVERSAL TAU-II SYSTEM TRANSITION TO CONCRETE BLOCK				SHEET	DRAWING NUMBER	REV
				1 OF 1	AP070406	

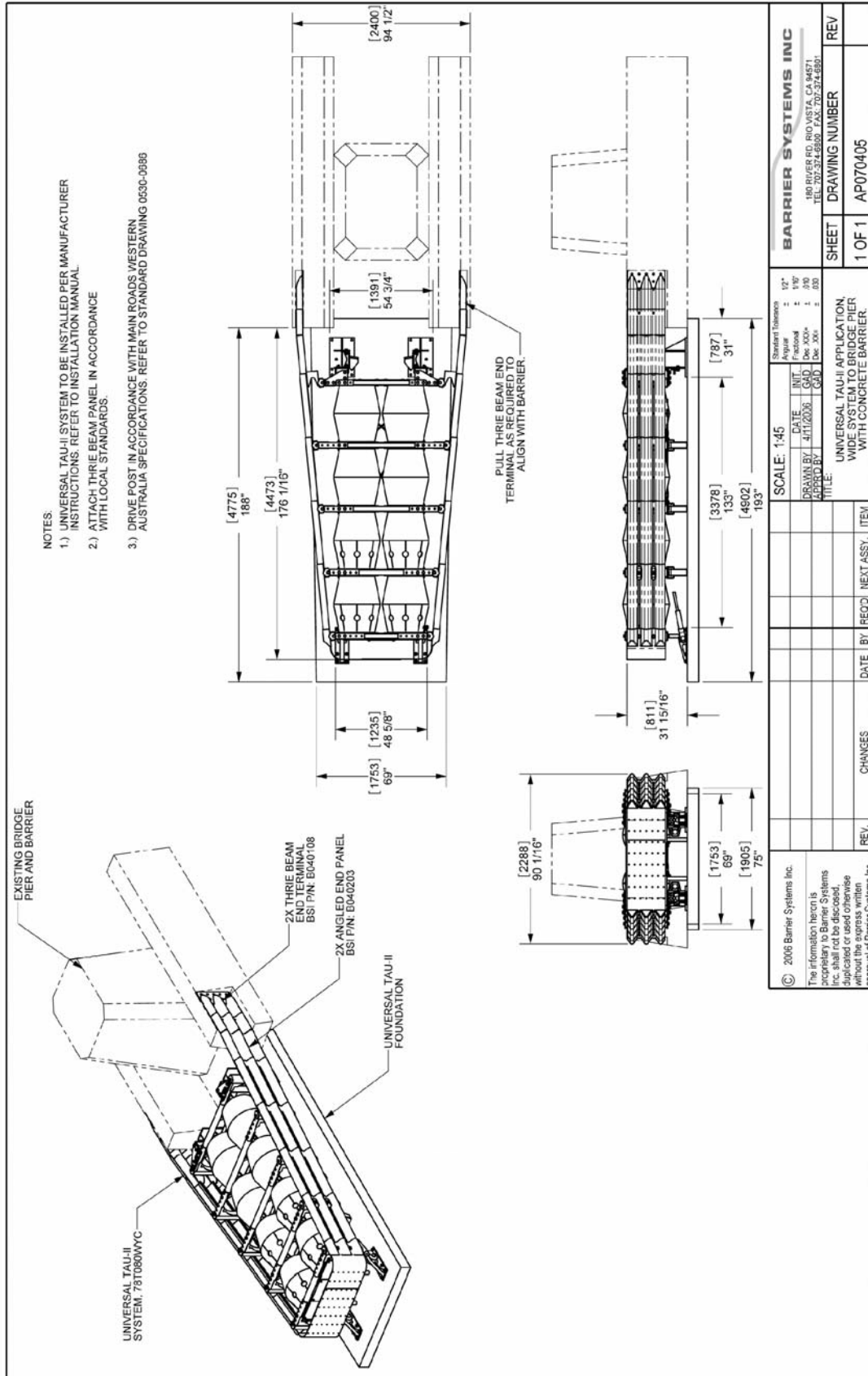

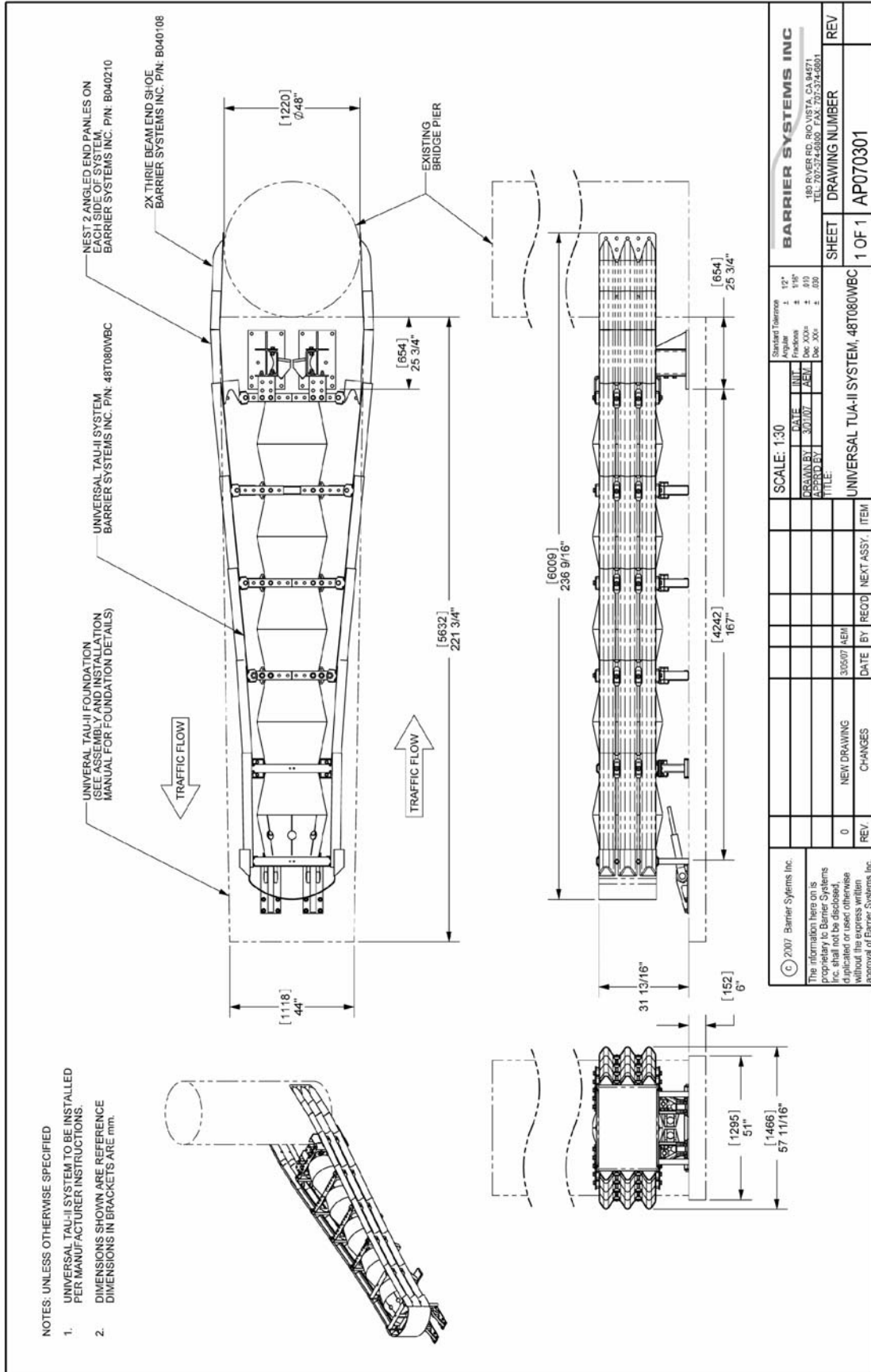

BARRIER SYSTEMS INC. 189 CALVER RD. RICHMOND, CA 94871 TEL: 707-274-8080 FAX: 707-274-6931	
SCALE: 1:30 DRAWN BY: JRM CHECKED BY: JRM DATE: 3/3/07 TITLE: UNIVERSAL TAU-II SYSTEM, 48T080WBC	Standard Tolerance 1. 1/2" 2. 1/8" 3. 1/16" 4. .005 5. .002
SHEET: 1 OF 1 DRAWING NUMBER: AP070301	REV: 0 NEW DRAWING DATE: 3/3/07 BY: JRM RECD: [] NEXT ASSY: [] ITEM: []

© 2007 Barrier Systems Inc.
 The information here on is proprietary to Barrier Systems Inc. shall not be disclosed, duplicated or used otherwise without the express written approval of Barrier Systems Inc.

Universal TAU-II® Attachment to BarrierGuard 800™ Installation Guide

Refer to the Universal TAU-II Installation and Maintenance Manual for more information, introduction, system overview, required tools, and other considerations for the Universal TAU-II systems.

The Universal TAU-II system is installed after the BarrierGuard 800 is fully deployed, installed, and anchored. Reference the BarrierGuard 800 Design, Installation, and Maintenance Manual for complete information on the BarrierGuard 800 barrier system implementation and installation.

The Universal TAU-II system utilizes a monolithic backstop that bolts directly in place of the terminal cover of the BarrierGuard 800. The front cable anchor remains as the only foundation anchorage required for the Universal TAU-II system. The front cable anchor is to be anchored to the same foundation type as the end of the BarrierGuard 800 that it is attached to (PC Concrete or Asphaltic Concrete). Anchorage shall be in accordance with BSI specifications A040113.

Installation Procedure: *Each Procedure references a page number from the Universal TAU-II Installation Manual for further information –*

- 1.) Remove terminal cover from BarrierGuard 800 end section (if in place).
- 2.) Install and fasten Universal TAU-II BarrierGuard 800 Backstop in place. **(See diagram on next page).**
- 3.) Locate and position Front Cable anchor (see below). Drill and secure the appropriate anchors for the foundation used per BSI specification A040113. Use the Front Cable anchor as the drilling template. Use a BSI approved anchoring compound. See pages 12 & 13.
- 4.) Place the Middle Bulkheads along the centerline of the system spaced approximately 34" [865mm] apart. See page 13.
- 5.) Thread the guide Cables through the legs of the

Middle Bulkheads, threaded end first, starting from the front of the system. Loosely place the threaded end into the backstop lugs and spin the nut on to hold it in place. See pages 13 & 14.

- 6.) Pin the guide Cables to the Front Cable Anchor with the shackles. See page 14.
- 7.) Install Cable Guides. See pages 14 & 15.
- 8.) Attach Pipe Panel Mounts. See page 15.
- 9.) Install the End Panels and first Slider Panels starting at the Pipe Panel Mounts. If a transition is to be installed the End Panel will be replaced by the Angled End Panel. See page 16 & 72.
- 10.) Install Slider Panels. Start from the back of the system and move forward, overlapping the rearward panel. Secure the panels in place with the Slider Bolts. See pages 16 & 17.
- 11.) Install the Front Support, attach the Slider Panels, Nose Cover, and Leg Supports and connect to the first Middle Support with Slider Bolts. See page 18.
- 12.) Torque Slider Bolts and Front Panel Bolts and install Energy Absorbing Cartridges. See page 19.
- 13.) Apply tension to cables – Torque to specification. Ensure foundation anchors are properly cured. See page 20.

(See Installation Diagram on Next Page)

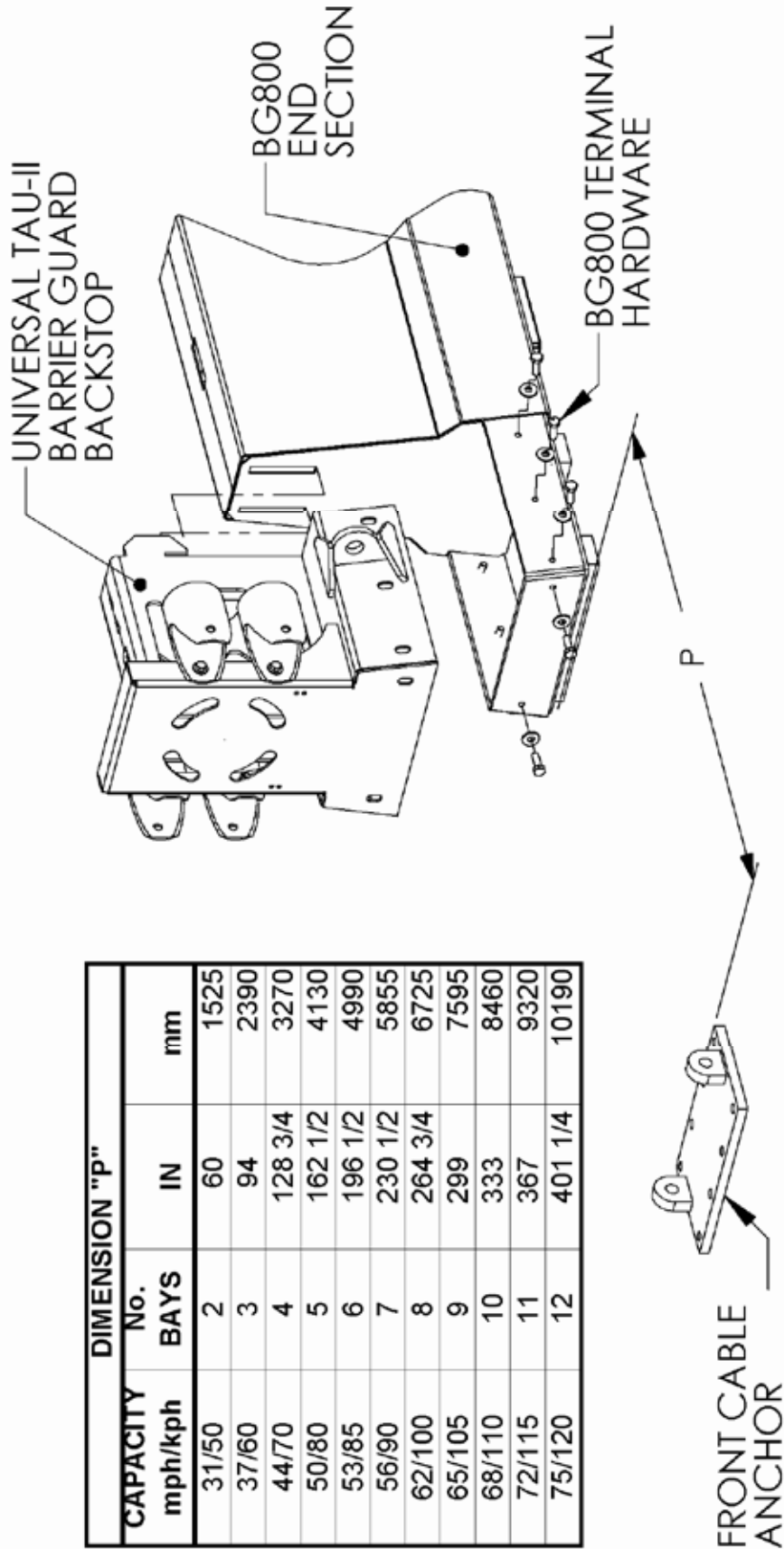

Notes



Lindsay Transportation Solutions Sales and Services, Inc

180 River Road • Rio Vista, CA 94571 • +1 707.374.6800 U.S. Toll Free: 888.800.3691 • www.barriersystemsinc.com

Installation manual details for the TAU-II System are subject to change without notice to reflect improvements and upgrades.

Additional information is available from Barrier Systems Sales and Service © Lindsay Transportation Solutions

TAU-II® INSTALLATION 05212014 v34