

5 PLAN DETAIL - TYPICAL WOOD TO MTL TRANSITION  
1:5

6 PLAN DETAIL - TYPICAL OUTSIDE CORNER-POLYCARB  
1:5

1 SECTION DETAIL - TYPICAL WINDOW  
1:5

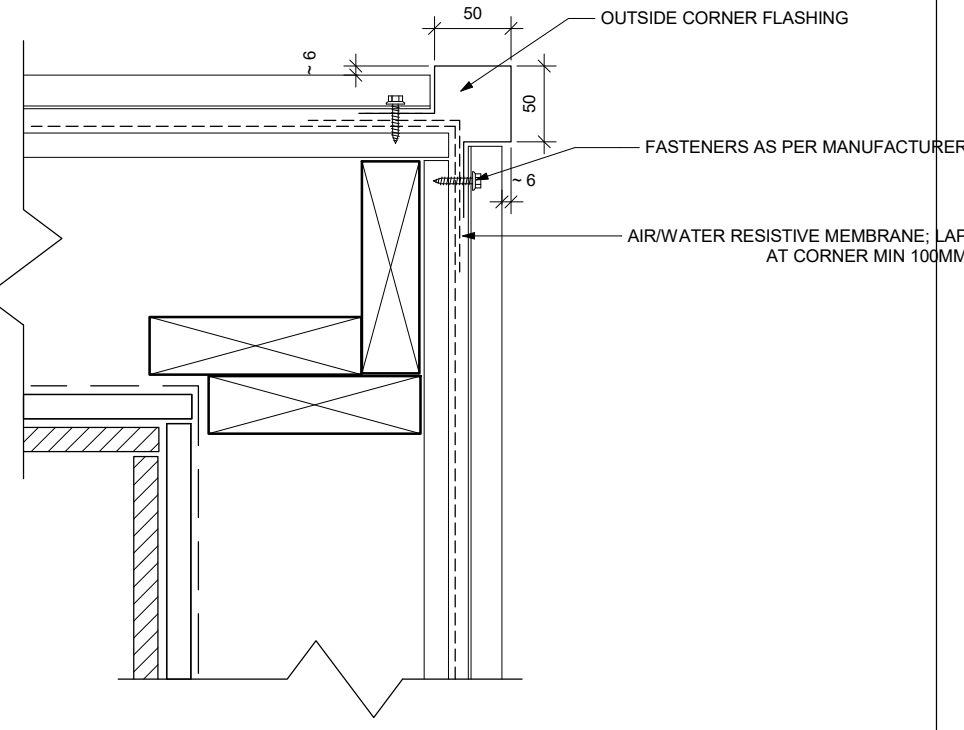
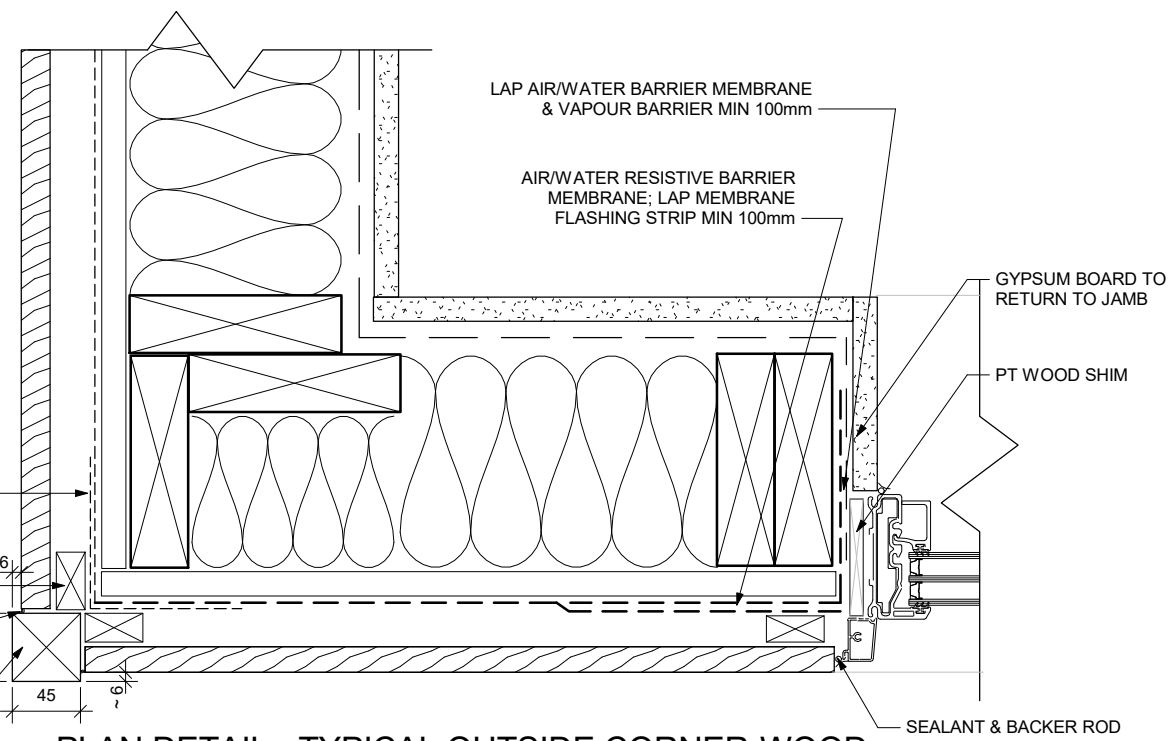

7 PLAN DETAIL - TYPICAL OUTSIDE CORNER-WOOD  
1:5

4 PLAN DETAIL - TYPICAL OUTSIDE CORNER  
1:5