

LAST SAVE: 2017/07/26 - 11:18am
 PATH: M:\644548\MENG\7FELE\DD - General DWG\1-0130L-E0014-001-00.dwg
 A1 SIZE - 594mm x 841mm

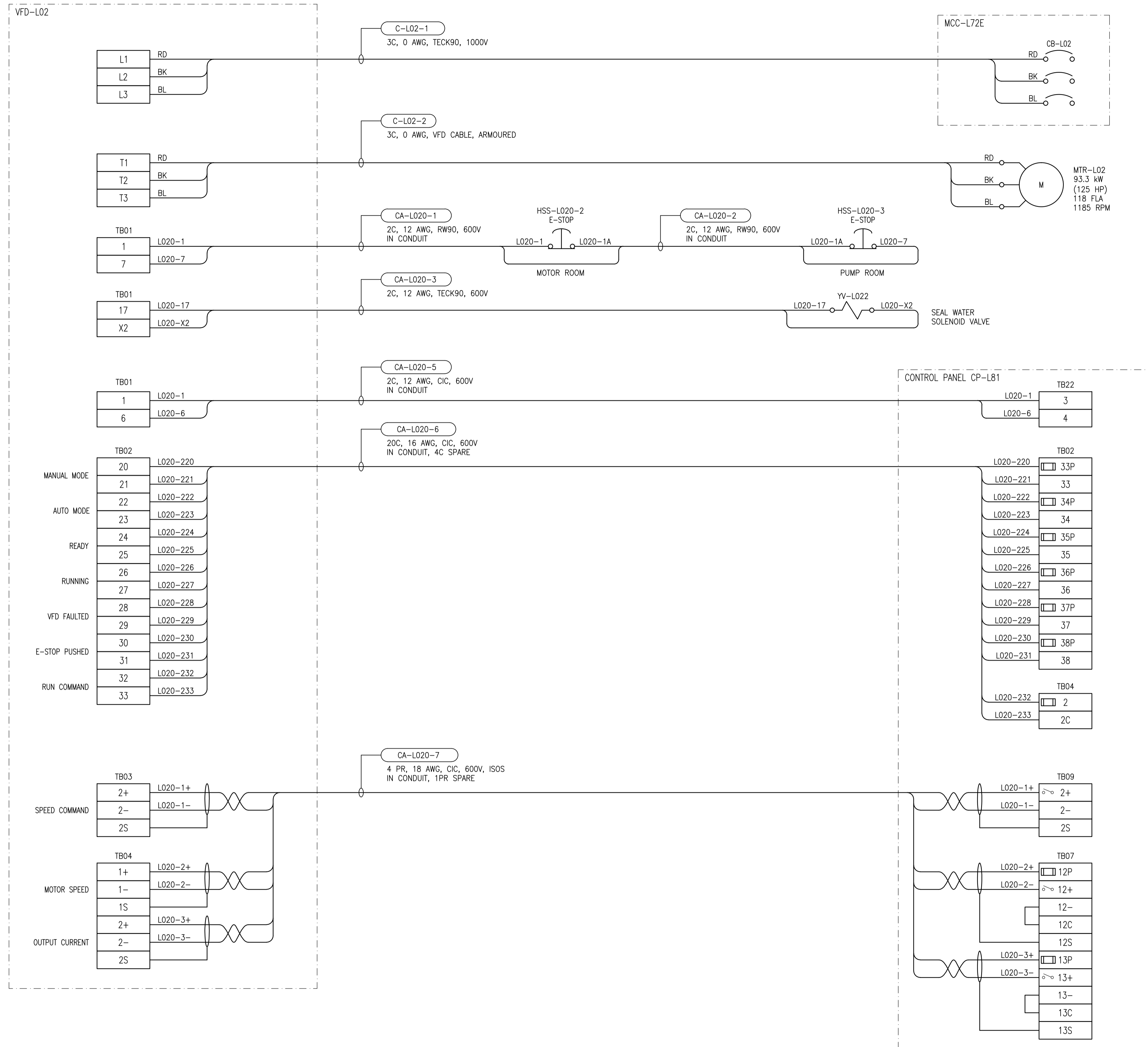

1-0130L-E0013	MOTOR STARTER SCHEMATIC
REFERENCE DRAWINGS	DESCRIPTION



NO.	REVISIONS	DATE	DESIGN	CHECK
00	ISSUED FOR TENDER, BID OPP. 639-2017	2017-07-25	BJC	TMC

SNC-LAVALIN INC.
 148 Nature Park Way
 Winnipeg, MB, Canada R3P 0X7
 204-786-8080

DESIGNED BY: B. CLEVEN
 DRAWN BY: S. BOGHOSIAN
 SCALE: NTS
 DATE: 2017/03/15
 CONSULTANT NO.:

CHECKED BY: T. CHURCH
 APPROVED BY: B. CLEVEN
 ISSUED FOR CONSTRUCTION BY:
 DATE:

ENGINEER'S SEAL
PRELIMINARY
 NOT TO BE
 USED FOR
 CONSTRUCTION

THE CITY OF WINNIPEG
 WATER AND WASTE DEPARTMENT

COMMUNITY ROW WASTEWATER PUMPING STATION
 2017 UPGRADES
 CONNECTION DIAGRAM
 VFD-L02
 WASTEWATER LIFT PUMP P-L02

CITY DRAWING NUMBER: 1-0130L-E0014
 SHEET: 001
 REV.: 00
 SIZE: A1