

THIS DRAWING AND ITS SUBJECT MATTER ARE DISCLOSED IN CONFIDENCE AND SHALL NOT BE REPRODUCED OR TRANSMITTED IN ANY FORM OR BY ANY MEANS WITHOUT THE WRITTEN CONSENT OF NEW FLYER INDUSTRIES LIMITED

Appendix F R1
860198-0157 (3.0)

DRAWING NO
202865

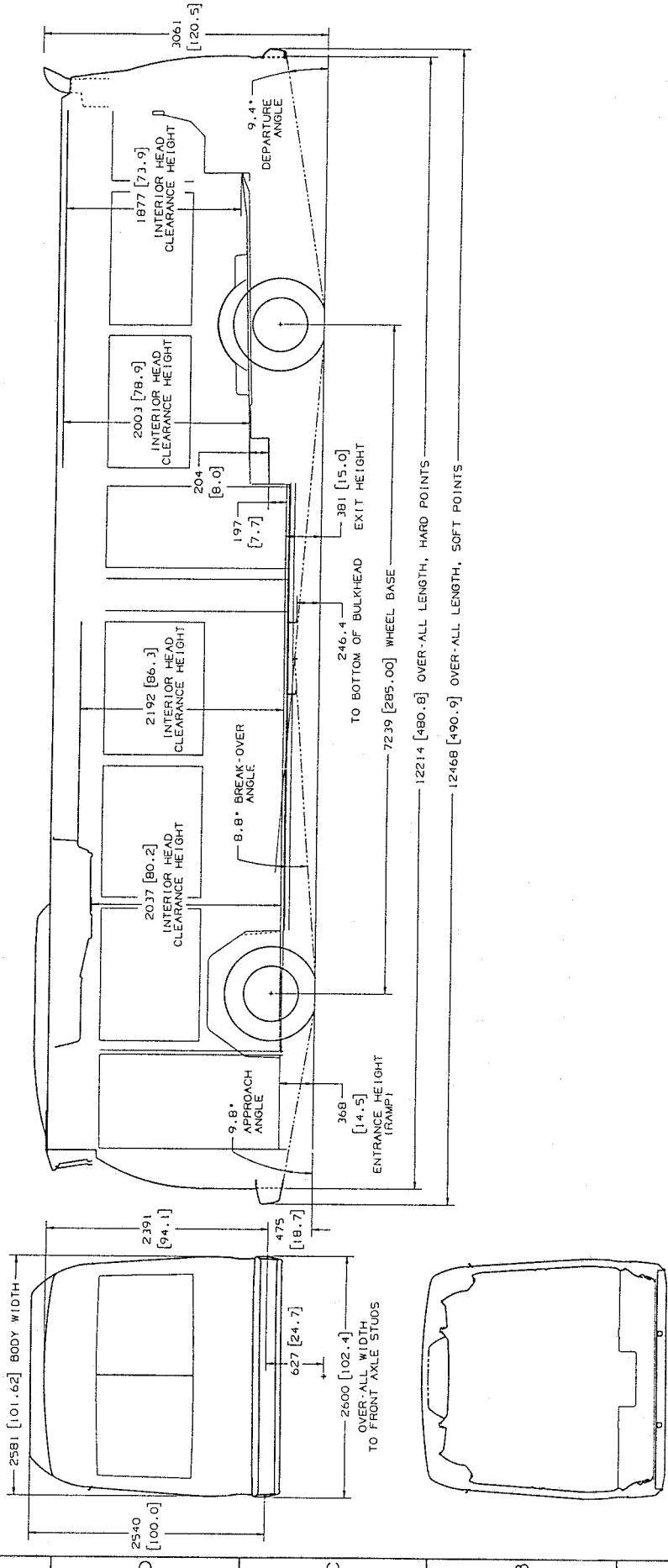

THE HEIGHT VALUES ABOVE ARE BASED ON A 305 TIRE LOADED RADIUS 18.7 [475], OVERALL DIA 39.8 [1011].

NOTICE: THIS DRAWING IS A FACSIMILE OF THE ELECTRONIC MASTER. ALL REVISIONS MUST BE MADE ELECTRONICALLY. MANUAL REVISION IS NOT ALLOWED.

NOTE: FOR INSTALLATION DRAWINGS PLEASE REFER TO ATTACHED MP BOX SHEET FOR PARTS LISTING

MATERIAL	WEIGHT	TOLERANCE	UNIT	SCALE	DATE	TITLE
					SEPT 1999	SPEC DRAWING - INVERO

BY	NAME	DATE	TITLE
DRW	G.T.	SEPT 1999	SPEC DRAWING - INVERO
CHK'D	ENG'R		
DO NOT SCALE	DO NOT SCALE		
AREA IN THIS DRAWING	AREA IN THIS DRAWING		

UNSPEC'D TOLS	METRIC	SCALE	DATE	TITLE
X.X	H.O.P.	1:1	SEPT 1999	SPEC DRAWING - INVERO
X.X	H.O.P.	1:1		
X.X	H.O.P.	1:1		
X.X	H.O.P.	1:1		
X.X	H.O.P.	1:1		

REV	DATE	BY	DESCRIPTION
1			

REV	DATE	BY	DESCRIPTION
1			

RELEASED TO PRODUCTION	REV	DATE	BY	DESCRIPTION

30 FT LOW FLOOR BUS
EXTERIOR DIMENSIONS

365.7 OUTSIDE OF BUMPERS

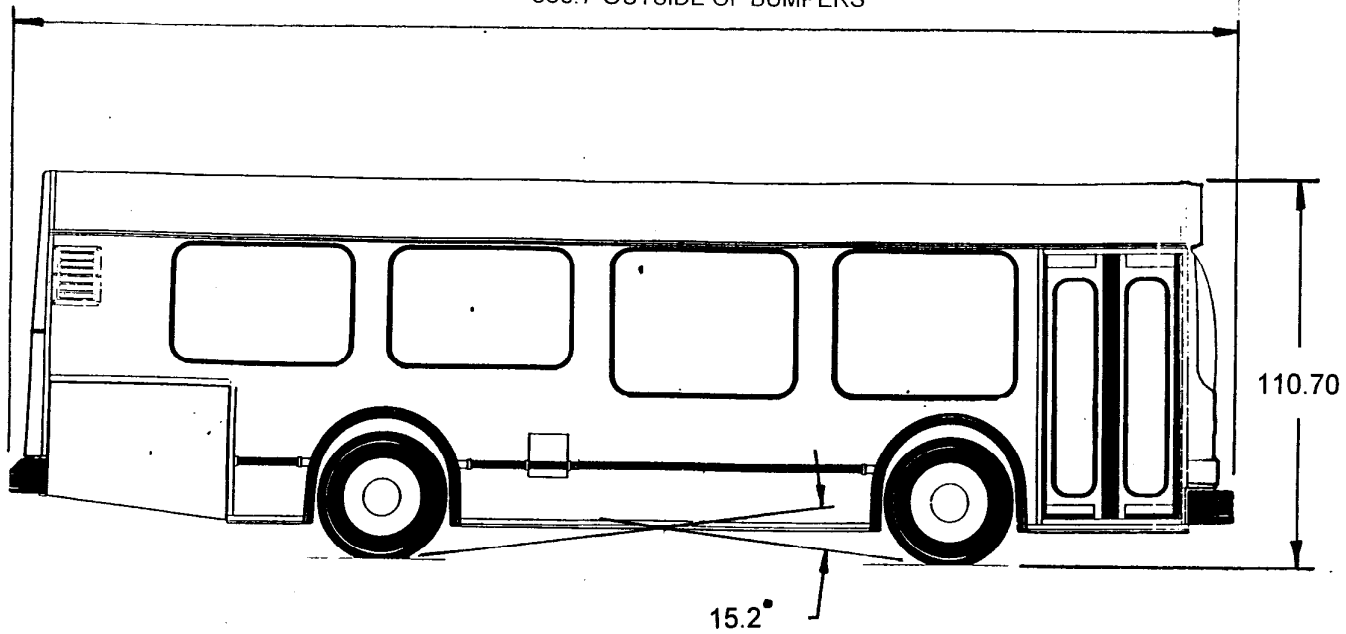

102.00

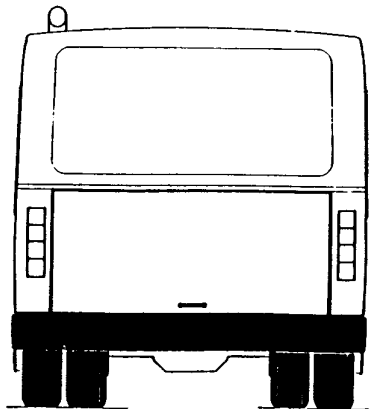
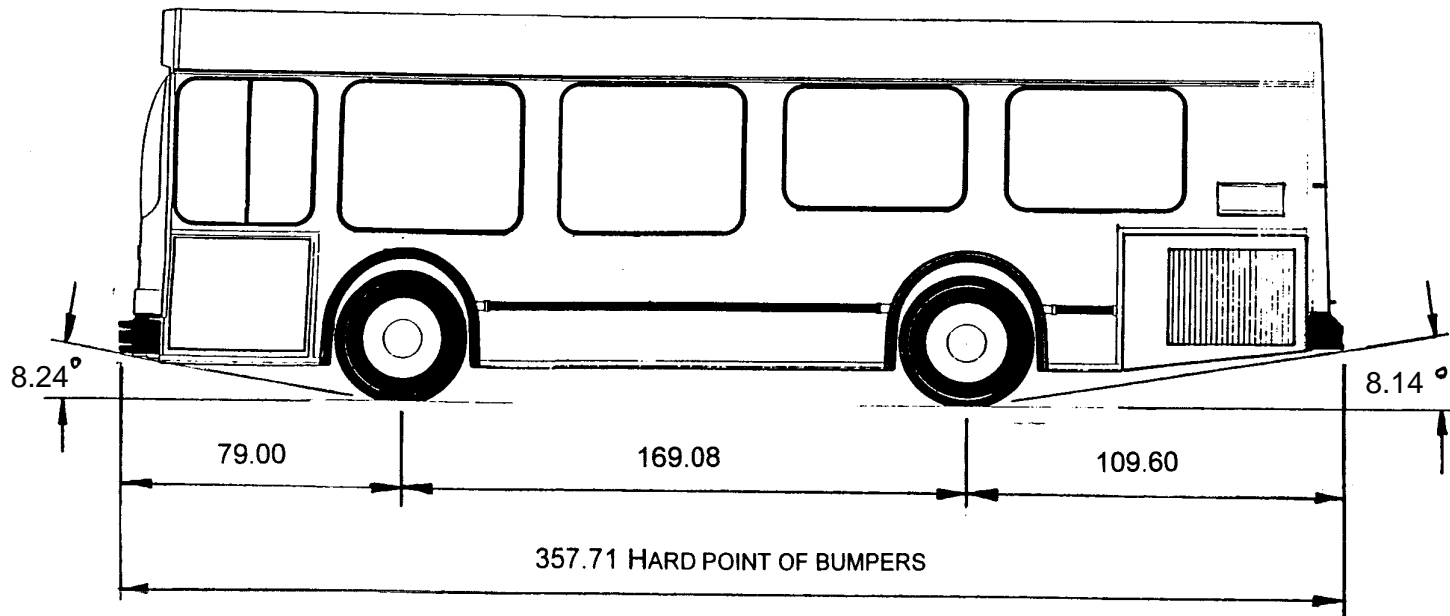
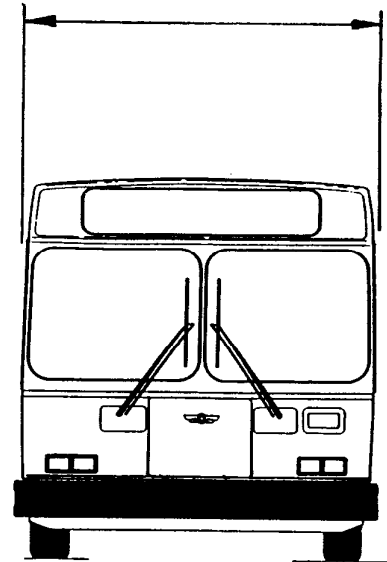

THIS DRAWING AND ITS CONTENTS ARE
 THE PROPERTY OF NEW PLYER INDUSTRIES LTD.
 AND SHALL NOT BE REPRODUCED OR
 TRANSMITTED IN ANY FORM OR BY ANY
 MEANS, ELECTRONIC OR MECHANICAL,
 INCLUDING PHOTOCOPYING, RECORDING,
 OR BY ANY INFORMATION STORAGE AND
 RETRIEVAL SYSTEM, WITHOUT THE
 WRITTEN PERMISSION OF NEW PLYER
 INDUSTRIES LIMITED.

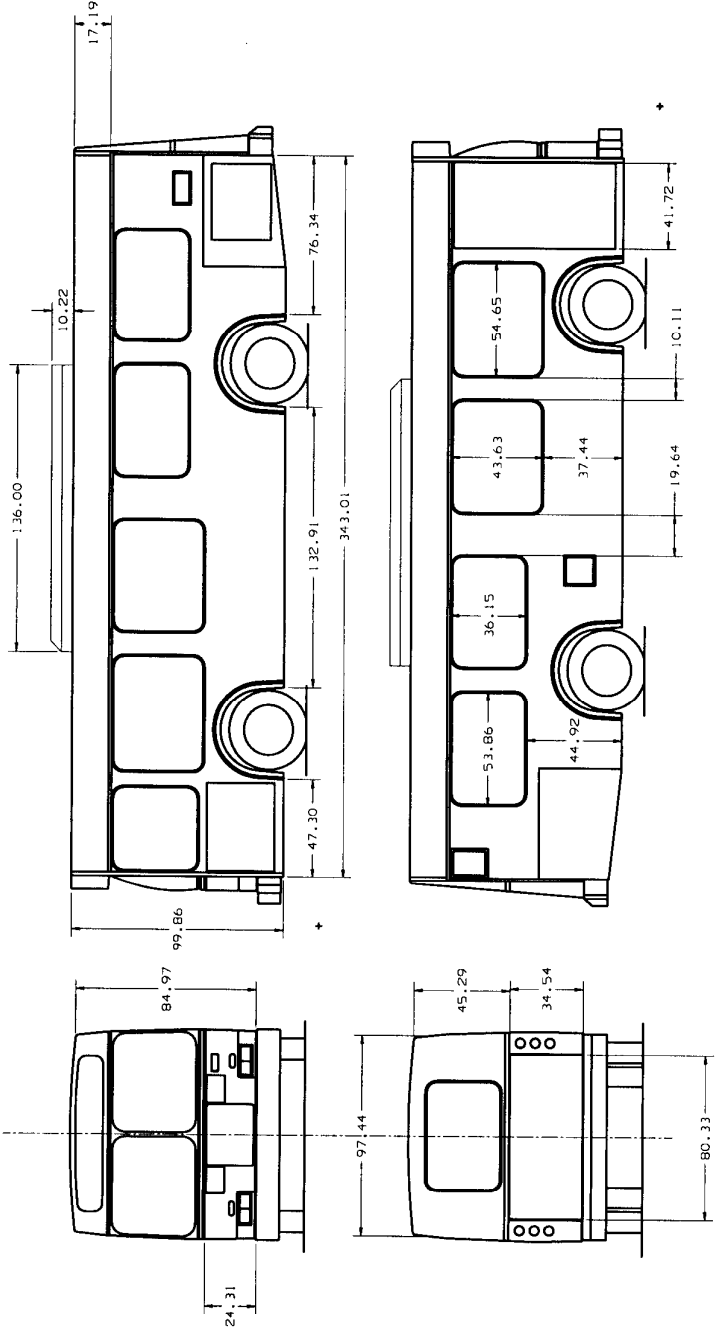

SYMBOL	REVISION	DRAWN	CHECKED	ENG	PR	RELEASE	DATE
<p>ALL LOCATION DIMENSIONS FOR PAINT SCHEME LAYOUT ARE APPROXIMATE AND MAY DIFFER DUE TO STRUCTURAL VARIANCES.</p> <p>NOTICE: THIS DRAWING IS A FACSIMILE OF THE ELECTRONIC MATERIAL. ALL REVISIONS MUST BE MADE TO THE ORIGINAL DRAWING. MANUAL REVISION IS NOT ALLOWED.</p> <p>THIS DRAWING SHOWS PHYSICAL FEATURES STRICTLY PICTORIAL FOR PAINT SCHEME PURPOSES ONLY.</p>							
MATERIAL	REMARKS	TREATMENT	REVISION	BY	NAME	DATE	TITLE
			1				
			2				
			3				
			4				
			5				
			6				
			7				
			8				
			9				
			10				
			11				
			12				
			13				
			14				
			15				
			16				
			17				
			18				
			19				
			20				
			21				
			22				
			23				
			24				
			25				
			26				
			27				
			28				
			29				
			30				
			31				
			32				
			33				
			34				
			35				
			36				
			37				
			38				
			39				
			40				
			41				
			42				
			43				
			44				
			45				
			46				
			47				
			48				
			49				
			50				
			51				
			52				
			53				
			54				
			55				
			56				
			57				
			58				
			59				
			60				
			61				
			62				
			63				
			64				
			65				
			66				
			67				
			68				
			69				
			70				
			71				
			72				
			73				
			74				
			75				
			76				
			77				
			78				
			79				
			80				
			81				
			82				
			83				
			84				
			85				
			86				
			87				
			88				
			89				
			90				
			91				
			92				
			93				
			94				
			95				
			96				
			97				
			98				
			99				
			100				

DESCRIPTION NO. 2

PART NO. **1001**

SCALE **A1**

DATE **11/11/11**

BY **11/11/11**

NAME **11/11/11**

DATE **11/11/11**

TITLE **11/11/11**

THIS DRAWING AND ITS SUBJECT MATTER ARE
 DISCLOSED IN CONFIDENCE AND SHALL NOT BE
 DISCLOSED TO OTHERS WITHOUT WRITTEN
 CONSENT OF NEW FLYER INDUSTRIES LIMITED

0.00
 CTR COACH

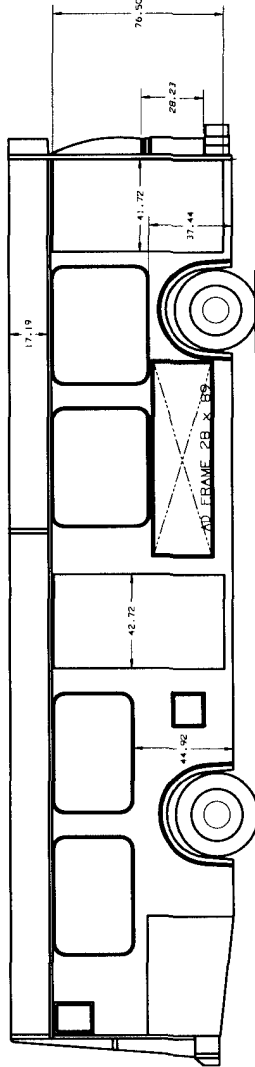
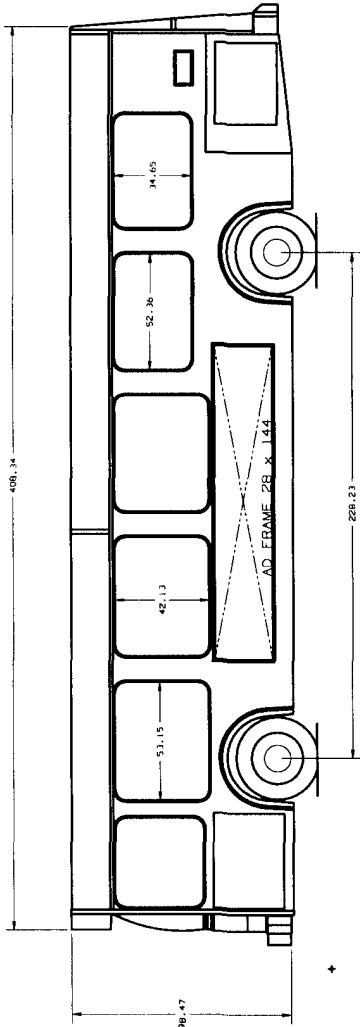
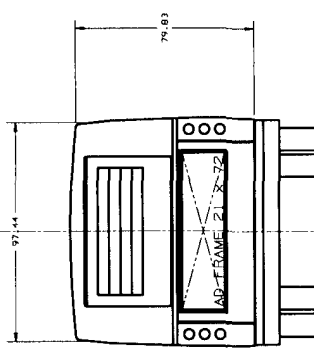
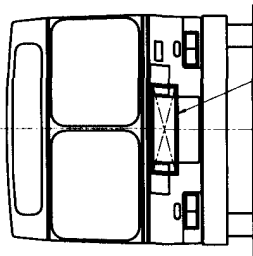

8	7	6	5	4	3	2	1
E	D	C	B	A			
DRAWING NO. RICO PAINT - 035							
TITLE LOW FLOOR - 35 FT							
DATE 31 MAR 99							
DRAWN BY ER 0000							
CHECK'D BY ER 0000							
DATE 31 MAR 99							
SCALE 1:25							
PART NO. RICO PAINT - 035							
SHEET NO. 1							
TOTAL SHEETS 1							
SCALE 1:25							
DRAWN BY ER 0000							
CHECK'D BY ER 0000							
DATE 31 MAR 99							
SCALE 1:25							
PART NO. RICO PAINT - 035							
SHEET NO. 1							
TOTAL SHEETS 1							

NOTICE: THIS DRAWING IS A FACSIMILE OF
 THE ELECTRONIC MASTER. ALL REVISIONS
 MUST BE MADE TO THE MASTER. NO
 MANUAL REVISION IS ALLOWED.

1	RELEASED TO PRODUCTION	3 MAR 99	ER 0000	31 MAR 99
2				
3				
4				
5				
6				
7				
8				

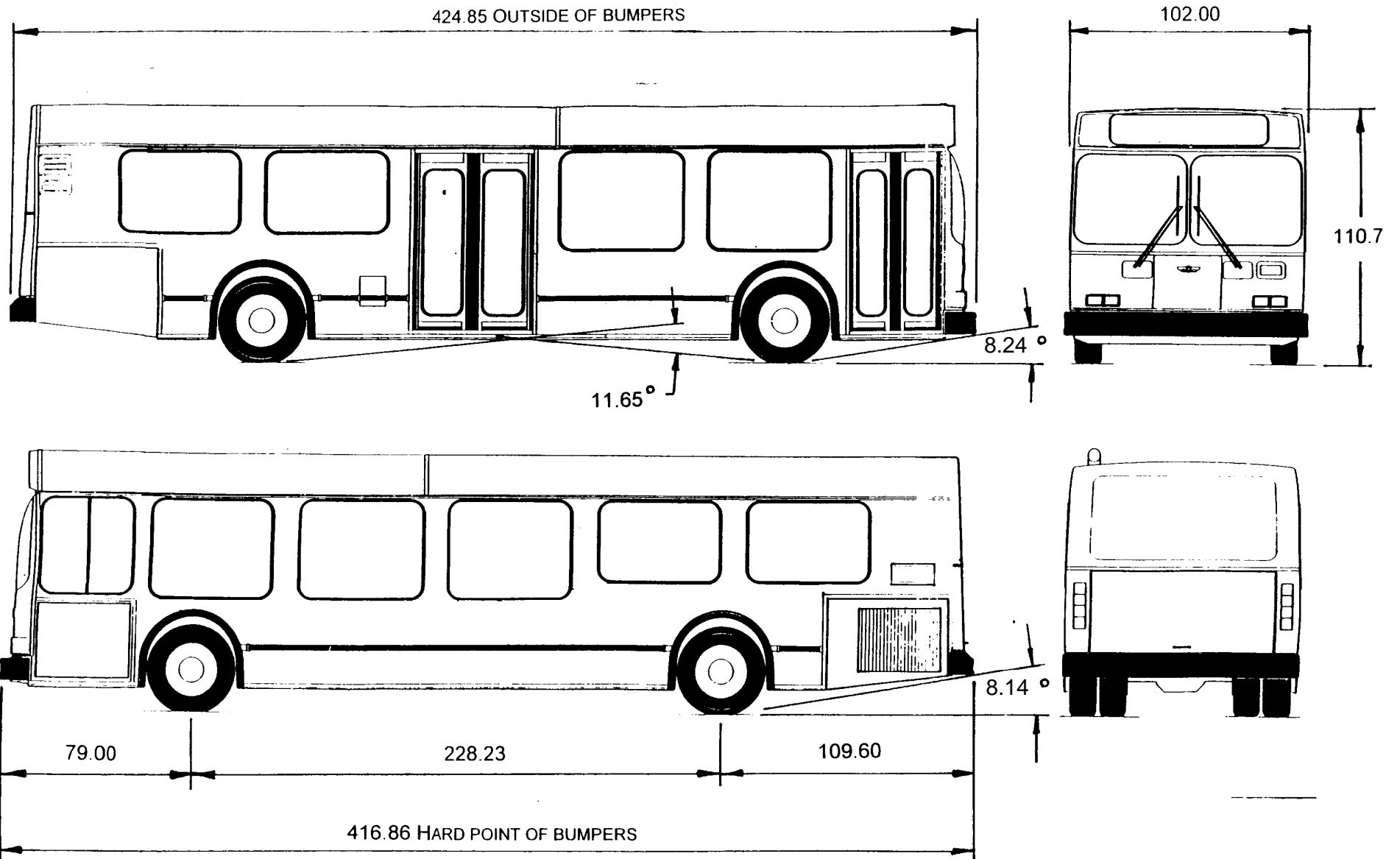

35 FT LOW FLOOR BUS
EXTERIOR DIMENSIONS

THIS DRAWING AND ITS CONTENTS ARE THE PROPERTY OF PETER INCORPORATED. IT IS TO BE USED ONLY FOR THE PURPOSES AND IN THE MANNER SPECIFIED HEREON. IT SHALL NOT BE REPRODUCED, COPIED, EITHER WHOLLY OR IN PART, OR TRANSMITTED IN ANY FORM OR BY ANY MEANS, ELECTRONIC OR MECHANICAL, INCLUDING PHOTOCOPYING, RECORDING, OR BY ANY INFORMATION STORAGE AND RETRIEVAL SYSTEM, WITHOUT THE WRITTEN PERMISSION OF PETER INCORPORATED.

NOTICE: THIS DRAWING IS A PORTION OF A SET OF DRAWINGS. IT SHALL NOT BE USED UNLESS REFERRED TO IN THE MANUFACTURING MANUAL. REVISION IS NOT ALLOWED.

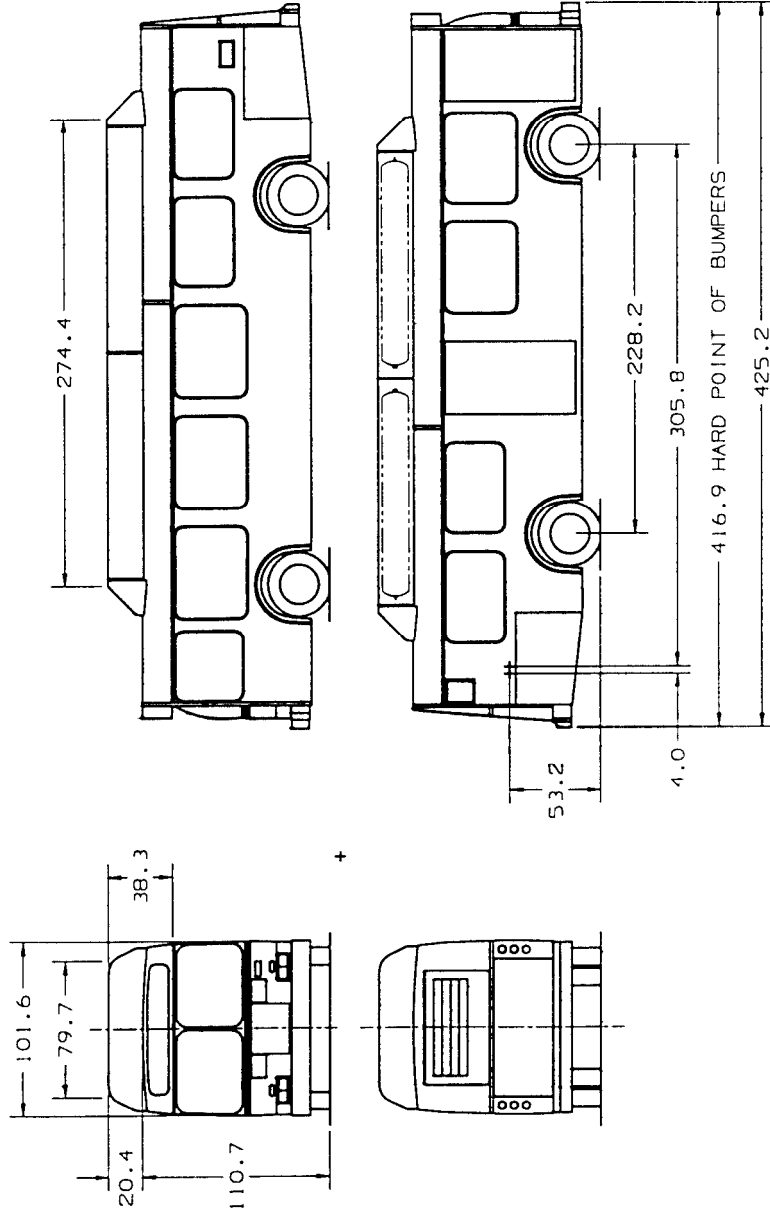

B		REFERENCE ONLY	O.L.R.	06-OCT-97	MATERIAL	UNSPEC'D TOLS:	RED. IN.:	STRIKIO	BY	NAME	DATE	TITLE
SYM		REVISION	DRAWN	CHK'D	ENG'R	WEIGHT	4.12 3.1 2.05 0.3 4.015 0.3 4.03 0.8 4.1	3.1 0.3 0.3 0.8 4.1	DRAWN	G.L.R.	06-OCT-97	35' CNG LOW FLOOR
					TREATMENT	DO NOT SCALE DIMENSIONS IN () ARE IN M.M.	4.20 4.20 4.1X	1X	ENG'R			PART #
						100 LB TO 100 LB PLUS	4.20 4.20 4.1X	1X	THD ANGLE			1135-CNG
												SCALE: 1:50
												SHEET 1 OF 1
												REPORT ALL ERRORS TO ENG. DEPT.

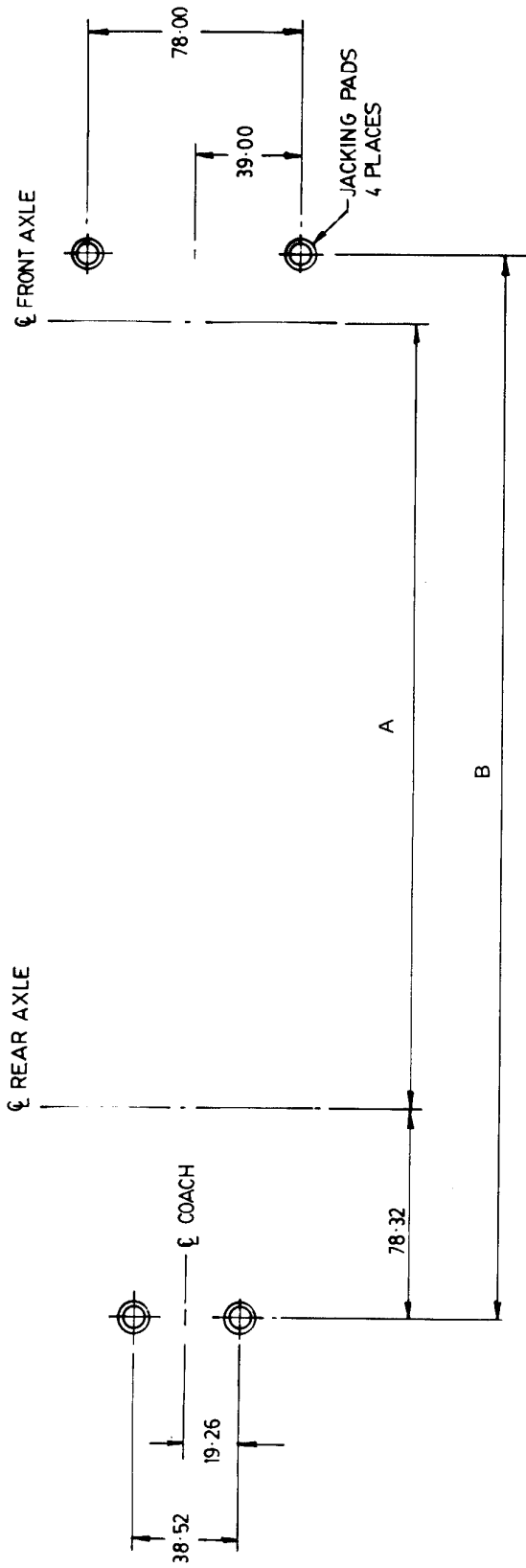

Bus Length	A	B
40 foot	293.00"	397.42"
35 foot	228.23"	332.65"
30 foot	169.08"	273.50"

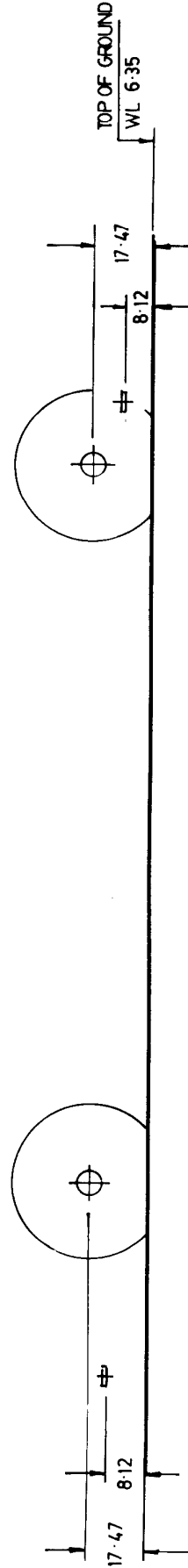

THIS DRAWING AND ITS SPECIFICATIONS ARE DEVELOPED IN COOPERATION WITH THE U.S. GOVERNMENT AND ARE NOT TO BE REPRODUCED OR TRANSMITTED IN ANY FORM OR BY ANY MEANS, ELECTRONIC OR MECHANICAL, INCLUDING PHOTOCOPYING, RECORDING, OR BY ANY INFORMATION STORAGE AND RETRIEVAL SYSTEM, WITHOUT THE WRITTEN PERMISSION OF NEW PLYMER INDUSTRIES LIMITED

NOTICE: THIS DRAWING IS A PART OF THE U.S. GOVERNMENT AND IS NOT TO BE REPRODUCED OR TRANSMITTED IN ANY FORM OR BY ANY MEANS, ELECTRONIC OR MECHANICAL, INCLUDING PHOTOCOPYING, RECORDING, OR BY ANY INFORMATION STORAGE AND RETRIEVAL SYSTEM, WITHOUT THE WRITTEN PERMISSION OF NEW PLYMER INDUSTRIES LIMITED

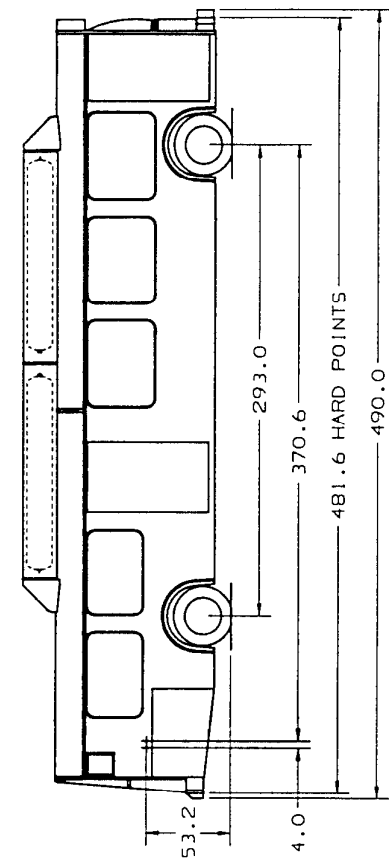
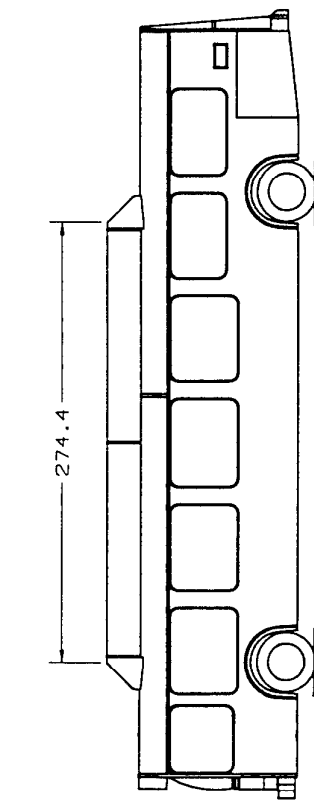
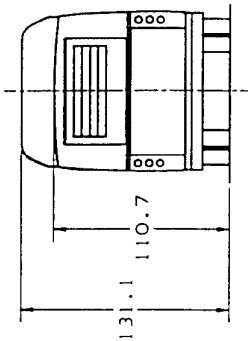
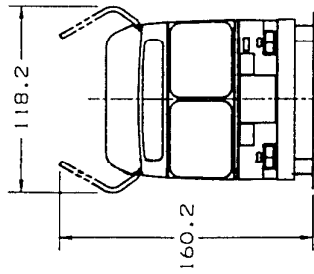

SYN	REVISION	DRAWN/CHK'D/ENG'R	RELEASE	DATE
	5			06-OCT-97

MATERIAL	UNSP'D TOLS.	IND. IN.	METRIC	BY	NAME	DATE	TITLE
	WEIGHT	4.12	3.1	DRAWN	O.L.L.R.	06-OCT-97	40' CNG LOW FLOOR
TREATMENT	4.06	1.5	4.04	CHK'D			
	4.03	0.4	4.03	ENG'R			
	4.20	2.1	4.20				
	4.20	5.1	4.20				
	4.20	5.1	4.20				
	4.1X	1X	4.1X				

SCALE	1 : 50	C
PART N°	1140-CNG	
UNL/CHK'D	UNL/CHK'D	
SHEET	1 OF 1	
REPORT ALL ERRORS TO	ENG. DEPT.	

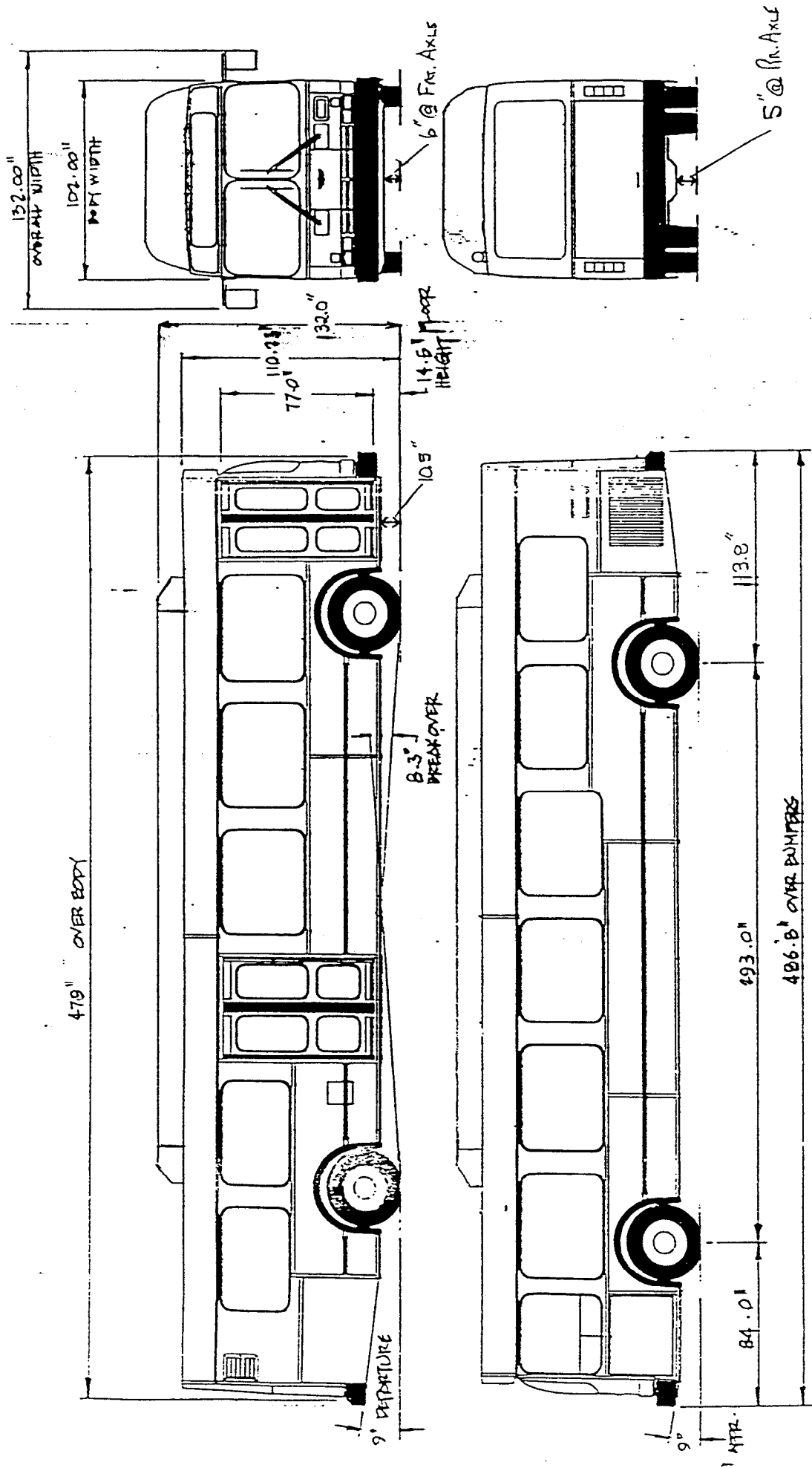

EXTERIOR GENERAL ARRANGEMENT
 MODEL C40LF

THIS DRAWING AND ITS SUBJECT MATTER ARE DEVELOPED IN CONFIDENCE. MUST BE KEPT UNCLASSIFIED AND SHALL NOT BE DISCLOSED TO ANY OTHER PERSON WITHOUT THE CONSENT OF NEW FLYER INDUSTRIES LIMITED

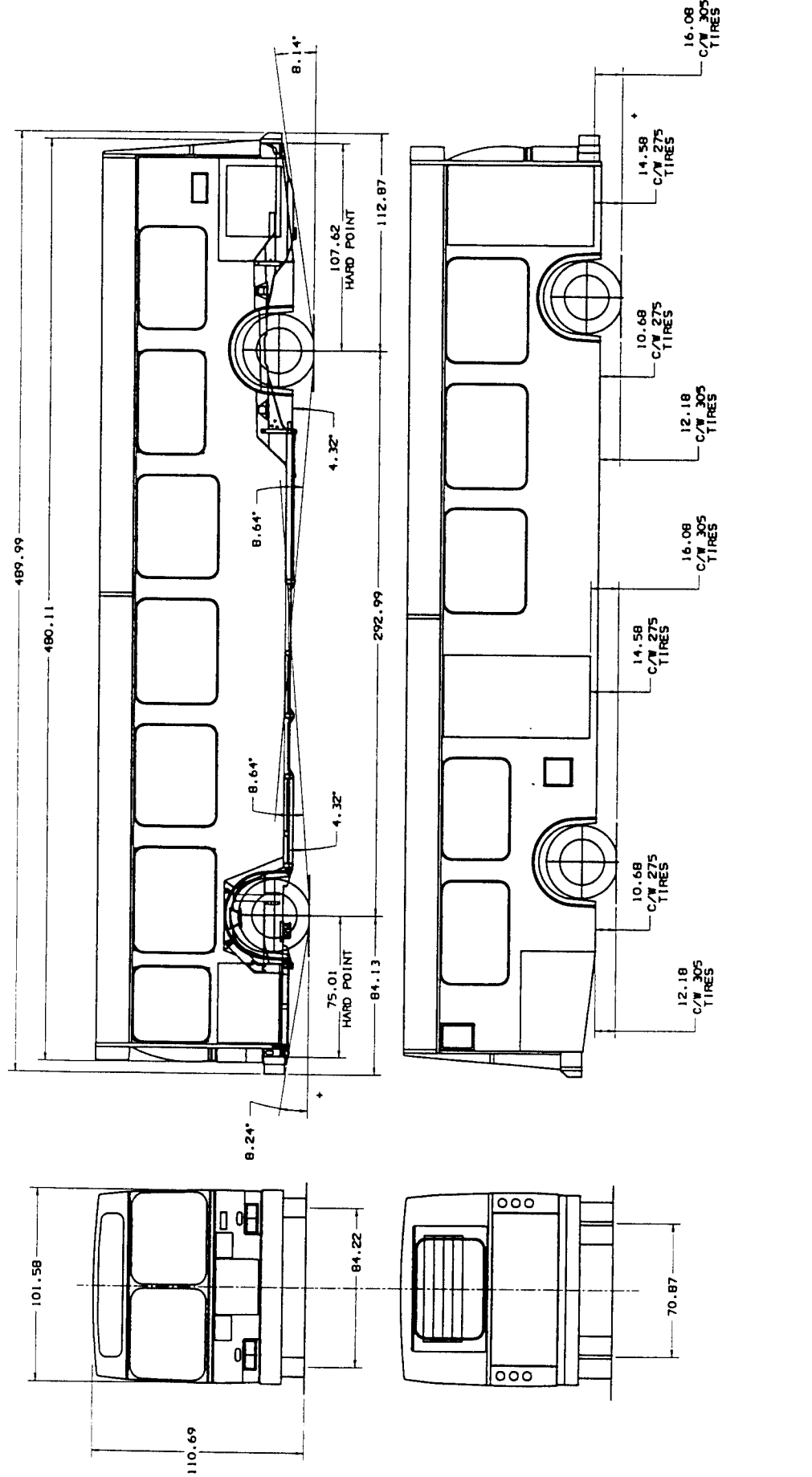

SYM

REVISION

ECO

NOTE: FOR INSTALLATION DRAWINGS PLEASE REFER TO ATTACHED WIP SHEET FOR PARTS LISTING

NOTE: THIS DRAWING IS A SUBSTITUTE OF THE ELECTRICAL WIRING. ALL PARTS MUST BE INCORPORATED ELECTRONICALLY. MANUAL REVISION IS NOT ALLOWED.

MATERIAL
WEIGHT
TREATMENT

REV	DATE	BY	CHK'D	APP'D	QTY	SCALE	DATE
1	31-08-1975					1:1	
2						1:1	
3						1:1	
4						1:1	
5						1:1	
6						1:1	

NO	QTY	DESCRIPTION
1		ML-PAINT-LFB40
2		ML-PAINT-LFB
3		ML-PAINT-LFB

THIS DRAWING AND ITS SUBJECT MATTER ARE DEVELOPED IN CONFIDENCE. ANY REPRODUCTION OR DISCLOSURE TO OTHERS WITHOUT THE WRITTEN CONSENT OF NEUF FLÛTER INDUSTRIES LIMITED.

0.00
CTR COACH

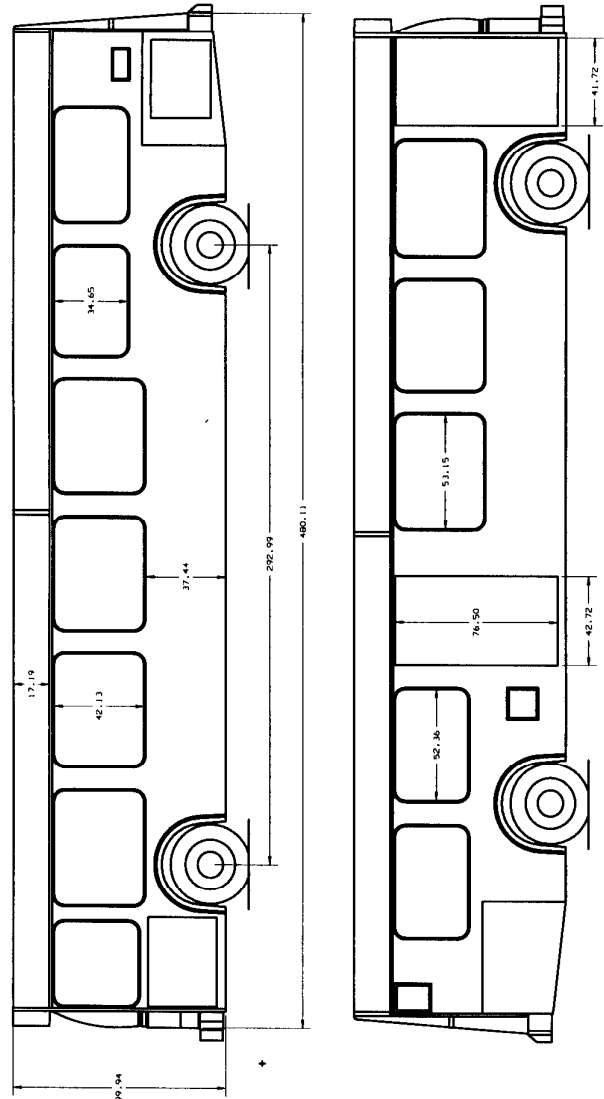
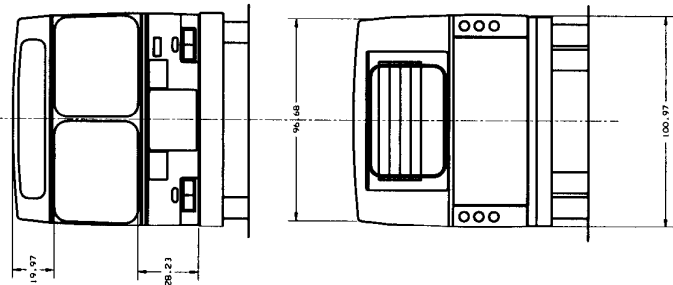

8 7 6 5 4 3 2 1

E D C B A

DRAWING NO. R-CPAINT-11FB

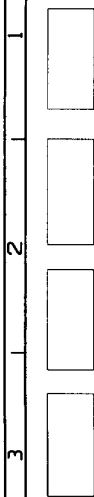

REV	0000	31-MAR-95
DRWNG	CHK'D	ENG'R
REVISION	RELEASE	DATE

ALL LOCATION DIMENSIONS FOR PAINT SCHEME LAYOUT ARE APPROXIMATE AND MAY DIFFER DUE TO STRUCTURAL VARIANCES.
THIS DRAWING SHOWS PHYSICAL FEATURES STRICTLY FOR PAINT SCHEME PURPOSES ONLY.
NOTICE: THIS DRAWING IS A FACSIMILE OF ORIGINAL DRAWING & MUST BE INCORPORATED ELECTRONICALLY. MANUAL REVISION IS NOT ALLOWED.

MATERIAL	NET WT	TREATMENT
<p>UNLESS OTHERWISE SPECIFIED, ALL DIMENSIONS ARE IN MILLIMETERS UNLESS OTHERWISE SPECIFIED.</p> <p>ALL DIMENSIONS ARE TO CENTER UNLESS OTHERWISE SPECIFIED.</p> <p>ALL DIMENSIONS ARE TO FACE UNLESS OTHERWISE SPECIFIED.</p> <p>ALL DIMENSIONS ARE TO CENTER UNLESS OTHERWISE SPECIFIED.</p> <p>ALL DIMENSIONS ARE TO FACE UNLESS OTHERWISE SPECIFIED.</p>		
BY	DATE	TITLE
DRWNG	31-MAR-95	LOW FLOOR - EXTERIOR
CHK'D		
ENG'R		
DO NOT SCALE	SCALE	PART NO
FOR DIMENSIONS	1:1	R-CPAINT-11FB
USE THIS ANGLE	1:1	REVISION
		REPORT ALL REVISIONS TO ENG. DEPT.

THIS DRAWING AND ITS SUBJECT MATTER ARE
 DISCLOSED IN CONFIDENCE AND MUST BE
 RETURNED TO THE DRAWING OFFICE AND NOT BE
 REPRODUCED OR COPIED IN ANY MANNER
 WITHOUT THE WRITTEN CONSENT OF NEW FLUOR
 INDUSTRIES LIMITED

DRAWING NO
 050104

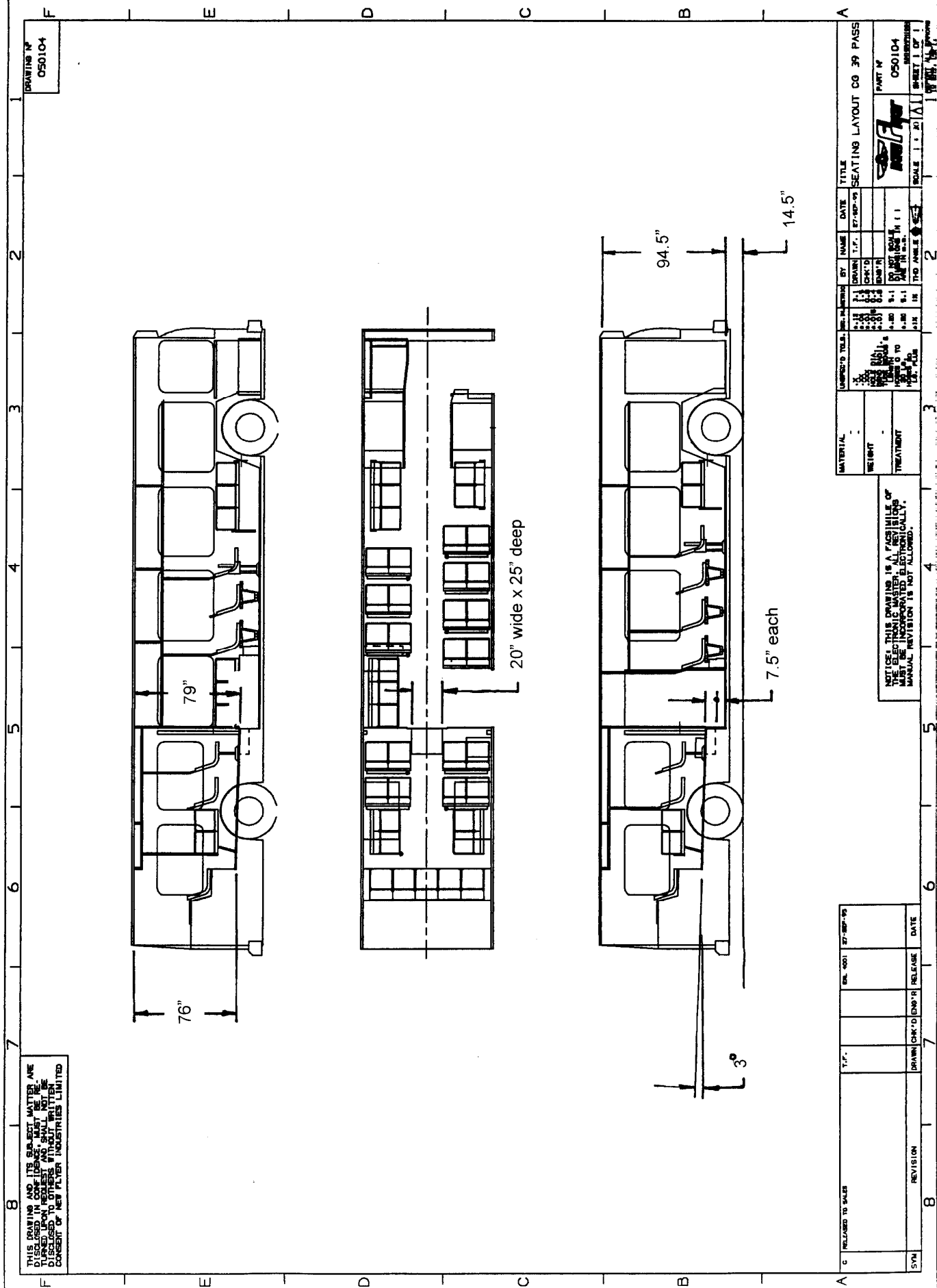

REL. TO SALES	T.F.	ENL. NO.1	27-SEP-75	DATE
REVISION	DRAWN	CHK'D	ENGR	RELEASE
SYM.	REV.	CHK'D	ENGR	RELEASE

MATERIAL	UNLESS STATED OTHERWISE	BY	NAME	DATE	TITLE
WEIGHT	1.1	DRAWN	T.F.	27-SEP-75	SEATING LAYOUT CO 39 PASS
TREATMENT	1.1	CHK'D			
	1.1	ENGR			
	1.1	CHK'D			
	1.1	ENGR			
	1.1	CHK'D			
	1.1	ENGR			
	1.1	CHK'D			
	1.1	ENGR			
	1.1	CHK'D			
	1.1	ENGR			

NOTICE: THIS DRAWING IS A FACSIMILE OF
 THE ELECTRONIC MASTER. ALL REVISIONS
 MUST BE INCORPORATED ELECTRONICALLY.
 MANUAL REVISION IS NOT ALLOWED.

PART NO
 050104
 SUBSEQUENT
 SHEET 1 OF 1
 SCALE 1:1

THIS DRAWING AND ITS SUBJECT MATTER ARE
 DISCLOSED IN CONFIDENCE. ANY RE-
 DISCLOSURE TO OTHERS WITHOUT WRITTEN
 CONSENT OF NEW FLYER INDUSTRIES LIMITED

DRAWING NO
 050104

A = 3
 B = 7.5"
 C = 14.5"
 D = 20"
 E = 25"

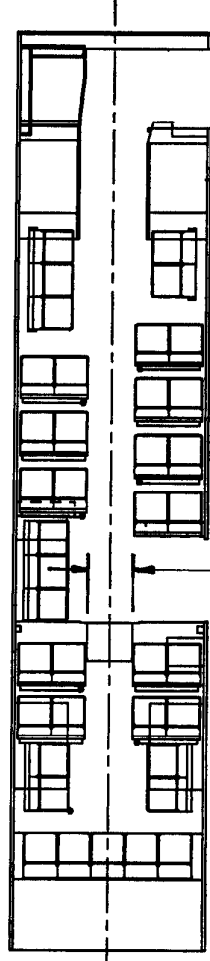
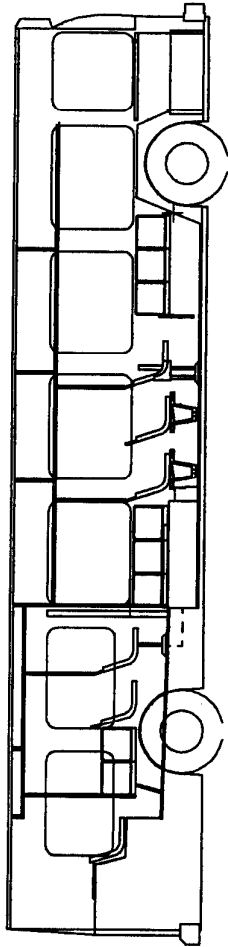

D wide x E deep

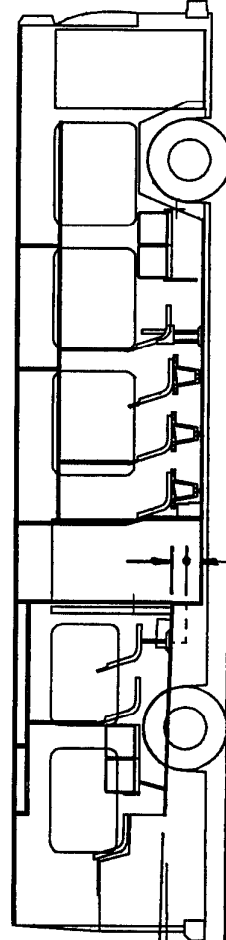

SYN	REVISION	DRAWN (CHK'D)	EMP'N	RELEASE	DATE

REL. 4001 27-SEP-95

NOTICE: THIS DRAWING IS A FACSIMILE OF
 THE ELECTRONIC MASTER. ALL REVISIONS OF
 THIS DRAWING MUST BE MADE TO THE
 MANUAL. REVISIONS IN THE FACSIMILE
 ARE NOT ALLOWED.

MATERIAL
 WEIGHT
 TREATMENT

UNLESS OTHERWISE SPECIFIED	BY	NAME	DATE
DESIGN	T.P.	T.P.	27-SEP-95
CHK'D	EMP'N	EMP'N	
EMP'N	EMP'N	EMP'N	
IN	IN	IN	
IN	IN	IN	
IN	IN	IN	
IN	IN	IN	

PART NO



SCALE 1:1

TRD ANGLE

2

2

2

2

2

2

2

2

2

2

2

2

2

2

2

2

2

2

2

2

2

2

2

2

2

2

2

2

2

2

2

2

2

2

2

2

2

2

2

2

2

2

2

2

2

2

2

2

2

2

2

2

2

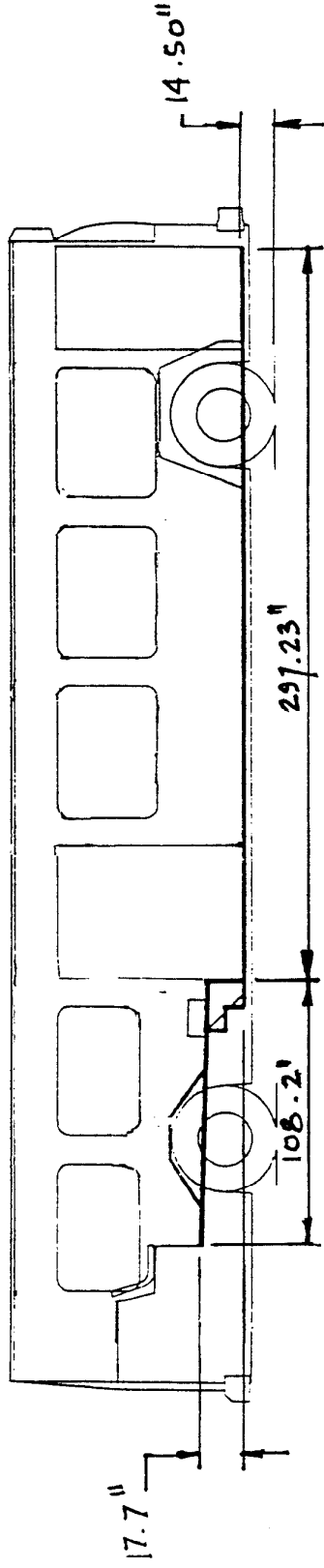
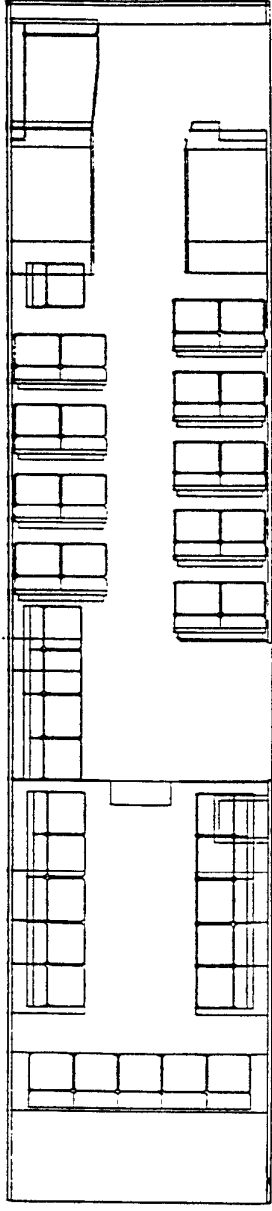
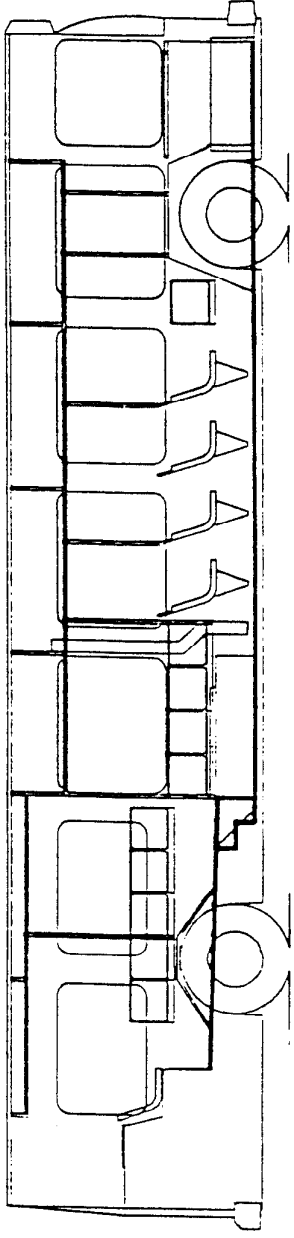

 **new Flyer**

D40LF Low Floor Bus

DRAWING NO
050104

2

3

4

5

6

7

8

THIS DRAWING AND ITS SUBJECT MATTER ARE
DISCLOSED TO THE PUBLIC AND SHALL NOT BE
TURNED OVER TO THE GOVERNMENT WITHOUT WRITTEN
CONSENT OF NEW PATER INDUSTRIES LIMITED

- A = 3
- B = 7.5"
- C = 14.5"
- D = 20"
- E = 25"

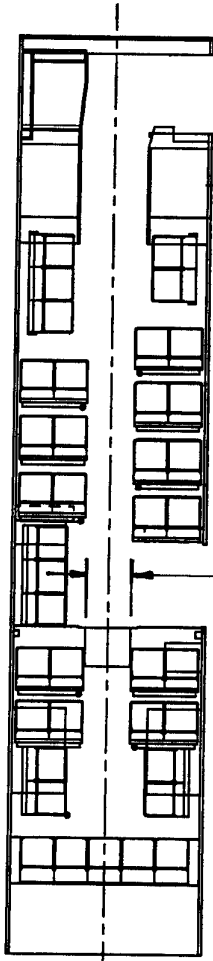
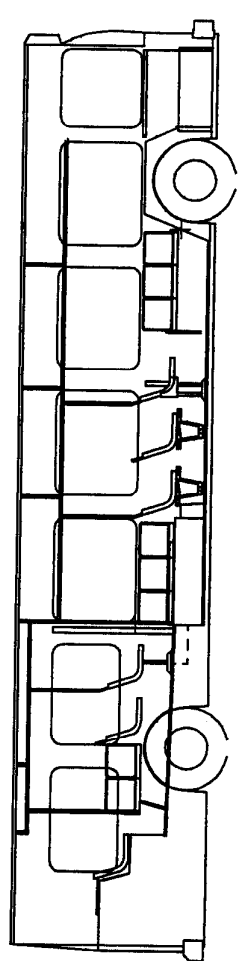

D wide x E deep

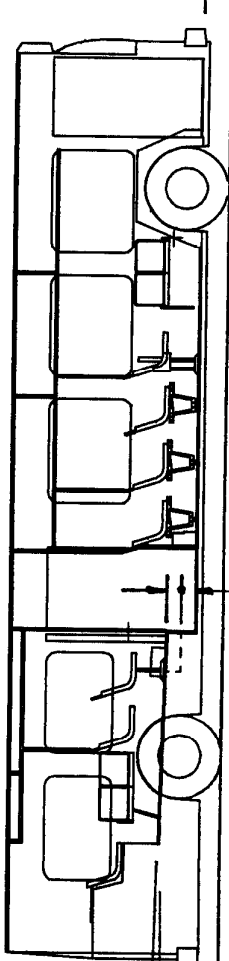

C

B

A

SYMBOL	REVISION	DRAWN (S&T)	RELEASE	DATE

UNDESIGNED TOLS.	DESIGNER	BY	NAME	DATE
1	1	1	1	27-SEP-59
2	2	2	2	
3	3	3	3	
4	4	4	4	
5	5	5	5	
6	6	6	6	
7	7	7	7	
8	8	8	8	
9	9	9	9	
10	10	10	10	
11	11	11	11	
12	12	12	12	
13	13	13	13	
14	14	14	14	
15	15	15	15	
16	16	16	16	
17	17	17	17	
18	18	18	18	
19	19	19	19	
20	20	20	20	
21	21	21	21	
22	22	22	22	
23	23	23	23	
24	24	24	24	
25	25	25	25	
26	26	26	26	
27	27	27	27	
28	28	28	28	
29	29	29	29	
30	30	30	30	
31	31	31	31	
32	32	32	32	
33	33	33	33	
34	34	34	34	
35	35	35	35	
36	36	36	36	
37	37	37	37	
38	38	38	38	
39	39	39	39	
40	40	40	40	
41	41	41	41	
42	42	42	42	
43	43	43	43	
44	44	44	44	
45	45	45	45	
46	46	46	46	
47	47	47	47	
48	48	48	48	
49	49	49	49	
50	50	50	50	
51	51	51	51	
52	52	52	52	
53	53	53	53	
54	54	54	54	
55	55	55	55	
56	56	56	56	
57	57	57	57	
58	58	58	58	
59	59	59	59	
60	60	60	60	
61	61	61	61	
62	62	62	62	
63	63	63	63	
64	64	64	64	
65	65	65	65	
66	66	66	66	
67	67	67	67	
68	68	68	68	
69	69	69	69	
70	70	70	70	
71	71	71	71	
72	72	72	72	
73	73	73	73	
74	74	74	74	
75	75	75	75	
76	76	76	76	
77	77	77	77	
78	78	78	78	
79	79	79	79	
80	80	80	80	
81	81	81	81	
82	82	82	82	
83	83	83	83	
84	84	84	84	
85	85	85	85	
86	86	86	86	
87	87	87	87	
88	88	88	88	
89	89	89	89	
90	90	90	90	
91	91	91	91	
92	92	92	92	
93	93	93	93	
94	94	94	94	
95	95	95	95	
96	96	96	96	
97	97	97	97	
98	98	98	98	
99	99	99	99	
100	100	100	100	

NOTICE: THIS DRAWING IS A PART OF THE
ELECTRONICALLY STORED INFORMATION SYSTEM
AND IS SUBJECT TO THE PROVISIONS OF THE
AUTOMATIC DECLASSIFICATION GUIDE
MATERIAL RELEASE IS NOT ALLOWED



SCALE 1:20 (A)
PART NO
SHEET 1 OF 1

2

3

4

5

6

7

8

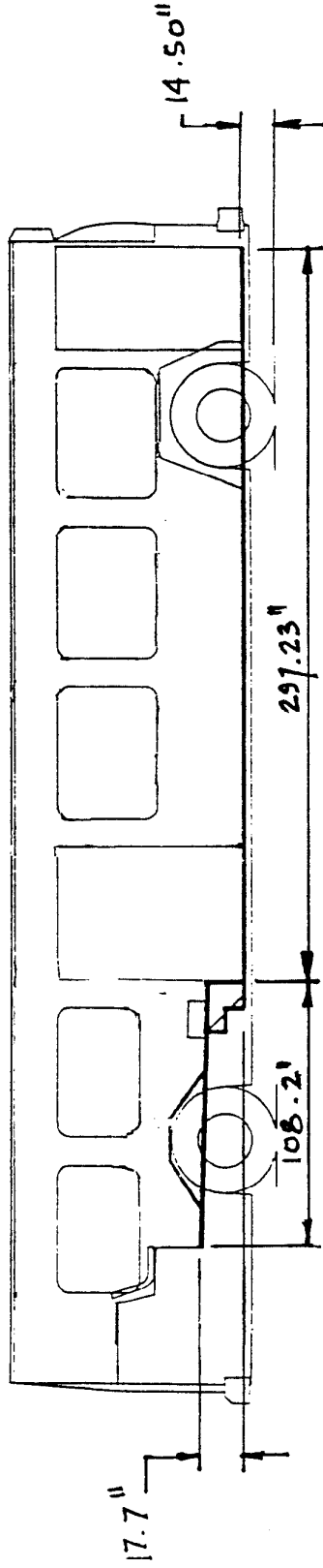
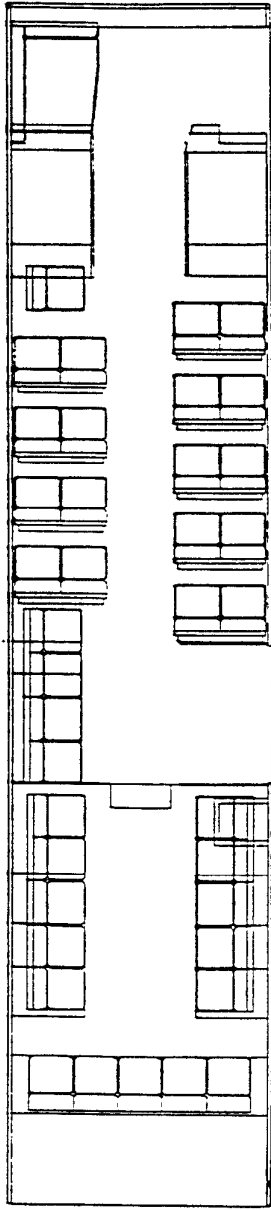
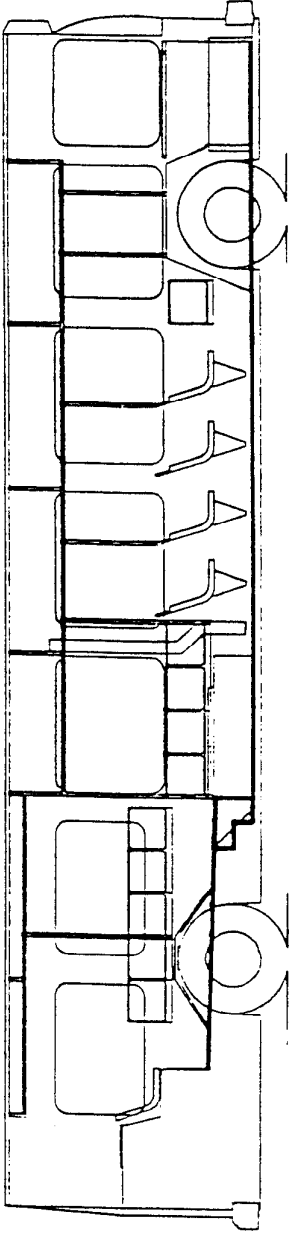

D40LF Low Floor Bus

DRAWING NO
050104

2

3

4

5

6

7

8

THIS DRAWING AND ITS SUBJECT MATTER ARE
DISCLOSED TO THE PUBLIC AND SHALL NOT BE
TURNED OVER TO ANY OTHER PARTY WITHOUT WRITTEN
CONSENT OF NEW PATER INDUSTRIES LIMITED

- A = 3
- B = 7.5"
- C = 14.5"
- D = 20"
- E = 25"

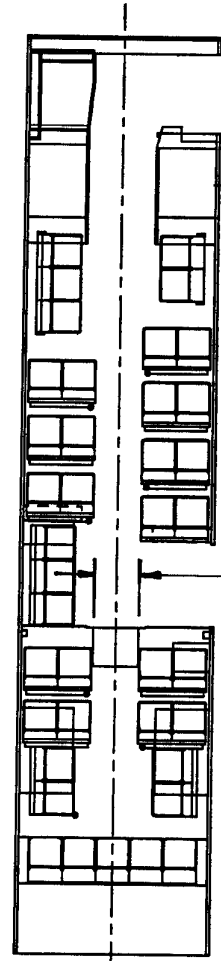
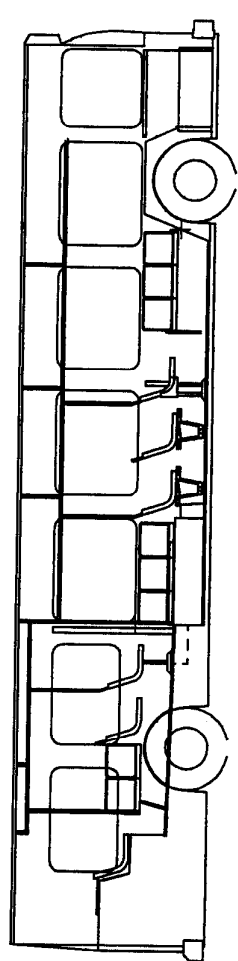

D wide x E deep

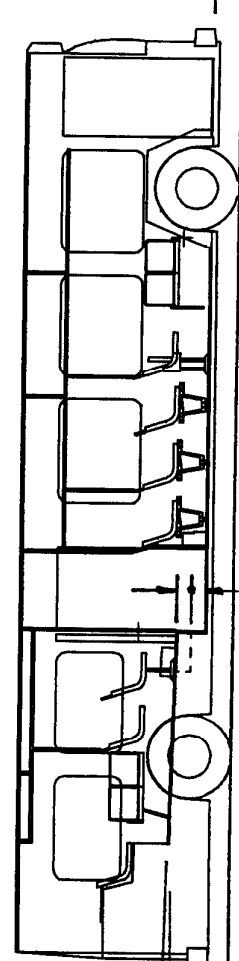

SYMBOL	REVISION	DRAWN (S&P)	RELEASE	DATE

UNLISHED TOLS.	NO. IN STOCK	BY	NAME	DATE
1	1	DR	T.P.	27-SEP-69
2	1	DR	T.P.	
3	1	DR	T.P.	
4	1	DR	T.P.	
5	1	DR	T.P.	
6	1	DR	T.P.	
7	1	DR	T.P.	
8	1	DR	T.P.	
9	1	DR	T.P.	
10	1	DR	T.P.	
11	1	DR	T.P.	
12	1	DR	T.P.	
13	1	DR	T.P.	
14	1	DR	T.P.	
15	1	DR	T.P.	
16	1	DR	T.P.	
17	1	DR	T.P.	
18	1	DR	T.P.	
19	1	DR	T.P.	
20	1	DR	T.P.	
21	1	DR	T.P.	
22	1	DR	T.P.	
23	1	DR	T.P.	
24	1	DR	T.P.	
25	1	DR	T.P.	
26	1	DR	T.P.	
27	1	DR	T.P.	
28	1	DR	T.P.	
29	1	DR	T.P.	
30	1	DR	T.P.	
31	1	DR	T.P.	
32	1	DR	T.P.	
33	1	DR	T.P.	
34	1	DR	T.P.	
35	1	DR	T.P.	
36	1	DR	T.P.	
37	1	DR	T.P.	
38	1	DR	T.P.	
39	1	DR	T.P.	
40	1	DR	T.P.	
41	1	DR	T.P.	
42	1	DR	T.P.	
43	1	DR	T.P.	
44	1	DR	T.P.	
45	1	DR	T.P.	
46	1	DR	T.P.	
47	1	DR	T.P.	
48	1	DR	T.P.	
49	1	DR	T.P.	
50	1	DR	T.P.	
51	1	DR	T.P.	
52	1	DR	T.P.	
53	1	DR	T.P.	
54	1	DR	T.P.	
55	1	DR	T.P.	
56	1	DR	T.P.	
57	1	DR	T.P.	
58	1	DR	T.P.	
59	1	DR	T.P.	
60	1	DR	T.P.	
61	1	DR	T.P.	
62	1	DR	T.P.	
63	1	DR	T.P.	
64	1	DR	T.P.	
65	1	DR	T.P.	
66	1	DR	T.P.	
67	1	DR	T.P.	
68	1	DR	T.P.	
69	1	DR	T.P.	
70	1	DR	T.P.	
71	1	DR	T.P.	
72	1	DR	T.P.	
73	1	DR	T.P.	
74	1	DR	T.P.	
75	1	DR	T.P.	
76	1	DR	T.P.	
77	1	DR	T.P.	
78	1	DR	T.P.	
79	1	DR	T.P.	
80	1	DR	T.P.	
81	1	DR	T.P.	
82	1	DR	T.P.	
83	1	DR	T.P.	
84	1	DR	T.P.	
85	1	DR	T.P.	
86	1	DR	T.P.	
87	1	DR	T.P.	
88	1	DR	T.P.	
89	1	DR	T.P.	
90	1	DR	T.P.	
91	1	DR	T.P.	
92	1	DR	T.P.	
93	1	DR	T.P.	
94	1	DR	T.P.	
95	1	DR	T.P.	
96	1	DR	T.P.	
97	1	DR	T.P.	
98	1	DR	T.P.	
99	1	DR	T.P.	
100	1	DR	T.P.	

NOTICE: THIS DRAWING IS A PART OF THE
ELECTRONICALLY STORED INFORMATION SYSTEM
AND IS NOT TO BE REPRODUCED OR TRANSMITTED
IN ANY FORM OR BY ANY MEANS, ELECTRONICALLY
OR MECHANICALLY, INCLUDING PHOTOCOPYING,
RECORDING, OR BY ANY INFORMATION STORAGE
AND RETRIEVAL SYSTEM, WITHOUT PERMISSION
IN WRITING FROM NEW PATER INDUSTRIES LIMITED.

SCALE 1:10
PART NO
SHEET 1 OF 1

2

3

4

5

6

7

8

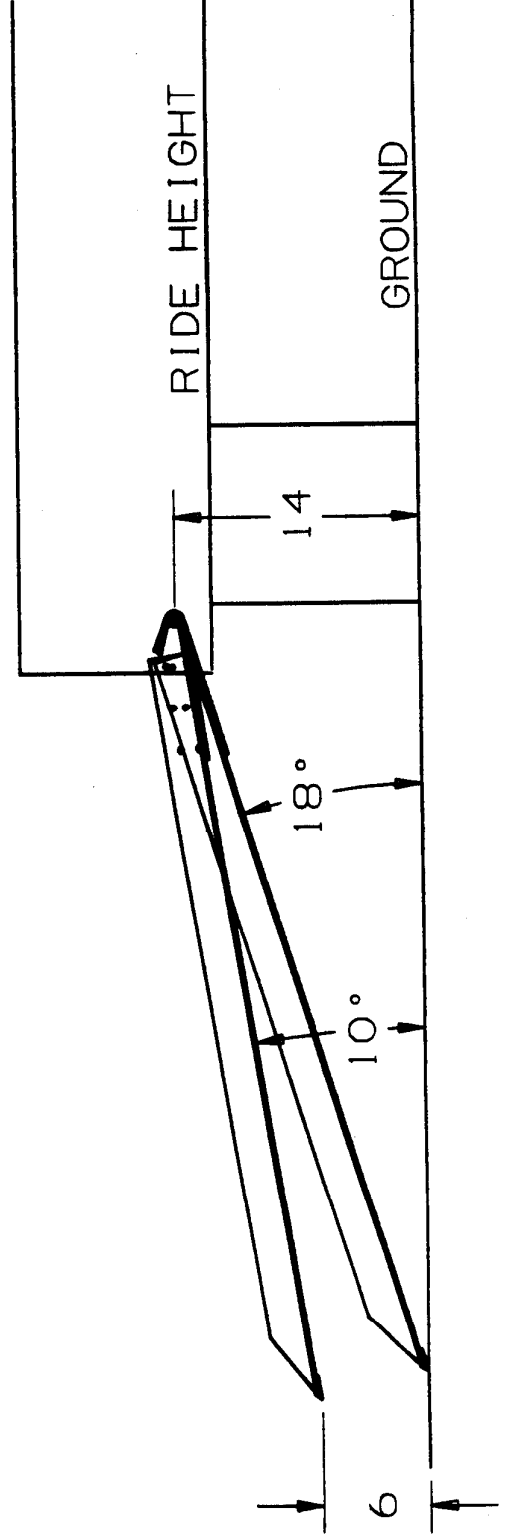
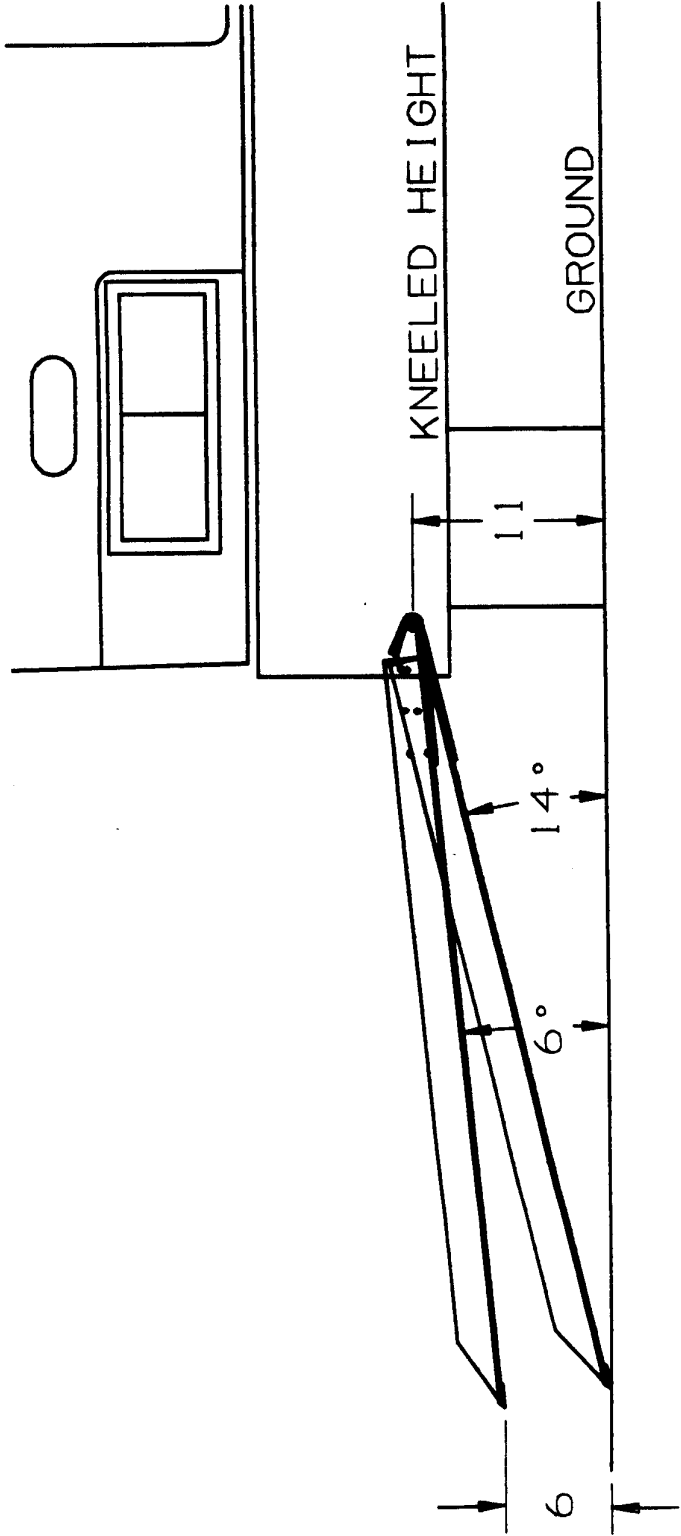

THIS DRAWING AND ITS DIMENSIONS ARE TO BE USED IN CONNECTION WITH THE SPECIFICATIONS AND CONDITIONS OF CONTRACT AND NOT APPLIED TO OTHER TYPES OF VEHICLES OR TO OTHER TYPES OF USE.

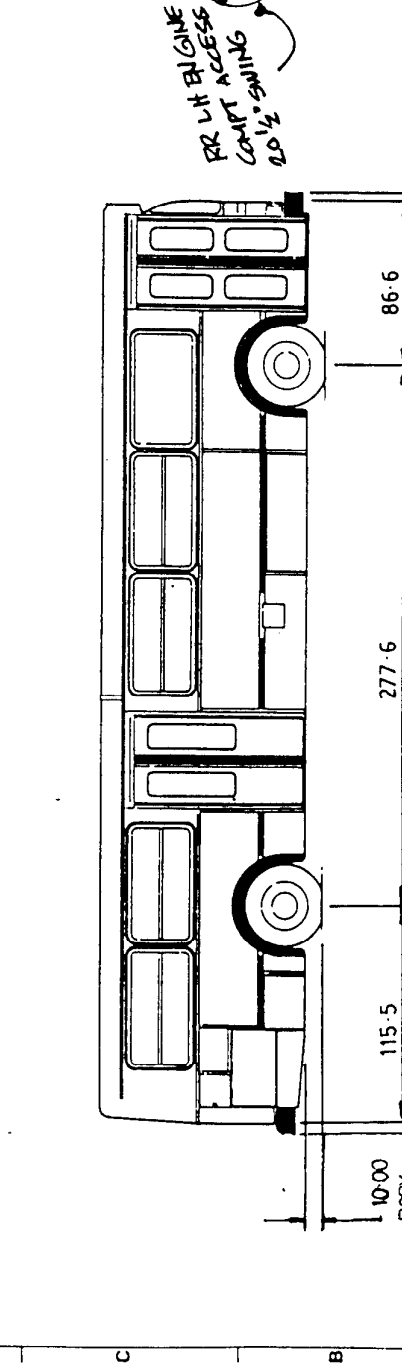
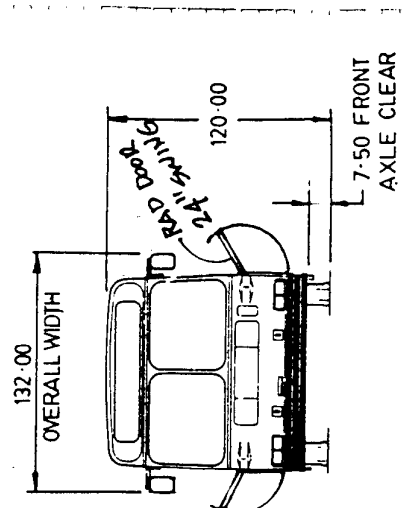
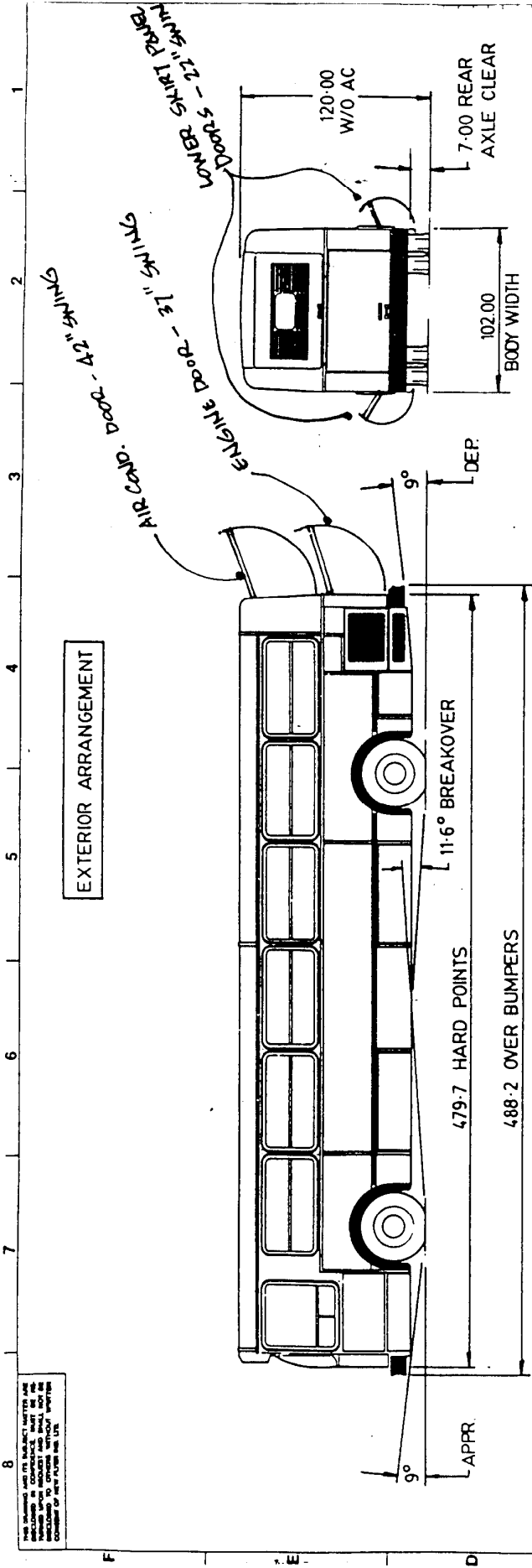

CITY	QUANTITY	PART NO.	DESCRIPTION	UNIT	DATE	SCALE

BY	DATE	TITLE
DRWING	5-8-64	40 FT HF T-DR
CHK'D		
ENG'D		
DESIGNED BY		
DATE IN CHG.		
PROJECT NO.		

MATERIAL	TREATMENT	WEIGHT

ITEM	QTY	UNIT	WEIGHT

DATE	BY	CHK'D	ENG'D	APP'D	DATE

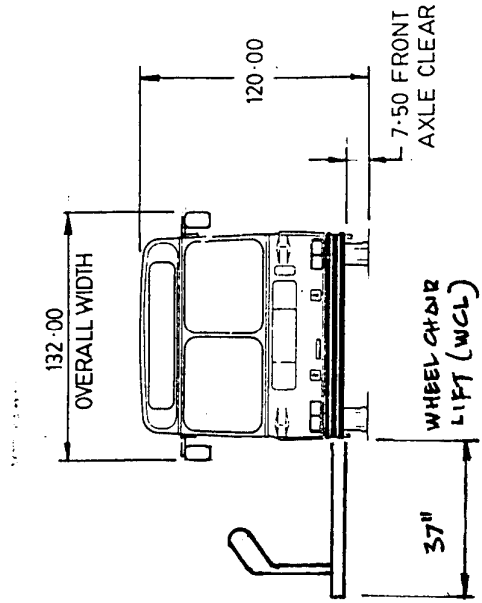

FRONT VIEW

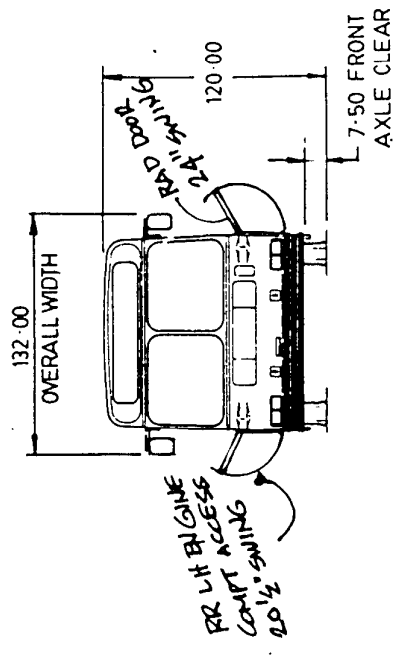

FRONT VIEW

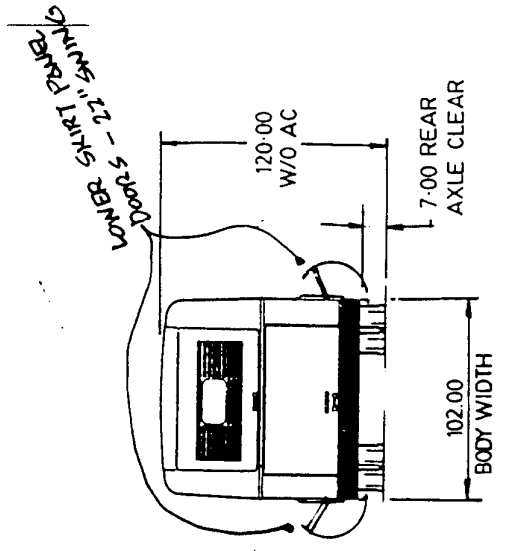

REAR VIEW

L/H SIDE

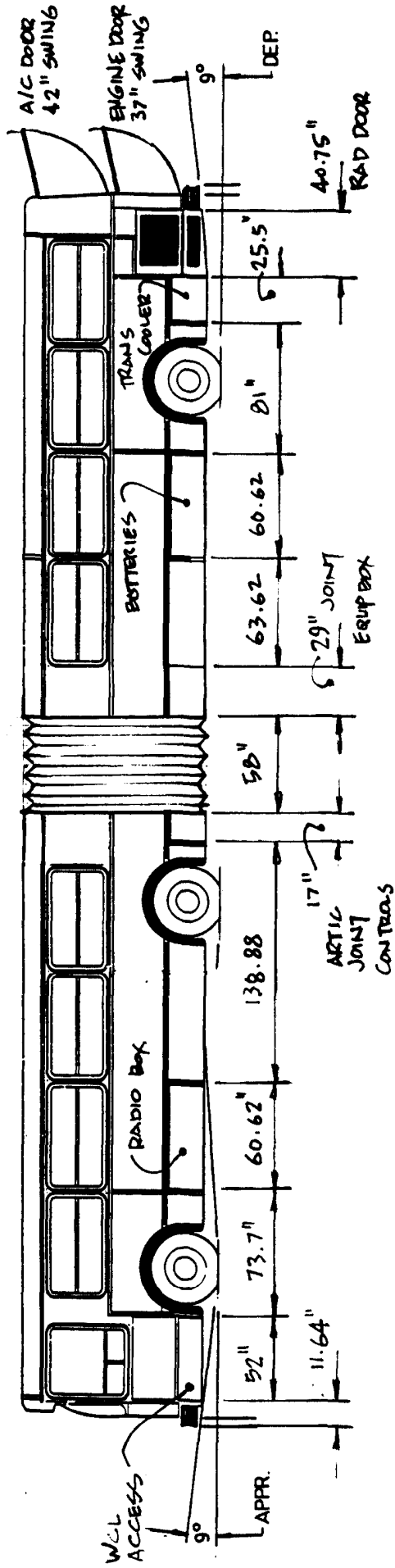

R/H SIDE

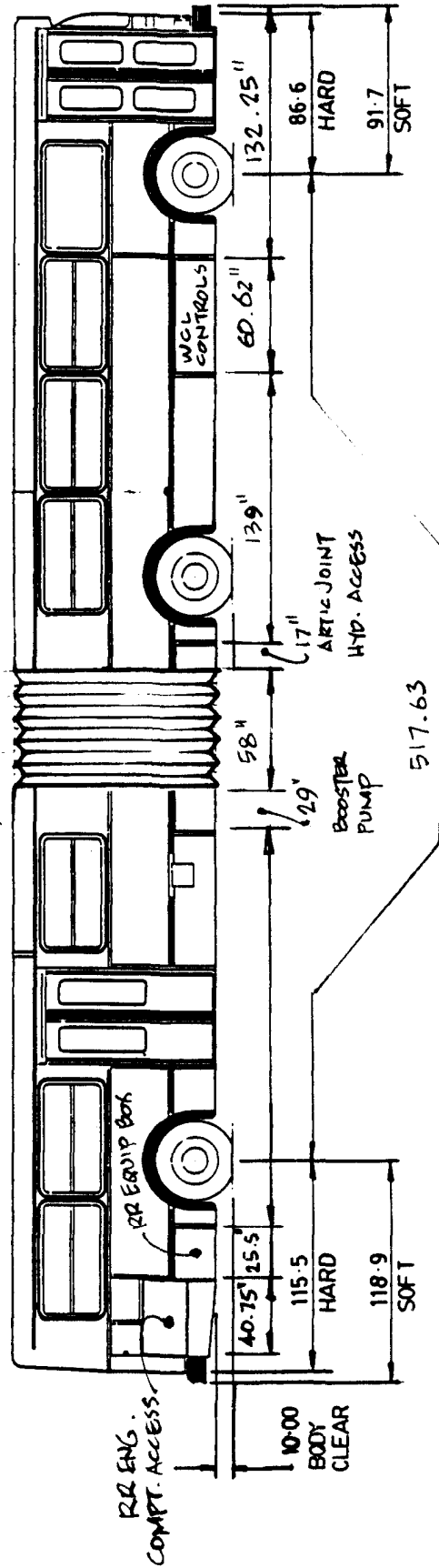

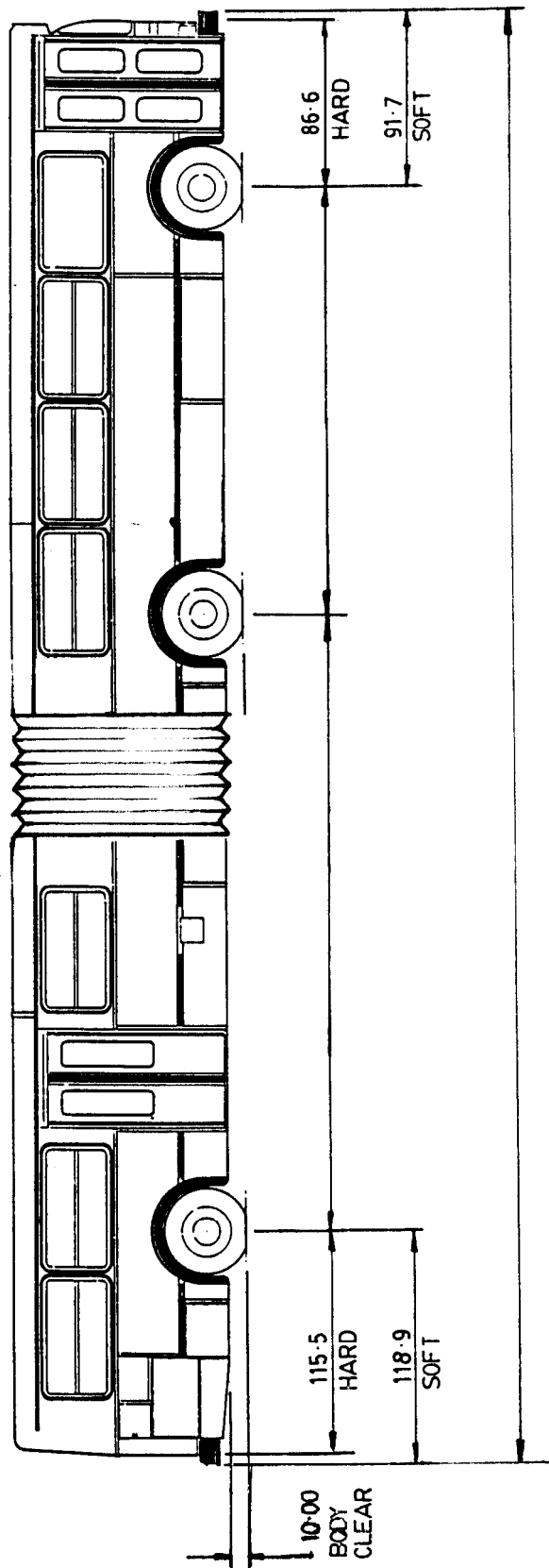
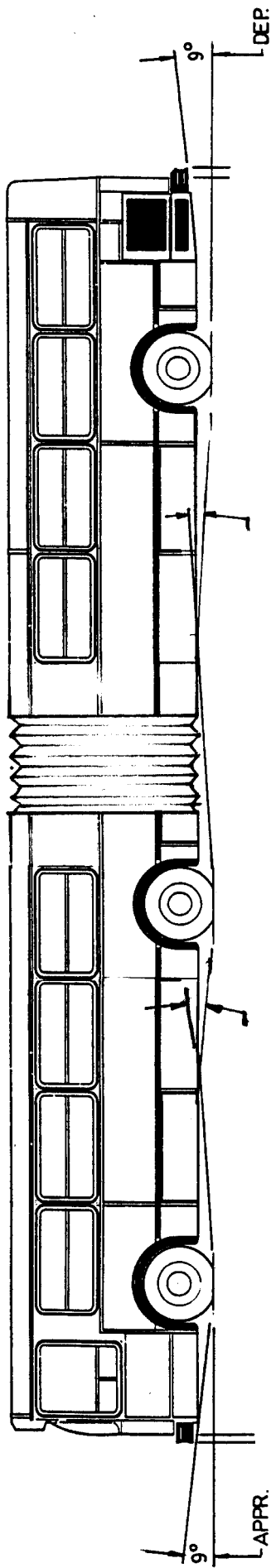

10 9 8 7 6 5 4 3 2

H G F E D C B A

THIS DRAWING AND ITS CONTENTS ARE UNCLASSIFIED AND PUBLIC RELEASE IS AUTHORIZED BY THE NATIONAL ARCHIVES

ROUTINE # D60LFB

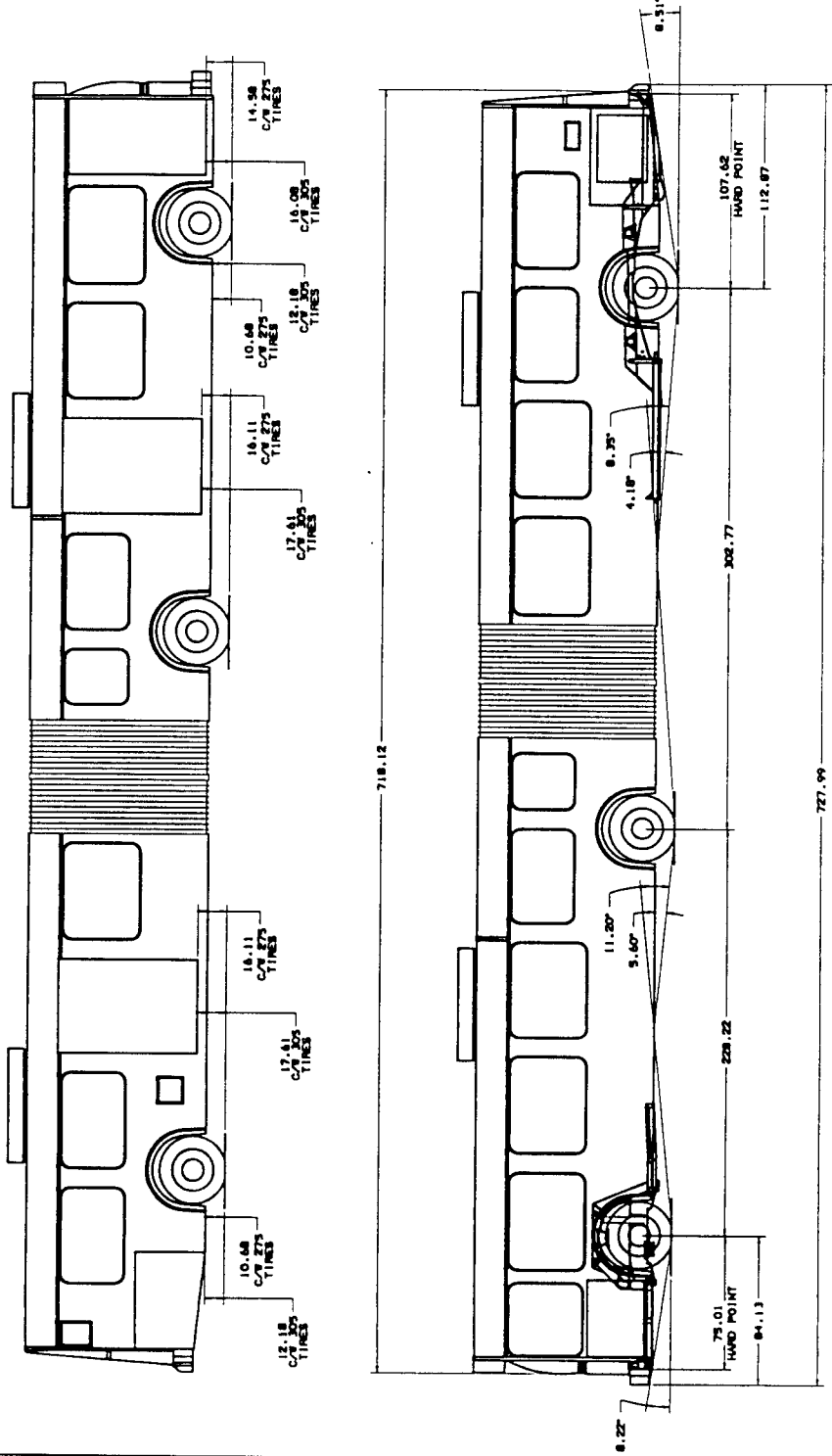

REV	REVISION	DATE	BY	CHKD	DATE	TITLE
1						D60LFB
2						D60LFB
3						D60LFB
4						D60LFB
5						D60LFB
6						D60LFB
7						D60LFB
8						D60LFB
9						D60LFB
10						D60LFB

NOTED: THIS DRAWING IS A COPY OF THE ORIGINAL DRAWING AND IS NOT TO BE USED FOR CONSTRUCTION PURPOSES.

60 FOOT LOW FLOOR
ARTICULATED BUS DIMENSIONS

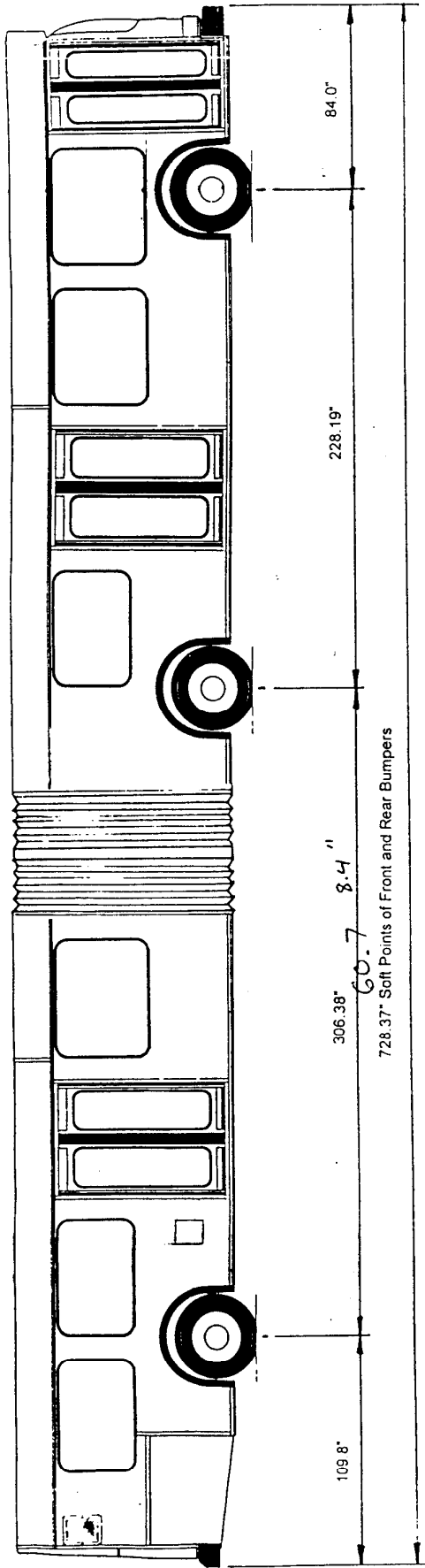

Road Clearance Angles

- 9 deg. Approach
- 10 1/2 deg. Breakover Front Section
- 8 deg. Breakover Rear Section
- 9 deg. Departure

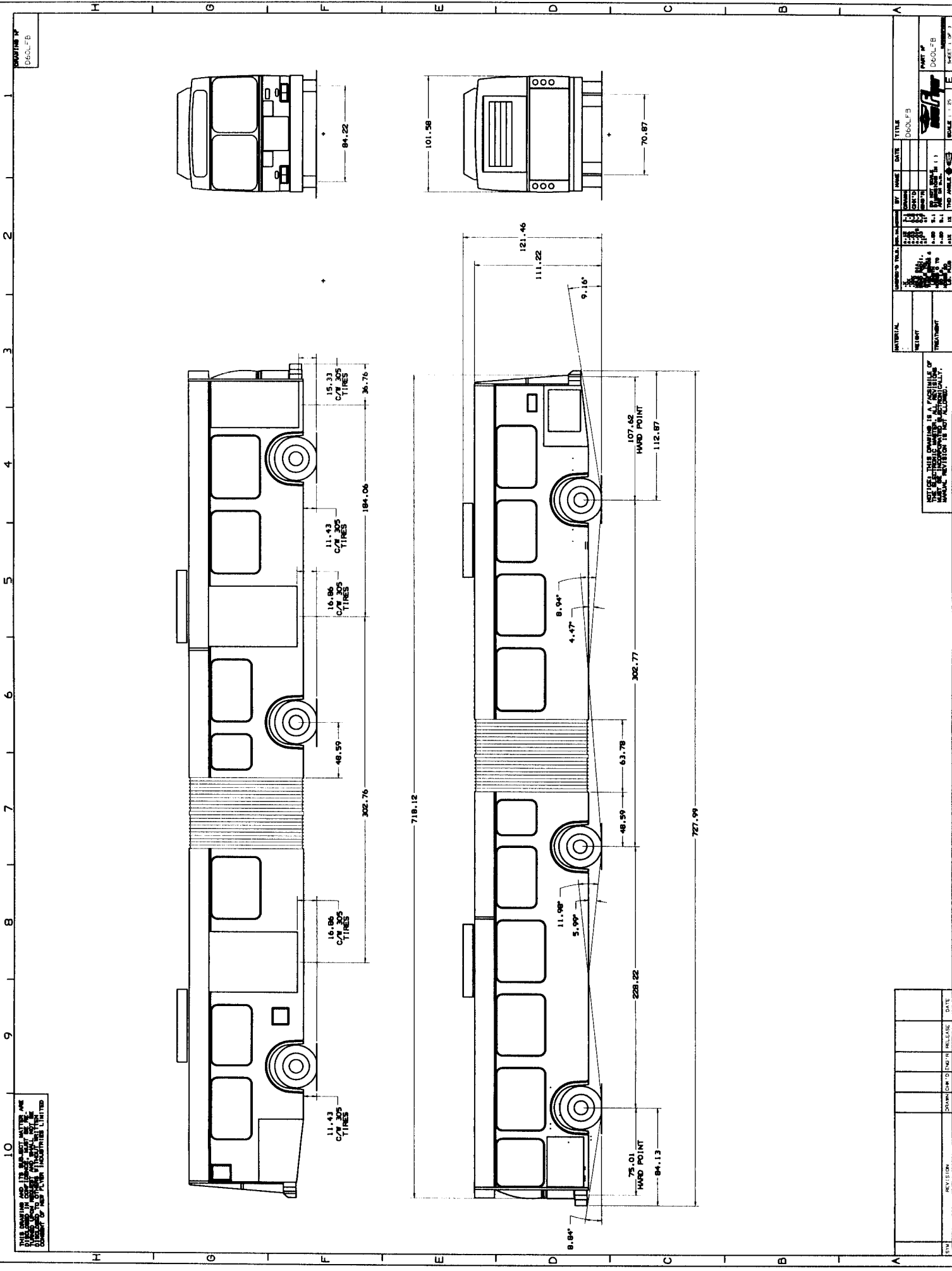

DATE: 11-20-84
 DRAWN BY: DDOLEB

ALL DIMENSIONS AND TOLERANCES ARE TO BE MAINTAINED UNLESS OTHERWISE SPECIFIED. DIMENSIONS TO CENTER UNLESS OTHERWISE SPECIFIED. DIMENSIONS TO DIMENSION LINES UNLESS OTHERWISE SPECIFIED. DIMENSIONS TO DIMENSION LINES UNLESS OTHERWISE SPECIFIED.

REV	DATE	BY	CHKD	APP'D	TITLE
1	11-20-84	DDOLEB			DDOLF3
2					
3					
4					
5					
6					
7					
8					
9					
10					

NOTICE: THIS DRAWING IS A FACSIMILE OF A COPY OF THE ORIGINAL DRAWING. ANY REVISIONS TO THE ORIGINAL DRAWING WILL BE INDICATED BY A REVISION SYMBOL. MANUAL REVISION IS NOT ALLOWED.

REV	REVISION	DATE
1		
2		
3		
4		
5		
6		
7		
8		
9		
10		

THIS DRAWING AND ITS DIMENSIONS ARE
 TO BE USED IN CONNECTION WITH THE
 DIMENSIONS TO OTHER DRAWINGS IN THE
 DRAWING OF THIS FORD MOTOR COMPANY LIMITED

WORKING VIEW
 DEGC-LFB

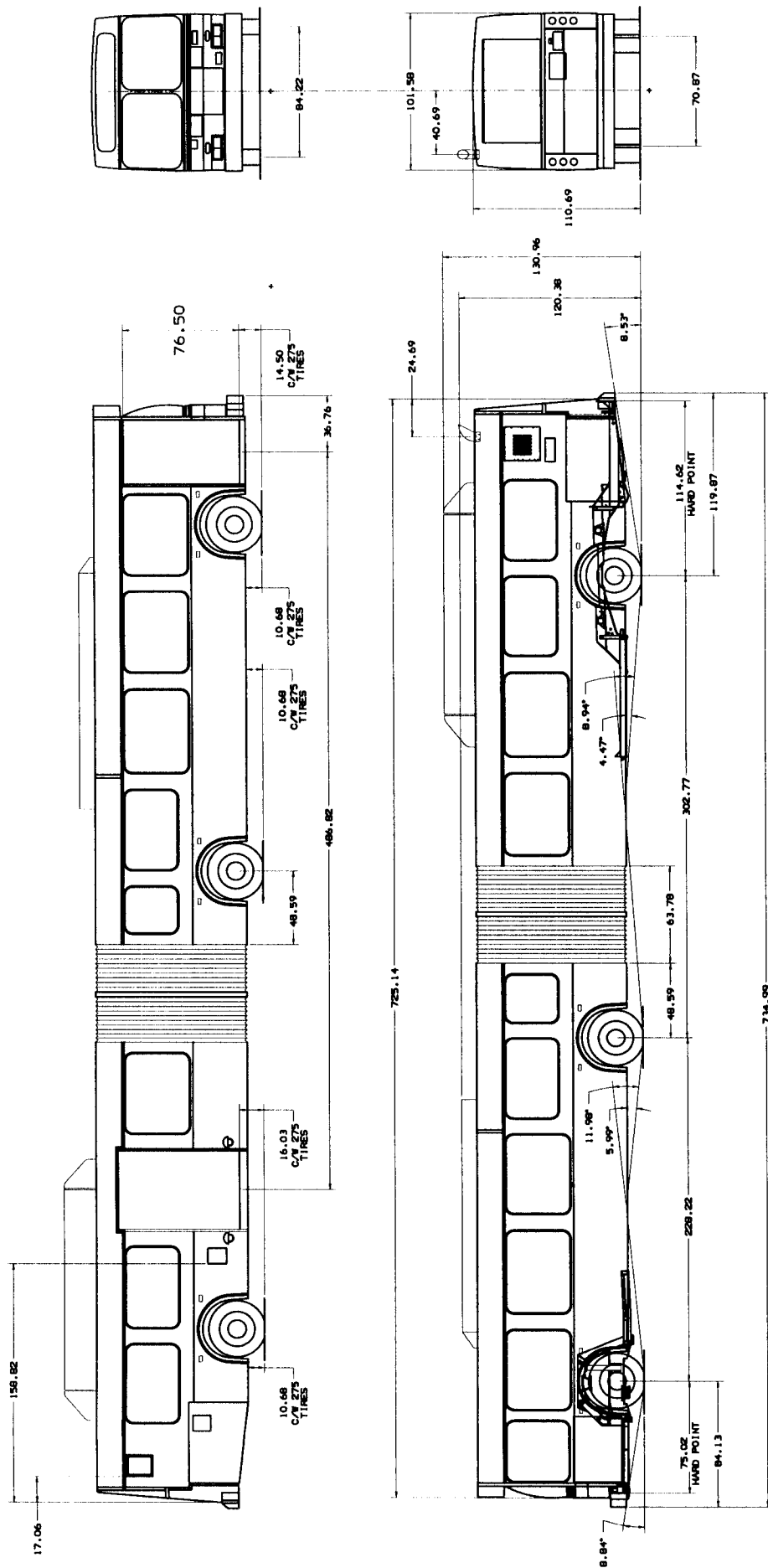

ADD 0.62 ±.25 INCHES TO ALL VERTICAL DIMENSIONS
 AND .65° TO ALL ANGLES
 WHEN USING 305 TIRES

REV. NO.	DESCRIPTION	DATE	BY	CHK'D	ENGR'G	RELEASE	DATE
10							
9							
8							
7							
6							
5							
4							
3							
2							
1							

DATE	BY	CHK'D	ENGR'G	RELEASE	DATE

REV. NO.	DESCRIPTION	DATE	BY	CHK'D	ENGR'G	RELEASE	DATE
10							
9							
8							
7							
6							
5							
4							
3							
2							
1							

REV. NO.	DESCRIPTION	DATE	BY	CHK'D	ENGR'G	RELEASE	DATE
10							
9							
8							
7							
6							
5							
4							
3							
2							
1							

REV. NO.	DESCRIPTION	DATE	BY	CHK'D	ENGR'G	RELEASE	DATE
10							
9							
8							
7							
6							
5							
4							
3							
2							
1							

REV. NO.	DESCRIPTION	DATE	BY	CHK'D	ENGR'G	RELEASE	DATE
10							
9							
8							
7							
6							
5							
4							
3							
2							
1							

REV. NO.	DESCRIPTION	DATE	BY	CHK'D	ENGR'G	RELEASE	DATE
10							
9							
8							
7							
6							
5							
4							
3							
2							
1							

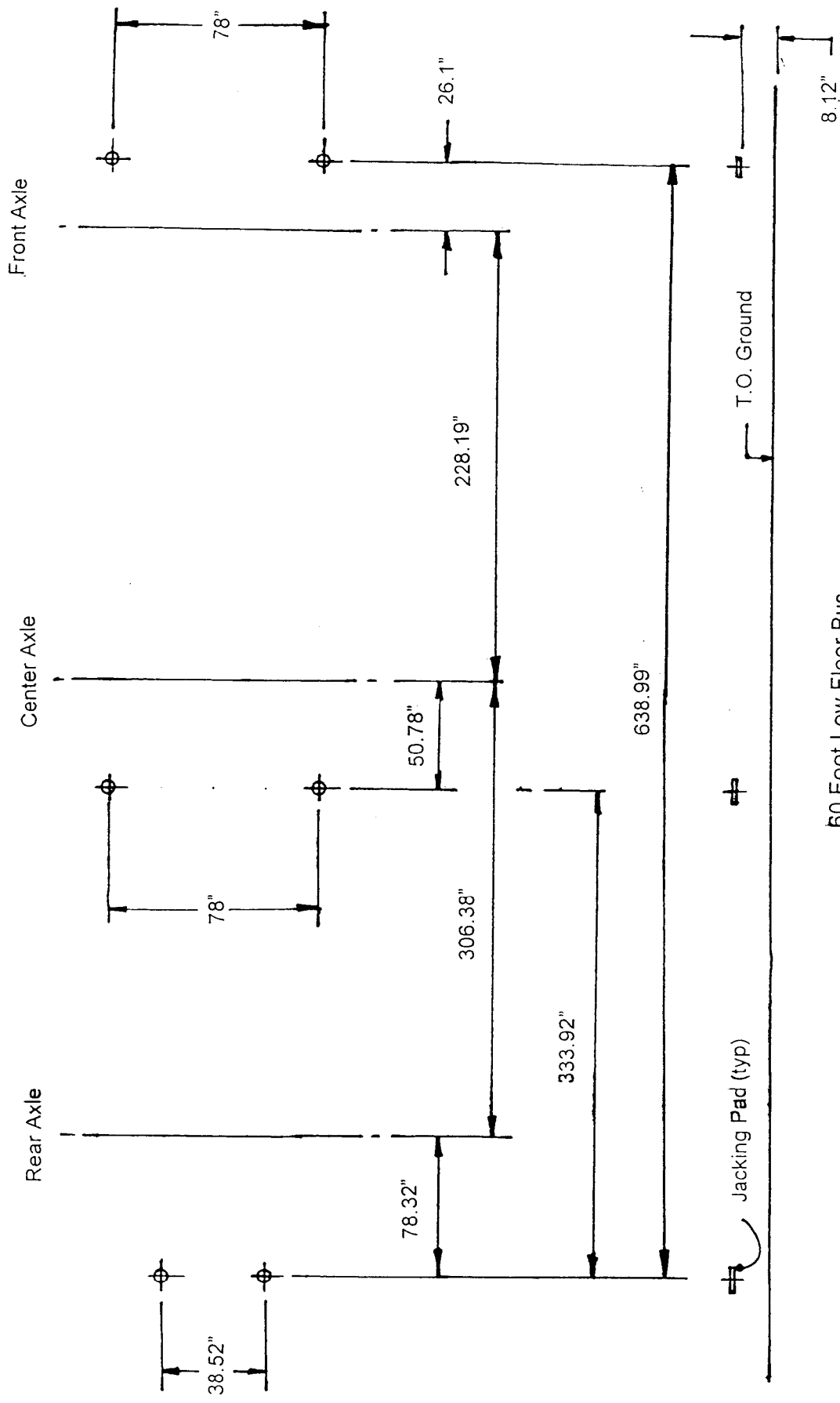

60 Foot Low Floor Bus
Jacking Pad Locations

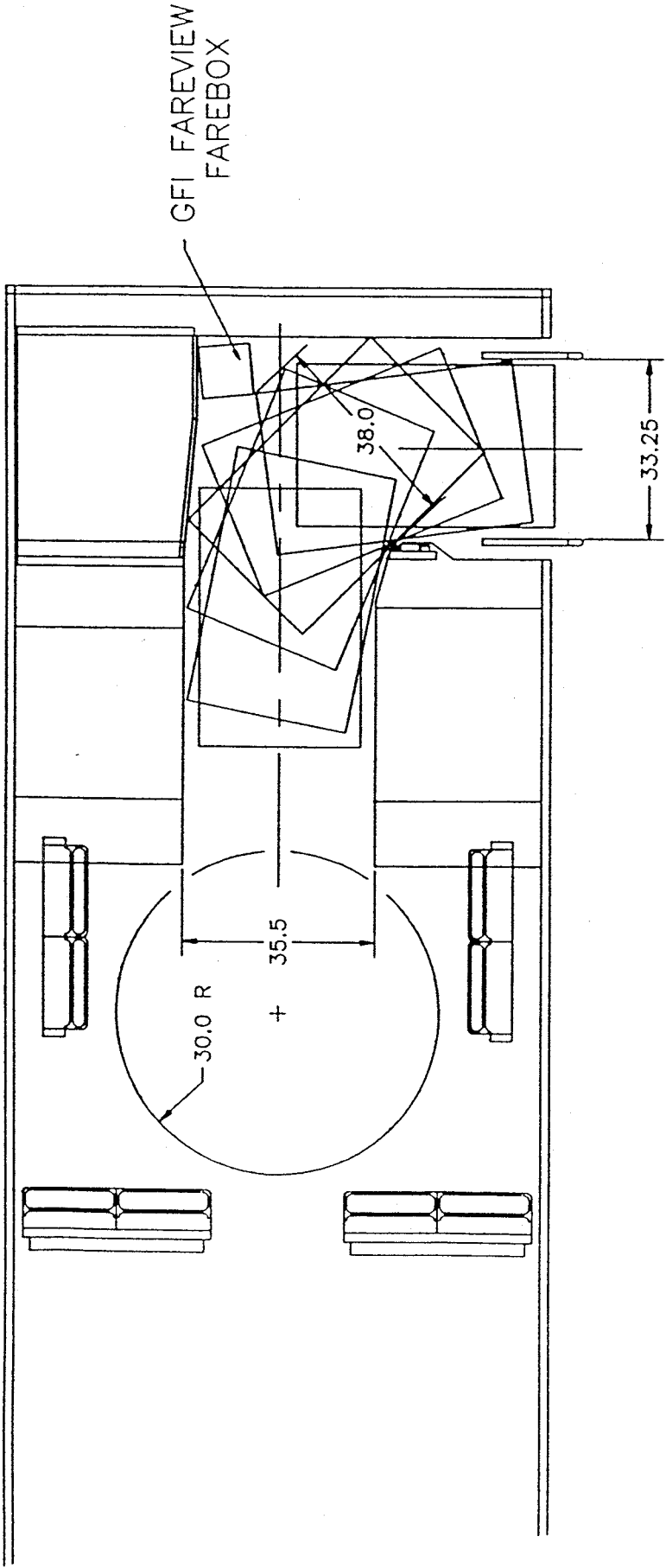

A.D.A. 30" x 48" WHEELCHAIR
TURN ALLOWANCE
LOW-FLOOR BUS

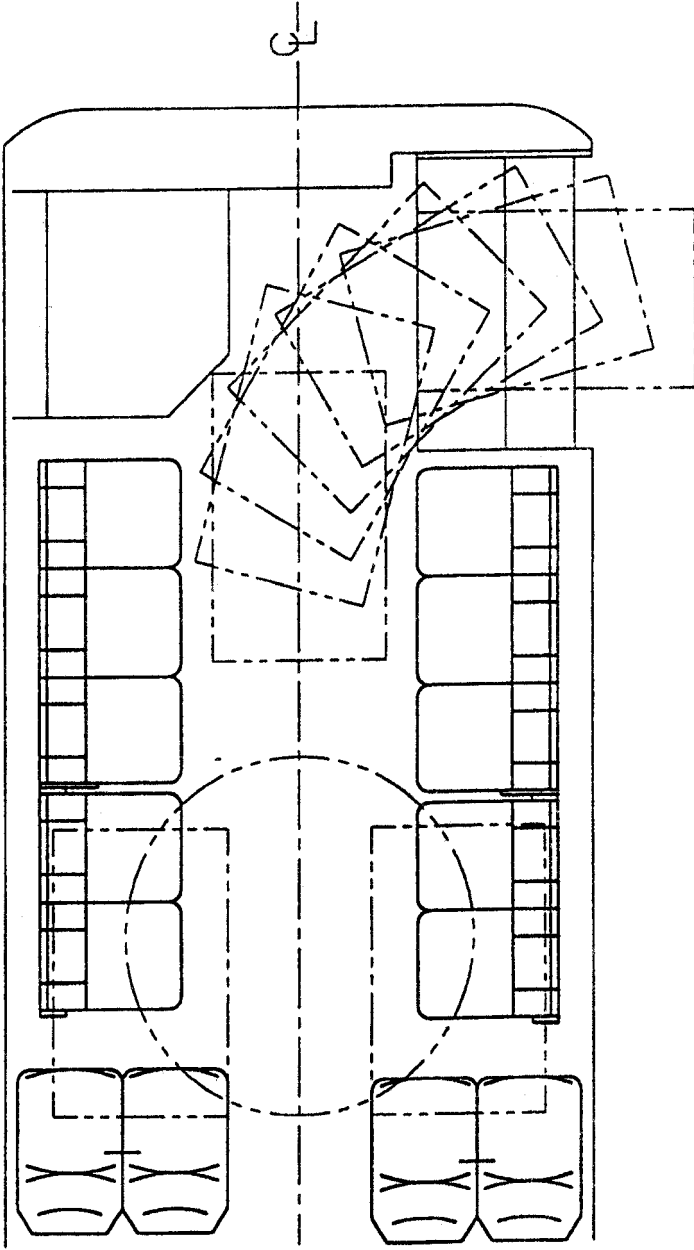

A.D.A. 30"x48" WHEELCHAIR
TURN ALLOWANCE
HIGH FLOOR BUS

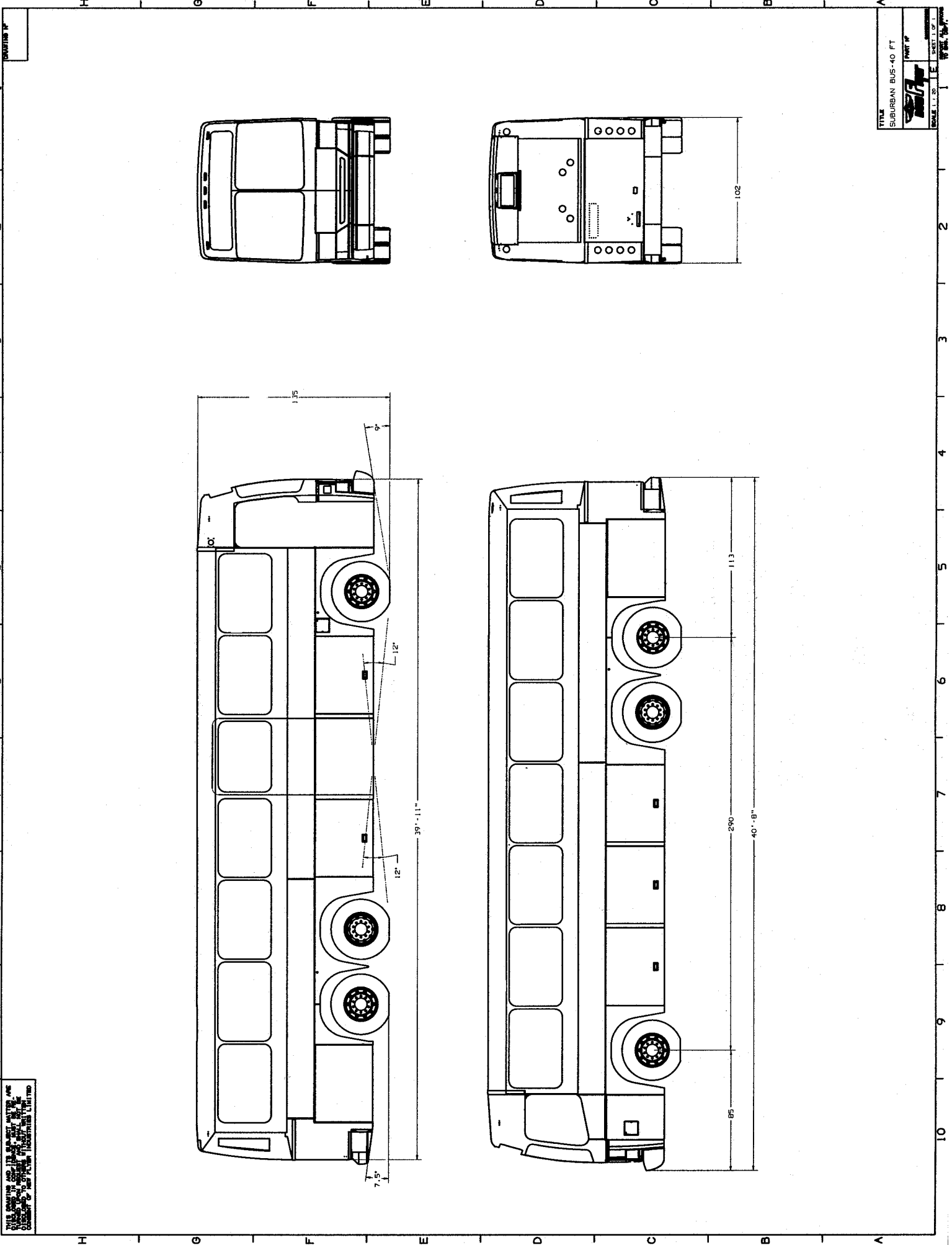

10
 7
 6
 5
 4
 3
 2
 1
 H G F E D C B A

WILLSON BUS CO. 1710 W. 10th St. W. Ave
 Grand Rapids, Mich. 49503
 COMPANY OF THE PLYMOUTH INDUSTRIES LIMITED

H G F E D C B A

TITLE
 SUBURBAN BUS-40 FT

WILLSON BUS CO.
 GRAND RAPIDS, MICH.
 COMPANY OF THE PLYMOUTH INDUSTRIES LIMITED

SCALE 1:20

SHEET 1 OF 1

10
 9
 8
 7
 6
 5
 4
 3
 2
 1
 H G F E D C B A

Wij danken u voor uw bestelling

Wij danken u voor uw bestelling

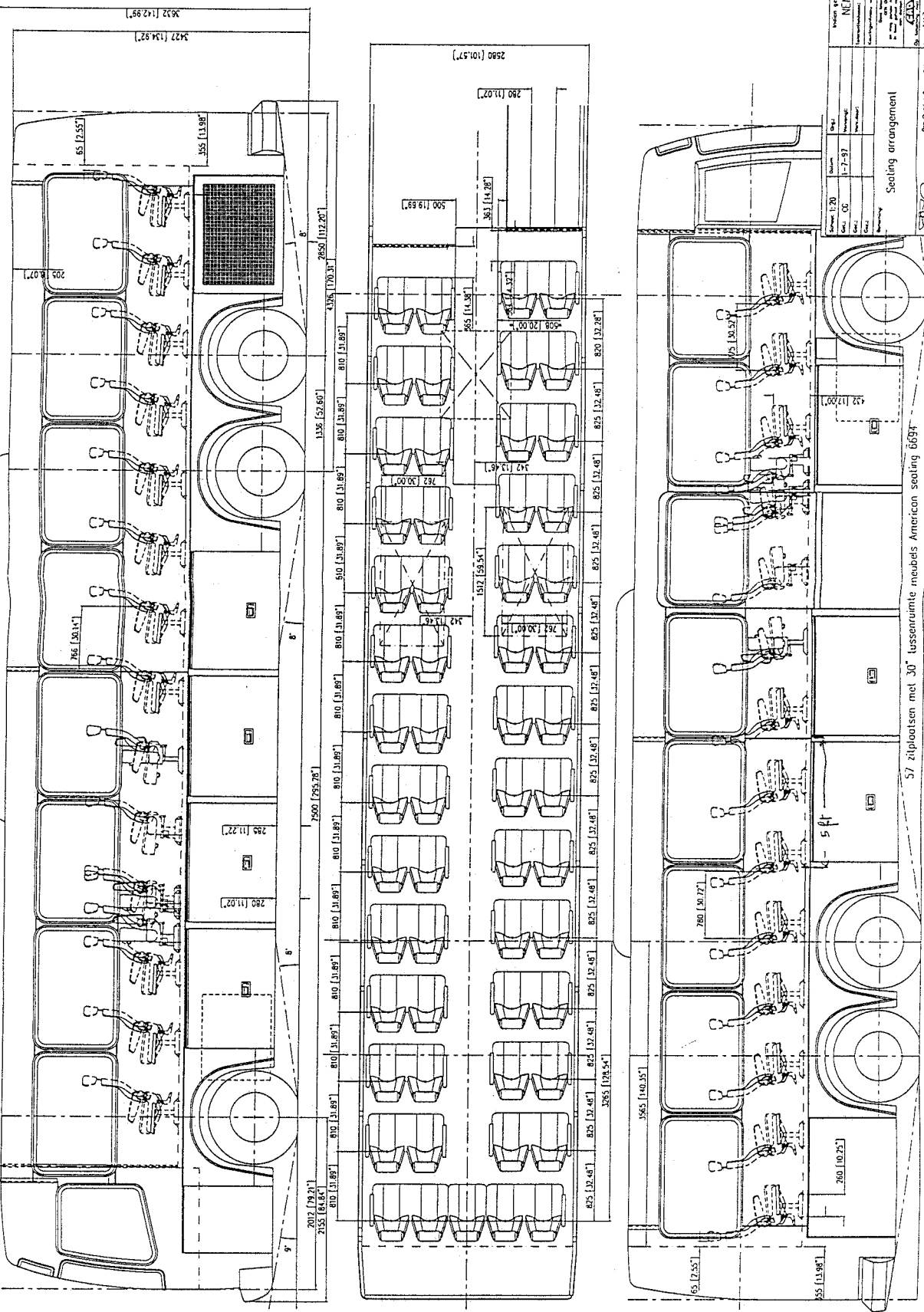

Model: 120
Code: 00
Date: 1-7-97
Scale: 1:100
Drawing: Seating arrangement

Model: 120
Code: 00
Date: 1-7-97
Scale: 1:100
Drawing: Seating arrangement

Model: 120
Code: 00
Date: 1-7-97
Scale: 1:100
Drawing: Seating arrangement

57 zitplaatsen met 30" tussenruimte meubels American seating 6699

57 zitplaatsen met 30" tussenruimte meubels American seating 6699

57 zitplaatsen met 30" tussenruimte meubels American seating 6699

Model: 120
Code: 00
Date: 1-7-97
Scale: 1:100
Drawing: Seating arrangement

THIS DRAWING AND ITS SUBJECT MATTER ARE DISCLOSED IN CONFIDENCE. JUST AS WE DISCLOSED TO OTHERS WITHOUT WRITTEN CONSENT OF NEW FLYER INDUSTRIES LIMITED

DRAWING NO
202856

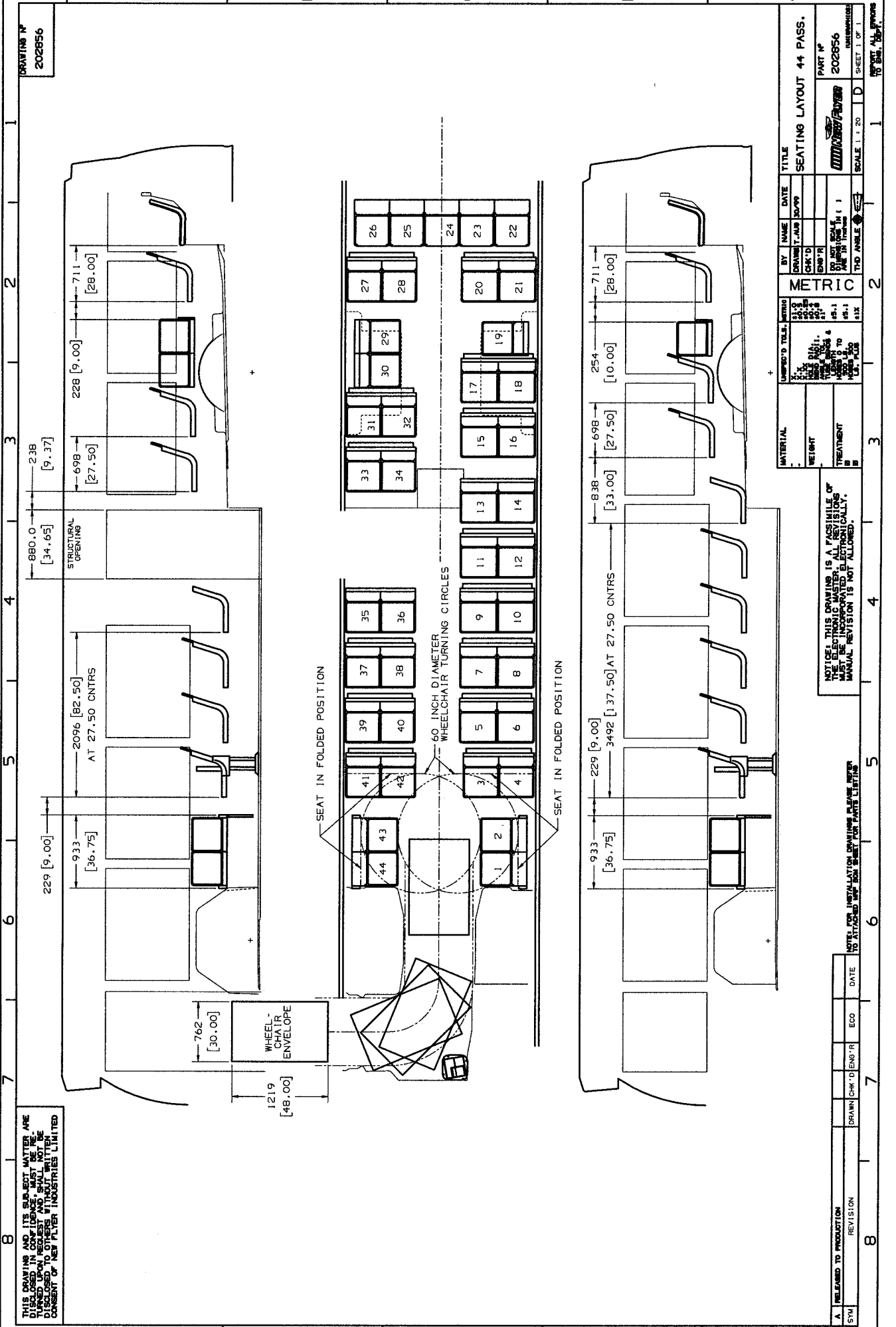

SYN	A. RELEASED TO PRODUCTION		DATE	ECO	ENG'R	DRWN	CHK'D
	REVISION						

NOTICE: THIS DRAWING IS A POSSIBILITY OF MUST BE INCORPORATED ELECTRONICALLY. MANUAL REVISION IS NOT ALLOWED.

NOTICE: METRIC UNITS ARE TO BE USED FOR ALL DIMENSIONS UNLESS OTHERWISE SPECIFIED.

NOTICE: THIS DRAWING IS A POSSIBILITY OF MUST BE INCORPORATED ELECTRONICALLY. MANUAL REVISION IS NOT ALLOWED.

MATERIAL	UNAPPROVED TOLERANCES	BY	NAME	DATE	TITLE
WEIGHT	UNAPPROVED TOLERANCES	DRWN	T. AUB	30/99	SEATING LAYOUT 44 PASS.
TREATMENT	UNAPPROVED TOLERANCES	CHK'D			
	UNAPPROVED TOLERANCES	ENG'R			
	UNAPPROVED TOLERANCES	DATE			
	UNAPPROVED TOLERANCES	SCALE	1:20		
	UNAPPROVED TOLERANCES	SHEET	1 OF 1		

NOTICE: THIS DRAWING IS A POSSIBILITY OF MUST BE INCORPORATED ELECTRONICALLY. MANUAL REVISION IS NOT ALLOWED.

NOTICE: METRIC UNITS ARE TO BE USED FOR ALL DIMENSIONS UNLESS OTHERWISE SPECIFIED.

NOTICE: THIS DRAWING IS A POSSIBILITY OF MUST BE INCORPORATED ELECTRONICALLY. MANUAL REVISION IS NOT ALLOWED.

NOTICE: METRIC UNITS ARE TO BE USED FOR ALL DIMENSIONS UNLESS OTHERWISE SPECIFIED.

NOTICE: THIS DRAWING IS A POSSIBILITY OF MUST BE INCORPORATED ELECTRONICALLY. MANUAL REVISION IS NOT ALLOWED.

NOTICE: METRIC UNITS ARE TO BE USED FOR ALL DIMENSIONS UNLESS OTHERWISE SPECIFIED.

NOTICE: THIS DRAWING IS A POSSIBILITY OF MUST BE INCORPORATED ELECTRONICALLY. MANUAL REVISION IS NOT ALLOWED.

NOTICE: METRIC UNITS ARE TO BE USED FOR ALL DIMENSIONS UNLESS OTHERWISE SPECIFIED.

SECTION A-A

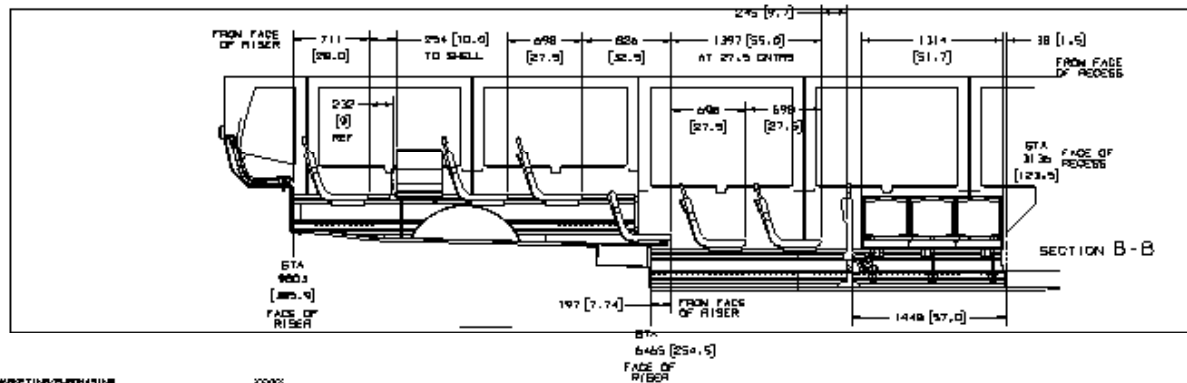
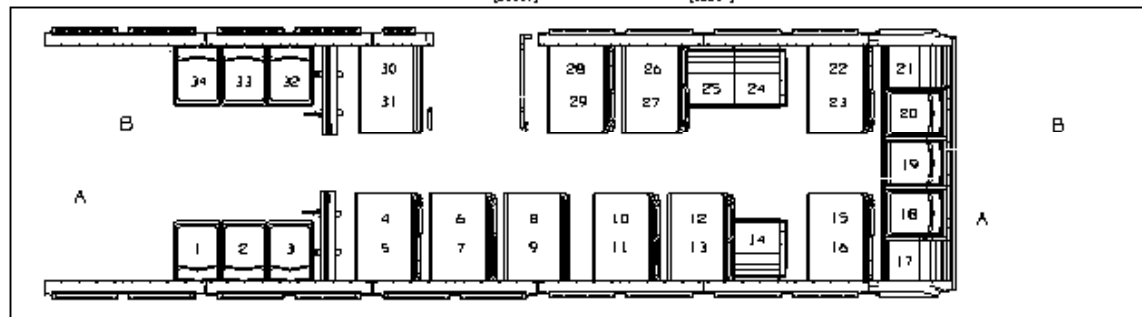
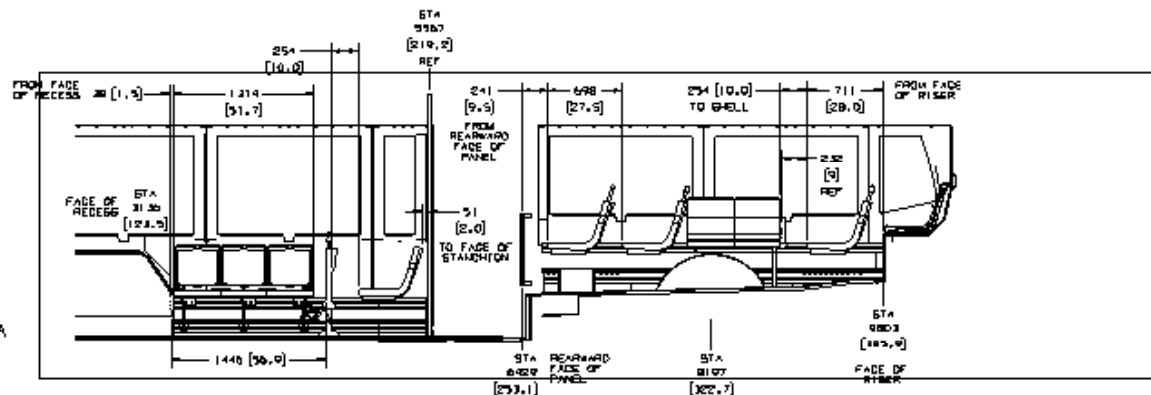

6.7. 00-00-00 INSTL-SEATING, 34 PASS.

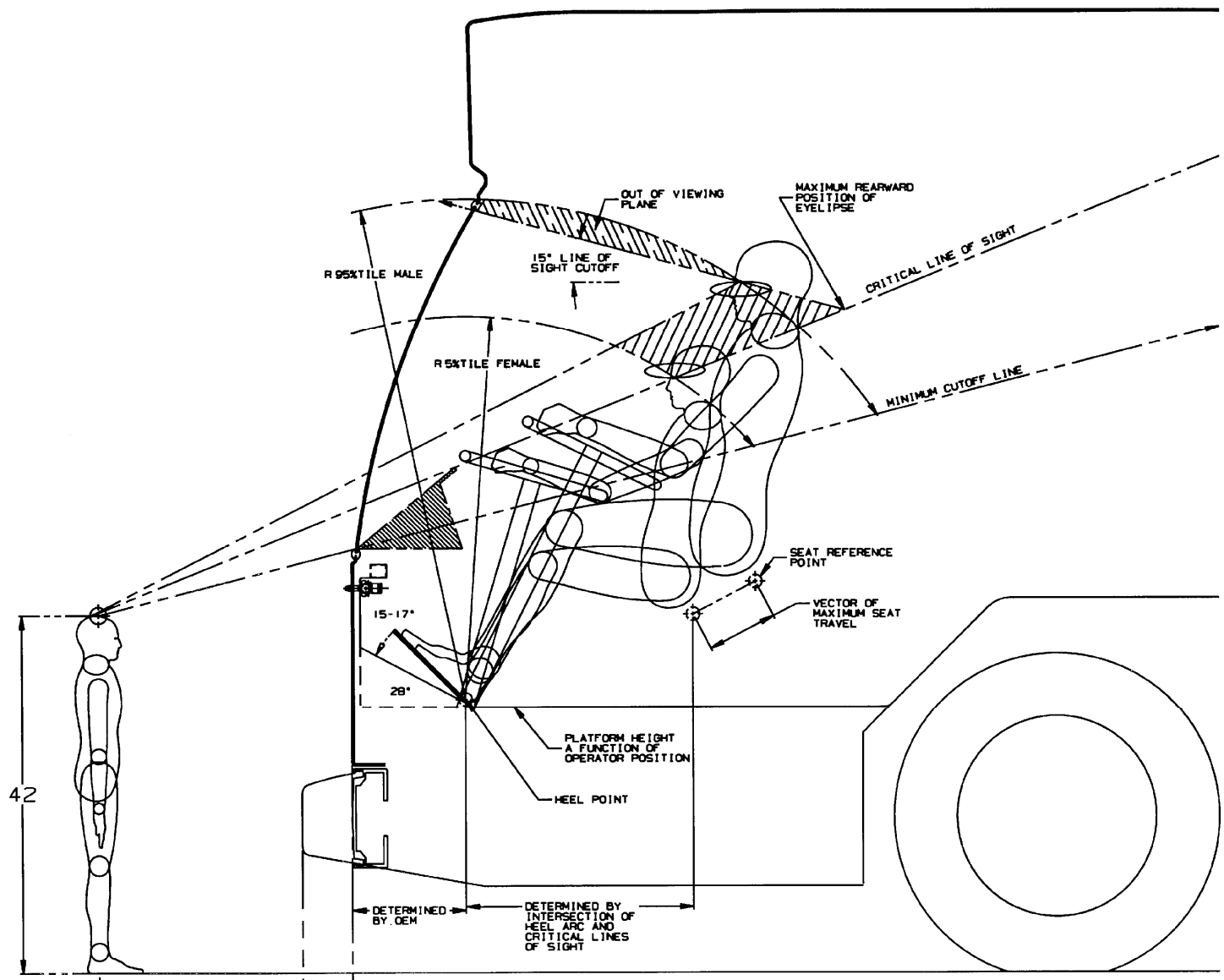

VISION:
 STANDARD EYELIPSE
 CALCULATION
 DIAGRAM

24 7 MAX

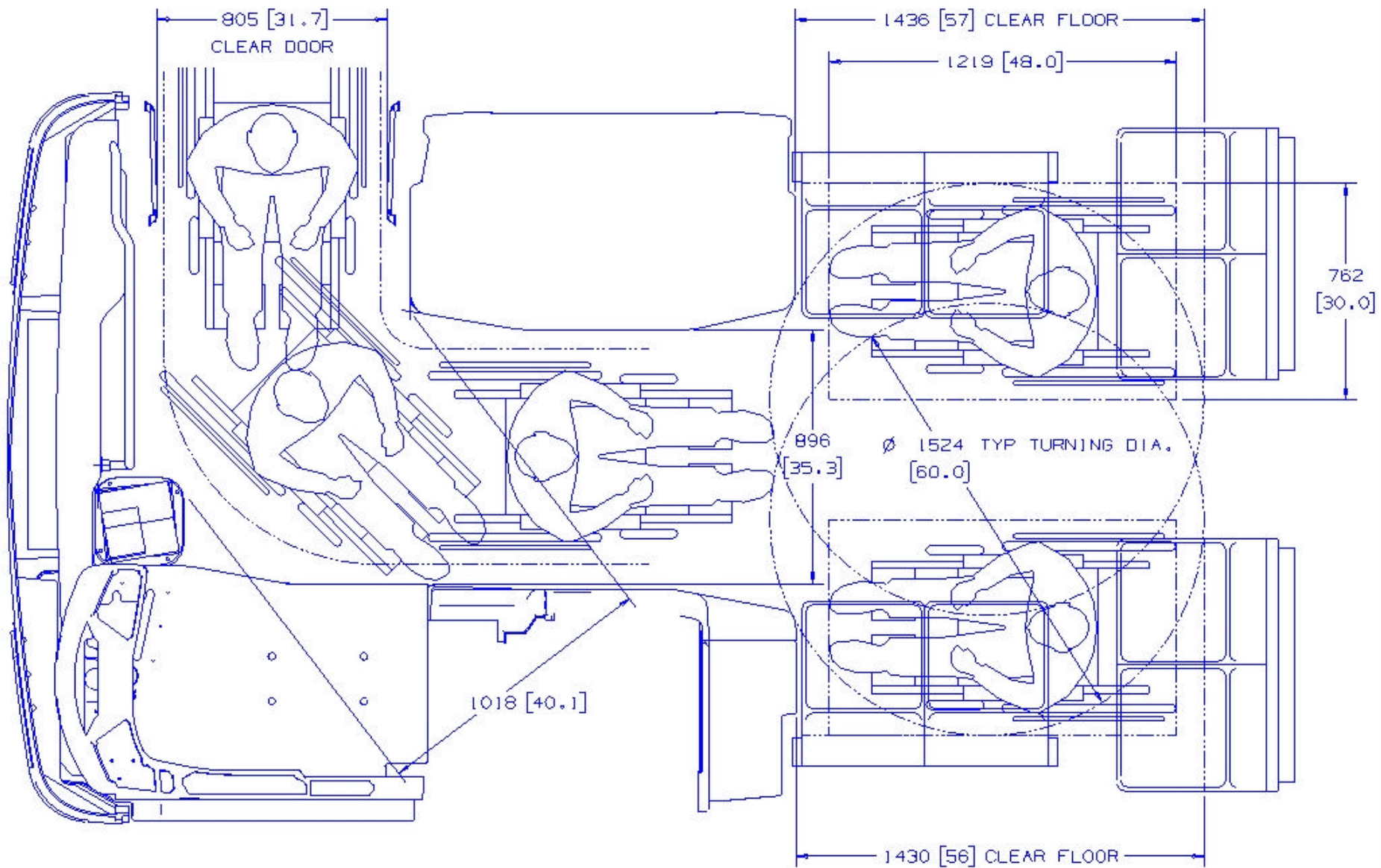

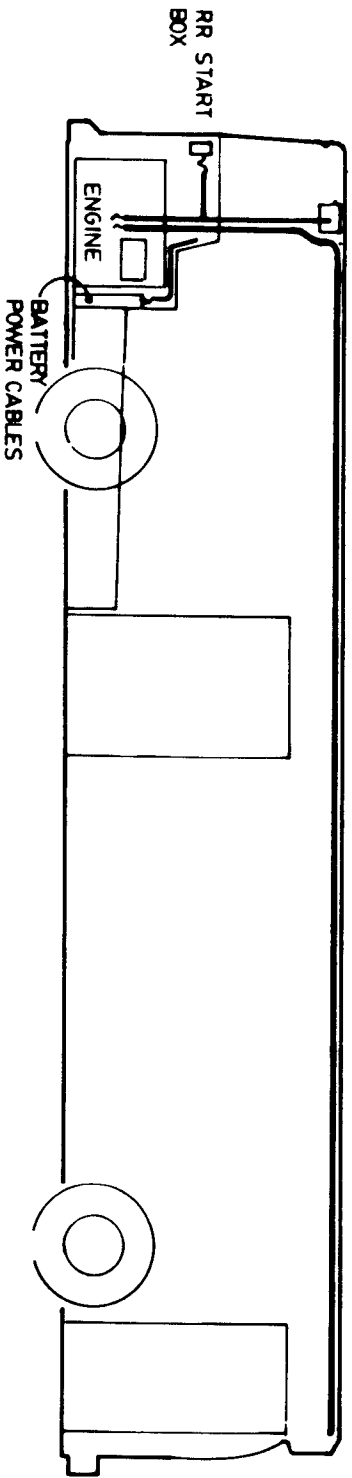
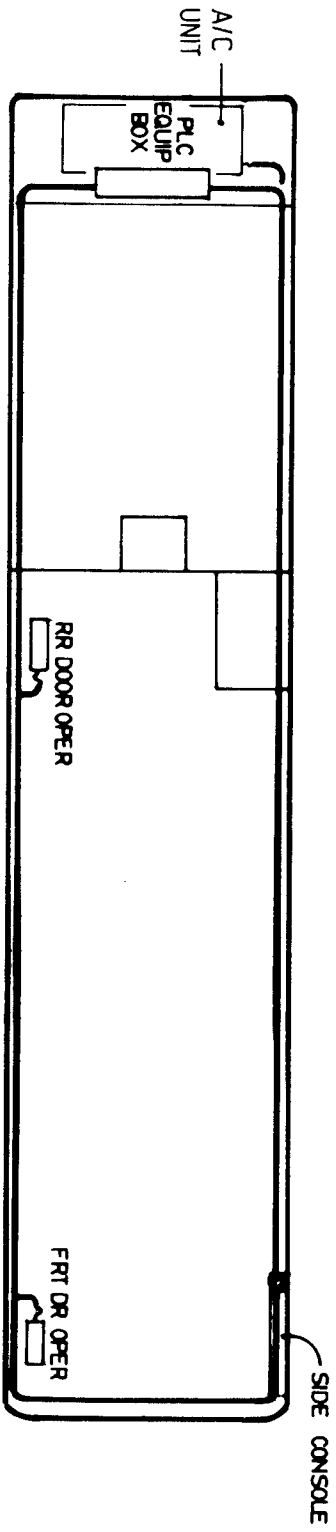
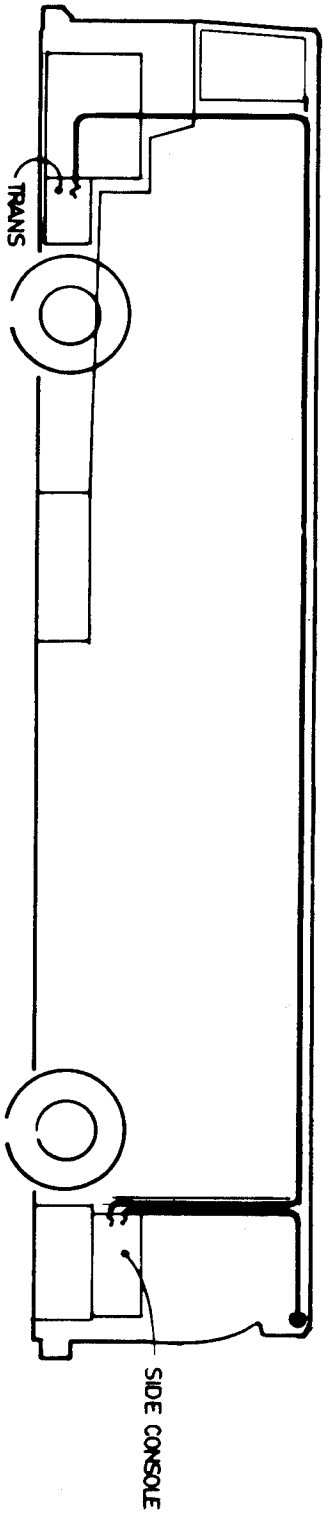

ELECTRICAL CONNECTION AREAS

Tow eyes are mounted on the front of the coach for towing purposes. Tow bars are welded into the rear frame for rear towing.

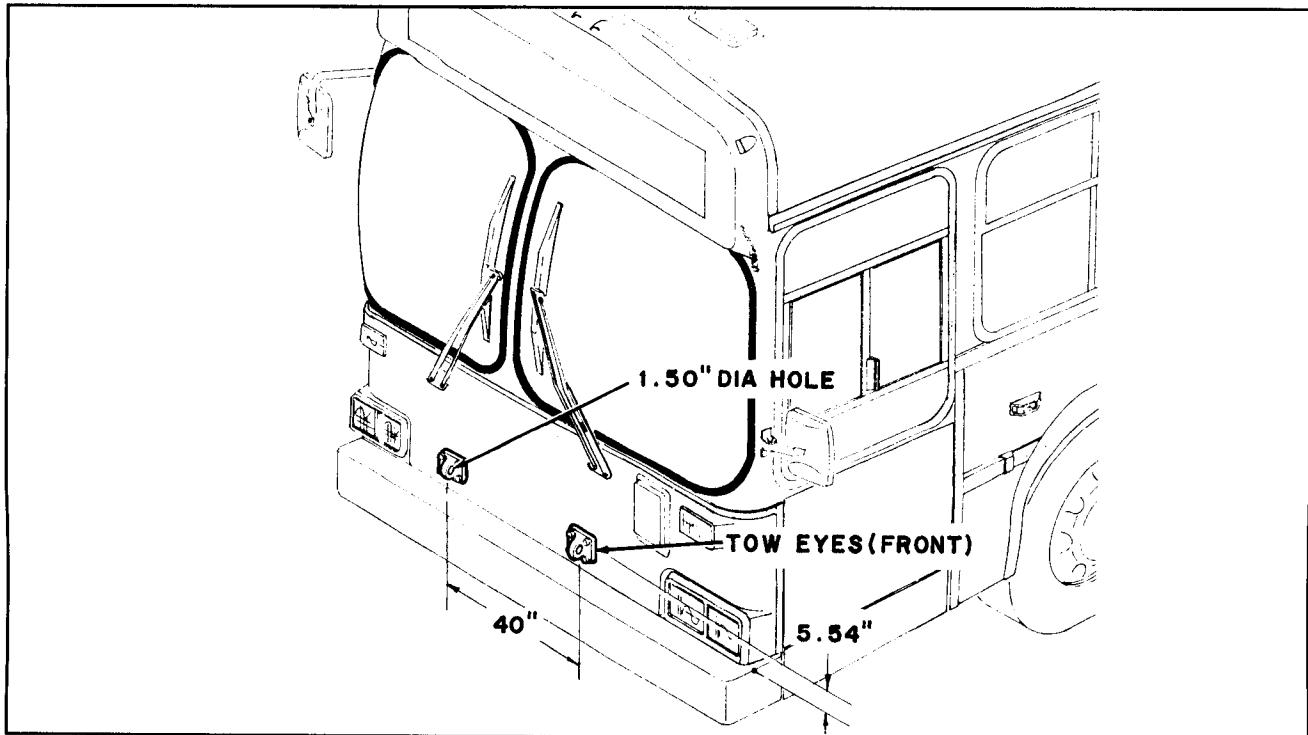

Front Towing Provision

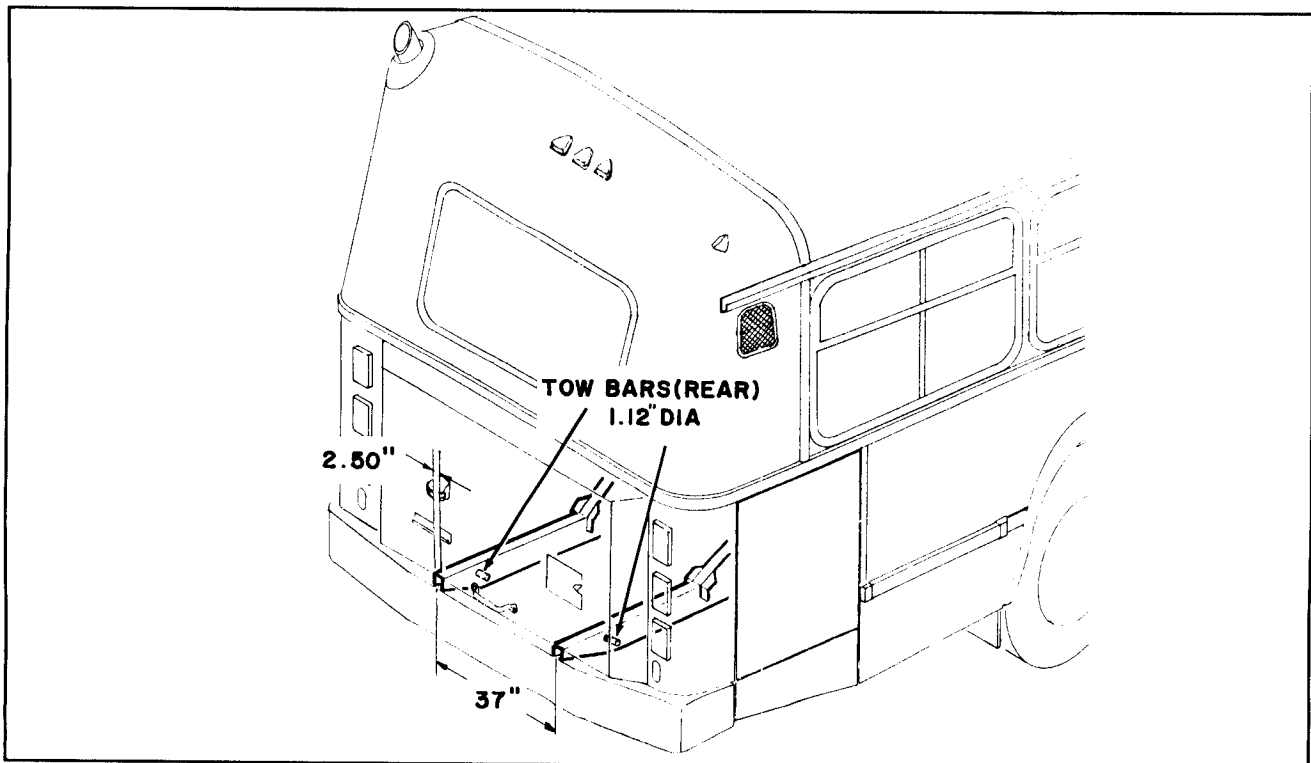

Rear Towing Provision

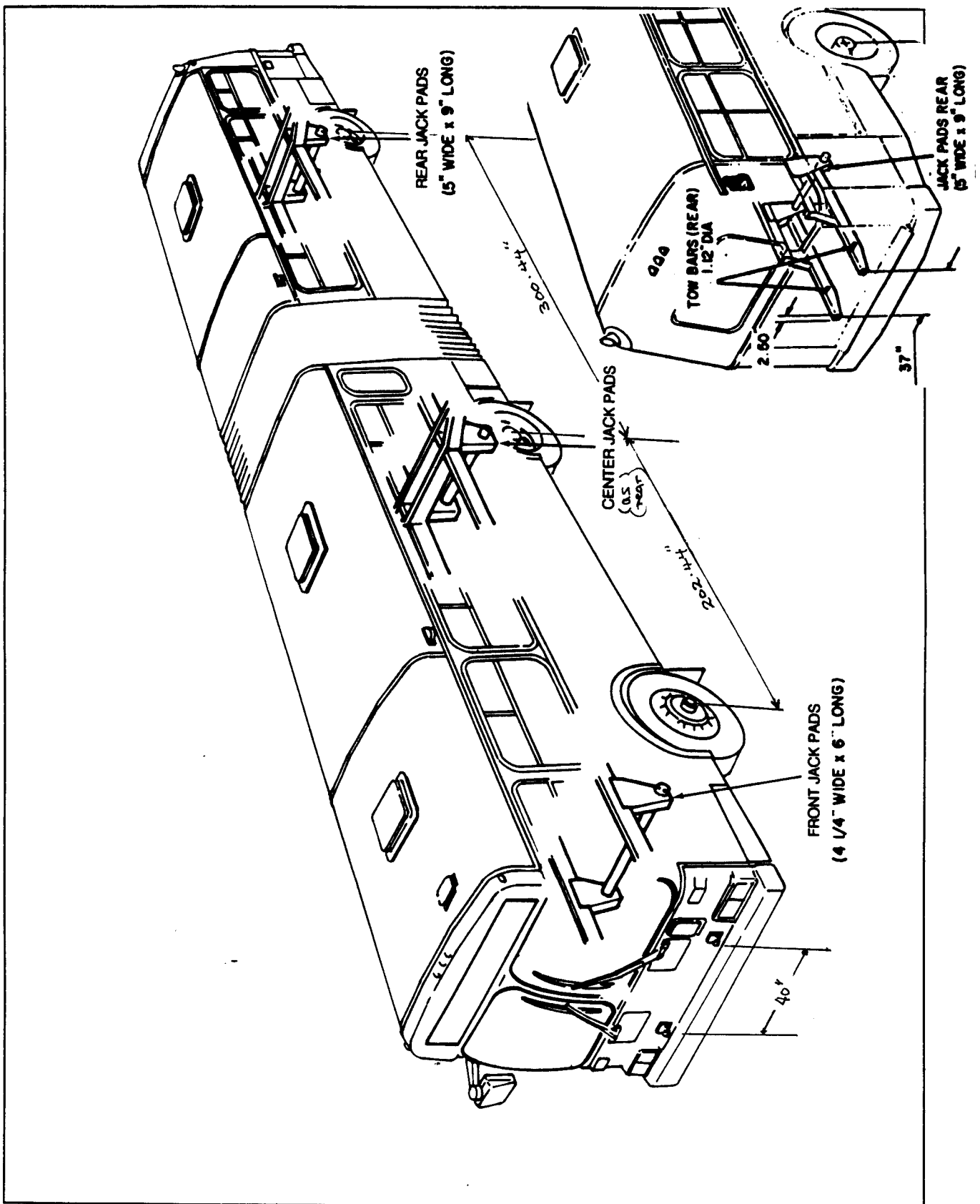

FIGURE 1-13: Tow Points and Jack Pads

Length (over bumpers)	60.7 ft. (18.5 m)
Width	8.5 ft. (2.6 m)
Height	9.2 ft. (2.8 m)
Wheelbase	25.5 ft. (7.8 m)
Turning Radius	42.5 ft. (12.9 m)
Pivot Angle	50°

Length (over bumpers)	41 ft. (12.5 m)
Width	8.5 ft. (2.6 m)
Height	10.5 ft. (3.2 m)
Wheelbase	23.6 ft. (7.2 m)
Turning Radius	43 ft. (13.1 m)
Approach/Departure Angle	9°
Vehicle Weight (approx.)	27,600 lbs. (12,523 kg)
Gross Vehicle Weight Rating (GVWR)	43,640 lbs. (19,795 kg)