



THE CITY OF WINNIPEG

BID OPPORTUNITY

BID OPPORTUNITY NO. 141-2014

**PROVISION OF HOURLY RATES FOR HIRED EQUIPMENT AND DUMP TRUCKS
2014-2015 CONSTRUCTION SEASON**

TABLE OF CONTENTS

PART A - BID SUBMISSION

Form A: Bid	1
Form B: Prices	3

PART B - BIDDING PROCEDURES

B1. Contract Title	1
B2. Submission Deadline	1
B3. Enquiries	1
B4. Addenda	1
B5. Substitutes	2
B6. Bid Submission	2
B7. Bid	3
B8. Prices	4

PART C - GENERAL CONDITIONS

C0. General Conditions	1
------------------------	---

PART D - SUPPLEMENTAL CONDITIONS

General

D1. General Conditions	1
D2. Scope of Work	1
D3. Definitions	1
D4. Contract Administrator	1
D5. Contractor's Supervisor	1
D6. Notices	1

Submissions

D7. Authority to Carry on Business	2
D8. Workers Compensation	2
D9. Insurance	2

Schedule of Work

D10. Commencement	3
D13. Ownership of Information, Confidentiality and Non Disclosure	4

PART E - SPECIFICATIONS

General

E1. General	1
E2. Equipment and Truck Class Groupings	1
E3. Street Sweepers	3
E4. Equipment and Truck Reliability	8
E5. Operator's Competence and Performance	8
E6. Suspension and Removal from Callout Lists	8
E7. Owners of Equipment/Trucks and their Employees	9
E8. Safety Requirements	9
E9. Equipment Identification	10
E10. Work Tickets	10
E11. Substitutions, Replacements and Availability	11
E12. Withdrawal of Equipment/Trucks Prior to Layoff	12
E13. Re-Arrangement ("Bumping") of Hired Equipment and Trucks	12
E14. Contractor's Office and Phone Numbers	12
E15. Specialized Equipment, Trucks and Dump Trucks	12
E16. Payment For Rippers and Low Bed Trailers	12
E17. Rate Adjustments – Extreme Fuel Cost Fluctuations	13
E18. Prime Contractor – The Workplace Safety and Health Act (Manitoba)	13

E19. Payment Schedule	13
E20. Duplication of Make, Model and Serial Number	13
E21. Working More Than One Shift/Day	13
E22. Equipment Co-ordinator	14
E23. Respectful Workplace	14
E24. Resolution of disputes	14
E25. Water and Sewer Excavation Work	14
E26. Driver's License for Hired Hourly Trucks and Equipment	15
E27. Basis for Hiring and Layoff	15

Appendix A

Appendix B

Appendix C

Appendix D

PART B - BIDDING PROCEDURES

B1. CONTRACT TITLE

B1.1 PROVISION OF HOURLY RATES FOR HIRED EQUIPMENT AND DUMP TRUCKS 2014-2015 CONSTRUCTION SEASON

B2. SUBMISSION DEADLINE

B2.1 The Submission Deadline is 4:00 p.m. Winnipeg time, March 7, 2014.

B2.2 Bids determined by the Manager of Materials to have been received later than the Submission Deadline will not be accepted and will be returned upon request.

B2.3 The Contract Administrator or the Manager of Materials may extend the Submission Deadline by issuing an addendum at any time prior to the time and date specified in B2.1.

B3. ENQUIRIES

B3.1 All enquiries shall be directed to the Contract Administrator identified in D4.1.

B3.2 If the Bidder finds errors, discrepancies or omissions in the Bid Opportunity, or is unsure of the meaning or intent of any provision therein, the Bidder shall promptly notify the Contract Administrator of the error, discrepancy or omission at least five (5) Business Days prior to the Submission Deadline.

B3.3 If the Bidder is unsure of the meaning or intent of any provision therein, the Bidder should request clarification as to the meaning or intent prior to the Submission Deadline.

B3.4 Responses to enquiries which, in the sole judgment of the Contract Administrator, require a correction to or a clarification of the Bid Opportunity will be provided by the Contract Administrator to all Bidders by issuing an addendum.

B3.5 Responses to enquiries which, in the sole judgment of the Contract Administrator, do not require a correction to or a clarification of the Bid Opportunity will be provided by the Contract Administrator only to the Bidder who made the enquiry.

B3.6 The Bidder shall not be entitled to rely on any response or interpretation received pursuant to B3 unless that response or interpretation is provided by the Contract Administrator in writing.

B4. ADDENDA

B4.1 The Contract Administrator may, at any time prior to the Submission Deadline, issue addenda correcting errors, discrepancies or omissions in the Bid Opportunity, or clarifying the meaning or intent of any provision therein.

B4.2 The Contract Administrator will issue each addendum at least two (2) Business Days prior to the Submission Deadline, or provide at least two (2) Business Days by extending the Submission Deadline.

B4.2.1 Addenda will be available on the Bid Opportunities page at The City of Winnipeg, Corporate Finance, Materials Management Division website at <http://www.winnipeg.ca/matmgt/bidopp.asp>

B4.2.2 The Bidder is responsible for ensuring that he/she has received all addenda and is advised to check the Materials Management Division website for addenda regularly and shortly before the Submission Deadline, as may be amended by addendum.

B4.3 The Bidder shall acknowledge receipt of each addendum in Paragraph 8 of Form A: Bid. Failure to acknowledge receipt of an addendum may render a Bid non-responsive.

B5. SUBSTITUTES

- B5.1 The Work is based on the Plant, Materials and methods specified in the Bid Opportunity.
- B5.2 Substitutions shall not be allowed unless application has been made to and prior approval has been granted by the Contract Administrator in writing.
- B5.3 Requests for approval of a substitute will not be considered unless received in writing by the Contract Administrator at least five (5) Business Days prior to the Submission Deadline.
- B5.4 The Bidder shall ensure that any and all requests for approval of a substitute:
- (a) provide sufficient information and details to enable the Contract Administrator to determine the acceptability of the Plant, Material or method as either an approved equal or alternative;
 - (b) identify any and all changes required in the applicable Work, and all changes to any other Work, which would become necessary to accommodate the substitute;
 - (c) identify any anticipated cost or time savings that may be associated with the substitute;
 - (d) certify that, in the case of a request for approval as an approved equal, the substitute will fully perform the functions called for by the general design, be of equal or superior substance to that specified, is suited to the same use and capable of performing the same function as that specified and can be incorporated into the Work, strictly in accordance with the proposed work schedule and the dates specified in the Supplemental Conditions for Substantial Performance and Total Performance;
 - (e) certify that, in the case of a request for approval as an approved alternative, the substitute will adequately perform the functions called for by the general design, be similar in substance to that specified, is suited to the same use and capable of performing the same function as that specified and can be incorporated into the Work, strictly in accordance with the proposed work schedule and the dates specified in the Supplemental Conditions for Substantial Performance and Total Performance.
- B5.5 The Contract Administrator, after assessing the request for approval of a substitute, may in his/her sole discretion grant approval for the use of a substitute as an “approved equal” or as an “approved alternative”, or may refuse to grant approval of the substitute.
- B5.6 The Contract Administrator will provide a response in writing, at least two (2) Business Days prior to the Submission Deadline, only to the Bidder who requested approval of the substitute.
- B5.6.1 The Bidder requesting and obtaining the approval of a substitute shall be entirely responsible for disseminating information regarding the approval to any person or persons he/she wishes to inform.
- B5.7 If the Contract Administrator approves a substitute as an “approved equal”, any Bidder may use the approved equal in place of the specified item.
- B5.8 If the Contract Administrator approves a substitute as an “approved alternative”, any Bidder bidding that approved alternative may base his/her Total Bid Price upon the specified item but may also indicate an alternative price based upon the approved alternative. Such alternatives will be evaluated in accordance with B13.
- B5.9 No later claim by the Contractor for an addition to the Total Bid Price because of any other changes in the Work necessitated by the use of an approved equal or an approved alternative will be considered.

B6. BID SUBMISSION

- B6.1 The Bid shall consist of the following components:
- (a) Form A: Bid; and
 - (b) At least one (1) of the following Form B: Price, hard copy;

- (i) Dump Truck's only;
- (ii) Streets Sweepers only – Spring Clean-up;
- (iii) Streets Sweepers only – Regular and Fall;
- (iv) Streets Sweepers only – Central Services;
- (v) Construction Equipment only.

- B6.2 Further to B6.1, the Bidder should include the written correspondence from the Contract Administrator approving a substitute in accordance with B5.
- B6.3 All components of the Bid shall be fully completed or provided, and submitted by the Bidder no later than the Submission Deadline, with all required entries made clearly and completely in ink, to constitute a responsive Bid.
- B6.4 Bidders are advised not to include any information/literature except as requested in accordance with B6.1.
- B6.5 Bidders are advised that inclusion of terms and conditions inconsistent with the Bid Opportunity document, including the General Conditions, will be evaluated in accordance with B13.1(a)
- B6.6 The Bid may be submitted by mail, courier or personal delivery, or by facsimile transmission.
- B6.7 If the Bid is submitted by mail, courier or personal delivery, it shall be enclosed and sealed in an envelope clearly marked with the Bid Opportunity number and the Bidder's name and address, and shall be submitted to:
- The City of Winnipeg
Corporate Finance Department
Materials Management Division
185 King Street, Main Floor
Winnipeg MB R3B 1J1
- B6.7.1 Samples or other components of the Bid which cannot reasonably be enclosed in the envelope may be packaged separately, but shall be clearly marked with the Bid Opportunity number, the Bidder's name and address, and an indication that the contents are part of the Bidder's Bid Submission.
- B6.8 If the Bid is submitted by facsimile transmission, it shall be submitted to 204- 949-1178.
- B6.8.1 The Bidder is advised that the City cannot take responsibility for the availability of the facsimile machine at any time.
- B6.9 Bids submitted by internet electronic mail (e-mail) will not be accepted.

B7. BID

- B7.1 The Bidder shall complete Form A: Bid, making all required entries.
- B7.2 Paragraph 2 of Form A: Bid shall be completed in accordance with the following requirements:
- (a) if the Bidder is a sole proprietor carrying on business in his/her own name, his/her name shall be inserted;
 - (b) if the Bidder is a partnership, the full name of the partnership shall be inserted;
 - (c) if the Bidder is a corporation, the full name of the corporation shall be inserted;
 - (d) if the Bidder is carrying on business under a name other than his/her own, the business name and the name of every partner or corporation who is the owner of such business name shall be inserted.
- B7.2.1 If a Bid is submitted jointly by two or more persons, each and all such persons shall identify themselves in accordance with B7.4.

- B7.3 In Paragraph 3 of Form A: Bid, the Bidder shall identify a contact person who is authorized to represent the Bidder for purposes of the Bid.
- B7.4 Paragraph 10 of Form A: Bid shall be signed in accordance with the following requirements:
- (a) if the Bidder is a sole proprietor carrying on business in his/her own name, it shall be signed by the Bidder;
 - (b) if the Bidder is a partnership, it shall be signed by the partner or partners who have authority to sign for the partnership;
 - (c) if the Bidder is a corporation, it shall be signed by its duly authorized officer or officers;
 - (d) if the Bidder is carrying on business under a name other than his/her own, it shall be signed by the registered owner of the business name, or by the registered owner's authorized officials if the owner is a partnership or a corporation.
- B7.4.1 The name and official capacity of all individuals signing Form A: Bid should be printed below such signatures.
- B7.4.2 All signatures shall be original.
- B7.5 If a Bid is submitted jointly by two or more persons, the word "Bidder" shall mean each and all such persons, and the undertakings, covenants and obligations of such joint Bidders in the Bid and the Contract, when awarded, shall be both joint and several.

B8. PRICES

- B8.1 The Bidder shall state the Make, Model, Unit and Serial Number to identify all equipment and trucks Bid, in writing on Form B: Prices – Construction Equipment and Dump Trucks. Failure to include the Make, Model, Unit and Serial Number may cause the equipment or truck Bid to be rejected.
- B8.2 The Bidder will be required to submit a copy of the vehicle registration after the submission deadline. No truck shall be placed on the Call-out list or hired out for Work until the vehicle registration has been submitted. License plate number can only be used once in Class A1, A4 and A7, no license plate number, no bid price accepted.
- B8.3 The Bidder shall bid on Form B: Prices for any or all of the following. If more than one Form B: Prices sheet is required, the Bidder may make additional copies to fill in.
- (a) Dump Trucks;
 - (b) Street Sweeping – Spring Clean Up;
 - (c) Street Sweeping – Regular & Fall;
 - (d) Street Sweeping - Central Services;
 - (e) Construction Equipment.
- B8.4 In the event that Bids from different Bidders are identical for a class of truck or equipment, the City reserves the right to have a lottery. The lottery would consist of having a draw of names to set the call-out order, with all tied Bidders being invited to attend.
- B8.5 In the event that the City errs in the slotting and/or calling out of equipment/dump trucks, the Bidder/Contractor shall have no claim against the City.
- B8.6 The Contractor shall not be compensated for rest breaks or meal breaks except as outlined below. If operational requirements permit, the City foreman may, at his discretion, allow one paid break per four hours of Work up to the maximum extent of fifteen minutes. The fifteen minutes for the break shall include travel time to and from the work site. Breaks cannot be accumulated nor will payment be owing by the City for breaks not granted or not taken.
- B8.7 All quoted hourly rental rates shall include all costs of any nature whatsoever associated with the supply and operation of the equipment and trucks, including but not limited to:

- (a) Qualified operators;
 - (b) Fuel, oil, lubrication and all maintenance;
 - (c) Any and all overtime, except as specified in B8.8 (i.e: no special or additional overtime rates will be accepted);
 - (d) Any and all travel time to the work site, except as specified in B8.8.
 - (e) All insurance and all other costs.
- B8.8 An overtime premium of \$12.95/hour will be paid for each hour of equipment/truck time worked during the weekend period 1900 hours Friday to 1900 hours Sunday.
- B8.8.1 An overtime premium will also be paid for Work on a statutory holiday or Remembrance Day. In the event that one of these holidays falls on a Friday then the premium will be paid for all equipment/truck hours worked between 1900 Thursday to 1900 Sunday. Similarly, if one of these holidays falls on a Monday, then a premium will be paid for all equipment/truck hours worked between 1900 Friday to 1900 Monday.
- B8.8.2 Should a statutory holiday or Remembrance Day fall on Tuesday, Wednesday or Thursday, an overtime premium will be paid for all hours worked from 1900 hours the day prior to 1900 hours on the day of the holiday.
- B8.8.3 Statutory holidays are New Year's Day, Louis Riel Day, Good Friday, Victoria Day, Canada Day, Labour Day, Thanksgiving Day and Christmas Day.
- B8.8.4 Any weekend or statutory holiday premium paid to the equipment/truck operator is the sole responsibility of the equipment/truck owner. Notwithstanding that the Contractor may be required by law to pay overtime to his employees if they have worked excessive hours.
- B8.9 Equipment, trucks and backhoe breaker combination will be paid two hours when reporting to job site and work is cancelled due to inclement weather. Should equipment, trucks and backhoe combination work a minimum of one hour and are sent home due to inclement weather a total of four hours will be paid, except in the case of a backhoe-breaker combination in Class M1 where the four hours would only apply to the backhoe rate (M1A). The breaker (M1B) would be paid 2 hours.
- B8.9.1 Spring Clean Up only: Streets Maintenance Division will set up a central phone number (775-7669) with a recording stating whether Work will proceed or will be cancelled for the day. The Contractor should contact this number prior to the start of a street sweeping shift.
- B8.9.2 Spring Clean Up only: Parks Division will set up a central phone number (986-3900) with a recording stating whether Work will proceed or will be cancelled for the day. The Contractor should contact this number prior to the start of a street sweeping shift.
- B8.9.3 Spring Clean Up Only: A two hour call out may be paid if spring clean-up equipment shows up at a job site and is not utilized but sent home due to inclement weather, providing the message recording cancelling the sweeping shift was not on two hours prior to the start of the shift. A total of four hours will be paid if a spring clean-up equipment works a minimum of one hour on the job site and is then sent home due to inclement weather.
- B8.9.4 A callout shall include Work assigned at one or more locations and includes Work assigned for different users.
- B8.9.5 The hourly rates quoted are from the time that equipment reaches the site until the specific Work is completed. Travel time to and from job site is the responsibility of the Contractor and the City will not pay for same. If there is any doubt the Contractor should contact Equipment Dispatch at 986-6481.
- B8.10 For the convenience of Bidders, and pursuant to, an electronic spreadsheet Form B: Prices in Microsoft Excel (.xls) format is available along with the Adobe PDF documents for this Bid Opportunity on the Bid Opportunities page at the Materials Management Branch internet website at <http://www.winnipeg.ca/matmgt>.

B9. QUALIFICATION

B9.1 The Bidder shall:

- (a) undertake to be in good standing under The Corporations Act (Manitoba), or properly registered under The Business Names Registration Act (Manitoba), or otherwise properly registered, licensed or permitted by law to carry on business in Manitoba, or if the Bidder does not carry on business in Manitoba, in the jurisdiction where the Bidder does carry on business; and
- (b) be responsible and not be suspended, debarred or in default of any obligation to the City;
- (c) be financially capable of carrying out the terms of the Contract; and
- (d) have all the necessary experience, capital, organization, and equipment to perform the Work in strict accordance with the terms and provisions of the Contract;
- (e) have successfully carried out Work, similar in nature, scope and value to the Work;
- (f) employ only Subcontractors who:
 - (i) be responsible and not be suspended, debarred or in default of any obligations to the City. A list of suspended or debarred individuals and companies is available on the Information Connection page at The City of Winnipeg, Corporate Finance, Materials Management Division website at <http://www.winnipeg.ca/matmgt/debar.stm>; and
 - (ii) have successfully carried out Work similar in nature, scope and value to the portion of the Work proposed to be subcontracted to them, and are fully capable of performing the Work required to be done in accordance with the terms of the Contract;
- (g) have a written workplace safety and health program in accordance with The Workplace Safety and Health Act (Manitoba).

B9.2 The Bidder shall submit, within three (3) Business Days of a request by the Contract Administrator, proof satisfactory to the Contract Administrator of the qualifications of the Bidder and of any proposed Subcontractor.

B8.11 The Bidder shall provide, on the request of the Contract Administrator, full access to any of the Bidder's equipment and facilities to confirm, to the Contract Administrator's satisfaction, that the Bidder's equipment and facilities are adequate to perform the Work.

B10. OPENING OF BIDS AND RELEASE OF INFORMATION

B8.1 Bid Submissions will not be opened publicly.

B8.2 A complete list of unevaluated Bids (pending review and verification of conformance with requirements) shall be available for viewing twenty-one (21) days following the Submission Deadline in Adobe Acrobat (pdf) format at The City of Winnipeg, Corporate Finance, Materials Management internet site at <http://www.winnipeg.ca/matmgt>.

B10.1 A call out list shall be established for each type of Work and class of equipment

B10.2 The Bidder is advised that any information contained in any Bid may be released if required by City policy or procedures, The Freedom of Information and Protection of Privacy Act (Manitoba), or by other authorities having jurisdiction.

B11. IRREVOCABLE BID

B11.1 The Bid(s) submitted by the Bidder shall be irrevocable for the time period specified in Paragraph 9 of Form A: Bid.

B11.2 The acceptance by the City of any Bid shall not release the Bids of the next two lowest evaluated responsive Bidders and these Bidders shall be bound by their Bids on such Work for the time period specified in Paragraph 9 of Form A: Bid.

B12. WITHDRAWAL OF BIDS

B12.1 A Bidder may withdraw his/her Bid without penalty by giving written notice to the Manager of Materials at any time prior to the Submission Deadline.

B12.1.1 Notwithstanding C22.5, the time and date of receipt of any notice withdrawing a Bid shall be the time and date of receipt as determined by the Manager of Materials.

B12.1.2 The City will assume that any one of the contact persons named in Paragraph 3 of Form A: Bid or the Bidder's authorized representatives named in Paragraph 10 of Form A: Bid, and only such person, has authority to give notice of withdrawal.

B12.1.3 If a Bidder gives notice of withdrawal prior to the Submission Deadline, the Manager of Materials will:

- (a) retain the Bid until after the Submission Deadline has elapsed;
- (b) open the Bid to identify the contact person named in Paragraph 3 of Form A: Bid and the Bidder's authorized representatives named in Paragraph 10 of Form A: Bid; and
- (c) if the notice has been given by any one of the persons specified in B12.1.3(b), declare the Bid withdrawn.

B12.2 A Bidder who withdraws his/her Bid after the Submission Deadline but before his/her Bid has been released or has lapsed as provided for in B11.2 shall be liable for such damages as are imposed upon the Bidder by law and subject to such sanctions as the Chief Administrative Officer considers appropriate in the circumstances. The City, in such event, shall be entitled to all rights and remedies available to it at law.

B13. EVALUATION OF BIDS

B13.1 Award of the Contract shall be based on the following bid evaluation criteria:

- (a) compliance by the Bidder with the requirements of the Bid Opportunity, or acceptable deviation therefrom (pass/fail);
- (b) qualifications of the Bidder and the Subcontractors, if any, pursuant to B8.1.(pass/fail);
- (c) Call Out List for Dump Trucks will be determined on Price per Hour;
- (d) Call Out List for all other Equipment will be determined as per B13.4

B13.2 Further to B13.1(a), the Award Authority may reject a Bid as being non-responsive if the Bid Submission is incomplete, obscure or conditional, or contains additions, deletions, alterations or other irregularities. The Award Authority may reject all or any part of any Bid, or waive technical requirements or minor informalities or irregularities if the interests of the City so require.

B13.3 Further to B13.1(b), the Award Authority shall reject any Bid submitted by a Bidder who does not demonstrate, in his/her Bid or in other information required to be submitted, that he/she is responsible and qualified.

B13.4 For the purpose of determining the call out list for other equipment, the following slotting formula will be used:

- (a) Equipment manufactured after 2011 shall be given a 30% slotting price per hour advantage;
- (b) Equipment manufactured after 2008 shall be given a 25% slotting price per hour advantage;
- (c) Equipment manufactured after 2005 shall be given a 20% slotting price per hour

- advantage;
- (d) Equipment manufactured after 2002 shall be given a 15% slotting price per hour advantage; and
 - (e) Equipment manufactured after 1999 shall be given a 10% slotting price per hour
 - (f) advantage; and
 - (g) Equipment manufactured in 1999 and prior years, shall be given no price per hour slotting advantage.

For Example:

	Year	Bid	Slotting Price	Advantage
Equipment Age:	a) 2012	\$40.00	\$28.00	30%
	b) 2009	\$40.00	\$30.00	25%
	b) 2006	\$40.00	\$32.00	20%
	c) 2003	\$40.00	\$34.00	15%
	d) 2000	\$40.00	\$36.00	10%
	e) 1999 or prior	\$40.00	\$40.00	0%

- B13.5 When a combination unit is Bid, both serial numbers must be supplied (eg. truck and air compressor).
- B13.6 For the backhoe/breaker combination, it is anticipated that the backhoe will be used seventy-five percent of the time and the backhoe/breaker combination twenty-five percent of the time, the low Bid (for slotting purposes only) for the combined unit will be determined by adding seventy-five percent of the backhoe rate and twenty-five percent of the combined backhoe/breaker rate (both backhoe/breaker are slotted based on age clause.) The 75%/25% backhoe/breaker use ratio stated is an estimate only and is not meant to imply any guaranteed hours of usage for either the backhoe or hydraulic breaker.
- B13.7 The truck/air compressor combination in class L1 will be given a slotting position based on the age of the air compressor.
- B13.8 Only original equipment manufactured (O.E.M.) serial numbers to be used.

B14. AWARD OF CONTRACT

- B14.1 The Bid Opportunity is establish pay rates and a hiring order for all classes of dump trucks and construction equipment identified for the 2014-2015 Construction Season. Rates quoted are for equipment that is utilized for spring clean-up operation shall be effective from the start of the 2013 spring clean-up program. The 2014-2015 construction seasons for all other equipment shall be April 08, 2014 to April 07, 2015.
- B14.1.1 Without limiting the generality of B14.1 the City will have no obligation to award a Contract where:
 - (a) the prices exceed the available City funds for the Work;
 - (b) the prices are materially in excess of the prices received for similar work in the past;

- (c) the prices are materially in excess of the City's cost to perform the Work, or a significant portion thereof, with its own forces;
- (d) only one Bid is received; or
- (e) in the judgment of the Award Authority, the interests of the City would best be served by not awarding a Contract.

B14.2 This Bid Opportunity shall not be interpreted by the Contractor(s) as an obligation on the part of the City to provide Work, or as a representation that Work is available. Work, if and when available, at the discretion of the Manager of Streets Maintenance Division, shall be assigned in accordance with the terms and conditions of the Bid Opportunity.

PART C - GENERAL CONDITIONS

C0. GENERAL CONDITIONS

- C0.1 The *General Conditions for Supply of Services* (Revision 2007 04 12) are applicable to the Work of the Contract.
- C0.1.1 The *General Conditions for Supply of Services* are available on the Information Connection page at The City of Winnipeg, Corporate Finance, Materials Management Division website at http://www.winnipeg.ca/matmgt/gen_cond.stm
- C0.2 A reference in the Bid Opportunity to a section, clause or subclause with the prefix “**C**” designates a section, clause or subclause in the *General Conditions for Supply of Services*.

PART D - SUPPLEMENTAL CONDITIONS

GENERAL

D1. GENERAL CONDITIONS

D1.1 In addition to the *General Conditions for Supply of Services*, these Supplemental Conditions are applicable to the Work of the Contract.

D2. SCOPE OF WORK

D2.1 The Work to be done under the Contract shall consist of provision of hired equipment and dump trucks for the period of April 8, 2014 to April 7, 2015.

D2.2 The City shall be the sole judge of what Work will be performed under this contract.

D2.3 The City reserves the right to issue other Bid Opportunities for equipment/dump trucks.

D2.4 The City reserves the right to by-pass a lower Bid pieces of equipment/dump truck, if it is deemed inadequate for the particular job.

D3. DEFINITIONS

D3.1 When used in this Bid Opportunity:

- (a) "**Business Day**" means any Calendar Day, other than a Saturday, Sunday or a Statutory or Civic Holiday;
- (b) "**Submission Deadline**" and "**Time and Date Set for the Final Receipt of Bids**" means the time and date set out in the Bidding Procedures for final receipt of Bids.

D4. CONTRACT ADMINISTRATOR

D4.1 The Contract Administrator is:

Marc Jaeger
Senior Technologist

Telephone No. 204- 986-7409

Facsimile No. 204- 986-5566

D5. CONTRACTOR'S SUPERVISOR

D5.1 Before commencement of Work, the Contractor shall identify his/her designated supervisor and any additional personnel representing the Contractor and their respective roles and responsibilities for the Work.

D6. NOTICES

D6.1 All notices, request, nominations, proposals, consents, approvals, statements, authorizations, documents or other communications required or permitted to be given under the Contract shall be in writing and shall be delivered by hand, facsimile transmission (fax) or by mail.

D6.2 All notices, requests, nominations, proposals, consents, approvals, statements, authorizations, documents or other communications to the City, except as expressly otherwise required in C22.3 or C22.4, or elsewhere in the Contract, shall be sent to the attention of the Contract Administrator.

D6.3 All notices of appeal to the Chief Administrative Officer shall be sent to the following address or facsimile number:

The City of Winnipeg
Chief Administrative Officer Secretariat
Administration Building, 2nd Floor
510 Main Street
Winnipeg MB R3B 1B9
Facsimile No.: (204) 949-1174

- D6.4 All notices, requests, nominations, proposals, consents, approvals, statements, authorizations, documents or other communications required to be submitted or returned to the City Solicitor shall be sent to the following address or facsimile number:

The City of Winnipeg
Corporate Services Department
Legal Services Division
185 King Street, 3rd Floor
Winnipeg MB R3B 1J1
Facsimile No.: (204) 947-9155

SUBMISSIONS

D7. AUTHORITY TO CARRY ON BUSINESS

- D7.1 The Contractor shall be in good standing under The Corporations Act (Manitoba), or properly registered under The Business Names Registration Act (Manitoba), or otherwise properly registered, licensed or permitted by law to carry on business in Manitoba, or if the Contractor does not carry on business in Manitoba, in the jurisdiction where the Contractor does carry on business, throughout the term of the Contract, and shall provide the Contract Administrator with evidence thereof upon request.

D8. WORKERS COMPENSATION

- D8.1 The Contractor shall be registered with the Workers Compensation Board of Manitoba, shall provide and maintain Workers Compensation coverage throughout the term of the Contract, and shall provide the Contract Administrator with evidence thereof upon request. Commencement of Work will not be allowed prior to the confirmation of coverage with the Workers Compensation Board.
- D8.2 For the purpose of this Contract, a Contractor shall be in good standing with workers compensation and will not be deemed a "worker" by the compensation board.

D9. INSURANCE

- D9.1 The Contractor shall provide and maintain the following insurance coverage:
- (a) commercial general liability insurance, in the amount of at least two million dollars (\$2,000,000.00) inclusive, with The City of Winnipeg added as an additional insured; such liability policy to also contain a cross-liability clause, contractual liability, non-owned automobile liability and products and completed operations cover, to remain in place at all times during the performance of the Work;
 - (b) if applicable, Automobile Liability Insurance covering all motor vehicles, owned and operated and used or to be used by the Contractor directly or indirectly in the performance of the Service. The Limit of Liability shall not be less than \$2,000,000 inclusive for loss or damage including personal injuries and death resulting from any one accident or occurrence;
 - (c) Evidence of insurance to reference Bid Opportunity # 141-2014 and if the operations include either underground work, surface work or both. Commercial general liability deductible to be expressly stated on the certificate of insurance and must not exceed \$5,000.00
- D9.2 Contractors (i) not operating licensed equipment with attached apparatus and (ii) not operating unlicensed equipment will be allowed to provide coverage as detailed under D9.1 (b) only;

provided that both conditions are met and that their insurance certificate clearly states that the "Excluding Operation of Attached Machinery Endorsement" does not apply to the operations of the Contractor. (Example: Under MOI Special Risk Extension this would be an SEF 30 Endorsement). All other provisions detailed in clauses D9.3 to D9.8 apply. The deletion of the Commercial General Liability requirement under clause D9.2 is not a recommendation by the City that a Contractor operate without CGL cover.

- D9.3 All policies shall be taken out with insurers licensed to and carry on business in the Province of Manitoba. All policies shall be taken out with insurers licensed to and carry on business in the Province of Manitoba.
- D9.4 Deductibles must be expressly stated on the certificate of insurance and must not exceed \$5,000.00.
- D9.5 The Contractor shall provide the Contract Administrator with a certificate of insurance of each policy at least two (2) Business Days prior to the commencement of any Work on the Site but in no event later than seven (7) Calendar Days from notification of the award of Contract.
- D9.6 The Contractor shall not cancel, materially alter, or cause each policy to lapse without providing at least fifteen (15) Calendar Days prior written notice to the Contract Administrator.
- D9.7 The City shall have the right to alter limits and/or coverage's as reasonably required from time to time during the continuance of this agreement.

SCHEDULE OF WORK

D10. COMMENCEMENT

- D10.1 The Contractor shall not commence any Work until he/she is in receipt of a notice of award from the City authorizing the commencement of the Work.
- D10.2 The Contractor shall not commence any Work on the Site until:
- (a) the Contract Administrator has confirmed receipt and approval of:
 - (i) evidence that the Contractor is in good standing under The Corporations Act (Manitoba), or properly registered under The Business Names Registration Act (Manitoba), or otherwise properly registered, licensed or permitted by law to carry on business in Manitoba;
 - (ii) evidence of the workers compensation coverage specified in D8; and
 - (iii) evidence of the insurance specified in D9.
 - (b) the Contractor has attended a meeting with the Contract Administrator, or the Contract Administrator has waived the requirement for a meeting.
- D10.3 The Contractor must provide the City with their G.S.T. registration number at least 24 hours prior to starting Work. If the G.S.T. registration number is not supplied within 24 hours of Work, then the Contractor will not receive G.S.T. payment for the first 24 hours after the number is received.

D11. DECLARATION BY CONTRACTOR

- D11.1 The Contractor declares that he has submitted his Bid and entered into this Contract with the City in good faith and that to the best of his knowledge no member of Council, or any officer or employee of the City has any pecuniary interest, direct or indirect, in the said Contract, and further that the said Contractor shall forfeit all claims under this Contract for Work done beyond the actual proven expenses of the Contractor if any member of Council, or any officer or employee of the City is at any time interested therein is given or agreed to be given to him and as well shall refund to the City any monies paid to the Contractor by the City under this Contract beyond the actual expenses of the Contractor. The Contractor declares that he has not participated in any collusive scheme or combine in connection with his Bid or Contract.

D12. DAMAGE CLAIMS

- D12.1 The Contractor shall report any event resulting in injury or damage immediately following the occurrence of such event, and the receipt of notice of an action, proceeding, claim or demand alleging or giving notice of injury immediately following receipt thereof, to the City of Winnipeg Claims Branch.
- D12.2 The City shall notify the Contractor of all claims of injury or damage alleged to have been caused by the Contractor or his equipment of which it receives notice.
- D12.3 The City of Winnipeg Claims Branch will investigate all reports or claims of injury or damage reported by the Contractor or of which it has received notice. The Contractor shall co-operate with the Claims Investigator and shall promptly provide the Claims Investigator with all information requested of him to enable the Claims Investigator to determine responsibility for the injury or damage.
- D12.3.1 The Claims Investigator shall notify the Contractor of his decision and where the decision is that the Contractor was responsible, the Contractor shall settle the claim expeditiously

D13. OWNERSHIP OF INFORMATION, CONFIDENTIALITY AND NON DISCLOSURE

- D13.1 The Contract, all deliverables produced or developed, and information provided to or acquired by the Contractor are the property of the City and shall not be appropriated for the Contractors own use, or for the use of any third party.
- D13.2 The Contractor shall not make any public announcements or press releases regarding the Contract, without the prior written authorization of the Contract Administrator.
- D13.3 The following shall be confidential and shall not be disclosed by the Contractor to the media or any member of the public without the prior written authorization of the Contract Administrator;
- (a) information provided to the Contractor by the City or acquired by the Contractor during the course of the Work;
 - (b) the Contract, all deliverables produced or developed; and
 - (c) any statement of fact or opinion regarding any aspect of the Contract.
- D13.4 A Contractor who violates any provision of D13 may be determined to be in breach of Contract.

PART E - SPECIFICATIONS

GENERAL

E1. GENERAL

E1.1 These Specifications shall apply to the Work.

E2. EQUIPMENT AND TRUCK CLASS GROUPINGS

E2.1 Minimum Specifications for Dump Trucks

Spec.	CLASS CODES		
	A1	A4	A7
	Single Axle Dump Truck	Tandem Axle Dump Truck	Semi-Trailer Truck
GVW	10,866 kg (24,000 lbs.)	21,318 kg (47,000 lbs.)	36,287 kg (80,000 lbs.)
<u>Box Size</u>			
Length	3.05 metres (10')	3.70 metres (13')	6.09 metres (20')
Width	2.25 metres (7'3")	2.25 metres (7'3")	2.25 metres (7'3")
<u>Height</u>			
Sides	46 cm (18")	77 cm (30")	92 cm (36")
Sides w/Planks	77 cm (30")	92 cm (36")	122 cm (48")
Hinge	77 cm (30")	107 cm (42")	138 cm (54")
Front	102 cm (40")	117 cm (46")	122 cm (48")

E2.2 Single Axle and Tandem Axle Dump Trucks these trucks may be required to be equipped with the following:

- (a) Light and brake hook-up to facilitate City of Winnipeg trailer hook-ups.
- (b) Combination pintle/ball trailer hitch.
 - (i) Must be .76 metres (2'6") from ground to top of pintle hitch.
 - (ii) Must be .30 metres (1') clearance bottom of box to pintle hitch.
 - (iii) Set back no more than .45 metres (1'6") from end of box to pintle hitch.

E2.3 Rubber-Tired Backhoe Loaders are described by the Class Code in the attached Table:

- (a) These Rubber-Tired Backhoe Loaders are with buckets only no other attachments.
- (b) This equipment is considered to be used in underground work evidence of insurance as stated in D9.1 (c) must be provided.

CLASS CODES		
C2	C3	C4
50-80 Net H.P. 16'+ Over Depth Rubber Tired Backhoe With Extend-A-Hoe	81-99 Net H.P. 16'+ Over Depth Rubber Tired Backhoe	100+ Net H.P. 17'+ Over Depth Rubber Tired Backhoe
Case 580 D, E,K,L Case 580 SK,SL,SM	Case 590 SL Case 680 K,L	CASE 590 SM Case 780
CAT 416 CAT 426	420 D, E CAT 426B,C,IT CAT 428B CAT 436	CAT 446 CAT 430E
John Deere 310 C,D,SE John Deere 410C	310 SG John Deere 410D, G John Deere 510 C,D John Deere 610C	John Deere 710 B,C
Ford 555 B,C,D Ford 655 A,C,D	NEW HOLLAND 575 E	Ford 755B
---	JCB 214, 214S JCB 215S JCB 217, 217S JCB 1400B	---

E2.4 Hydraulic Excavators as described below:

- (a) D1 Rubber-Tired (Truck-Type) Carrier-Mounted
 Minimum reach 17 ft.
 Must be equipped with remote travel control
- (b) D2 Rubber-Tired Single Engine - 4 Wheel-Drive (Drott 40 Cruz-Air Type)
 Minimum reach 17 ft.
- (c) This equipment is considered to be used in underground work evidence of insurance as stated in D9.1 (c) must be provided.

E2.5 Hydraulic Excavator, Tracked as described below:

- (a) E1 Minimum rated bucket capacity 1 1/4 cu. yd.
 Minimum operating weight 49,600 lbs.
 Minimum reach 18 ft 6 in. with 8 ft. level bottom
- (b) E2 Minimum rated bucket capacity 2 cu. yd.
 Minimum operating weight 74,900 lbs.
 Minimum reach 23 ft. 4 in. with 8 ft. level bottom.
- (c) E3 Weight under 45,000 lbs. List weight on construction bid sheet Minimum reach 18'
 Minimum digging depth of 16'
- (d) This equipment is considered to be used in underground work evidence of insurance as stated in D9.1 (c) must be provided.

E3. STREET SWEEPERS

- E3.1 All street sweepers must be able to contain a water supply with no leakage, and all water spray systems must work properly, plus broom pattern must meet City of Winnipeg standards or unit will not be allowed to work.
- E3.2 The Contract Administrator shall be the sole judge as to when spring cleanup is completed.
- E3.3 Street Sweepers, F5, F7 as described below:
Minimum 3 cu. yd. capacity
Minimum 10 ft. sweeping width
Minimum 4 ft. 6 in. pick up broom width
- E3.4 Street Sweeping - Spring Cleanup and Fall Leaf Pickup
(a) Classes F5, F7 double gutter broom high dump street sweepers
- E3.5 Street Sweeping - Regular
(b) Classes are F5 and F7, double gutter broom, high dump.
- E3.6 Street Sweeping - Central Services
Please note that Central Services sweeps all types of granular material and some rough road surfaces. Units Bid must have hydraulic down pressure on pick up broom in order to keep a constant ground pressure, plus no restrictions to prevent lowering back pick-up brooms.
- E3.7 The street sweeper Class Codes are as follows:
(a) F5 4 Wheel Truck Type (EAGLE TYPE) Double Gutter Broom High Dump with independent motor to drive brooms and conveyor
(b) F7 Hydrostatic Drive Double Gutter Broom 3-Wheel High Dump
- E3.8 Sidewalk Sweepers as per Class Code noted below:
(c) G3 Minimum 35 Horsepower/Minimum Sweeping width 48"/Hi-Dump Model
(d) G5 Minimum 55 Horsepower/Minimum Sweeping width 60"/Hi-Dump Model.
- E3.9 Rates quoted shall be inclusive of:
(a) Suitable means of transporting sweeper(s) to job sites.
(b) Ramps or other suitable devices for climbing curbs when required.
- E3.10 Boulevard Sweepers must be a Class Code G7 as noted below:
(a) Agriculture type tractor hydro static drive minimum 32 horsepower. Rear sweeper broom. Minimum 6' (feet) sweeper broom.
(b) Will be required to work in close proximity to buildings, trees, and sign poles thus tractors can be no more 6' wide maximum.
(c) Must meet safety specs. E8.
(d) Back broom must be minimum 6' (feet) wide
Must be hydraulic controlled to angle left or right from operators seat.
- E3.11 Crawler Loaders as noted by the Class Code below:
(a) H1 Less than 70.0 Drawbar Horsepower
(b) H2 70.0 to 88.9 Drawbar Horsepower
(c) H3 89.0 to 117.9 Drawbar Horsepower
(d) H4 118.0 to 142.9 Drawbar Horsepower

- (e) H5 143.0 to 174.9 Drawbar Horsepower
- (f) H6 175.0 to 209.9 Drawbar Horsepower
- (g) H7 210.0 to 249.9 Drawbar Horsepower
- (h) H8 250.0 to 294.9 Drawbar Horsepower
- (i) H9 295.0 & over Drawbar Horsepower

E3.12 Crawler Tractors/Dozers as noted by the Class Code below:

- (j) I1 Less than 70.0 Drawbar Horsepower
- (k) I2 70.0 to 88.9 Drawbar Horsepower
- (l) I3 89.0 to 117.9 Drawbar Horsepower
- (m) I4 118.0 to 142.9 Drawbar Horsepower
- (n) I5 143.0 to 174.9 Drawbar Horsepower
- (o) I6 175.0 to 209.9 Drawbar Horsepower
- (p) I7 210.0 to 249.9 Drawbar Horsepower
- (q) I8 250.0 to 294.9 Drawbar Horsepower
- (r) I9 295.0 & over Drawbar Horsepower

E3.13 All crawler tractors shall be equipped with R.O.P.S. cab or canopy and back up alarms, and equipped with an amber oscillating or strobe beacon.

E3.14 Rubber-Tired Front End Loaders as noted below:

- (a) J2 Rubber-Tired - 4-Wheel Drive Loader
SAE Net Horsepower Minimum 75 H.P.
Operating Weight 15,000 lbs. - 20,000 lbs.
Bucket Size 1 ½ - 2 ¼ cu. yd.
- (b) J3 Rubber-Tired - 4-Wheel Drive Loader
SAE Net Horsepower Minimum 100 H.P.
Operating Weight 21,000 lbs. - 29,000 lbs.
Bucket Size 2 ¼ - 3 cu. yd.
- (c) J5 Rubber-Tired - 4-Wheel Drive Loader
SAE Net Horsepower Minimum 160 H.P.
Operating Weight 31,000 lbs. - 41,000 lbs.
Minimum Bucket Width 8'9" (2.7m).
- (d) J6 Rubber-Tired - 4-Wheel Drive Loader
SAE Net Horsepower Minimum 200 H.P.
Operating Weight 38,000 lbs. - 45,000 lbs.
Bucket Size 4 1/4 & over cu. yd.
- (e) J7 Rubber-Tired - 4-Wheel Drive Loader
SAE Net Horsepower Minimum 250 H.P.
Operating Weight 45,000 lbs. & over
Bucket Size 5 cu. yd. & over

E3.15 All units quoted that are assigned Work in a pit or quarry type operation must have an SAE approved ROPS cab or canopy, and have back-up alarms.

E3.16 Motor Graders as noted below:

- (a) K3 Minimum 125 Flywheel Horsepower
- (b) K4 Minimum 140 Flywheel Horsepower
- (c) K5 Minimum 160 Flywheel Horsepower
- (d) K6 180+ Horsepower

E3.17 Truck/Air Compressor Combination Class Code L1 as noted below:

- (a) The above combination unit will be utilized in joint sealing operation on City streets and lanes, and other areas as may be directed. The purpose of this unit is to:
 - (i) provide compressed air for City crews engaged in cleaning pavement joints and cracks prior to sealing;
 - (ii) to transport (by means of towing) a joint sealing machine to job locations as directed; and
 - (iii) to transport pails/drums of joint sealing compound to job locations as directed.
- (b) Air Compressor shall be:
 - (i) deck or box mounted to a suitably-sized truck.
 - (ii) minimum 125 CFM and capable of continuous duty. Air supply must be oil free and equipped with a moisture separator. Air supply shall be routed to the front, centre, of the carrier truck in a manner that the air supply is easily accessible.
 - (iii) Air hose/pipe shall be equipped with "Thor" type couplings.
- (c) Truck shall be:
 - (i) have a gross vehicle rating capable of carrying a minimum 125 CFM air compressor (approximate weight 3500 lbs./1590 kg) twenty-five - 50 lb./23 kg pails of joint sealing compound, two - 100 lb./46 kg propane tanks, trailer tongue weight of approximately 200 lbs./91 kg and 2 City of Winnipeg personnel.
 - (ii) The deck shall have brackets to secure propane tanks in an upright position.
 - (iii) The deck shall be of a size to accommodate, in addition to the above mentioned compressor, up to twenty-five 50 lb./23 kg pails of joint sealing compound. Dimension of pails approximately 12" diameter by 18" in height. Height of deck shall be approximately 44" from ground level.
 - (iv) Adequate sides and tailgate or other suitable means of containing the aforementioned pails shall be provided. If the compressor is mounted in a location on the deck that restricts rear loading of the above mentioned pails, truck sides shall be easily lowered or removable to facilitate easy loading.
 - (v) equipped with a rear-mounted pintle hitch capable of towing a trailer mounted joint sealing machine weighing approximately 6500 lbs./2950 kg.
 - (vi) The hitch shall be mounted at a height of 24" from ground level.
 - (vii) equipped with a female trailer electrical connector compatible with City of Winnipeg male connectors. Should the truck be equipped with a voltage higher than the 12 volt system used by the City, the truck owner will be responsible for all costs incurred to make both systems compatible. This must also allow for using different City joint sealer machines.

E3.18 Rubber-Tired Backhoe Loader/Hydraulic Pavement Breaker (Hoe-Mounted) Class Code M1 as noted below:

- (a) You must bid your Rubber-Tired Backhoe with one rate as an M1 and your breaker with another rate as an M1A and the two rates will be combined according to formula in paragraph B13.6
- (b) The above combination to be utilized for breaking pavement and/or frost on City of Winnipeg construction sites as directed.
- (c) Backhoe shall be :
 - (i) a minimum C2 size for the M1 category.
 - (ii) The hydraulic pump output shall be of sufficient volume and pressure to operate the attached breaker at the optimum performance level as specified by the manufacturer of the breaker.
 - (iii) The hydraulic supply (hoses) to the breaker shall be fitted with "quick" couplers to facilitate easy bucket/breaker changeover.
- (d) Pavement-Breaker shall be:

- (i) have a minimum rating of 700 ft. lbs. impact per blow, and 600 blows per minute.
 - (ii) pin-mounted to the backhoe and equipped with hydraulic "quick" couplers and be capable of rotating 90 degrees to the left and right of centre.
 - (e) All waiting time for this class shall be paid at the backhoe rate.
 - (f) This equipment is considered to be used in underground work evidence of insurance as stated in D9.1 (c) must be provided.
- E3.19 Rubber-Tired Loader/Backhoe Class Code M2 Hydraulic Pavement Breaker as equipped:
 - (a) Backhoe
 - (i) Hydraulic pump output shall be of sufficient volume and pressure to operate the attached breaker at the optimum performance level as specified by the manufacturer of the breaker.
 - (ii) Hydraulic supply (hoses) to breaker shall be fitted with "quick" couplers to facilitate easy bucket/breaker changeover.
 - (b) Pavement-Breaker
 - (i) The breaker shall be pinmounted to the backhoe and equipped with hydraulic "quick" couplers.
 - (ii) The breaker shall have a minimum rating of 1300 ft./lbs. and 550 blows/min.
- E3.20 Excavator Hydraulic Breaker Class Code M3 as equipped:
 - (a) Excavator
 - (i) Hydraulic pump output shall be of sufficient volume and pressure to operate the attached breaker at the optimum performance level as specified by the manufacturer of the breaker.
 - (b) Pavement-Breaker
 - (i) The breaker shall be pin mounted to the excavator. The breaker shall have a minimum rating of 2000 ft./lbs. and 450 blows/min.
- E3.21 Hi-Pressure Sewer Cleaner/and Closed Circuit Class Code N1, N2 Television Equipment With Flushing/Cleaning Equipment
 - (a) The above shall provide for:
 - (i) The cleaning of sewers with high pressure water jet equipment.
 - (ii) Television inspection of sewers and associated documentation. In the event that sewer debris is impeding the ability to properly televise the sewer, the company hired to do the televising shall be given the option of the cleaning/flushing the sewer even if is cheaper for cleaning from a N1 Bid. It is not feasible to call out another contractor just for cleaning and then call the television equipment back.
- E3.22 Hi-Pressure Sewer Cleaning Equipment –Class Code N1
 - (a) Shall provide a minimum operating pressure of 900 psi. Pressure shall be variable upwards, but not to exceed 1600 psi. If requested, any material loosened from the sewer shall be removed and hauled to an approved disposal site by the Contractor. Subject to supplementary regulation, including but not limited to back flowpreventing, water required for the cleaning operation may be obtained from a designated City water hydrant at no charge. Clearance for designated hydrant must first be arranged with Water Works Department.
- E3.23 Closed Circuit Television – Class Code N2
 - (a) Shall provide a television image of the interior of designated sewers for observation by a City representative on site. The image shall be sufficiently clear so that the condition of the sewer and appurtenances can be determined and assessed.
 - (b) Shall provide, when requested, photographs of all locations as specified by a City representative.

- (c) Shall provide written reports, suitable to the City representative as to form and detail.
- (d) Measurements shall be provided in feet and/or metres as requested, and to be accurate to plus or minus 2 feet (.6 metres).
- (e) Shall provide complete videotapes of all sewers inspected; tapes shall become the property of the City. Tapes must be compatible with the VHS format of video reproduction.
- (f) The Contractor shall be responsible for providing proper signing and barricades as defined in the current edition of the Manual of Temporary Traffic Control in work areas on City streets and shall comply with all applicable By-laws and Regulations.

E3.24 Catch Basin Cleaner – Class Code N3

- (a) Shall provide for the cleaning of debris from catch basins, catch basin connections from the curb inlet box, culverts, manholes, water valve boxes and valve pits, and any other related Work as may be required.
- (b) Shall provide sufficient length of hose and attachments, and have the capability of drawing up debris from manhole depths of up to twenty feet.
- (c) Shall provide a minimum debris storage capacity of thirteen cubic yards. Collected debris material will be disposed of as directed by the City Supervisor, Foreman, or other official of a user group.
- (d) The Contractor shall be responsible for providing proper signing and barricades as defined in the current edition of the Manual of Temporary Traffic Control in work areas on City streets and shall comply with all applicable By-laws and Regulations.

E3.25 Class N3D Soft Dig – Hydro Vac Units

- (a) The Contractor shall provide the following items on the N4 Hydro Vac Units:
 - (i) Neoprene on suction nozzle;
 - (ii) Lance to have isolating tip;
 - (iii) 1200 PSI on Lance;
 - (iv) 120 Degree Water Temperature on Lance;
 - (v) 3000 C.F.M. Air Suction.
- (b) Contractor shall have the ability and clearance to work independently to expose underground utilities while working within parameters set by Gas, Hydro, Cable Company, Water and Sewer.
- (c) This equipment is considered to be used in underground work evidence of insurance as stated in D9.1 (c) must be provided.

E3.26 Water Distributor

- (a) The water distributor is fed by gravity or by pump as shown below:
 - (01) 1500 – 2000 Imperial Gallons Single Axle Water Distributor
 - 1) 01 Gravity Flow - 1,000 - 2,000 Imperial Gallons.
 - 2) 01A Pumped through Main Spray Bar- 1,000 - 2,000 Imp. Gallons.
 - 3) 01B Pumped through 1.5" x 25' hose- 1,000 - 2,000 Imp. Gallons
 - (02) 2200 – 3000 Imperial Gallons Tandem Axle Water Distributor
 - 1) 02 Gravity Flow - 2,200 - 3,000 Imperial Gallons.
 - 2) 02A Pumped through Main Spray Bar- 2,200 - 3,000 Imp. Gallons.
 - 3) 02B Pumped through 1.5" x 25' hose- 2,200 - 3,000 Imps. Gallons.
 - 4) 02C Flusher with Adjustable Swivel Heads 2200 - 3000 Imp. Gallons.
 - (03) 3200 – 4000 Imperial Gallons Trailer Mounted Water Distributor
 - 1) 03 Gravity Flow - 3,200 - 4,000 Imperial Gallons.
 - 2) 03A Pumped through Main Spray Bar- 3,200 - 4,000 Imp. Gallons.
 - 3) 03B Pumped through 1.5" x 25' hose- 3,200 - 4,000 Imps. Gallons.
 - 4) 03C Flusher with Adjustable Swivel Heads 3200 - 4000 Imp. Gallons.
 - (04) All water distributors must be equipped with an air gap system located on the water supply outlet line as a backflow prevention.

- (05) Spray bar must be minimum of 3" diameter and holes must be spaced to provide an even coverage and spray must overlap to avoid dry gaps on roadway surface.
- (06) Spray bar shall be full width of truck with provision to add 2' extension to the right hand side of spray bar (passenger side).
- (07) Shut off valve shall be controlled from cab.

E3.27 Roll-off Trucks with the hook and winch style body compatible with the ANSI Type H roll-off bins (AKA: dead lift roll-offs). Trucks must be capable of loading and transporting bins with a length of at least 7 m (23ft.), in sizes from 20 yds. to 40 yds.

E4. EQUIPMENT AND TRUCK RELIABILITY

E4.1 At the sole discretion of the Street Maintenance Division, equipment or trucks which show a history of breakdowns and/or not reporting for Work or of being substituted for will be suspended and no further attempts will be made to hire the said piece of equipment or truck until it has been re-evaluated by the Street Maintenance Division. The Contractor shall produce copies of Work orders indicating that the equipment or truck has been repaired or that other problems have been rectified. Also all equipment/trucks must comply with the specifications and safety requirements in this Bid Opportunity or the unit will not be used.

E5. OPERATOR'S COMPETENCE AND PERFORMANCE

E5.1 The Contractor's operator shall maintain all equipment/trucks in good working order and shall perform all obligations expressed and implied in this Bid Opportunity in a good, safe and workmanlike manner.

Where in the opinion of the City supervisor or foreman, an operator fails to meet the obligations expressed or implied in this Bid Opportunity and without limiting the generality of the foregoing, the operator is:

- (a) unqualified, or
- (b) operating in an unsafe manner, or
- (c) not performing a satisfactory amount of Work,
- (d) engaged in activity outside the City's interest.

The equipment/truck and operator may be dismissed immediately and shall not be re-engaged until such time as the inadequacies that resulted in the dismissal have been remedied to the sole satisfaction of the Contract Administrator.

E6. SUSPENSION AND REMOVAL FROM CALLOUT LISTS

E6.1 Suspension or removal of equipment and/or operators from the callout lists may be made by the Contract Administrator, at his sole discretion, for any failure on the part of the Contractor to meet any of the obligations in this Bid Opportunity and shall include, but shall not be limited to:

- (a) Failure to supply equipment/trucks on two separate phone calls and or equipment/trucks found working elsewhere.
- (b) Failure to supply an Operator/Driver with the appropriate driver's license for said piece of equipment/truck
- (c) Equipment/truck mechanical condition;
- (d) Operator's attitude, ability or actions;
- (e) Failure to report to an assigned work site;
- (f) Failure to report to the work site at the assigned time;
- (g) Working without being assigned by the Equipment Co-ordinator;
- (h) Failure to bring equipment in for inspection, when requested to do so;

- (i) Failure to properly complete Work Tickets;
- (j) Low productivity (at sole determination of the City Foreman or Supervisor);
- (k) Failure to report to the City of Winnipeg Claims Branch as required in D12;
- (l) Failure to co-operate with the Claims Investigator as required in D12;
- (m) Failure to settle any claim as required in D12;
- (n) Failure to provide the Equipment Dispatch Office of the Street Maintenance Division with evidence of insurance as required in D9.1;
- (o) Failure to supply or provide safety attire to their employees as established by the city;
- (p) Equipment/trucks fail to meet visibility and lighting standards.
- (q) Engaged in activities outside of the City's interest.

E6.2 After suspension, the Contractor will be requested to explain the circumstances that caused the suspension. The Contract Administrator at his discretion, may request that (but not limited to):

- (a) The operator be evaluated by City staff;
- (b) The equipment/truck be repaired and inspected after repair; and/or
- (c) The equipment/truck and operator be monitored in the field.

E6.3 There will be no financial compensation for suspension or removal from the call out list.

E6.4 If the Contractor should abandon the Work or if he were adjudged to be bankrupt or make a general assignment for the benefit of his creditors or if a receiver or liquidator should be appointed in respect of his assets or if he fails to comply with an order of the Contract Administrator given pursuant to any of the provisions of this Bid Opportunity or if he should fail to make prompt payment of wages, or accounts for the purchase or rental of material or plant or disregard by-laws and statutory regulations or if he commits any other breach of the provisions of this Bid Opportunity, which in the opinion of the Contract Administrator indicates an unwillingness or inability upon the part of the Contractor to carry out the terms thereof, the Contract Administrator may notify the Contractor to discontinue all Work or any part thereof, under this Bid Opportunity, by a written notice to be served upon the Contractor. Such notice being given, the Contractor shall forthwith discontinue the Work or such part thereof as the Contract Administrator shall designate.

E7. OWNERS OF EQUIPMENT/TRUCKS AND THEIR EMPLOYEES

E7.1 The Contractor, owner, owner/operator and/or operator of the equipment supplied under this Bid Opportunity shall be considered an independent contractor who will work under the direction of a City employee and it is acknowledged and agreed that such person shall be a servant of the owner of the equipment/trucks and shall not be considered an employee of the City of Winnipeg.

E8. SAFETY REQUIREMENTS

E8.1 No person under the age of 18 may operate hired equipment or trucks for The City of Winnipeg.

E8.2 All equipment shall be equipped with lighting to meet or exceed the requirements of the Public Works Department Equipment Lighting Visibility Standard as per Appendix C and regulations passed there under. Dump trucks, dump trailers or trucks mounted with other apparatus, to be equipped with strobe or revolving beacon.

E8.3 All equipment and trucks Bid in this Bid Opportunity shall be equipped with an operating back-up alarm.

E8.4 Contractors (and their employees) hired by the City shall familiarize themselves with and abide by any and all requirements, with regard to personal protective equipment and all standards pertinent to the supply and safe operation of equipment, as required by any and all applicable

Federal, Provincial and Civic By-Laws, Acts, orders and regulations in force at the time this Bid Opportunity is accepted, or which may subsequently be enacted.

- E8.5 Without limiting the foregoing, all operators shall have and use appropriate safety head wear, footwear, safety vests and hearing protection, and must abide by the manual of temporary traffic control of the City of Winnipeg, at all times. Additional personal protective equipment is required when working during periods of low visibility, with the minimum standard being CSA Class 3 safety apparel (Refer to Appendix 'D' for details.) Reflectorized wrist and ankle cuff bands can be used to meet this requirement.
- E8.6 All equipment working or which travels under 40 km per hour must have a safety triangle mounted at rear of their piece of equipment or truck.
- E8.7 As outlined in the Public Works Department's Equipment Lighting and Visibility Requirements document (included in this bid-opportunity package) all hired equipment and trucks must have an amber beacon mounted and visible from four directions. Blue beacons or strobes can only be used during winter snow removal operations and must be removed or de-energized when the vehicle is not being used in snow removal operations. As a reminder to all contractors supplying trucks and equipment to the City of Winnipeg, an application for a beacon permit must be filed with Manitoba Public Insurance Vehicles Standards and Inspections at Box 6300, 1981 Plessis Road, Building B, Winnipeg, Manitoba, R3c 4A4, or fax to (204) 954-5319. A copy of the application form is included in the Public Works Department's Equipment Lighting and Visibility Requirements document. The permit must be kept in the vehicle while working for the City of Winnipeg. If a permit is not obtained you may receive a ticket if inspected.

E9. EQUIPMENT IDENTIFICATION

- E9.1 All equipment and trucks hired by the City via this Bid Opportunity must be clearly labelled indicating Contractor's name and unit number as indicated in their Bid Submission.
- E9.2 Letters and numbers used for identification purposes must be a minimum of four inches (4"), ten millimetres (10 mm) in height and positioned in such a manner as to be clearly visible when standing at either side of the machine. Equipment or trucks will not be allowed to work until it is properly identified.
- E9.3 It is absolutely imperative that unit numbers on equipment and trucks and indicated on Work Tickets (outlined in Provision 20 below) exactly match those numbers listed on Form B: Prices Bid Submissions. Failure to do so will result in computer rejection of the timekeeping entry associated with a piece of equipment or truck number referenced in error, and an associated delay in payment.
- E9.4 The City will institute a sticker identification system for some or all of the equipment supplied in this Bid Opportunity.

E10. WORK TICKETS

- E10.1 The Contractor and/or the Contractor's employees operating hired equipment for the City shall complete Work Tickets, supplied by the City, at the end of each Work shift or when Work is completed or otherwise terminated. Work Tickets must be completed so as to indicate date, location of Work, Contractor's name, supplier number, license number if applicable, equipment unit number, plus city issued number, description of equipment, start and finish time using 24 hour clock, operating hours, operator's signature and operator's printed name. The Work Tickets must be signed by the project Foreman or designate and shall be distributed as indicated on the bottom left corner of the ticket.
- E10.2 Failure to properly complete the above-mentioned Work Tickets will result in delay of payment for the Work detailed, until such time as the ticket is corrected and re-submitted.
- E10.3 Continued failure to properly complete Work Tickets may result in the Contractor's equipment being moved to the bottom of applicable hiring list or suspension from that list.

E11. SUBSTITUTIONS, REPLACEMENTS AND AVAILABILITY

- E11.1 In the event equipment/trucks as quoted are not available when called, due to breakdown or other circumstances resulting in short-term non-availability of the equipment, the City may allow substitution of such equipment providing:
- (a) the substitute equipment/trucks are, in the opinion of the Contract Administrator, at least equal in all respects to the equipment for which it is being substituted, and is owned by the Contractor; and
 - (b) the substitution will be allowed up to a maximum of one week. If in a period of 90 working days the quoted piece of equipment is not available on two separate occasions the unit may be deemed unreliable and may be removed from the callout list.
- E11.2 The total number of units (within a class) from a Contractor working for the City shall not, due to such substitutions, exceed the total number of units originally quoted by that Bidder.
- E11.3 All substitutions must be approved by the Equipment Dispatch Office of the Street Maintenance Division prior to such equipment commencing Work.
- E11.4 If the Contractor sells or otherwise disposes of a piece of equipment/truck detailed on the callout list, he will be allowed to replace that piece of equipment providing the replacement is, in the opinion of the Contract Administrator, at least equal in all respects to the equipment it is replacing and provided the piece of equipment being replaced has worked under the terms of and as a result of this Bid Opportunity, for a minimum of five (5) working days in the current construction season.
- E11.5 All requests to allow replacement of quoted equipment which has been disposed of shall be submitted in writing to:
- Contract Administrator
Street Maintenance Division
104-1155 Pacific Avenue
Winnipeg, MB R3E 3P1
- E11.6 If a piece of equipment/truck on the hiring list is used to replace another piece of equipment which is also listed, but has been disposed of, the original position of the replacement piece of equipment/truck will be forfeited in making the replacement.
- E11.7 The forfeited position is subject to review, at the written request of the Contractor affected, by the Contract Administrator. The decision resulting from the review by the Contract Administrator shall be final.
- E11.8 If a substitute or replacement piece of equipment would, by virtue of its specifications, normally be listed in an equipment class larger than that in which the equipment it is replacing was listed, the substitute or replacement equipment shall be listed in and hired from the same class and position as the unit it is replacing, as though no substitution or replacement had occurred.
- E11.9 Similarly, should a piece of equipment of at least like-size, not negatively affected by the equipment age provision B13.4, be substituted for or replace a piece of equipment which is negatively affected by the age provision, the substitute or replacement shall be listed in the same position as that which it is replacing.
- E11.10 The Contract Administrator reserves the right, at any time, at his discretion, to ask for proof that a unit quoted is in fact owned or leased by the Contractor. This proof may be by means of physical inspection of the equipment or by submission of documentation as deemed appropriate by the City.
- E11.11 In the event such proof is not produced, the equipment in question may be removed from the callout list.

E12. WITHDRAWAL OF EQUIPMENT/TRUCKS PRIOR TO LAYOFF

- E12.1 Should a piece of equipment/truck **not be supplied after two separate call outs** or be withdrawn from operation prior to layoff without permission of the City, no further attempt shall be made by the City to employ equipment from the Contractor involved until an explanation indicating a delay beyond the reasonable control of the contractor has been provided in writing by the Contractor.
- E12.2 If the aforesaid written explanation indicates that the withdrawal is for a reason beyond the control of the contractor, the City may, but shall not be obliged to, rehire the Contractor's equipment.

E13. RE-ARRANGEMENT ("BUMPING") OF HIRED EQUIPMENT AND TRUCKS

- E13.1 In the event that re-arrangement or bumping of hired equipment is required in order to maintain proper order in accordance with a particular hiring list, such re-arrangements shall be made for the first starting hour of the shift on the first Monday of each week except where, in the opinion of the Contract Administrator, such rearrangement would not be in the best interest of the City. Sunday night start is considered Monday first shift.
- E13.2 In the event that re-arrangement or bumping of hired truck(s) is required in order to maintain proper order in accordance with a particular hiring list, such re-arrangements shall be made at the beginning of the next shift, except where, in the opinion of the Contract Administrator, such re-arrangement would not be in the best interest of the City.

E14. CONTRACTOR'S OFFICE AND PHONE NUMBERS

- E14.1 Each Contractor who has quoted more than three machines or trucks shall maintain, during normal working hours, an office staffed by at least one competent person. If the person answering cannot give a firm commitment, the City will consider that the equipment/truck is not available and will go to the next on the list. However, the equipment/trucks shall be hired in its regular slot if the City is notified by the Contractor of a firm commitment prior to filling its requirements.
- E14.2 All equipment operators/truck drivers must have a cell phone. Numbers are to be left with Area Foreman upon reporting for Work.

E15. SPECIALIZED EQUIPMENT, TRUCKS AND DUMP TRUCKS

- E15.1 Equipment/trucks/dump trucks of a specialized nature or possessing specialized attachments, within a class, may be hired before a unit within the same class with a lower quoted rate, provided such use is deemed beneficial to a given project by the Contract Administrator.

E16. PAYMENT FOR RIPPERS AND LOW BED TRAILERS

- E16.1 Payment for frost rippers and low bed trailers shall be at the following rate:
- (a) Frost Ripper: used with backhoes in (Class Code C) \$2.63 per actual hour used.
 - (b) Frost Ripper: used with excavators in (Class Codes D, E) \$4.73 per actual hour used.
 - (c) Frost Ripper: used with crawler excavators in (Class H & I) \$4.73 per hour for entire shift when specifically requested.
 - (d) Low bed moves for class H1-H3 and I1-I4 are \$187.92 per move.
 - (e) Low bed moves for class E1,E2,H4 to H9 and I5-I9 are \$248.40 per move
 - (f) Low bed moves for class E3, W1R are \$150.00 per move.
 - (g) Equipment being transported by low bed will not be paid while in transit. Unless otherwise approved by the Contract Administrator, the low bed trailer rates will not apply where:

- (a) Due to but not limited to, equipment breakdown, a piece of equipment has to be transported from the job site prior to lay off or is not available to continue working, and is substituted by or replaced with another piece of equipment from the same equipment supplier, no payment will be made for a low bed trailer used for transporting to the job site the substitute or replacement piece of equipment. Likewise, for a low bed trailer used for transporting from the job, site both the original piece of equipment working and the substitute or replacement piece of equipment, payment will be made for one move only.

E17. RATE ADJUSTMENTS – EXTREME FUEL COST FLUCTUATIONS

- E17.1 The Contract Administrator will undertake periodic reviews of the cost of fuel based on the pump price charged to the Streets Maintenance Division by the City's Fleet Management Agency.

On August 1, 2013 the fuel prices will be reviewed for the period from April 8, 2013 to August 1, 2013 and a rate adjustment will be determined based on equipment fuel consumption. This rate adjustment will only reflect the portion of any fuel price increase or decrease in excess of three (3) per cent for this time period and will be effective as of August 12, 2012 and continuing until December 1, 2012.

On December 1, 2013 the fuel prices will again be reviewed for the period from August 1, 2013 to December 1, 2013 and a further rate adjustment will be considered at this time. This rate adjustment will only reflect the portion of any fuel price increase or decrease in excess of three (3) per cent for this time period and will be effective as of December 16, 2013 and continuing until April 7, 2014.

E18. PRIME CONTRACTOR – THE WORKPLACE SAFETY AND HEALTH ACT (MANITOBA)

- E18.1 The Contractor shall be the Prime Contractor and shall serve as, and have the duties of the Prime Contractor in accordance with The Workplace Safety and Health Act (Manitoba).

E19. PAYMENT SCHEDULE

- E19.1 Payment for hourly hired equipment and trucks shall be processed through the City of Winnipeg Hired Hourly Payroll system. Payment shall be made bi-weekly subject to, but not limited to, proper documentation of Work Tickets by the Contractor, the callout system being used and the correct equipment or trucks responding to callout. All payments are subject to the approval of the Contract Administrator.

E20. DUPLICATION OF MAKE, MODEL AND SERIAL NUMBER

- E20.1 If two or more Contractors Bid the identical machine, the Contract Administrator shall determine which bid, if any, he shall accept. If one of the Bids is accepted for that equipment, all other Bids shall be rejected.
- E20.2 If a Contractor uses a machine that was not Bid by the Contractor, the Contract Administrator shall take whatever considered appropriate action, including but not limited to, suspending all equipment quoted by the Contractor.
- E20.3 Make, Model, Unit, and Serial Number to match all equipment and a copy of the vehicle registration must be submitted to match serial number and plate numbers for trucks before any hiring will be done.

E21. WORKING MORE THAN ONE SHIFT/DAY

- E21.1 The lowest priced equipment in each "class" will be called first for each shift.

E22. EQUIPMENT CO-ORDINATOR

- E22.1 The Equipment Coordinator of the Street Maintenance Division is responsible for controlling and administering the day-to-day operation of the system for hiring construction equipment and trucks. The Equipment Co-ordinator performs the following major functions:
- (a) Hiring and assignment of all construction season equipment and trucks;
 - (b) Re-assignment of equipment/trucks;
 - (c) Maintenance of callout lists;
 - (d) Maintenance of records with respect to hired equipment; and
 - (e) Scrutiny of equipment and concerns.

E23. RESPECTFUL WORKPLACE

- E23.1 The City is committed to implementing and enforcing the Respectful Workplace Administrative Directive, which was approved by the Chief Administrative Officer in February 2002. The City recognizes its responsibility to build and maintain a respectful workplace where all employees enjoy an environment free of behaviours such as unlawful discrimination, harassment, disruptive workplace conflict, disrespectful behaviour and violence in the workplace. Harassment based on race, national or ethnic origin, colour, religion, age, sex, marital status, physical or mental disability, and/or sexual orientation is prohibited.
- E23.2 The City recognizes that disruptive workplace conflicts and disrespectful behaviour can jeopardize an individual's dignity and well-being and/or undermine Work relationships and productivity. The City commits to providing a workplace upon the principle of fair and respectful treatment in order to minimize these conflicts.
- E23.3 In pursuance with the principles of the Directive, the Contractor shall fully comply with the Respective Workplace Administrative Directive and ensure that all persons he employs or retains to perform Work pursuant to the terms of this Bid Opportunity comply with the Directive and behaves respectfully to both members of the public and to employees of the City, failing which the City has the right to investigate and instruct the Contractor to replace any person not behaving respectfully, upon written notice to the Contractor, and the Contractor shall comply with the instruction. The Contractor shall not re-employ or re-retain any person that the City has instructed him to replace for the purpose of performing any other or further Work on this Bid Opportunity.
- E23.4 Should a subsequent situation with respect to lack respectful behaviour occur, the Contract Administrator may remove the Contractor from the callout list on an interim basis or for the balance of the terms of the Bid Opportunity and may recommend to the Chief Administrative Officer that the Contractor be debarred and suspended in accordance with the Materials Management Policy.

E24. RESOLUTION OF DISPUTES

- E24.1 Should a dispute arise with respect to application of the provisions of this Bid Opportunity, the Contract Administrator shall investigate and rule on the dispute and the decision of the Contract Administrator shall be final.

E25. WATER AND SEWER EXCAVATION WORK

- E25.1 The City will only engage excavation contractors to undertake water and sewer excavations that are registered with the Workplace Safety and Health Division, of the Department of Labour, Province of Manitoba. (Workplace Safety and Health Act 210, Manitoba Regulation 189/85, Section 107(1)). To become registered, phone 945-6848.

E26. DRIVER'S LICENSE FOR HIRED HOURLY TRUCKS AND EQUIPMENT

E26.1 The City requires that all Owner's and Contractor's ensure all Drivers and Operators have the appropriate drivers license for all Hired Hourly Trucks and Equipment supplied to the City.

E27. BASIS FOR HIRING AND LAYOFF

E27.1 Trucks and equipment in each class will be hired and laid off on the basis of the quoted hourly rental rate, i.e.: the equipment or truck with the lowest quoted hourly rental rate in each class will be hired first and laid off last, subject to the other provisions of this Specification.

E27.2 Orders pertaining to the hiring and laying off of trucks and equipment issued by the Equipment Dispatch Office of the Streets Maintenance Division shall supersede any orders which may have been issued by a Supervisor, Foreman or other official of a User group

Template Version: S320131129 - S LR

APPENDIX A

CW 518-2000 03

**CITY OF WINNIPEG
 PUBLIC WORKS**

IF SHIFT
 WORKED IS
 NIGHT SHIFT
 ACTUAL
 DATES
 SHOULD BE
 SHOWN AS
 INDICATED

DATE **MAY 21-22 / 2002**

WORK ORDER NO. / ACCOUNT NO. / TASK NO. ←

TO BE COMPLETED
 BY CITY OF WINNIPEG
 PERSONNEL

LOCATION OF WORK **PORTAGE AND MAIN**

EQUIPMENT SUPPLIER NUMBER

EQUIPMENT
 UNIT NUMBER
 MODEL & TYPE
 LIST ALL
 ATTACHMENTS
 EG. WING & HRS.
 WORKED

EQUIPMENT UNIT NO.	DESCRIPTION	CITY UNIT NO.	USE 24 HOUR CLOCK		OPERATING TIME
			START	FINISH	
123	140G PATROL	1	22:00	07:00	9HRS.
			↑	↑	

START & FINISH
 TIMES MUST BE
 SHOWN USING
 24 HOUR CLOCK

OWNER OF EQUIPMENT **FAMOUS EQUIPMENT RENTALS - 12345**
 (PLEASE PRINT)

COMPANY NAME
 &
 SUPPLIER NUMBER

↓ OPERATORS NAME (PLEASE PRINT) OPERATORS SIGNATURE

IF OPERATOR'S SIGNATURE
 IS ILLEGIBLE, NAME MUST
 BE PRINTED WHERE
 PROVIDED OR BELOW
 SIGNATURE

COMMENTS: (LAY OFF, BREAKDOWN, TRANSFERRED, DISMISSED, ETC.)
 (ATTACHMENTS USED E.G. BLADES, RIPPER, ETC.)

NO LUNCH BREAK

LAI D OFF

WORK
 TICKET
 NUMBER →

134651

FOREMAN'S NAME
 MUST BE LEGIBLE

DISTRIBUTION
 WHITE - 1220 PACIFIC AVENUE
 YELLOW - FOREMAN
 PINK - RETAINED BY OPERATOR

FOREMAN'S SIGNATURE

CHECK ONE

N	E	S	HYDRO	WW
PARKS	CENTRAL SERVICE	P.M.D.		

TO BE COMPLETED BY
 CITY OF WINNIPEG
 PERSONNEL

APPENDIX B

APPENDIX "B"

SCHEMATIC DIAGRAM FOR ARP GAP SYSTEM

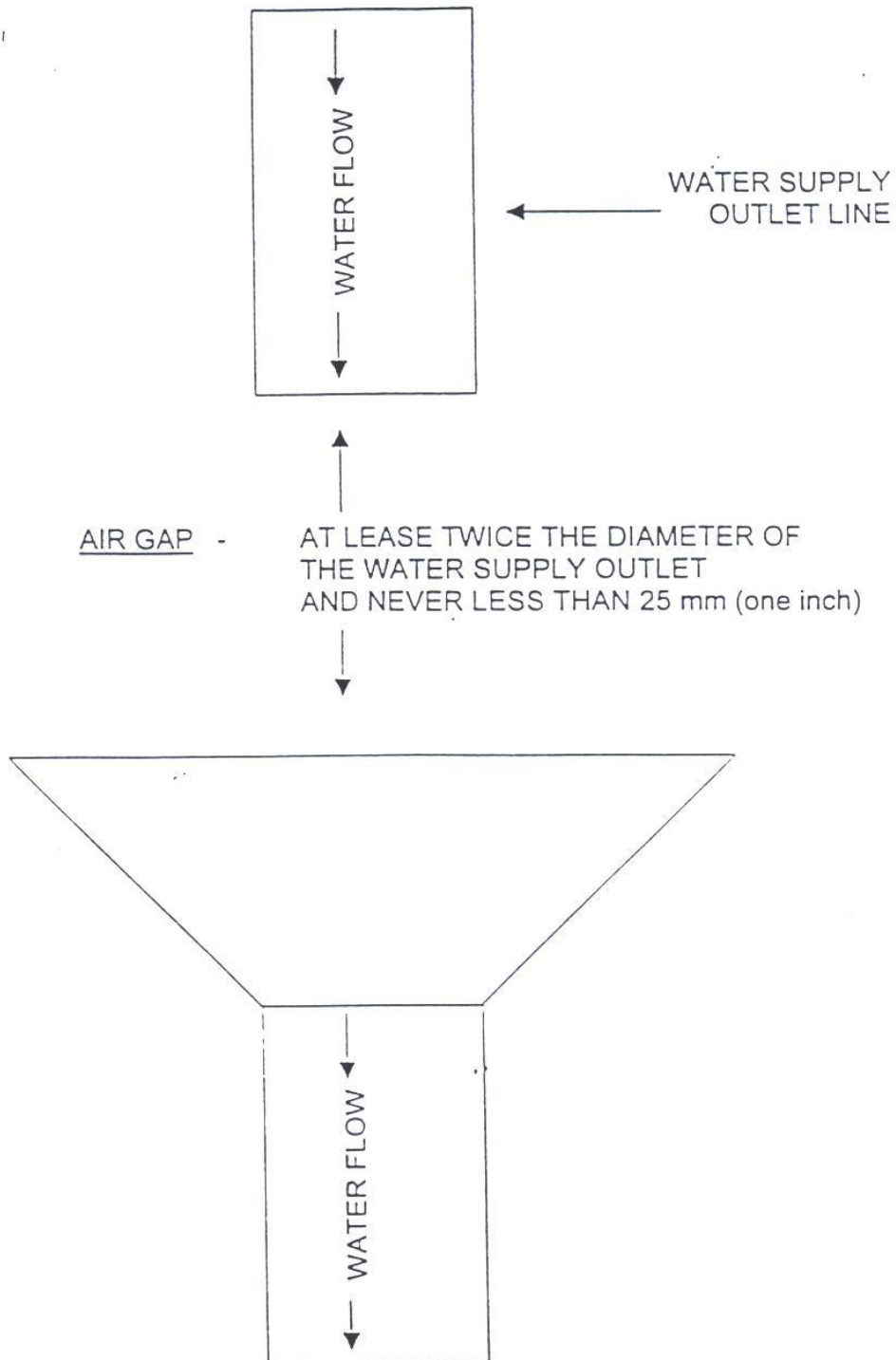

APPENDIX C

Equipment Lighting and Visibility Requirements

Purpose

- To help ensure that adequate warning of work vehicles and equipment is provided to motorists, pedestrians and workers, in and adjacent to construction and maintenance work zones.
- To ensure high visibility lighting is adequate and consistent for all vehicles engaged in work activities for the City of Winnipeg's Public Works Department.

Scope

All vehicles and powered mobile equipment must be equipped with a consistent level of High Visibility Lighting(HVL) to ensure they are visible to motorists, pedestrians and workers. The risk level of equipment/vehicles determines the level of equipment lighting/visibility required. These risk levels are based upon work location and type, travel and working speeds, environmental conditions and applicable regulatory requirements, including but not limited to, the Highway Traffic Act.

This document is designed to assist with the purchase and placement of High Visibility Lighting and establishes the minimum specifications of High Visibility Lighting necessary to operate vehicles/equipment for or with the City of Winnipeg's Public Works Department, with the intent that all applicable Regulations are met or exceeded.

Hazard Categories and explanations for the different classes of equipment are included in the following pages, along with some practical examples. There are many different pieces of equipment that are not listed due to the variety of equipment involved, however, reference to general equipment types/classes are included to assist in ensuring that the equipment engaged is highly visible and meets the minimum requirements described in this document. Four Hazard categories are described in this document, with Level 1 having the highest risk to Level 4 having the lowest risk.

High Visibility Lighting is critical for the visibility of the equipment on the road and in work areas. With recent technological advances, the preferred High Visibility Lighting(HVL) for today's vehicles is becoming LED lighting, however other types will also meet these minimum HVL requirements. These LED lights can be extremely bright with a typically lower current draw on the vehicles electrical system, and can be more dependable and durable.

Be reminded that this document identifies minimum High Visibility Lighting(HVL) requirements, and vehicles/equipment can be equipped with additional High Visibility Lighting if a user wishes, providing the additional level of lighting does not create a hazard to motorists, pedestrians and workers, in and adjacent to construction and maintenance work zones.

With the exception of mobile machinery, valid permits for displaying beacons may be required to be in the vehicle at all times (see Appendices for additional information)..

All City of Winnipeg or contractor supplied equipment and vehicles must meet the minimum High Visibility Lighting requirements identified.

Hazard Categories

Minimum visibility requirements and risk levels are as follows:

Level 1 – Highest Risk

- Equipment that falls under Level 1 includes, but is not limited to, units that operate against the flow of traffic, or which work on the roadway centerline such as:
 - Pavement Marking Truck
 - Water Truck (Figure 1.0)
 - Road Patcher

- Equipment Visibility **Must** include the following:
 - 360° visibility amber beacon/strobe light or equivalent
 - Approved flashing or sequential arrow traffic control device(Figure 1.2)
 - 4-way hazard lights
 - Retro-reflective striping

Figure 1.0



Figure 1.1



Figure 1.0 and 1.1: Tanker equipped with 4 beacons, retro-reflective striping and combined directional lighting/caution signage.

Figure 1.2



Figure 1.3



Figure 1.2 and 1.3: Roadpatcher with directional lighting and informational sign (note front and rear mounted beacon lights)

Hazard Categories (continued)

Level 2

- Equipment that falls under Level 2 includes, but is not limited to, equipment that may work during periods of low visibility such as:
 - Sander
 - Truck Plow (greater than 1 ton)
 - Motor Grader
 - Tow Truck
- Equipment Visibility **Must** include:
 - 360° visibility amber beacon/strobe light or equivalent
 - 4-way hazard lights
 - Two strobe lights for the rear-facing warning lights
 - Retroreflective striping
- Additional lighting/signing is required on units being used for specific tasks, such as pilot vehicles, and shadow/buffer vehicles, etc (Appendix I). All equipment/vehicles used for snowplowing operations will be equipped with two strobe lights for the rear-facing warning lights for increased visibility(Appendix III)

Figure 2.0



NOTE - Blue beacons or strobes can **only** be used during Winter snow removal operations and must be removed or de-energized when the vehicle is not being used in snow removal operations (Figure 2.1 and 2.2)

NOTE - Vehicles typically traveling at a speed less than 40 kilometers per hour **must** be equipped with a slow moving vehicle sign indicating that it is a slow moving vehicle in compliance with the Highway Traffic Act. (See Appendix I)

Figure 2.0: Articulating Loader with roof mounted dual function, amber/blue LED beacon.

Figure 2.1



Figure 2.2



Figure 2.1 and 2.2: Motor Grader with roof mounted dual rotating halogen beacons, slow moving vehicle sign, and caution signage.

Hazard Categories (continued)

Level 3

- Equipment that falls under Level 3 includes, but is not limited to, equipment and passenger vehicles that may be used to enter construction or work zones, examples are:
 - Cars, Vans (excludes those used solely for administrative purposes)
 - Foreman's Trucks (Figure 3.0 and 3.1)
 - Out-front Lawnmowers
 - Skid Steer Loaders
 - Cement Trucks
- Equipment Visibility **Must** include
 - 360° visibility amber beacon light or equivalent
 - 4-way hazard lights



Figure 3.0



Figure 3.1



Figure 3.2



Figure 3.3

Smaller beacons (Figure 3.3) **or equivalent** such as a 360° LED strobe light may be used on the smaller units (i.e. All terrain vehicles, skid steers or out front mowers, etc)

NOTE - Vehicles typically traveling at a speed less than 40 kilometers per hour **must** be equipped with a slow moving vehicle sign (Figure 3.3) indicating that it is a slow moving vehicle in compliance with the Highway Traffic Act. (See Appendix I)

Hazard Categories (continued)

Level 4

- Equipment that falls under Level 4 includes, but is not limited to, units that are not self-propelled (trailers and equipment) and are normally working in a signed or flagged work zone and are attached to other units equipped with beacons, these may include
 - Caboose (work trailer)
 - Compressor
 - Tar Kettle
- Equipment Visibility **Must** include
 - Retro-reflective striping visible on all sides including the trailer tongue
- Towed units that obstruct the towing vehicles tail lights **must** be equipped with tail lights/signal lights as per the Highway Traffic Act. Directional Lighting may be added (Figure 4.2).
- Trailers and attachments not designed to be towed over 40 kilometers per hour **MUST** display a slow moving vehicle sign (Figure 4.3). Especially important when the attachment obscures the towing equipment's slow moving vehicle sign (Appendix I).



Figure 4.0



Figure 4.1



Figure 4.2



Figure 4.3

Lighting/Mounting Locations and Standards

Daytime Running Lights

All vehicles with a Risk Level of 1 to 3 must maintain daytime running lights that comply with the *Motor Vehicle Safety Act* (Canada). (See Appendix I)

Beacons

Mounted in such a way that 360° visibility is achieved. If this is not possible with one beacon, additional beacons must be added to achieve 360° visibility. If this is not possible with a beacon alone then supplemental lighting must be used. This supplemental lighting may include additional beacons and/or strobes until 360° visibility is effectively achieved (See Appendix II)

- Protective cages enclosing the beacons are recommended but not required, provided they do not impede the efficiency of the beacon or alter the structural integrity of the vehicle

Minimum Requirement for Beacons/Strobes

- For all new installations lighting equipment must meet or exceed **SAE J845 Class 2(2007)**
Or
- Previously installed equipment lighting must meet or exceed **SAE J1318 Class 2**

An LED beacon or equivalent is recommended for all new installations(LED recommended due to the dependability and high visibility). They must be able to either rotate, oscillate, pulsate, flash or light intermittently. They must be clearly distinguishable by an approaching motorist at a distance of at least 500 metres (0.5 km) on a bright sunny day.

Reflective Striping (Conspicuity Tape)

Mounted on all sides of the vehicle that faces the flow of traffic and where the vehicle width is 2032mm (80 in.) or wider AND GVWR 4536 kg (10,000 lb.) or more (See Appendix II). All trailers must have retro-reflective tape on all sides.

Requirements of Flashing or Sequential Arrow Traffic Control Devices

The Manual of Temporary Traffic Control (MTTC, 2011 edition) references traffic control devices, see Vehicle Mounted Flashing or Sequential Arrow Traffic Control Device for correct use of Directional lighting. A copy of the MTTC can purchased for a nominal fee at Public Works Customer Service, front desk at 1155 Pacific Avenue Winnipeg, MB. or a copy can be printed from the following link: http://winnipeg.ca/publicworks/InformationAndResources/TrafficControl/manual_of_temp_traffic_control.asp

Special Mobile Machines

A special mobile machine or other vehicle owned or operated by the government or a municipality and being used in snow removal operations shall be equipped with one or more lamps. (Appendix I) Vehicles, up to and including 1 ton trucks, used in snow clearing operations will not be required to be equipped with rear facing strobe lights. These vehicles do require 360° HVL. **Light fleet vehicles (up to 1 tons) engaged in truck plowing in parking lots and Park roadways must not display Blue Beacons.**

Compliance Schedule

All City of Winnipeg vehicles and equipment as well as equipment supplied by organizations under contract with the City of Winnipeg's Public Works Department must meet the Equipment Lighting/Visibility requirements as outlined in this document.

Cement Mixers are new additions and have a compliance date of: October 1, 2012

Excerpts from The Highway Traffic Act

MINIMUM LIGHTING EQUIPMENT REQUIRED

Lighting equipment of vehicles

35(1) Except as otherwise provided in this Act, every vehicle shall, at all times while it is upon a highway, be equipped with lamps and other equipment in good working order as in this section provided, namely:

(n) Every motor vehicle manufactured on or after December 1, 1989, other than a motorcycle or moped, shall carry daytime running lights that comply with the standards prescribed for such lights by the regulations made under the *Motor Vehicle Safety Act* (Canada), and any motor vehicle manufactured before that date, other than a motorcycle or moped, may carry daytime running lights that comply with the standards approved for such lights by the Canadian Standards Association.

Lamps on repair and escort motor vehicles (Figure A1)

35(15) Notwithstanding subsection 38(1), a motor vehicle that is used

(a) by a repairer or a person engaged in the business of towing vehicles, or in connection with the repair or removal of damaged or disabled vehicles; or

(b) to escort oversized vehicles or loads as required by a permit issued therefore under the regulations;

shall be equipped with at least one lamp on its top that is capable of emitting an amber or a yellow light and that has a flashing or oscillating beam clearly visible under normal atmospheric conditions, when illuminated, from all directions for a distance of 150 metres, and, where the motor vehicle is being operated on a highway at a speed in excess of 80 kilometres an hour, clearly visible under normal atmospheric conditions, when illuminated, from all directions for a distance of one kilometre.

Figure A1



Directional Arrows and beacon/strobe for increased visibility, used as a blocking/shadowing vehicle

Excerpts from The Highway Traffic Act (continued)

Lamps on special mobile vehicles (Figure A2)

35(16) A special mobile machine or other vehicle owned or operated by the government or a municipality and being used in snow removal operations shall be equipped with one or more lamps

(a) which, if there is only one, shall show a blue or amber light; and

(b) some of which, if there are two or more, shall show a blue light and some of which shall show an amber light;

and the lamps, in either case, shall have a flashing or oscillating beam and shall be of such size, candle power, and design as may be approved by the traffic board.

Figure A2



Motor Grader with Dual Rotating Strobe lights, where blue is active **only** during Winter snow removal

Lamps on special government or municipal vehicles

35(17) A special mobile machine or other vehicle owned or operated by the government or a municipality and being used in the maintenance or construction of roads or the collection of refuse may be equipped with a lamp or lamps which show an amber light, and the lamp or lamps shall have a flashing or oscillating beam and shall be of such size, candle power, and design as may be approved by the traffic board.

Special permits

37(6) A motor vehicle may be equipped with lighting equipment prohibited under subsection 38(1) if the owner thereof has, upon written application, obtained from the registrar a permit for the purpose specifying the lighting equipment authorized thereby, and stating the conditions, if any, under which it may be used; but the registrar may issue the permit only if, in his absolute discretion, he is satisfied

(a) that the circumstances in which the lighting equipment applied for is required are of such a special and unusual character that it is not in the public interest to refuse to issue the permit; and

(b) that the owner of the vehicle will use the lighting equipment, or cause it to be used, with due regard to the public safety

Excerpts from The Highway Traffic Act (continued)

Prohibited lamps

38(1) Except as otherwise provided in this Act, the regulations or the *Motor Vehicle Safety Act* (Canada), or when authorized by permit under subsection 37(6) or (7), a motor vehicle on a highway shall not be equipped with

(a) more than five lamps of over four candle power (of which not more than four are headlamps) on the front of, or visible from in front of, the vehicle; or

(b) any search light or any lamp other than a stationary lamp; or

(c) any lamp

(i) that casts a light of a colour other than white, or

(ii) that lights intermittently or in flashes; or

(d) any lamp casting a light of over four mean spherical candle power unless it is so constructed, arranged, and adjusted, that no portion of the parallel beams of reflected light, when measured 25 metres or more ahead of the lamp, rises above 1.07 metres from the level surface on which the vehicle stands, as those heights are determined while the vehicle is fully loaded.

Lighting Equipment on Certain Vehicles

Certain utility vehicles

38.1(7) A vehicle owned by Manitoba Hydro, The Manitoba Telephone System or The City of Winnipeg that is equipped or designed for overhead wire construction or repair work may be equipped with one or more amber lamps that rotate, oscillate, pulsate, flash or light intermittently.

NOTE- The Highway Traffic Act prohibits any flashing, strobing or rotating lights on a motor vehicle other than signal lights. As such, beacons are prohibited on all motor vehicles in any color with the exception of specialty vehicles. As such, there is an allowance for the registrar to issue permits for having these kinds of lights. Permits can be obtained from Vehicle Standards and Inspection of MPI.

A permit for beacons must be carried in the vehicle at all times. An permit application is found on page 14 of this document.

City of Winnipeg vehicles are not required to carry a permit for beacons but must comply with the standards outlined in this document.

Excerpts from The Highway Traffic Act (continued)

Warning device on slow vehicles

178(1) Subject to subsection (2), no person shall drive or operate on a highway any vehicle travelling at a speed less than 40 kilometers per hour unless there is displayed on the back thereof a reflectorized warning device of a type approved by the traffic board indicating that it is a slow moving vehicle, or the vehicle is permitted to be equipped with, and is equipped with, a lamp that emits an amber light and that lights intermittently or flashes, and the lamp is in operation and the light there from is visible from the rear.

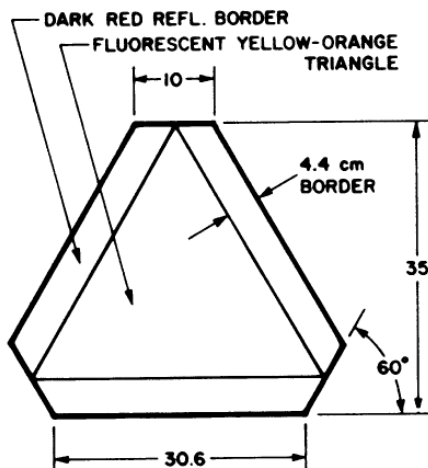

NOTE – Slow Moving Vehicle signs significantly increase rearward equipment visibility and also help to ensure that equipment remains operational during daylight hours in the event that a beacon or other HVL fails. Slow moving vehicles working for/with the City of Winnipeg’s Public Works Department are to be equipped with both HVL and slow moving vehicle signs.

Conspicuity Tape - To be used when the vehicle width is 2032mm (80 in.) or wider AND GVWR 4536 kg (10,000 lb.) or more (**See Figure A and B**)



Motor Vehicle Safety Regulations
Conspicuity Systems - Section S5.7 of TSD 108

(21) Notwithstanding section S5.7 of TSD (Technical Standards Document) 108, the color of retro reflective sheeting applied to a vehicle pursuant to paragraphs S5.7.1.4.1(a) and S5.7.1.4.2 of TSD 108 may be white, yellow, white and yellow or white and red, in accordance with the paragraph S5.7.1.2 of TSD 108 or paragraphs 3.1.3, 3.1.2 and 3.1.1 of **SAE Standard J578**. (**See Table 1 and Figures C to H**)

Table 1

Width 2032mm (80 in.) or wider AND GVWR 4536 kg (10,000 lb.) or more

DESCRIPTION		MANDATORY REQUIREMENTS						Options
Area	Conspicuity Treatment	DOT Coding	Quantity	Color	Location	Height		
9	Rear Upper Body Markings		Exactly 2 pairs of 300mm long strips	White	On the rear upper corners facing rearward	At the top	Reflex reflectors may not be required if they are replaced in their required location with conspicuity treatment. Optional in Canada: Rear lower body and side conspicuity treatment may also be solid white, solid yellow, or white and yellow.	
10	Bumper Bar Marking		Continuous	Red/White	On the rear bumper bar's horizontal element full width - facing rearward	No requirement		
11	Rear Lower Body Marking	DOT-C DOT-C2 DOT-C3 DOT-C4	Continuous	Red/White <i>(see options)</i>	On the rear full width of the vehicle facing rearward	As horizontal as practicable and as close as practicable to the range of 375 to 1525mm from the ground		
12	Side Marking		<i>(see location)</i>	Red/White <i>(see options)</i>	Each side - facing sideward continuous, or evenly spaced over minimum of 50% of length starts and ends as close to the front and rear of the vehicle as practicable	As horizontal as practicable and as close as practicable to the range of 375 to 1525mm from the ground		
<p>NOTE: The edge of red conspicuity tape shall not be closer than 75 mm to the edge of any amber lamp and the edge of white conspicuity tape shall not be closer than 75 mm to the edge of any lamp</p>								

(continued)

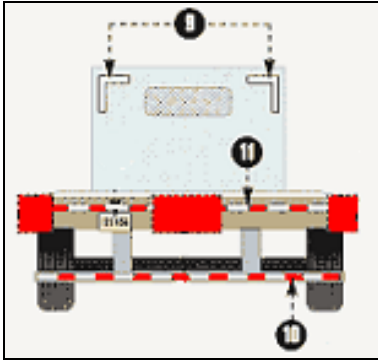

Figure C

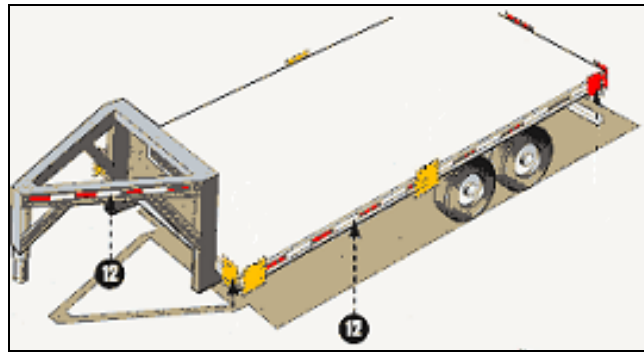

Figure D

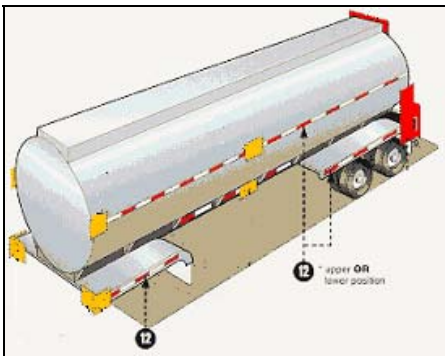

Figure E

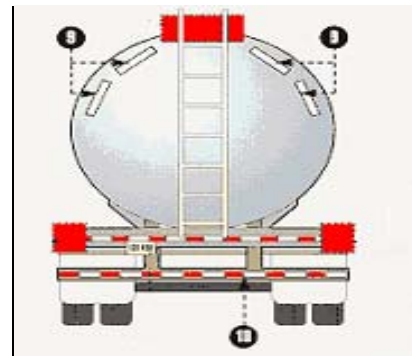

Figure F

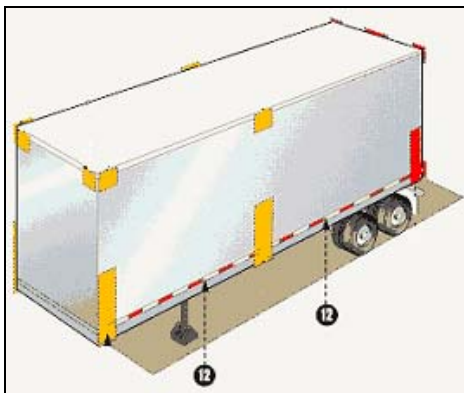

Figure G

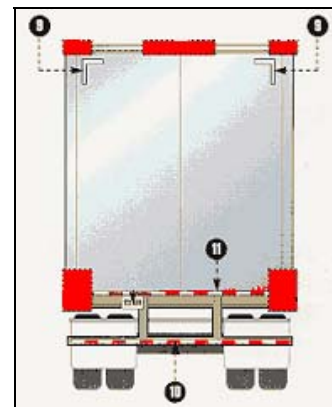

Figure H

Rear Facing Strobes

Strobe lights facing rear

Figure A3-1



Beacon centered on lip of box with protective cage (recommended), providing 360° visibility in combination with strobe lights amber and blue on rear of vehicle (blue - snow removal operations only)

Figure A3-2



Double beacons mounted on lip of box with protective cage (recommended), providing 360° visibility (blue - snow removal operations only) – blue lens and/or beacon to be de-energized for all non snow removal operations

Figure A3



Amber Strobe light at top, with brake/signal/backup light array in side configuration

Figure A3-4

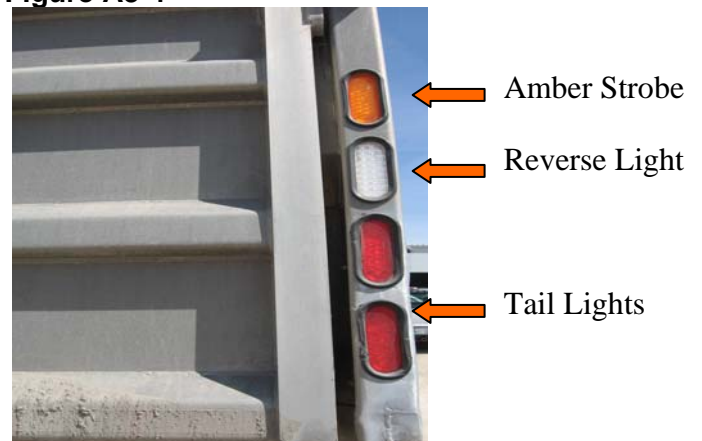

APPLICATION FOR A PERMIT FOR LIGHTING
EQUIPMENT PROHIBITED UNDER SECTION 38(1) OF
THE HIGHWAY TRAFFIC ACT

Name: _____ Address: _____

City/Town: _____ Phone Number: _____ Postal Code: _____

Serial Number: _____ Licence Plate Number: _____

Vehicle Make: _____ Vehicle Model: _____ Year: _____

Application is hereby made for permission to equip the above vehicle with (please check all that apply):

- 1. FLASHING AMBER ()
- 2. FLASHING PURPLE (Funeral vehicles only) ()
- 3. OTHER (Please specify colour and type) () _____

State the reasons the additional lighting equipment is needed: (Please give full details)

If permission is granted the additional lighting equipment will be used with due regard to public safety at all times.

_____/_____
DATE NAME OF APPLICANT (printed) SIGNATURE OF APPLICANT

For Department Use Only:
<u>Conditions of Issue:</u>

Forward to: Manitoba Public Insurance
Vehicle Standards and Inspections
Box 6300
1981 Plessis Road, Bldg "B"
Winnipeg MB R3C 4A4
FAX - (204) 954-5319

APPENDIX D

Figure II – Class 3

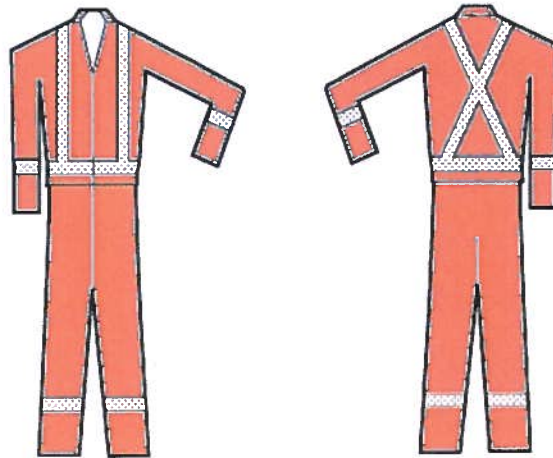
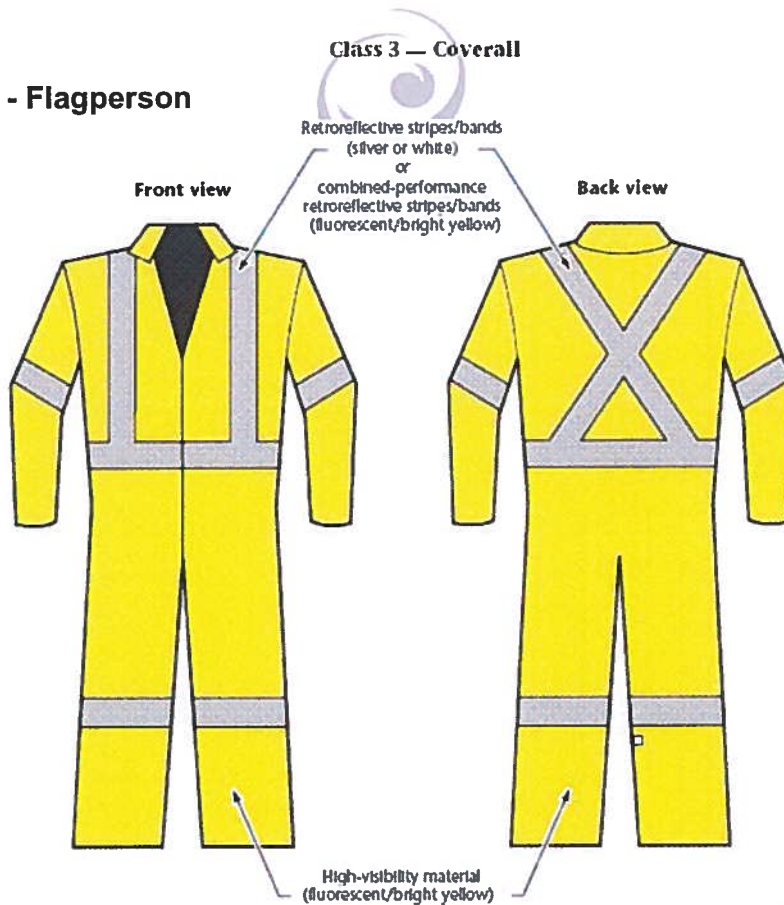

Figure III – Class 3 - Flagperson



Date of Issue

February 14, 2013

Supercedes Issue of:

April 10, 2000

Approved:

Original Signed by

**Brad Sacher, P. Eng.
Director of Public Works**