

NOTES:

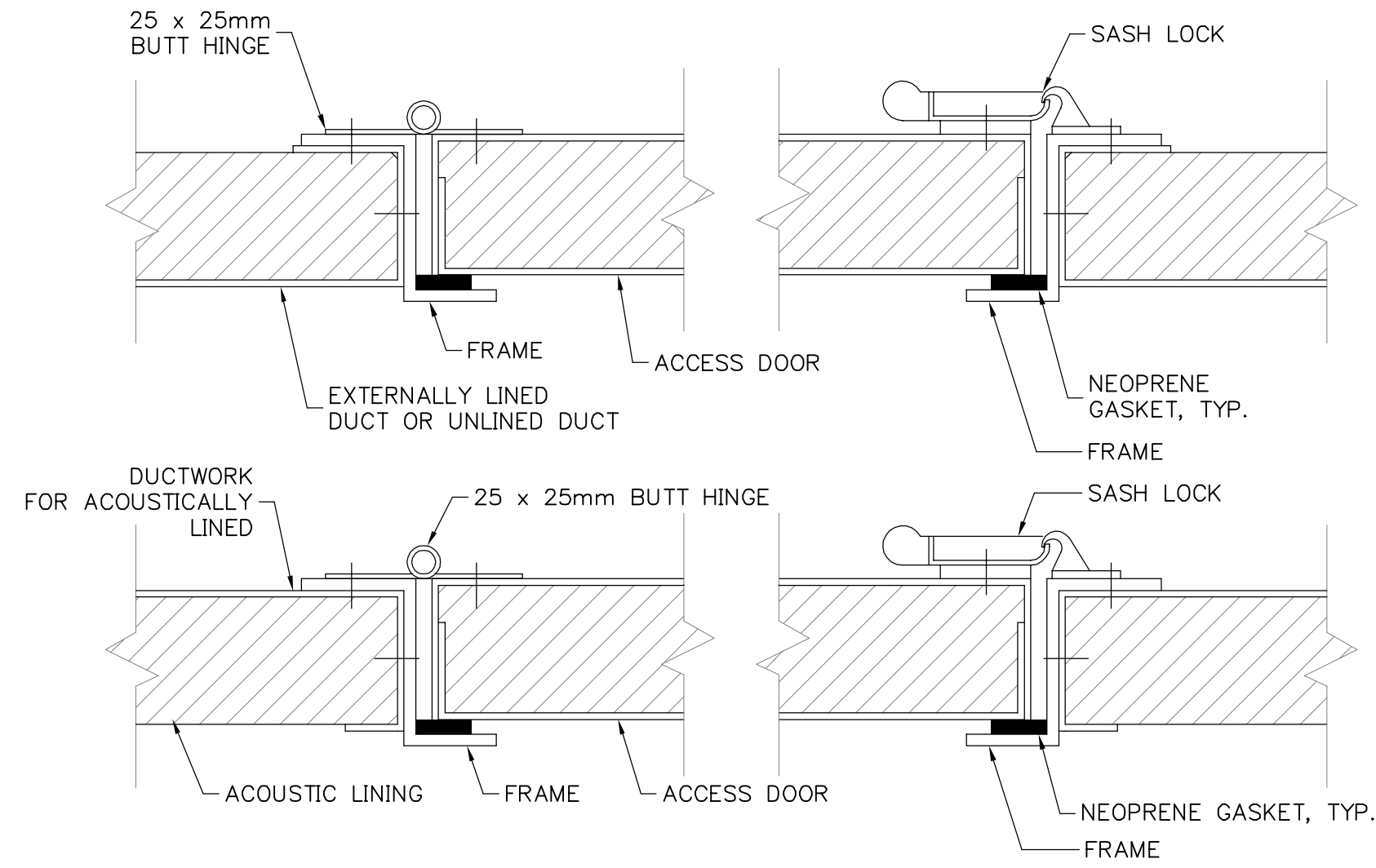

STATIC PRESSURE RATING	DOOR SIZE	HINGE QTY.	LOCK QTY.	METAL GAUGE		
				FRAME	DOOR	BACK
500 Pa & LESS	300 x 300	2	1-S	24	26	26
	400 x 500	2	2-S	22	24	26
	600 x 600	3	2-S	22	22	26
UP TO 750 Pa	300 x 300	2	1-S	22	22	26
	400 x 500	2	1-S,1-T,1-B	20	20	26
	600 x 600	3	2-S,1-T,1-B	20	20	24
1000 Pa to 2500 Pa	300 x 300	2	1-S,1-T,1-B	20	20	26
	400 x 500	3	2-S,1-T,1-B	20	18	24
	600 x 600	3	2-S,2-T,2-B	18	18	24

S: SIDE OPPOSITE HINGE, T: TOP, B: BOTTOM

DETAIL 1
SCALE: NTS
DUCT ACCESS DOOR DETAILS

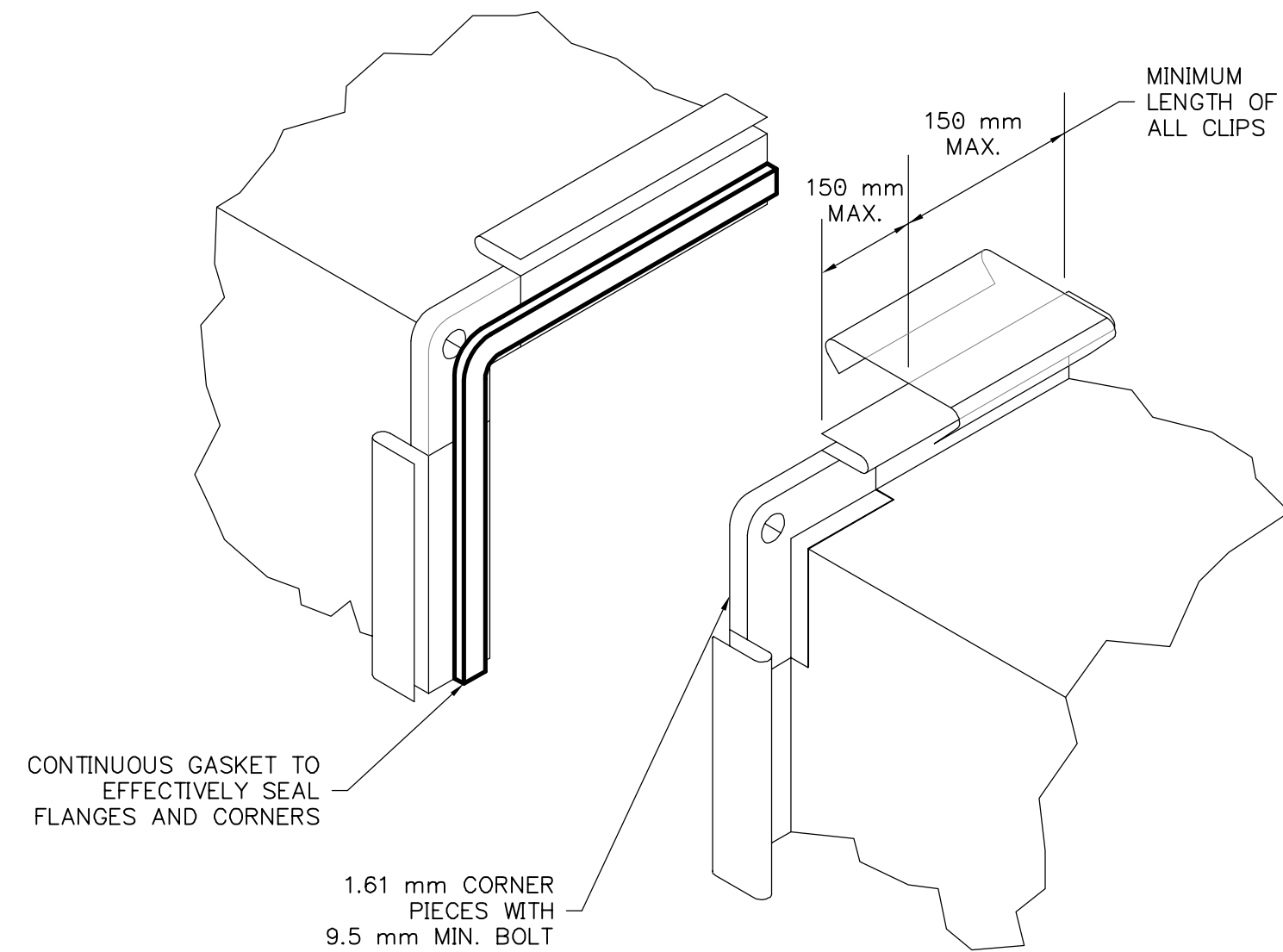

DETAIL 4
SCALE: NTS
SQUARE/RECTANGULAR DUCTWORK CONSTRUCTION DETAIL

NOTES:
SECURELY ATTACH ADDITIONAL METAL CLIPS ON FLANGES AT 380 mm MAXIMUM CENTRES FOR 750 Pa STATIC OR LESS AND AT 300 mm MAXIMUM CENTRES FOR HIGHER PRESSURES. 0.85 mm MINIMUM.
CONTINUOUS CLEATS MAY BE USED.

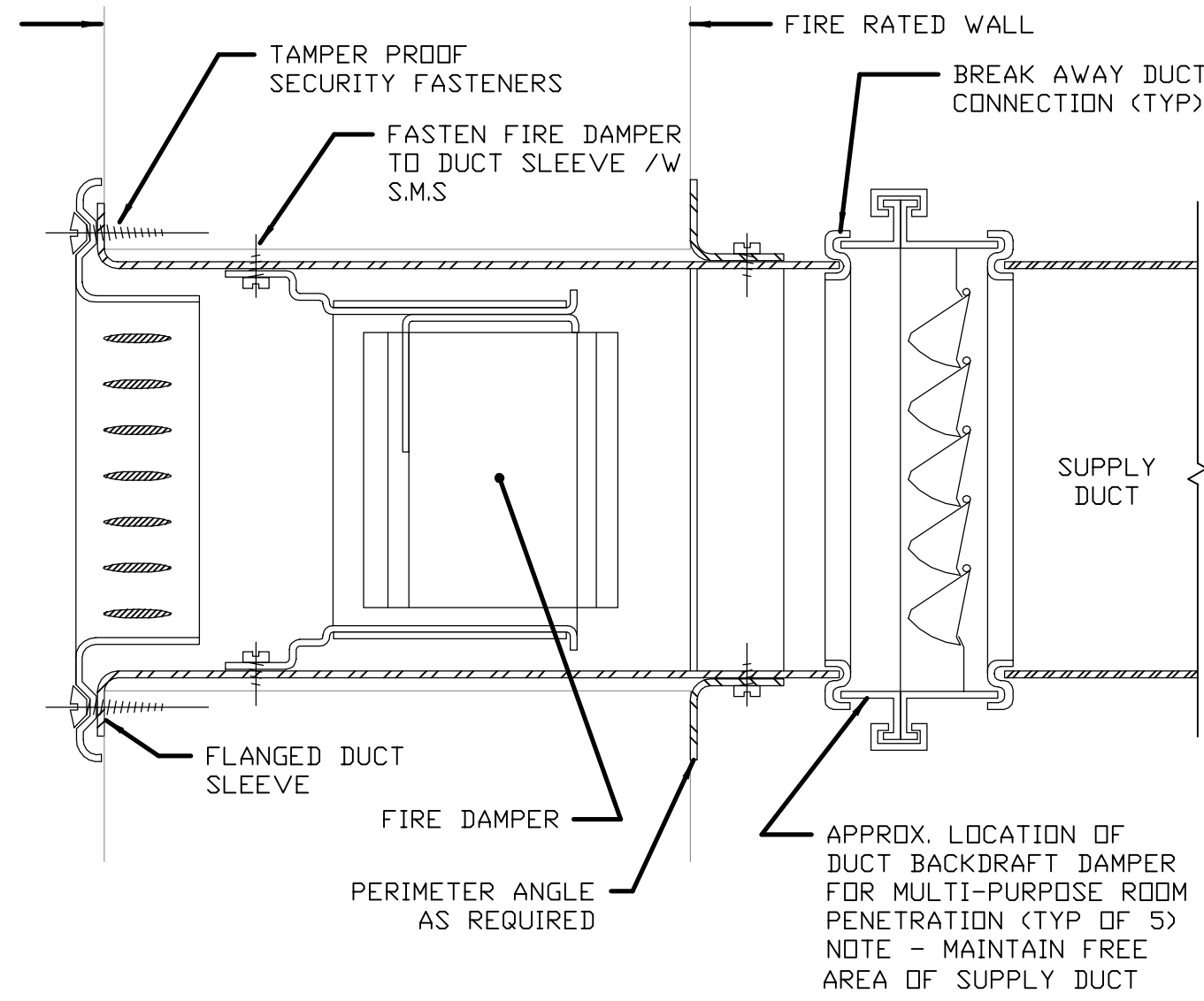
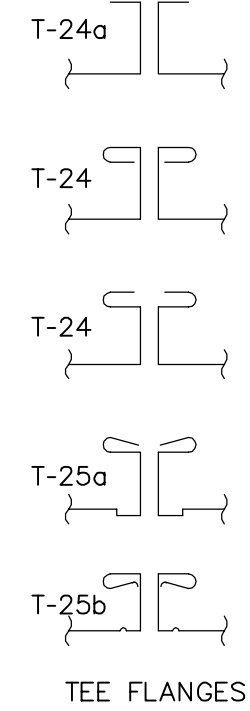

DETAIL 2
SCALE: NTS
DIFFUSER OR GRILLE FIREWALL PENETRATION

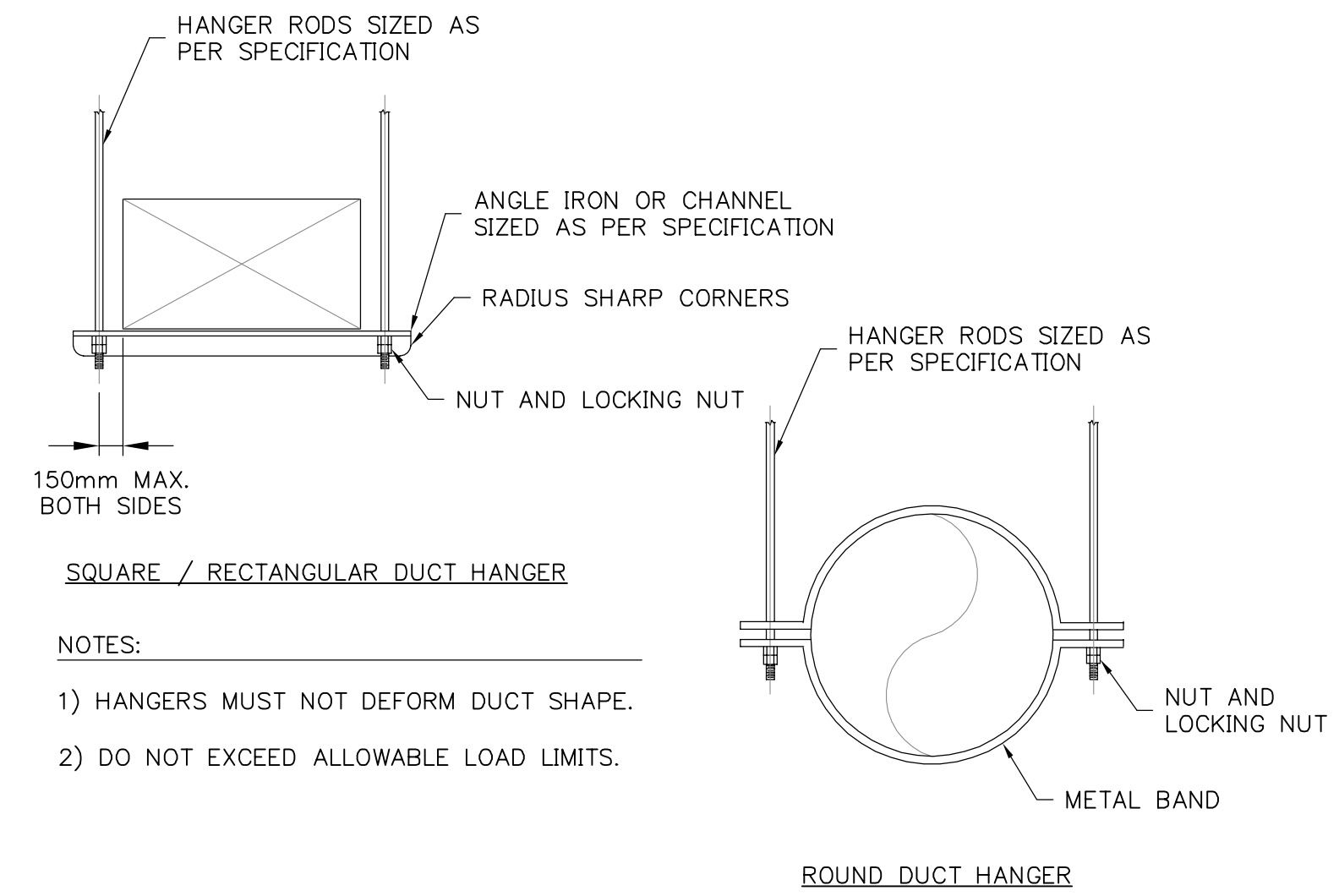

DETAIL 3
SCALE: NTS
DUCTWORK SUPPORT AND HANGER DETAIL

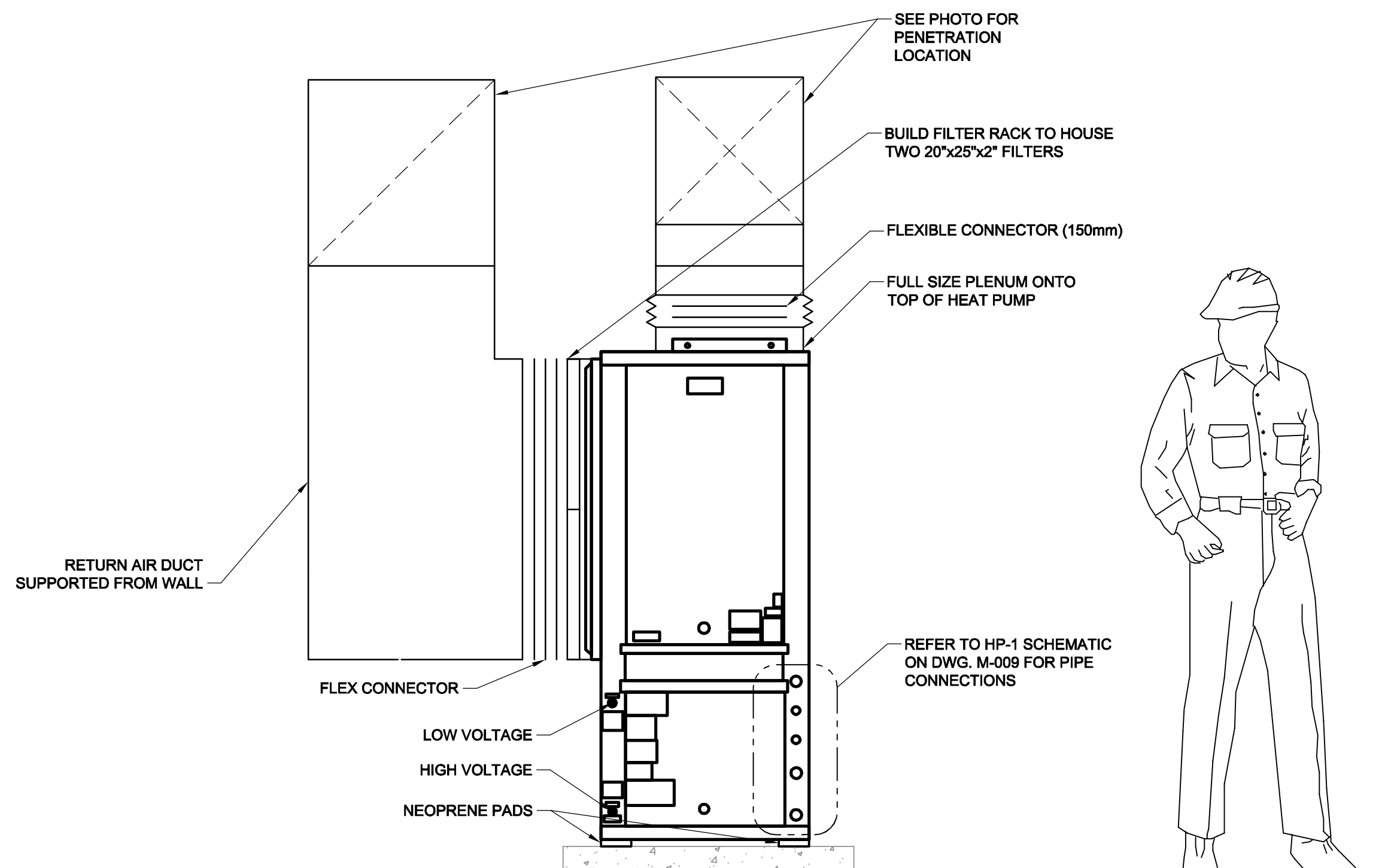

DETAIL 5
SCALE: NTS
HP-1 VENTILATION

AECOM

This drawing has been prepared for the use of AECOM's client and may not be used, reproduced or relied upon by third parties, except as agreed by AECOM and its client, as required by law or for use by governmental reviewing agencies. AECOM accepts no responsibility, and denies any liability whatsoever, to any party that modifies this drawing without AECOM's express written consent. Do not scale this document. All measurements must be obtained from stated dimensions.

No.	REVISION/DESCRIPTION	BY	DATE
0	ISSUED FOR TENDER	GT	2011.11.03

DRAWN	GT	CHECKED	DC	DESIGNED	DC	APPROVED	PVL
DATE	2011.09.02	USER APPROVAL					

THE CITY OF WINNIPEG
PLANNING, PROPERTY AND DEVELOPMENT DEPARTMENT
MUNICIPAL ACCOMMODATIONS DIVISION
3-65 GARRY STREET, R3C 4K4

PROJECT
ADMINISTRATION & COUNCIL BUILDING
REPLACEMENT OF COOLING PLANT - 510 MAIN STREET
BID OPPORTUNITY NO. 673-2011

510 MAIN STREET, WINNIPEG, MANITOBA

SCALE: NTS PROJECT No: 60220937 SHEET No: **M-013**

APEGM
Certificate of Authorization
AECOM Canada Ltd.
No. 4671 Date: _____

DRN	CHK	DES	ENG	IDR
AECOM REVIEW				