

## GENERAL NOTES

1. ALL FIELD DIMENSIONS ARE BE CHECKED AND VERIFIED BY THE CONTRACTOR PRIOR TO STARTING CONSTRUCTION.
2. ALL CONSTRUCTION JOINT LOCATIONS ARE TO BE APPROVED BY THE CONTRACT ADMINISTRATOR.

## STRUCTURAL STEEL

1. FABRICATION AND ERECTION OF STRUCTURAL STEEL TO BE PERFORMED IN ACCORDANCE WITH CSA S16 "STEEL STRUCTURES FOR BUILDINGS".
2. STRUCTURAL SECTIONS SHALL BE IN ACCORDANCE WITH CSA G40.21, GRADE 44W.
3. ALL STRUCTURAL STEEL CONNECTIONS SHALL BE IN ACCORDANCE WITH CSA G40.21, GRADE 44W.
4. PROVIDE GALVANIZING OF MEMBERS TO CSA G164 AS SHOWN ON DRAWINGS.
5. WELDING SHALL BE UNDERTAKEN BY A COMPANY WITH PROVEN CAPABILITY AND SHALL BE A MEMBER IN GOOD STANDING OF THE CANADIAN WELDING BUREAU TO THE REQUIREMENTS OF CSA W47.1.
6. ALL WELDING SHALL CONFORM TO THE REQUIREMENTS OF CSA W59.

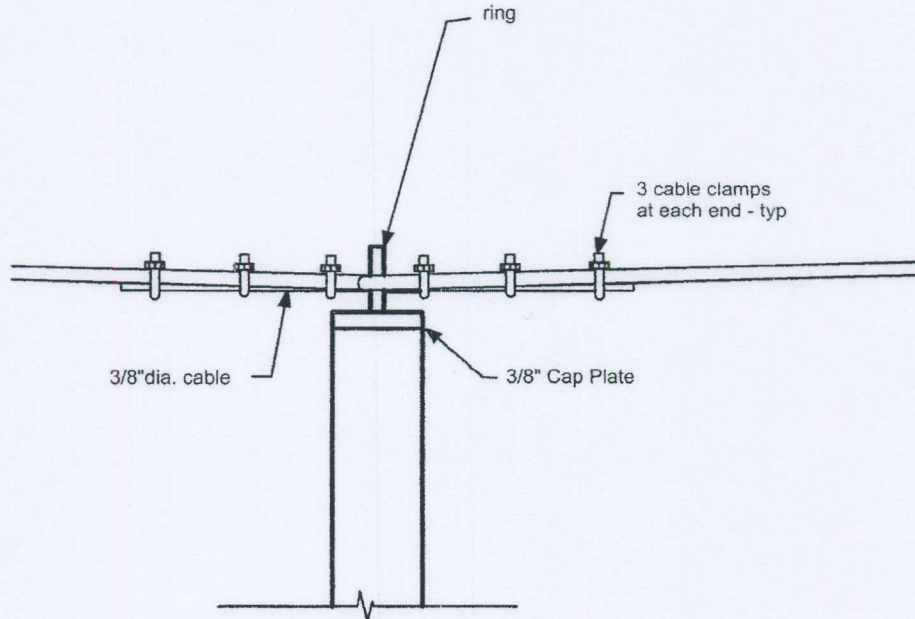

1 SECTION DETAIL  
S-0 SCALE: 3/4" = 1'-0"

**S-0**

New Service Platform  
Oxford Heights Comm. Centre  
359 Dowling Ave East  
Winnipeg MB R2C 3M4

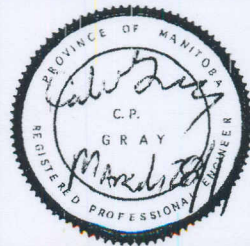

**GC ENGINEERING LTD.**  
675 ELM ST.  
WINNIPEG MB. R3M 3N8  
PH. 793-3948  
EMAIL CALGRAY@LIVE.CA