

A1 SIZE 594mm x 841mm

PL. 01-5/31/2011 3:06:22 PM

FILE NAME: W11400100-T-021_RX.dwg Saved By: dlane

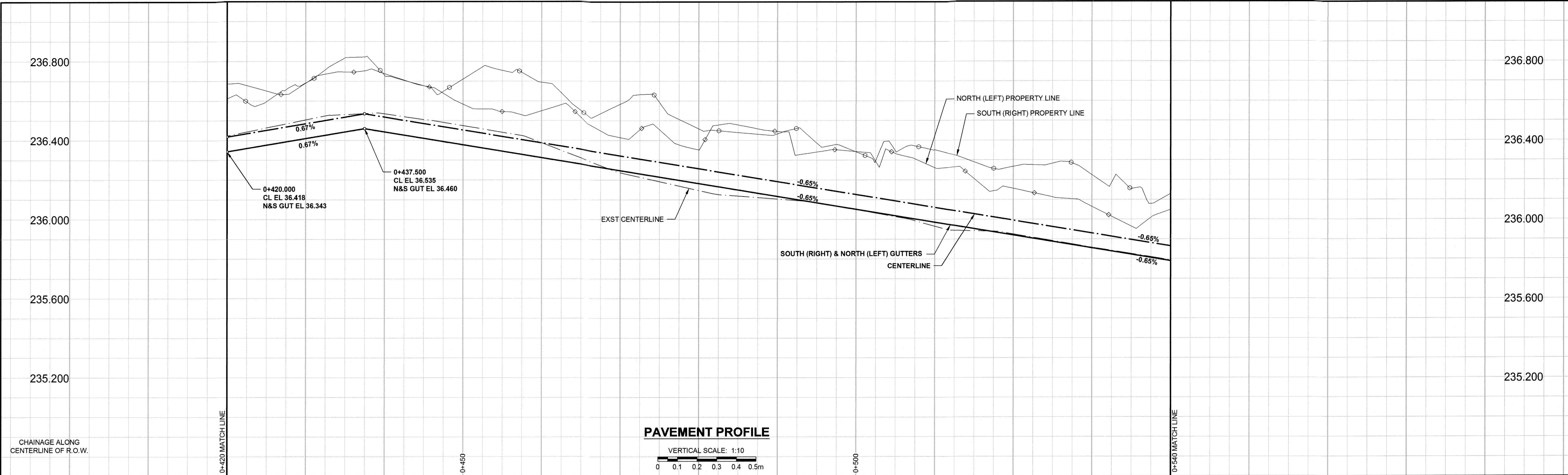

PAVEMENT PROFILE
VERTICAL SCALE: 1:10
0 0.1 0.2 0.3 0.4 0.5m

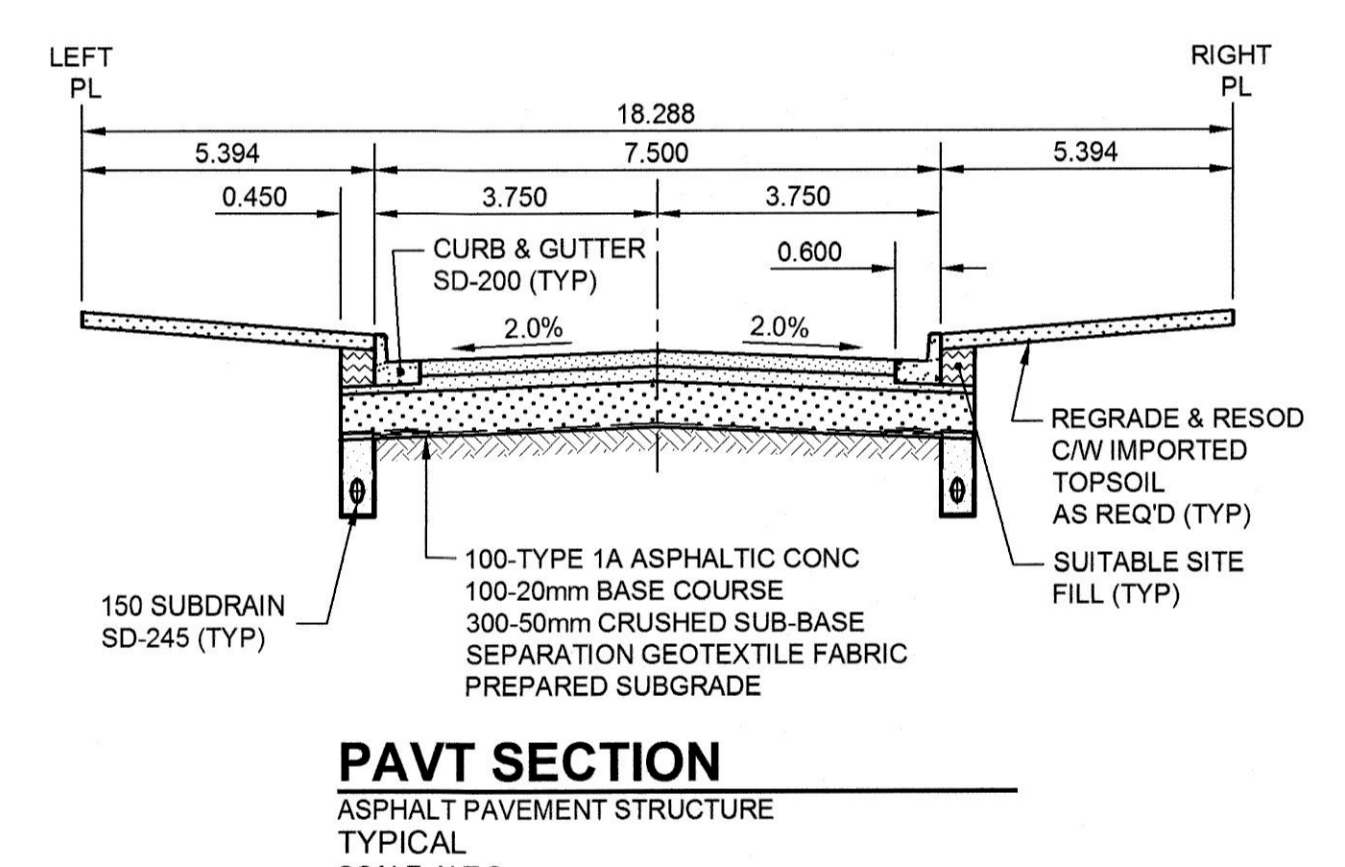
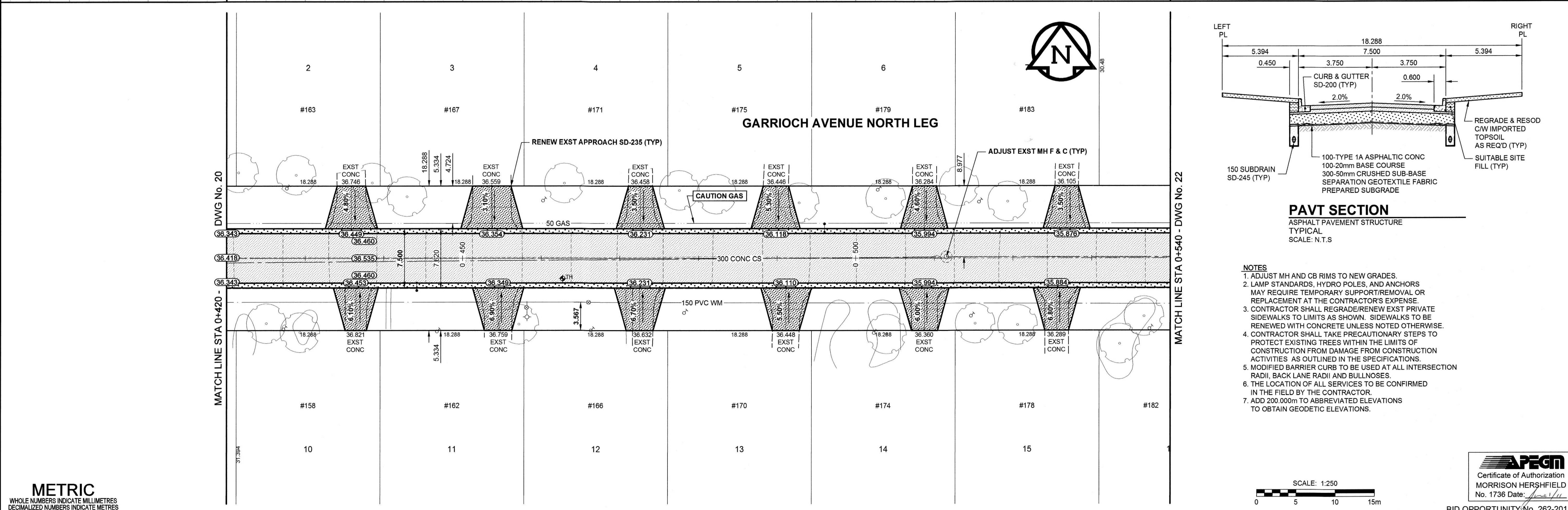

PAVT SECTION
ASPHALT PAVEMENT STRUCTURE
TYPICAL
SCALE: N.T.S.

- NOTES**
1. ADJUST MH AND CB RIMS TO NEW GRADES.
 2. LAMP STANDARDS, HYDRO POLES, AND ANCHORS MAY REQUIRE TEMPORARY SUPPORT/REMOVAL OR REPLACEMENT AT THE CONTRACTOR'S EXPENSE.
 3. CONTRACTOR SHALL REGRADE/RENEW EXST PRIVATE SIDEWALKS TO LIMITS AS SHOWN. SIDEWALKS TO BE RENEWED WITH CONCRETE UNLESS NOTED OTHERWISE.
 4. CONTRACTOR SHALL TAKE PRECAUTIONARY STEPS TO PROTECT EXISTING TREES WITHIN THE LIMITS OF CONSTRUCTION FROM DAMAGE FROM CONSTRUCTION ACTIVITIES AS OUTLINED IN THE SPECIFICATIONS.
 5. MODIFIED BARRIER CURB TO BE USED AT ALL INTERSECTION RADII, BACK LANE RADII AND BULLNOSES.
 6. THE LOCATION OF ALL SERVICES TO BE CONFIRMED IN THE FIELD BY THE CONTRACTOR.
 7. ADD 200.000m TO ABBREVIATED ELEVATIONS TO OBTAIN GEODETIC ELEVATIONS.

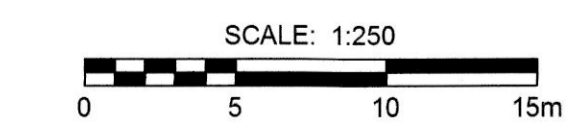

METRIC
WHOLE NUMBERS INDICATE MILLIMETRES
DECIMALIZED NUMBERS INDICATE METRES

<p>LEGEND - PLAN</p> <p>EXISTING LEGEND - PLAN NEW</p>		<p>MANHOLE</p> <p>○ CATCH BASIN / CATCH PIT □ CURB INLET WITH BOX ● TREE △ TEST HOLE — PROPERTY LINE — SURVEY BAR — FENCE — BOC / EDGE OF PAVEMENT — ELEVATION (33.100) — TRAFFIC SIGN</p>		<p>CONCRETE PAVEMENT</p> <p>CONC SIDEWALK / MEDIAN ASPHALT PAVEMENT PAVING STONE GRAVEL RAMP CURB PLANING / REMOVAL</p>		<p>LOCATION APPROVED UNDERGROUND STRUCTURES</p> <p>SUPR. U/G STRUCTURES DATE COMMITTEE</p> <p>NOTE: LOCATION OF UNDERGROUND STRUCTURES AS SHOWN ARE BASED ON THE BEST INFORMATION AVAILABLE. BUT NO GUARANTEE IS GIVEN THAT ALL EXISTING UTILITIES ARE SHOWN OR THAT THE GIVEN LOCATIONS ARE EXACT. CONFIRMATION OF EXISTENCE AND EXACT LOCATION OF ALL SERVICES MUST BE OBTAINED FROM THE INDIVIDUAL UTILITIES BEFORE PROCEEDING WITH CONSTRUCTION.</p>		<p>BM GBM No. 39-003 ELEV 236.241m</p>		<p>MORRISON HERSHFIELD</p> <p>DESIGNED BY RPB CHECKED BY JGK DRAWN BY DID/DML APPROVED BY BWB</p> <p>HOR. SCALE 1:250 VERT. SCALE 1:10</p> <p>RELEASED FOR CONSTRUCTION DATE JUN 11/11</p>		<p>PROFESSIONAL'S SEAL PROVINCE OF MANITOBA REGISTERED PROFESSIONAL ENGINEER R.P. BRUCE</p> <p>CONSULTANT DRAWING No. W11400100-T-021_RX.dwg</p>		<p>THE CITY OF WINNIPEG PUBLIC WORKS DEPARTMENT ENGINEERING DIVISION</p> <p>2011 LOCAL STREET RENEWAL PROGRAM GARRIOCH AVE - RECONSTRUCTION MOUNT ROYAL RD TO MOUNT ROYAL RD STA 0+420 TO STA 0+540</p>		<p>CITY DRAWING NUMBER N/A SHEET 21 OF 29 DRAWING No. 21 REV 0</p>	
---	--	---	--	--	--	--	--	--	--	---	--	--	--	---	--	--	--

BID OPPORTUNITY No. 262-2011