

CW-9-M564-1  
 P:\Projects\2009\09-0754-08\_DocControl\ToBeIssued\DWG\ELECTRICAL\1-0103S-E0025-001-Rev 00.dwg - Tab: 1-0103S-E0025-001 Plotted By: GNeilson 12/16/2010 [Thu 4:42pm]

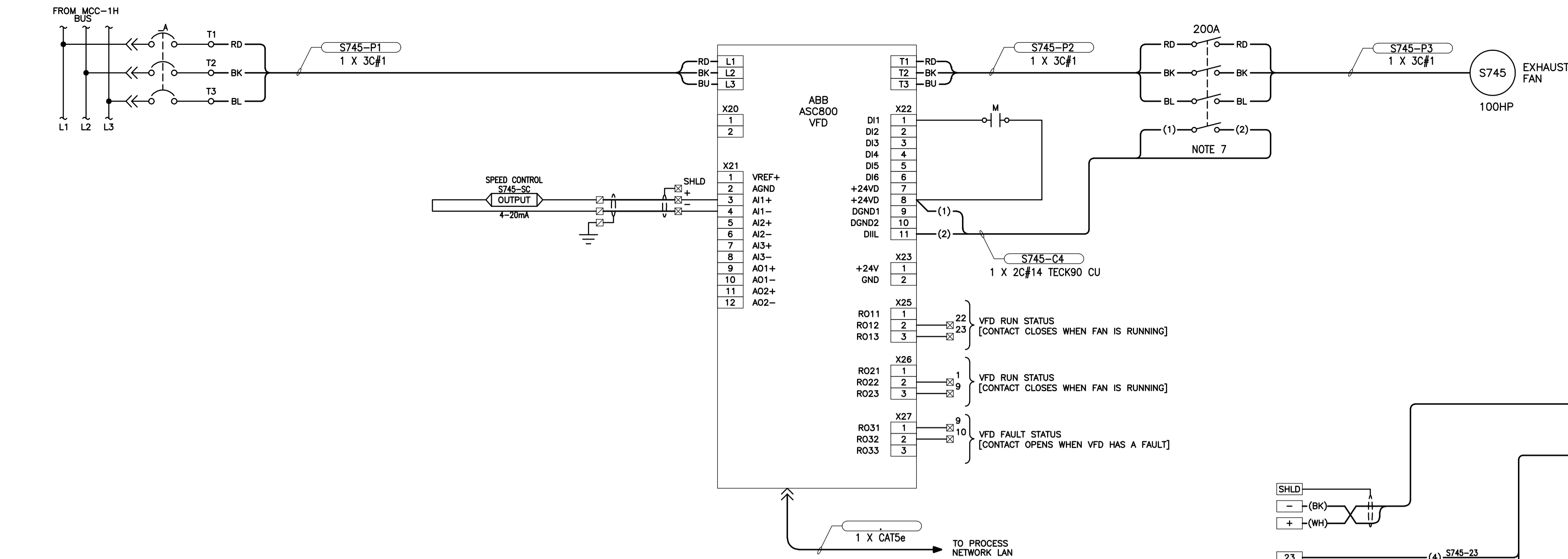

**LEGEND**

- ☐ PLC TERMINALS
- ☒ VFD STARTER TERMINALS
- EF S735 TERMINALS
- FIELD WIRING
- PANEL WIRING
- ( ) CONDUCTOR IDENTIFICATION
- WIRE CONNECTION
- PILOT LIGHT
- ETM ELAPSED TIME METER
- OUTPUT PLC OUTPUT
- INPUT PLC INPUT

**NOTES:**

1. TIMING RELAY STARTS TIMING ON ENERGIZATION AND CONTACT OPENS AFTER TIMEOUT. TIMED OUT RELAY REQUIRES A MANUAL RESET.
2. LIMIT SWITCH CONTACT CLOSING WHEN DAMPER PROVES FULLY OPEN.
3. LIMIT SWITCH CONTACT CLOSING WHEN DAMPER PROVES FULLY CLOSED.
4. LIMIT SWITCH CONTACT OPENS WHEN DAMPER PROVES FULLY CLOSED.
5. LIMIT SWITCH CONTACT OPENS WHEN DAMPER PROVES FULLY OPEN.
6. DAMPER LIMIT SWITCHES MAY REQUIRE MULTIPLYING RELAY(S) IN ORDER TO PROVIDE THE CORRECT NUMBER OF CONTACTS.
7. AUXILIARY CONTACT ON DISCONNECT SWITCH SHALL BREAK BEFORE DISCONNECT OPENS AND MAKE BEFORE DISCONNECT CLOSING.

**CONSTRUCTION NOTES:**

1. REPLACE EXISTING STARTER WRAPPER WITH NEW WITH FEATURES SHOWN ON SCHEMATIC.

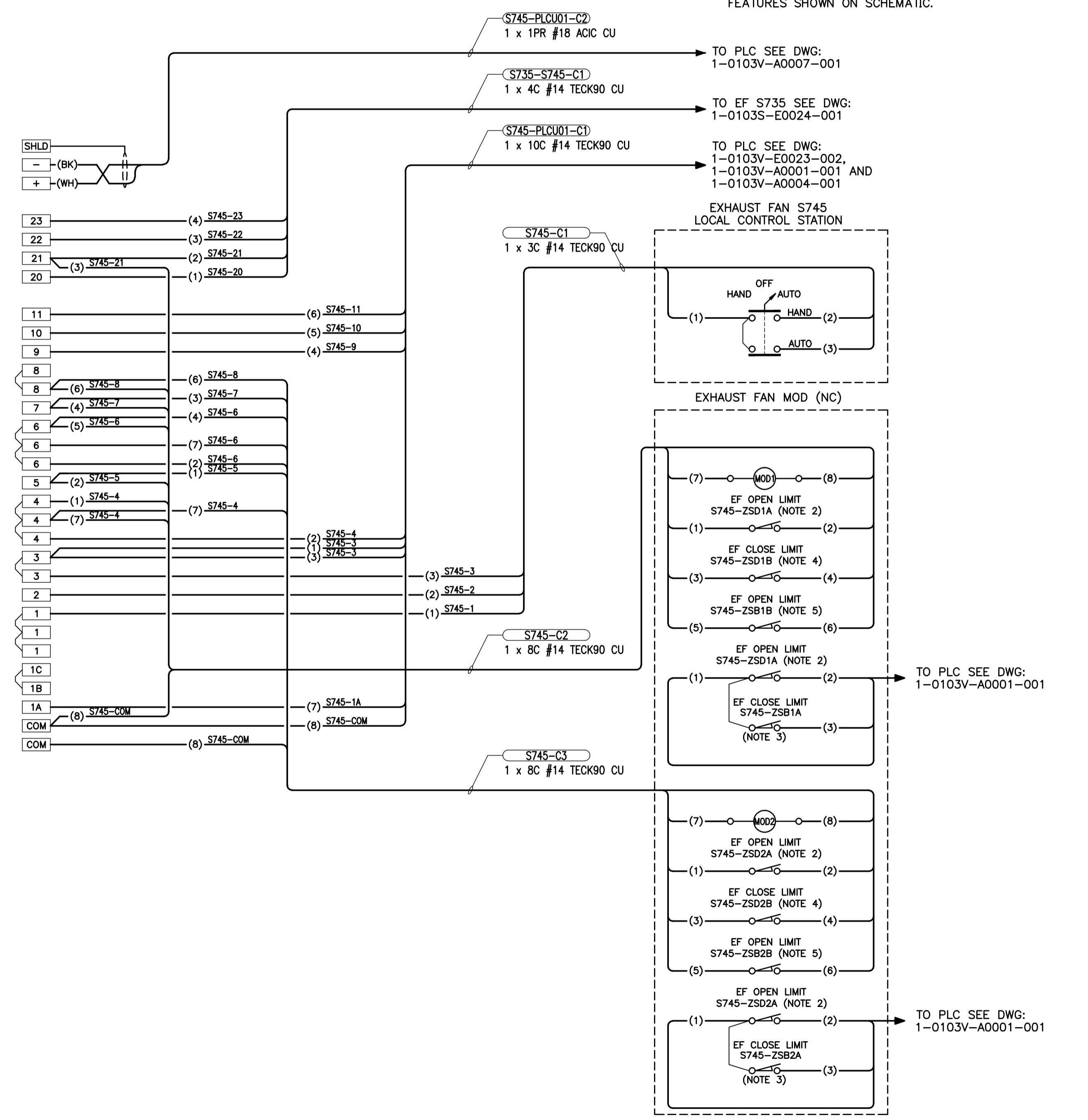
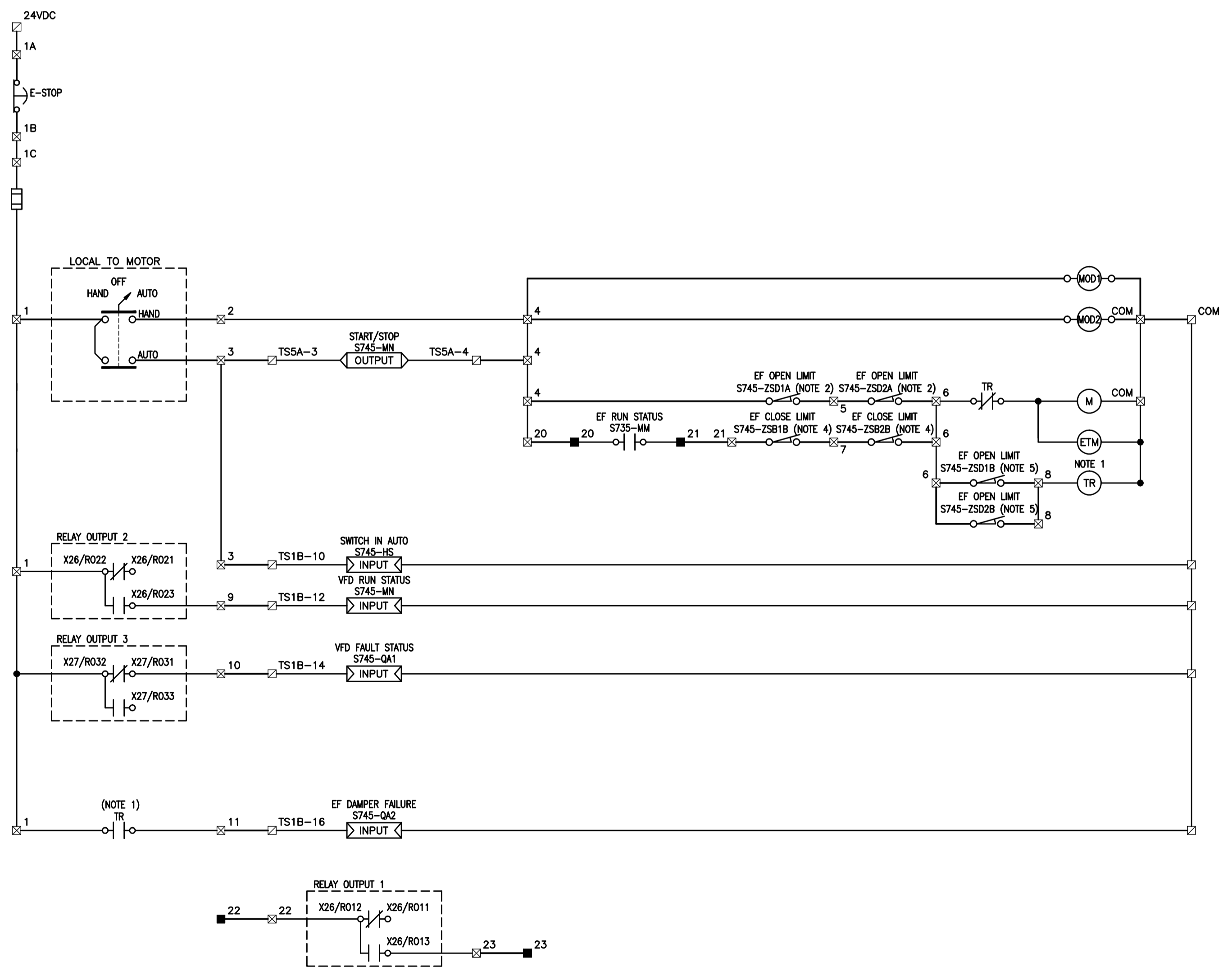

**APEGN**  
 Certificate of Authorization  
 KGS Group  
 No. 245 Date: 2010/12/21

**KGS GROUP**  
 CONSULTING ENGINEERS

NO.	REVISIONS	DATE	BY
00	ISSUED FOR TENDER	2010-12-21	REW

**ALLIANCE**  
 Engineering Services Inc.

DESIGNED BY: REW/DDW	CHECKED BY: REW
DRAWN BY: GCN	APPROVED BY: REW
HDR. SCALE: N.T.S.	RELEASED FOR CONSTRUCTION
VERTICAL: N.T.S.	
DATE: 2009 09 29	DATE:

ENGINEER'S SEAL  
**R.E. WILLMS**  
 Member 3833  
 REGISTERED PROFESSIONAL ENGINEER

**THE CITY OF WINNIPEG**  
 WATER AND WASTE DEPARTMENT

2010 HVAC REPLACEMENT AND ASSOCIATED WORKS  
**WEWPC**  
 AREA S - ODDUR DISPERSION ROOM  
 EF=S745 VFD SCHEMATIC & WIRING DIAGRAM

SHEET 1 OF 1  
 CITY DRAWING NUMBER  
 1-0103S-E0025-001