

ALLOW NECESSARY MATERIAL FOR "RADIUS BENDS" TO MAINTAIN DIMENSIONS  
9" X 18 1/8" 0.125 ALUMINUM PLATE

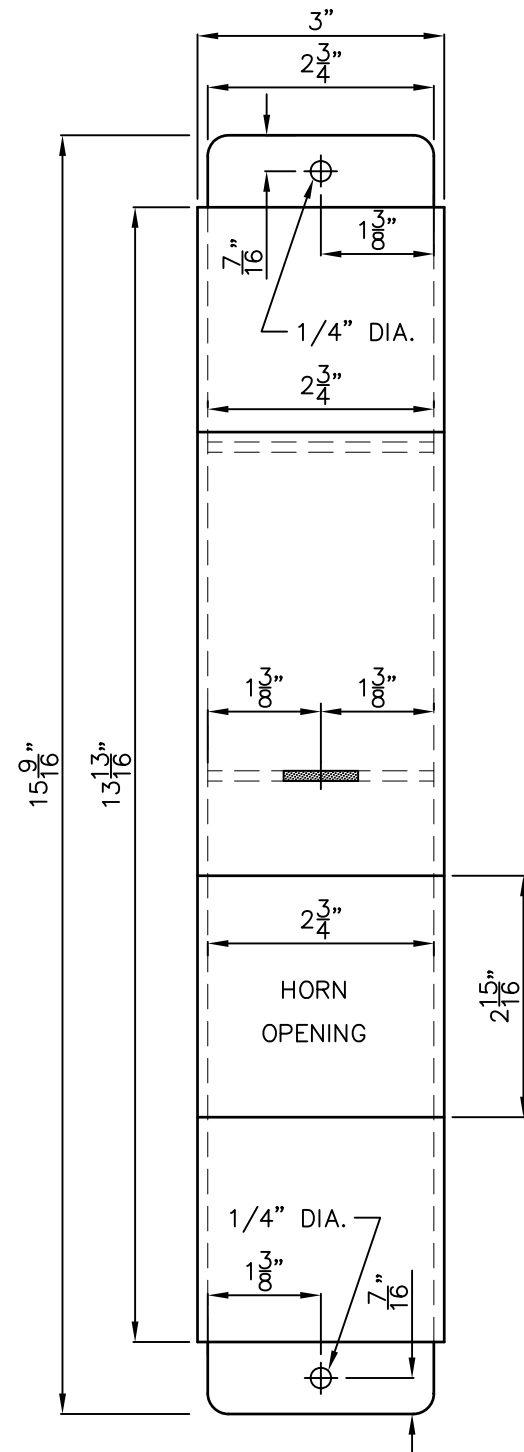

FRONT VIEW

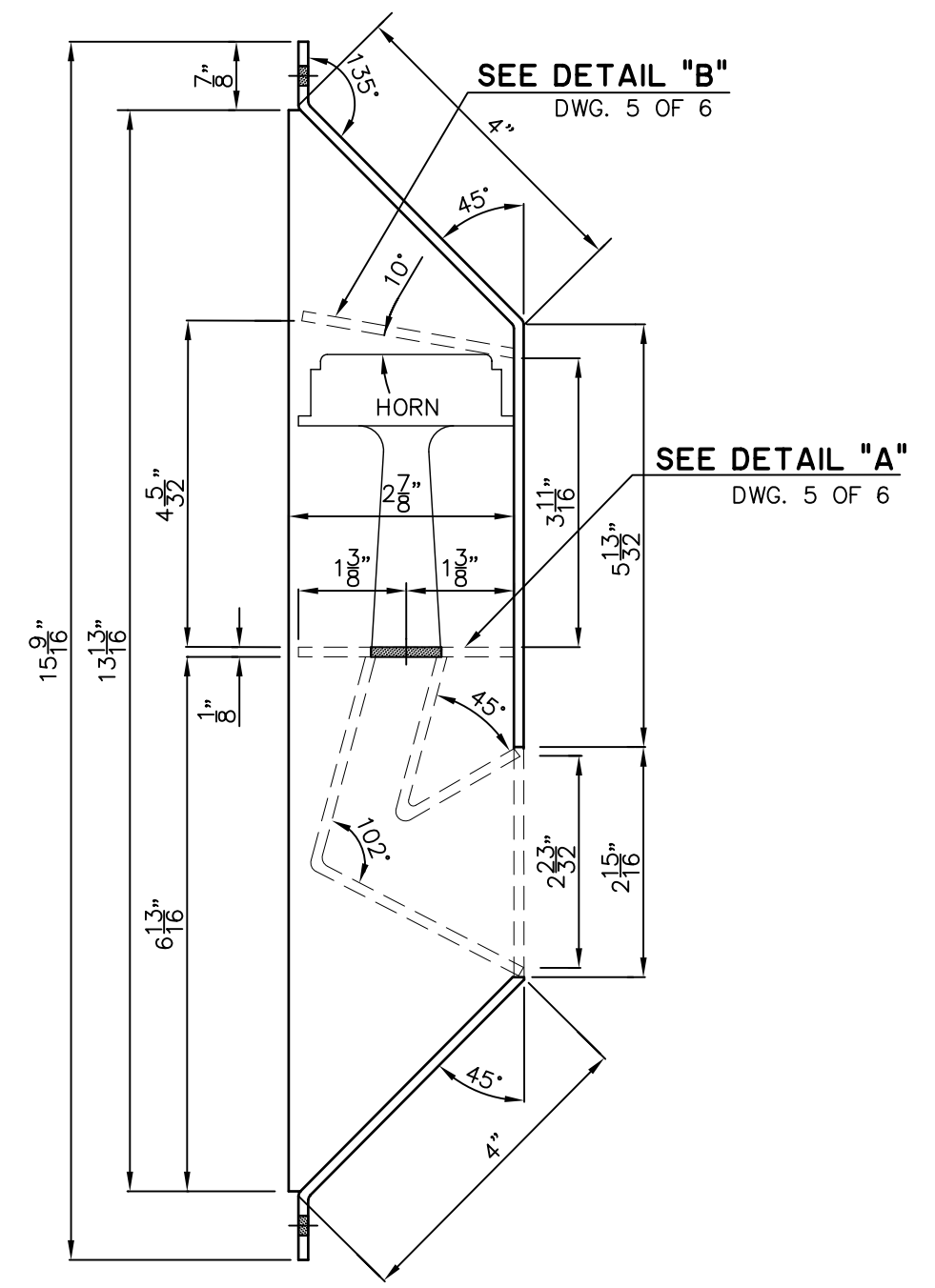

SIDE VIEW

② AUDIBLE BOX  
(0.125" ALUMINUM PLATE)

SEE DETAIL "B"  
DWG. 5 OF 6

SEE DETAIL "A"  
DWG. 5 OF 6

				REFERENCE SPEC. NO.	ENGINEER'S SEAL	<p><b>THE CITY OF WINNIPEG</b> PUBLIC WORKS DEPARTMENT TRANSPORTATION DIVISION</p>	SHEET 2 OF 6
				DESIGNED BY	CHECKED BY		CAD FILE DRAWING NUMBER
				DRAWN BY KR	SCALE N.T.S.		CITY DRAWING NUMBER
				APPROVED BY	KWLR 06/02/14		ST-174
1.	REVISED DIMENSIONS	04,01,27	KR				
NO.	REVISIONS	DATE	BY	DATE			

AUDIBLE BOX

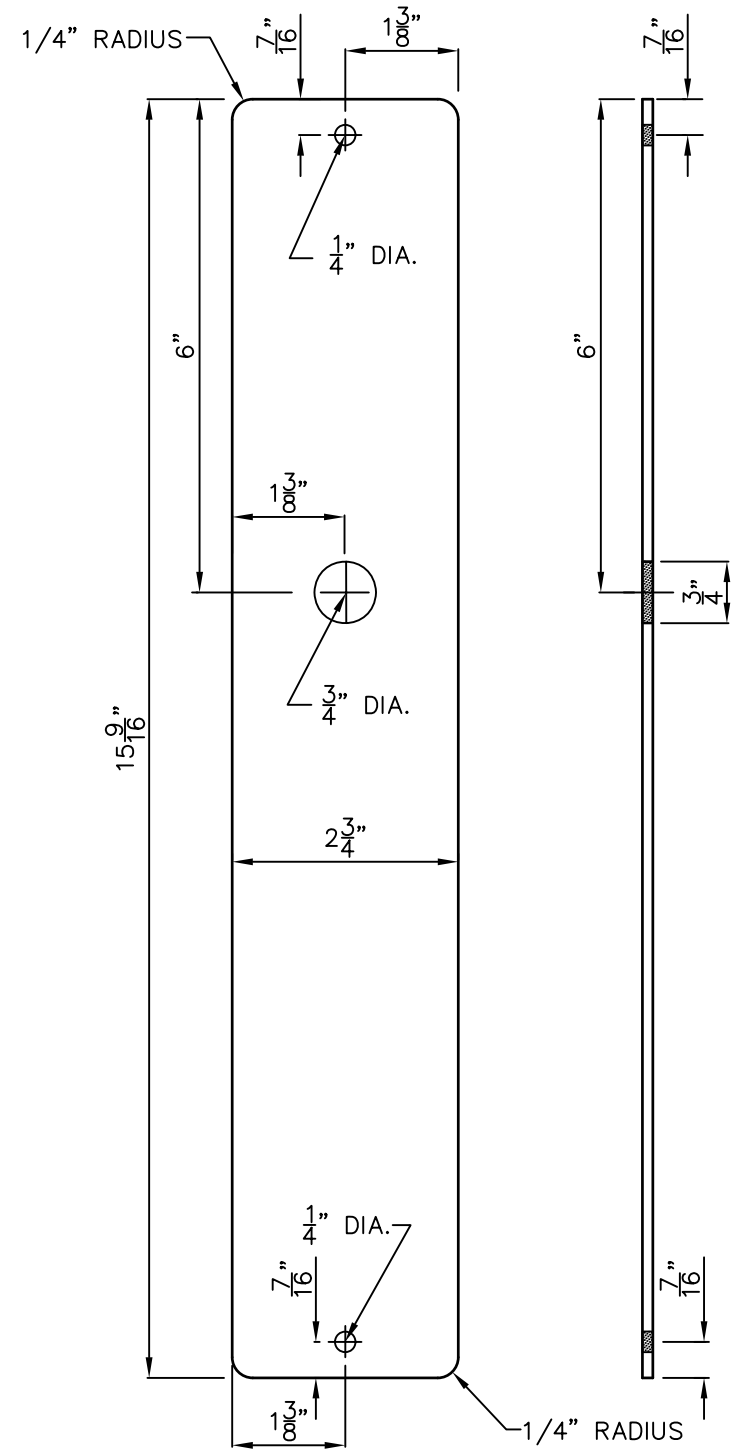

**③ AUDIBLE BOX BACK PLATE FRONT & SIDE VIEW**

(0.125" ALUMINUM PLATE)

				REFERENCE SPEC. NO.	ENGINEER'S SEAL	 <b>THE CITY OF WINNIPEG</b> <b>PUBLIC WORKS DEPARTMENT</b> <b>TRANSPORTATION DIVISION</b>
				DESIGNED BY	CHECKED BY	
				DRAWN BY KR	SCALE N.T.S.	CAD FILE DRAWING NUMBER
				APPROVED BY	KWLR 06/02/14	CITY DRAWING NUMBER
1.	REVISED DIMENSIONS	04,01,27	KR			ST-174
NO.	REVISIONS	DATE	BY			

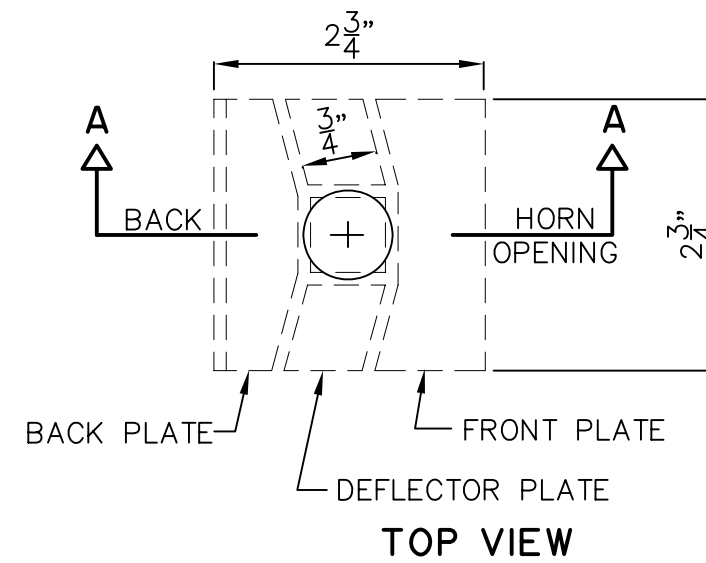
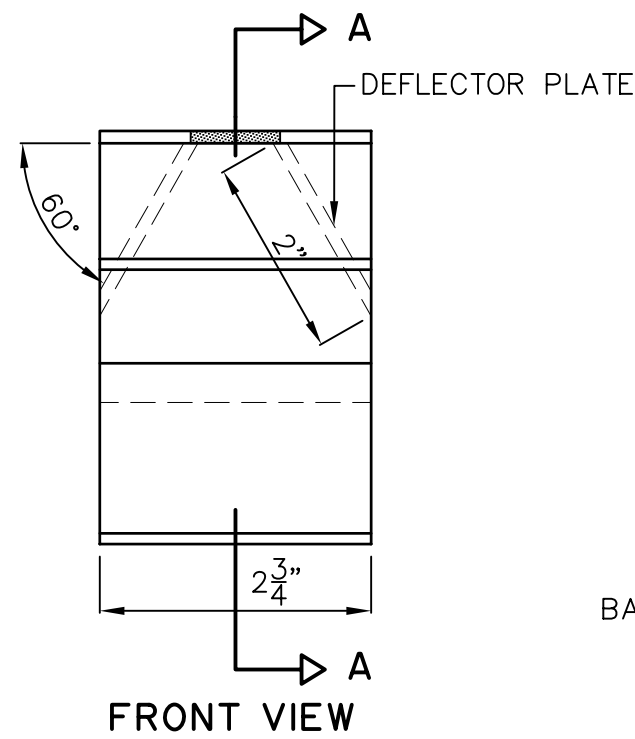
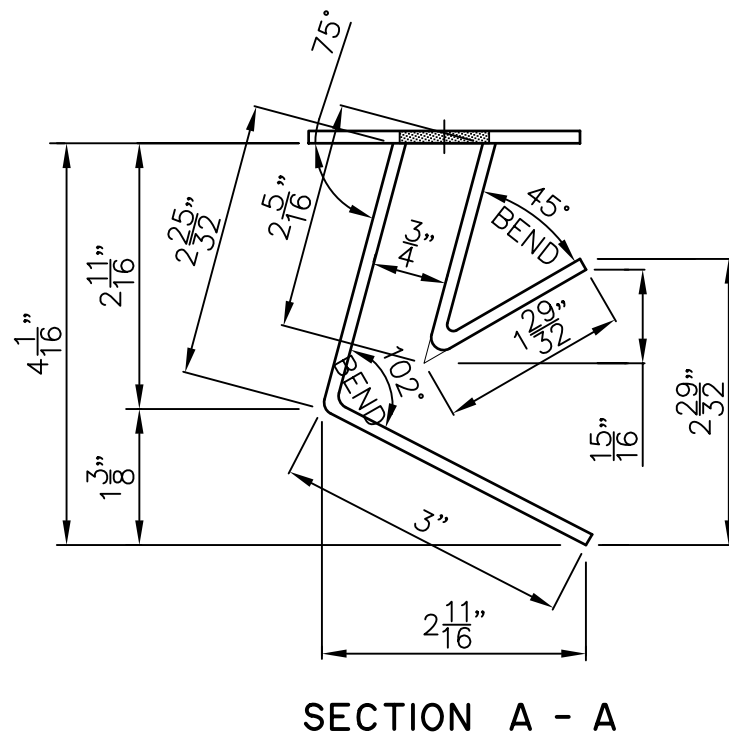
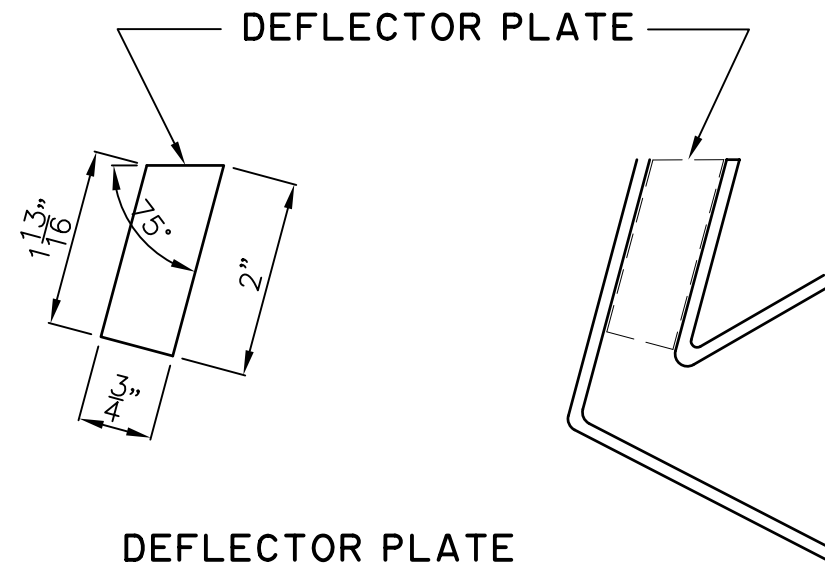
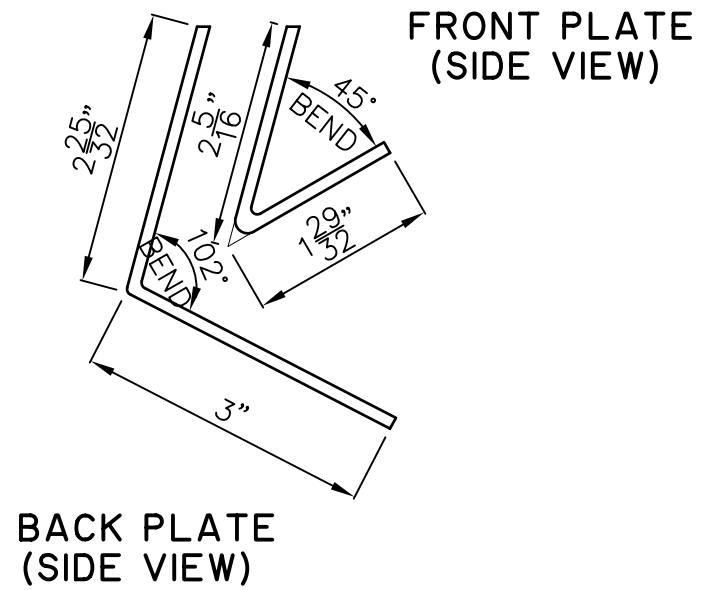

**4 HORN PLATES**

(0.125" ALUMINUM PLATE)

ALLOW NECESSARY MATERIAL FOR "RADIUS BENDS" TO MAINTAIN DIMENSIONS

	REFERENCE SPEC. NO.	ENGINEER'S SEAL	<b>THE CITY OF WINNIPEG</b> PUBLIC WORKS DEPARTMENT TRANSPORTATION DIVISION	
	DESIGNED BY	CHECKED BY		SHEET 4 OF 6
	DRAWN BY KR	SCALE N.T.S.		CAD FILE DRAWING NUMBER
	APPROVED BY	KWLR 06/02/14		CITY DRAWING NUMBER ST-174
1. REVISED DIMENSIONS	04,01,27	KR		
NO.	REVISIONS	DATE	BY	

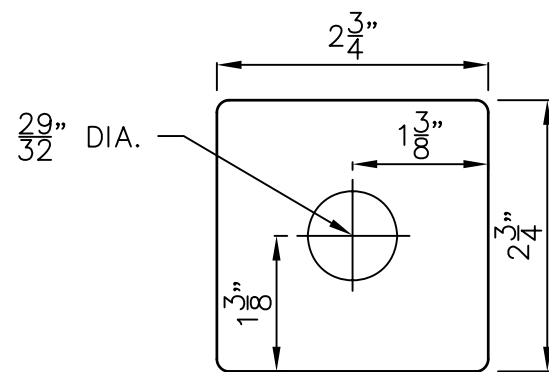

**DETAIL "A"**

(2 3/4" X 2 3/4" 0.125" ALUMINUM PLATE)  
 FILLET CORNERS 1/8" ± RADIUS

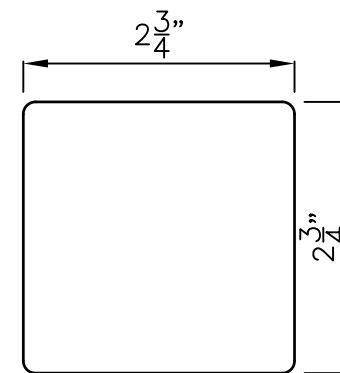

**DETAIL "B"**

(2 3/4" X 2 3/4" 0.125" ALUMINUM PLATE)  
 FILLET CORNERS 1/8" ± RADIUS

**5** DETAILS

(0.125" ALUMINUM PLATE)

				REFERENCE SPEC. NO.		ENGINEER'S SEAL		 <b>THE CITY OF WINNIPEG</b> <b>PUBLIC WORKS DEPARTMENT</b> <b>TRANSPORTATION DIVISION</b>	
				DESIGNED BY	CHECKED BY			SHEET 5 OF 6	
				DRAWN BY KR	SCALE N.T.S.			CAD FILE DRAWING NUMBER	
				APPROVED BY	KWLR 06/02/14			CITY DRAWING NUMBER	
								ST-174	
NO.	REVISIONS	DATE	BY	DATE					

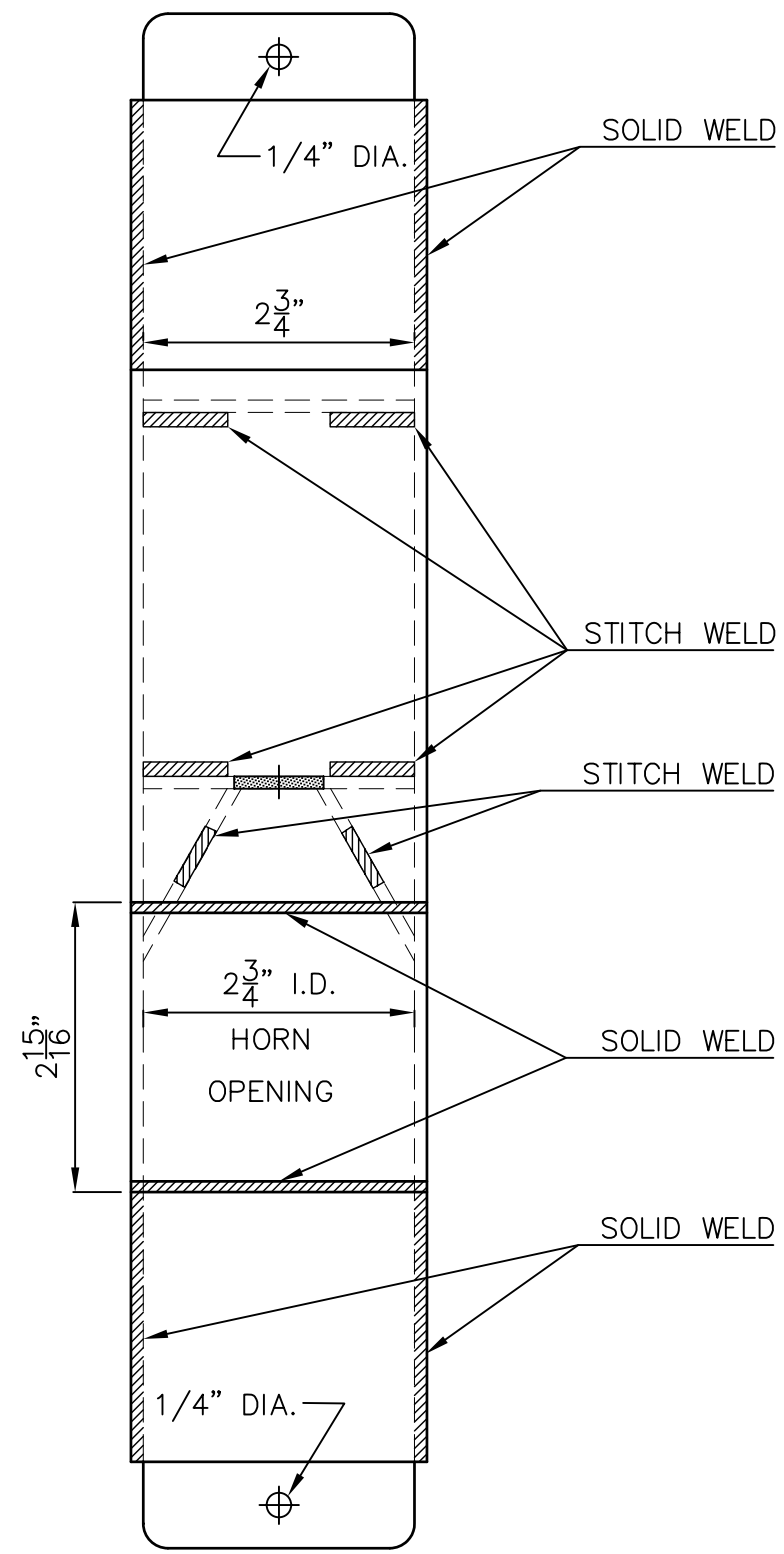

FRONT VIEW AUDIBLE BOX

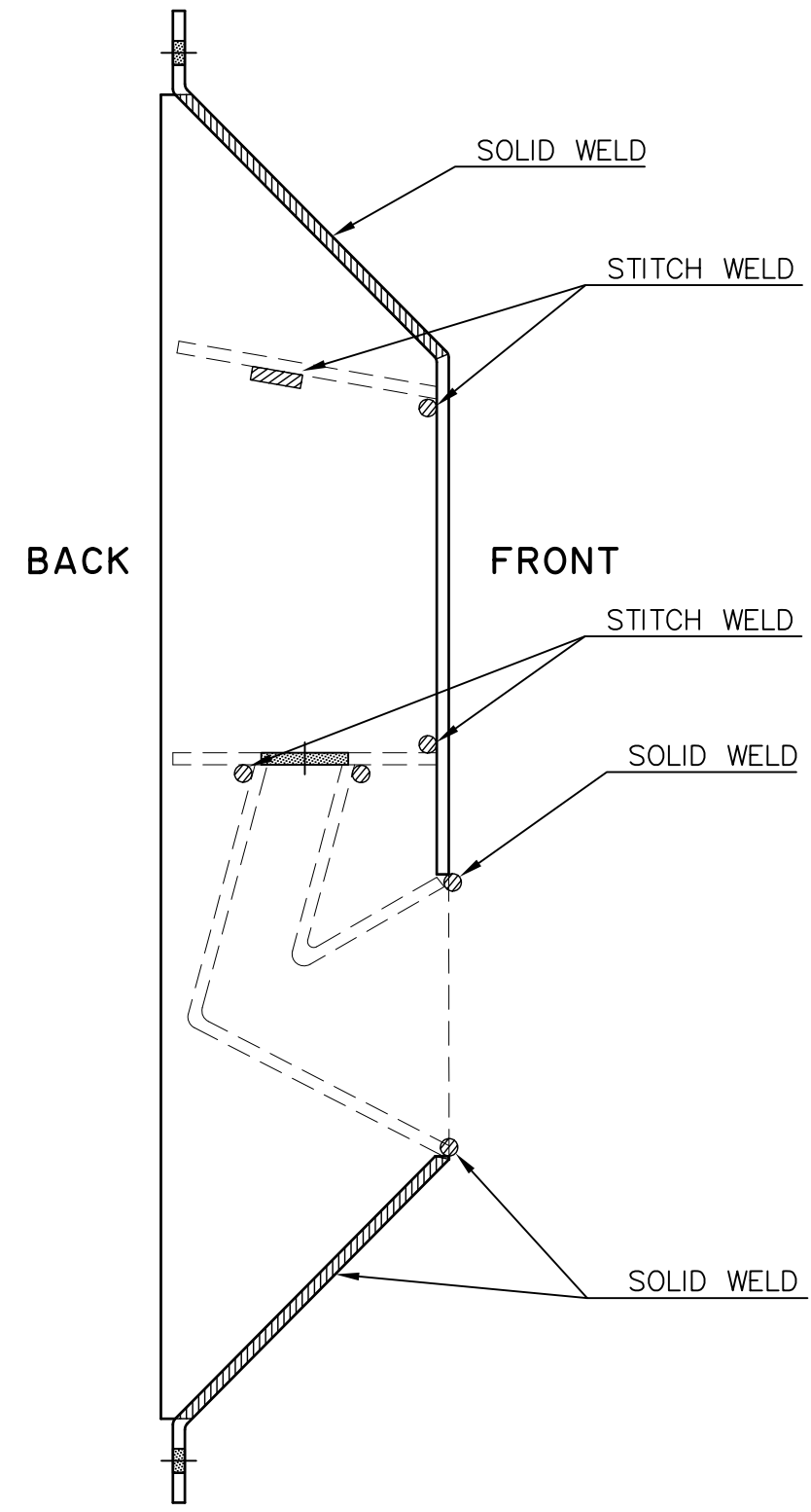

SIDE VIEW AUDIBLE BOX

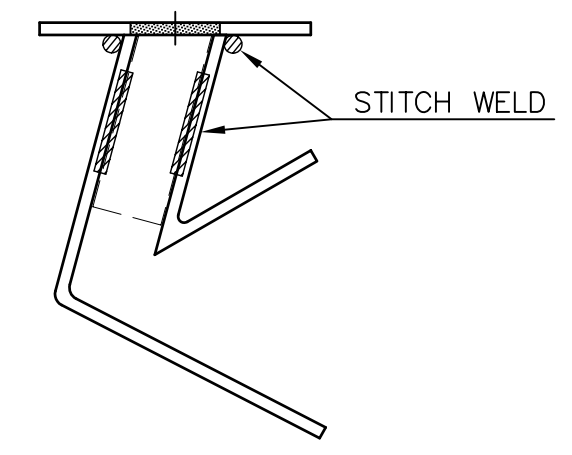

HORN SIDE VIEW

**5** WELDING  
(MIG OR TIG)

<table border="1"> <thead> <tr> <th>NO.</th> <th>REVISIONS</th> <th>DATE</th> <th>BY</th> </tr> </thead> <tbody> <tr><td> </td><td> </td><td> </td><td> </td></tr> <tr><td> </td><td> </td><td> </td><td> </td></tr> <tr><td> </td><td> </td><td> </td><td> </td></tr> </tbody> </table>	NO.	REVISIONS	DATE	BY													REFERENCE SPEC. NO.  DESIGNED BY DRAWN BY <b>KR</b> APPROVED BY KWL R 06/02/14	CHECKED BY SCALE <b>N.T.S.</b> DATE	ENGINEER'S SEAL	 <b>THE CITY OF WINNIPEG</b> PUBLIC WORKS DEPARTMENT TRANSPORTATION DIVISION	SHEET <b>6</b> OF <b>6</b> CAD FILE DRAWING NUMBER CITY DRAWING NUMBER <b>ST-174</b>
	NO.	REVISIONS	DATE	BY																	
<b>WELDING</b>																					
NO.                      REVISIONS                      DATE                      BY                      DATE																					
(MIG OR TIG)																					