

General Notes

1. Contractor shall review these plans thoroughly, make a detailed site visit, and shall immediately bring any inconsistency, site layout problem, or any other request for clarification to the Contract Administrator for resolution prior to the delivery of any bid. Failure to do so shall cause the Contractor to be ineligible for extras relating to such matters.
2. Contract Administrator will mark out exact location of catchbasin prior to installation.
3. Contractor to obtain and pay for all permits
4. Contractor to obtain and confirm exact locations and elevations of all utilities prior to start of construction
5. Backfill under pavement to be class one
6. Backfill in landscaped areas to be class five

Materials

1. SD-025 Standard Pre-Cast Concrete Basin in Boulevard
900 mm x 1.83 m c/w applicable risers/reducers and rings
2. LDS PIPE SDR-35 OR EQUAL

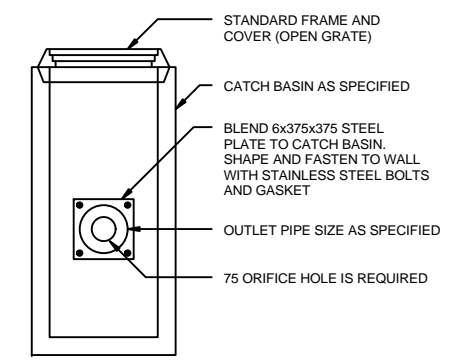

ORFICE DETAIL
N.T.S.

| LEGEND | |
|---------------------------------|----------------------------------|
| EXISTING | Proposed |
| Elevations | 32.00 Catch Basin |
| Top of Curb Elevations | (32.00) Proposed 200 P.V.C. Pipe |
| Contour Lines | ~ Add 200.00 for all elevations |
| Curb and Gutter Inlet | □ G.B.M. 52-019 - 231.196 |
| Existing Catch Basin | ○ |
| Catchment Area - 5200 sq metres | - - - |

CONTRACTOR TO CONFIRM ALL DIMENSIONS AND REPORT ANY DISCREPANCIES TO CONTRACT ADMINISTRATOR PRIOR TO CONSTRUCTION. LOCATION OF UNDERGROUND STRUCTURES AS SHOWN ARE BASED ON THE BEST INFORMATION AVAILABLE BUT NO GUARANTEE IS GIVEN THAT ALL EXISTING UTILITIES ARE SHOWN OR THAT THE GIVEN LOCATIONS ARE EXACT. CONFIRMATION OF EXISTENCE AND EXACT LOCATION OF ALL SERVICES MUST BE OBTAINED FROM THE INDIVIDUAL UTILITIES BEFORE PROCEEDING WITH CONSTRUCTION.



THE CITY OF WINNIPEG
Planning, Property and Development Department
Planning and Land Use Division
Unit 15 - 30 Fort Street, Winnipeg, MB, (R3C 4X5)

| | | | |
|--------------|-------------|-------------|--|
| DESIGNED BY | j.f. | CHECKED BY | |
| DRAWN BY | j.f. | APPROVED BY | |
| HORIZ. SCALE | 1:500 | | |
| VERT. SCALE | | | |
| DATE | Aug 1, 2009 | | |

| | |
|--|------|
| MANAGER, PARK AND OPEN SPACES | DATE |
| MANAGER, PLANNING AND LAND USE DIVISION | DATE |

| | |
|---|---------------------|
| DRAWING TITLE | DRAWING NO. |
| Enderton Park Land Drainage Sewer Installation | E-12-C |
| SITE ADDRESS | BID OPPORTUNITY NO. |
| Palk Ave. & Ruskin Row | |