

1 TOP GIRT DETAIL  
SCALE: 1 1/2"=1'-0"

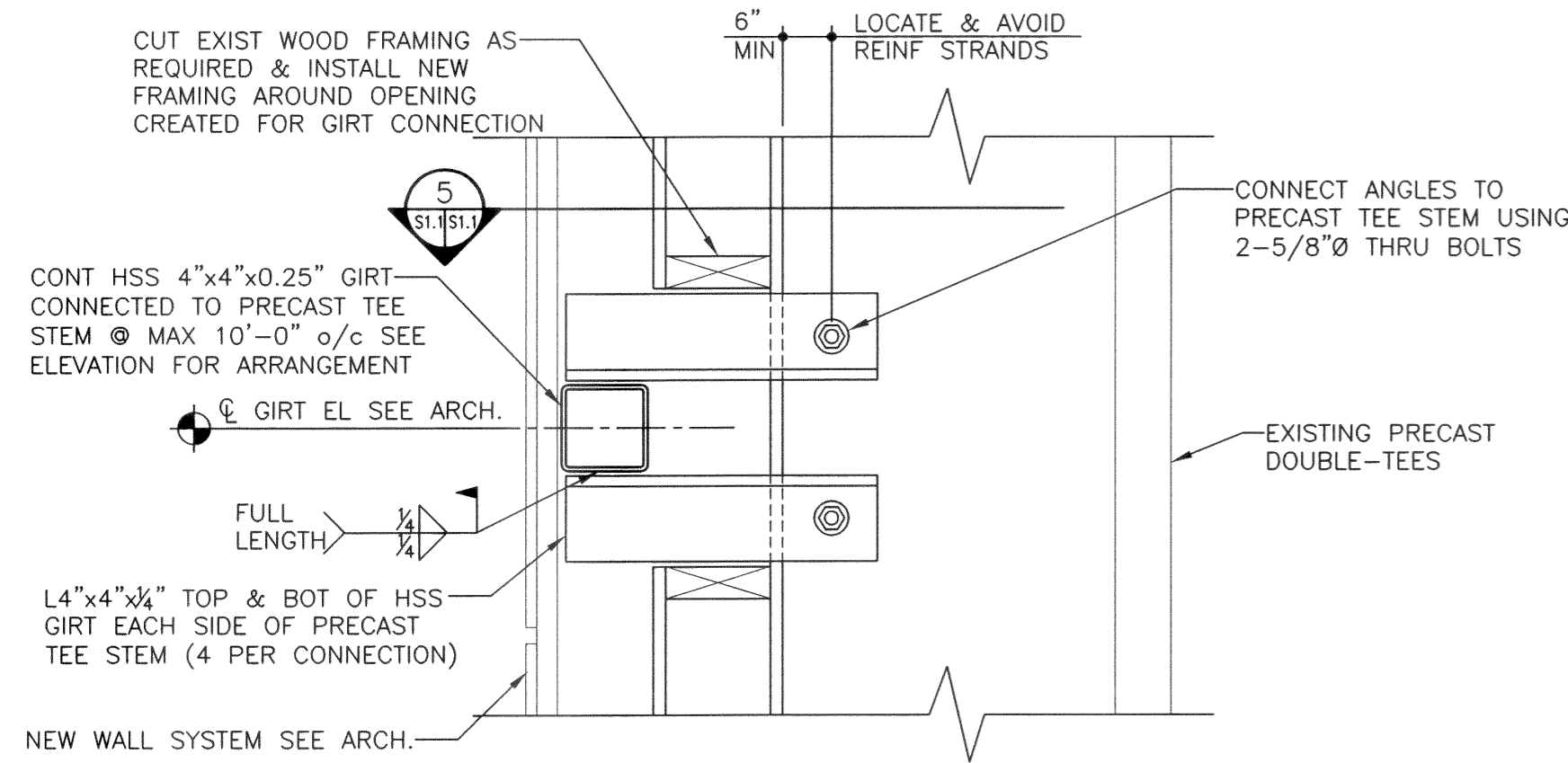

2 TYPICAL GIRTS DETAIL - BETWEEN SUPPORT CONNECTIONS  
SCALE: 1 1/2"=1'-0"

3 TYPICAL GIRTS DETAIL - AT SUPPORT CONNECTIONS  
SCALE: 1 1/2"=1'-0"

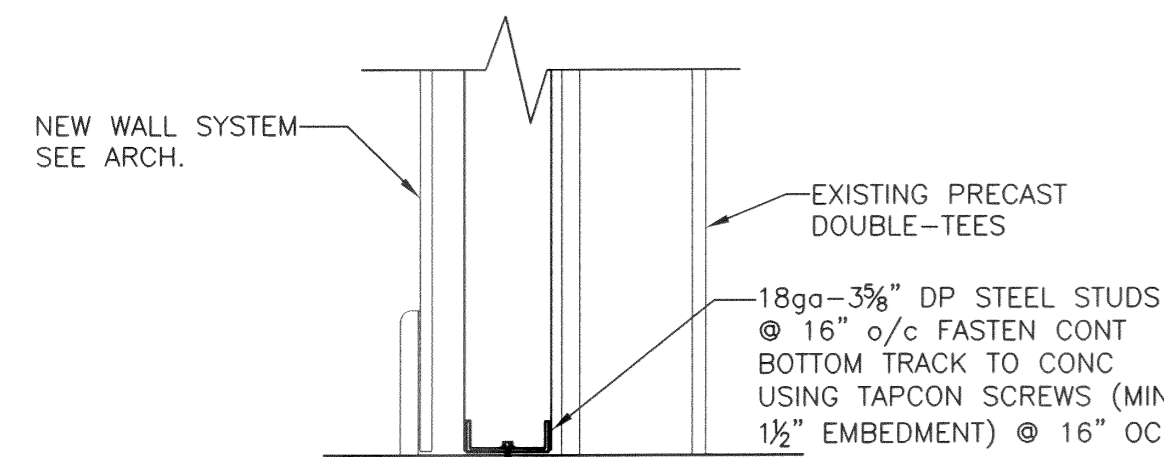

4 WALL BASE CONNECTION DETAIL  
SCALE: 1 1/2"=1'-0"

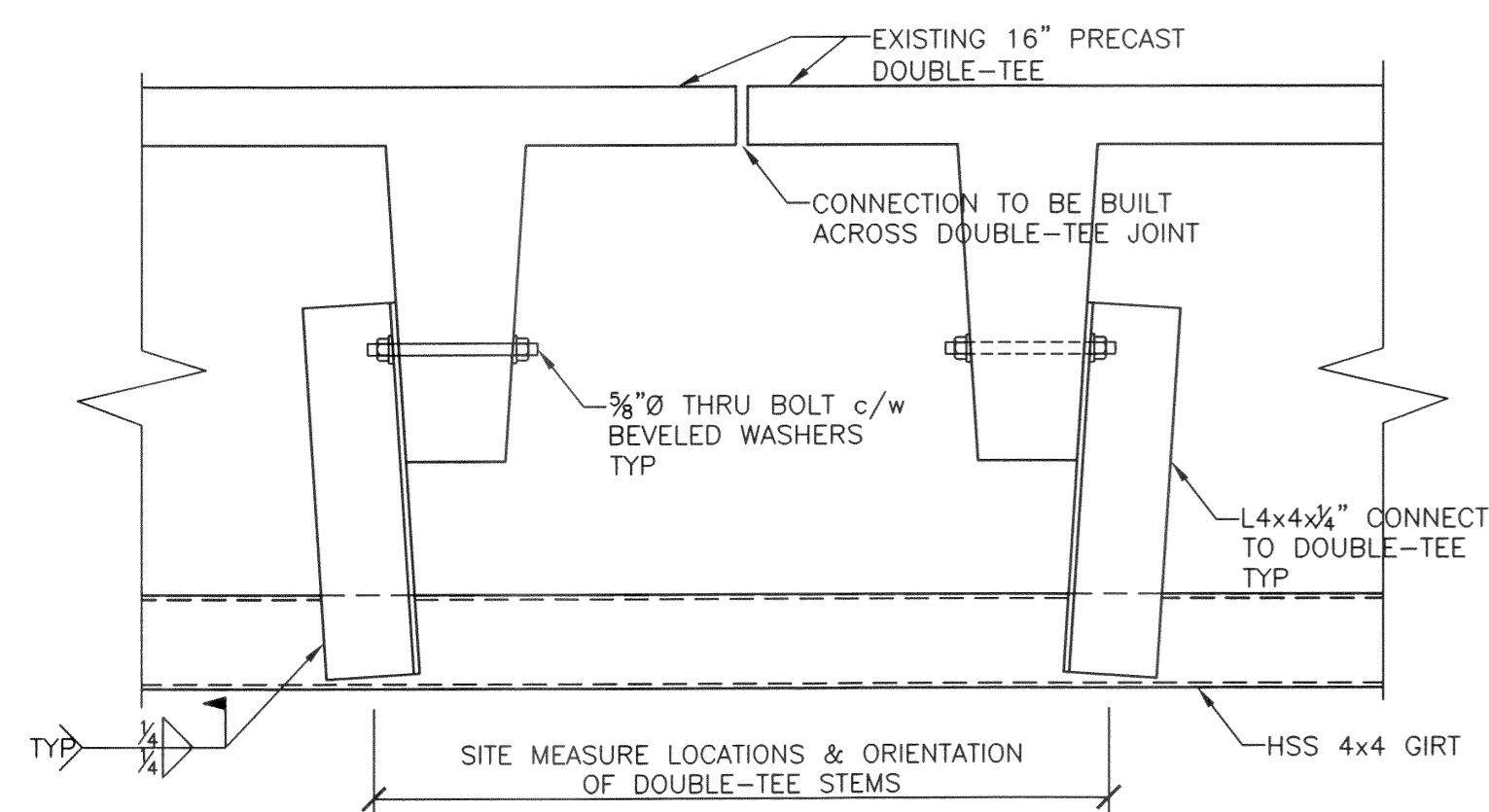

5 PLAN DETAIL  
SCALE: 1 1/2"=1'-0"

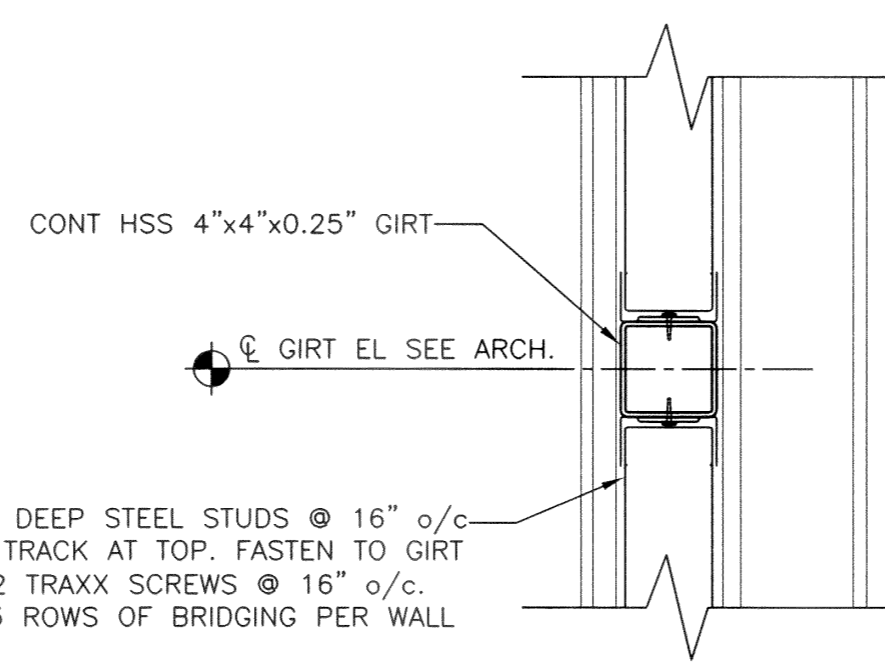

2 TYPICAL GIRTS DETAIL - BETWEEN SUPPORT CONNECTIONS  
SCALE: 1 1/2"=1'-0"

GENERAL NOTES

- STRUCTURAL DESIGN BASED ON THE MANITOBA BUILDING CODE OF CANADA 2005 EDITION.
  - IMPORTANCE CATEGORY: NORMAL
  - WIND LOAD: q50 = 9.4 P.S.F.
- DO NOT SCALE DRAWINGS.
- ALL DIMENSIONS ARE TO BE VERIFIED WITH THE ARCHITECTURAL DRAWINGS AND EXISTING SITE CONDITIONS PRIOR TO CONSTRUCTION.
- THESE STRUCTURAL DRAWINGS SHOW THE COMPLETED STRUCTURE AND DO NOT INDICATE ALL COMPONENTS NECESSARY FOR SAFETY DURING CONSTRUCTION. THE CONTRACTOR SHALL BE SOLELY RESPONSIBLE FOR SAFETY ON AND AROUND THE JOBSITE DURING CONSTRUCTION.

STRUCTURAL STEEL

- THE STRUCTURAL STEEL FABRICATOR'S ENGINEER SHALL BE RESPONSIBLE FOR LOCATING AND DESIGNING PROVISIONS FOR ALL TEMPORARY FALL PROTECTION SYSTEMS REQUIRED DURING CONSTRUCTION TO MEET MANITOBA WORKPLACE HEALTH AND SAFETY REGULATIONS.
- STRUCTURAL STEEL TO CONFORM TO CSA-G40.21, "STRUCTURAL QUALITY STEELS" AND CSA-G40.20 "GENERAL REQUIREMENTS FOR ROLLED OR WELDED STRUCTURAL QUALITY STEEL".
- ALL ROLLED OR STEEL STRUCTURAL SECTIONS SHALL BE G40.21-50W. ALL HOLLOW STRUCTURAL SECTIONS TO BE G40.21-50W CLASS C. ALL ANGLES, CHANNELS AND PLATES SHALL BE G40.21-44W.
- FABRICATION AND ERECTION OF STRUCTURAL STEEL SHALL BE PERFORMED IN ACCORDANCE WITH CAN/CSA S16.1-01, "STEEL STRUCTURES FOR BUILDINGS".
- ALL WELDING SHALL CONFORM TO THE LATEST EDITION OF CSA W59, "WELDED STEEL CONSTRUCTION". FABRICATORS SHALL BE PROPERLY CERTIFIED IN ACCORDANCE WITH CSA W47.1, "CERTIFICATION OF COMPANIES FOR FUSION WELDING OF STEEL STRUCTURES".
- ALL BOLTED CONNECTIONS TO USE A325 HIGH STRENGTH BOLTS. MINIMUM CONNECTION SHALL CONSIST OF 2 BOLTS.
- ALL STRUCTURAL STEEL IS TO RECEIVE ONE COAT OF CISC/CPMA 1-73a QUICK DRYING SHOP PRIMER. STEEL IN CRAWLSPACES SHALL RECEIVE 2 COATS. STEEL TO BE CLEANED IN CONFORMANCE WITH SSPC-SP2.
- FABRICATOR TO NOTIFY ENGINEER OF ANY PROPOSED MEMBER SUBSTITUTIONS AND CHANGED CONNECTION DETAILS.
- THE STRUCTURAL STEEL SUPPLIER SHALL PROVIDE AND BE RESPONSIBLE FOR ALL HOLES IN STEEL SECTIONS REQUIRED BY OTHER TRADES. SECTIONS SHALL BE STRENGTHENED WHERE REQUIRED TO GUARANTEE THE ORIGINAL STRENGTH OF THE BEAM. ANY CUTTING OF STEEL AT THE JOB SITE SHALL BE DONE ONLY AS DIRECTED AND APPROVED BY THE ENGINEER.
- STRUCTURAL STEEL SUPPLIER IS TO SUBMIT ENGINEERING DRAWINGS BEARING THE SEAL OF A PROFESSIONAL ENGINEER REGISTERED IN THE PROVINCE OF MANITOBA COVERING THE DESIGN OF CONNECTIONS, TO THE PROJECT DESIGN ENGINEER FOR REVIEW PRIOR TO FABRICATION. CONNECTION DESIGN TO INCLUDE FOR ALL ADJUSTABLE CONNECTIONS REQUIRED TO SUIT FABRICATION AND ERECTION PROCEDURES AND TOLERANCES.
- STRUCTURAL STEEL WHICH SUPPORTS ARCHITECTURAL FINISHES MUST BE DESIGNED TO BE SUFFICIENTLY ADJUSTABLE TO MEET REQUIRED INSTALLATION TOLERANCES. SEE ARCHITECTURAL FOR REQUIRED FINISH TOLERANCES.

CAST-IN-PLACE CONCRETE

- ALL CONCRETE IS TO BE MANUFACTURED AND INSTALLED IN ACCORDANCE WITH THE LATEST EDITION OF CAN/CSA-A23.1-04 "CONCRETE MATERIALS AND METHODS OF CONCRETE CONSTRUCTION" AND CAN/CSA-A23.2-04 "METHOD OF TEST FOR CONCRETE".
- PROVIDE CERTIFICATION THAT MIX PROPORTIONS SELECTED WILL PRODUCE CONCRETE OF QUALITY, YIELD AND STRENGTH AS SPECIFIED IN CONCRETE MIXES, AND WILL COMPLY WITH CAN/CSA-A23.1. CERTIFICATION LETTER TO BE SEALED BY A PROFESSIONAL ENGINEER REGISTERED IN THE PROVINCE OF MANITOBA.
- PROVIDE CERTIFICATION THAT PLANT, EQUIPMENT, AND MATERIALS TO BE USED IN CONCRETE COMPLY WITH REQUIREMENTS OF CAN/CSA-A23.1. CERTIFICATION LETTER TO BE SEALED BY A PROFESSIONAL ENGINEER REGISTERED IN THE PROVINCE OF MANITOBA.
- CONCRETE STRENGTH AT 28 DAYS SHALL BE AS FOLLOWS:

25 MPa MIN. AT 28 DAYS  
CLASS OF EXPOSURE: N  
ENTRAINED AIR/CATEGORY: NONE (LESS THAN 3%)  
AGGREGATE MAX. 20 mm  
CURING TYPE: 1 (SEE BELOW)

UNLESS INDICATED OTHERWISE THE CONTRACTOR SHALL SPECIFY CONCRETE SLUMP APPROPRIATE WITH PLACEMENT METHODS AND SITE CONDITIONS. THE CONTRACTOR-SPECIFIED SLUMP MUST BE SHOWN ON THE CERTIFICATION LETTER AND CONCRETE DELIVERY TICKET.

- CONCRETE CURING TO CONFORM TO THE LATEST EDITION OF CAN/CSA-A23.1-04 AS FOLLOWS UNLESS NOTED OTHERWISE ON THE DRAWINGS.
  - TYPE 1 - BASIC: 3 DAYS ≥ 10°C OR FOR A TIME NECESSARY TO ATTAIN 40% OF THE SPECIFIED STRENGTH.
  - TYPE 2 - ADDITIONAL: 7 DAYS ≥ 10°C OR FOR A TIME NECESSARY TO ATTAIN 70% OF THE SPECIFIED STRENGTH.
  - TYPE 3 - EXTENDED: 7 DAYS WET CURING ≥ 10°C.
- ALL REINFORCING STEEL TO BE CAN/CSA-G30.18M GRADE 400R DEFORMED BARS. ALL REINFORCING IS TO BE DETAILED IN ACCORDANCE WITH THE LATEST EDITION OF THE REINFORCING STEEL INSTITUTE OF CANADA - MANUAL OF STANDARD PRACTICE, EXCEPT OTHERWISE NOTED.
- ALL REINFORCING TO BE HELD IN PLACE, AND TIED BY THE USE OF PROPER ACCESSORIES, SUCH AS HI-CHAIRS, SPACERS, ETC. TO BE SUPPLIED BY THE REINFORCING STEEL FABRICATOR. HI-CHAIRS TO HAVE 4 LEGS AND TO BE STAPLED OR NAILED TO HARDBOARD TO AVOID PUNCTURING OR PENETRATING THE UNDERLYING RIGID INSULATION.
- VESTIBULE TOPPING SLAB TO BE REINFORCED WITH 10M BARS AT 16" O.C. EACH WAY MID-DEPTH.

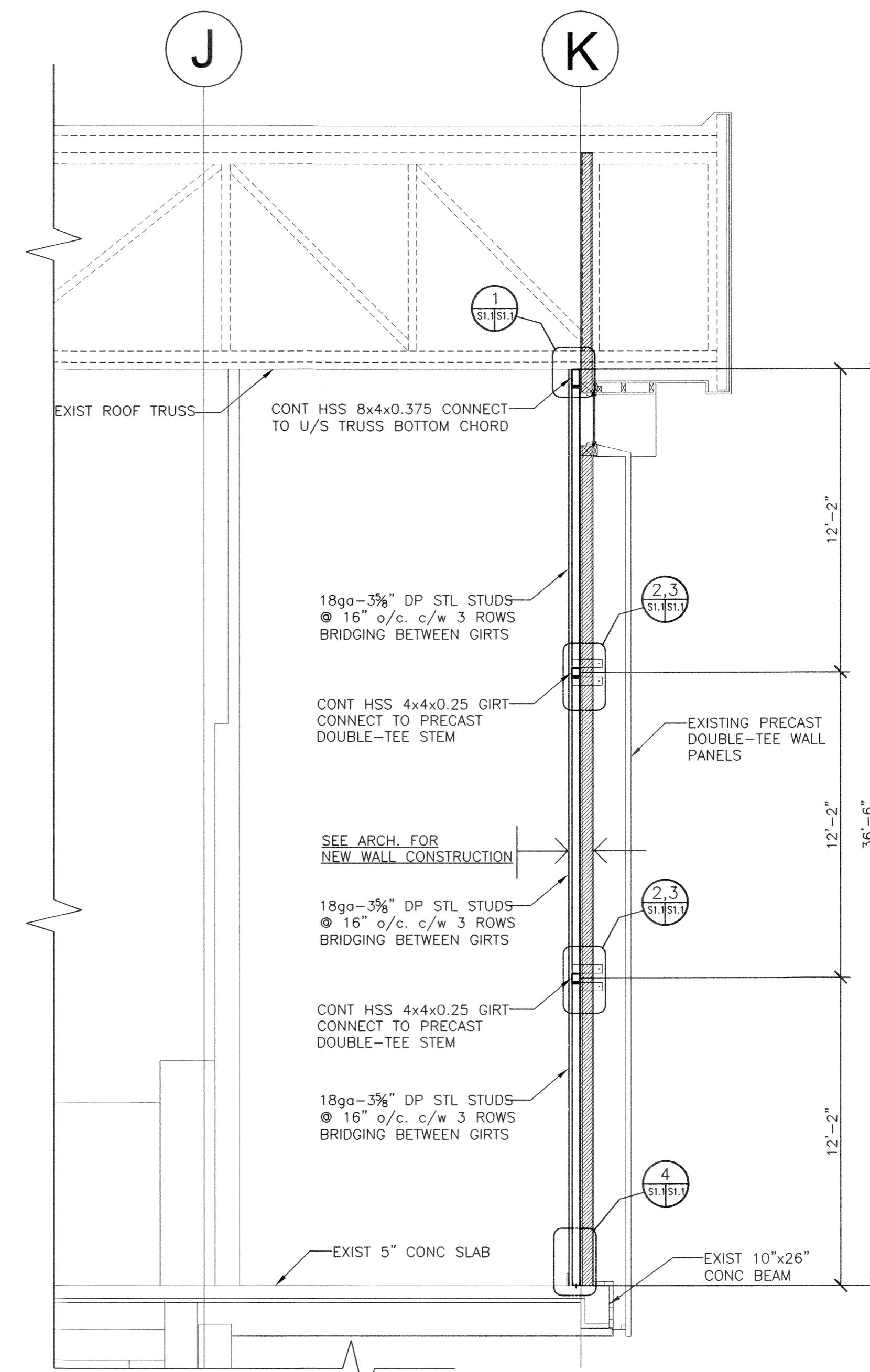

A WALL SECTION - PHASE 1  
SCALE: 1/4"=1'-0" PHASE 2 SIMILAR OPP.

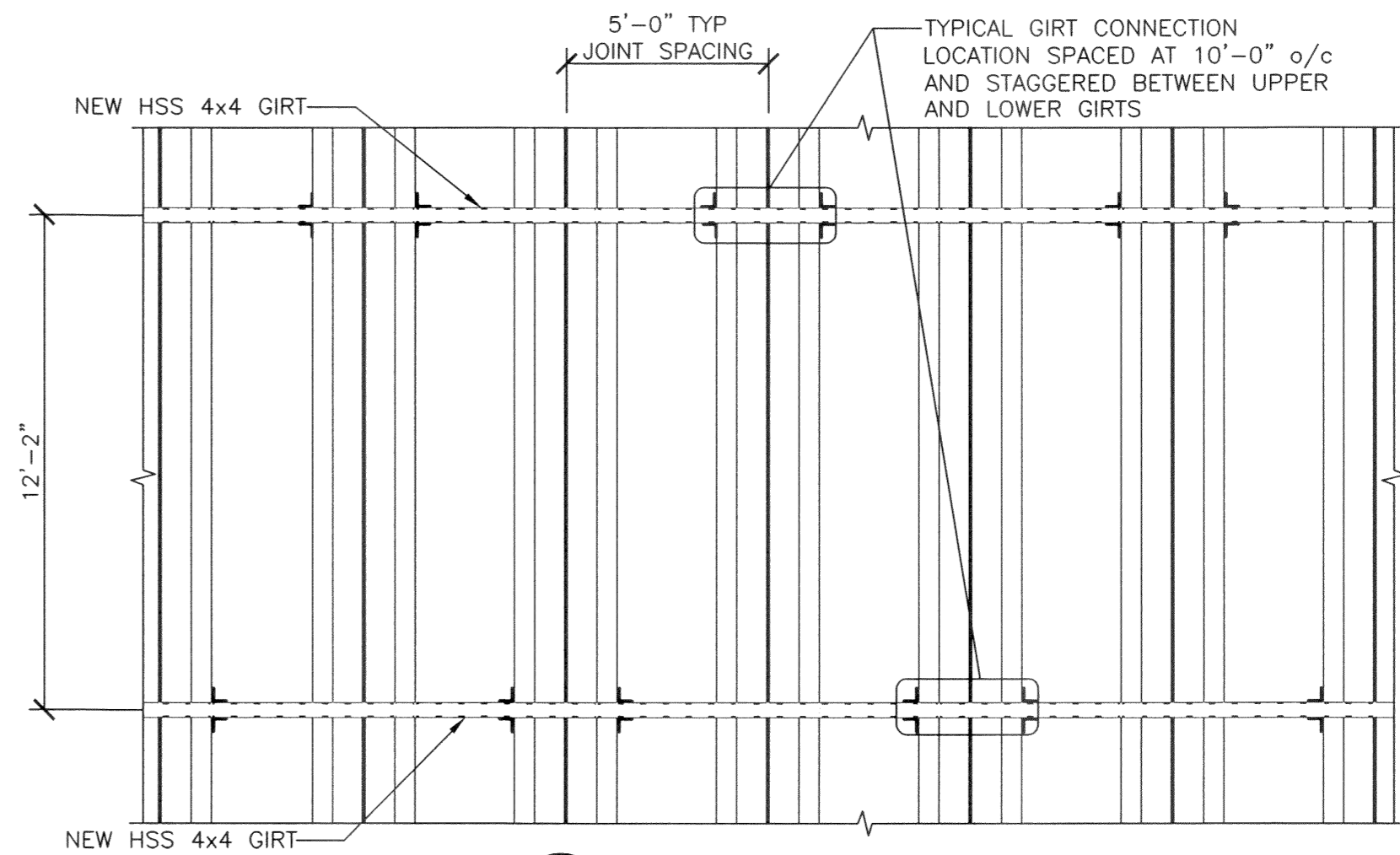

B PARTIAL WALL ELEVATION  
SCALE: 1/4"=1'-0"

0	ISSUED FOR TENDER	July 10, 2009	HJL
REV	DESCRIPTION	DATE	BY

**APEGM**  
Certificate of Authorization  
Crosier Kilgour & Partners Ltd.  
No. 235 Date: JULY 10, 2009

PROFESSIONAL ENGINEER  
H.J. LOUKA  
Member  
21527  
REGISTERED PROFESSIONAL ENGINEER

THIS DRAWING MUST NOT BE SCALED.  
THE GENERAL CONTRACTOR SHALL VERIFY ALL DIMENSIONS, DATUMS AND LEVELS PRIOR TO COMMENCEMENT OF WORK AND IS HELD RESPONSIBLE FOR REPORTING ANY DISCREPANCY OR OMISSION TO NEIL COOPER ARCHITECT INC. IMMEDIATELY.  
THIS DRAWING IS THE EXCLUSIVE PROPERTY OF NEIL COOPER ARCHITECT INC. AND CAN BE REPRODUCED ONLY WITH THE PERMISSION OF NEIL COOPER ARCHITECT INC. IN WHICH CASE THE REPRODUCTION MUST BEAR THEIR NAME AS THE ARCHITECTURAL FIRM.

STRUCTURAL WALL SECTIONS, DETAILS & GENERAL NOTES

PROJECT: PAN AM POOL  
BLDG ENVELOPE RETROFIT

25 Poseidon Bay, Winnipeg, Manitoba

Crosier Kilgour & Partners Ltd.  
CONSULTING STRUCTURAL ENGINEERS

Neil Cooper Architect Inc.  
10-395 Berry Street, Winnipeg, Manitoba R3J 1N6

Tuplin Group Inc.  
Unit L 301 Weston Street, Winnipeg, Manitoba R3E 3H4

DRAWN BY: MS	CHECKED BY: HJL	SHEET NO: S1.1R-0	REV NO:
DATE: JULY 10, 2009			
SCALE: As Noted			
FILE: 2009-0518			