

TABLE OF CONTENTS

	Pages
Section 00010 - Table of Contents	1
 Division 15 - MECHANICAL	
Section 15010 - Mechanical General Provisions.....	11
Section 15051 - Acceptable Materials & Equipment	1
Section 15180 - Insulation.....	4
Section 15800 - Air Distribution	16
Section 15900 - Controls/Instrumentation.....	7
Section 15990 - Testing, Adjusting & Balancing.....	4
 Division 16 - ELECTRICAL	
Section 16010 - Electrical General Requirements.....	14
Section 16111 - Conduits, Conduit Fastenings And Conduit Fittings.....	4
Section 16122 - Wires And Cables	5
Section 16131 - Splitters,Junction,Pull Boxes,Cabinets And CSTE's.....	2
Section 16132 - Outlet Boxes,Conduit Boxes And Fittings.....	3
Section 16151 - Wire And Box Connectors -0-1000 V.....	1
Section 16191 - Fastenings And Supports.....	2
Section 16192 - Mechanical Equipment Connections.....	2
Section 16195 - Work In Existing Building	2
Section 16440 - Disconnect Switches-Fused And Non-Fused Up To 1000 V.....	2
Section 16450 - Grounding - Secondary	3
Section 16477 - Moulded Case Circuit Breakers	1

END OF TABLE

Part 1 General

1.1 GENERAL

- .1 All Drawings and all sections of the Specifications shall apply to and form an integral part of this section.

1.2 SCOPE OF WORK

- .1 Work to include all labour, Material and equipment required for installing, testing and placing in initial operation the following systems as detailed in Specifications of each section and as shown on Drawings.
 - .1 Section 15051 Acceptable Materials & Equipment
 - .2 Section 15180 Insulation
 - .3 Section 15800 Air Distribution
 - .4 Section 15900 Controls/Instrumentation
 - .5 Section 15990 Testing, Adjusting and Balancing
- .2 All Mechanical Work to be Bid as a single complete Contract even though Work of various mechanical trades has been further sub-divided into each Section noted above.

1.3 EXISTING CONDITIONS

- .1 Examine Site, existing adjacent buildings and local conditions affecting Work under this contract. Examine Mechanical and Electrical and all other Contract Drawings to ensure Work can be performed without changes to the building as shown on plans. No allowance will be made later for necessary changes, unless notification of interferences have been brought to Contract Administrator's attention, in writing, in accordance with B4.

1.4 REGULATIONS

- .1 Comply with, most stringent requirements of Manitoba Building Code, National Building Code and local regulations and by-laws, with specified standards and codes and this Specification. Before any Work is proceeded with, approved layouts to be filed with and approved by proper authorities.
- .2 Provide necessary notices, obtain permits and pay all fees, in order that Work specified may be carried out. Charges and alterations required by authorized inspector of any authority having jurisdiction, to be carried out without charge or expense to City.
- .3 Furnish certificates confirming Work installed conforms to requirements of authorities having jurisdiction.

1.5 LIABILITY

- .1 Ducts and equipment installed improperly, to be removed and replaced without cost to City.
 - .2 Protect and maintain Work until building has been completed and accepted. Protect Work against damage during installation. Cover with tarpaulins if necessary. Repair all damage to floor and wall surfaces resulting from carrying out of Work, without expense to City.
-

- .3 During welding or soldering ensure structure is protected against fire by shielding, using fire-rated sheets and galvanized iron sheets. Contractor shall provide trained persons armed with suitable type extinguishers, with no other duties than to watch for and extinguish sparks, etc.
- .4 Co-ordinate Work with other sections to avoid conflict and to ensure proper installation of all equipment. Review all contract Drawings.
- .5 On completion of Work, remove tools, surplus and waste Material and leave Work in clean, perfect condition.

1.6 GUARANTEE

- .1 Guarantee satisfactory operation of all Work and apparatus installed under this Contract. Replace, at no expense to City, all items which fail or prove defective within a period of one year after final acceptance of complete Contract by City, always provided such failure is not due to improper usage by City. Make good all damage to building incurred as a result of failure or repair of mechanical Work.
- .2 No certification given, payment made, partial or entire use of equipment by City, shall be construed as acceptance of defective Work or acceptance of improper Materials. Make good at once, without cost to the City all such defective Work or Materials and consequence resulting therefrom, within one year of final acceptance date.
- .3 This general guarantee shall not act as a waiver for any specified guarantee and/or warranty of greater length of time noted elsewhere in these documents.

1.7 ENGINEERING OBSERVATIONS

- .1 The term "Contract Administrator" in all mechanical sections of Specification shall mean:

SMS Engineering Ltd.
770 Bradford Street
Winnipeg, Manitoba
R3H 0N3
- .2 Contractor's Work will be observed periodically by City, and/or Contract Administrator or their representatives, solely for purpose of determining general quality of Work, and not for any other purpose. Guidance will be offered to Contractor in interpretation of plans and Specifications to assist him to carry out Work. Observations and directives given to Contractor does not relieve Contractor and his agents, servants and employees of their responsibility to erect and install Work in all its parts in a safe and Workmanlike manner, and in accordance with plans and Specifications, nor impose upon City, and/or Contract Administrator or their representatives, any responsibility to supervise or oversee erection or installation of any Work.

1.8 WELDING REGULATIONS

- .1 Do not weld when temp. of base metal is lower than -17 deg. C except with consent of Contract Administrator. At temp. below 0 deg. C, surface of all areas within 75mm (3") of point where weld is to be started to be heated to temp. at least warm to hand before welding is commenced. At all temperatures below +4 deg. C, operator and Work to be protected against direct effect of wind and snow.
 - .2 Welding shall be performed by welder holding current welder's certificate from Provincial Department of Labour.
-

- .3 Comply with CSA W117.2 "Safety in Welding, Cutting, and Allied Processes".

1.9 MECHANICAL SHOP DRAWINGS

- .1 Submit for review a minimum of six sets of detailed Shop Drawings. Refer to Section 15051 "Acceptable Materials & Equipment" for Shop Drawings requirements.
- .2 Check Shop Drawings for conformity to plans and Specifications before submission.
- .3 Each Drawing to bear a signed stamp including project name and Contractor's Firm name verifying Drawings have been checked prior to submission to Contract Administrator. Signature of stamp shall signify the contractor has checked and found all dimensions to be compatible with the Contract Drawings and all capacities, quantities, sizes and other data contained in the Contract documents have been listed by the supplier on the Drawings and have been checked by the undersigned and found correct.
- .4 Clearly show division of responsibility. No item, equipment or description of Work shall be indicated to be supplied or Work to be done "By Other's or By Purchaser". Any item, equipment or description of Work shown on Shop Drawings shall form part of Contract, unless specifically noted to contrary.
- .5 Take full responsibility for securing and verifying field dimensions. In case where fabrication must proceed prior to field dimensions being available, check all Shop Drawings and approve for dimensions only. In this case guarantee that dimensions will be Worked to and ensure that other Subcontractors are aware of these dimensions and shall comply to them.
- .6 Review by Contract Administrator shall be mutually understood to refer to general design only. If errors in detailed dimensions or interference with Work are noticed, attention of Contractor will be called to such errors of interferences, but Contract Administrator's review of Drawings will not in any way relieve Contract Administrator from responsibility for said errors or interferences, or from necessity of furnishing such Work, and Materials as may be required for completion of Work as called for in Contract documents.

1.10 MECHANICAL SUBCONTRACTORS

- .1 Contractor to have minimum five years experience in field of mechanical contracting and to have successfully performed Work of similar nature and approximate size to that indicated in Specifications and on Drawings. Subcontractors shall employ, on this project, foremen or supervisory personnel who have had similar experience to that required of Contractor.

1.11 SCHEDULING OF WORK

- .1 Complete building to be occupied during term of this contract. Schedule new Work so normal functions within building are not unduly interrupted. In general, Work on the new areas to be performed during normal hours. Work in remainder of building to be scheduled so as to provide minimum of inconvenience to City. i.e. Perform Work either where areas are vacated during night period or at periods when it is permissible to Work in the existing areas to be approved by City. Suitable periods for shutting off mechanical services to be arranged with City's appointed representative. Perform Work requiring shutdown of air systems during night period or on weekends.
-

- .2 Existing buildings to be in use during construction of the addition. Arrange Work so that interruption of services is kept to minimum. Obtain permission from Contract Administrator, prior to cutting into mechanical services. Where deemed necessary by Contract Administrator, temporary piping to be installed, and/or Work to be carried out at night and on weekends.

1.12 DRAWINGS

- .1 Drawings are diagrammatic only and do not show all details. Information involving accurate measurements of building to be taken at building. Make, without additional expense to City, all necessary changes or additions to runs to accommodate structural conditions. Locations of ducts and other equipment to be altered without charge to City, provided change is made before installation and does not necessitate additional Materials and that all such changes are ratified by Contract Administrator, recorded on Record Set of Drawings.
- .2 Drawings and Specifications to be considered as an integral part of Contract Documents. Neither Drawings nor Specifications to be used alone. Misinterpretation of requirements of plans or Specifications shall not relieve Contractor of responsibility of properly completing Work to approval of Contract Administrator.
- .3 As Work progresses and before installing duct Work and equipment interfering with interior treatment and use of building, consult Contract Administrator for comments. If Contractor fails to perform above checking and fails to inform Contract Administrator of such interference, Contractor to bear all subsequent expense to make good the installation.
- .4 Drawings indicate general location and route to be followed by pipes and ducts. Where required ducts are not shown on plans or only shown diagrammatically, install in such a way as to conserve head room and interfere as little as possible with free use or space through which they pass.

1.13 MATERIALS

- .1 Materials and equipment specified and acceptable manufacturers are named in this Specification for the purpose of establishing the standard of Materials and Workmanship to which Contractor shall adhere. Bid price shall be based on the use of Materials and equipment as specified.
- .2
 - .1 Materials of same general type to be of same manufacture (e.g. all air supply units shall be of same manufacturer). Contractor to ensure that all Subcontractor provide products of same manufacturer.
 - .1 Follow manufacturer's recommendations for safety, adequate access for inspection, maintenance and repairs of individual equipment installed.
 - .2 Permit equipment maintenance and disassembly with minimum disturbance to connecting duct systems and without interference with building structure or other equipment.
 - .3 Provide accessible lubricating means for bearings, including permanent lubricated 'Lifetime' bearings.

- .3 Contractor may propose alternate for any specified item which Contractor considers equal to that specified. Substitutes or alternates must be submitted in accordance with B6. All alternate items submitted for consideration must not exceed available space limitations. All additional costs for mechanical and electrical, revisions required to incorporate Materials substituted by Contractor shall be responsibility of Contractor.
- .4 Equipment listed as 'equal' in Specifications or submitted as alternate by Contractor must meet all space requirements, specified capacities and must have equipment characteristics of specified equipment as interpreted by Contract Administrator. Install equipment in strict accordance with manufacturer's published recommendations.
- .5 Equipment and Materials shown on Drawings and not specified herein, or specified herein and not shown on Drawings, shall be included in this contract as though both shown and specified.

1.14 REMOVAL AND DISCONNECTION OF CITY'S EXISTING EQUIPMENT

- .1 All mechanical equipment conflicting with new equipment being installed to be removed or disconnected by Contractor shall remain property of City. Remove ducts not required in revised systems and interfering with new installation which shall become property of Contractor.

1.15 ELECTRIC MOTORS, STARTERS AND WIRING

- .1 Provide electric motors for all equipment supplied in this Division. Motors to operate at 29 r/S (1800 rpm), unless noted otherwise. Motor design shall comply with Canadian Electrical Code requirements. All electric motors supplied shall be capable of being serviced locally.
 - .2 All three phase motors shall have a service factor of 1.15 times nominal rated horsepower of the motor.
 - .3 Operating voltages: to CAN3-C235-83, motors, electric heating, control and distribution devices and equipment to operate satisfactorily at 60 Hz within normal operating limits established by above standard. Equipment to operate in extreme operating conditions established in above standard without damage to equipment.
 - .4 Motors controlled by variable frequency drives (VFDs) shall comply with requirements of CSA Specification C22.2 No. 100-95, Clause 12.4 and shall be permanently marked with the following in addition to the normal marking requirements:
 - .1 Machine Application (Inverter Duty);
 - .2 Speed range over which the machine is designed to operate;
 - .3 Type of torque application for which the machine is designed (e.g. VT (variable torque), CT (constant torque), Chp (constant horsepower) or equivalent in accordance with B6.
 - .4 Type(s) of inverter(s) with which the machine is intended to be used [e.g.: VSI or VVI (6-step voltage source), CSI (6-step current source), VPWM (voltage-source pulse width modulated), LCI (load commutated), cyclonverter, or equivalent in accordance with B6].
 - .5 Motors 0.75 kW (1 hp) and larger shall be high efficiency motors as defined in CSA C390 or IEEE 112B Nominal Standards. Minimum efficiency (%) shall be per the following table.
-

kW	Minimum efficiency (%)			
	3600 RPM	1800 RPM	1200 RPM	900 RPM
.75	79.0	82.4	81.1	74.4
1.11	81.0	82.8	83.8	76.8
1.50	81.7	83.8	84.4	83.8
2.24	84.6	86.1	86.4	83.6
3.73	86.4	86.9	87.2	85.4
5.60	87.4	88.4	88.2	86.2
7.46	88.4	89.4	88.6	88.6
11.19	89.3	90.1	89.0	88.0
14.92	89.7	90.9	89.8	89.8
18.65	90.0	91.1	90.9	89.6
22.38	90.6	91.5	91.1	90.3
29.84	91.0	92.0	91.6	90.1

List information on shop Drawing submittals

- .6 Determine from electrical Drawings and Specifications, voltage characteristics applying to each individual motor. Where motor voltages are mentioned in this Specification, confirmation to be made by reference to electrical Drawings and Specifications ordering motors.
- .7 Division 16 - Electrical to provide starters for all motors, except as otherwise noted. Division 16 - Electrical shall wire from starters to motors.
- .8 Wiring required between starters and switching apparatus such as wiring from starters to float switches, pressure switches and all control wiring to be by Division 16 - Electrical except as noted otherwise on Drawings and in Specifications. Provide proper terminal connections and lead wires at motors and other apparatus ready for connection by Division 16 - Electrical. Provide Division 16 - Electrical with accurate locations of electrical connection points and all necessary schematic and other Drawings to facilitate electric Work.
- .9 Wiring required under Section 15900 to be performed by Section 15900 except as noted otherwise. Refer also to Section 15900 for further requirements.
- .10
 - .1 Division 16 - Electrical to perform all wiring and make final connections to all controls for roof-top HVAC units and all mechanical equipment where controls are supplied with equipment.
 - .2 Division 15 shall provide wiring diagrams indicating all power and control wiring requirements.
- .11 Division 15 shall provide wiring diagrams indicating all power and control wiring requirements for equipment supplied by Division 15.

1.16 HANGERS AND SUPPORTS

- .1 General
 - .1 Piping, ductWork and equipment shall be securely supported from building structure. Perforated strap or wire hangers are not permitted.
 - .2 Support components shall conform to Manufacturers Standardization Society Specification SP-38.

1.17 SUPPORTS, BASES, PITS

- .1 Supply and erect all special structural Work required for installation of fans, motors and other apparatus.
- .2 Concrete pads, concrete for floating bases, curbs and pits to be supplied under Division 3. Supply all anchor bolts, fasteners and foundation Drawings. Unless noted otherwise, all major pieces of equipment such as pumps, compressors, fans, etc. to be mounted on 150mm (6") concrete pad.
- .3 Mount equipment suspended above floor level but not detailed on platform bracketted from wall. Where wall thickness is inadequate to permit such brackets, carry supports to either ceiling or floor, or both as required.

1.18 FLASHING

- .1 Where pipes or ducts go through a roof or wall, they should be boxed-in and flashed as per Division 3. Allow for expansion and contraction of pipe. Flashing shall be waterproof.

1.19 IDENTIFICATION OF EQUIPMENT

- .1 Provide manufacturer's nameplate on each piece of equipment.
- .2 In addition Mechanical Contractor shall provide equipment I.D. tag minimum size 87mm x 32mm x 2.3mm (3-1/2" x 1-1/2" x 3/32") nominal thickness laminated phenolic plastic with black face and white centre. Engraved 6mm (1/4") high lettering. For motors and controls and for larger equipment such as chillers, tanks, 25mm (1") high lettering; for hot equipment such as boilers and convertors, provide engraved brass or bronze plates with black paint filled identification.
- .3 Identify as follows: equipment type and number (e.g. pump no. 2), service or areas or zone building served (e.g. south zone chilled water primary).
- .4 Provide manufacturers' registration plates (e.g. pressure vessel, Underwriters' Laboratories and CSA approval plates) as required by respective agency and as specified.

1.20 MECHANICAL EQUIPMENT GUARDS

- .1 Meet safety requirements of Provincial Department of Labour and local authorities having jurisdiction.
 - .2 Guards for drives shall have:
 - .1 No. 2.5mm (12 US std. ga.) galv. 18mm (3/4") mesh wire screen welded to steel angle frame.
 - .2 No. 1.2mm (18 US std. ga.) galv. sheet metal tops and bottoms.
 - .3 Removable sides for servicing.
 - .3 For flexible couplings, provide removable, 'U' shaped, 2.5mm (12 ga.) galv. frame and 1.2mm (18 ga.) expanded mesh face.
 - .4 Provide means to permit lubrication and use of test instruments with guards in place.
 - .5 Install belt guards to permit movement of motors for adjusting belt tension.
 - .6 Provide 18mm (3/4") mesh wire screen on inlet or outlet of exposed fan blades.
 - .7 Provide 37mm (1-1/2") diameter hole on shaft centre for insertion of tachometer.
-

1.21 SCREWS, BOLTS AND FASTENERS

- .1 Use standard commercial sizes and patterns with Material and finish suitable for service.
- .2 Use heavy hex heads, semi-finished unless otherwise specified. Use type 304 stainless steel for exterior areas.
- .3 Bolts used on fan equipment for access to motors, bearings, filters and the like shall be heavy-duty.
- .4 Bolts shall not project more than one diameter beyond nuts.
- .5 Washers
 - .1 Use plain-type washers on equipment, sheet metal and soft gaskets, lock-type washers where vibration occurs, and resilient washers with stainless steel.

1.22 SPECIAL TOOLS AND SPARE PARTS

- .1 Provide one set of all specialized tools required to service equipment as recommended by manufacturers.
- .2 Furnish one grease gun and adaptors to suit different types of grease and grease fittings.

1.23 OPENINGS IN FIRE SEPARATIONS

- .1 Provide firestopping for all openings in fire separations for passage of pipes, ducts, etc. to maintain integrity of fire separations.
- .2 Firestopping
 - .1 Firestopping to be Dow-Corning Fire Stop System.
 - .2 Material shall be Dow-Corning silicone elastomer Fire Stop penetration Seal and/or Dow-Corning liquid silicone elastomer Fire Stop Foam of density, width and depth to maintain assembly fire resistive rating.
 - .3 Components shall be ULC listed.
- .3 Installation
 - .1 Prepare all surfaces so they are clean, dry, and frost free, as per manufacturer's published recommendations.
 - .2 Use Sealant around single pipes and/or ducts.
 - .3 Use Foam for multiple pipe installation.
 - .4 Follow manufacturer's published installation instructions precisely including field quality control after installation.
 - .5 Submit to Contract Administrator, suitable document signed by manufacturer's local representative, stating:
 - .1 Div. 15 sub-contractor received sufficient installation instruction from manufacturer's representative.

1.24 TRIAL USAGE

- .1 City reserves right to use any piece of mechanical equipment, device or Material installed under this contract, for such reasonable lengths of time and at such times as Contract Administrator may require, to make complete and thorough test of same, before final completion and acceptance of any part of contract. It is agreed and understood, that no claim for damage will be made for any injury or breakage to any part or parts of the above due to aforementioned tests, whether caused by weakness or inaccuracy of parts, or by defective Materials or Workmanship of any kind whatsoever. Supply all labour and equipment for such tests.
-

1.25 SAFETY DEVICE TESTING

- .1 Make complete inspection of all safety devices to ensure:
 - .1 That safety devices are complete and in accordance with Specifications and manufacturer's recommendations.
 - .2 That the safety devices are connected and operating according to all local regulations.
- .2 On completion of inspections, supply to Contract Administrator letters and/or certificates for their record, confirming that inspections have been completed.

1.26 TEMPORARY USE OF EQUIPMENT

- .1 Permanent systems and/or equipment not to be used during construction period, without Contract Administrator's written permission.
- .2 Heating systems may be used for temporary heating within limitations specified under clause 'Temporary Heating'. Refer also to 'General Conditions'.
- .3 Equipment used during construction period to be thoroughly cleaned and overhauled. Replace worn or damaged parts so equipment is in perfect condition, to entire satisfaction of Contract Administrator and City.
- .4 Provide proper care, attention and maintenance for equipment while it is being used. If, in opinion of Contract Administrator, sufficient care and maintenance is not being given to equipment and systems, Contract Administrator reserves right to forbid further use of said equipment and systems.
- .5 Temporary use of equipment shall in no way relieve Contractor of providing twelve month guarantee on all equipment so used this guarantee period to commence as of date of final acceptance of building by City as interpreted by Contract Administrator.

1.27 RECORD DRAWINGS

- .1 Provide one set of Contract prints to form Record Drawings, marked clearly with all changes and deviations from piping and ductwork, including all Contract Changes.
- .2 Use different colour ink for each service.
- .3 Update Record Drawings on a regular basis to ensure they are accurate, and have available for reference and inspection at all times.
- .4 This information will be used by others to create Record Drawings on CAD.

1.28 INSTRUCTIONS TO CITY'S PERSONNEL

- .1 In addition to start-up supervision and instruction of City's personnel required of individual equipment manufacturers and systems as noted, Contractor's construction supervisor to instruct City's personnel in operation and maintenance of all equipment and systems to satisfaction of Contract Administrator.
 - .2 Provide City with four copies of manuals incorporating following:
 - .1 Service instructions - including lists of spare and replacement parts and names and addresses of suppliers.
 - .2 Maintenance & Operating instructions.
 - .3 Revised Shop Drawings.
-

- .3 Forward manuals to Contract Administrator for review. Final payment will not be made until all required manuals have been received.
- .4 Review instructions with City's representative to ensure City's representative has a thorough understanding of equipment and its operation.
- .5 Contractor shall submit to Contract Administrator, suitable document signed by City's representative, stating:
 - .1 City has received satisfactory instruction in operation and maintenance of all equipment and systems.
 - .2 Operation and maintenance manuals have been reviewed with City.
 - .3 Specified spare parts, keys, removable handles and the like, have been turned over to City.

1.29 IDENTIFICATION OF DUCTWORK

- .1 Use black 50mm (2") high stencilled letters (e.g. "Cold", "Hot", "Return", "Sanitary Exhaust", "Kitchen Exhaust") with arrow indicating air flow direction.
- .2 Distance between markings 15m (50') maximum.
- .3 Identify ducts on each side of dividing walls or partitions and beside each access door.
- .4 Stencil only over final finish.
- .5 Prior to installation, review general application of identification with Contract Administrator.

1.30 CUTTING AND PATCHING

- .1 Cutting, patching and repairs to existing surfaces required as a result of the removal and/or relocation of existing equipment and piping, and/or installation of new equipment and piping in existing building to be included by Div. 15 - Mechanical in Bid price. Division 15 - Mechanical to employ and pay appropriate Subcontractor whose Work is involved, for carrying out Work described above.
- .2 Div. 15 - Mechanical to perform all cutting only of existing surfaces as required as a result of the removal and/or relocation of existing equipment and piping and/or installation of new equipment and piping in the existing building to be included in the Bid price.
 - .1 If, in the opinion of Contract Administrator, cutting of holes has been improperly performed (i.e. too large for ducts) Division 15 - Mechanical to do all patching as per original Specifications and all costs will be borne by him.
- .3 Where services are concealed within walls, floors or ceilings and cannot be visually identified, Contractor shall provide electronic scanning devices or other approved means to locate and identify concealed services prior to drilling.

1.31 SALVAGE

- .1 All usable salvaged equipment and Materials shall remain the property of the City unless specifically noted otherwise. Such Material shall be neatly stored on site for removal by the City. Contractor shall remove all rejected salvage from the site and legally dispose of it.

END OF SECTION

Part 1 General

1.1 GENERAL

- .1 Following Appendix of Manufacturers lists manufacturers of equipment and Materials acceptable to Contract Administrator, subject to individual clauses under the various sub-sections of Mechanical Work Specifications. See item 'Materials' under this section of Specification.
- .2 Product noted in individual Specification clauses is an item that meets Specification in all respects regarding performance, quality of Material and Workmanship, and is acceptable to Contract Administrator without qualification. Equipment proposed from other manufacturers listed as 'Approved Manufacturers' and alternates shall meet same standards.
- .3 Submit Shop Drawings for all items marked with asterisk(*).
- .4 Request for equals must be received in Contract Administrator 's office no later than seven (7) Working days prior to close of Bid Opportunity.

1.2 EQUIPMENT OR MATERIAL & APPROVED MANUFACTURERS

.1 ELECTRIC MOTORS

- .1 G.E.; Siemens; Tamper; Reliance; Leland; Lincoln; U.S. Electric; Century; Baldor; WEG; Toshiba

.2 INSULATION

- .1 External Duct Insulation Manville; Fibreglas; Knauf

.3 AIR DISTRIBUTION

- .1 Ducturns, damper hardware, fan connections* Duro-Dyne
- .2 Duct Sealer Duro-Dyne; 3M; Flexa-Duct; United; Bakelite
- .3 Centrifugal exhaust fan Cincinati Fan (pre-purchased)
- .4 Backdraft damper* Penn; Greenheck; Ventex
- .5 Exhaust Rail System* Nederman
(all components)

.4 CONTROLS/INSTRUMENTATION

- .1 Variable Frequency Drive (VFD)* ABB
- .2 Flow switch*
 - .1 (Air) Cleaveland Controls AFS-222
- .3 Flow sensors*
 - .1 (Fluid) Engineering Measurements Co.

.5 H.V.A.C. BALANCE AND TESTING

- .1 H.V.A.C. Balance & Testing Agency Airdronics Inc.; DFC; AHS; Air Movement Services

END OF SECTION

Part 1 General

1.1 GENERAL

- .1 All Drawings and all sections of the Specification shall apply to and form an integral part of this section.

1.2 WORK INCLUDED

- .1 Labour, Material, plant, tools, equipment and services necessary and reasonably incidental to completion of external insulation for mechanical equipment, ductWork.

1.3 RELATED WORK SPECIFIED ELSEWHERE

- .1 Section 15010 Mechanical General Provisions
- .2 Section 15051 Acceptable Materials & Equipment
- .3 Section 15800 Air Distribution

Part 2 Products

2.1 MATERIALS

- .1 All Materials shall be equivalent in all respects to specified products and shall be used only in applications intended by the manufacturer. Materials not specifically intended for the purpose shall not be used. Approved Materials shall not be diluted or blended with other Materials unless specifically recommended by the manufacturer of the approved Material.
- .2 All final duct installations including insulation, covering and adhesive shall have a ULC Certified flame spread rating of not greater than 25, and a smoke developed classification of not more than 50.
- .3 All canvas shall be treated to be fire retardant in accordance with ULC standards.
- .4 Wire to be 1.2mm (18 ga.) stainless steel, dead soft annealed, type 304.
- .5 U.L.C. label or satisfactory certified report from approved testing laboratory is required to indicate that fire hazard ratings for Materials proposed for use do not exceed those specified.
- .6 Flameproofing treatments subject to deterioration due to effects of high humidity are not acceptable.
- .7 Contract Administrator reserves the right to demand test samples of components of insulation systems for fire hazard test rating.

2.2 COMPATIBILITY OF COMPONENTS

- .1 All adhesives, sealers, vapour coating, mastics, laggings and bedding compounds, shall be compatible with Materials to which they are applied. They shall not soften, corrode, or otherwise attack such Material in either wet or dry state and shall only be those recommended by manufacturer of insulation as suitable for application proposed. They shall be applied at ambient conditions acceptable to the manufacturer.

2.3 VAPOUR BARRIER FLEXIBLE DUCT INSULATION

- .1 Following duct externally insulated with Fibreglas RFFRK reinforced foil-faced vapour seal duct insulation PF335, 340 g. (3/4 lb./cu. ft.) density.
 - .1 25mm (1") Thickness
 - .1 All round supply air ductWork, and all rectangular supply air ductWork, less than 1200mm (48") wide on discharge of fan systems with cooling coils.
 - .2 All supply air ductWork on discharge of fan , , .
 - .3
 - .2 50mm (2") Thickness
 - .1 All round exhaust and relief ducts, supply and return air ducts from/to RTUs not shown acoustically lined from roof or wall back for a length of 1.8m (6'-0") or from wall or roof discharge back to damper, whichever is greater.
 - .2 All round roof ducting to centrifugal exhaust fans located on roofs.
 - .3 All outside air ductWork.
 - .4 All dust collector ductWork from wall or roof back into building for distance of 1.8m (6'-0").
 - .5 When duct pass through cold attic spaces, vapour barrier on insulation should be eliminated.

2.4 VAPOUR BARRIER RIGID INSULATION

- .1 Following ducts externally insulated with Fibreglas RFFRK reinforced foil-faced vapour seal duct insulation type FF 340 g. (4.5 lb./cu.ft.) density.
 - .1 25mm (1") Thickness
 - .1 All rectangular supply air ductWork, greater than 1200mm (48") wide, on discharge of fan systems with cooling coils.
 - .2 All rectangular supply air ductWork on discharge of fan , , .
 - .2 50mm (2") Thickness
 - .1 All rectangular exhaust and relief ducts, supply and return air ducts from/to RTUs not shown acoustically lined from roof or wall back for a length of 1.8m (6'-0") or from wall or roof discharge back to damper, whichever is greater.
 - .2 All rectangular roof ducting to centrifugal exhaust fans located on roofs.
 - .3 All outside air ductWork.

Part 3 Execution

3.1 VAPOR BARRIER FLEXIBLE DUCT INSULATION

.1 Rectangular DuctWork

- .1 On ducts 600mm (24") wide and wider apply fasteners to bottom surface of duct by impaling on welded pins on 300mm (12") centres. Spot adhesive on 300mm (12") centres on all sides of duct. Apply insulation with edges tightly butted together and secured with 100% coverage of 3-M No. 17 or approved alternate in accordance with B6. Staple joints and seal with 100mm (4") strips of vapor barrier foil of same quality as duct insulation membrane sealed with BF85-15.
- .2 On ducts 575mm (23") wide or less insulation applied as above but welded pins may be omitted.

.2 Round Ducts

- .1 Adhere to duct surface applied in strips 150mm (6") wide, 300mm (12") o.c. Butt all edges of insulation, staple and seal all joints with tape adhered over the joint. Seal all breaks with vapor barrier type.

.3 Exposed Ducts

- .1 Recover ducts exposed to view with 170 g. (6 oz.) canvas secured with Bakor 120-18 white fire retardant lagging adhesive. Finish with brush coat of same adhesive.

.4 Outdoor Ducts

- .1 On roof and other ductWork located outside of building, provide 26 ga. G.I. sheet metal cover to protect insulation. Seal all joints and make weathertight.
- .2 On square or rectangular ductWork provide slight peak along top centre line so moisture will run off.

3.2 VAPOR BARRIER RIGID DUCT INSULATION

- .1 Insulation applied with edges tightly butted and secured by impaling on pins welded to duct. Pins to be staggered, minimum 300mm (12") o.c. in every direction. This applies to all sides. Secure insulation to pins with metal fasteners. Pins shall be long enough to bend after fasteners have been applied. Install two fasteners to all insulation on roof. Dab adhesive over pins and fasteners.

- .2 Seal all joints, edges and breaks in vapor seal jacket with vapor barrier foil of the same quality as that of duct membrane 100mm (4") wide with BF 85-15 lagging adhesive.

.3 Exposed Ducts

- .1 Recover ducts exposed to view with 170 g. (6 oz.) canvas secured with Bakor 120-18 white fire retardant lagging adhesive. Finish with brush coat of same adhesive.

.4 Outdoor Ducts

- .1 On roof and other ductWork located outside of building, provide 26 ga. G.I. sheet metal cover to protect insulation. Seal all joints and make weathertight.

- .2 On square or rectangular ductwork provide slight peak along top centre line so moisture will run off.

END OF SECTION

Part 1 General

1.1 GENERAL

- .1 All Drawings and all sections of the Specifications shall apply to and form an integral part of this section.

1.2 WORK INCLUDED

- .1 Labour, Materials, plant, tools, equipment and services necessary and reasonably incidental to completion of air conditioning and/or ventilation Work.

1.3 RELATED WORK SPECIFIED ELSEWHERE

- .1 Section 15010 Mechanical General Provisions
- .2 Section 15180 Insulation
- .3 Section 15900 Controls/Instrumentation
- .4 Section 15990 Testing, Adjusting and Balancing
- .5 Section 16010 Electrical General Provisions

Part 2 Products

2.1 DUCT OPENINGS

- .1 Pack area between ducts and openings with fireproof self-supporting insulation. Seal with 25mm (1") mastic topping.
- .2 Use 1.2mm (18 ga.) galv. iron sleeves where ductWork passes through mechanical room. Sleeves to extend 150mm (6") above floor. Use watertight mastic between sleeve and floor Material.

2.2 DUCT AND EQUIPMENT SUPPORTS, HANGERS AND INSERTS

- .1 Support horizontal ducts on maximum 2.4m (8'0") centres by non perforated galv. steel, rivetted strap for ductWork 900mm (36") (either dimension) or less, and minimum 25mm x 25mm x 3mm (1" x 1" x 1/8") galv. angle iron passing under ducts 925mm (37") or over (either dimension) with 9.4mm (3/8") diam. threaded rods suspending angles from structure.
 - .2 Support vertical ducts at every floor with angle iron collars sized to provide proper bearing.
 - .3 Use universal concrete type inserts of black malleable iron, for threaded connection with lateral adjustment, top slot for reinforcing rods and lugs for attaching to forms.
 - .4 Where inserts must be placed in existing concrete use Hilti H.K.D. steel anchors as recommended by manufacturer, or if heavy weights must be supported, drill hole through
-

slab and provide 50mm x 50mm (2" x 2") washer and nut above rough slab before floor finish is poured.

- .5 To Steel Beams: Where pipe size is 50mm (2") or less, Grinnell Fig. 87 Malleable Iron C-Clamp and Retaining Clip, or equal. Where pipe size is over 50mm (2"), use Grinnell Fig. 229 Malleable Beam Clamp or Fig. 228 Forged Steel Beam Clamp.
- .6 To Wooden Ceilings and Beams: Grinnell Fig. 153 Pipe Hanger Flange or Fig. 156 or equal.
- .7 Support hangers in corrugated steel deck by 50mm (2") wide piece of 3mm (1/8") thick steel plate across top of steel deck, secured to hanger rod by washer and nut; prior to pouring of concrete topping.

2.3 HIGH PRESSURE DUCTWORK

- .1 Rectangular DuctWork
 - .1 Constructed of not less than 1.2mm (#18 ga.) galv. iron sheets. Construction generally to follow clause 'Low Pressure DuctWork'. Seams and joints to have continuous weld. Support from 50mm (2") x 50mm (2") x 6mm (1/4") galv. iron angles, placed on 1.2m (4'-0") o.c., bolted to perimeter reinforcing angles.
 - .2 Max. Side Bracing

Up to 36"	1" x 1" x 1/8" on 48" centres
36" to 96"	1-1/2" x 1-1/2" x 1/4" on 24" centres
Over 96"	2" x 2" x 1/4" on 24" centres
- .2 Round DuctWork
 - .1 Sizes up to 914mm (36") to be zinc-coated steel strip, spiral conduit or round.
 - .2 Construct spiral sizes up to 203mm (8") of .50mm (#26 ga.) with ribs spaced 63mm (2-1/2") to 100mm (4") apart. Sizes from 228mm (9") to 609mm (24") to be of .60 (#24 ga.) with ribs spaced 150mm (6") apart. Sizes 660mm (26") to 914mm (36") of .80 (#22 ga.) with ribs spaced 150mm (6") apart.
 - .3 Round duct to have grooved longitudinal seams with continuous weld.
 - .4 Sections joined by 200mm (8") coupling sleeves.
 - .5 Fitting manufactured by United. All tees shall be conical.
 - .6 Balancing dampers where noted to be butterfly type with Duro-Dyne heavy-duty hardware, damper blades of 1.2mm (18 ga.) perforated plate.
 - .7 Diameter Gauge (USSG)

Up to 10"	24
11" to 20"	22
21" to 40"	20
41" to 60"	18
61" and over	16

2.4 RELIEF AIR BACKDRAFT DAMPER

- .1 Provide Penn CBD-6 heavy duty counter-balanced backdraft damper where noted.
-

- .2 Counter-balanced weights to be field adjustable for fine tuning.
- .3 Units shall be capable of operating in both horizontal and vertical plane.
- .4 Blades to be aluminum roll formed blades that pivot in ball bearings.
- .5 Frame to be heavy duty galvanized steel.

2.5 DUCT ACCESS DOORS

- .1 Install airtight, 25mm (1") internal glassfiber insulated access doors in ductwork as noted and at all humidifier dispersion tubes, motorized dampers; at inlet and outlet of vaneaxial and axial fans; at inlet of heating coils; at fire dampers and locations noted on Drawings.
- .2 Access doors at fire dampers, fire/smoke dampers and smoke detectors shall be minimum 300mm (12") x 300mm (12") or larger to fully access and replace fusible link. Enlarge duct as required.

2.6 FAN SYSTEMS - GENERAL

- .1 Fan Connections
 - .1 Duro-Dyne Metal-Fab of neoprene coated fibreglass, airtight, water tight and flameproof, 75mm (3") wide with 75mm (3") galv. metal connections.
 - .2 Fan Bearings
 - .1 Fan bearings shall be selected to have minimum B10 life of 15,000 hours or minimum average life of 75,000 hours.
 - .2 All grease lubricated bearings that are not directly accessible shall be fitted with extended grease leads terminating at some convenient accessible location on the fan casing.
 - .3 Fan Vibration Isolators
 - .1 Spring vibration isolators designed and selected to operate at no greater than 2/3 solid deflection and be stable for lateral displacements. Spring mounts c/w levelling device and rubber sound pads. For loads less than 227 kg (500 lbs.) and deflection less than 31mm (1.2"), use Vibro Acoustics CM cast type mount. For loads and deflections greater than this, Vibro-Acoustics type FS open type mounts shall be used.
 - .2 Unless noted otherwise, mount floor mounted air handling units upon CM spring mounts to give 25mm (1") static deflection.
 - .3 Hang all suspended fans with SH-1 spring hangers to provide 25mm (1") static deflection.
 - .4 Fans to have prime coat finish of red oxide except dome exhausters. Wheels and shafts to be statically and dynamically balanced.
 - .5 Scheduled operating fan speeds and outlet velocities noted in Specification herein and/or in fan schedules shall be maximum acceptable.
 - .6 Guards
-

- .1 Protect V-belt drives by guards that encompass all sides of the drive. Any expanded mesh or ventilation openings in the guard are to be "finger proof" to meet OSHA requirements.
- .2 Mount guards to the fan by bolted clips. They shall be completely removable.
- .3 Each guard shall be c/w two 25mm diameter holes opposite both fan and motor shaft for purpose of allowing tachometer readings. Each hole will be covered with gravity-actuated swing cap.
- .4 Front face of drive guard shall be hinged and latched for convenient access to interior.
- .7 Refer to Fan Schedule for fan sizes, capacities, etc.

2.7 CENTRIFUGAL EXHAUST FAN, F-1 (PRE-PURCHASED)

- .1 The City has pre-purchased new centrifugal exhaust fan F-1 manufactured by Cincinnati Fan (Nederman Part No.86000037). The City shall supply fan to Contractor for installation.
 - .1 Fan is built according to the following Specifications:
 - .1 Backward inclined bladed fan is a Cincinnati model HDBI, Size 150, Class II, Arrangement 4 direct-drive.
 - .2 Backward inclined blades fabricated of heavy gauge high-strength steel.
 - .3 Turned, ground and polished shaft complete with a rust preventative coating applied prior to shipment.
 - .4 Heavy-duty, self-aligning, relubricatable, ball bearings in cast iron pillow blocks.
 - .1 Bearing base is heavy steel construction with internal supports for maximize rigidity.
 - .5 Fan housing complete with an inlet side support to eliminate vibration.
 - .6 Fan complete with inverter duty rated motor.
 - .7 Refer to Mechanical Fan Schedule MS-1 for capacity and performance.

2.8 TROLLEY C/W BALANCER & DAMPER

- .1 Provide a Nederman trolley designed to operate with Nederman Series 920 exhaust extraction rail.
 - .2 Trolley to be complete with Balancer and Ø6" (150 mm) hose connection.
 - .3 Trolley configuration shall be comprised of four running wheels, four guide wheels. All wheels to have sealed ball bearings and rollers made of polyurethane.
 - .4 Trolley to have a continuous temperature resistance of 300°F (150°C) and be resistant to all chemicals found in diesel and petrol exhaust.
 - .5 Nederman Trolley Part No. 20374380.
 - .6 Provide Nederman Damper Part No. 20373796.
-

2.9 HOSE

- .1 Provide a Nederman NR-B hose designed to operate with Series 920 exhaust extraction rail trolley.
- .2 Hose shall be capable of withstanding average stress under normal operation of extracting exhaust from spark ignition engines or diesel engines.
- .3 Hose shall meet the following specifications;
 - .1 Material: Polyester fabric with EPDM coating
 - .2 Helix material: Steel
 - .3 Helix cover: EPDM
 - .4 Colour: Black with blue helix
 - .5 Maximum temperature, intermittent: 347°F (175°C)
 - .6 Maximum temperature, continuous: 257°F (125°C)
 - .7 Minimum temperature: -40°F (-40°C)
 - .8 Bending radius (inside) max. 9" (225 mm)
- .4 Nederman Part No. 20823562.
- .5 City shall supply the Metal Support Band (pre-purchased) Nederman Part No. 20344593.

2.10 DUCT STATIC PRESSURE SENSOR

- .1 Provide pressure transducer to sense static pressure in main exhaust duct.
- .2 Nederman Part No. 86900083.

2.11 VARIABLE FREQUENCY DRIVE (VFD)

- .1 Description of System
 - .1 This specification provides requirements for the supply and installation of Variable Frequency Drives (VFD's) systems for fans as specified in other sections of this specification. The VFD system shall include the VFD module (complete with its filters), the input and output cables and the disconnect.. The VFD's shall be capable of variable or constant torque as required by the specifications and schedules. The selection of the VFD shall be made by the fan manufacturer to ensure that the optimum supply and installation of each VFD is achieved. The VFD shall include all alarms and functions as specified in this section and other related sections and schedules. The VFD and its peripheral devices, as required by specifications are to be located in a sprinkler proof enclosure to suit the environment in which it is located.
 - .2 References and Regulations
 - .1 NEMA ICS 3.1 - Safety standards for Construction and Guide for Selection, Installation and Operation of Adjustable Speed Drive Systems.
 - .2 UL 508C - Underwriter's Laboratory
 - .3 CAN/CSA-C22 No. 14 - Canadian Standards Association.
 - .4 CSA 22.2 No. 100-95.
 - .5 CSA 22.1 Canadian Electrical Code.
 - .6 EN61800-3.
 - .7 Other applicable Standards and Regulations.
-

- .8 C-UL marking to provide an approved listing for both United States and Canadian users. The Manufacturer will furnish the product as listed and classified by Underwriter's Laboratories as suitable for the purpose specified and indicated.
- .9 IEEE 519 - 1992: Conforming but not limited to the following values from the Standard for General Systems, non-hospital and airports.
 - .1 For the type of environment that is applicable.
 - .1 THD for Voltage 5% (based on fault levels indicated on electrical drawings or harmonic survey if applicable).
 - .2 SPEC NOTE: Discuss the need for harmonic measurement with the electrical department
 - .3 THD for Current as per IEEE 519-92
 - .4 Harmonic levels for each individual voltage and current harmonic to meet IEEE 519-92.
 - .5 Individual and total voltage and current distortion as per IEEE 519-92.
 - .6 Voltage notching as per IEEE 519-92. (Notch Area and Depth as per Table 10.2 for General System applications, notch depth 20%, notch area 22,800
 - .7 Levels shall be limited to the requirements set by IEEE 519-92 for General Systems.
- .3 Training
 - .1 Provide training for each type of VFD in addition to the site specific training supplied by Division 15 for the fan or pump with which the VFD has been supplied.
 - .2 Ensure that manuals and drawings are available for the training.
 - .3 The training shall include specific information relating to the application as specified in other sections of the specifications as well as general operation and maintenance of the VFD.
 - .1 Include procedures for the setting of parameters within the VFD for the particular application(s) specified as well as an explanation of the purpose of each parameter that is accessible to the maintenance personnel and the specific instructions required to alter the parameters.
 - .2 The instructions will include a written record of the final parameter settings after set-up and commissioning, for each VFD supplied as part of the project. General or generic values are not permitted. Record and turn over the values set in each VFD.
- .4 Harmonic Modelling
 - .1 During Bid, set up a harmonic model, using the fault levels indicated on the electrical plans/schematics. Use actual cable lengths and sizes to produce the model. Set up a harmonic model to simulate the following:
 - .1 Voltage distortion after installation of the VFD system.
 - .2 Operation of all new VFDs.

Using the model, the VFD manufacturer shall select, supply and install filtration to meet the requirements of this specification.

The harmonic simulation shall be carried out using proprietary harmonic modelling software. The VFD manufacturer shall furnish the VFD harmonic spectrum for each VFD type for use in the harmonic model.

The outcome of the harmonic modelling shall be submitted to the Contract Administrator as part of the submittals process for comment as

a bound report. The report shall contain the baseline measurement results, the input data (fault level, transformer ratings and impedances, cable sizes, lengths etc...).

- .5 Shop Drawings and Product Data
 - .1 Shop Drawings are to be submitted for each VFD. Shop Drawings shall include but not be limited to the following submissions:
 - .1 Catalogue and technical data.
 - .2 A "comply/non-comply" list of the shop drawing submissions, addressing each item of the specification indicating that it complies with the specification, or else stating the deviation.
 - .3 Outline dimensions, weights etc. including any special locating/installation instructions.
 - .4 Control Drawings and schematic diagrams including all connections to external equipment and devices. Include single line and impedance diagrams. Include internal circuit schematics and the layout of all electronic and electrical components.
 - .5 Line harmonic calculations, including filter calculations required to comply with the voltage and current distortion levels required by IEEE 519 (IEEE 519-92). Include the voltage distortion level at the electrical distribution equipment based upon actual cable sizes and lengths and fault levels indicated on the electrical drawings. If harmonic survey is required, base distortion levels on existing background levels. The intent is to reduce the harmonic content to a level that will not create damage to the City's equipment, and to reduce harmonic content at the point of common coupling.
 - .6 Instruction manuals for programming and installation.
 - .7 Include a list of all initial values of parameter settings. Optimize the parameter settings for this application.
 - .8 Manufacturer's installation instructions for the VFD, line and load reactors, control cabling, filters, VFD shielded cabling, motor etc.
 - .6 Maintenance Data
 - .1 Provide maintenance data as per Section 15010.
 - .2 Include as-built Shop Drawings with the O&M manuals.
 - .3 Provide all schematics, diagrams, and as-built Drawings including interconnections to other equipment.
 - .4 Provide programming manuals c/w the actual setting of all parameters. Provide all site-specific programming etc.
 - .7 Products
 - .1 The Variable Frequency Drive (VFD) system shall include, but not be limited to, the supply and installation of the following: pulse width modulated VFD, with IGBT inverter section, NEMA enclosure, filtering, wiring, grounding, line reactors, load reactors and/or dv/dt filter, relays, motor starters, protective devices, programming, software etc. required by this section and all other sections to make a complete working system.
 - .2 Voltage is to be as described in Division 16 specifications and schedules.
 - .3 VFD size is to be as per Division 15 schedules.
 - .4 The VFD system including but not limited to the enclosure, RFI filters, reactors, grounding etc. is to be the manufacturer's tested assembly.
-

- .5 The VFD shall meet the following conducted and radiated emissions levels as defined in EN61800-3 (2004):
- .1 First Environment Restricted Level of EN61800-3 (2004), through the use of enclosure design and integral EMI/RFI filters:
 - .1 Conducted emissions (Category C2): 79dBuV up to 0.5MHz, and 73dBuV above 0.5MHz.
 - .2 Radiated emissions: 40dBuV/m up to 230MHz, and 47dBuV/m above 230MHz.
All measurements for radiated emissions at 10m from VFD, (quasi peak).

It shall be the contractor (or third parties doing the installation) responsibility to install the VFD's according to the manufacturer's recommendations (cable type, cable routing etc...) in order to meet the EMC levels.

- .2 The manufacturer's installation and grounding instructions are to be included with each VFD.
 - .3 Output cables to motors for mechanical assemblies provided in other sections of this specification are to be shielded (Teck Drive RX) and are to be specifically manufactured for variable frequency drives. Installation is to be as specified by the manufacturer. Refer to Division 16 Specifications and Drawings.
 - .4 Provide instructions to the Division 16 contractor for termination of shielded cables (Teck Drive RX cables) from the output of the VFD to the motor and input feeder to the VFD from its point of supply.
 - .5 Provide grounding instructions to the Division 16 contractor. All equipment including, filters, reactors, variable frequency drive, motor, enclosure, control cabling are to be grounded according to manufacturer's requirements. Grounding instructions are to be included in installation manuals included with each drive. The VFD manufacturer or his representative is to examine grounding once the cabling has been installed and terminated to ensure that it meets the manufacturer's written instructions.
 - .6 The VFD manufacturer or his representative is to examine the installation of the VFD to ensure that the installation complies with current codes, regulations and the manufacturer's installation requirements. Provide a letter confirming this to the Contract Administrator.
 - .7 The VFD manufacturer is entirely responsible for the enclosure design and EMI performance and compliance with the emission levels defined in this specification. The enclosure is to meet the following minimum requirements:
 - .1 Enclosure to be fabricated from non-corroding metal (galvanized steel is acceptable)..
 - .2 Unpainted metal to metal contacts shall be used throughout the enclosure and shall be bonded to a common point using braided grounding straps. Secure covers at not more than 100mm spacing.
 - .3 Where gaskets are used, they shall be conductive.
-

- .4 Holes in the enclosure shall be minimized (21mm in width or covered with proprietary RFI proof louvres).
 - .5 Separate radiating 'dirty' side (upstream supply side of filter) from 'clean' side (load side of filter) of installation using metal covers.
 - .6 Enclosure to be fabricated from >0.75mm galvanized steel. Powder paint coat the outside surface.
 - .7 Terminate all Teck Drive RX cables inside VFD enclosure.
 - .8 Efficiency: >95% at full load, full speed at 4kHz carrier frequency.
 - .9 Noise: 82dBA at full load, full speed at 4kHz carrier frequency
- .8 System includes:
- .1 The VFD and its peripheral devices are to be fully enclosed in an approved enclosure to suit the environment in which it is located (e.g. weatherproof if located in wet environments).
 - .2 Enclosures are to be sprinkler proof even if the drive is located in a location without sprinklers. Sprinklers may be installed in the future.
 - .3 VFDs mounted in plenum spaces shall be plenum rated.
 - .4 Disconnecting means for the drive is to be located in the VFD enclosure and interlocked to the door of the enclosure. An input circuit breaker is an acceptable disconnecting device.
 - .5 Thermal overloads suitable for use with the motor.
 - .6 Thermistor input for motor over-temperature shutdowns.
 - .7 Control power transformer rated for drive power. The power supply shall be fused.
 - .8 Diode or fully gated bridge on the input.
 - .9 DC Bus inductor on all VFD's with ratings of 7.5HP (5.5KW) or greater.
 - .10 Switching logic power supply operating from the DC bus.
 - .11 Microprocessor based inverter logic isolated from power circuits.
 - .12 Latest generation IGBT inverter section.
 - .13 Phase to phase and phase to ground MOV protection.
 - .14 Auxiliary contacts - 2 form C contacts for each of the following signals:
 - .1 Drive Alarm
 - .2 At Speed
 - .3 Control power on
 - .4 Drive fault
 - .5 Drive run
 - .6 Reversing
 - .7 Jogging
 - .8 Peripheral Interface to enable attaching common options.
 - .9 Others as provided with the VFD or as described in other Sections of the Specifications.
 - .15 Line reactors are to be included but not be limited to the following, as required to meet IEEE 519-92. The intent is to reduce the following harmonic indices to an acceptable level as per IEEE 519-92 at all points in the electrical distribution system, in the building at the time of installation of the VFD. The recommended harmonic indices are, but not limited to:
 - .1 Depth of notches, total notch area and distortion of bus voltage by commutation notches (low voltage notches)
-

- .2 To comply with IEEE 519-92 for General Systems.
 - .3 For the type of environment that is applicable.
 - .4 THD for Voltage 5% (based on fault levels indicated on electrical drawings and harmonic survey if applicable).
 - .5 THD for Current as per IEEE 519-92
 - .6 Harmonic levels for each individual voltage and current harmonic to meet IEEE 519-92.
 - .7 Individual and total voltage and current distortion as per IEEE 519-92.
 - .8 Voltage notching as per IEEE 519-92 (Notch Area and Depth as per Table 10.2 for general systems).
 - .16 Output line reactors and or dv/dt filters if motor is not inverter duty rated (NEMA MG1 pt 31).
 - .17 Filters shall be constructed and installed so that they will not supply any existing or future loads.
 - .18 Common mode choke sized to the amperage of the drive.
 - .19 Copper ground bus.
 - .20 Operator interface to the drive shall be provided by a module with integral display.
 - .1 The display shall be a 2 line, 16 character alphanumeric, backlit LCD that is used to show drive operating conditions, fault indications and programming information. The display shall be customer programmable to show faults, operating temperatures and pressures, etc and programming information. The module shall provide programming information plus an operation keypad with Start, Stop, Speed Reference (analog pot or digital keys), direction control / indication and Jog. The module shall be connected to the drive via a cable and installed in the main door of the VFD enclosure. The units shall be capable of allowing the operator to change set points, temperature and pressures, lead/lag pumps etc. as required by other sections of this specification and the manufacturer of the pumps and fans.
 - .2 The keypad is to be accessible without opening the door of the VFD enclosure.
 - .9 Operation
 - .1 The drive is programmable or self-adjusting for operation under the following conditions.
 - .1 Controlled shut down with no component failure in the event of an output phase to phase or phase to ground short circuit and annunciation of the fault condition.
 - .2 Selectable Sensorless Vector or V/Hz mode.
 - .3 The VFD shall include, but not be limited to the following protective parameters that are to be displayed at the LCD interface: overcurrent, overvoltage, inverter fault, undervoltage, overtemperature, motor overtemperature, phase loss - input and output etc.
 - .4 As described in other Sections of this Specification.
 - .2 Selectable for variable or constant torque loads. Selection of variable torque provides 115% of rated VT current for up to one minute. Selection of constant torque provides 150% of rated CT current for up to one minute.
 - .3 Multiple programmable stop modes including - Ramp, Coast, DC-Brake, Ramp-to-Hold and S-curve.
 - .4 Multiple acceleration and deceleration rates from 0 to 3600 seconds.
-

- .5 Adjustable output frequency up to 400Hz.
 - .6 Inputs and outputs
 - .1 Two analogue Inputs shall consist of single ended inputs, isolated inputs, and bipolar inputs that can be configured as 0-10 VDC or 0-20 ma. The analogue inputs shall be able to be programmed to process control, trim pre-set speeds and frequency control, etc. Provide three single ended inputs and other types as described and as required by other sections of this specification.
 - .1 Refer to other sections of this specification for additional requirements.
 - .2 Digital Inputs and Outputs shall consist of the following:
 - .1 Six digital inputs, positive or negative logic; nominal voltage to be 24VDC.
 - .2 A minimum of two programmable Form C relay outputs.
 - .3 One digital outputs open collector 50mv/48V
 - .4 Refer to other sections of this specification for additional requirements.
 - .3 Analogue Outputs
 - .1 0(4) to 20ma: RL 50 ohm max. 10 bit accuracy.
 - .2 Refer to other sections of this specification for additional requirements.
 - .7 Adjustable minimum and maximum motor speeds set in consultation with the motor and equipment manufacturers to prevent damage to the motor. The motor selection shall be coordinated with the selection of the VFD by the fan or pump supplier.
 - .8 Communications to include but not be limited to RS232/422/485 and industry standard communication protocols e.g. DeviceNet, Modbus RTU, LonWorks, Backnet, Johnson Controls N2L. The use of 3rd party boards is acceptable to connect LonWorks for example to the VFD, providing the supplier of the VFD has tested and certified the use of the 3rd party product with the VFD, partnering is preferable.
 - .1 Other protocols may be requested. Refer to other sections of this specification for additional requirements.
 - .9 Manufacturer
 - .1 ABB (Nederman Part No. 86900083)
 - .10 Installation
 - .1 The drive is to be installed to CSA 22.1, current codes, standards, and other sections of this specification. The drive is to be installed to manufacturer's recommendations.
 - .2 Install the variable frequency drive, cabling, ancillary equipment etc. to the manufacturer's instructions.
 - .3 The manufacturer of the VFD is to coordinate and review the installation of the VFD with Division 16.
 - .4 The drive is to be wired to achieve the following functions:
 - .1 Remote start and stop (isolated input at 24 VDC or 120 VAC)
 - .2 Speed to be adjusted by a remote analogue input i.e. 4-20ma.
 - .3 Wire and connect control wiring to pre-set speed control equipment. Set and adjust as pre-set speeds as indicated in other sections of this
-

- specification. Configure trimming of pre-set speeds by analogue inputs to the VFD from remote equipment as indicated in other sections.
- .4 Those as required by other sections of the specification.
 - .5 Install the VFD drive securely on a flat wall surface, as close to the motor as possible, within the distance allowed by the maximum conductor length specified by the drive manufacturer.
 - .6 Install the VFD as far as practical from telecommunications equipment, control equipment and wiring. Maintain a minimum distance of three meters from the VFD and its feeders from telecommunication and control cables. VFD input and output cables are to cross communication and control cables at 90 degrees.
 - .7 Division 16 to provide Teck Drive RX cable from the VFD to the motor. Division 16 is to provide Teck Drive RX to the input of the VFD from the circuit breaker feeding the VFD. The Teck Drive RX cable is specifically manufactured for use with variable frequency drives. Connectors for the Drive RX cables are to be specifically designed for use with this type of cable, as per the cable manufacturer's instructions. The cable is to be bonded as per the VFD manufacturer's instructions. Division 15 is to coordinate with Division 16.
 - .1 Grounding is to be as per the manufacturer of the VFD's instructions and CSA requirements for safety and to reduce RFI and EMI.
 - .2 All control conductors are to be shielded of a type specified by the manufacturer. The shields are to be grounded as per the manufacturer's instructions. All control wiring shall be in conduit. All conduits used for control wiring shall include a separate insulated ground conductor, #12 AWG minimum.
 - .3 The conduit for the control conductors shall not be installed within 600mm of the power conductors for the VFD. The shields of the cables shall be grounded according to the manufacturer's instructions for:
 - .1 Analogue signals
 - .2 Digital signals
 - .4 The control cables shall be terminated in terminals (supplied with the VFD enclosure). Shielded cables shall be grounded according to the VFD manufacturer's instructions.
 - .5 The VFD shall be programmed, commissioned, set-up and tested by the manufacturer's representative. The drive shall be set-up to optimize the operation with the specific equipment that the drive has been specified with, in other Sections of this Specification.
 - .6 Examine the Division 15 Shop Drawings for the motor that is supplied by the equipment supplier. The motor must be suitable for the intended use and shall be labelled as such, as required by CSA C22.2 No. 100-95. Ensure that the labels are on the motor before connecting. If the motor is not suitable for use with the VFD and/or is not labelled, notify the Division 15 contractor immediately.
 - .7 Division 16 to provide a three pole disconnect switch with an auxiliary contact at the motor. The auxiliary contact is to open prior to the main switch blades. Division 16 is to provide a 2/C #14 Teck cable from the VFD to the disconnect switch. Connect the switch in the VFD to stop the output to the motor prior to the opening of the disconnect switch.
-

Part 3 Execution

3.1 DUCT OPENINGS

- .1 Locate only openings in walls, floors, partitions, beams, etc. required for ducts, equipment, etc. General Contractor to form all openings for same, except as noted below.

3.2 DUCT AND EQUIPMENT SUPPORTS, HANGERS AND INSERTS

- .1 Design, Installation
 - .1 Supports to secure ducts and equipment, prevent vibration and provide for expansion and contraction. Design supports of strength and rigidity in a manner which will not stress the building construction. Use inserts for suspending hangers. Do not use vertical expansion shields without Contract Administrator's approval.
 - .2 Concrete Inserts
 - .1 Do not weaken concrete or penetrate waterproofing membrane. Use reinforcing rods through inserts for pipe sizes over 50mm (2"), or equivalent weight. Where concrete slab is finished ceiling, inserts to be flush with surface.
- .3 Protect insulation at contact with hangers and support with approved metal shields.

3.3 CO-ORDINATION WITH H.V.A.C. BALANCE AND TESTING AGENCY

- .1 Refer to Section 15990 H.V.A.C. Balance and Testing. Co-ordinate Work with Section 15990.
- .2 As a part of this Contract, Section 15800 shall make any changes in pulleys and belts, and add manual dampers for correct balance as recommended by 15990, at no additional cost to City.
- .3 Section 15800 responsible for initial alignment and tension of all fan pulleys and belts, of equipment supplied by Section 15800.

3.4 HIGH PRESSURE DUCTWORK

- .1 Use for all high pressure exhaust ductWork to exhaust rail system units.
 - .2 Drawings indicate general layout of ductWork. Additional offsets or changes in direction to be made at no extra cost to City.
 - .3 On round and spiral ductWork, outside sleeve surface and duct to be brushed with sealing compound before assembly. Place sheet metal screws on 200mm (8") centres, with three screws, each side of joint. After assembly, brush both joint and screws with sealing compound. Seal all duct seams, and joints between ducts, fillings, etc. with Duro-Dyne S-2 duct sealer and Duro-Dyne FT-2 fiberglass duct tape. Prior to installation ductWork to be clean, dry and free of grease. Apply duct sealer with a stiff brush or trowel. Wrap wet seam or joint with duct tape and apply further coat of duct sealer. Duct sealer and glassfiber to extend 25mm (1") on each side of joint or seam.
-

- .4 90 deg. elbows to be 5-piece mitred construction. 200mm(8") diam. 90 deg. elbows or less can be solid 1-piece molded type. Use conical connections throughout installation.
- .5 Install flat oval ducts as per manufacturer's published Bulletin F.O. #6. Brace with United truss couplings or angle flanges on four foot centres. Use companion angle flanges with maximum width (major axis dimension) exceeds 660mm (26"). This bracing to limit wall deflection from static pressure to maximum of 100mm (.41") at 1.2 kPa (5") static pressure. Provide matched fittings. Install and seal as per requirements for round and spiral ductWork.

3.5 TESTING OF HIGH PRESSURE DUCTWORK

- .1 Outlets from test section to be sealed off. Apply required test pressure. Use special testing fan. Determine leakage with manometer and oriface plate in connection between fan and test section. Test apparatus and method to be approved by Contract Administrator.
- .2 Test ductWork at 305mm (12") W.G. Leakage not to exceed 1% of average operating air flow in section.
- .3 Notify Contract Administrator one week in advance of when such tests are to take place.

3.6 DUCT ACCESS DOORS

- .1 Locate properly for inspection and servicing. Doors and frame to be rigid, close-fitting, with rubber gaskets, galvanized hinges with brass pins and at least two galvanized cam locks. Rivet frame and hardware to ducts.
- .2 Where impossible to swing access doors, install removable door with four cam locks.

3.7 PITOT TUBE TEST OPENING ENCLOSURES

- .1 Locate in ductWork at supply fan discharges, on intake of exhaust and return air fans, in hot and cold ducts coming off plenums, in major duct branches and everywhere pitot tube opening is required for proper balancing of air conditioning, ventilation and exhaust systems. Do not place closer than 1524mm (6 ft/) to elbows. Space every 150mm (6") across air stream at each location. Refer to Drawings for additional opening requirements.

3.8 FAN SYSTEMS - GENERAL

- .1 Use flexible connections at inlets and outlets where ductWork and plenums connect to fans and air-handling equipment.
 - .2 Fan Vibration Isolation
 - .1 Install as per Isolation manufacturer's published data.
 - .3 All equipment shall be installed in strict accordance with manufacturer's published data.
 - .4 Protection of Fan Equipment Before Installation
 - .1 Grease shafts, sheaves, etc. to prevent corrosion. Fan bearings to be greased or oiled at time of building takeover.
 - .5 Centrifugal fans located outdoors to have drain holes in casing.
-

- .6 Co-ordinate installation of smoke detectors with Division 16 - Electrical.

3.9 CENTRIFUGAL AIRFOIL FANS

- .1 Submit performance curves. Information covering fan performance to be available in catalogue form.
- .2 Base
 - .1 Mount fan and drive on integral slide-rail base, isolated from supporting pad by spring channel frame.
- .3 Fan Bearings
 - .1 Fan bearings to have 20,000 hours minimum average life.

3.10 TESTING OF DUCTWORK

- .1 Visually and audibly check for air leaks that can be heard or felt under normal operating conditions. Repair all leaks in ductWork.
- .2
 - .1 Tests shall be performed by Section 15990. Refer to Section 15990.
 - .2 Section 15800 shall provide all necessary temporary connections, blank-offs, tees, required for testing. Section 15990 shall provide all test fans, equipment and labour required for testing.
 - .3 Section 15800 shall clean all ducts before testing.
 - .4 During installation of ductWork include separate leakage air tests of each complete air riser; each completed horizontal distribution system, and after ductWork is installed and central station apparatus is erected, leakage testing of pressure side of whole system. Include testing of flexible runouts (where applicable).
 - .5 After preliminary tests, repair all leaks.
 - .6 Be responsible for any damage resulting from failure of items under test.
 - .7 Section 15800 shall repair all leaks in duct system.
 - .8 Section 15990 shall retest ductWork after leaks have been repaired.
 - .9 Section 15180, 15800 and 15990 shall co-ordinate Work to ensure that all ductWork is tested:
 - .1 Before ducts are insulated.
 - .2 Before ducts are concealed.

3.11 AIR FLOW MEASURING STATIONS

- .1 Units in acoustically lined ducts are to be sized to suit clear dimensions of acoustic insulation and not of size to suit sheet metal duct. Where units are located in acoustic lined ducting, install heavy gauge metal channel and fasten to metal duct to receive unit frame. Space between channel and duct to be filled with flexible insulation.
 - .2 On plenums and ducts with external insulation, Section 15900 to provide channel mounting frame of same thickness as insulation. Pack channel frame with loose fibreglass insulation.
-

END OF SECTION

Part 1 General

1.1 GENERAL

- .1 All Drawings and all sections of the Specifications shall apply to and form an integral part of this section.
- .2 Wherever words "shall be capable of" appear in Specifications, interpret as meaning that; where feature or performance referred to is being applied, that feature or performance shall be provided.

1.2 WORK INCLUDED

- .1 Labour, Material, plant, tools, equipment and services necessary and reasonably incidental to completion of control/instrumentation systems as noted herein and/or on the Drawings.
- .2 Control equipment to be product of Johnson Controls.
- .3 New fan unit F-1 will be supplied by City and Installed by Section 15800. Section 15900 shall supply, install, and wire all control components required by the new fan unit to achieve sequence of operation specified in this Section.
- .4 Division 15900 shall coordinate with Division 15800 prior to and during fan start up and commissioning.
- .5 Division 15900 shall provide an individual Johnson Metasys DDC unit controller for new fan unit.
- .6 This building has an existing Johnson Metasys B.M.S. (Building Management System). Division 15900 shall provide new control wiring for new equipment and run back to B.M.S. system as required. The B.M.S. shall be expanded as required to monitor and control the new exhaust fan system.

1.3 RELATED WORK SPECIFIED ELSEWHERE

- .1 Section 15010 Mechanical General Provisions
- .2 Section 15800 Air Distribution
- .3 Section 15990 Testing, Adjusting and Balancing
- .4 Section 16010 Electrical

1.4 WORK BY OTHER SECTIONS

- .1 Section 15800 to distribute and mount all air measuring stations, etc. in their respective locations, as supervised by Section 15900.
- .2 Division 16 - Electrical to supply and install all conduit, wire and connections from the distribution panels to line side of magnetic starters and thermal overload switches, and from load side of starters and switches to motors.

1.5 ELECTRICAL WIRING PERFORMED BY SECTION 15900

- .1 Supply and installation of all conduit, wire, electric relays, connections and other devices required for control circuit wiring for systems as specified in Section 15900, whether line or low voltage, shall be responsibility of Section 15900, except as noted above.
- .2 Section 15900 shall either use own electricians, retain and pay for services of successful Division 16, or use an electrical sub-trade acceptable to Contract Administrator to supply and install all conduit and wiring for systems as specified in this Section.
- .3 Factory trained servicemen in employ of manufacturer, shall make final wiring connections on all components, mount and electrically connect all controls.
- .4 Electrical wiring shall be installed in conformance with CSA, ULC, Manitoba Building Code, National Building Code of Canada 1990 and standards set in Division 16 of this Specification.
- .5 Ensure that adequate conduit is installed during initial phases of construction, to accommodate total systems requirements.
- .6 Wire all safety controls in series with both 'Hand' and 'Auto' starter positions to ensure that systems are properly protected.
- .7 Section 15900 shall provide all other conduit and wiring required for Section 15900 systems operation, including tie-ins from Section 15900 supplied relays to motor starting circuits.
- .8 As a minimum, provide separate, dedicated conduit system for each of following.
Conduit to be minimum 19mm EMT.
 - .1 B.M.S. transmission wiring.
 - .2 All other wiring connected to an electronic control system including sensor and control wiring associated with DDC panels, DGP's, etc., which are connected to the B.M.S. system or are capable of being connected at some future date.
 - .3 Sensor and control wiring for stand-alone pneumatic/electric control systems. Conduit identification labels shall state "B.M.S." for 1., and 2., 3. above, and "CONTROL WIRING" for .4 above.
- .9 If approved by system manufacturer, cable up to 30 Volts may be installed in extra-low voltage communication cable tray.

Part 2 Products

2.1 IDENTIFICATION OF EQUIPMENT - GENERAL

- .1 Use engraved black and white laminated plastic, 25mm x 62mm (1") x (2-1/2"), at all panels, etc., supplied so as to clearly indicate service of particular device. Manual switches, unless they come with standard nameplates, switches, etc., installed on local panels to be similarly labelled. All controllers, relays, etc. mounted inside local panels may have tape labels.
- .2 Provide lamacoid identification plates fastened with rivets or self-tapping screws at all equipment supplied by Section 15900 so as to clearly indicate service of particular device. All manual switches, unless they come with standard nameplates, shall be similarly labelled.
- .3 Equipment installed on surfaces of local panels shall be similarly labelled. Equipment mounted inside local panels, must have permanent plate labels with self-tapping screws. Tape labels are not acceptable.
- .4 Identification plates, by Section 15900, to be white background with minimum 5mm high black letters, unless specified otherwise.
- .5 Information on lamacoid identification plates to be consistent with 'as-built' control Drawings.
- .6 Prior to lamacoid fabrication, submit copies of control Drawings and complete list of proposed wording for each lamacoid, for approval by Contract Administrator and City. Include copy of approved lamacoid list in each Maintenance/Operating Manual.

2.2 INSTRUMENT CABINETS

- .1 Provide at each system or groups of systems, cabinet type metal control panel with all instruments mounted inside locking cover. All panels shall have same key. Temperature indication and control point adjustments and gauges labelled as to function with lamacoid nametags fixed to panel face with self-tapping screws. All electrical equipment mounted in cabinet to be pre-wired to labelled terminal strips.

2.3 IDENTIFICATION OF DATA GATHERING & D.D.C.PANELS

- .1 Provide lamacoid nameplates to identify following:
 - .1 Data Gathering Panel Title.
 - .2 Supply feeder panelboard number, circuit number, and panelboard location.
- .2 Fasten nameplates with rivets or self-tapping screws to exterior of Data Gathering Panel door.
- .3 Refer to subsection "Identification of Equipment - General", and comply with all requirements related to lamacoid nameplates.

- .4 For each panel or terminal cabinet, indicate designation, system, load and area served. Provide directories to identify all termination points. For each termination point, identify equipment connected, equipment location and termination wire colour code or identification code number. Insert copy of directory in clear plastic pouch attached inside panel or terminal cabinet door, and insert copy into each Maintenance/Operating Manual. All wires or cable shall be colour coded and/or identified with identification code using wire markers. Information on data cards or directories shall be either typewritten or neatly printed with permanent ink.

2.4 FIELD DATA PANEL

- .1 Factory wire and test. Encoding and decoding equipment shall be of printed circuit board construction.
- .2 Design panel such that in case of localized trouble, panel can be isolated from system for testing and repairs without effecting normal operation of total system.
- .3 Locations of field data panels shall be approved by Contract Administrator prior to installation.
- .4 Panels shall be capable of handling multiple systems with ability to have at least two different and not necessarily sequential systems assigned to one panel.
- .5 Each panel to operate set points in accordance with points list.
- .6 On power failure at panel, each panel shall run through power failure routine so that no data will be lost either remotely or centrally. After power failure, each affected start/stop fan or motor to remain OFF until either operator at Central Console manually turns motor ON; or until automatic power fail restart programme starts. Power failure at one building shall not interrupt operation of remainder of system.
- .7 Panels shall be individually fused for input power and separately fused for all control voltages.
- .8 Panels shall be capable of electrically supervising all wiring required for security system points. Wiring shall be supervised for short circuits, open circuits and ground fault conditions, and shall transmit to CPU type of condition and location of circuit affected.

2.5 INTERCONNECTION WITH BUILDING MANAGEMENT SYSTEM (B.M.S.)

- .1 City has installed B.M.S.
- .2 Control systems specified herein shall be adaptable to interconnections with this system i.e. following should be included in this contract.
 - .1 On all alarm points provide extra set of contacts for connection to B.M.S.
 - .2 On all mixed air dampers provide necessary electro/ pneumatic devices required to allow closed/auto operation of dampers from B.M.S.

- .3 All input and output points which are connected to D.D.C. panels shall be interconnected to B.M.S. Provide all D.D.C. panel and B.M.S. software revisions and/or modifications to complete the B.M.S. connection.
- .4 System programming shall include following provisions:
 - .1 Run times and number of starts for all equipment where on-off status is monitored, including all pumps and fans.
 - .2 Analog alarm limits on all analog sensing points (high and low where applicable).
 - .3 Sliding limits where setpoint moves in controlled manner.
 - .4 Current set point provided as keyname.
 - .5 Keyname listing as indicated on detail sheets.
- .5 Update all B.M.S. Drawings and documentation.

2.6 IDENTIFICATION OF EQUIPMENT CONTROLLED BY B.M.S.

- .1 Provide adhesive back tags for all pieces of equipment controlled by the B.M.S.
- .2 Tags shall be white background with red letters, 100mm wide x 70mm high, with rounded corners, and shall read as follows:

"WARNING
- THIS EQUIPMENT IS UNDER CENTRAL CONTROL AND MAY START
OR
STOP WITHOUT WARNING"
- Leave starters in 'AUTO' position.
- Phone B.M.S. Office to inform monitoring room if equipment
is being shutdown.
- Ensure disconnect is locked off prior to Working on
equipment."
- .3 Tags shall be of 3M Material, similar to that used for renewal tags on automobile licence plates, as available from Aristo-Print Limited, Winnipeg.
- .4 Submit one sample tag for approval prior to installation.

2.7 FAN SYSTEM CONTROLS - GENERAL

- .1 Following control sequences shall apply to all supply fan systems whether specifically noted in sequence of operation or not.
- .2 On variable volume systems with exhaust duct static pressure control of exhaust fan volume, static pressure sensor shall be located at the end of the longest duct run. Co-ordinate with Section 15990 during system set-up. Should relocation of static pressure sensor be required to provide proper system control, Section 15900 shall relocate sensor as directed by Contract Administrator. Provide second independent static pressure sensor located in fan discharge to function as high limit and override control of exhaust fan volume device to prevent overpressurization of system.

2.8 EXHAUST SEQUENCE OF OPERATION

- .1 Variable Air Volume Welding Exhaust Fan F-1
 - .1 General:
 - .1 METASYS compatible DDC Control.
 - .2 The system shall operate on a scheduled and manual basis as determined by the operator.
 - .2 System Off:
 - .1 The exhaust fan shall be off during unoccupied hours.
 - .2 The exhaust air damper shall be closed.
 - .3 System Start:
 - .1 METASYS system will be programmed by City to run fan system (and VFD) from 7:00a.m. - 2:30 p.m. (Monday - Friday).
 - .2 At all other times (other than those specified in item .1 above) the METASYS system shall run fan system (and VFD) upon detecting push of remotely located manual start/stop button.
 - .4 System Run:
 - .1 Occupied Mode:
 - .1 VFD shall adjust fan speed to maintain duct static pressure set-point (adj.) in response to changes in duct pressure caused by the opening/closing of exhaust dampers in trolleys.
 - .2 System Stop:
 - .1 The fan system (and VFD) shall stop upon detecting a second pushing of manual start/stop button.
 - .5 Safeties and Alarms:
 - .1 Remote located start/stop button shall be complete with an on/off status light, which shall be wired back to METASYS for monitoring.
 - .2 METASYS system shall monitor VFD status.
 - .6 Failure Modes:
 - .1 Fan Failure: If the fan fails to operate, fan shall shut down and an alarm shall annunciate.
 - .2 Fan: Upon restoration of power, the supply fan shall start after an adjustable delay to provide a staggered start of all building loads.

Part 3 Execution

3.1 GENERAL

- .1 Control components and interconnecting tubing systems to be installed by trained control mechanics, regularly employed by Section 15900.

3.2 EXISTING BUILDING SYSTEM

- .1 During Bid period visit jobsite to review section of existing systems relating to the new installation.
- .2 Co-ordinate new installation with existing system. Make revisions to existing systems as noted on Drawings and/or in Specifications.

3.3 OPERATING INSTRUCTIONS AND AS-BUILT INFORMATION

- .1 Provide operating instructions as specified elsewhere. Include schematic Drawings of all control systems including control sequence write-up.
- .2 Provide three hard cover copies of complete information pertaining to temperature control\instrumentation system for City's permanent record. This to include following:
 - .1 As-built schematic control diagrams with complete control sequence write-up.
 - .2 Operator's manual including maintenance instructions.
 - .3 Engineering data and data product sheets.
 - .4 Parts list of all components including repair instructions.
 - .5 Suggested spare parts list.
- .3 Provide in DDC operator's manual, details of all functions, operator interaction with the system, complete with examples. Manual shall be written by professional technical writers. Provide operator's pocket guides for quick reference on day-to-day routine operations.

3.4 SERVICE AND WARRANTY

- .1 Upon completion of installation, all equipment shall be adjusted as required to place system in complete operating condition subject to Contract Administrator's approval. Make all adjustments in collaboration with field engineer responsible for balancing air system.
- .2 If within one year from date of completion as interpreted by Contract Administrator, any of equipment herein described is proven to be defective in Workmanship or Materials, it shall be replaced or repaired free of charge to City.
- .3 After installation completion, provide any service incidental to proper performance of control system under guarantees outlined above for guarantee period. Normal maintenance of system or adjustment of components is not to be considered part of guarantee.

End Of Section

Part 1 General

1.1 GENERAL

- .1 All Drawings and all sections of the Specifications shall apply to and form an integral part of this section.
- .2 Testing, Adjusting and Balancing (TAB) Agency shall be an experienced, independent contractor specializing in the testing, adjusting and balancing of HVAC systems.
- .3 TAB Agency shall be a member of the Associated Air Balance Council (AABC) and Work shall carry standard AABC Certificate of Guarantee.
- .4 Include extended service for 90 days after completion of final balancing Work, during which time Contract Administrator at his discretion may request re-check or re-setting of any systems and/or equipment listed in test report

1.2 SCOPE OF WORK

- .1 Provide complete testing, adjustment and final balancing of new exhaust air system.
- .2 Provide complete ductwork leakage testing as specified.

1.3 RELATED WORK SPECIFIED ELSEWHERE

- .1 Section 15010 Mechanical General Provisions
- .2 Section 15800 Air Distribution
- .3 Section 15900 Controls/Instrumentation

Part 2 Products

2.1 BALANCING REPORTS

- .1 Provide two copies of detailed draft balancing report to Contract Administrator for review after completion of all adjustments.
- .2 Final balancing report shall incorporate all changes resulting from Contract Administrator's comments and any adjustments undertaken since the draft report was issued.
- .3 Provide four copies of final balancing report.
- .4 Provide sufficient number of copies of final balancing report to Mechanical Subcontractor for inclusion in Operating & Maintenance Manuals.

2.2 DUCT LEAKAGE TEST REPORTS

- .1 Provide two copies of duct leakage test reports to Contract Administrator including test data for all preliminary and final tests.

Part 3 Execution

3.1 GENERAL

- .1 All instruments used shall be accurately calibrated and maintained in good Working order. If requested, tests shall be conducted in the presence of Contract Administrator and/or his representative.
- .2 Schedule all Work to comply with completion date.
- .3 Work shall not begin until system has been completed and in full Working order. Division 15 shall put ventilating system and equipment into full operation, as operation would demand, and shall continue operation of same during each Working day of testing, adjusting and balancing.

3.2 AIR BALANCING

- .1 Coordinate with Sections 15800 to ensure installation of all manual adjusting dampers, blast gates and pitot tube enclosures are as indicated, as specified and as required to allow proper adjustment of air systems.
- .2 Sections 15800 to provide initial alignment and tension of all fan pulleys and belts supplied by them.
- .3 Testing Procedure:
 - .1 Test, adjust and record all fan speeds, motor amperes.
 - .2 Make pitot tube traverse to main supply and obtain cfm at fan.
 - .3 Test and record static pressure for each system at fan suction and discharge.
 - .4 Adjust all exhaust air ducts to proper design cfm.
 - .5 Test and adjust each damper to within 5% of design requirements. Balance as per manufacturer's recommendations.
 - .6 Fan operating conditions tested shall confirm air delivery within 5% of manufacturer's fan curves.
 - .7 Systems shall be balanced so that fans operate at lowest possible static pressure.
 - .8 Variable speed drives shall not be used to reduce fan capacity to achieve balance condition. Balance on fan drive only with VSD at 100% capacity.
 - .9 Prepare single line diagrams of duct systems indicating terminal outlets identified by number. List on data sheets all such outlets denoted by the same numbers, including the outlet sizes, 'K' factor, location, cubic feet per minute and jet velocity. Provide this data for all supply, return and exhaust air systems.
- .4 As part of Work of this Contract, Sections 15800 shall make any changes in the pulleys and belts, and any additional manual dampers and blast gates for correct balance as

recommended by Section 15990, at no additional cost to City. Section 15990 shall provide final alignment and tension adjustment of fan pulleys and belts.

- .5 Air balancer shall approach balancing of new exhaust system similar to balancing a VAV (variable air volume) system. Air balancer to ensure exhaust extraction hose located furthest from fan F-1 (Bay 18) achieves specified flow rate when extraction hose located closest to fan F-1 (Tool Bay) is in operation.
 - .1 Air balancer shall make adjustments to the exhaust system by positioning blast gates to achieve system balance.
 - .1 All extraction hoses shall be capable of performing at exhaust rates specified on Drawings at all times when they are in use.
 - .2 Air balancer shall set up the following scenario during system balancing:
 - .1 Bay 18 extraction Hose Damper - Open
Bay 17 extraction Hose Damper - Closed
Bay 16 extraction Hose Damper - Open
Bay 15 extraction Hose Damper - Open
Tool Bay extraction Hose Damper - Open
Bay 14 extraction Hose Damper - Closed
Bay 13 extraction Hose Damper - Open
 - .2 Adjust balancing damper/blast gates to achieve specified airflows under scenario outlined in .1 above.

3.3 SYSTEM CHECK

- .1 Provide spot checks of systems if called upon by Contract Administrator. If capacities, fan speeds, ratings, etc. do not agree with submitted balance report, rebalance system or systems in question, until satisfactory results are received.

3.4 LEAK TESTING OF AIR DUCTS

- .1 General:
 - .1 Tests shall be performed by Section 15990.
 - .2 Section 15800 shall provide all necessary temporary connections, blank-offs, tees, required for testing. Section 15990 shall provide all test fans, equipment and labour required for testing.
 - .3 Section 15800 shall clean all ducts before testing.
 - .4 During installation of ductwork include separate leakage air tests of each complete air riser; each completed horizontal distribution system, and after ductwork is installed and central station apparatus is erected, leakage testing of flexible runouts (where applicable).
 - .5 Perform preliminary tests and repair all leaks before notifying Contract Administrator of final tests.
 - .6 Maintain log book of all tests showing dates, personnel, observers' initials.
 - .7 Be responsible for any damage resulting from failure of items under test.
 - .8 Section 15800 shall repair all leaks in duct systems.

- .9 Section 15990 shall retest ductwork after leaks have been repaired.
- .10 Coordinate the Work as required with Sections 15180, 15800, Mechanical Contractor and General Contractor to ensure that all ductwork is tested:
 - .1 Before ducts are insulated.
 - .2 Before ducts are concealed.
- .11 Issue report to Contract Administrator after witnessing final tests.
- .2 Leakage Testing of Other Systems: (including all variable air volume systems)
 - .1 Make tests prior to insulation of system being tested using suitable test equipment, including 'U' tube, orifice, tubing and cocks, arrange to indicate amount of air leakage.
 - .2 Make leakage test with pressure maintained for minimum of 5 minutes at level of 150% of average operating pressure of duct section under test, obtained by operation of air supply fan, or if fan cannot be operated, by use of test blower. Inspect and check joints for leakage, record and submit results.
 - .3 Allowable leakage at test pressure: 5% of design maximum flow rate of duct section under test.

END OF SECTION

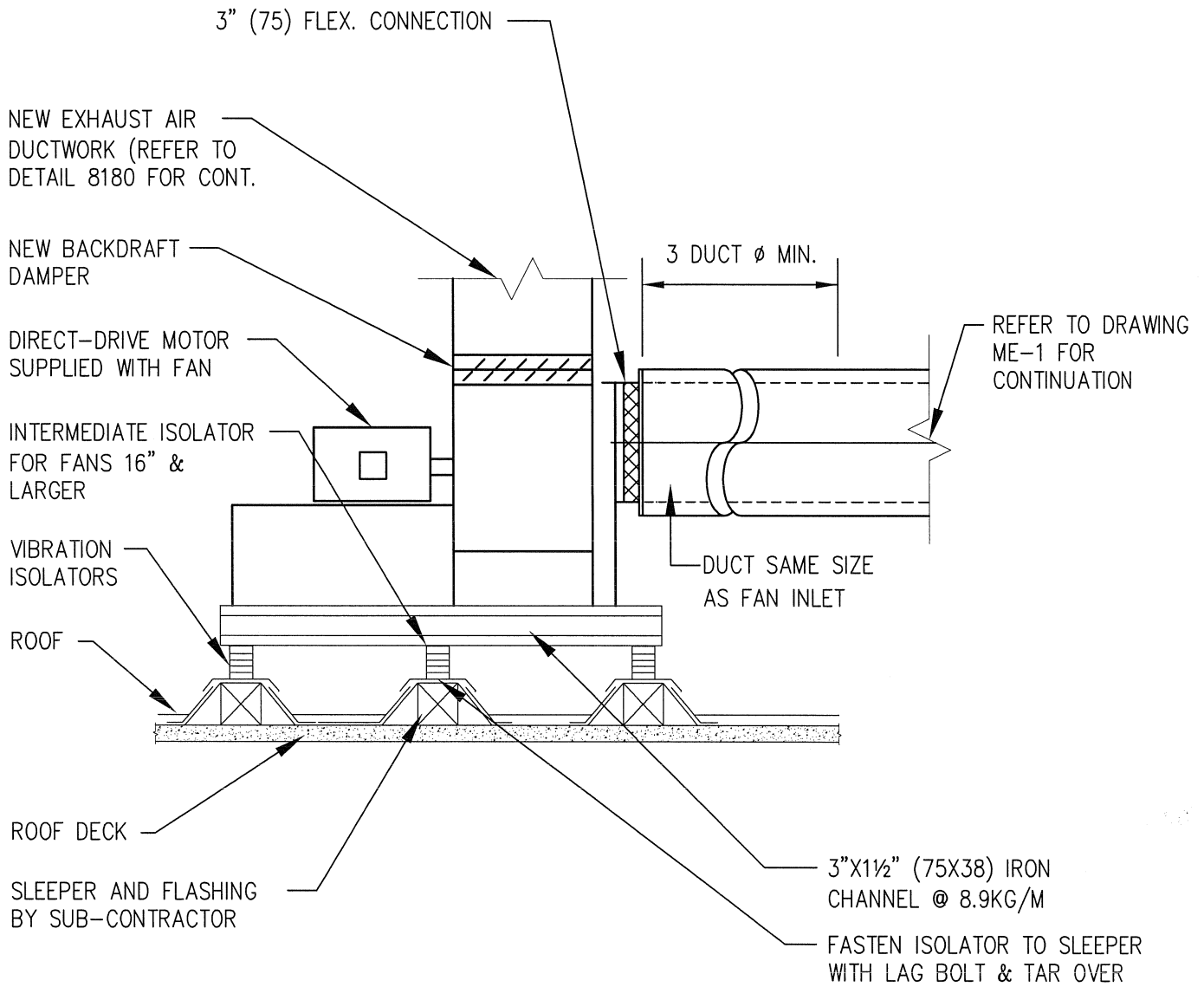

SMS ENGINEERING

SMS Engineering Ltd. Consulting Engineers
 770 Bradford Street Winnipeg MB Canada R3H 0N3
 Telephone 204.775.0291 Fax 204.772.2153
 sms@smseng.com

SPECIFICATION DETAIL

CENTRIFUGAL ROOF EXHAUST FAN

Drawn By SMS	Approved By SMS	Reference 8120
File No. 07-198-01	Date NOV. 2007	Detail Sheet MD-1

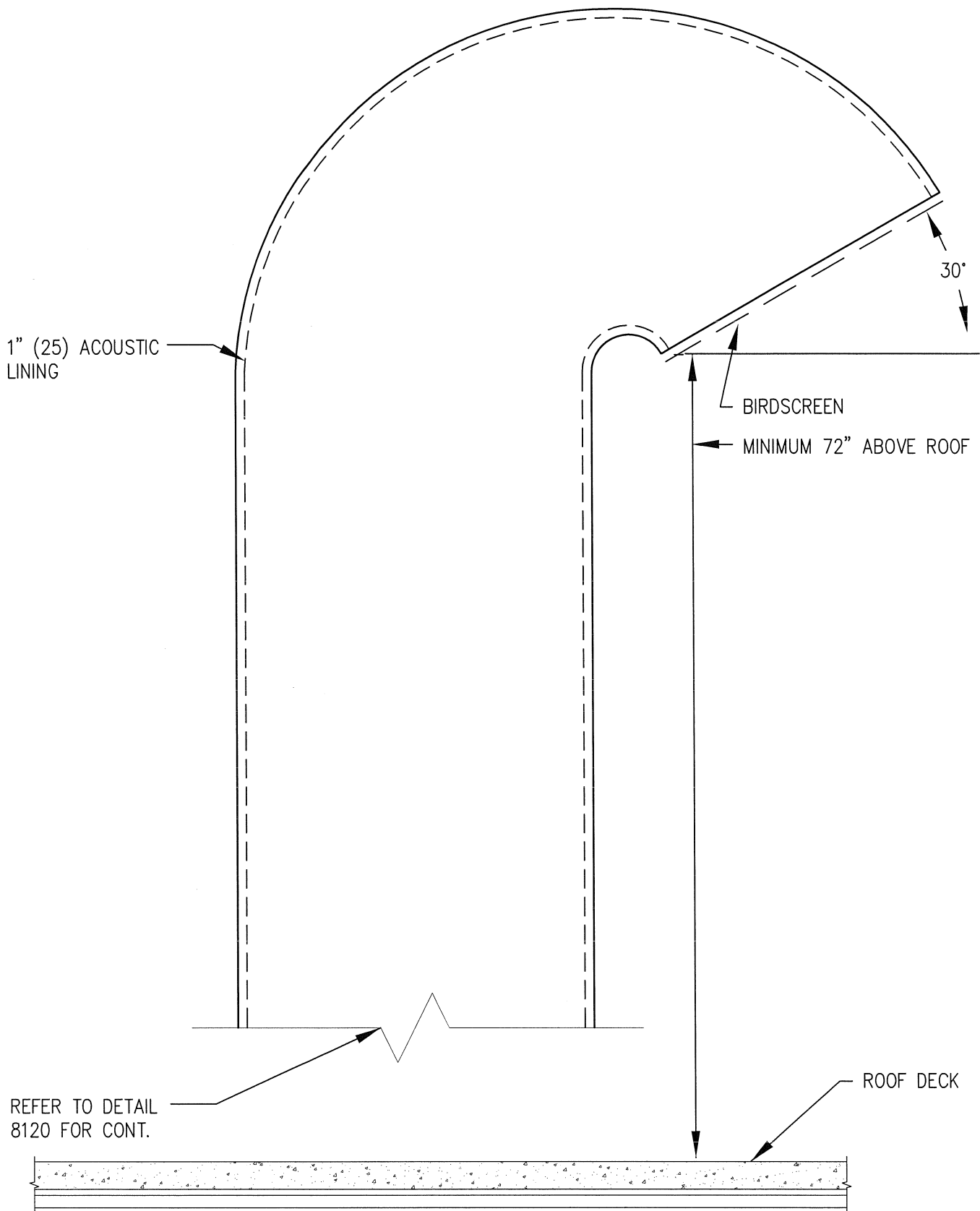

SMS ENGINEERING

SMS Engineering Ltd. Consulting Engineers
 770 Bradford Street Winnipeg MB Canada R3H 0N3
 Telephone 204.775.0291 Fax 204.772.2153
 sms@smseng.com

SPECIFICATION DETAIL

EXHAUST GOOSENECK

Drawn By SMS	Approved By SMS	Reference 8180
File No. 07-198-01	Date NOV. 2007	Detail Sheet MD-2

Part 1 General

1.1 GENERAL

- .1 This Section covers items common to Sections of Division 16. This section supplements requirements of Division 1.
- .2 All Drawings and all sections of the Specifications shall apply to and form an integral part of this section.

1.2 CODES AND STANDARDS

- .1 Do complete installation in accordance with CSA C22.1 except where specified otherwise.
- .2 Do overhead and underground systems in accordance with CSA C22.3No.1 except where specified otherwise.
- .3 Abbreviations for electrical terms: to CSA Z85.
- .4 The electrical installation shall comply with the requirements of the Electrical Supply Authority, the latest edition of the Canadian Electrical Code, with all Provincial and Municipal Laws, Rules and Ordinances, and to the satisfaction of those persons having jurisdiction over same.
- .5 Notify the Contract Administrator of any discrepancies or conflicts with any regulation in accordance with B4. Failing such notification, meet all such requirements without change to the contract price.
- .6 In no instance shall the standard established by these Specifications and Drawings be reduced by any of the codes, rules or ordinances.

1.3 CARE, OPERATION AND START-UP

- .1 Upon completion of the project, demonstrate the operation of all equipment in the presence of the City, or his representative, and the Contract Administrator. Obtain signed certification from the City that such equipment was shown to be fully operational and that all necessary operating instructions have been provided.
- .2 Arrange and pay for services of manufacturer's factory service engineer to supervise start-up of installation, check, adjust, balance, calibrate, test and commission components as specified in subsequent sections.
- .3 Provide these services for such period, and for as many visits as necessary to put equipment in operation, and ensure that operating personnel are conversant with all aspects of its care and operation.
- .4 Carefully examine all plans and Specifications pertaining to this Contract and become familiar with all details. Visit the site and determine all factors affecting this section of the Work and include all costs for same in bid.

1.4 VOLTAGE RATINGS

- .1 Operating voltages: to CAN3-C235.
- .2 Motors, electric heating, control and distribution devices and equipment to operate satisfactorily at 60 Hz within normal operating limits established by above standard. Equipment to operate in extreme operating conditions established in above standard without damage to equipment.

1.5 PERMITS, FEES AND INSPECTION

- .1 Submit to Electrical Inspection Department and Supply Authority necessary number of Drawings and Specifications for examination and approval prior to commencement of Work.
- .2 Pay all associated fees for inspection of the Work by authorities having jurisdiction.
- .3 Notify Contract Administrator of changes required by Electrical Inspection Department prior to making changes.
- .4 Furnish Certificates of Acceptance from authorities having jurisdiction on completion of Work to Contract Administrator. Copies to be included in Maintenance Manuals.

1.6 MATERIALS AND EQUIPMENT

- .1 Provide Materials and equipment in accordance with Div. 16.
- .2 Equipment and Material to be CSA certified or certified by an equivalent recognized certifying agency to meet Canadian Standards. Where there is no alternative to supplying equipment which is certified, obtain special approval from local Electrical Inspection Department or authority having jurisdiction.
- .3 Factory assemble control panels and component assemblies.
- .4 Submit for Contract Administrator's approval, a duplicate list of makes and types of all equipment and Materials for this project, prior to placing of orders for same. This shall be done within fourteen (14) days of the award of the project contract to the General Contractor in order to avoid delays in delivery and completion.
- .5 Any Material or equipment ordered or installed without the Contract Administrator's prior approval shall, if so directed by the Contract Administrator, be removed and replaced with approved Material or equipment without a change in the contract price.

1.7 RESPONSIBILITY

- .1 Be responsible for any damage caused the Citys, or their Contractors due to improperly carrying out this Work.
- .2 Install all components of this Work promptly and where applicable, in advance of concrete pouring, or similar construction. Provide and set in the proper sequence of construction, all sleeves, hangers, inserts, etc. and arrange for all necessary openings, where required to accommodate the electrical installation.

- .3 Work shall be arranged in co-operation with other divisions of this Specification in such a manner that it doesn't interfere with the progress of the project. In areas where ducts or pipes must be installed along with conduit or cable, co-operate with other divisions so that the finished job will represent the most efficient use of the space.
- .4 In no case proceed with any Work in uncertainty. Obtain, from the Contract Administrator, any clarification necessary and thoroughly understand all portions of the Work to be performed.

1.8 ELECTRIC MOTORS, EQUIPMENT AND CONTROLS

- .1 Supplier and installer responsibility is indicated on electrical Drawings, or in this Specification and related mechanical responsibility is indicated in Mechanical Equipment Schedule on mechanical Drawings.
- .2 Control wiring and conduit is specified in Division 16 except for conduit, wiring and connections below 50V which are related to temperature control systems specified in Division 15 and/or shown on mechanical Drawings.

1.9 FINISHES

- .1 Clean and touch up surfaces of shop-painted equipment scratched or marred during shipment or installation, to match original paint.
- .2 Clean and prime exposed non-galvanized hangers, racks, and fastenings to prevent rusting.

1.10 WORKMANSHIP AND MATERIALS

- .1 The installation shall consist of Material and equipment specified unless as provided herein. Electrical equipment provided under this contract shall be built in accordance with EEMAC standards and shall be C.S.A. certified (or certified by an equivalent recognized certifying agency to meet Canadian Standards) and/or locally approved. All equipment supplied under this contract shall be new and the best of its respective kind and of uniform pattern throughout.
- .2 Any Material or equipment ordered or installed without the Contract Administrator's prior approval shall, if so directed by the Contract Administrator, be removed and replaced with approved Material or equipment without a change to the contract.
- .3 Replace inferior Work if so ordered by Contract Administrator without a change to the contract.
- .4 Retain same foreman or superintendent on the job until completed, unless otherwise directed by the Contract Administrator.
- .5 All tradesmen shall carry all tools on their person at all times. Any tool not in use shall be under lock and key in an area authorized by the building supervisor.

1.11 CLEANLINESS AND CLEANING

- .1 This division shall maintain a clean tidy job site. All boxes, crates, and construction debris due to this portion of the Work shall be neatly piled outside the construction area and shall be removed at least weekly during the construction period. All construction areas shall be kept clear of debris.
- .2 Before the project will be accepted by the City, all lighting fixtures, lamps, lens, panelboards, switches, receptacles, cover plates, and other electrical equipment shall be clean and free of dust, plaster, paint, etc. Any equipment which is scratched or damaged shall be refinished or replaced if so designated by the Contract Administrator.

1.12 MODIFICATIONS

- .1 Locations of all outlets, etc. are subject to modification by the Contract Administrator, who reserves the right to move these up to 3000 mm from the position shown, without change to the contract price, provided notice is given before the related Work has commenced.

1.13 REQUEST FOR EQUAL

- .1 Applications for approval of equal, or alternate Materials, or methods, as substitutions for those specified or shown, shall be submitted to the Contract Administrator in accordance with B6. If an "Equal" has been granted, the choice between the Materials or methods specified and those approved as equal shall be optional with this Contractor.

1.14 ENGINEERING OBSERVATIONS

- .1 The term "Contract Administrator" in all electrical sections of Specification shall mean:
SMS Engineering Ltd.
770 Bradford Street
Winnipeg, Manitoba
R3H ON3
- .2 Contractor's Work will be observed periodically by City, and/or Contract Administrator or their representatives, solely for purpose of determining general quality of Work, and not for any other purpose. Guidance will be offered to Contractor in interpretation of plans and Specifications to assist him to carry out Work. Observation and directives given to Contractor does not relieve Contractor and his agents, servants and employees of their responsibility to erect and install Work in all its parts in a safe and Workmanlike manner, and in accordance with plans and Specifications, nor impose upon City, and/or Contract Administrator or their representatives, any responsibility to supervise or oversee erection or installation of any Work.
- .3 Contractor shall notify Contract Administrator for a final distribution inspection prior to energizing distribution system. All distribution equipment shall be left with covers removed to allow a thorough inspection.

1.15 GUARANTEE

- .1 Guarantee the satisfactory operation of all Work and equipment supplied and installed as a part of this section of the Specifications.

- .2 Replace forthwith, at no additional Material or labour cost, any part which may fail, or prove defective within a period of twelve (12) calendar months after the final acceptance of the complete installation, provided that such failure is not due to improper usage, or ordinary wear and tear.
- .3 No certificate given, payment made, partial or entire use of the equipment by the City or his representative shall be construed as acceptance of defective Workmanship or Materials.
- .4 This general guarantee shall not act as a waiver of any specified guarantee or special equipment guarantees covering a greater length of time.

1.16 IDENTIFICATION OF EQUIPMENT

- .1 Identify electrical equipment with nameplates and labels as follows and as indicated in other Specification sections.
- .2 Nameplates:
 - .1 Lamacoid 3mm thick plastic engraving sheet, shall be white with black letters or as directed, mechanically attached with self tapping screws. Nameplates for equipment fed from emergency power or from emergency UPS power (increase nameplate size as required to suit wording) shall be white with red letters.

NAMEPLATE SIZES

Size 1	10 x 50mm	1 line	3mm high letters
Size 2	12 x 70mm	1 lines	5mm high letters
Size 3	12 x 70mm	2 lines	3mm high letters
Size 4	20 x 90mm	1 line	8mm high letters
Size 5	20 x 90mm	2 lines	5mm high letters
Size 6	25 x 100mm	1 line	12mm high letters
Size 7	25 x 100mm	2 lines	6mm high letters

- .3 Labels:
 - .1 Embossed plastic labels with 6mm high letters unless specified otherwise.
- .4 Fabrication details of all nameplates labels and wording on nameplates and labels to be approved by Contract Administrator prior to manufacture.
- .5 Allow an average of twenty-five (25) letters per nameplate and label.
- .6 Room names and numbers used shall be actual room names and numbers that will be used on the project. Division 16 to co-ordinate and confirm with trades involved.
- .7 Identification to be English.
- .8 Co-ordinate names of equipment and systems with Division 15 to ensure that identical names are used.
- .9 Nameplates for terminal cabinets and junction boxes to indicate system and/or voltage characteristics.

- .10 Nameplates for disconnects, starters and contactors: Indicate equipment being controlled and voltage.
- .11 Nameplates for terminal cabinets and pull boxes: Indicate system and voltage.
- .12 Nameplates for transformers: Indicate capacity, primary and secondary voltages.
- .13 Nameplates for control devices: indicate equipment controlled.
- .14 Adjacent to each breaker in CDP type panelboards, provide and mount lamacoid nameplates identifying the respective load and location.
- .15 To match existing where applicable.

1.17 WIRING IDENTIFICATION

- .1 Identify wiring with permanent indelible identifying markings on both ends of phase conductors of feeders (coloured plastic tapes) and branch circuit wiring (numbered wire markers). Conductor marker identification shall correspond with panel or terminal board directory information.
- .2 Maintain phase sequence and colour coding throughout.
- .3 Colour Code: To CSA C22.1.
- .4 Use colour coded wires in communication cables, matched throughout system. Colour coding used shall be documented by individual systems in Maintenance Manuals.
- .5 Insulated grounding conductors shall have a green finish and shall be used only as a grounding conductor.

1.18 CONDUIT, OUTLET BOXES AND CABLE IDENTIFICATION

- .1 Colour code conduits, boxes and metallic sheathed cable.
- .2 Code with plastic tape or paint at points where conduit or cable enters wall, ceiling, or floor, and at 15m intervals.
- .3 Colours: 25mm wide prime colour and 20mm wide auxiliary colour.

	<u>Prime</u>	<u>Auxiliary</u>
Up to 250V (normal power)	yellow	
Up to 600V (normal power)	yellow	green
Up to 250V (emergency power)	yellow & red	
Up to 600V (emergency power)	yellow & red	green
Control	blue	
- .4 Other conduit systems as directed on site; all conduit systems shall be identified.
- .5 Color outlet box covers to color designated and show circuit numbers in black felt marker on inside of covers.

1.19 WIRING TERMINATIONS

- .1 Lugs, terminals, screws used for termination of wiring to be suitable for either copper or aluminum conductors.

1.20 MANUFACTURERS AND CSA CERTIFICATION LABELS

- .1 Visible and legible after equipment is installed.

1.21 WARNING SIGNS

- .1 As specified and to meet requirements of Electrical Inspection Department and Contract Administrator.
- .2 Decal signs, minimum size 175 x 250mm.

1.22 LOAD BALANCE

- .1 Measure phase current to panelboards with normal loads (lighting) operating at time of acceptance. Adjust branch circuit connections as required to obtain best balance of current between phases and record changes.
- .2 Measure phase voltage at loads and adjust transformer taps to within 2% of rated voltage of equipment.
- .3 Submit, at completion of Work, report listing phase and neutral currents on panelboards, dry-core transformers and motor control centres, operating under normal load. State hour and date on which each load was measured, and voltage at time of test. Provide copy of report in all maintenance manuals.

1.23 CONDUIT AND CABLE INSTALLATION

- .1 Install conduit and sleeves prior to pouring of concrete. Sleeves through concrete: Schedule 40 steel pipe, sized for free passage of conduit, and protruding 50mm each side.
- .2 If plastic sleeves are used in fire rated walls or floors, remove before conduit installation.
- .3 Install cables, conduit and fittings to be embedded or plastered over, neatly and close to building structure so furring can be kept to minimum.
- .4 Arrange for holes through exterior wall and roof to be flashed and made weatherproof.

1.24 FIELD QUALITY CONTROL

- .1 Conduct and pay for following tests:
 - .1 Power distribution system including phasing, voltage, grounding and load balancing.
 - .2 Circuits originating from branch distribution panels.
 - .3 Motors, heaters, and associated control equipment including sequenced operation of systems where applicable.
 - .4 Any other electrical systems.

- .2 Furnish manufacturer's certificate or letter confirming that entire installation as it pertains to each system has been installed to manufacturer's instructions.
- .3 All circuits shall be tested to ensure that the circuit numbers are correct and that the proper neutral conductors have been provided and installed.
- .4 Insulation resistance testing:
 - .1 Megger circuits, feeders and equipment up to 350V with a 500V instrument.
 - .2 Megger 350V - 600V circuits, feeders and equipment with a 1000V instrument.
 - .3 Check resistance to ground before energizing.
- .5 Advise Contract Administrator of dates and times for all testing with sufficient advance notice to allow Contract Administrator to make arrangements to attend.
- .6 Provide instruments, meters, equipment and personnel required to conduct tests during and at conclusion of project.
- .7 Submit test results for Contract Administrator's review.
- .8 Insert test results and supplier's certifications in Maintenance Manuals.

1.25 DRAWINGS

- .1 Carefully examine all Drawings and Specifications relating to all Work, and all electrical Work indicated thereon shall be considered as a part of the Work by this section unless indicated otherwise. Prior to the date of the last addendum report at once to the Contract Administrator, any defect, discrepancy, omission or interference affecting the Work of this section, or the guarantee of same.
- .2 Install all equipment as shown or as specified and in accordance with manufacturer's approved shop Drawings.
- .3 The Drawings accompanying these Specifications are intended to show the general arrangement and extent of the Work to be carried out, but the exact location and arrangement of all parts shall be determined as the Work progresses. The location of equipment, outlets, etc., as given on the Drawings are approximately correct, but it shall be understood that they are subject to such modifications as may be found necessary or desirable at the time of installation to meet any structural or Contract Administrator's requirements. Such changes shall be implemented as directed by the Contract Administrator, without additional charge.
- .4 Electrical Drawings do not show all structural and other details. Contract Administrator's and structural conditions shall govern, and this Section shall make without charge, changes or additions to accommodate these conditions.
- .5 Where Drawings indicate the general location and route to be followed by conduit, cable, etc., these locations must be governed by job conditions. Where the required conduit, cable, an boxes are not shown on Drawings or only shown diagrammatically, they shall be installed to conserve maximum head room and interfere as little as possible with free use of space through which they pass. Maximum clearance above floor shall be

maintained under all suspended conduit and equipment, unless otherwise shown on the Drawings, or approved by the Contract Administrator.

- .6 Submit a complete set of Drawings for the proposed installation to the Inspection Department having jurisdiction and receive written approval before installation or fabrication of any equipment. No extra compensation will be allowed for any changes or rearrangement of any electrical apparatus or Materials necessary due to failure to receive this approval.
- .7 Provide the Electric Utility with three copies of a Drawing showing the main distribution and the proposed method of metering for approval prior to the manufacture of equipment.

1.26 SHOP DRAWINGS, PRODUCT DATA AND SAMPLES

- .1 Submit shop Drawings, produce detailed data and samples in accordance with previous sections, as specified herein, and to Contract Administrator's satisfaction.
- .2 Indicate details of construction, dimensions, capacities, weights and electrical performance characteristics of equipment or Material.
- .3 Where applicable, include actual wiring, single line and schematic diagrams. Include all technical data and full details of each component.
- .4 Include wiring Drawings or diagrams showing interconnection with Work of other sections.
- .5 Shop Drawings of all equipment must be submitted to the Contract Administrator for review in sufficient time to enable him to retain them for at least ten (10) Working days.
- .6 One print and one reproducible sepia of each shop Drawing shall be submitted.
- .7 Cross out or eradicate all non-related items.
- .8 Bind each system separately. One common binder from one supplier will not be acceptable.
- .9 Shop Drawing submission shall include a photocopy of all applicable Specification sections showing a complete compliance/ non-compliance listing. Refer to spec. detail sheet "Shop Drawing Compliance List Sample" for example.
- .10 Division 16 shall check all shop Drawings and make necessary changes, or cause the supplier to make necessary changes, prior to submission to the Contract Administrator. Shop Drawings will be reviewed by the Contract Administrator and if re-submission is required, Division 16 shall ensure that the supplier's Drawings have been changed to comply before returning them to the Contract Administrator for review again.
- .11 Review of the shop Drawings by the Contract Administrator shall not relieve the Contractor from responsibility for errors and omissions therein.
- .12 Each Drawing submission to bear the following signed stamp, and shall include name of project, equipment supplier, and clause number equipment is specified under.

CONTRACTORS CERTIFICATION

This Drawing has been reviewed by
(firm name)

All dimensions have been checked and found compatible with the contract Drawings and all capacities, quantities, sizes, and other data contained in the contract documents have been listed by the supplier on this Drawing and have been checked by the undersigned and found correct.

Date Per:

- .13 Clearly show division of responsibility. No item, equipment or description of Work shall be indicated to be supplied or Work to be done "By Others" or "By Purchaser". Any item, equipment or description of Work shown on shop Drawings shall form part of contract, unless specifically noted to the contrary.
- .14 Provide field dimensions required by electrical suppliers and sub-subcontractors. In cases where fabrication is required prior to field dimensions being available, check all related Drawings and obtain clarification from Contract Administrator if necessary.
- .15 Incomplete submissions will be returned for updating and re-submittal without Contract Administrator's review.

1.27 OPERATION AND MAINTENANCE DATA

- .1 Provide operation and maintenance data for incorporation into operation and maintenance manuals specified.
- .2 Include in operations and maintenance data:
 - .1 Details of design elements, construction features, component function and maintenance requirements, to permit effective start-up, operation, maintenance, repair, modification, extension, and expansion of any portion or feature of the electrical installation.
 - .2 Technical data, product data, supplemented by bulletins, component illustrations, exploded views, technical descriptions of items, and parts lists. Advertising or sales literature alone is not acceptable.
 - .3 Wiring and schematic diagrams and performance curves.
 - .4 Names and addresses of local suppliers.
 - .5 Copy of reviewed shop Drawings.
- .3 Provide five (5) complete, hard-backed, D-ring loose leaf Maintenance Manuals. These shall consist of typewritten or printed instructions for operating and maintaining all systems and equipment provided under this section of the Specification. Manuals shall also contain shop Drawings, wiring diagrams, test results and manufacturer's brochures on all equipment, together with typed index tab sheets.
- .4 As Work progresses, record on one (1) set of Drawings, installed conduit layout as well as any approved changes and deviations from the original contract and/or Working Drawings, including outlets, equipment and panel locations. At completion of Work,

submit to the Contract Administrator, at the contractor's costs, reproducible mylar Record Drawings. The contract shall not be considered complete and no final payment shall be made until these Drawings are accepted by the Contract Administrator. (Provide separate Drawings for each system in order not to "crowd" Drawings.)

- .5 Reproducible sepias of Record Drawings are to be mylar (diaz coated plastic film).

1.28 TEMPORARY LIGHTING AND POWER

- .1 All temporary and construction lighting and power Work and costs for same are not included as part of the scope of the Work of this section. Refer to such clauses in other sections of the Specification.

1.29 TESTING

- .1 Test all circuits and wires for continuity, insulation resistance and high impedance grounds. Those circuits which test non-continuous, with an insulation resistance less than 2 Megohms or with high impedance grounds shall be replaced.
- .2 All empty conduits shall be left with an insulated #14 AWG fish wire.
- .3 Keep a record of all final tests, bind, and turn over typewritten results to the Contract Administrator as a part of the maintenance manual. All final test values measured, date of each measurement, company name and signature of person making each measurement shall be neatly recorded. After all tests have been successfully completed, each test report shall contain a summary which clearly states that all results were satisfactory.
- .4 Upon completion of the Work and adjustments of all equipment, all systems shall be tested in the presence of the Contract Administrator to demonstrate that all equipment furnished and installed or connected as a part of this section of the contract shall function electrically in the required manner as determined by the Contract Administrator.
- .5 All circuits shall be tested to ensure that the circuit numbers are correct and that the proper neutral conductors have been provided and installed.
- .6 Voltage tests shall be conducted and transformer taps adjusted or other corrective measures carried out as directed by the Contract Administrator. Refer also to 4.1 Care, Operation and Start-Up.
- .7
 - .1 Carry out on-site testing and commissioning of all high voltage and low voltage switchgear including:
 - .1 Visual inspection
 - .2 Operational tests
 - .3 Meggar tests
 - .4 Contact resistance tests
 - .5 Phasing checks
 - .6 Metering
 - .7 Relay operation

- .8 Fluid levels
- .9 Hi-pot tests
- .2 Submit a report that includes test results, observations, summary, etc. Test report to clearly state that all results are acceptable.

1.30 CUTTING AND PATCHING

- .1 Cutting, patching and repairs to existing surfaces required as a result of the removal and/or relocation of existing equipment and piping, and/or installation of new equipment and piping in existing building(s) to be included by Div. 16 - Electrical in tender price. Division 16 - Electrical to employ and pay appropriate sub-trade whose Work is involved, for carrying out Work described above.
- .2 Perform all cutting and patching required for installing electrical systems.
- .3 Division 16 shall retain services of General Sub-trades to carry out actual Work involved in cutting wall openings, floor openings and the like, and in patching up after installation has been completed.
- .4 Division 16 shall mark all openings required for conduits, cables, ducts, and the like.
- .5 Cutting to be 'neat' sizes. Patch all edges such as cover plates, etc. Hide cut edges.
- .6 If, in the opinion of Contract Administrator, cutting of holes has been improperly performed (i.e. too large for conduits or cables) Division 16 - Electrical to do all patching as per original Specifications and all costs will be borne by him.

1.31 FIREPROOFING

- .1 Where cables or conduits pass through floors, block or concrete walls and fire rated walls, seal openings with 3 M Brand 7900 Series Fire Barrier System or equivalent, to maintain fire rating.
- .2 Fireproofing of electrical cables, conduits, trays, etc. passing through fire barriers shall conform to local codes and inspection authorities.

1.32 ACCESS DOORS

- .1 Provide and install access doors where electrical equipment requiring access is built-in. Access doors to be 2.5mm (12 ga.) steel, approximately 300mm x 300mm (12" x 12") minimum or as approved, finished prime coat only, with concealed hinges, anchor straps, plaster lock and without screws, all equal to Milcor manufacturer. All locks to be flush type, screwdriver operated. Where it is necessary for persons to enter through door, doors to be at least 600mm x 600mm.
- .2 In applied tile or exposed glazed or unglazed structural tile, access doors shall take the tile and be sized and located to suit tile patterns. In masonry walls access doors to be sized and located to suit masonry unit sizes. In removable acoustic tile ceilings, no access doors are required.
- .3 Access doors located in fire rated ceilings or walls shall be approved fire rated doors and frames.

- .4 Co-ordinate access door types, locations, etc. with Contract Administrator.

1.33 SECURITY FASTENERS AND HARDWARE

- .1 Refer to other sections of the Specifications for Security Fasteners. Division 16 to install security fasteners required for Division 16 Work.
- .2 This shall also include security tamperproof screws that are exposed such as in light fixtures, coverplates, system devices, outlet covers, etc.
- .3 Refer to other sections of the Specifications for security hardware.

1.34 PROTECTION

- .1 Protect exposed live equipment during construction for personnel safety.
- .2 Shield and mark live parts "LIVE 120 VOLTS", or with an appropriate voltage in English.
- .3 Arrange for installation of temporary doors for rooms containing electrical distribution equipment. Keep these doors locked except when under direct supervision of electrician.

1.35 SCHEDULING OF WORK

- .1 Existing buildings will remain in use during construction. Arrange Work so that interruption of services is kept to a minimum. Obtain permission from City prior to cutting into electrical services. Where deemed necessary by Contract Administrator, temporary electrical shall be installed and/or Work shall be carried out at night and on weekends.
- .2 Contractor to maintain continuous and adequate all existing electrical systems and other services during entire time of this contract. Provide temporary conduit, wire, equipment, etc. where necessary to meet this requirement.

1.36 EXAMINATION OF DOCUMENTS AND SITE

- .1 Carefully examine all plans and Specifications pertaining to this contract and become familiar with all details. Visit the site and determine all factors affecting this section of the Work; include all costs for same in tender.

1.37 DEMOLITION OF EXISTING ELECTRICAL

- .1 Remove all unnecessary existing electrical equipment, wiring, fixtures, in those portions of the existing building which are being remodelled or demolished. All devices/fixtures, etc. are not necessarily shown on the plans. The City shall select from the Materials and/or equipment remaining that which he wishes to retain, and the remainder shall be removed from the site. Any electrical equipment in remodelled sections or in structures removed or altered, adjacent to new Work, necessary for the operation of existing building, shall be relocated as necessary. All existing equipment re-used shall be made good and guaranteed. Power interruptions to be kept to a minimum and shall be at a time suitable to the building occupant. Refer to Contract Administrator's plans for demolition areas/phasing.

- .2 Drawings do not show all electrical requiring removal to accommodate renovations such as receptacles, switches, lights, starters, motors, nurse call systems, components, heaters, etc. Division 16 shall visit site, refer to electrical Drawings and include all costs for demolition.
- .3 Refer to Specification Section 16195 - Work in Existing Building.

END OF SECTION

Part 1 General

1.1 RELATED WORK SPECIFIED ELSEWHERE

- .1 Section 16010 Electrical General Requirements

1.2 LOCATION OF CONDUIT

- .1 Drawings do not indicate all conduit runs. Those indicated are in diagrammatic form only.
- .2 Produce layout sketches of conduit runs through mechanical and electrical service areas in order to pre-avoid any conflict with other construction elements and to determine the most efficient route to run conduit.

Part 2 Products

2.1 CONDUITS

- .1 Rigid galvanized steel threaded conduit.
- .2 Electrical metallic tubing (EMT): with couplings. Minimum size shall be 19mm.
- .3 Flexible metal conduit and liquid-tight flexible metal conduit.
- .4 Flexible PVC conduit.

2.2 CONDUIT FASTENINGS

- .1 One hole steel straps to secure surface conduits 50 mm and smaller. Two hole steel straps for conduits larger than 50 mm.
- .2 Beam clamps to secure conduits to exposed steel Work.
- .3 U channel type supports for two or more conduits at 1500 mm oc. (Surface mounted or suspended).
- .4 Six mm dia. galv. threaded rods to support suspended channels.

2.3 CONDUIT FITTINGS

- .1 Fittings for raceways: to CSA C22.2 No. 18.
- .2 Fittings: manufactured for use with conduit specified. Coating: same as conduit.
- .3 Factory "ells" where 90 deg. bends are required for 25 mm and larger conduits.
- .4 Steel set screw connectors and couplings. Insulated throat liners on connectors.

- .5 Raintight connectors and fittings c/w O-rings for use on weatherproof or sprinklerproof enclosures. Raintight couplings to be used for surface conduit installations exposed to moisture or sprinkler heads.

2.4 EXPANSION FITTINGS FOR RIGID CONDUIT

- .1 Weatherproof expansion fittings with internal bonding assembly suitable for 100 or 200 mm linear expansion.
- .2 Watertight expansion fittings with integral bonding jumper suitable for linear expansion and 19 mm deflection in all directions.
- .3 Weatherproof expansion fittings for linear expansion at entry to panel.

2.5 FISH CORD

- .1 Polypropylene c/w 3m spare length at each conduit end.

Part 3 Execution

3.1 INSTALLATION

- .1 Install conduits to conserve headroom in exposed locations and cause minimum interference in spaces through which they pass.
- .2 Conceal conduits except in mechanical and electrical service rooms.
- .3 Use rigid galvanized steel threaded conduit where specified.
- .4 Use electrical metallic tubing (EMT) except where specified otherwise.
- .5 Use flexible metal conduit for connection to motors in dry areas, connection to recessed incandescent fixtures without a prewired outlet box, connection to surface or recessed fluorescent fixtures, transformers and equipment subject to vibration or movement. Provide a separate insulated grounding conductor within flexible conduit.
- .6 Use liquid tight flexible metal conduit for connection to motors or vibrating equipment in damp, wet or corrosive locations.
- .7 Install conduit sealing fittings in hazardous areas. Fill with compound.
- .8 Conduit stubs from floor slabs where exposed to damage to be rigid galv. steel.
- .9 The conduit sizes as shown or indicated are the minimum acceptable and shall not be reduced without the approval of the Contract Administrator.
- .10 Bend conduit cold. Replace conduit if kinked or flattened more than 1/10th of its original diameter.
- .11 Mechanically bend steel conduit over 19 mm dia.

- .12 Field threads on rigid conduit must be of sufficient length to draw conduits up tight.
- .13 Install fish cord in empty conduits.
- .14 Where conduits become blocked, remove and replace blocked section. Do not use liquids to clean out conduits.
- .15 Dry conduits out before installing wire.
- .16 Conduit to be sized as per Canadian Electrical Code or as shown on Drawings. Note that the sizes of branch circuit conductors scheduled and/or specified on the Drawings are minimum sizes and must be increased as required to suit length of run and voltage drop in accordance with Canadian Electrical Code. Where conductor sizes are increased to suit voltage drop requirements, increase the conduit size to suit.
- .17 Running threads will not be permitted; proper couplings shall be used.
- .18 Not less than 900mm (3'-0") of flexible conduit (and of sufficient length to allow the lighting fixture to be relocated to any location within a 6 ft. (1.8m) radius) shall be used for the connection of recessed lighting fixtures. A separate drop to be used for each fixture unless fixtures are mounted in continuous rows.
- .19 No circuits fed from emergency or essential power sources shall be run in the same conduit as other systems.
- .20 Provide separate conduit system for emergency distribution.
- .21 All conduit runs passing across expansion joints of the building shall be installed utilizing approved expansion fittings, and bonding devices.
- .22 Refer to 16010 for identification requirements.
- .23 All conduit systems in hazardous areas to be rigid galvanized steel to meet the requirements of the authorities having jurisdiction.

3.2 SURFACE CONDUITS

- .1 Run parallel or perpendicular to building lines.
- .2 Locate conduits behind infrared or gas fired heaters with 1.5 m clearance.
- .3 Run conduits in flanged portion of structural steel.
- .4 Group conduits wherever possible on suspended or surface channels.
- .5 Do not pass conduits through structural members except as indicated.
- .6 Do not locate conduits less than 150 mm parallel to steam or hot water lines with minimum of 75 mm at crossovers.
- .7 No power driven pins (Ramset) shall be utilized to secure any portion of the conduit.

3.3 CONCEALED CONDUITS

- .1 Do not install horizontal runs in masonry walls.
- .2 Do not install conduits in terrazzo or concrete toppings.

3.4 CONDUITS IN CAST-IN-PLACE CONCRETE

- .1 Except with the approval of the Structural Engineer, all conduit runs embedded in concrete shall not be larger in outside diameter than one quarter (1/4) the thickness of the slab, wall, or beam in which they are embedded, nor shall they be spaced closer than three diameters on centre, nor so located as to impair unduly the strength of the construction. Where installed in columns, the conduit shall be placed in the centre of the column and then offset to the outlet box. In no case shall the conduits be placed so that there is less than 25mm of concrete covering. All conduit runs in concrete shall be inspected and approved by Structural Engineer or his representative before concrete is poured. Conduit shall not be embedded in floating concrete slab construction unless specifically indicated otherwise.
- .2 Protect conduits from damage where they stub out of concrete.
- .3 Install sleeves where conduits pass through slab or wall.
- .4 Where conduits pass through waterproof membrane provide oversized sleeve before membrane is installed. Use cold mastic between sleeve and conduit.
- .5 Organize conduits in slab to minimize cross-overs.

3.5 CONDUITS UNDERGROUND

- .1 Slope conduits to provide drainage.

END OF SECTION

Part 1 General

1.1 RELATED WORK SPECIFIED ELSEWHERE

- .1 Section 16010 Electrical General Requirements
- .2 Section 16111 Conduits, Conduit Fastenings and Conduit Fittings
- .3 Section 16191 Fastenings and Support

Part 2 Products

2.1 MATERIALS

- .1 Conductors in Conduit:
 - .1 Type: RW90
 - .2 Conductors:
 - .1 Solid Copper #10 AWG and smaller.
 - .2 Stranded Copper #8 AWG and larger.
 - .3 Sized as indicated (Minimum # 12 AWG).
 - .3 Insulation: cross link polyethylene (RW90), (RWU90), 90 deg. C.
 - .4 Configuration: Single conductor.
 - .5 Voltage Rating: Minimum 600V.
 - .6 Certification: CSA C22.22 No. 38 or latest revision.
- .2 Armored Cable (BX):
 - .1 Type: AC90
 - .2 Conductors:
 - .1 Solid Copper #10 AWG and smaller.
 - .2 Stranded Copper #8 AWG and larger.
 - .3 Sized as indicated (Minimum # 12 AWG).
 - .3 Insulation: cross link polyethylene (XLPE), 90 deg. C.
 - .4 Configuration: Multi-conductor, as required, c/w a separate bare CU ground wire.
 - .5 Voltage Rating: Minimum 600V
 - .6 Certification: CSA C22.22 No. 51 or latest revision.
- .3 Armored Cable (TECK):
 - .1 Type: TECK
 - .2 Conductors:
 - .1 Solid Copper #10 AWG and smaller.
 - .2 Stranded Copper #8 AWG and larger.
 - .3 Sized as indicated (Minimum # 12 AWG).

- .3 Insulation: cross link polyethylene (RW90), 90 deg. C.
- .4 Configuration: Multi-conductor, as required, c/w a separate bare CU ground wire.
- .5 Colour Code: Black, red, blue and white in 4/C cable. Cables of more than 4/C to be number coded.
- .6 Voltage Rating: 1KV, 5KV, or 15KV as indicated.
- .7 Inner Jacket:
 - .1 Black polyvinyl chloride (PVC)
 - .2 Low Flame Spread (LFS)
 - .3 Low Gas Emission (LGE)
- .8 Armor: Inter-locked aluminum
- .9 Outer Jacket:
 - .1 Black polyvinyl chloride (PVC), -40 deg. C
 - .2 Low Flame Spread (LFS)
 - .3 Low Gas Emission (LGE)
- .10 Flame Rating: FT4
- .11 Certification: CSA C22.22 No. 131 or latest revision.
- .4 Electronic Cables:
 - .1 Conductors:
 - .1 Minimum #18 AWG - STC Solid Copper
 - .2 Insulation: polyvinyl chloride (PVC)
 - .3 Configuration: twisted pairs (No. as indicated)
 - .4 Shielding: Copper braid
 - .5 Voltage Rating: 300V
 - .6 Certification: CSA
 - .7 Suitable for use with VFD and DDC controller.
 - .8 Ground the shield as per equipment manufacturer's instructions.
- .5 Low Voltage Control Cables:
 - .1 Type: LVT
 - .2 Conductor: Solid Copper #18 AWG
 - .3 Insulation: Thermoplastic, colour coded
 - .4 Configuration: single, two conductor - parallel, three or more conductors twisted
 - .5 Voltage Rating: 30V
 - .6 Outer Jacket: thermoplastic
 - .7 Certification: CSA C22.22 No. 35
 - .8 Flame Rating: FT4
- .6 RA90 Cables
 - .1 Single conductor RW90 insulation, minimum 600V, -40C
 - .2 Stranded copper, size as indicated.
 - .3 Liquid and vapour tight corrugated aluminum sheath.

- .4 Overall PVC jacket rated FT-4.
- .7 Variable Frequency Drive Power Cables
 - .1 For input power wiring to the VFD and for output wiring to the motor, from the VFD.
 - .2 Use cable specifically designed for Variable Frequency Drives.
 - .1 Teck Drive RX cable as manufactured by Alcatel.
 - .2 PVC jacket rated at FT4.
 - .3 Continuous corrugated impervious aluminum shield.
 - .4 CSA approved to standard C22.2 No. 123-96.
 - .5 Teck Drive RX cables are to be installed in connectors specifically made for use with the Drive RX cables.
 - .6 Terminate the Drive RX cable grounds as per the cable manufacturer's instructions, using ground bushings as directed. The ground connections are to be made at the ground points indicated by the VFD manufacturer. Coordinate with Division 15.
 - .7 Installed as per manufacturer's instructions.

Part 3 Execution

3.1 GENERAL

- .1 To Minimize Voltage Drop
 - .1 All branch circuits including lighting circuits shall be minimum #10 AWG for all circuits longer than 21 metres and shall be minimum #8 for all circuits longer than 35 metres.
 - .2 All branch circuit wiring and conduit shall be installed to minimize voltage drop. Install additional conduit runs as required to take the most direct and shortest route to outlets.

3.2 INSTALLATION IN RACEWAYS

- .1 Install wiring as follows:
 - .1 In conduit systems in accordance with Section 16111.
 - .2 In underground ducts in accordance with Section 16106.
 - .3 In wireways and auxiliary gutters in accordance with Section 16116.
 - .4 Ensure conduits are dry and free of debris before pulling cables.
 - .5 Colour coding and identification as per this section.
 - .6 Wires in outlet, junction and switch boxes, not having a connection within box shall not be spliced, but shall continue unbroken through the box.
 - .7 Branch circuits exceeding 21 metres shall be #10 AWG, branch circuits exceeding 35 metres shall be #8 AWG.

3.3 INSTALLATION OF SINGLE CONDUCTOR CABLES

- .1 Single conductor cables shall be installed one cable diam. apart on suspended cable tray or channel supports and shall be clamped with aluminum cable clamps. Cables shall be

terminated using non-magnetic connectors. Cable armor shall be grounded via an aluminum plate at the supply end and isolated via an insulating plate, at the load end of the cable. A #3/0 AWG bare (unless otherwise noted) copper ground wire shall be installed with each feeder. Cable bending radius shall be at least twelve times the overall cable diam. and bends shall not damage or distort the outer sheath.

- .2 Do not install PVC jacketed cables in circulating air plenums.
- .3 Single conductor cables installed underground shall be installed in the installation configuration outlined in Appendix B of the Canadian Electrical Code to provide the allowable ampacity required for the feeder.

3.4 INSTALLATION OF FLEXIBLE ARMOURED CABLE

- .1 Type AC90 armoured cable (BX) shall be used for connections from conduit systems to recessed luminaires in accessible ceilings. Cable to be of sufficient length to allow the lighting fixture to be relocated to any location within a 6' (1.8M) radius. Cable shall be clamped before entering the lighting fixture and shall be clipped before entering the conduit system junction box.
- .2 Type AC90 armoured cable (BX) shall be used for connections from conduit systems to wiring devices in steel stud partitions and for interconnection of wiring devices within steel stud partitions, cable to be clipped before entering junction or outlet boxes. Cable to be clamped within partitioning with steel galvanized tie-wire.

3.5 INSTALLATION IN EQUIPMENT

- .1 Group and lace-in neatly wire and cable installed in switchboards, panelboards, cabinets, wireways and other such enclosures.

3.6 TERMINATIONS

- .1 Terminate wires and cables with appropriate connectors in an approved manner.

3.7 IDENTIFICATION

- .1 Wire in conduit #2 AWG and smaller shall have solid coloured insulation, color coded as listed below.
- .2 Wire in conduit 1/0 AWG and larger and single conductor cables for normal power feeders shall be identified at each outlet box and termination with a 150 mm band of coloured vinyl tape of the appropriate colour. Emergency power feeders shall be provided with an additional 75 mm band of red vinyl tape installed adjacent to the 150 mm band of the coloured phase identification tape, as listed below. Neutral and ground conductors shall be identified. Paint or other means of colouring the insulation shall not be used.
- .3 Color code wire in conduit and single conductor cables as follows:
 - Phase A - red
 - Phase B - black
 - Phase C - blue
 - Neutral - white

- Ground - green
- .4 Maintain phase sequence and colour coding throughout project.
 - .5 Use colour coded wires in communication cables, matched throughout system.
 - .6 Identify control conductors in motor control equipment, contactors, fire alarm panels, etc. with mylar/cloth wire markers.
 - .7 Refer to 16010 for additional requirements.

END OF SECTION

Part 1 General

1.1 RELATED WORK SPECIFIED ELSEWHERE

- .1 Section 16010 Electrical General Requirements
- .2 Section 16111 Conduits, Conduit Fastenings and Conduit Fittings
- .3 Section 16191 Fastenings & Supports

1.2 LOCATION

- .1 Locate splitters, junction and pull boxes as indicated or as needed for each system.

Part 2 Products

2.1 SPLITTERS

- .1 Sheet metal enclosure, welded corners and formed hinged cover suitable for locking in closed position. Sprinklerproof
- .2 Main and branch lugs to match required size and number of incoming and outgoing conductors as indicated.
- .3 Minimum three spare terminals on each set of lugs in splitters.
- .4 Explosion proof in hazardous areas to suit the hazardous classification.
- .5 Weatherproof where installed outdoors.
- .6 Enclosures in other areas to suit environment.

2.2 JUNCTION AND PULL BOXES

- .1 Welded steel construction with screw-on flat covers for surface mounting.
- .2 Covers with 25 mm minimum extension all around, for flush-mounted pull and junction boxes.
- .3 Cast type with gasketed covers where exposed to weather.

Part 3 Execution

3.1 JUNCTION, PULL BOXES AND CABINETS INSTALLATION

- .1 Install pull boxes in inconspicuous but accessible locations.
- .2 Mount cabinets with top not higher than 2 m above finished floor.

- .3 Install terminal block as indicated.
- .4 Install pull boxes so as not to exceed 30 m of conduit run between pull boxes.
- .5 Install junction and pull boxes clear of all mechanical ductwork and piping.

3.2 IDENTIFICATION

- .1 Provide equipment identification in accordance with Section 16010 - Electrical General Requirements.
- .2 Identify splitters with size 7 nameplates.
- .3 Identify junction and pull boxes with size 3 nameplates.
- .4 Identify cabinets with size 5 nameplates.

END OF SECTION

Part 1 General

1.1 RELATED WORK SPECIFIED ELSEWHERE

- .1 Section 16010 Electrical General Requirements
- .2 Section 16111 Conduits, Conduit Fastenings and Conduit Fittings

Part 2 Products

2.1 OUTLET AND CONDUIT BOXES GENERAL

- .1 Size boxes in accordance with CSA C22.1.
- .2 Sectional boxes shall not be used without specific approval of the Contract Administrator.
- .3 Gang boxes where wiring devices are grouped.
- .4 Blank cover plates for boxes without wiring devices.
- .5 347 V outlet boxes for 347 V switching devices c/w holes on centres to reject all other switches.
- .6 Combination boxes with barriers where outlets for more than one system are grouped.
- .7 In finished areas switch, convenience receptacle, voice/data and blank cover plates shall be stainless steel. In finished area ceilings, junction and pull box covers shall be solid covers, painted to match the finish of the adjacent surface.
- .8 In moist or dusty areas, gasketed watertight or dust tight boxes and covers shall be provided.
- .9 Explosion proof in hazardous areas to suit requirements of authorities having jurisdiction.

2.2 SHEET STEEL OUTLET BOXES

- .1 Electro-galvanized steel device boxes for flush installation, minimum size 102 mm square outlet boxes with extension and plaster rings as required.
- .2 Electro-galvanized steel device boxes for flush installation in drywall and minimum size 102mm square outlet boxes with extension and square cornered tile covers as required.
- .3 Electro-galvanized steel utility boxes for outlets connected to surface-mounted EMT conduit, sized as required for the installation.
- .4 102 mm square or octagonal outlet boxes for lighting fixture outlets.

2.3 MASONRY BOXES

- .1 Electro-galvanized steel masonry single and multi gang boxes for devices flush mounted in exposed block walls.

2.4 CONCRETE BOXES

- .1 Electro-galvanized sheet steel concrete type boxes for flush mount in concrete with matching extension and plaster rings as required.

2.5 CONDUIT BOXES

- .1 Cast FS or FD ferrous alloy boxes with factory-threaded hubs and mounting feet for surface wiring of switches and receptacle where exposed to moisture.

2.6 OUTLET BOXES FOR NON-METALLIC SHEATHED CABLE

- .1 Electro-galvanized, sectional, screw ganging steel boxes, minimum size 76 x 50 x 63 mm with two double clamps to take non-metallic sheathed cables.

2.7 FITTINGS - GENERAL

- .1 Bushing and connectors with nylon insulated throats.
- .2 Knock-out fillers to prevent entry of debris.
- .3 Conduit outlet bodies for conduit up to 32 mm and pull boxes for larger conduits.
- .4 Double locknuts and insulated bushings on sheet metal boxes.

Part 3 Execution

3.1 INSTALLATION

- .1 Support boxes independently of connecting conduits.
- .2 Fill boxes with paper, sponges or foam or similar approved Material to prevent entry of debris during construction. Remove upon completion of Work.
- .3 For flush installations mount outlets flush with finished wall using plaster rings to permit wall finish to come within 6 mm of opening.
- .4 Provide correct size of openings in boxes for conduit, mineral insulated and armoured cable connections. Reducing washers are not allowed.
- .5 Boxes to be mounted plumb and square with building lines.
- .6 Where outlet boxes are shown on the Drawings as being "back-to-back" shall have a minimum offset of 200 mm (8") between boxes to reduce sound transmission. In no case shall "thru-wall" boxes be used.
- .7 Install pull boxes, or fittings, in conduit runs where more than four bends are necessary.

- .8 Install pull boxes where run exceeds 23.0 (75 feet) in length.
- .9 All junction, outlets and pull boxes shall be so installed that they are always readily accessible.
- .10 No power driven pins (Ramset) shall be utilized to secure boxes without specific approval from Contract Administrator.
- .11 Check opening provided for each recessed outlet box and if it is not completely covered by cover plate, report discrepancy to the division responsible and ensure that it is rectified.
- .12 All concealed junction boxes, conduit fittings, etc. to be c/w galv. steel covers, secured with two bolts.
- .13 Co-ordinate boxes in masonry with brick or block configuration, boxes to be saw cut in bottom of appropriate brick or block. They shall be of sufficient depth to allow conduit to pass through center of block.
- .14 Co-ordinate locations with millwork.
- .15 Apply acoustic sealant to and seal wires penetrating moulded vapour barrier boxes.
- .16 Verify exact location of service fittings with furniture Drawings and/or Contract Administrator. Service fittings to be installed parallel and perpendicular to building lines.
- .17 No more than two extension rings shall be used in sequence.

END OF SECTION

Part 1 General

1.1 REFERENCES

- .1 CSA C22.2No.65-1956(R1965) Wire Connectors.
- .2 EEMAC 1Y-2, 1961 Bushing Stud Connectors and Aluminum Adapters (1200 Ampere Maximum Rating).

Part 2 Products

2.1 MATERIALS

- .1 Pressure type wire connectors: with current carrying parts of copper sized to fit copper conductors as required.
- .2 Fixture type splicing connectors: with current carrying parts of copper sized to fit copper conductors 10 AWG or less.
- .3 Clamps or connectors for armoured cable, aluminum sheathed cable, mineral insulated cable, flexible conduit, non-metallic sheathed cable as required.

Part 3 Execution

3.1 INSTALLATION

- .1 Remove insulation carefully from ends of conductors and:
 - .1 Install pressure type wire connectors and tighten.
 - .2 Install mechanical pressure type connectors and tighten screws with appropriate compression tool recommended by manufacturer. Installation shall meet secureness tests in accordance with CSA C22.2 No.65.
 - .3 Install fixture type connectors and tighten. Replace insulating cap.
 - .4 Install bushing stud connectors in accordance with EEMAC 1Y-2.

END OF SECTION

Part 1 General

1.1 RELATED WORK SPECIFIED ELSEWHERE

- .1 Section 16010 Electrical General Requirements
- .2 Section 16111 Conduits, Conduit Fastenings and Conduit Fittings
- .3 Section 16122 Wires and Cables

Part 2 Product

2.1 SUPPORT CHANNELS

- .1 U shape, size 41 x 41 mm, 2.5 mm thick, surface mounted, suspended or set in poured concrete walls and ceilings or as required.
 - .1 Manufacturers: B-Line, Burndy, Electrovert, Unistrut, Pilgrim, Pursley.

Part 3 Execution

3.1 INSTALLATION

- .1 Secure equipment to solid masonry, tile and plaster surfaces with lead anchors.
- .2 Secure equipment to poured concrete with cast in or expandable inserts.
- .3 Secure equipment to hollow masonry walls or suspended ceilings with toggle bolts.
- .4 Secure surface mounted equipment with twist clip fasteners to inverted T bar ceilings. Ensure that T bars are adequately supported to carry weight of equipment specified before installation. Provide additional support as required.
- .5 Support equipment, conduit or cables using clips, spring loaded bolts, cable clamps designed as accessories to basic channel members.
- .6 Fasten exposed conduit or cables to building construction or support system using straps.
 - .1 One-hole malleable iron straps to secure surface conduits and cables 50 mm and smaller.
 - .2 Two-hole steel straps for conduits and cables larger than 50 mm.
 - .3 Beam clamps to secure conduit to exposed steel Work.
- .7 Suspended support systems.
 - .1 Support individual cable or conduit runs with 6 mm dia threaded rods and spring clips.
 - .2 Support 2 or more cables or conduits on channels supported by 6 mm dia threaded rod hangers where direct fastening to building construction is impractical.

- .8 For surface mounting of two or more conduits use channels at 1500 mm oc spacing.
- .9 Provide metal brackets, frames, hangers, clamps and related types of support structures where indicated or as required to support conduit and cable runs.
- .10 Ensure adequate support for raceways and cables dropped vertically to equipment where there is no wall support.
- .11 Do not use wire lashing or perforated strap to support or secure raceways or cables.
- .12 Do not use supports or equipment installed for other trades for conduit or cable support except with permission of other trade and approval of Contract Administrator.
- .13 Install fastenings and supports as required for each type of equipment cables and conduits, and in accordance with manufacturer's installation recommendations.
- .14 Threaded rod to be minimum 6 mm diam. galv. or nickel plated. Black steel rod is not acceptable.

END OF SECTION

Part 1 General

1.1 RELATED WORK SPECIFIED ELSEWHERE

- .1 Division 15000 Mechanical Specifications
- .2 Section 16010 Electrical General Requirements
- .3 Section 16111 Conduits, Conduit Fastenings and Conduit Fittings
- .4 Section 16122 Wires and Cables
- .5 Section 16132 Outlet Boxes, Conduit Boxes and Fittings

1.2 SYSTEM DESCRIPTION

- .1 Provide complete electrical power and control connections for mechanical equipment, except as noted herein.

Part 2 Products

2.1 MATERIALS

- .1 Include disconnects, wire, fittings, and all associated equipment required to provide power wiring for mechanical equipment, unless otherwise indicated.
- .2 Unless otherwise noted, motors, variable frequency drive (VFD) and control devices shall be supplied by Div. 15. Motor horsepower ratings shall be as shown in the Div. 15 Specifications. Motor voltage and phase ratings shall be as shown on the Div. 16 drawings.

2.2 EXTERIOR EQUIPMENT

- .1 All equipment mounted on the exterior of the building shall be weatherproof.

Part 3 Execution

3.1 POWER WIRING

- .1 Install power feeders, disconnects and associated equipment and make connections to all mechanical equipment.
- .2 Install main power feeders to VFD/control panels furnished by Div. 15. Install branch circuit wiring for motors, electric coils, etc.

3.2 CONTROLS

- .1 Section 15900 shall supply and install all conduit, wire, devices and fittings required to wire and connect control systems specified in 15900. Control wiring shall be installed in conduit.

3.3 COORDINATION

- .1 Refer to mechanical drawings for the exact location of motor mechanical equipment requiring an electrical connection.
- .2 Obtain full information from Div. 15, regarding wiring, controls, overload heaters, equipment ratings and overcurrent protection. Notify the Div. 15 subcontractor, at once, if any information provided is incorrect or unsatisfactory.
- .3 Refer to Div. 15 Specifications for any further electrical requirements.

3.4 SHOP DRAWING REVIEW

- .1 Review Div. 15 equipment shop drawings and adjust breaker/feeder sizes as required.

END OF SECTION

Part 1 General

1.1 RELATED WORK SPECIFIED ELSEWHERE

- .1 Section 16010 Electrical General Requirements
- .2 Section 16111 Conduits, Conduit Fastenings and Conduit Fittings
- .3 Section 16132 Outlet Boxes, Conduit Boxes and Fittings
- .4 Section 16191 Fastenings and Supports

1.2 COORDINATION

- .1 The building shall remain open and in normal operation during the construction period.
- .2 Where existing services such as electrical power, fire alarm system, sound system, etc. are required to be disrupted and/or shut down, coordinate the shut-downs with the City and carry out the Work at a time and in a manner acceptable to them. Carefully schedule all disruption and/or shut-downs and ensure that the duration of same is kept to the absolute minimum. Submit for approval a written, concise schedule of each disruption at least 120 hours in advance of performing Work and obtain City's written consent prior to implementing.
- .3 Should any temporary connections be required to maintain services during Work in the existing building, supply and install all necessary Material and equipment and provide all labour at no extra cost. Should any existing system be damaged, make full repairs without extra cost, and to the satisfaction of the City and Contract Administrator.
- .4 If existing equipment shown on drawings is defective it shall be brought to the Contract Administrator and City's attention prior to Work completion.
- .5 Refer to General Conditions for phasing and staging of Work and adhere to that schedule. Comply with instructions regarding Working hours necessary to maintain the building in operation.
- .6 Coordinate complete installation of relocated utility services, if required, with Utilities to ensure minimum interruption of service. Coordinate the transfer of the existing hydro service point to the new service point with the Hydro utility in order to keep power interruptions to a minimum.

1.3 EXISTING DEVICES IN NEW CONSTRUCTION

- .1 Where existing conduits pass vertically through a floor area, relocate those conduits to be installed concealed in a new wall or surface mounted in a service area. Extend conduit, wiring, etc. as required.
- .2 Existing junction boxes in walls and ceiling spaces required to maintain existing circuits shall remain accessible.

- .3 Where services are concealed within walls, floors or ceilings and cannot be visually identified, Contractor shall provide electronic scanning devices or other approved means to locate and identify concealed services prior to drilling.

Part 2 Products

2.1 MATERIALS

- .1 Provide all Materials required for the complete interface and reconnection installation as herein described and as indicated on the drawings.
- .2 New wiring required to interconnect new devices to existing systems shall be provided to suit the manufacturers requirements and instructions.

Part 3 Execution

3.1 INSTALLATION

- .1 Install boxes, conduit and wiring through existing areas as required for the new installation.
- .2 Add modules, switches, etc. in existing control panels, as required, to extend existing systems to new or renovated areas.
- .3 Patch and repair walls and ceilings in existing areas that have been damaged or cut open due to the new electrical installation.
- .4 Where new cables or conduits have been installed through existing fire rated walls, seal opening around cables and conduit to maintain fire rating.

END OF SECTION

Part 1 General

1.1 PRODUCT DATA

- .1 Submit product data in accordance with Section 16010.

Part 2 Products

2.1 DISCONNECT SWITCHES

- .1 Fusible and non-fusible disconnect switch in CSA Enclosure and size as indicated. To suit the environment (i.e. weatherproof, watertight, dust-tight, general purpose, etc.)
- .2 Provision for padlocking in on-off switch position by three locks.
- .3 Mechanically interlocked door to prevent opening when handle in ON position.
- .4 Fuses: size as indicated, to Section 16478 - Fuses - Low Voltage.
- .5 Fuseholders: suitable without adaptors, for type and size of fuse indicated.
- .6 Quick-make, quick-break action, heavy duty industrial grade.
- .7 ON-OFF switch position indication on switch enclosure cover.
- .8 Disconnect switches located at motors connected to variable frequency drives are to be provided with one Form 'C' electrical contact to interlock from the disconnect to the VFD. The interlock is to operate prior to the main power contacts opening to the motor.

2.2 EQUIPMENT IDENTIFICATION

- .1 Provide equipment identification in accordance with Section 16010 - Electrical General Requirements.
- .2 Indicate name of load controlled and voltage on size 6 nameplate.

Part 3 Execution

3.1 INSTALLATION

- .1 Install disconnect switches complete with fuses as indicated.
- .2 Install additional brackets, supports, etc. required for mounting the disconnect switches.

- .3 Provide conduit and wire to interlock between VFD and motor disconnect to power down VFD when motor disconnect is operated.

END OF SECTION

Part 1 General

1.1 RELATED WORK SPECIFIED ELSEWHERE

- .1 Section 16010 Electrical General Requirements
- .2 Section 16122 Wires and Cables

1.2 REFERENCES

- .1 Ground equipment to: CSA C22.2 No. 41.
- .2 Copper grounding conductors to: CSA G7.1.

Part 2 Products

2.1 EQUIPMENT

- .1 Grounding conductors system, circuit and equipment, grounding to be bare (or green insulated if indicated/required) stranded copper sized in accordance with the Canadian Electrical Code.
- .2 System and circuit, equipment, grounding conductors, bare stranded copper, tinned, soft annealed, size as indicated.
- .3 Insulated grounding conductors: green, type RW-90.
- .4 Ground bus: copper, size 50 mm by 6 mm by 300 mm long complete with insulated supports, fastenings, connectors.
- .5 Non-corroding accessories necessary for grounding system, type, size, Material as indicated, including but not necessarily limited to:
 - .1 Grounding and bonding bushings.
 - .2 Grounding or bonding clamps. All grounding and bonding clamps shall be brass where attached to copper pipes. Clamps for other applications shall be of a type and Material that will minimize deterioration from galvanic action due to dissimilar metals.
 - .3 Bolted type conductor connectors.
 - .4 Thermit welded type conductor connectors.
 - .5 Bonding jumpers, straps.
 - .6 Pressure wire connectors.

Part 3 Execution

3.1 INSTALLATION GENERAL

- .1 Install complete permanent, continuous, system and circuit, equipment, grounding systems including, electrodes, conductors, connectors, accessories, as indicated, to conform to requirements of local authority having jurisdiction over installation.
- .2 Install connectors in accordance with manufacturer's instructions.
- .3 Protect exposed grounding conductors from mechanical injury.
- .4 Use mechanical connectors for grounding connections to equipment provided with lugs. Soldered joints not permitted.

- .5 Install bonding wire for flexible conduit, connected at both ends to grounding bushing, solderless lug, clamp or cup washer and screw. Neatly cleat bonding wire to exterior of flexible conduit.
- .6 Install flexible ground straps for bus duct enclosure joints, where such bonding is not inherently provided with equipment.
- .7 Connect building structural steel and metal siding to ground by welding copper to steel.
- .8 Make grounding connections in radial configuration only, with connections terminating at single grounding point street side of water pipe. Avoid loop connections.
- .9 Bond single conductor, metallic armoured cables to cabinet at supply end, and provide non-metallic entry plate at load end.
- .10 Provide separate ground conductors in PVC conduit, plastic or fibreglass raceways.
- .11 All conduit runs containing feeders and branch circuits shall be complete with an insulated green ground wire bonded to all outlet boxes, junction boxes, pull boxes, equipment enclosures, etc. The conduit system shall be continuous but shall not be relied on to serve as the equipment grounding means. Ground conductors shall be sized according to the Canadian Electrical Code, but shall be minimum #12 AWG. All locknuts and couplings shall be securely tightened. All flexible conduit shall include an insulated ground wire and shall be properly grounded through an approved fitting. A separate ground conductor shall be installed in all fibre, PVC or plastic duct runs and shall be connected to maintain the grounding of the system.
- .12 A minimum #3/0 AWG bare ground wire shall be installed in all cable trays.

3.2 SYSTEM AND CIRCUIT GROUNDING

- .1 Install system and circuit grounding connections to neutral points of 600V and 208 V system.

3.3 EQUIPMENT GROUNDING

- .1 Install grounding connections to typical equipment included in, but not necessarily limited to following list. Service equipment, frames of motors, motor control centres, starters, control panels, building steel Work.

3.4 GROUNDING BUS

- .1 Install copper grounding bus mounted on insulated supports on wall of electrical room.
- .2 Ground items of electrical equipment in electrical room to ground bus with individual bare stranded copper connections minimum size #3/0 AWG.

3.5 FIELD QUALITY CONTROL

- .1 Perform tests in accordance with Section 16010.
- .2 Perform ground continuity and resistance tests using method appropriate to site conditions and to approval of the local inspection authority. A report shall be submitted to the Contract Administrator from the testing agency.
- .3 Perform tests before energizing electrical system.
- .4 Disconnect ground fault indicator, if provided, during tests.

- .5 A ground electrode with an unsatisfactory resistance test result shall be altered as necessary until the required resistance reading is achieved.

END OF SECTION

Part 1 General

1.1 RELATED WORK SPECIFIED ELSEWHERE

- .1 Section 16010 Electrical General Requirements

1.2 PRODUCT DATA

- .1 Submit product data in accordance with Section 16010.

Part 2 Products

2.1 BREAKERS GENERAL

- .1 Moulded case circuit breakers: to CSA C22.2 No. 5.
- .2 Bolt-on moulded case circuit breaker: quick- make, quick-break type, for manual and automatic operation with temperature compensation for 40 deg. C ambient.
- .3 Common-trip breakers: with single handle for multi-pole applications.
- .4 Magnetic instantaneous trip elements in circuit breakers to operate only when value of current reaches setting. Trip settings on breakers with adjustable trips to range from 5-10 times current rating.
- .5 Circuit breakers with interchangeable trips as indicated.
- .6 Minimum Interrupting Ratings (RMS Symmetrical) unless otherwise indicated:
 - .1 120/208 Volts - 10,000 Amps
 - .2 347/600 Volts - 14,000 Amps

2.2 THERMAL MAGNETIC BREAKERS

- .1 Moulded case circuit breaker to operate automatically by means of thermal and magnetic tripping devices to provide inverse time current tripping and instantaneous tripping for short circuit protection.

2.3 MANUFACTURERS

- .1 Acceptable manufacturers: To match existing.

Part 3 Execution

3.1 INSTALLATION

- .1 Install circuit breakers as indicated.

END OF SECTION