

1 SECTION - WINDOW / BULKHEAD
A2/A10 SCALE: 1"=1'-0"
GENERAL OFFICE B-03 & OFFICE B-02
SHOWERS / LOCKERS B-06 & B-10

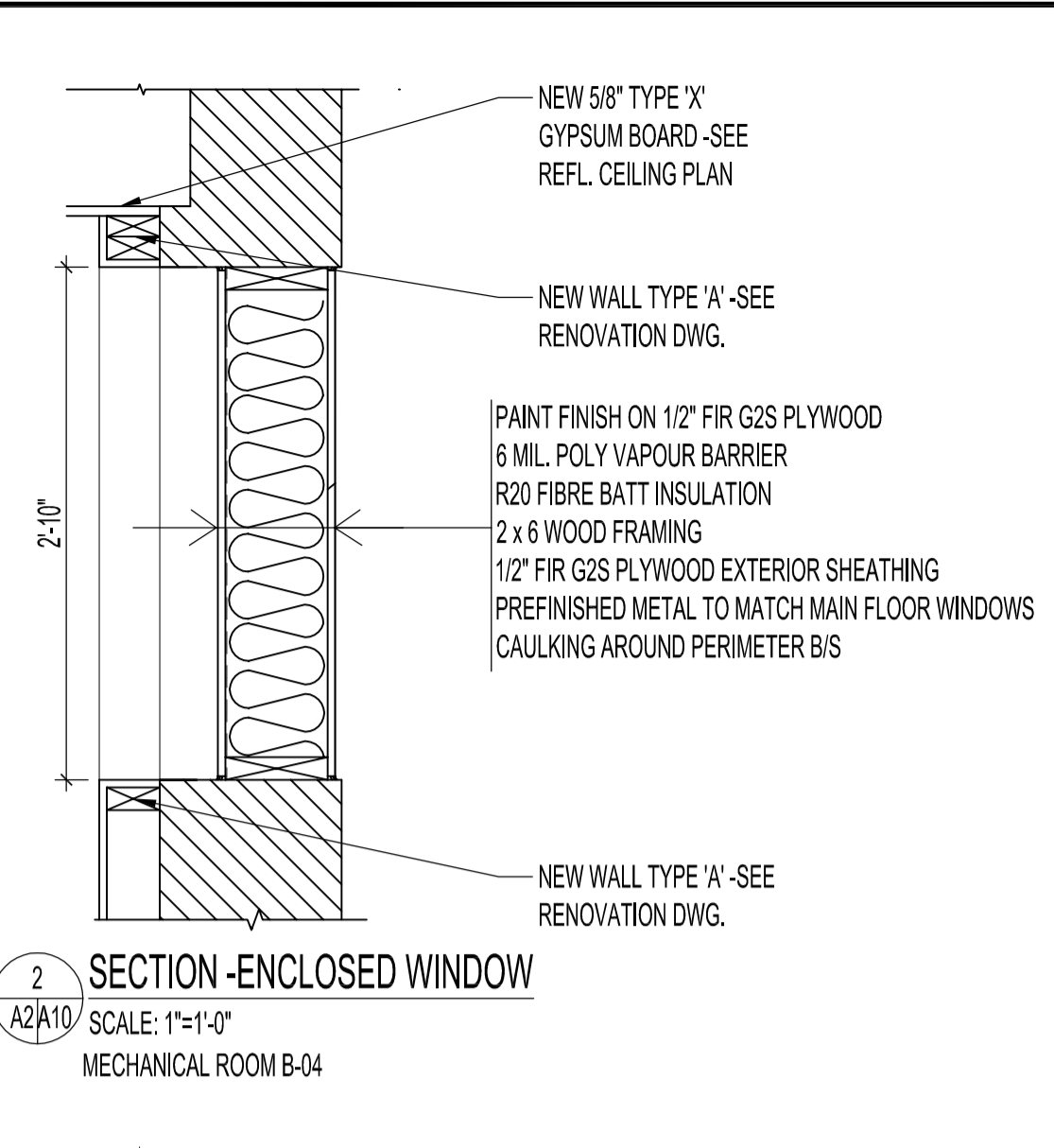

2 SECTION - ENCLOSED WINDOW
A2/A10 SCALE: 1"=1'-0"
MECHANICAL ROOM B-04

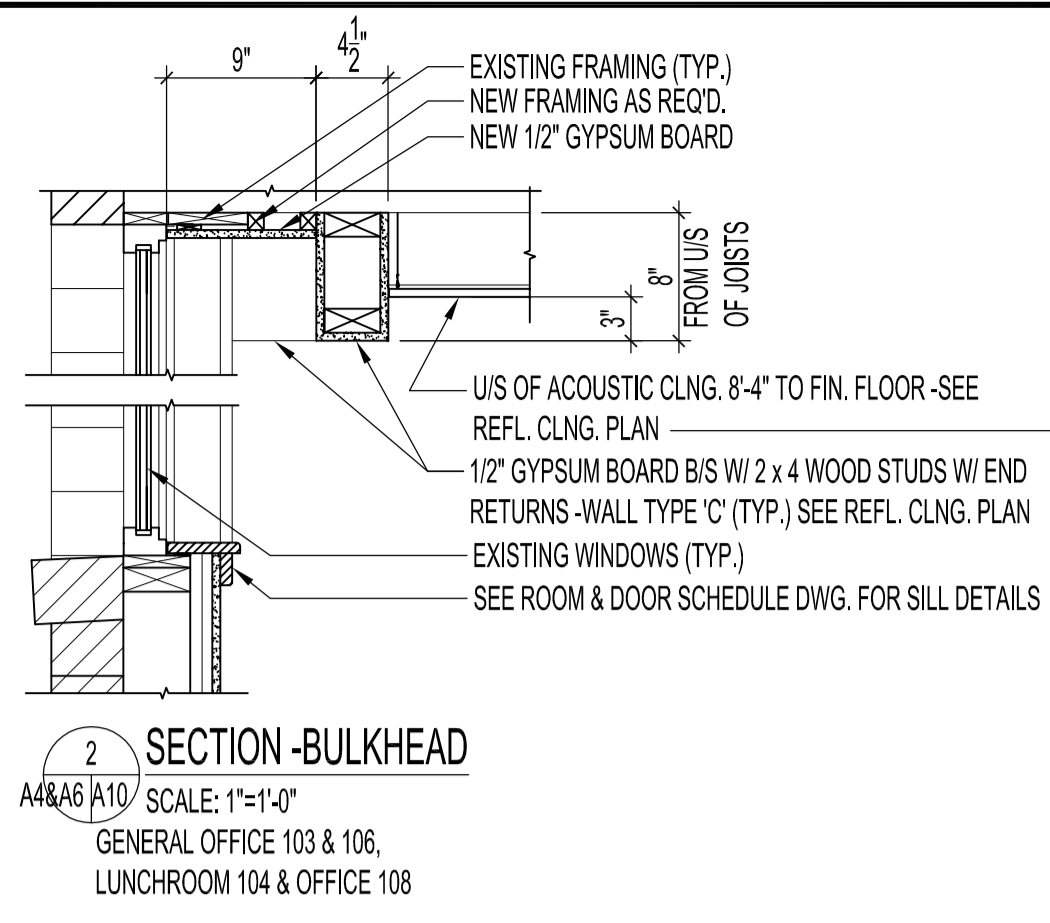

2 SECTION - BULKHEAD
A4&A6/A10 SCALE: 1"=1'-0"
GENERAL OFFICE 103 & 106,
LUNCHROOM 104 & OFFICE 108

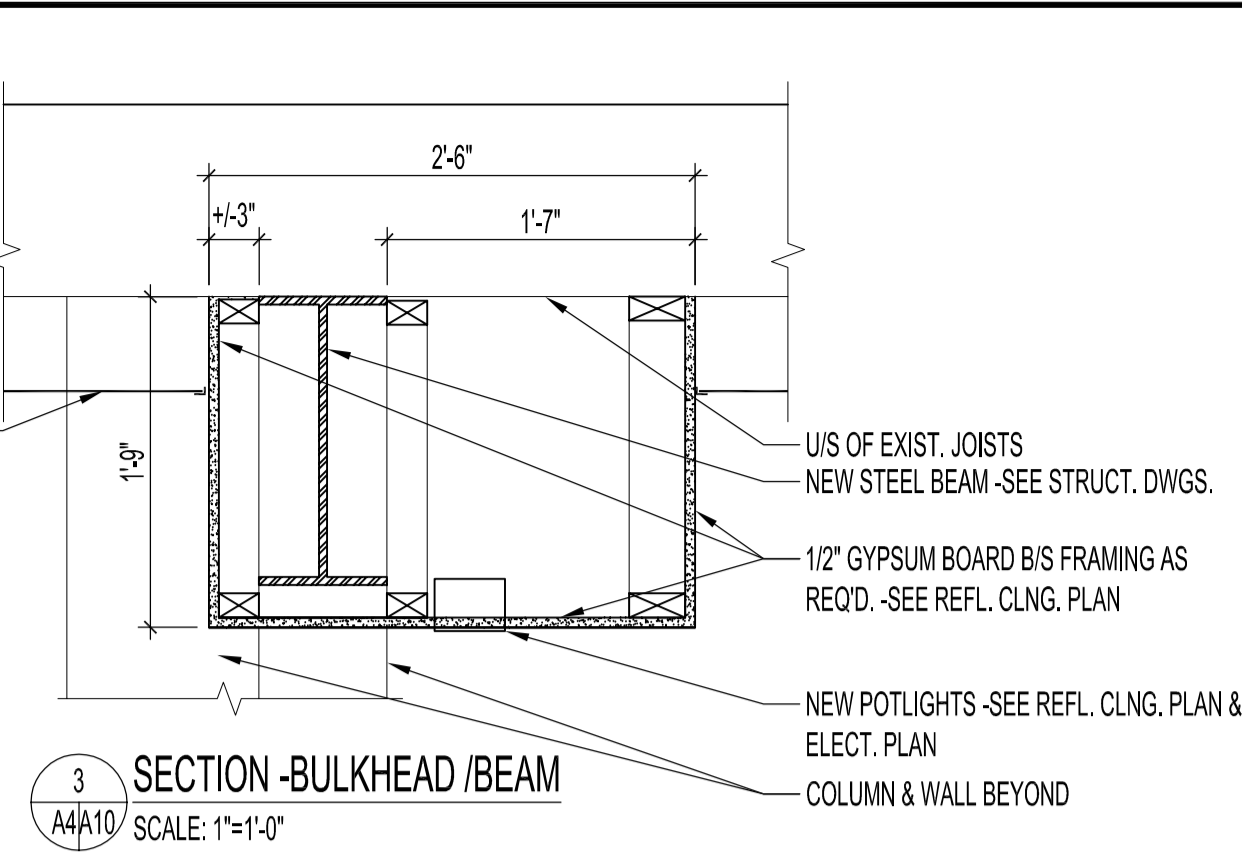

3 SECTION - BULKHEAD / BEAM
A4/A10 SCALE: 1"=1'-0"

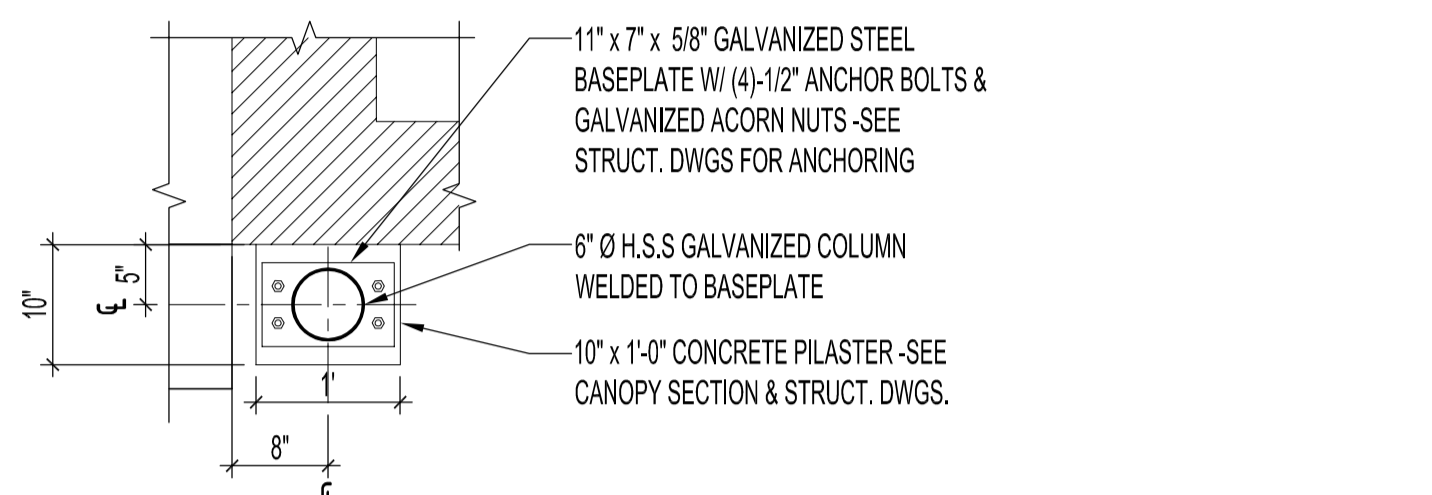

5 DETAIL - EXTERIOR COLUMN BASE
A3/A10 SCALE: 3/4"=1'-0"

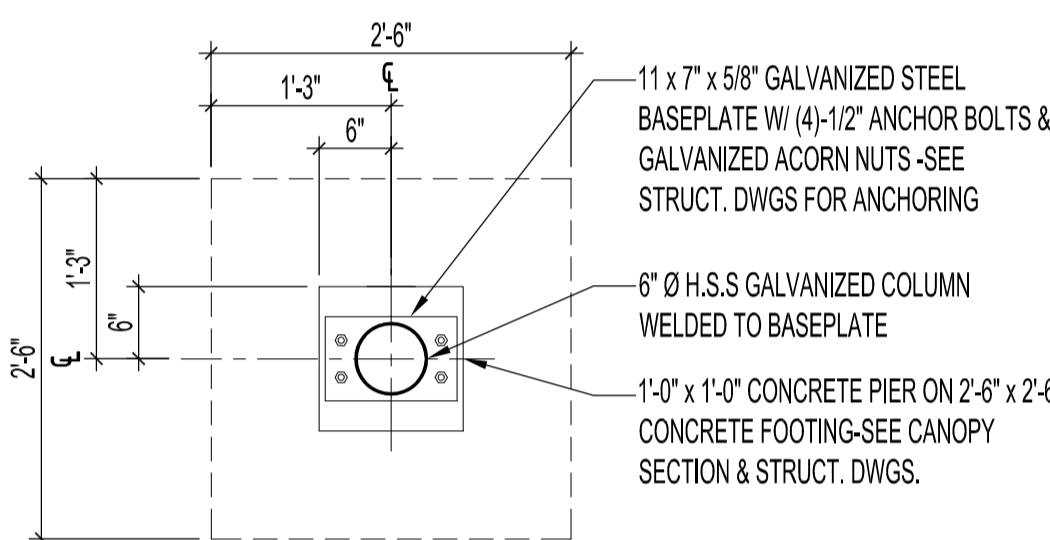

6 DETAIL - EXTERIOR COLUMN BASE
A3/A10 SCALE: 3/4"=1'-0"

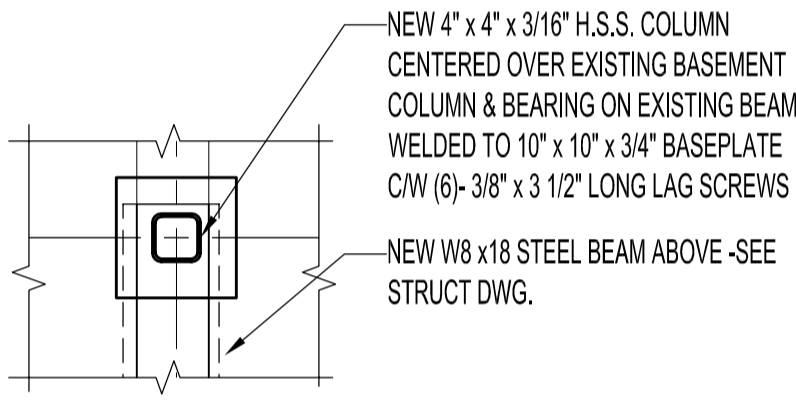

7 DETAIL - INTERIOR COLUMN BASE
A3/A10 SCALE: 3/4"=1'-0"

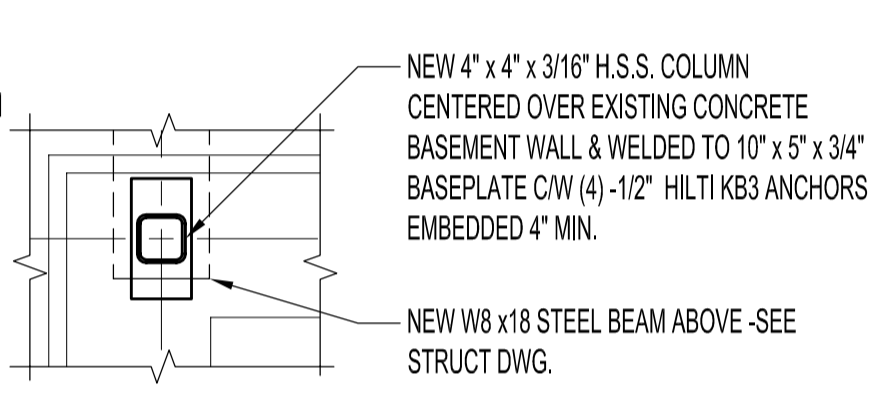

8 DETAIL - INTERIOR COLUMN BASE
A3/A10 SCALE: 3/4"=1'-0"

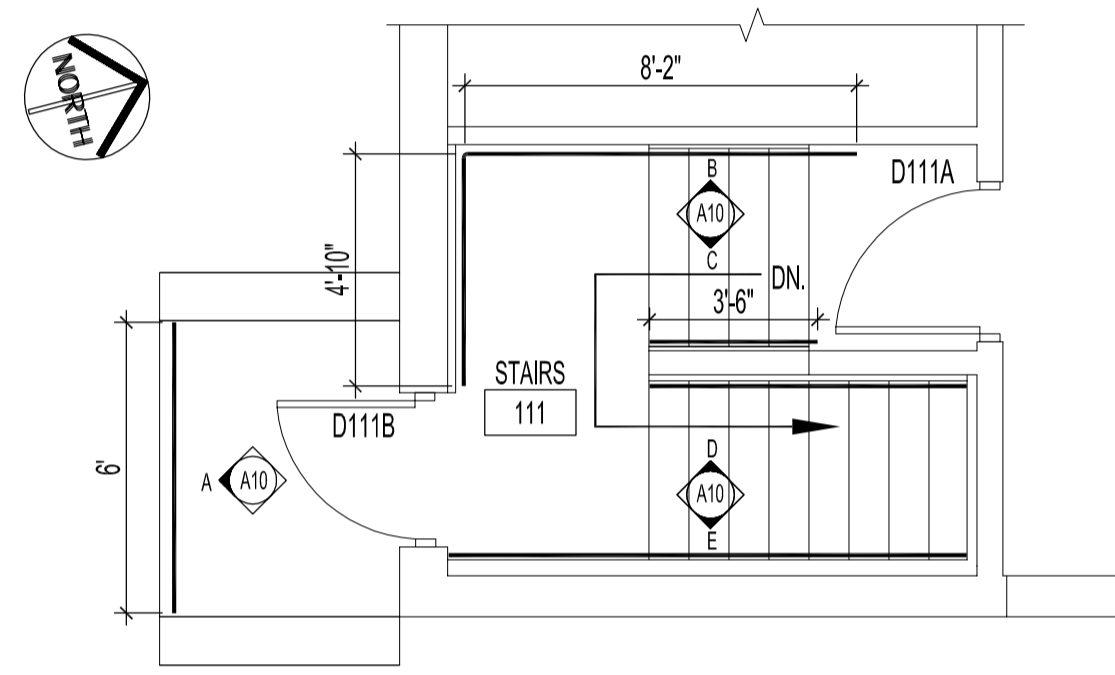

SOUTH EXIT STAIR & STAIRWAY 111
SCALE: 1/4"=1'-0"

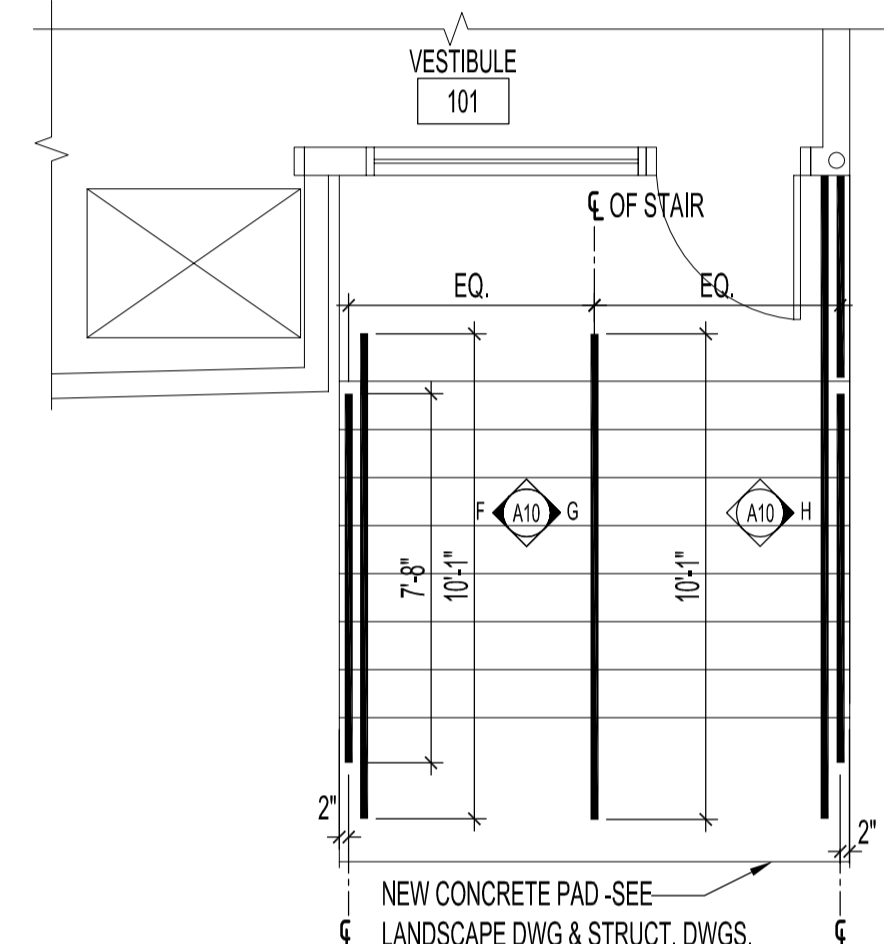

FRONT ENTRANCE STAIR
SCALE: 1/4"=1'-0"

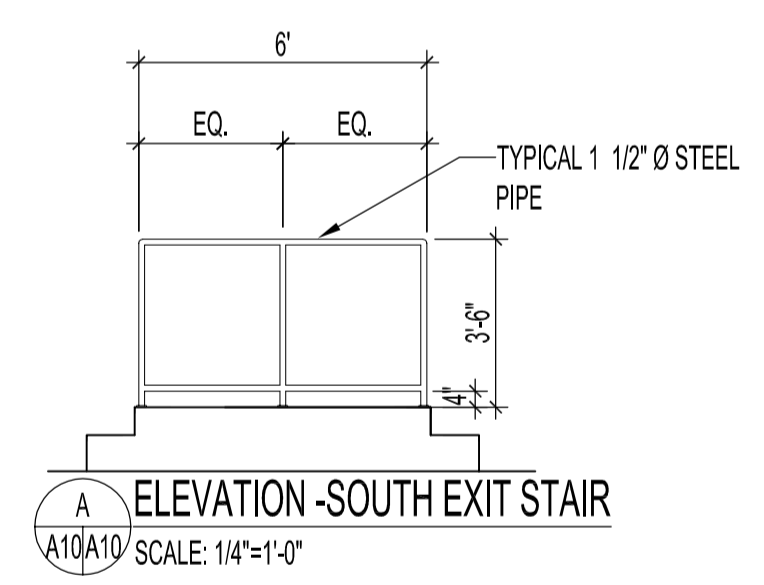

A ELEVATION - SOUTH EXIT STAIR
A10A10 SCALE: 1/4"=1'-0"

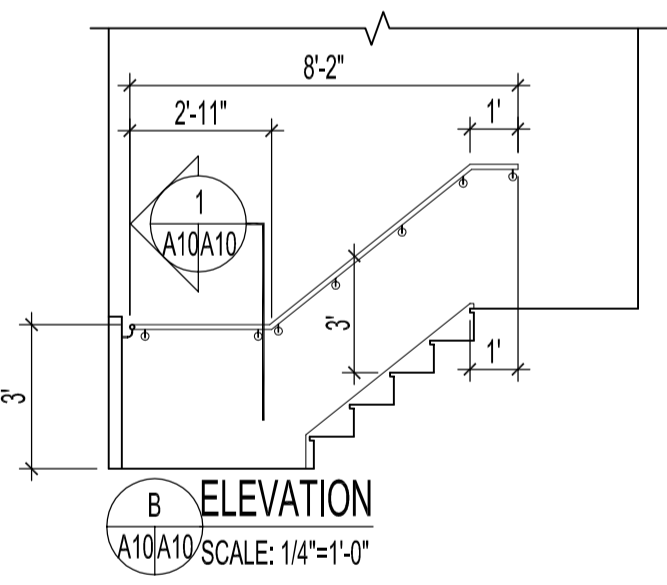

B ELEVATION
A10A10 SCALE: 1/4"=1'-0"

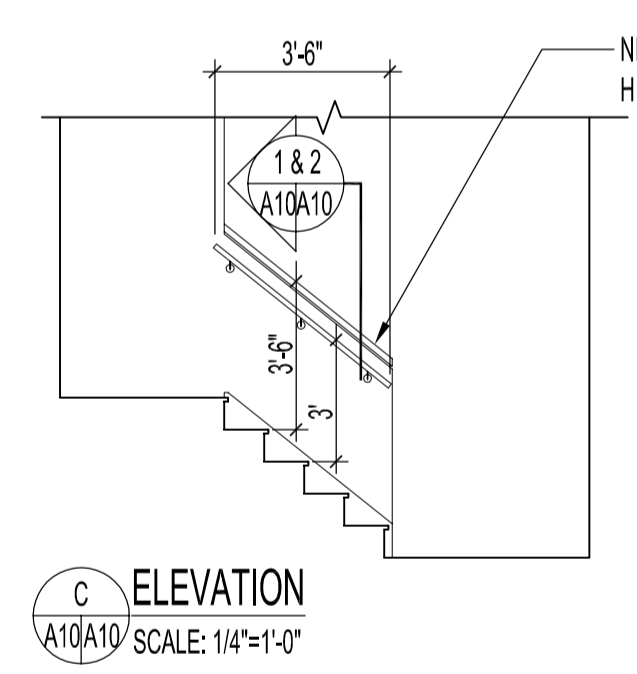

C ELEVATION
A10A10 SCALE: 1/4"=1'-0"

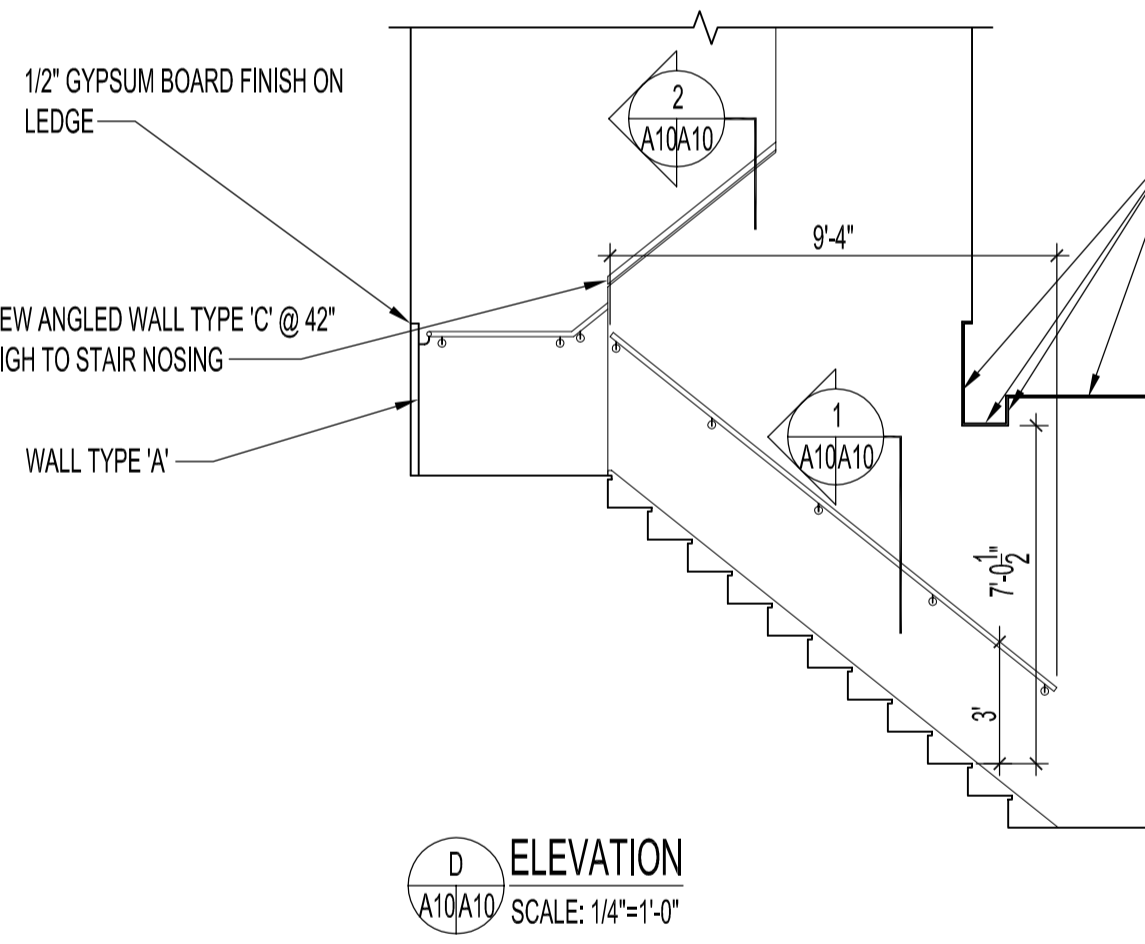

D ELEVATION
A10A10 SCALE: 1/4"=1'-0"

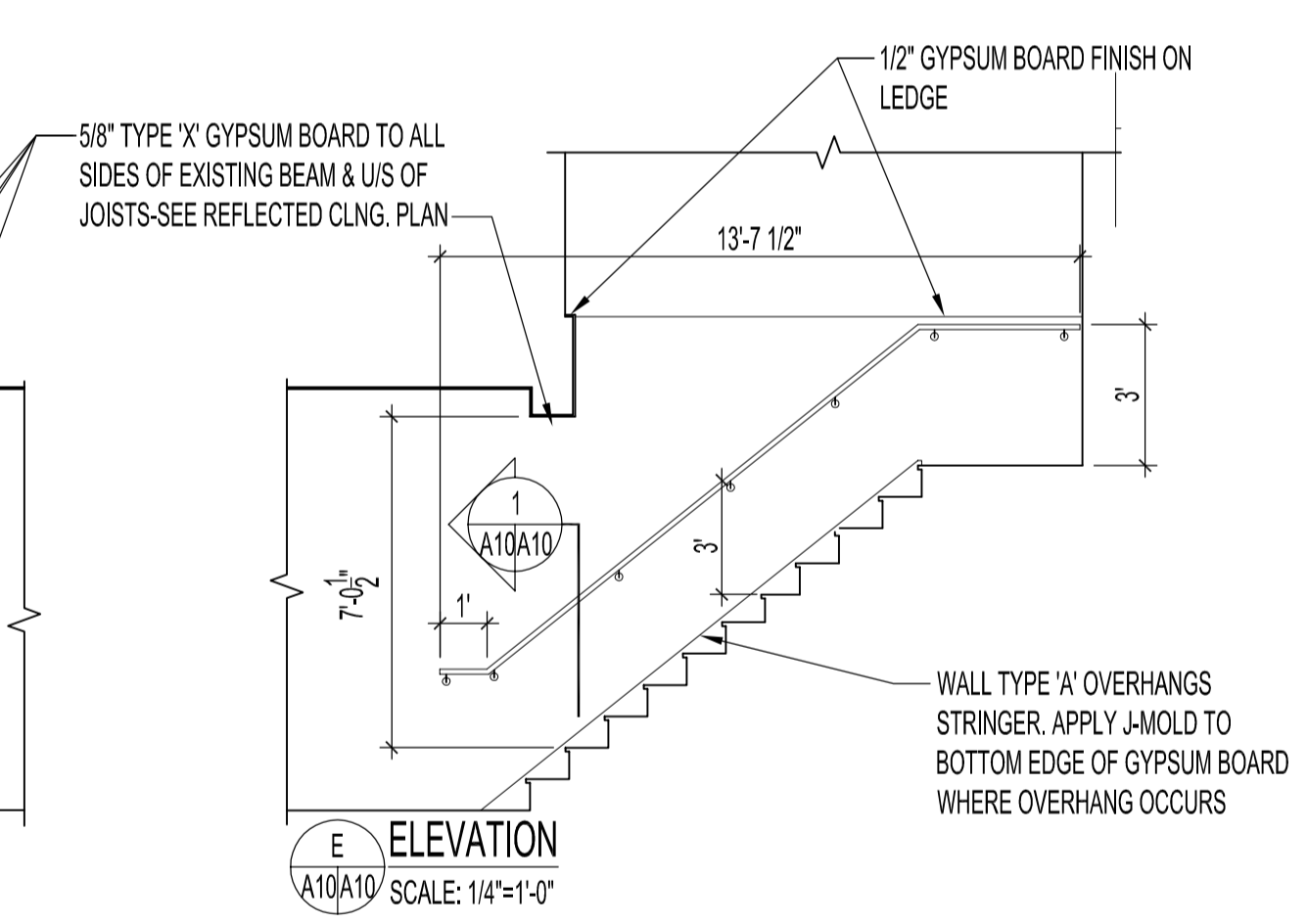

E ELEVATION
A10A10 SCALE: 1/4"=1'-0"

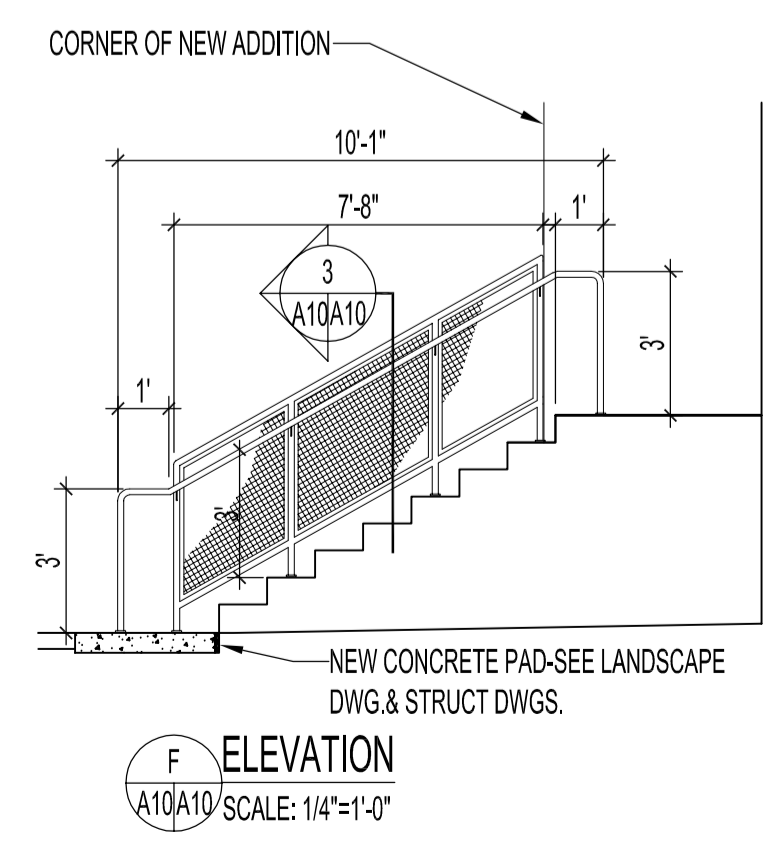

F ELEVATION
A10A10 SCALE: 1/4"=1'-0"

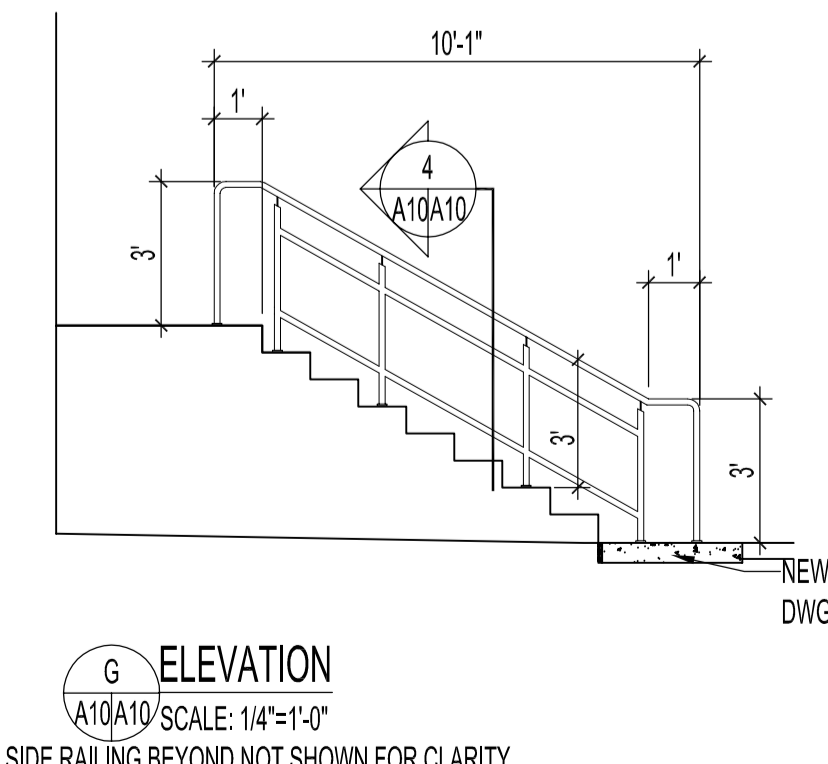

G ELEVATION
A10A10 SCALE: 1/4"=1'-0"
SIDE RAILING BEYOND NOT SHOWN FOR CLARITY

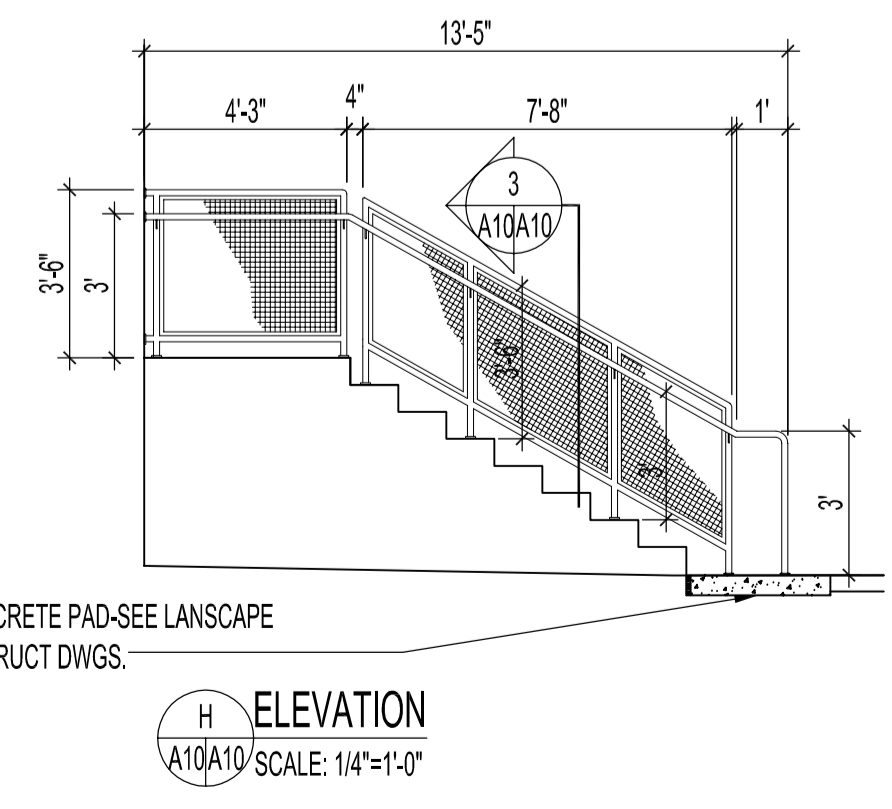

H ELEVATION
A10A10 SCALE: 1/4"=1'-0"

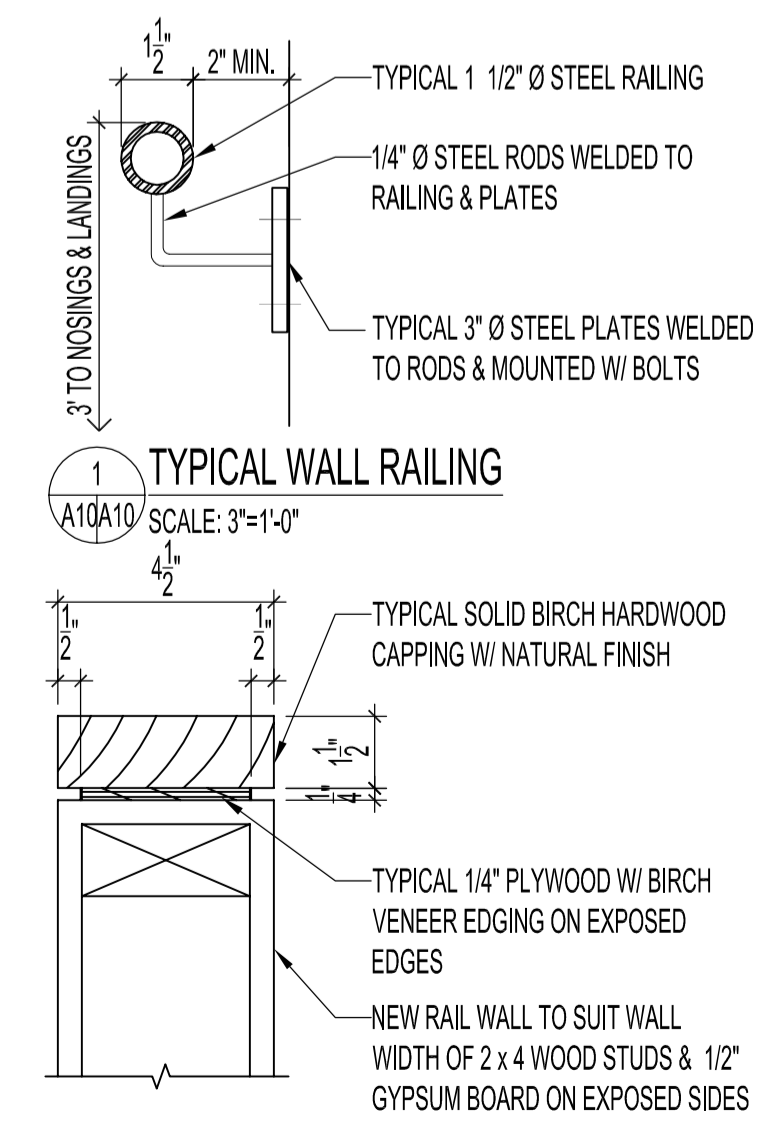

1 TYPICAL WALL RAILING
A10A10 SCALE: 3"=1'-0"

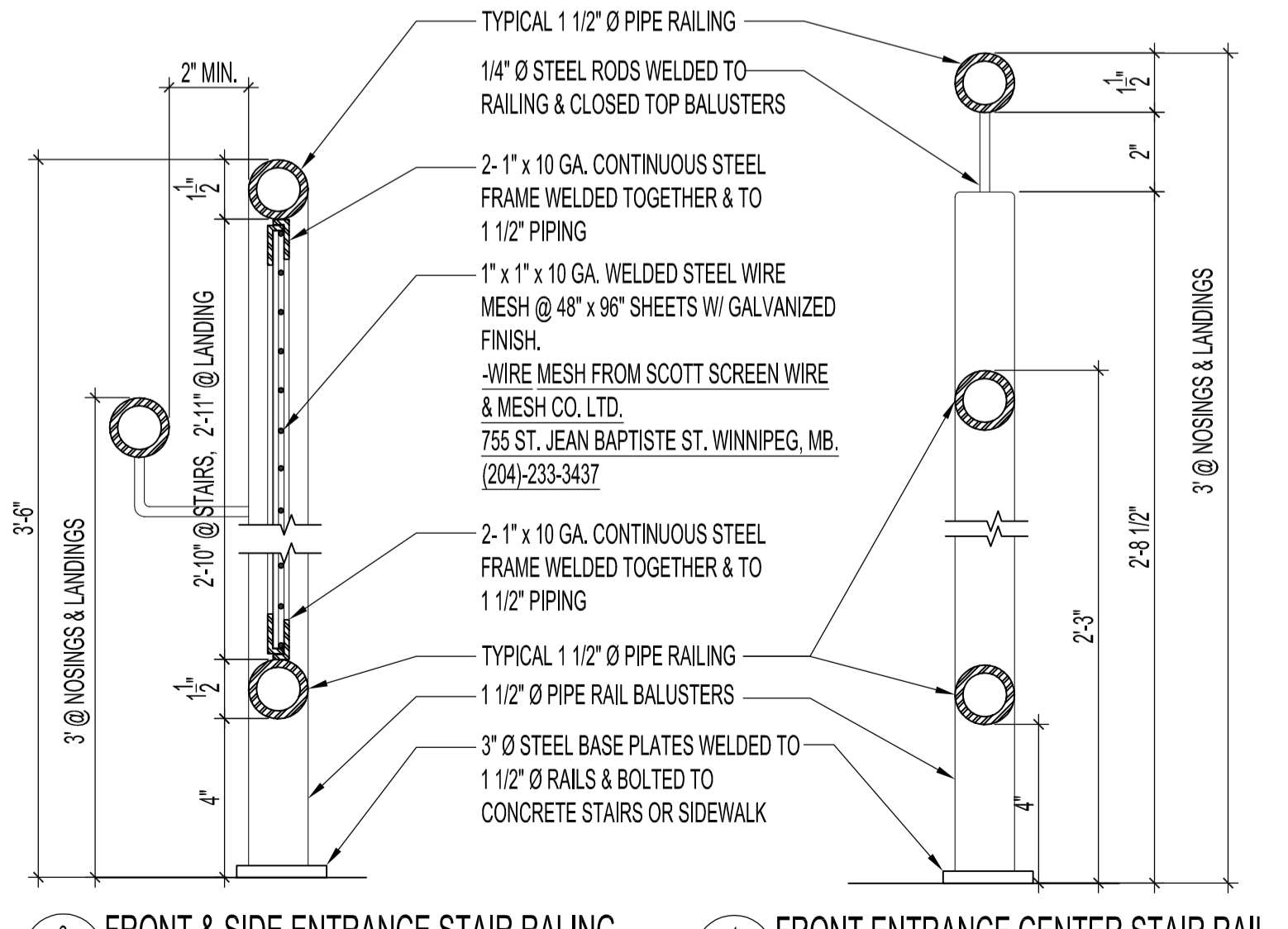

3 FRONT & SIDE ENTRANCE STAIR RAILING
A10A10 SCALE: 3"=1'-0"

4 FRONT ENTRANCE CENTER STAIR RAIL
A10A10 SCALE: 3"=1'-0"

NOTES :
ALL EXTERIOR STAIR RAILINGS, WIRE MESH & COMPONENTS TO BE GALVANIZED METAL FINISH.
ALL INTERIOR RAILINGS & COMPONENTS TO BE PAINTED.

ORIGINAL STAMPED BY: R.K.FOK LI Arch.
DATE: 2007.10.15

NO.	REVISION/DESCRIPTION	BY	DATE
SEALS			

DRAWN BY: MMK
CHECKED BY: USER APPROVAL
DATE: 2007.10.05
CITY OF WINNIPEG
PLANNING, PROPERTY & DEVELOPMENT DEPARTMENT
CIVIC ACCOMMODATIONS DIVISION
300 - 65 GARRY ST. R3C 4K4

PROJECT: COMMUNITY POLICE SERVICE CENTRE
1400 HENDERSON HIGHWAY
SHEET TITLE: BULKHEAD & COLUMN SECTIONS, STAIR PLANS, ELEVATIONS & DETAILS

SCALE	PROJECT NO.	SHEET NO.
AS SHOWN	2004-023	A10

DRAWING SHEET SIZE: A1 (841mm x 594mm) PLOT 1:1