

**NOTE:**  
 1. All timber dimensions are approximate. Final dimensions may alter slightly to attain required CSA safety distances around the play components. Final layout to be approved by Contract Administrator.  
 2. All New Tree locations approximate. To be determined with Contract Administrator on site.  
 3. All dimensions in metres.

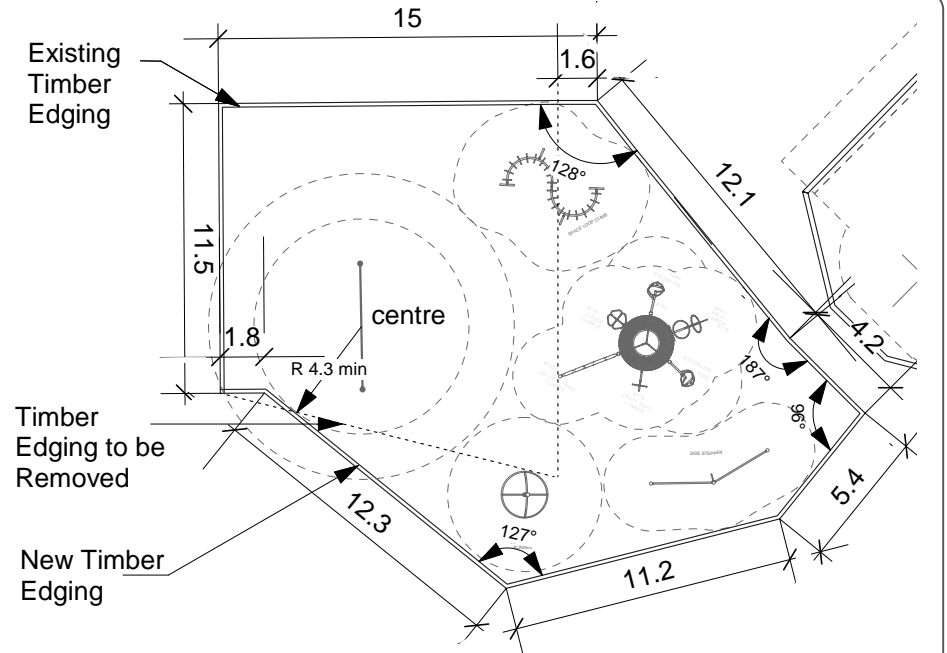

**1** South Area Timber Edging Layout Plan  
 S.32-E5 1:300

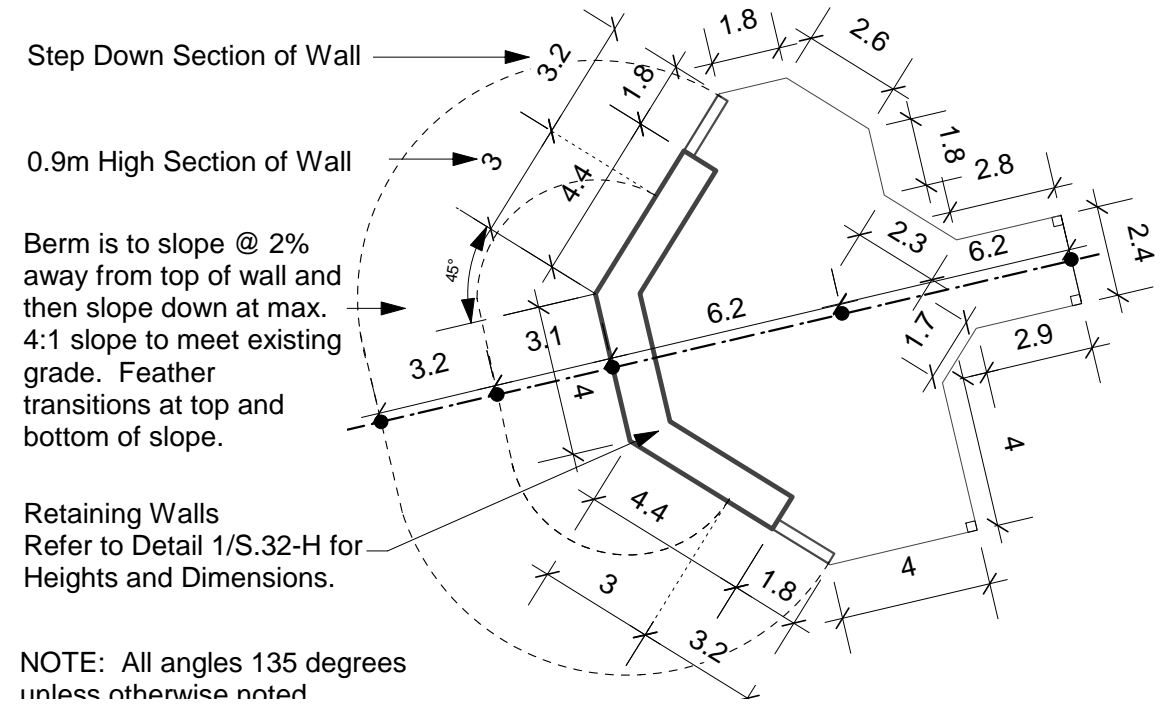

**2** Pisa Stone Retaining Wall Layout Plan  
 S.32-E5 1:200

CONTRACTOR TO CONFIRM ALL DIMENSIONS AND REPORT ANY DISCREPANCIES TO CONTRACT ADMINISTRATOR PRIOR TO CONSTRUCTION. LOCATION OF UNDERGROUND STRUCTURES AS SHOWN ARE BASED ON THE BEST INFORMATION AVAILABLE BUT NO GUARANTEE IS GIVEN THAT ALL EXISTING UTILITIES ARE SHOWN OR THAT THE GIVEN LOCATIONS ARE EXACT. CONFIRMATION OF EXISTENCE AND EXACT LOCATION OF ALL SERVICES MUST BE OBTAINED FROM THE INDIVIDUAL UTILITIES BEFORE PROCEEDING WITH CONSTRUCTION.



THE CITY OF WINNIPEG  
 Planning, Property and Development Department  
 Planning and Land Use Division  
 Unit 15 - 30 Fort Street, Winnipeg, MB, (R3C 4X5)

DESIGNED BY	CH/DB	CHECKED BY	
DRAWN BY	ST/DB	APPROVED BY	
HORIZ. SCALE	1:300		
VERT. SCALE			
DATE	July/07		

MANAGER, PARK AND OPEN SPACES	DATE
MANAGER, PLANNING AND LAND USE DIVISION	DATE

DRAWING TITLE	DRAWING NO.
<b>SHAMROCK SCHOOL SITE REDEVELOPMENT</b>	
<b>Proposed Site Development</b>	
<b>Layout Plan - South Area</b>	<b>S.32-E5</b>
SITE ADDRESS	BID OPPORTUNITY NO.
831 Beaverhill Rd	<b>309-2007</b>