

A B C D E F G H

1

2

3

4

5

6

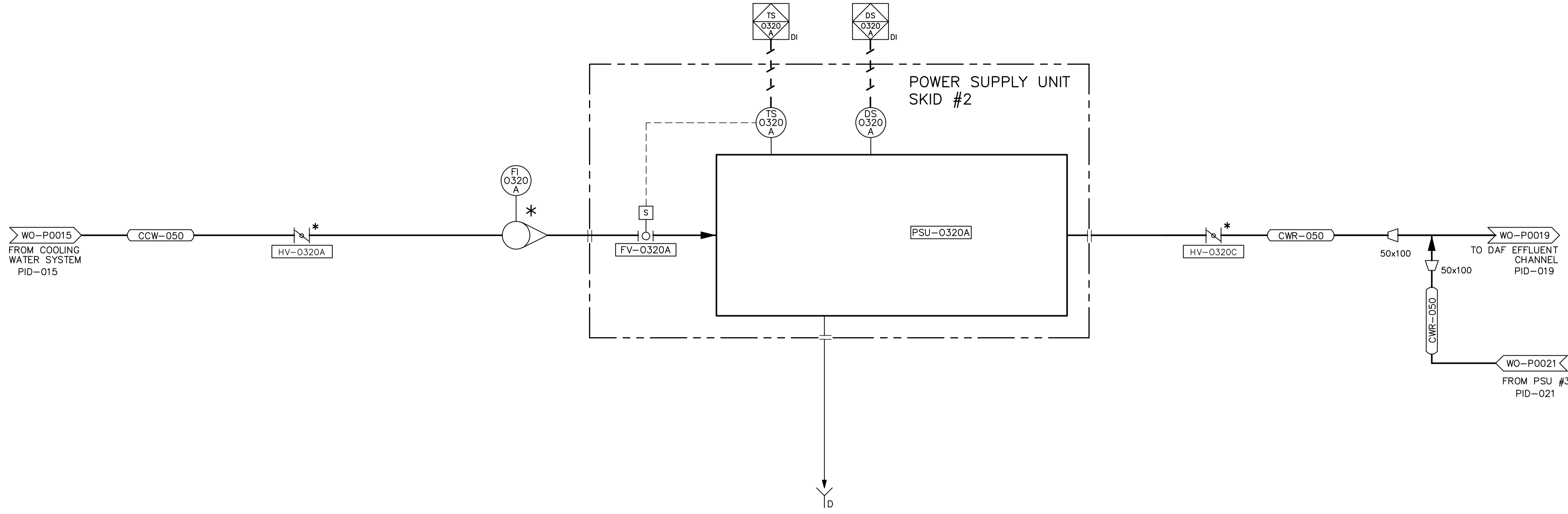

- NOTES:**
1. ALL ASTERISK ITEMS ARE FUJI'S SCOPE OF SUPPLY.
  2. ALL ITEMS WITHIN SKID BOUNDARY ARE FUJI'S SCOPE OF SUPPLY.
  3. ALL ASTERISK ITEMS WITHOUT SKID BOUNDARY ARE SUPPLIED LOOSE.

Rev. No.	Description	By	Date
REV 6	PER ENGR COMMENTS	S.L.A.	3/1/06
REV 5	PER ENGR COMMENTS	S.L.A.	2/8/06
REV 4	PER ENGR COMMENTS	D.L.V.	1/22/06
REV 3	PER ENGR COMMENTS	D.L.V.	1/18/06
REV 2	PER ENGR COMMENTS	D.L.V.	1/4/06
REV 1	PER ENGR COMMENTS	S.L.A.	12/14/05

Date	Name
12/08/05	S.L.A.

**Checked**

**Fuji Electric Co.,Ltd.**

THE CITY OF WINNIPEG WATER AND WASTE DEPARTMENT ENGINEERING DIVISION		Dwg.No.	WPMB-PID-020
Title PROCESS & INSTRUMENTATION DIAGRAM POWER SUPPLY UNIT #2		Ref.	Fuji Project No.: WPMB-1105 City of Winnipeg 428-2005

A B C D E F G H



NO.	REVISIONS	DATE	BY
01	ISSUED FOR CONSTRUCTION	06/07/28	CBE
00	ISSUED FOR TENDER	06/03/29	CBE

DESIGNED BY	SB/CBE	CHECKED BY	EPM
DRAWN BY	TLL	APPROVED BY	AHL
SCALE:	NTS	RELEASED FOR CONSTRUCTION BY:	R. SOROKOWSKI
DATE	2005/06/01	DATE	2006/03/29

ENGINEER'S SEAL  
 ORIGINAL SIGNED BY  
 D.J. PERNITSKY  
 2006/03/29  
 CONSULTANT DRAWING NO.  
 WO-P0020

**THE CITY OF WINNIPEG**  
 WATER AND WASTE DEPARTMENT  
 ENGINEERING DIVISION

WATER TREATMENT PLANT  
 OZONE  
 MECHANICAL AND ELECTRICAL

OZONATION AREA  
 POWER SUPPLY UNIT NO. 2  
 PROCESS AND INSTRUMENTATION DIAGRAM

CITY FILE NUMBER  
 SHEET OF  
 CITY DRAWING NUMBER  
 1-06010-G-P0020-001-010