

ABORIGINAL READING IN THE ROUND
supported by Moffat Family Fund

Eq 1

1.34 Type F.20.2 DF: 11" and 6" matte black graphics applied to 2" thick x 20' x 2' deep susp. panel. Shows both faces.

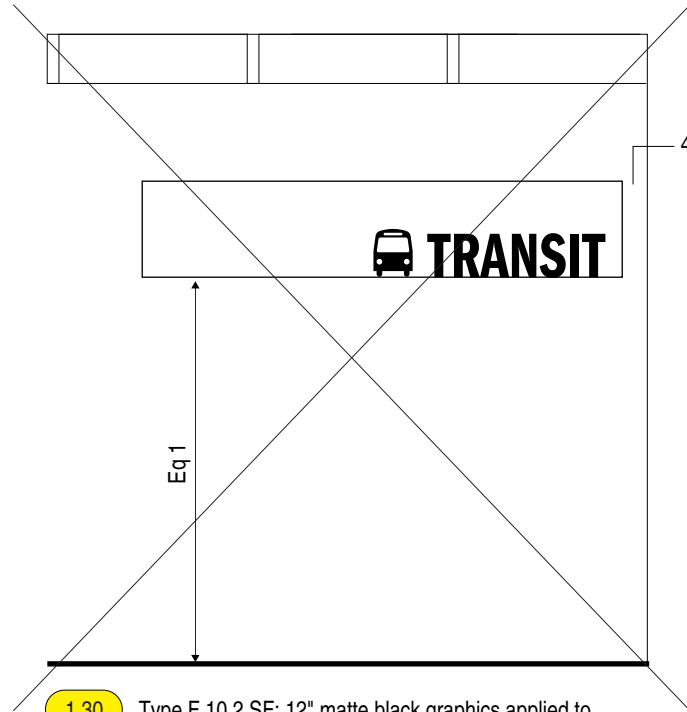

4" gap to wall.

1.30 Type F.10.2 SF: 12" matte black graphics applied to 2" thick x 10' x 2' deep susp. panel.

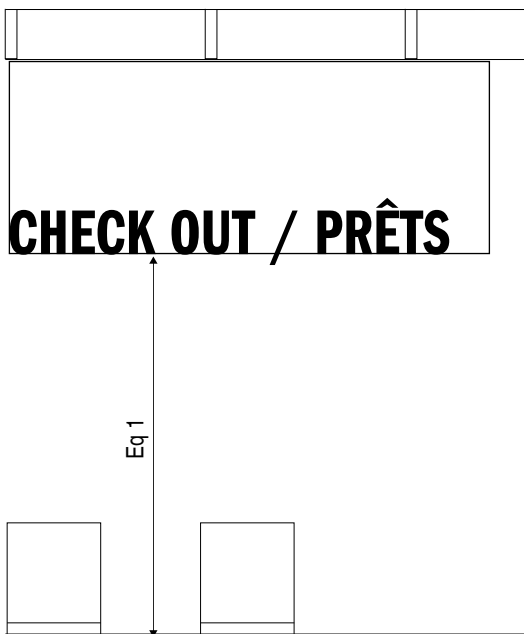

1.31 Type F.10.4 DF: 12" matte black graphics applied to 2" thick x 10' x 4' deep susp. panels. Shows both faces. 2 signs req'd.

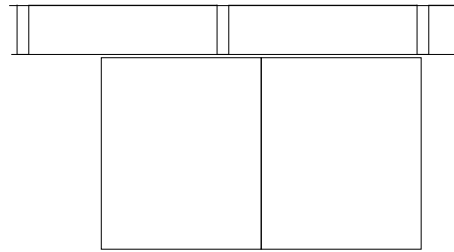

End elevation

1.33 Type F.40.4 SF: 11" and 6" matte black graphics applied to 2" thick x 40' x 4' deep susp. panel. Four (4) 90° folds.

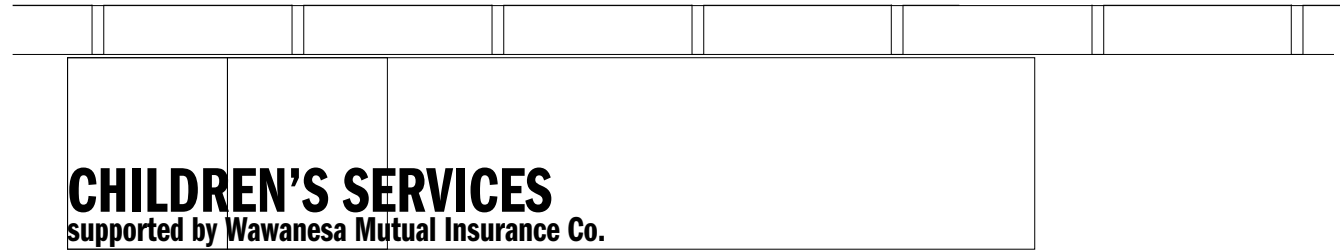
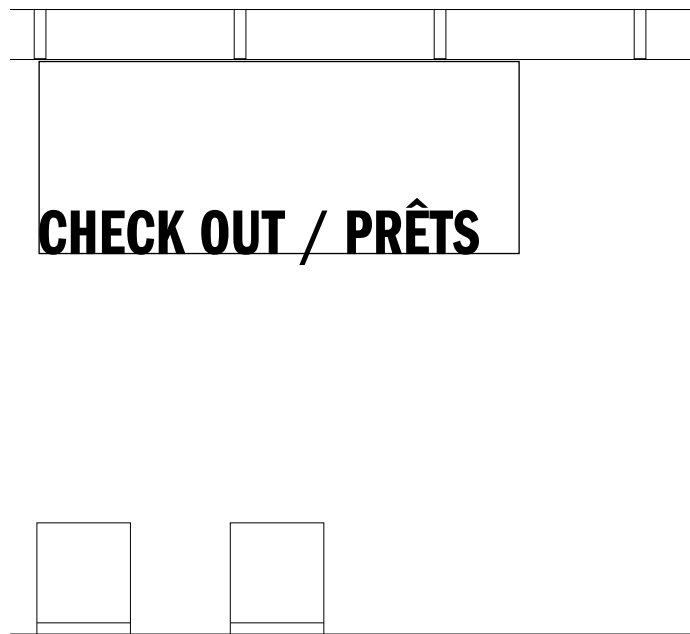

Front elevation

1.33F Type S.8, DF Freestanding Stack Indicator: See DWg. S.02, V.03.

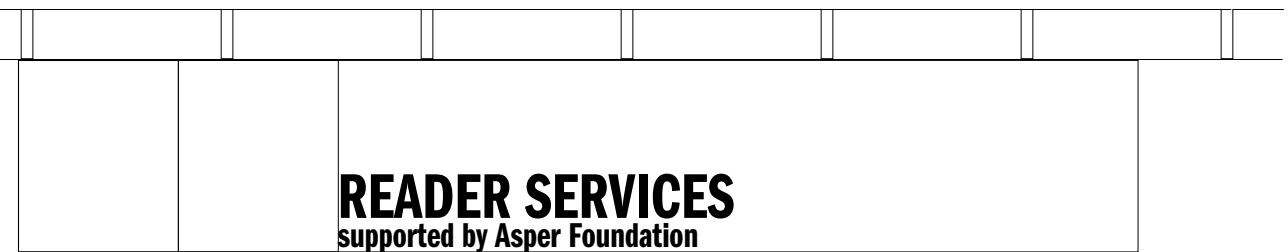
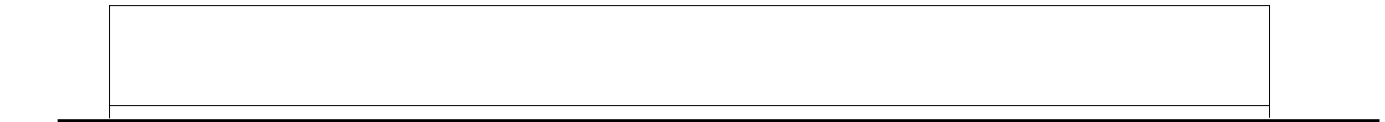
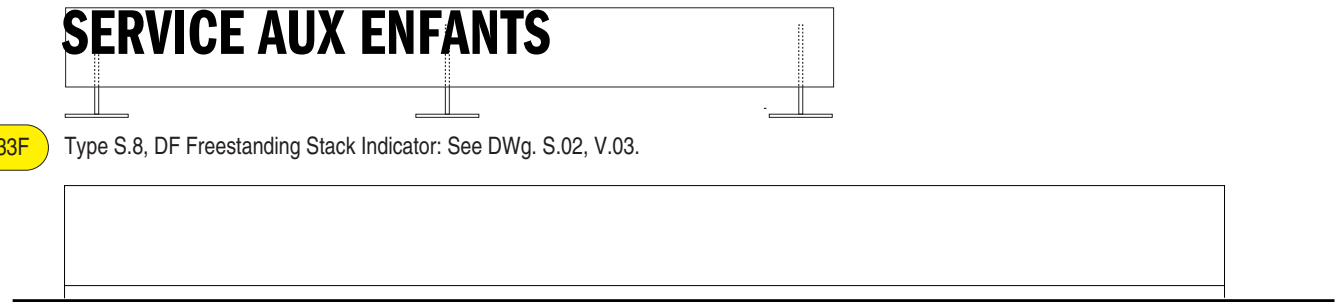

Front and back elevation

1.32F Type S.8, DF Freestanding Stack Indicator: See DWg. S.02, V.03.

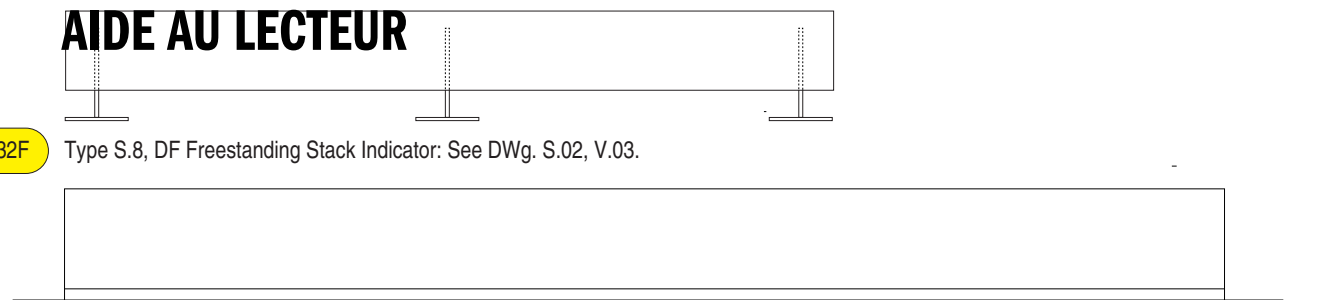

1.32 Type F.40.4 DF: 11" and 6" matte black graphics applied to 2" thick x 40' x 4' deep susp. panel. Four (4) 90° folds. Shows both faces.

Gallop/Varley
3574 W 13th Avenue
Vancouver, B.C.
Canada V6R 2S3
T: 604 736 1895
F: 604 736 1896
e: gallopvarley@shaw.ca

This document contains information proprietary to Gallop/Varley and shall not be reproduced or transferred to other documents, or disclosed to others, or used for any purpose other than that for which it is intended without the prior written permission of Gallop/Varley.

1. Site survey req'd.
2. Submit FS paper layouts (pen plots) on request.
3. Submit samples as requested.
4. Type style is ITC Franklin Gothic Demi Compressed.
5. All sign locations to be site confirmed.
6. All messages t.b.c. by Owner.
7. A small, rough model of each sign will be provided to the successful contractor.

A 05/09/19 Add Sign 1.32F. Signs 1.31, 1.33: add Fr.

Revisions:

Date: 05/09/01

Scale: 1/4" = 12"
Note: horiz. dim. n.t.s.

Project No: 707

Project:
Millennium Library
Winnipeg MB
Sign Program

Dwg. Title:
Level 1
Bulkhead Graphics
Suspended Signs

Sign Type: F

Dwg. No: F.01

A