

Red River Community Centre

293 Murray Ave.
Winnipeg, Manitoba

March 23, 2005 Issued for Tender

SPECIFICATION R-1

Set No. _____
Bid No. 197-2004

TABLE OF CONTENTS

Division 0 - Bid Documents

| | |
|--|----------|
| Section 00085 – Index and Detail Sheets..... | 53 Pages |
| Section 00200 – Information Available to Bidders | 28 Pages |
| Section 00301 – Separate Prices | 2 Pages |
| Section 00860 – Room Finish Schedule..... | 1 Page |
| Section 00870 – Door and Hardware Schedule..... | 5 Pages |
| Section 00872 – Door and Frame Schedule..... | 5 Pages |

Division 1 - General Requirements

| | |
|---|---------|
| Section 01011 – Mitigation Measures..... | 3 Pages |
| Section 01110 - Summary of Work..... | 2 Pages |
| Section 01330 – Submittal Procedures | 4 Pages |
| Section 01355 – Waste Management and Disposal | 4 Pages |
| Section 01420 - References..... | 4 Pages |
| Section 01450 - Quality Control..... | 3 Pages |
| Section 01510 – Temporary Utilities..... | 3 Pages |
| Section 01520 – Construction Facilities..... | 3 Pages |
| Section 01560 - Temporary Barriers and Enclosures | 2 Pages |
| Section 01561 - Environmental Protection..... | 2 Pages |
| Section 01610 - Basic Product Requirements | 5 Pages |
| Section 01705 – Health and Safety | 3 Pages |
| Section 01720 - Preparation..... | 3 Pages |
| Section 01740 - Cleaning | 3 Pages |
| Section 01770 - Closeout Procedures | 2 Pages |
| Section 01780 - Closeout Submittals..... | 7 Pages |
| Section 01810 - Commissioning | 2 Pages |

Division 2 - Site Work

| | |
|---|---------|
| Section 02115 – Sitework Demolition | 2 Pages |
| Section 02222 - Excavation..... | 2 Pages |
| Section 02223 - Backfilling | 4 Pages |
| Section 02311 - Site Grading | 2 Pages |
| Section 02451 – Bored Piles | 2 Pages |
| Section 02511 - Watermains | 2 Pages |
| Section 02530 – Sewer Services..... | 1 Page |
| Section 02622 - Foundation and Underslab Drainage | 3 Pages |
| Section 02631 – Manholes and Catchbasins..... | 2 Pages |
| Section 02775 – Concrete Curbs..... | 2 Pages |
| Section 02821 – Chain Link Fences and Gates | 4 Pages |
| Section 02911 – Topsoil and Finish Grading | 4 Pages |
| Section 02921 – Mechanical Seeding | 3 Pages |
| Section 02933 - Sodding | 3 Pages |

Division 3 - Concrete

| | |
|--|---------|
| Section 03100 – Concrete Formwork | 4 Pages |
| Section 03200 – Concrete Reinforcement | 1 Page |
| Section 03300 – Cast-In-Place Concrete..... | 3 Pages |

Division 4 - Masonry

| | |
|---|---------|
| Section 04051 – Masonry Procedures..... | 4 Pages |
| Section 04060 - Mortar and Masonry Grout..... | 2 Pages |
| Section 04090 – Masonry Accessories..... | 2 Pages |
| Section 04220 – Concrete Masonry Units | 1 Pages |
| Section 04233 – Random Ashlar Limestone..... | 4 Pages |
| Section 04300 – Unit Masonry | 2 Pages |

Division 5 - Metals

| | |
|--|---------|
| Section 05500 - Metal Fabrications | 4 Pages |
|--|---------|

Division 6 - Wood and Plastics

| | |
|---|---------|
| Section 06100 - Rough Carpentry Long Form | 5 Pages |
| Section 06171 – Prefabricated Wood Trusses..... | 3 Pages |
| Section 06201 - Finish Carpentry | 6 Pages |
| Section 06400 - Architectural Woodwork..... | 6 Pages |
| Section 06666 - Plastic Laminates | 4 Pages |

Division 7 - Thermal and Moisture Protection

| | |
|---|---------|
| Section 07120 - Bituminous Dampproofing | 4 Pages |
| Section 07190 – Vapour and Air Barriers | 4 Pages |
| Section 07212 - Board Insulation..... | 3 Pages |
| Section 07213 - Batt and Blanket Insulation | 2 Pages |
| Section 07311 – Asphalt Shingles..... | 4 Pages |
| Section 07450 – Mineral Fiber Siding..... | 3 Pages |
| Section 07465 – Preformed Metal Siding | 2 Pages |
| Section 07550 – Modified Bituminous Roofing | 6 Pages |
| Section 07620 - Sheet Metal Flashing and Trim | 2 Pages |
| Section 07840 - Fire Stopping | 4 Pages |
| Section 07900 – Joint Sealers..... | 6 Pages |

Division 8 - Doors and Windows

| | |
|---|---------|
| Section 08110 - Steel Doors and Frames..... | 9 Pages |
| Section 08120 - Aluminum Doors and Frames | 4 Pages |
| Section 08330 – Rolling Shutters | 1 Page |
| Section 08520 – Aluminum Windows | 3 Pages |
| Section 08620 – Fiberglass Windows..... | 4 Pages |
| Section 08710 - Door Hardware | 5 Pages |

Section 08800 - Glazing 5 Pages
Section 08950 – Translucent Glazing Units 7 Pages

Division 9 - Finishes

Section 09225 - Stucco 3 Pages
Section 09250 – Gypsum Wall Board 5 Pages
Section 09330 - Porcelain Tile..... 2 Pages
Section 09651 - Resilient Flooring..... 6 Pages
Section 09911 - Interior Painting 14 Pages
Section 09912 - Exterior Painting 11 Pages

Division 10 - Specialties

Section 10170 – Plastic Toilet Partitions..... 3 Pages
Section 10800 - Toilet, Bath and Laundry Accessories..... 4 Pages
Section 10999 – Miscellaneous Specialties 3 Pages

Division 15 - Mechanical

Section 15010 – Mechanical General Provisions..... 20 Pages
Section 15051 – Acceptable Materials & Equipment 4 Pages
Section 15180 – Insulation 8 Pages
Section 15400 – Plumbing..... 14 Pages
Section 15600 – Liquid Heat Transfer 11 Pages
Section 15800 – Air Distribution 22 Pages
Section 15900 – Controls / Instrumentation 20 Pages
Section 15990 – Testing, Adjusting & Balancing 5 Pages

Mechanical Schedules

- MS-1A Air Handling Unit Schedule
- MS-1B Air Handling Unit Schedule
- MS-2 Fan Schedule
- MS-3 Expansion Tank Schedule
- MS-4 Glycol Heat Recovery Schedule
- MS-5 Pump Schedule
- MS-6 Condensing Unit Schedule

- MD-1 Water Service Entry Detail
- MD-2 Domestic Water Heater Detail
- MD-3 Submersible Sump Pump Detail
- MD-4 Sission Joint Detail
- MD-5 Deleted
- MD-6 Pipe Support Detail
- MD-7 Grit Interceptor Pit Detail

Division 16 - Electrical

Section 16050 Basic Electrical Materials and Methods..... 9 Pages

| | |
|---|---------|
| Section 16111 Conduit | 3 Pages |
| Section 16120 Wire and Cable | 3 Pages |
| Section 16126 Fastening and Supports | 2 Pages |
| Section 16131 Cabinets, Splitters, Junction and Pullboxes | 2 Pages |
| Section 16134 Outlet Boxes and Fittings | 2 Pages |
| Section 16140 Wiring Devices | 3 Pages |
| Section 16151 Mechanical Equipment Connections | 2 Pages |
| Section 16160 Panelboards | 2 Pages |
| Section 16170 Motor and Circuit Disconnects | 2 Pages |
| Section 16182 Circuit Breakers | 1 Page |
| Section 16183 Miscellaneous Apparatus and Appliances | 1 Page |
| Section 16402 Underground Services | 1 Page |
| Section 16421 Service Entrance Board | 4 Pages |
| Section 16440 Disconnect Switches – Fused and Non-Fused up to 1000V | 1 Page |
| Section 16451 Grounding | 2 Pages |
| Section 16500 Lighting | 3 Pages |
| Section 16519 Exit Lights | 1 Page |
| Section 16535 Unit Equipment for Emergency Lighting | 3 Pages |
| Section 16723 Fire Alarm System (Single Stage Addressable) | 6 Pages |
| Section 16741 Data Systems Copper – Cat #5 (Enhanced) | 5 Pages |
| Section 16800 Electric Heating | 2 Pages |
| Section 16811 Motor Starters to 600V | 4 Pages |
| Section 16819 Grouped Motor Control | 3 Pages |
| Electrical Schedules | |
| Heater Schedule | 1 page |
| Luminaire Schedule | 2 pages |
| Heater Schedule | 1 page |
| Motor Schedule | 2 pages |
| Electrical Panel Schedule 'A' | 1 page |
| Electrical Panel Schedule 'B' | 1 page |
| Electrical Panel Schedule 'RL' | 1 page |

END OF SECTION

ARCHITECTURAL DETAILS

- DA-01 Plan Detail @ Vest. 101
- DA-02 Plan Detail @ Vest. 101
- DA-03 Plan Detail @ Vest. 101
- DA-04 Jamb Detail @ Skate Change 102
- DA-05 Plan Detail @ Grid 3 and B
- DA-06 Plan Detail @ Grid 1 and F
- DA-07 Plan Detail @ Grid 2 and C
- DA-08 Plan Detail @ Grid 3 and C
- DA-09 Plan Detail @ Grid 1 and G
- DA-10 Typical Exterior Panel Elevation
- DA-10A Typical Exterior Panel – Vertical and Inside Corner Detail
- DA-10B Typical Exterior Panel – Horizontal and Outside Corner Detail
- DA-10C Typical Exterior Panel – at Window Heads and Jambs
- DA-10D Typical Exterior Panel – at Masonry and Panel Connection
- DA-10E Typical Exterior Panel – at Stucco and Metal Siding Connection
- DA-11 Plan Detail – Typical Window Jamb
- DA-12 Plan Detail @ Grid 2 and E
- DA-13 Plan Detail @ Grid 2 and E (at roof)
- DA-14 Plan Detail @ Grid 3 and C (at roof)
- DA-15 Typical Rain Water Leader Detail
- DA-16 Typical Solar Shade - Section
- DA-17 Typical Eave Section
- DA-18 Soffit Section
- DA-19 Typical Foundation Section at Masonry
- DA-20 Typical Foundation Section at Fibre Cement Panels
- DA-21 Typical Window Sill / Head
- DA-22 Typical Window Sill / Head at Vented Wall
- DA-23 Typical Vented Roof to Wall
- DA-24 Typical Vented Wall to Roof
- DA-25 Lexan Protection at Aluminum Window
- DA-26 Lexan Protection at Fibreglass Window
- DA-27 Lexan Protection at Aluminum Curtainwall
- DA-28 Gymnasium Game Lines Layout
- DA-29 Typical Gable End
- DA-30 Typical Entry Roof Gable End
- DA-31 Entry Roof Prow
- DA-32 Light Fixture Guard
- DA-33 W/C Tile Pattern
- DA-34 Strawboard Elevation @ Window
- DA-35 Typical Solar Shade - Plan
- DA-36 Typical Round Wood Bollard
- DA-37 Typical Light Proof Barrier / Fence

MILLWORK DETAILS

- DM-01 W.C. Vanity
- DM-02 Upper & Lower Cabinet Section
- DM-03 Upper Cabinet Section
- DM-04 Merchandise Display Cabinet
- DM-05 Bench & Hook Details
- DM-06 Counter Shutter Section
- DM-07 Display Case
- DM-08 Strawboard Paneling Detail
- DM-09 Soda Machine Enclosure

**VESTIBULE
101**

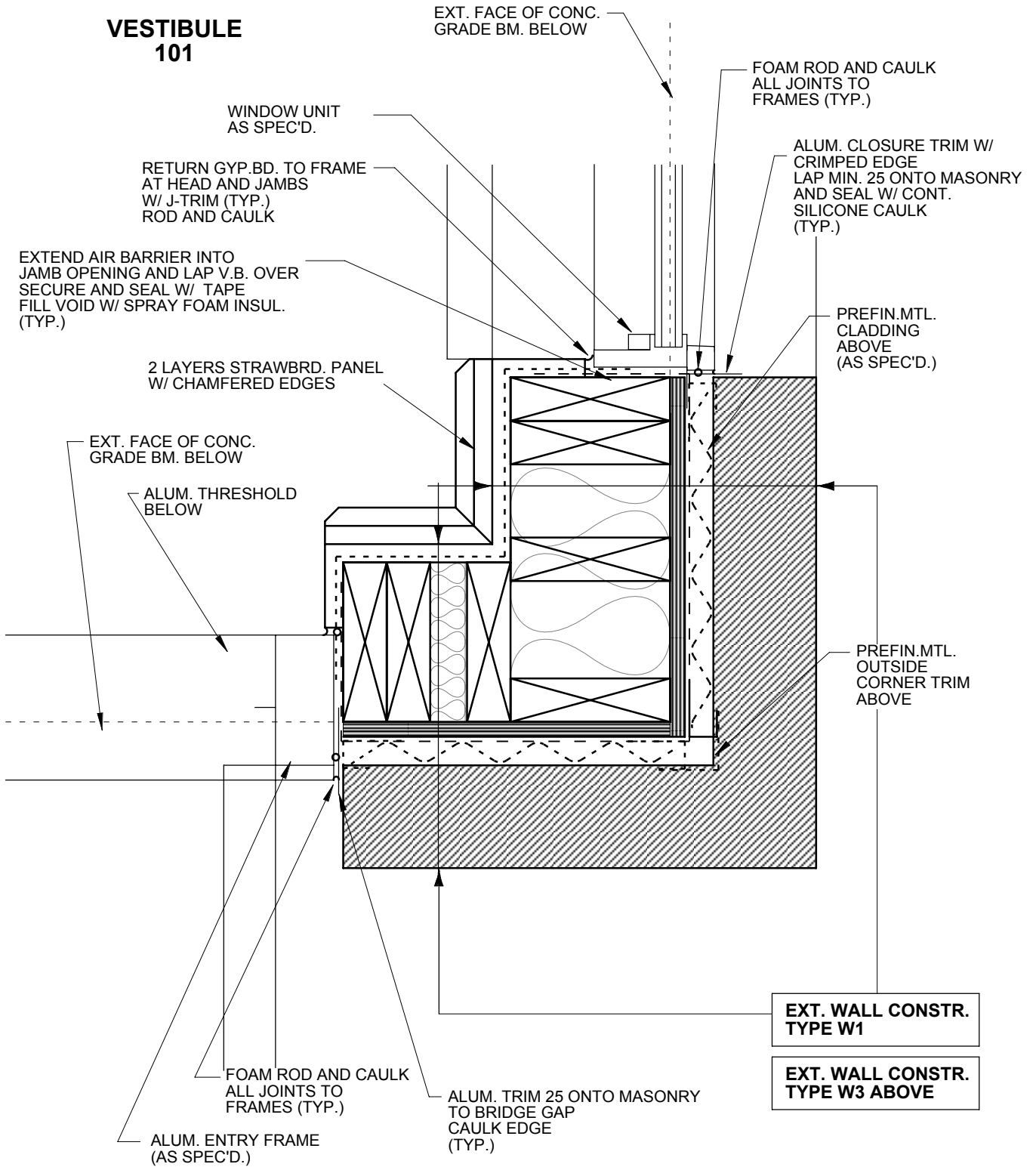

Project Title: RED RIVER COMMUNITY CENTRE
293 MURRAY AVENUE

Sheet Title: PLAN DETAIL @ VEST. 101

200 -141 Bannatyne Avenue East
Winnipeg • Manitoba • R3B 0R3
(204) 956-0938

Proj. No: 2003.06 Rev: R-1

Scale: 1 : 5

Rev: R-1

Date: March 23, 2005

Detail Sheet No.

DA-01

Printing Date:

3/22/05

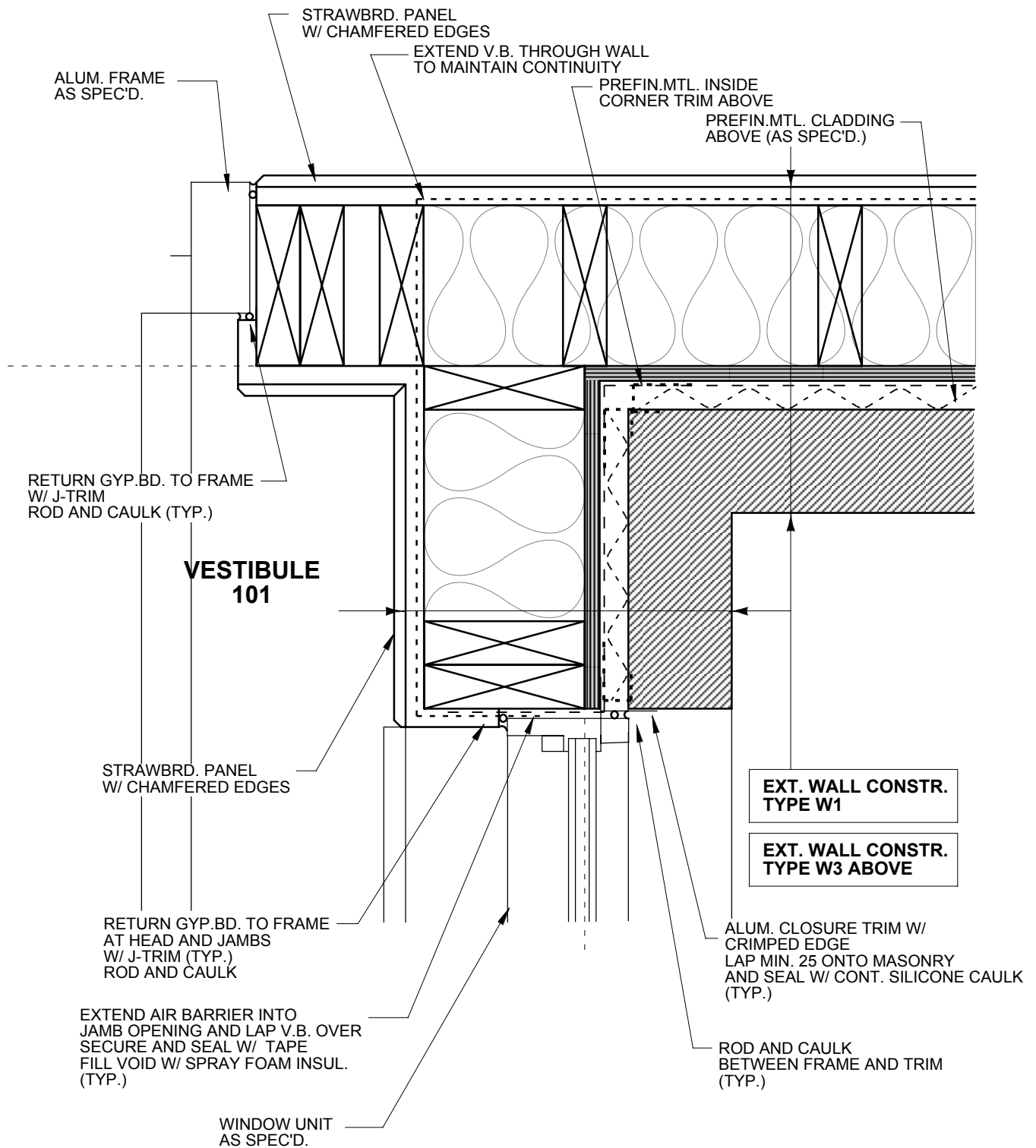

Project Title: RED RIVER COMMUNITY CENTRE
293 MURRAY AVENUE

Sheet Title: **PLAN DETAIL @ VEST. 101**

200 -141 Bannatyne Avenue East
Winnipeg • Manitoba • R3B 0R3
(204) 956-0938

Proj. No: 2003.06 Rev: R-1

Scale: 1 : 5

Date: March 23, 2005

Detail Sheet No. **DA-02**

Printing Date: 3/24/05

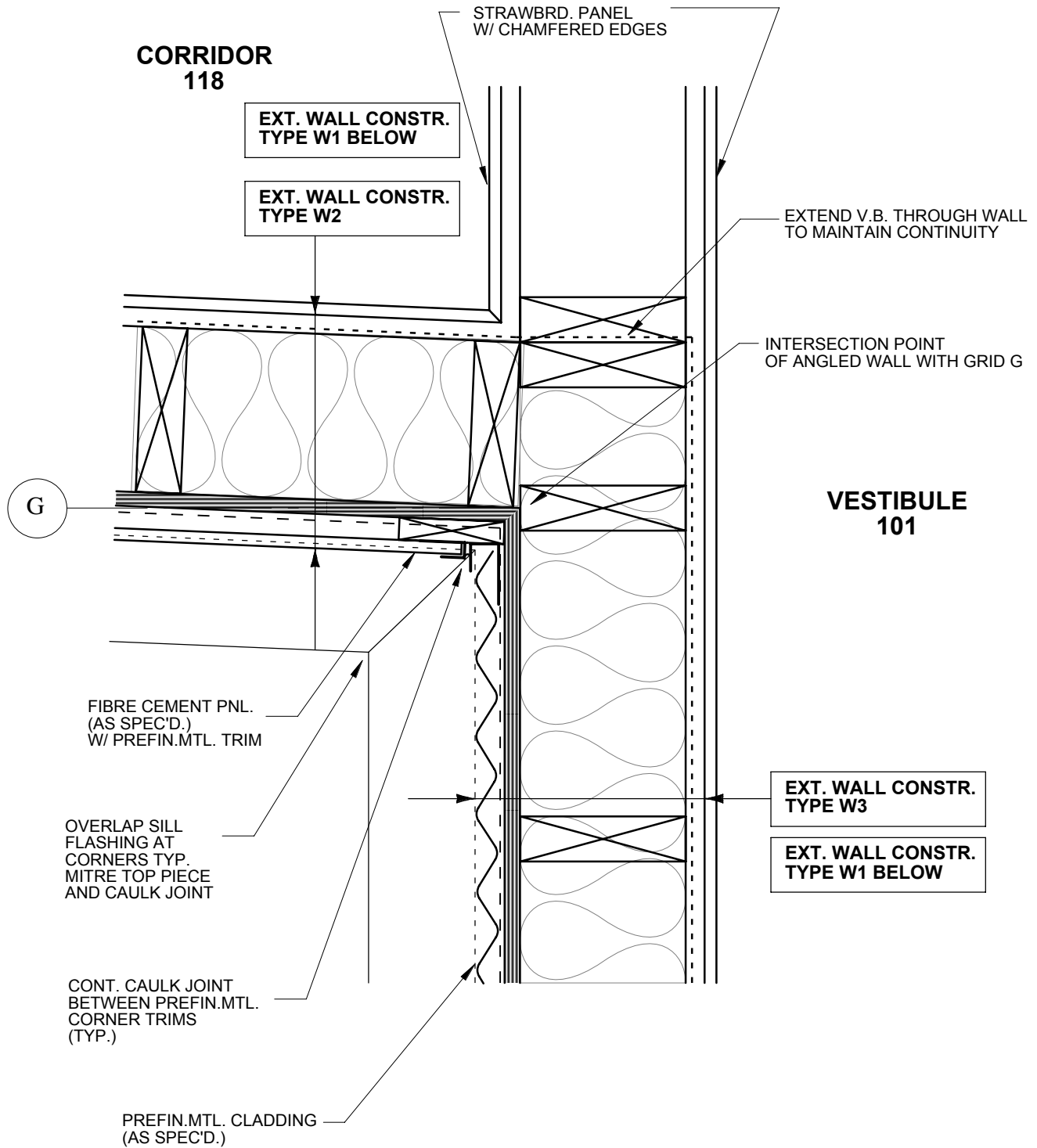

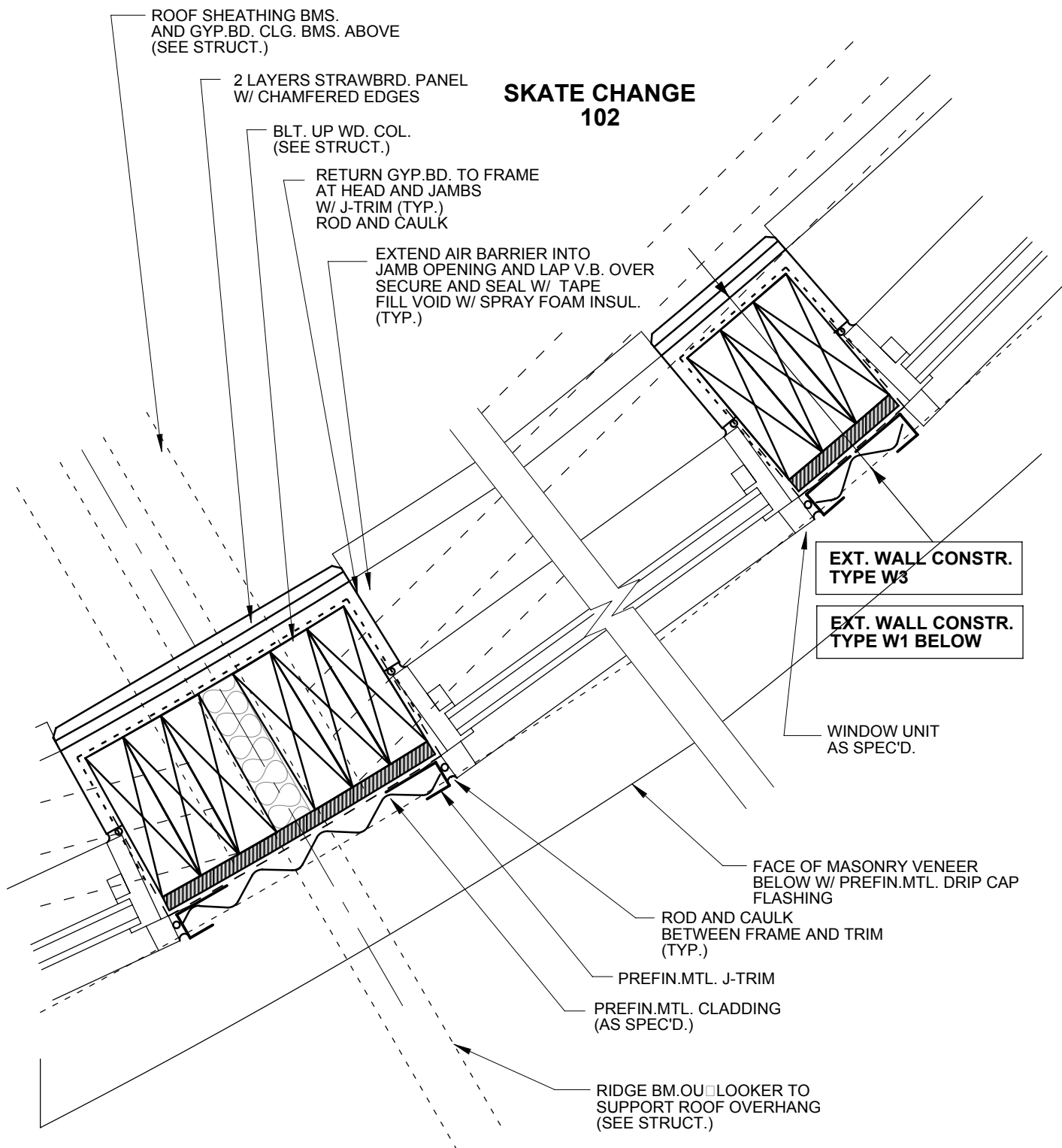

Project Title: RED RIVER COMMUNITY CENTRE
293 MURRAY AVENUE

Sheet Title: **JAMB DETAIL @ SKATE CHANGE 102**

200 -141 Bannatyne Avenue East
Winnipeg • Manitoba • R3B 0R3
(204) 956-0938

Proj. No: 2003.06 Rev: R-1

Scale: 1 : 5

Rev: R-1

Date: March 23, 2005

Detail Sheet No.

DA-04

Printing Date:

3/24/05

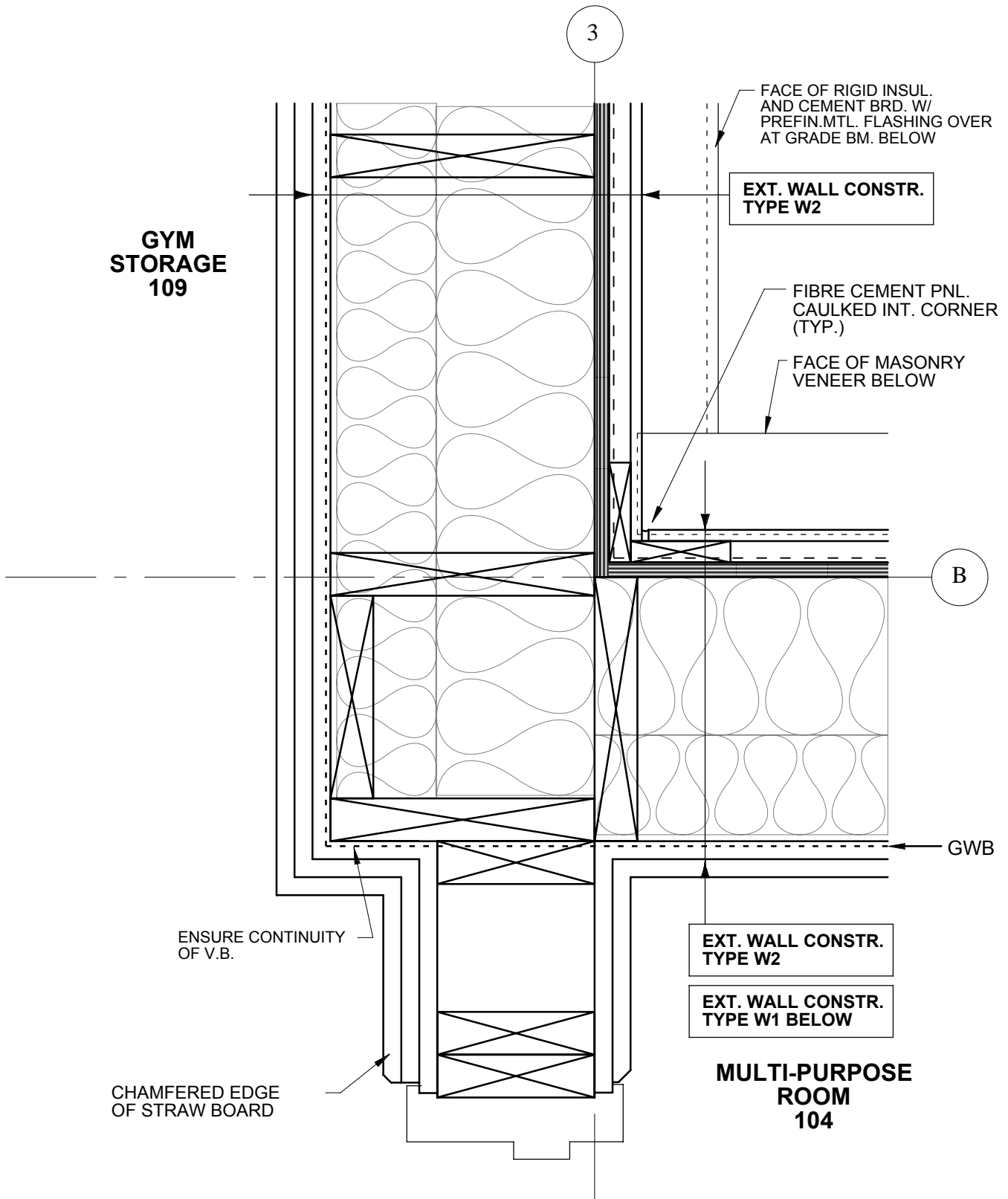

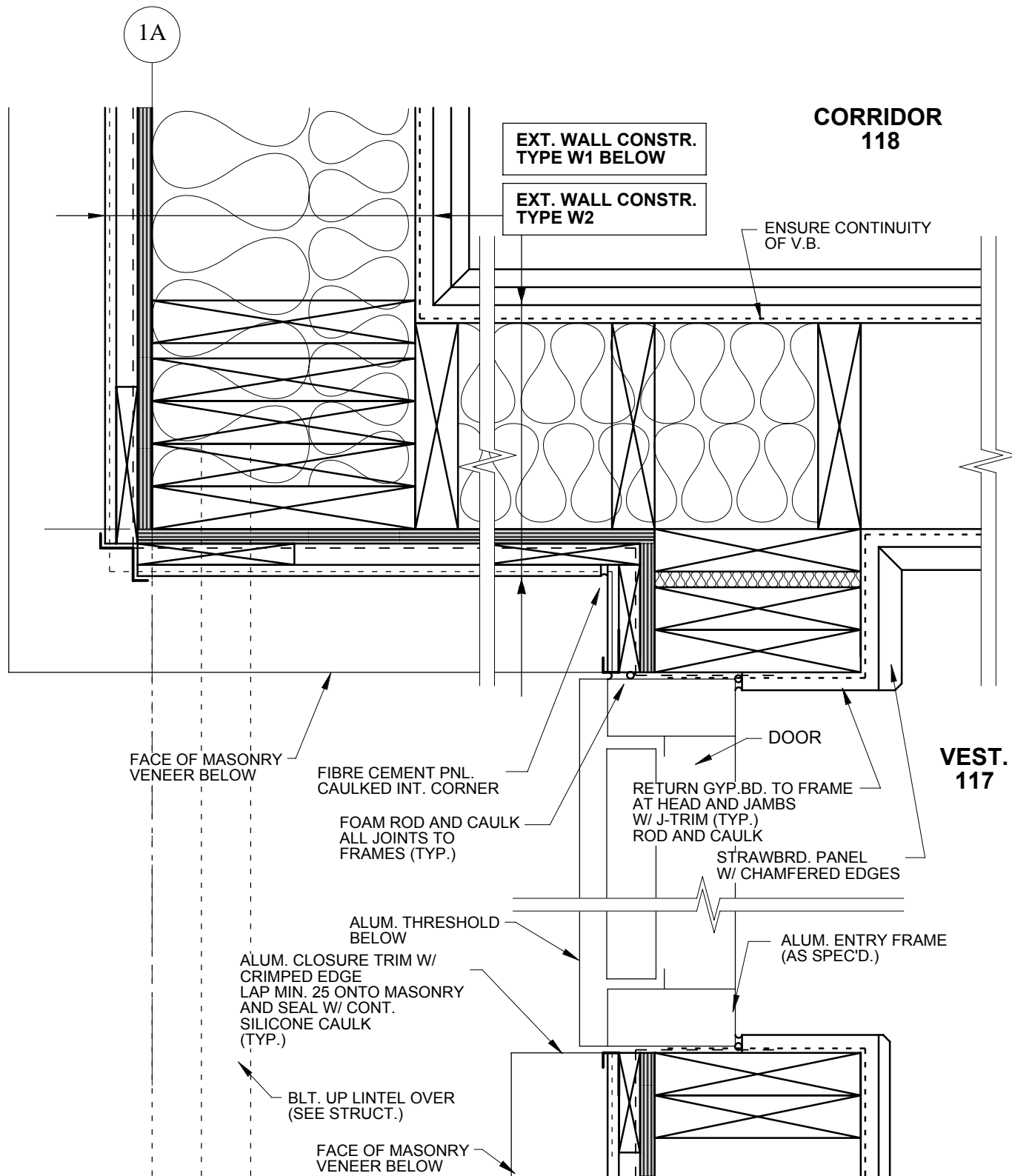

PRAIRIE
ARCHITECTS INC.

Project Title: RED RIVER COMMUNITY CENTRE
293 MURRAY AVENUE

Sheet Title: **PLAN DETAIL @ GRID 1 AND F**

200 -141 Bannatyne Avenue East
Winnipeg • Manitoba • R3B 0R3
(204) 956-0938

Proj. No: 2003.06 Rev: R-1

Scale: 1 : 5

Rev: R-1

Date: **March 23, 2005** Detail Sheet No. **DA-06**

Printing Date: 3/24/05

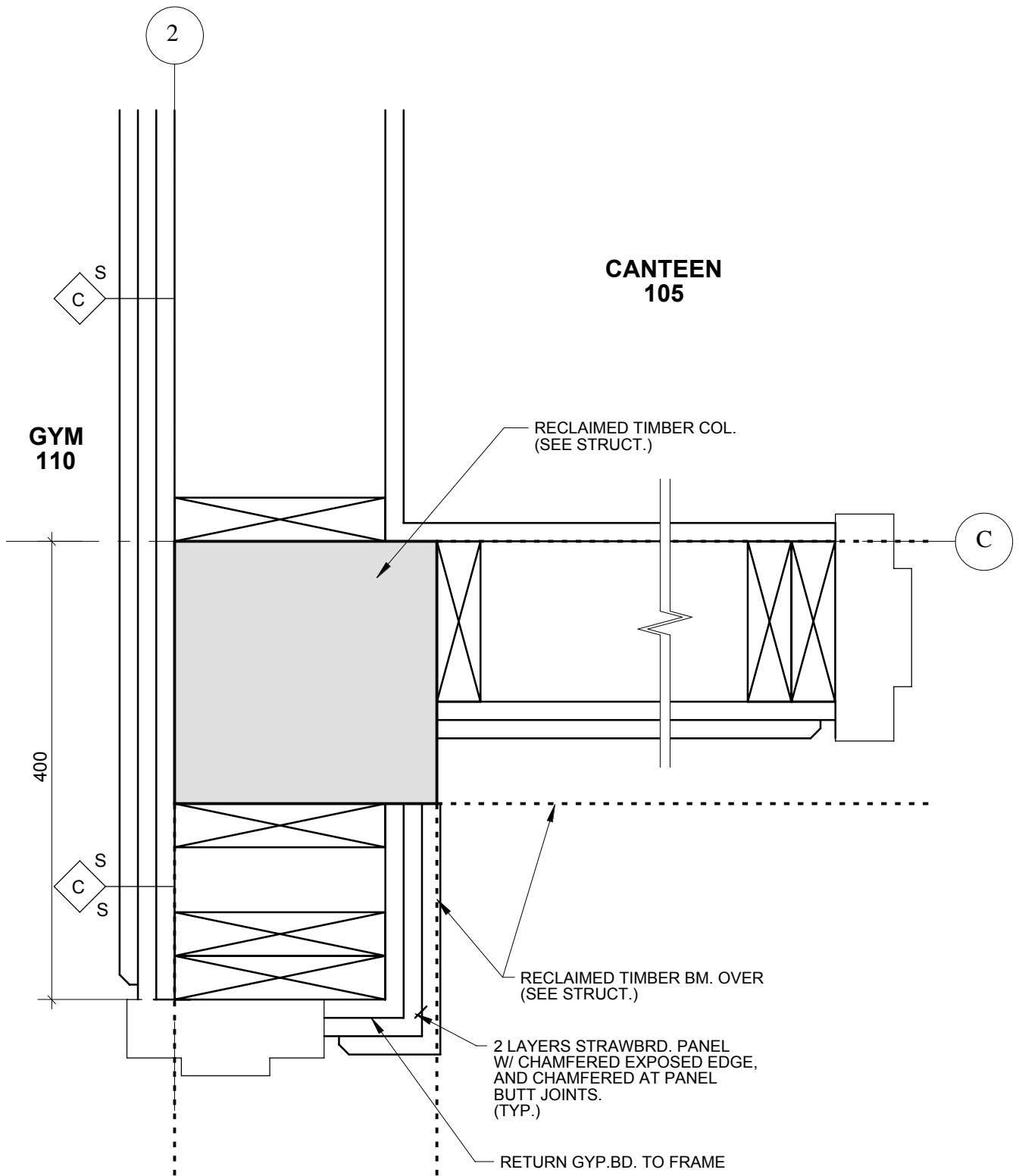

PRAIRIE
ARCHITECTS INC.

Project Title: RED RIVER COMMUNITY CENTRE
293 MURRAY AVENUE

Sheet Title: **PLAN DETAIL @ GRID 2 AND C**

200 -141 Bannatyne Avenue East
Winnipeg • Manitoba • R3B 0R3
(204) 956-0938

Proj. No: 2003.06 Rev: R-1

Scale: 1 : 5

Date: March 23, 2005

Detail Sheet No.

DA-07

Printing Date: 3/22/05

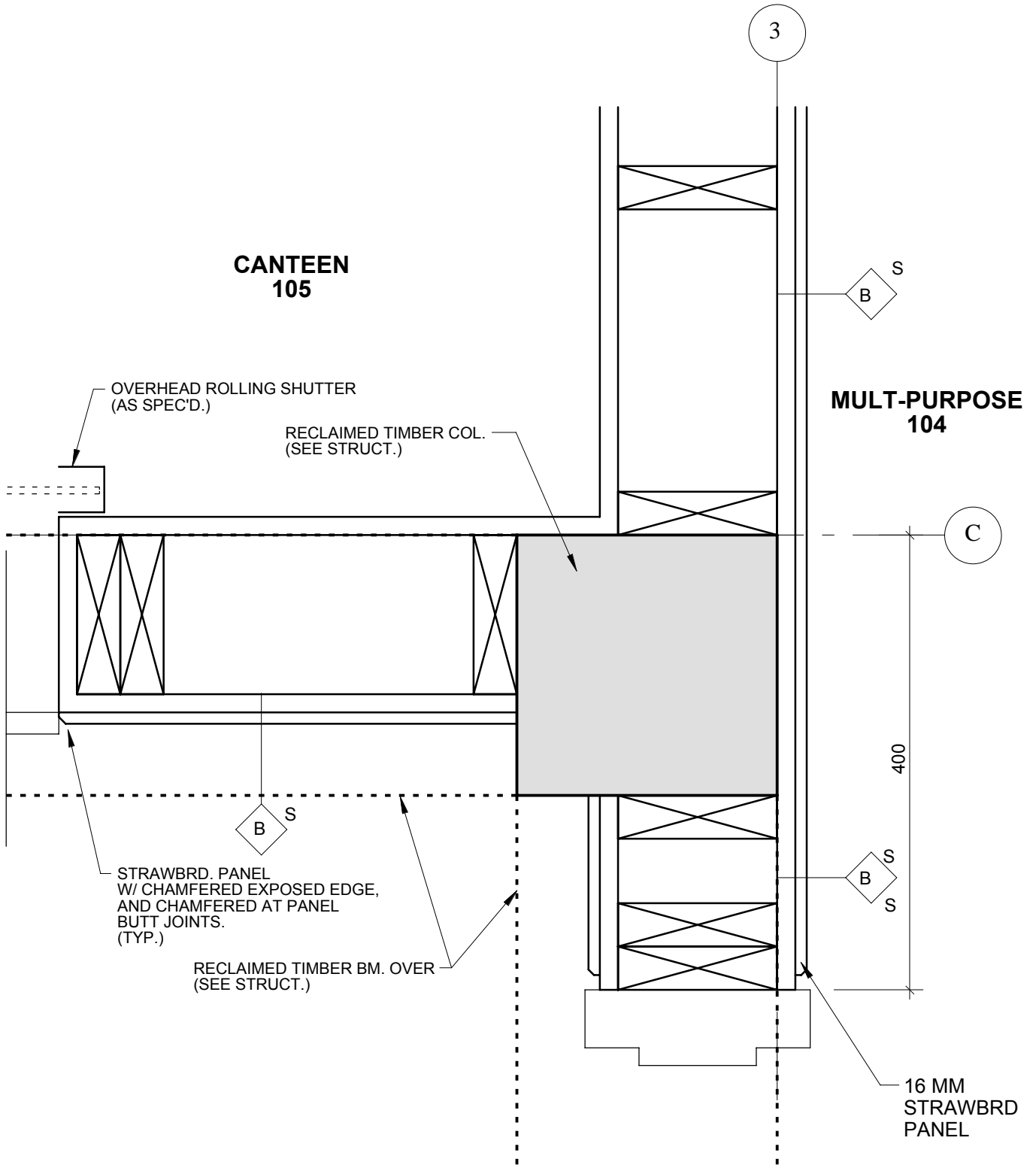

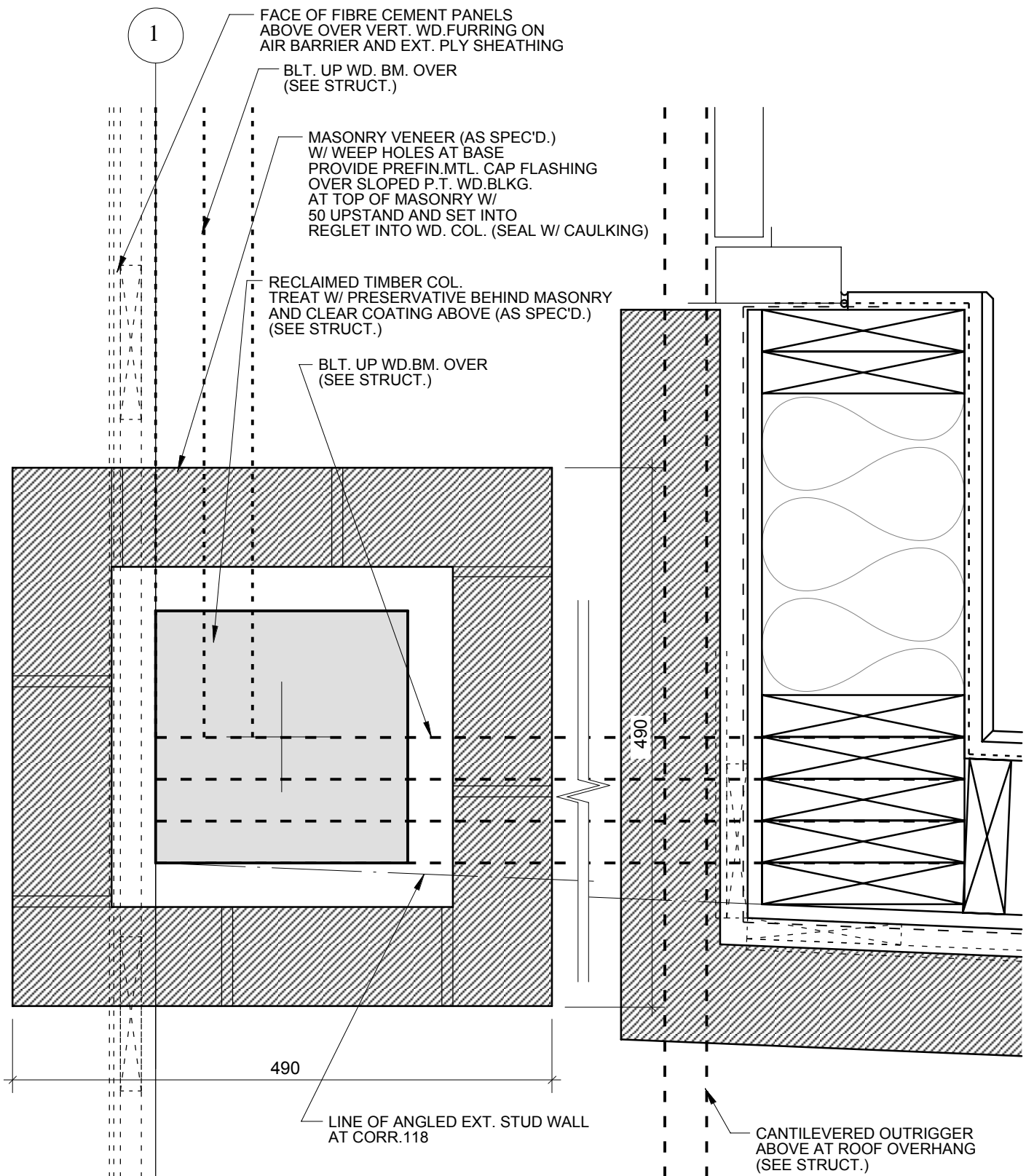

Project Title: RED RIVER COMMUNITY CENTRE
293 MURRAY AVENUE

Sheet Title: **PLAN DETAIL @ GRID 1 AND G**

200 -141 Bannatyne Avenue East
Winnipeg • Manitoba • R3B 0R3
(204) 956-0938

Proj. No: 2003.06 Rev: R-1

Scale: 1 : 5

Date: **March 23, 2005** Detail Sheet No. **DA-09**

Printing Date: 3/24/05

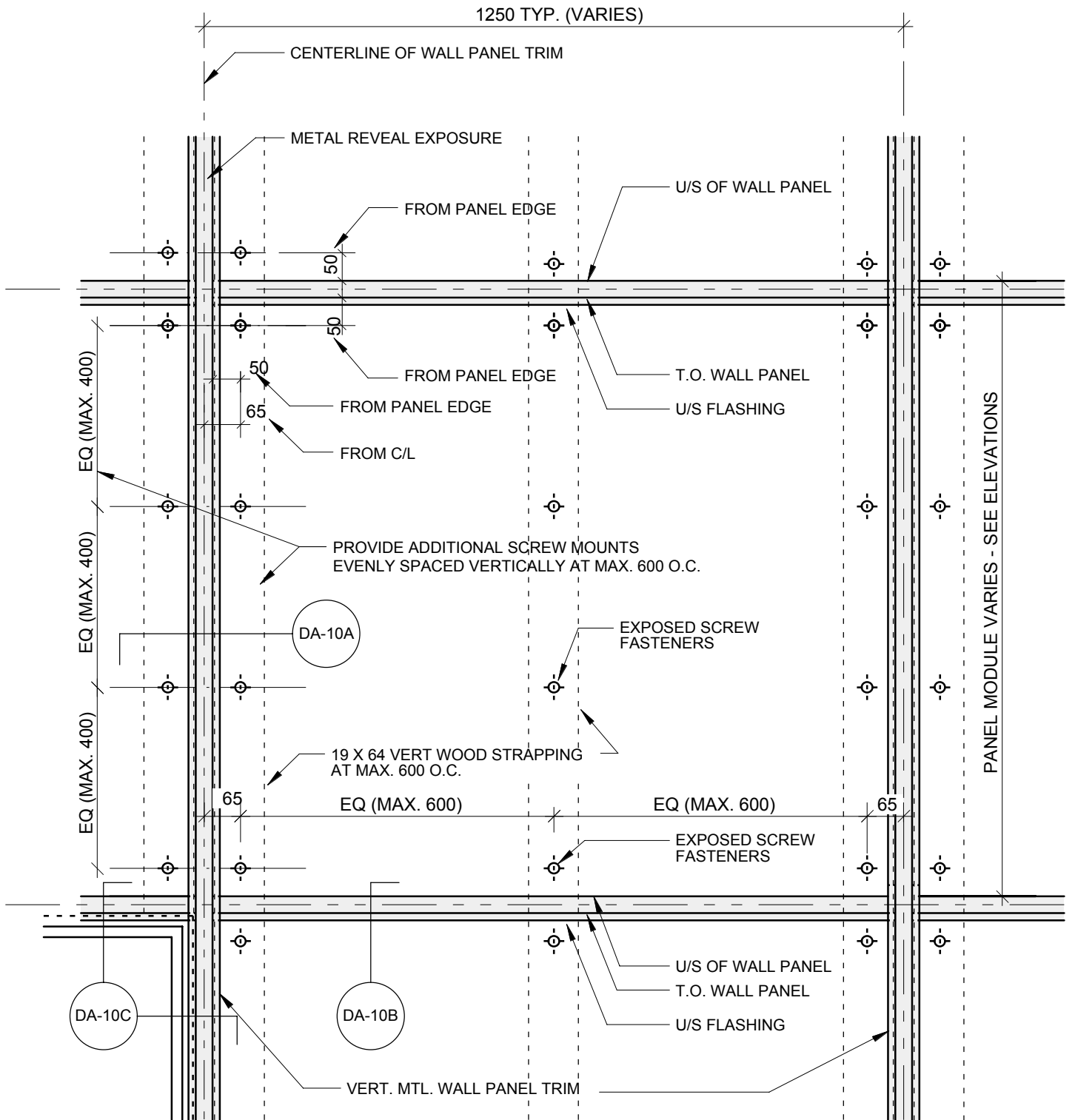

NOTE: CONFIRM FASTENER SPACING W/
PANEL SUPPLIER

NOTE: SEE OTHER DETAILS FOR SPECIAL
TRIM CONDITIONS



Project Title: RED RIVER COMMUNITY CENTRE
293 MURRAY AVENUE
Sheet Title: **TYPICAL EXTERIOR PANEL ELEVATION**

200 -141 Bannatyne Avenue East
Winnipeg • Manitoba • R3B 0R3
(204) 956-0938

Proj. No: 2003.06 Rev: R-1
Scale: 1 : 10 Date: March 23, 2005 Detail Sheet No. **DA-10**

Printing Date: 3/24/05

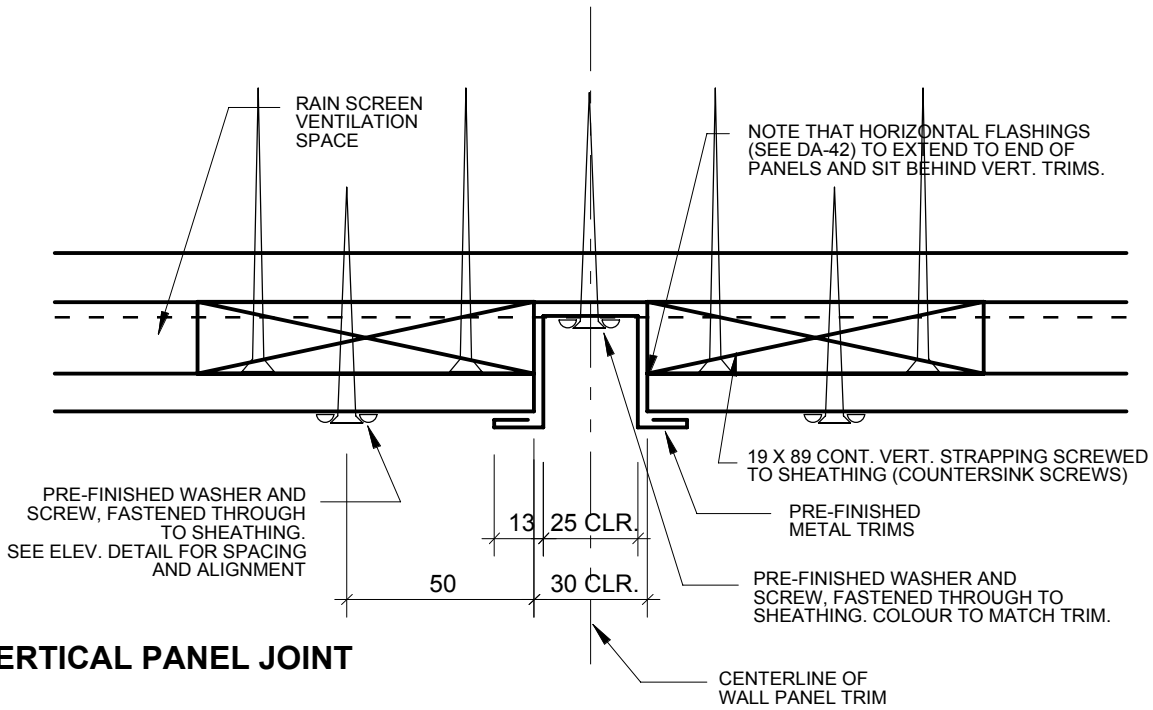

VERTICAL PANEL JOINT

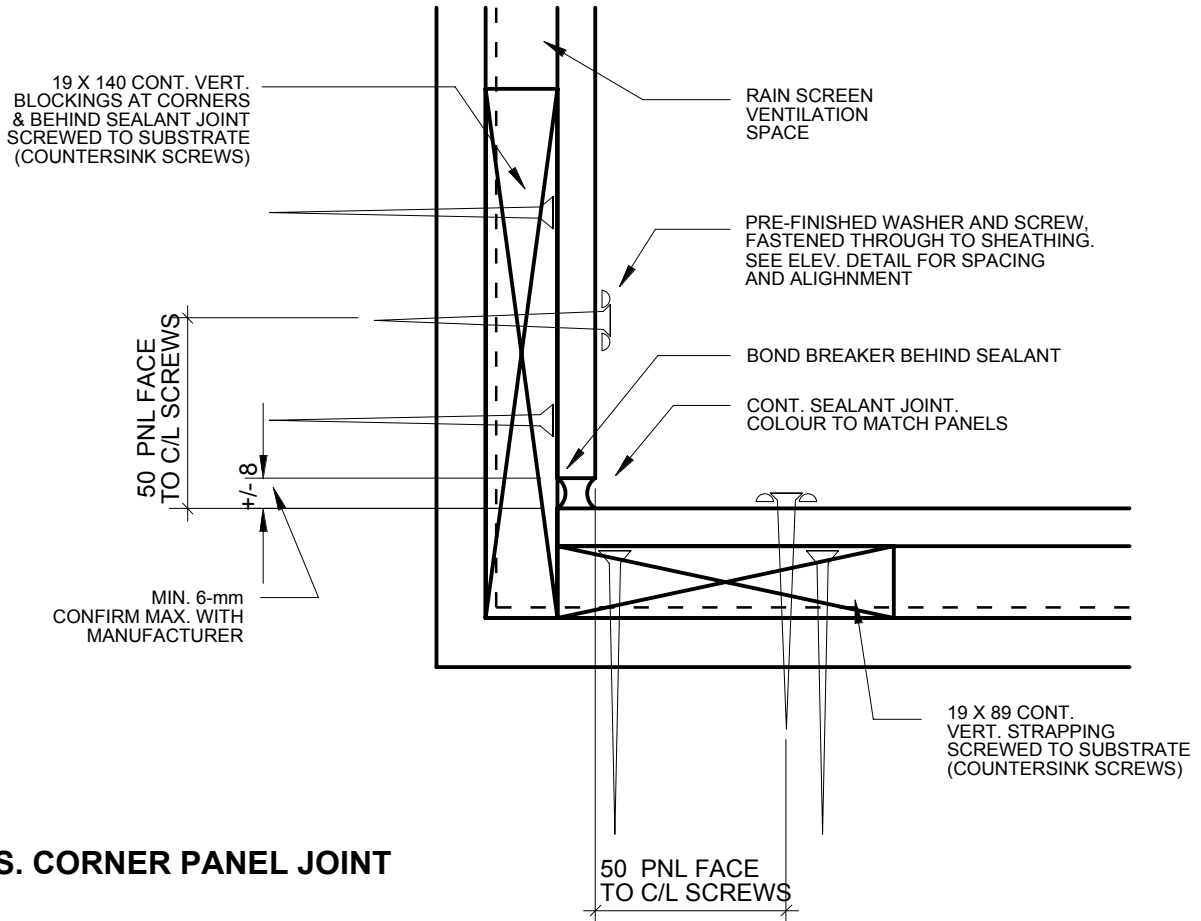

I.S. CORNER PANEL JOINT



200 -141 Bannatyne Avenue East
 Winnipeg • Manitoba • R3B 0R3
 (204) 956-0938

Project Title: RED RIVER COMMUNITY CENTRE
 293 MURRAY AVENUE

Sheet Title: **TYPICAL EXTERIOR PANEL -
 VERTICAL AND INSIDE CORNER DETAIL**

Proj. No: 2003.06 Rev: R-1

Scale: 1 : 2

Date: **March 23, 2005**

Detail Sheet No. **DA-10A**

Printing Date: 3/17/05

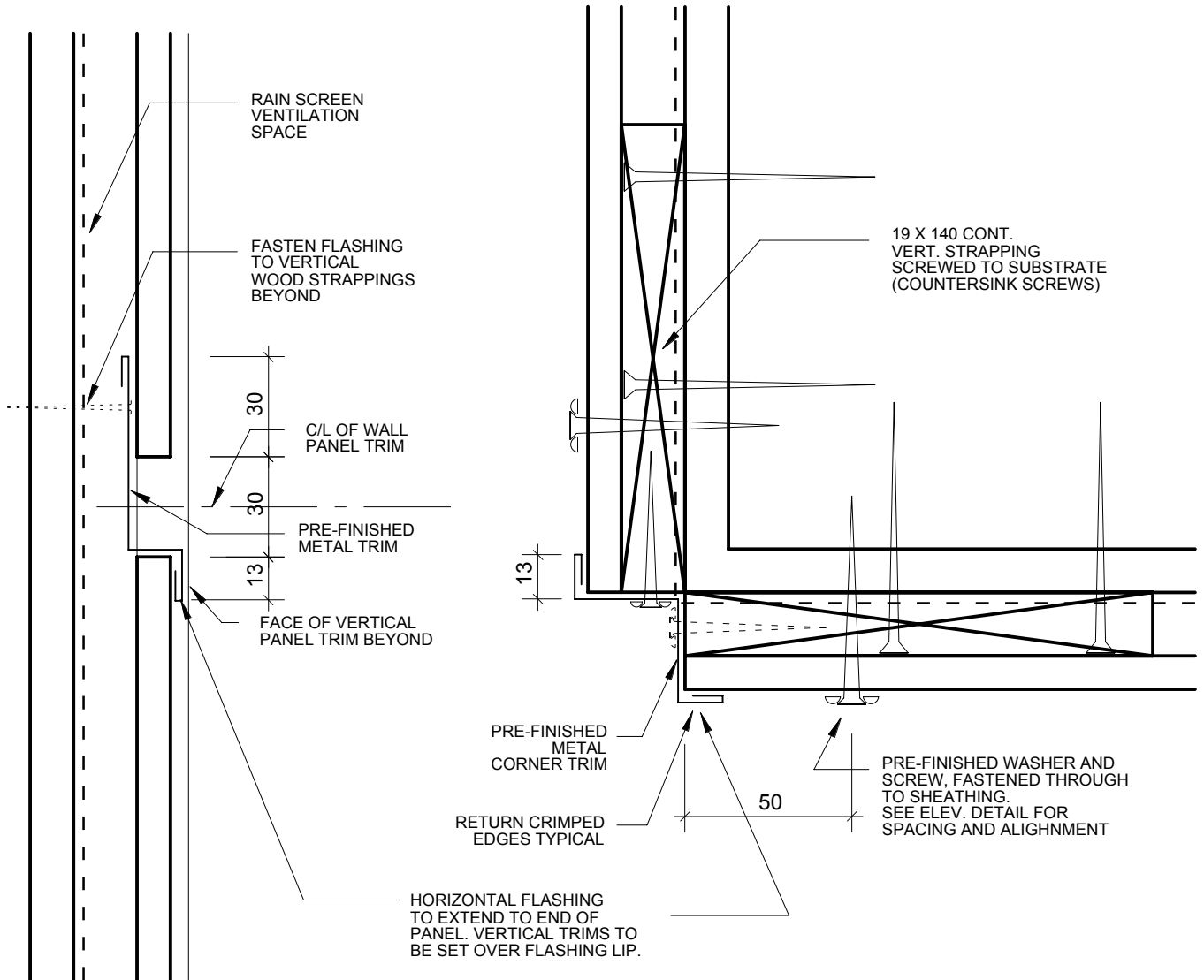

**HORIZONTAL PANEL JOINT
(SECTIONAL DETAIL)**

**O.S. CORNER PANEL JOINT
(PLAN DETAIL)**



200 -141 Bannatyne Avenue East
Winnipeg • Manitoba • R3B 0R3
(204) 956-0938

Project Title: RED RIVER COMMUNITY CENTRE
293 MURRAY AVENUE

Sheet Title: **TYPICAL EXTERIOR PANEL - HORIZONTAL
AND OUTSIDE CORNER DETAIL**

Proj. No: 2003.06 Rev: R-1

Scale: 1 : 2

Date: March 23, 2005

Detail Sheet No.

DA-10B

Printing Date: 9/16/04

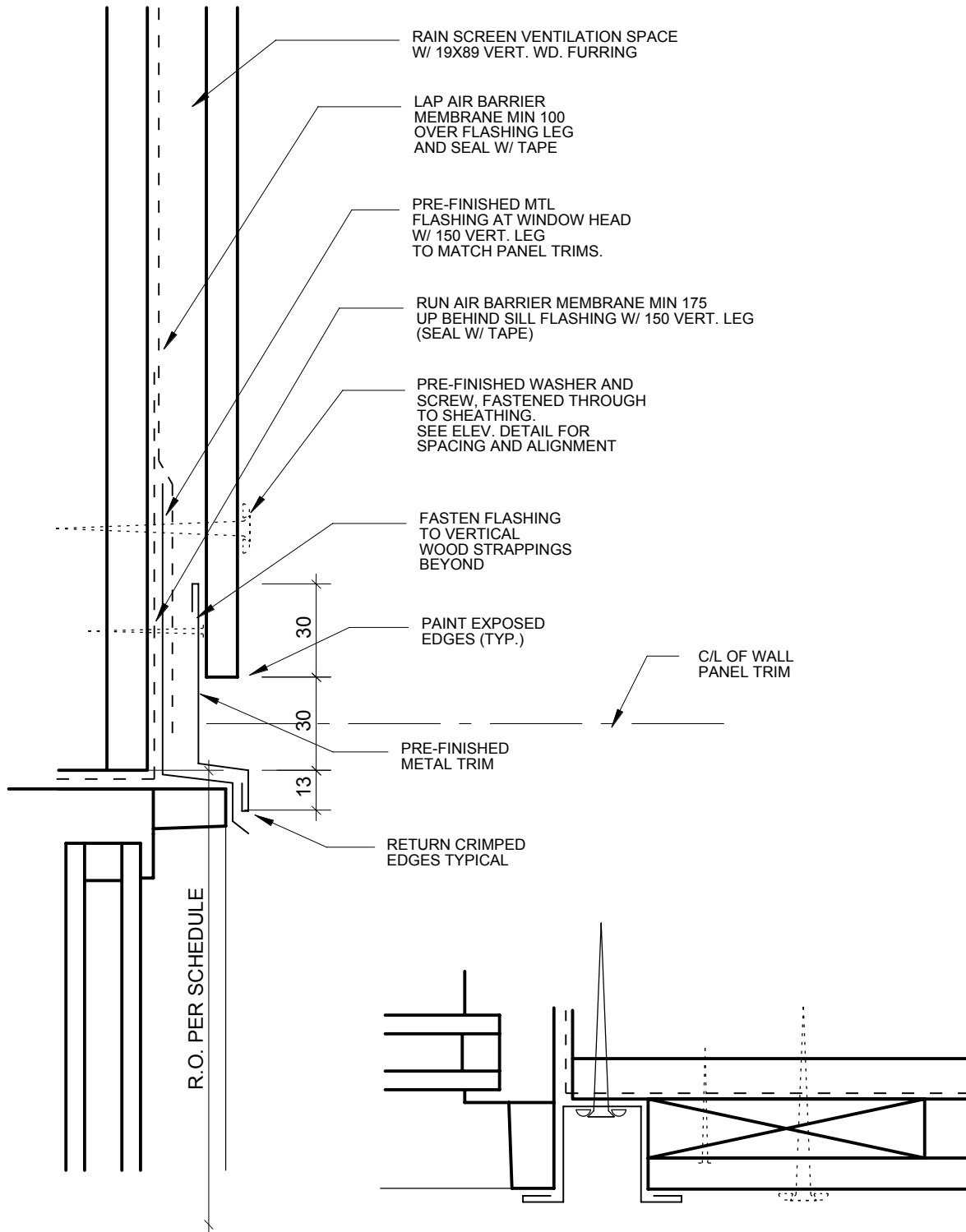

**HORIZONTAL PANEL JOINT
(SECTIONAL DETAIL)
AT WINDOW HEADS**

**HORIZONTAL PANEL JOINT
(PLAN DETAIL)
AT WINDOW JAMBS**



200 -141 Bannatyne Avenue East
Winnipeg • Manitoba • R3B 0R3
(204) 956-0938

Project Title: RED RIVER COMMUNITY CENTRE
293 MURRAY AVENUE

Sheet Title: **TYPICAL EXTERIOR PANEL - AT
WINDOW HEADS AND JAMBS**

Proj. No: 2003.06 Rev: R-1

Scale: 1 : 2

Date: March 23, 2005

Detail Sheet No.

DA-10C

Printing Date: 12/20/04

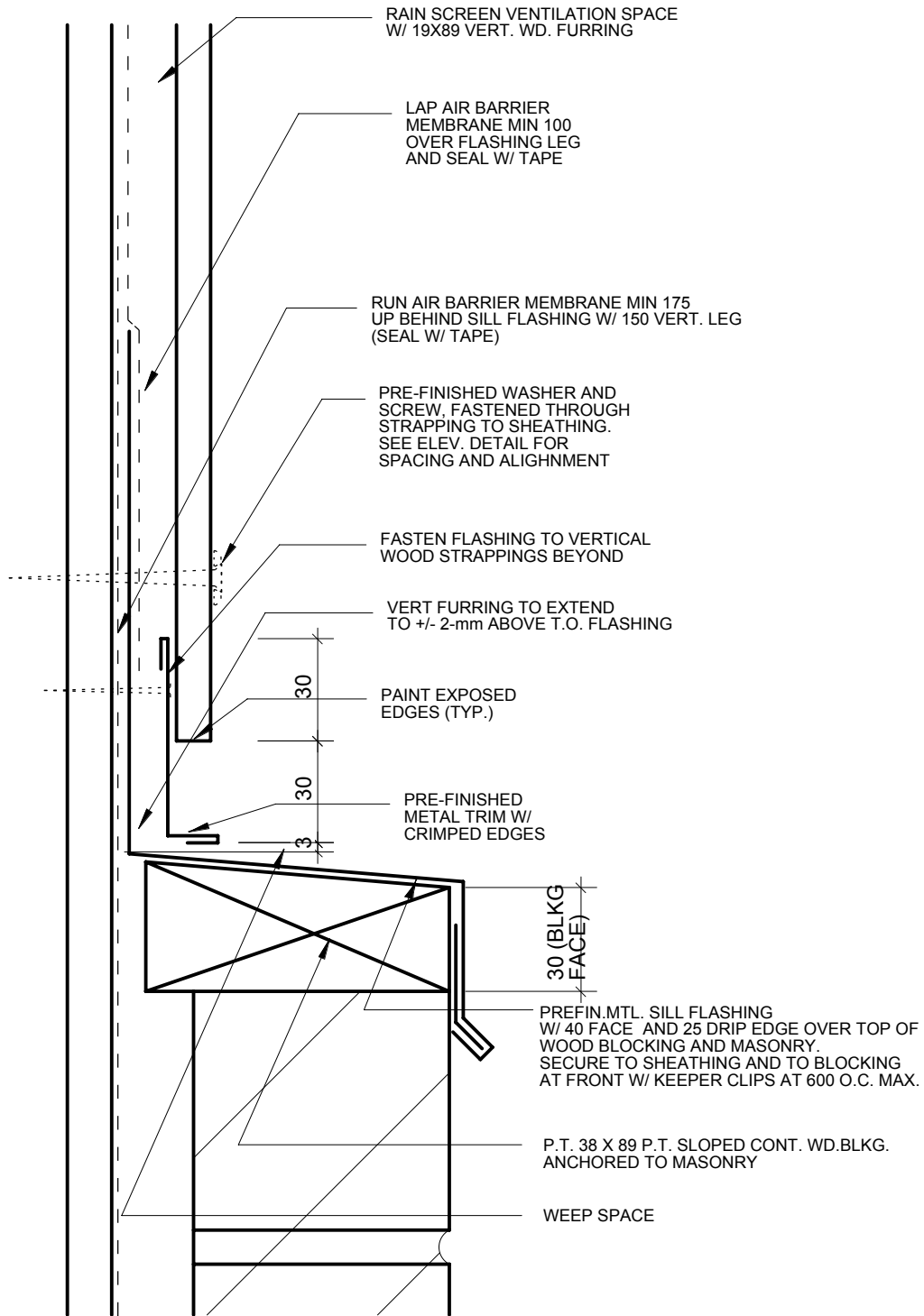

**HORIZONTAL PANEL JOINT
(SECTIONAL DETAIL)
AT T.O. MASONRY**



200 -141 Bannatyne Avenue East
Winnipeg • Manitoba • R3B 0R3
(204) 956-0938

Project Title: RED RIVER COMMUNITY CENTRE
293 MURRAY AVENUE

Sheet Title: **TYPICAL EXTERIOR PANEL - AT
MASONRY AND PANEL CONNECTION**

Proj. No: 2003.06 Rev: R-1

Scale: 1 : 2

Date: March 23, 2005

Detail Sheet No. **DA-10D**

Printing Date: 3/17/05

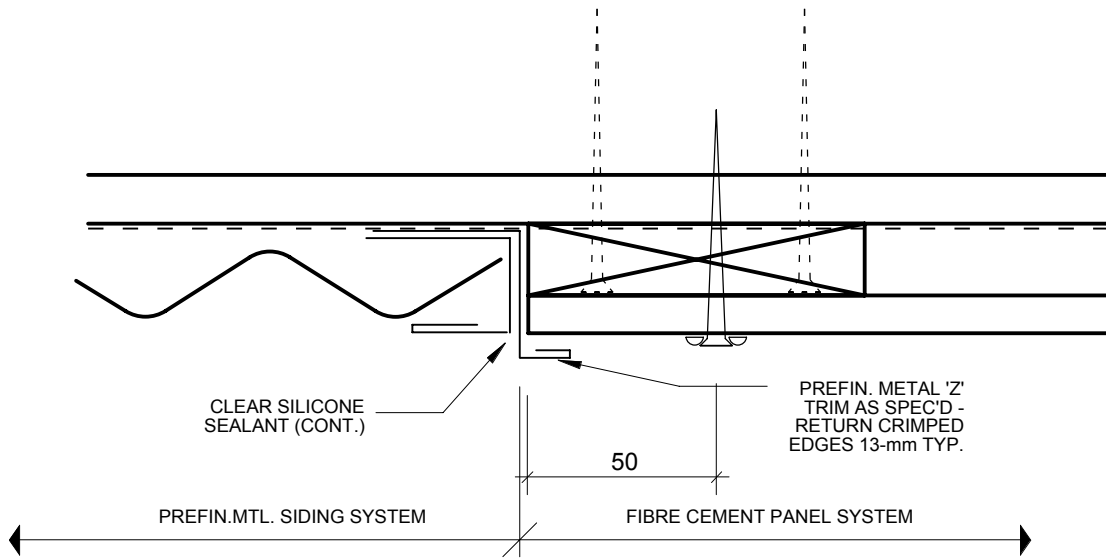

PLAN DETAIL - AT PANELS TO MTL. SIDING

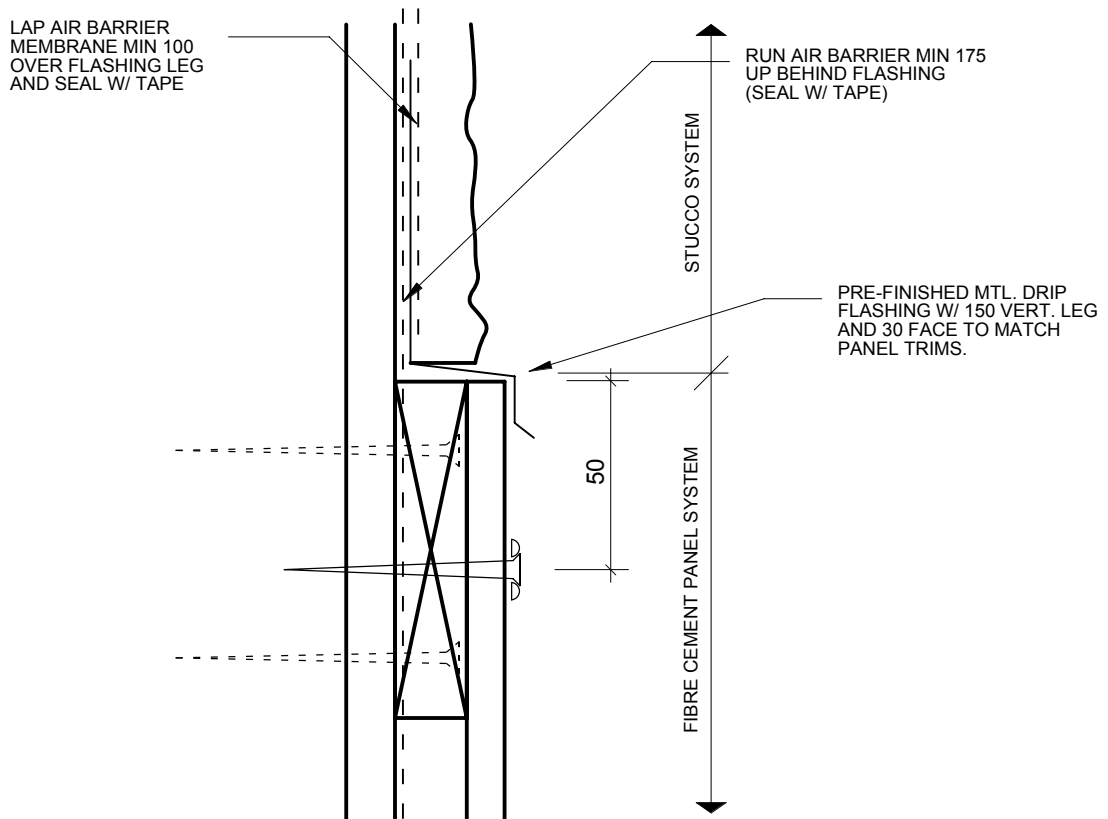

SECTION DETAIL - AT PANELS TO STUCCO

PRAIRIE
ARCHITECTS INC.

Project Title: RED RIVER COMMUNITY CENTRE
293 MURRAY AVENUE

Sheet Title: **TYPICAL EXT. PANEL - AT STUCCO AND METAL SIDING CONNECTION**

200 -141 Bannatyne Avenue East
Winnipeg • Manitoba • R3B 0R3
(204) 956-0938

Proj. No: 2003.06 Rev: R-1

Scale: 1 : 2 Date: **March 23, 2005**

Detail Sheet No. **DA-10E**

Printing Date: 3/17/05

**VESTIBULE
101**

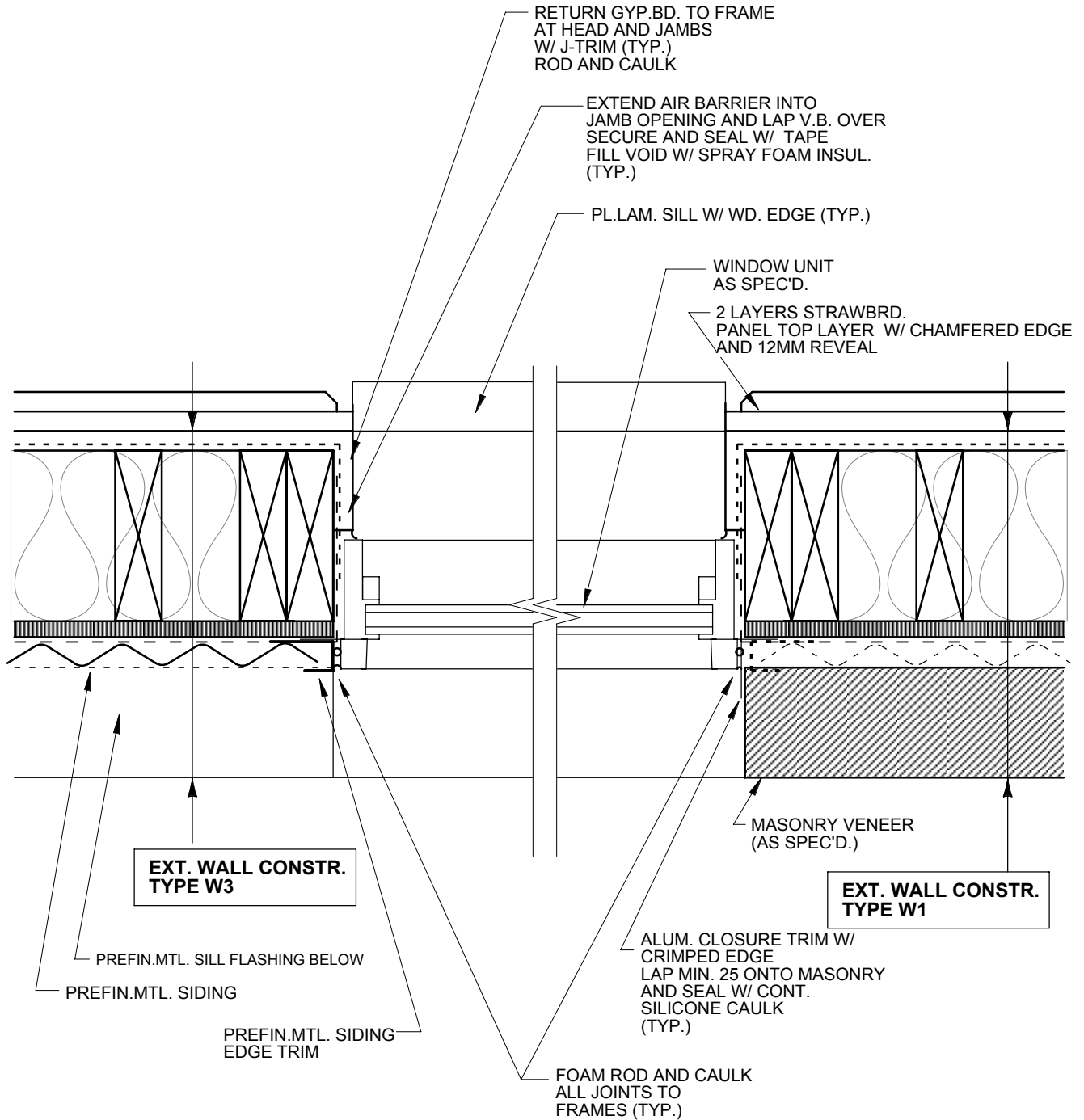

Project Title: **RED RIVER COMMUNITY CENTRE
293 MURRAY AVENUE**
 Sheet Title: **PLAN DETAIL - TYPICAL WINDOW JAMB**

200 -141 Bannatyne Avenue East
 Winnipeg • Manitoba • R3B 0R3
 (204) 956-0938

Proj. No: 2003.06 Rev: R-1
 Scale: 1 : 5 Date: **March 23, 2005** Detail Sheet No. **DA-11**

Printing Date: 3/22/05

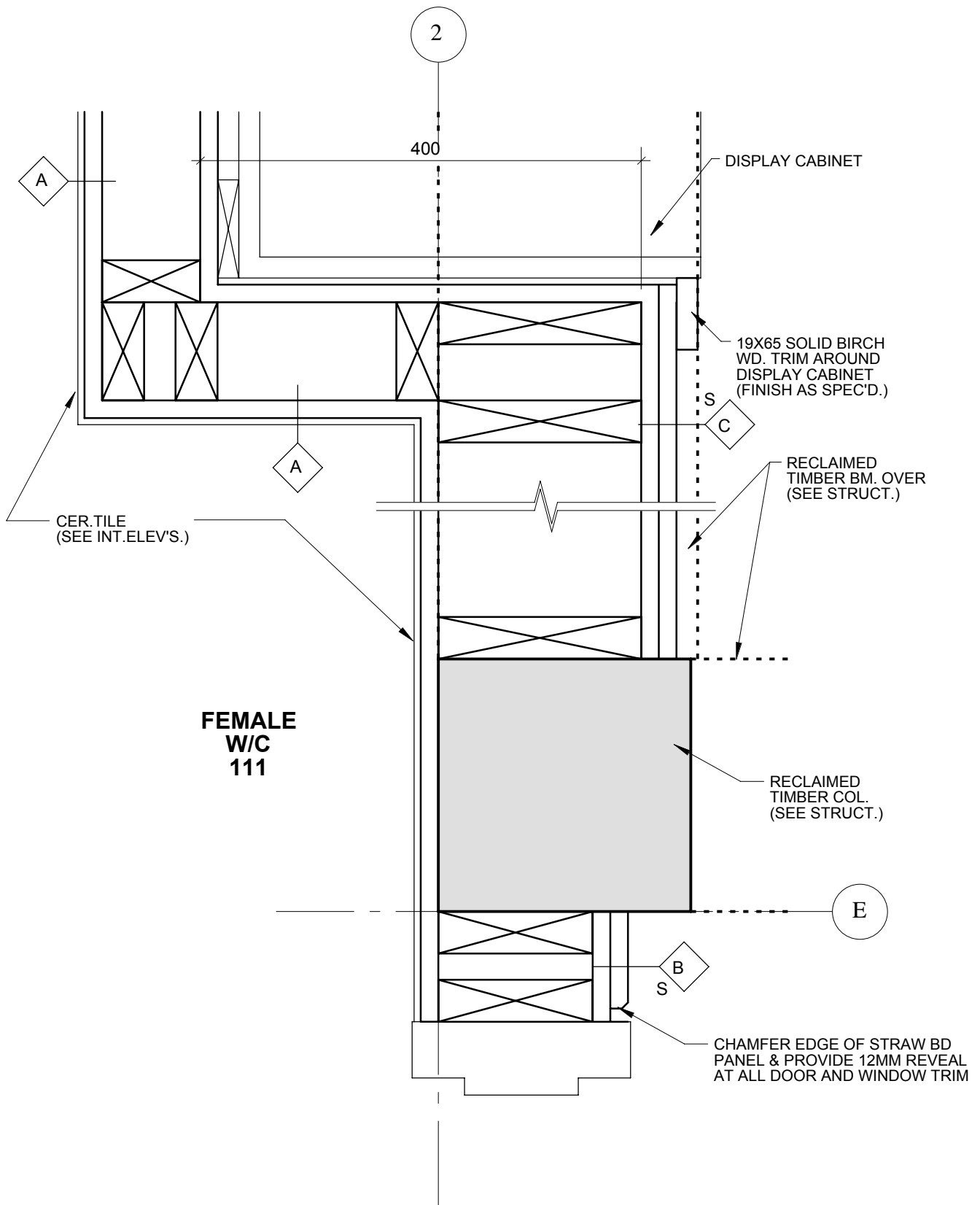

2

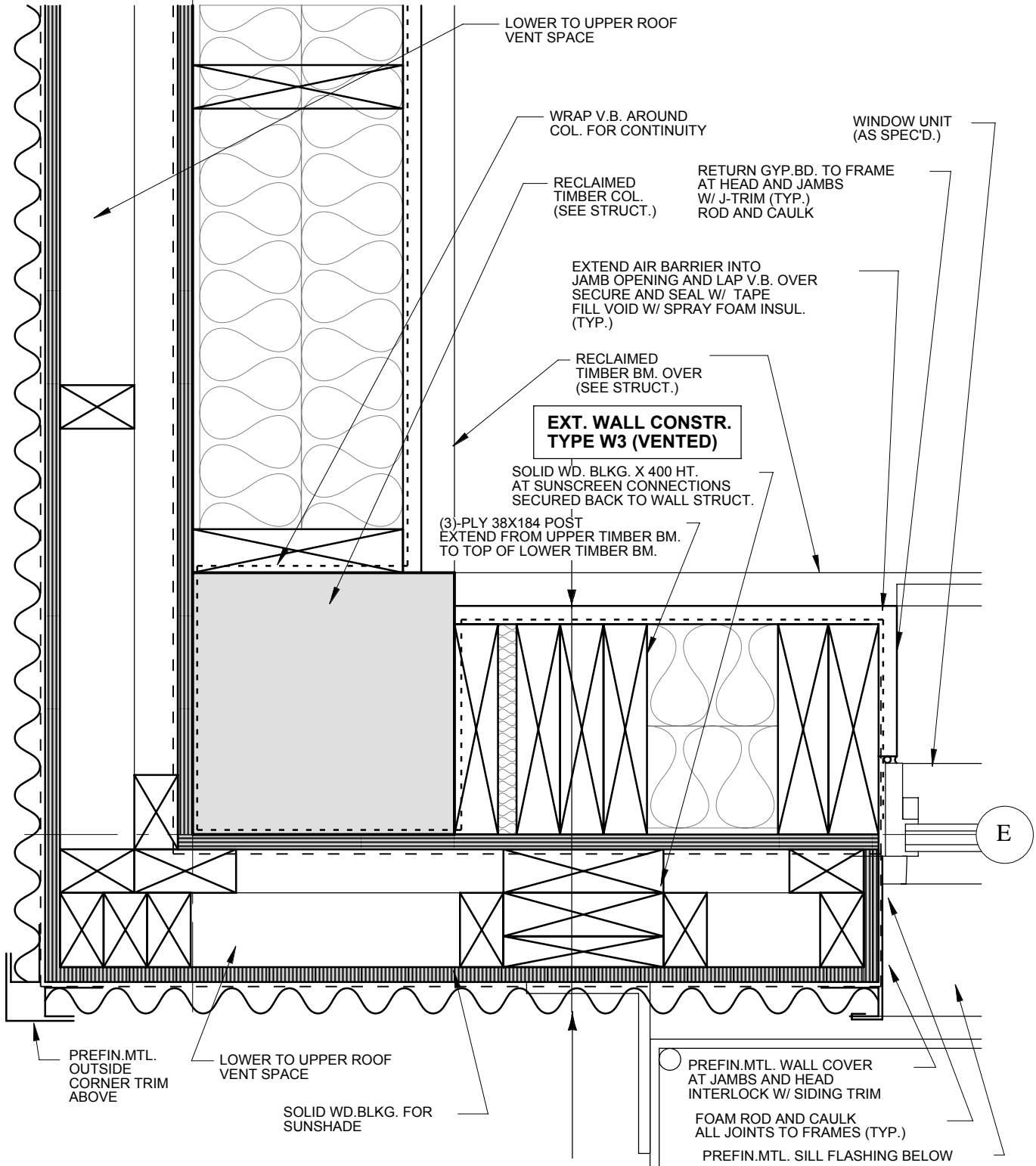

Project Title: RED RIVER COMMUNITY CENTRE
293 MURRAY AVENUE

Sheet Title: PLAN DETAIL @ GRID 2 AND E (AT ROOF)

200 -141 Bannatyne Avenue East
Winnipeg • Manitoba • R3B 0R3
(204) 956-0938

Proj. No: 2003.06 Rev: R-1
Scale: 1 : 5 Date: March 23, 2005

Detail Sheet No. **DA-13**

Printing Date: 3/24/05

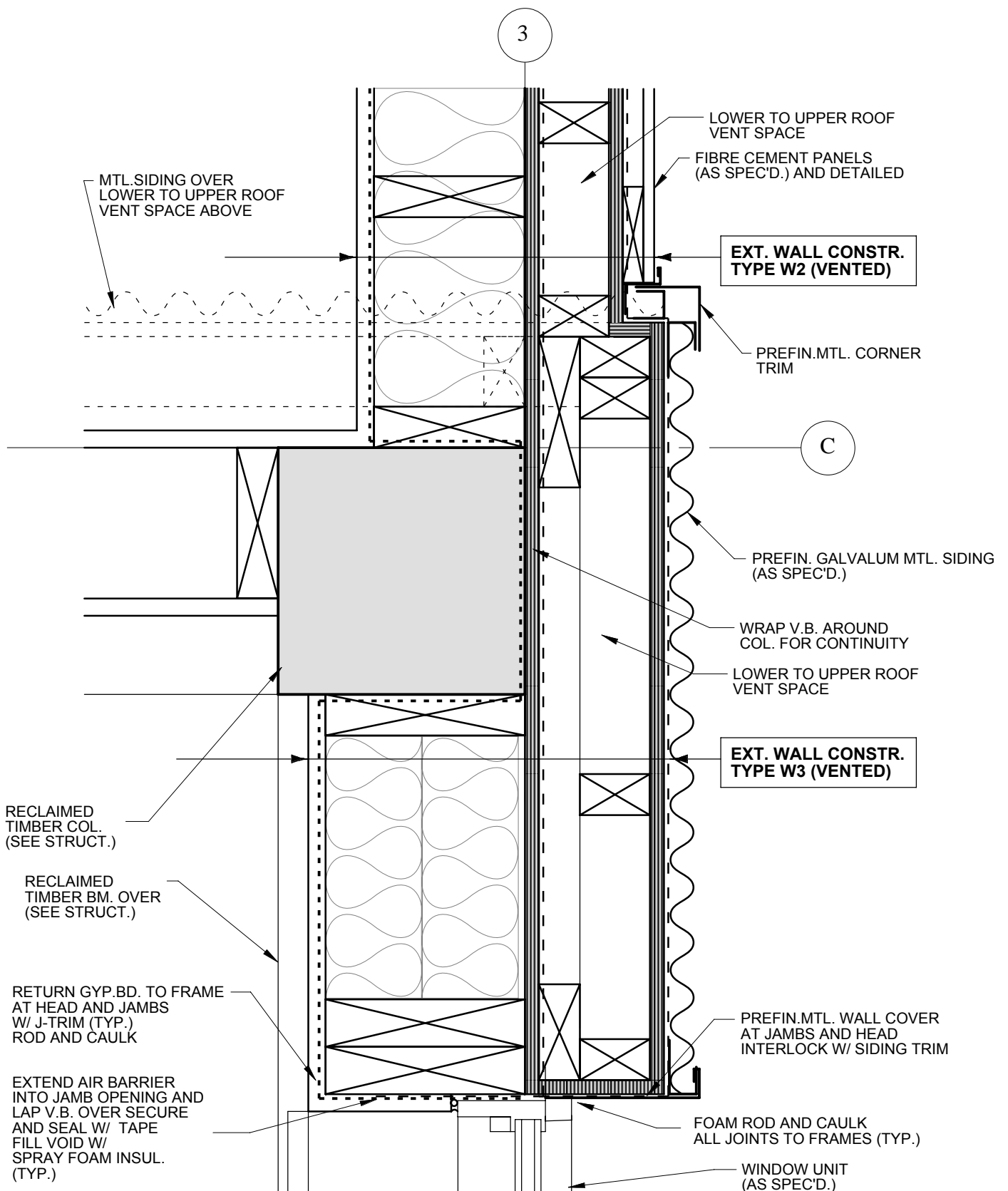

PRAIRIE
ARCHITECTS INC.

Project Title: RED RIVER COMMUNITY CENTRE
293 MURRAY AVENUE

Sheet Title: PLAN DETAIL @ GRID 3 AND C (AT ROOF)

200 -141 Bannatyne Avenue East
Winnipeg • Manitoba • R3B 0R3
(204) 956-0938

Proj. No: 2003.06 Rev: R-1

Scale: 1 : 5

Rev: R-1

Date: March 23, 2005

Detail Sheet No. **DA-14**

Printing Date: 12/20/04

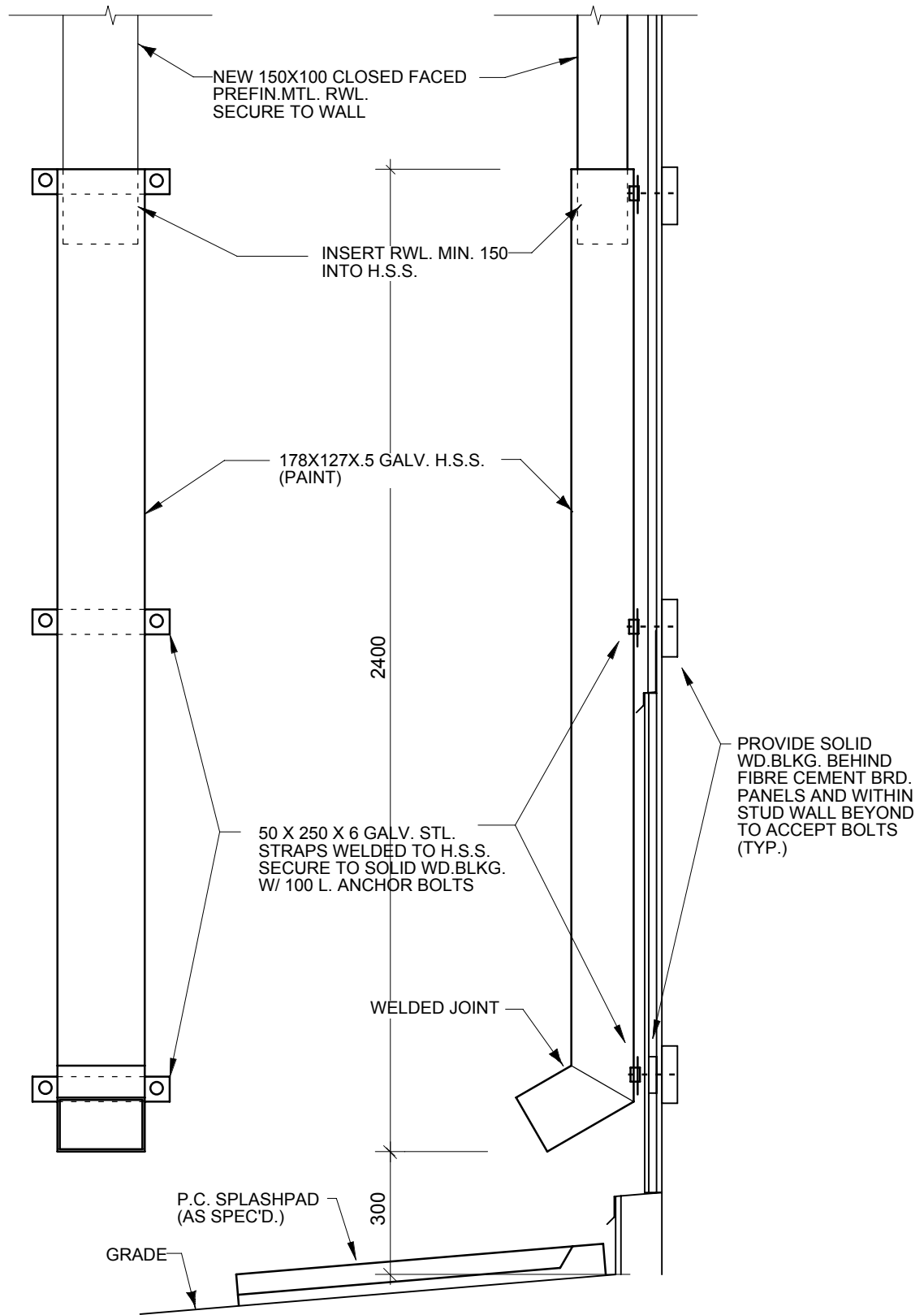

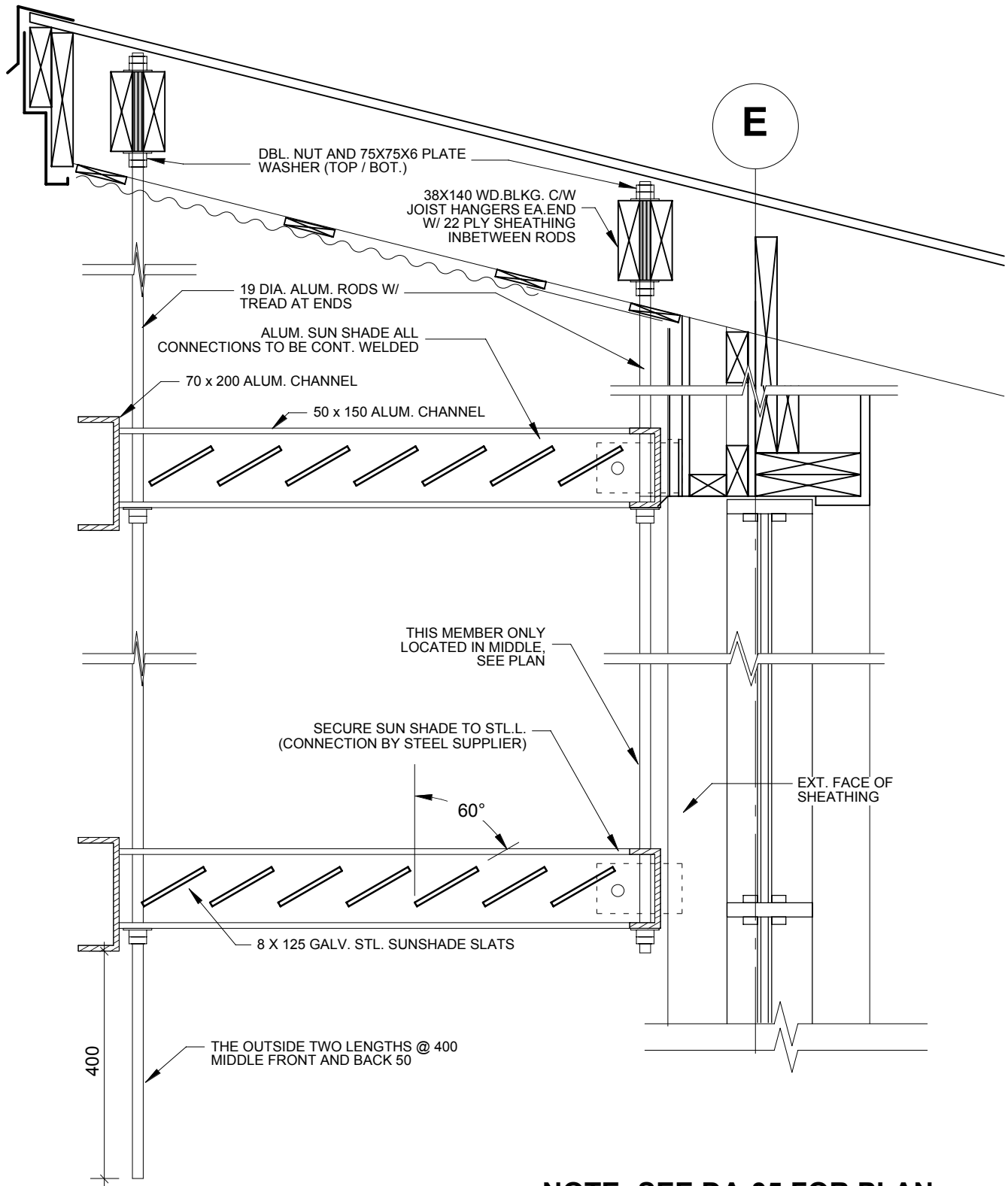

NOTE: SEE DA-35 FOR PLAN



Project Title: RED RIVER COMMUNITY CENTRE
293 MURRAY AVENUE

Sheet Title: **TYPICAL SOLAR SHADE - SECTION**

200 -141 Bannatyne Avenue East
Winnipeg • Manitoba • R3B 0R3
(204) 956-0938

Proj. No: 2003.06 Rev: R-1

Scale: 1 : 10

Date: **March 23, 2005** Detail Sheet No. **DA-16**

Printing Date: 3/23/05

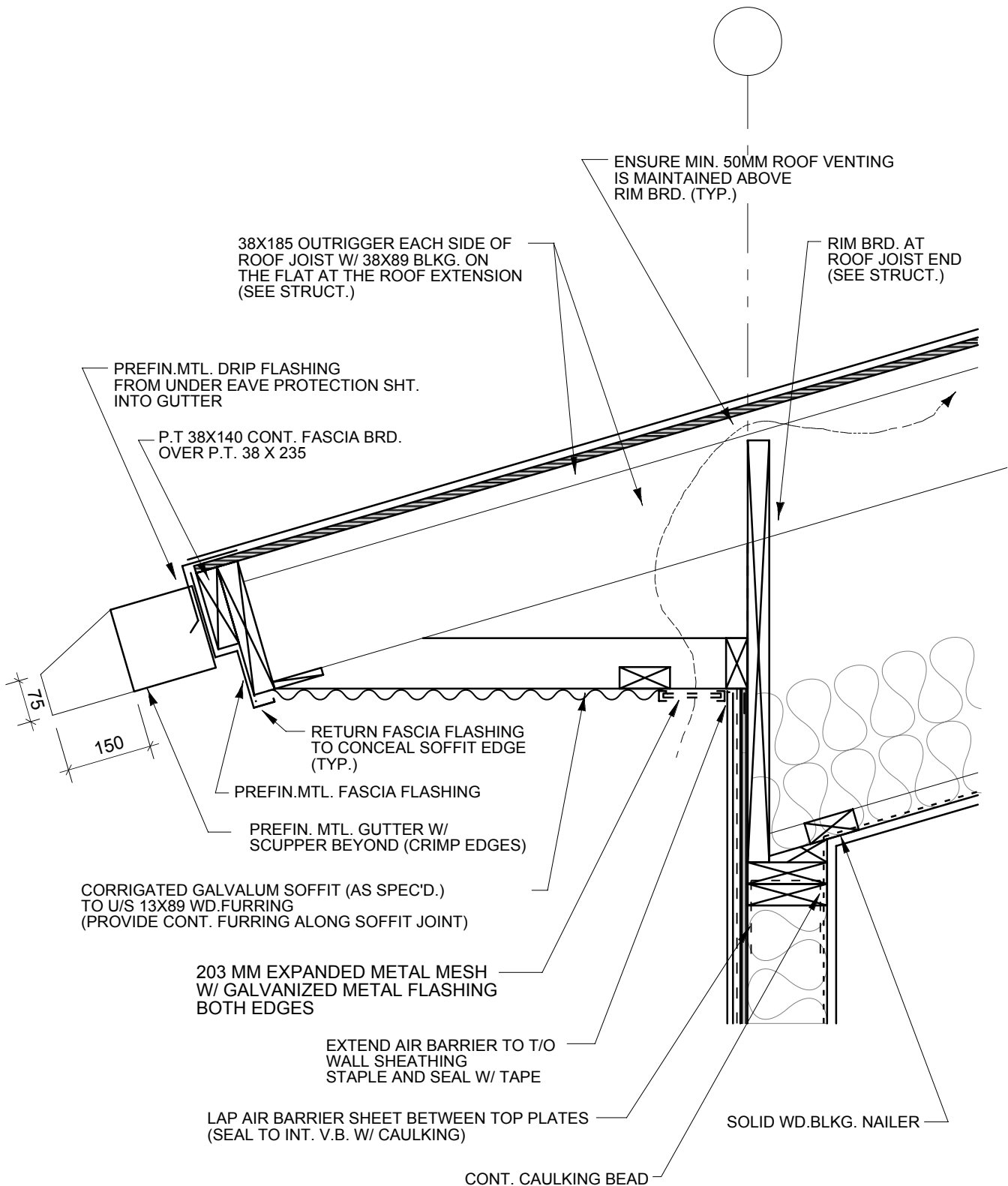

Project Title: RED RIVER COMMUNITY CENTRE
293 MURRAY AVENUE

Sheet Title: **TYPICAL EAVE SECTION**

200 -141 Bannatyne Avenue East
Winnipeg • Manitoba • R3B 0R3
(204) 956-0938

Proj. No: 2003.06 Rev: R-1

Scale: **1 : 10**

Date: **March 23, 2005** Detail Sheet No. **DA-17**

Printing Date: 3/24/05

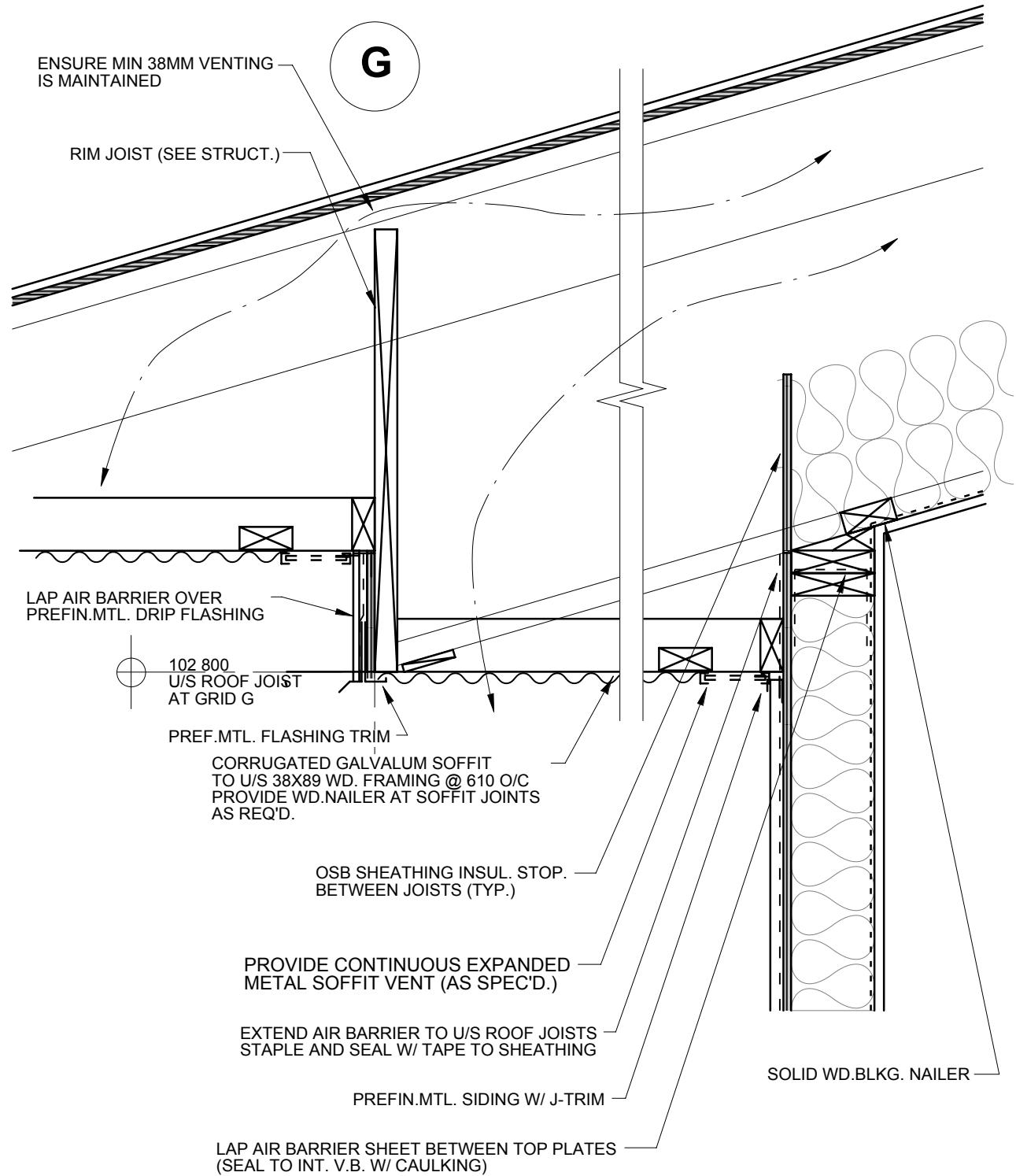

Project Title: RED RIVER COMMUNITY CENTRE
293 MURRAY AVENUE

Sheet Title: **SOFFIT SECTION**

200 -141 Bannatyne Avenue East
Winnipeg • Manitoba • R3B 0R3
(204) 956-0938

Proj. No: 2003.06 Rev: R-1

Scale: 1 : 10

Date: **March 23, 2005** Detail Sheet No. **DA-18**

Printing Date: 3/23/05

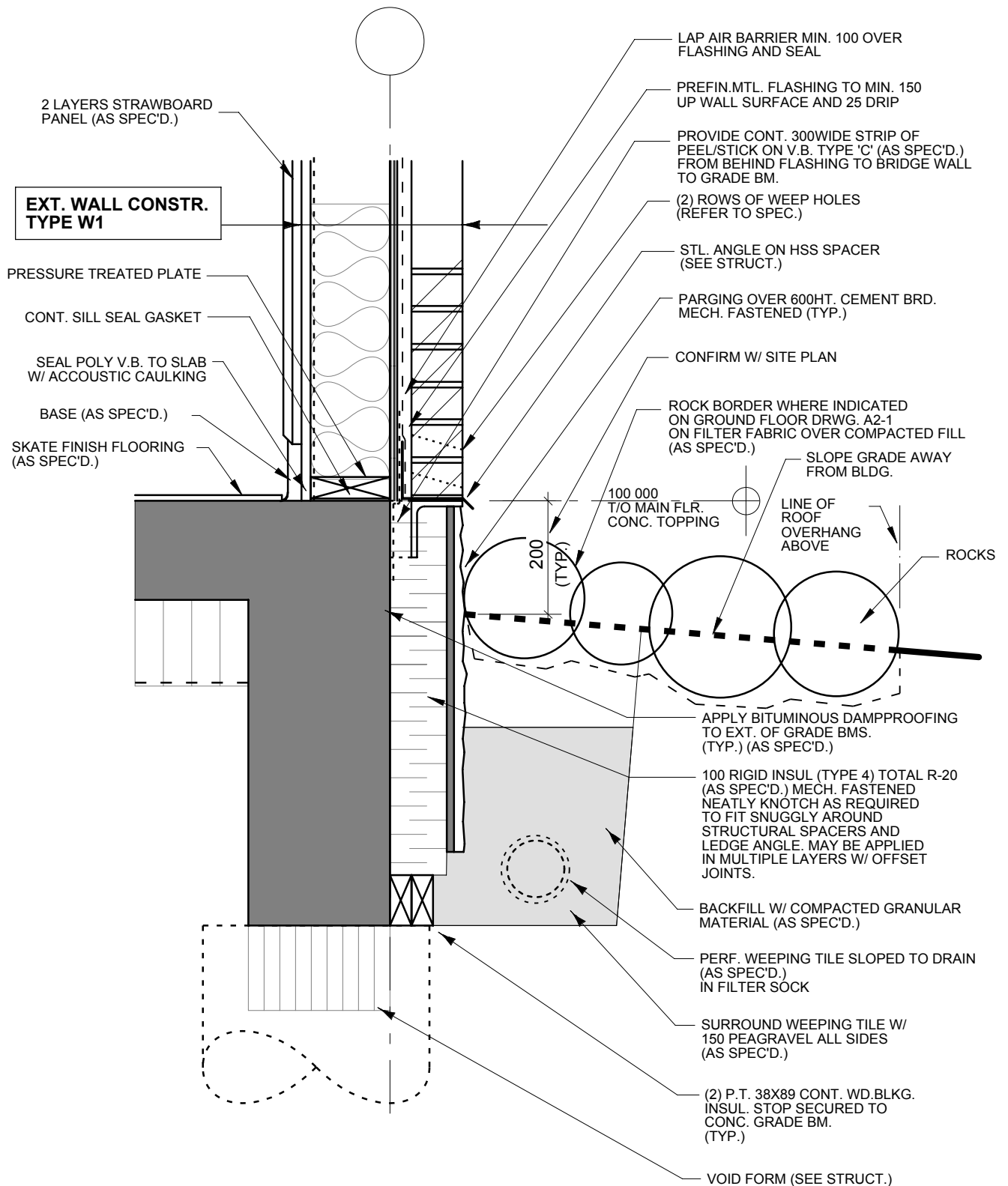

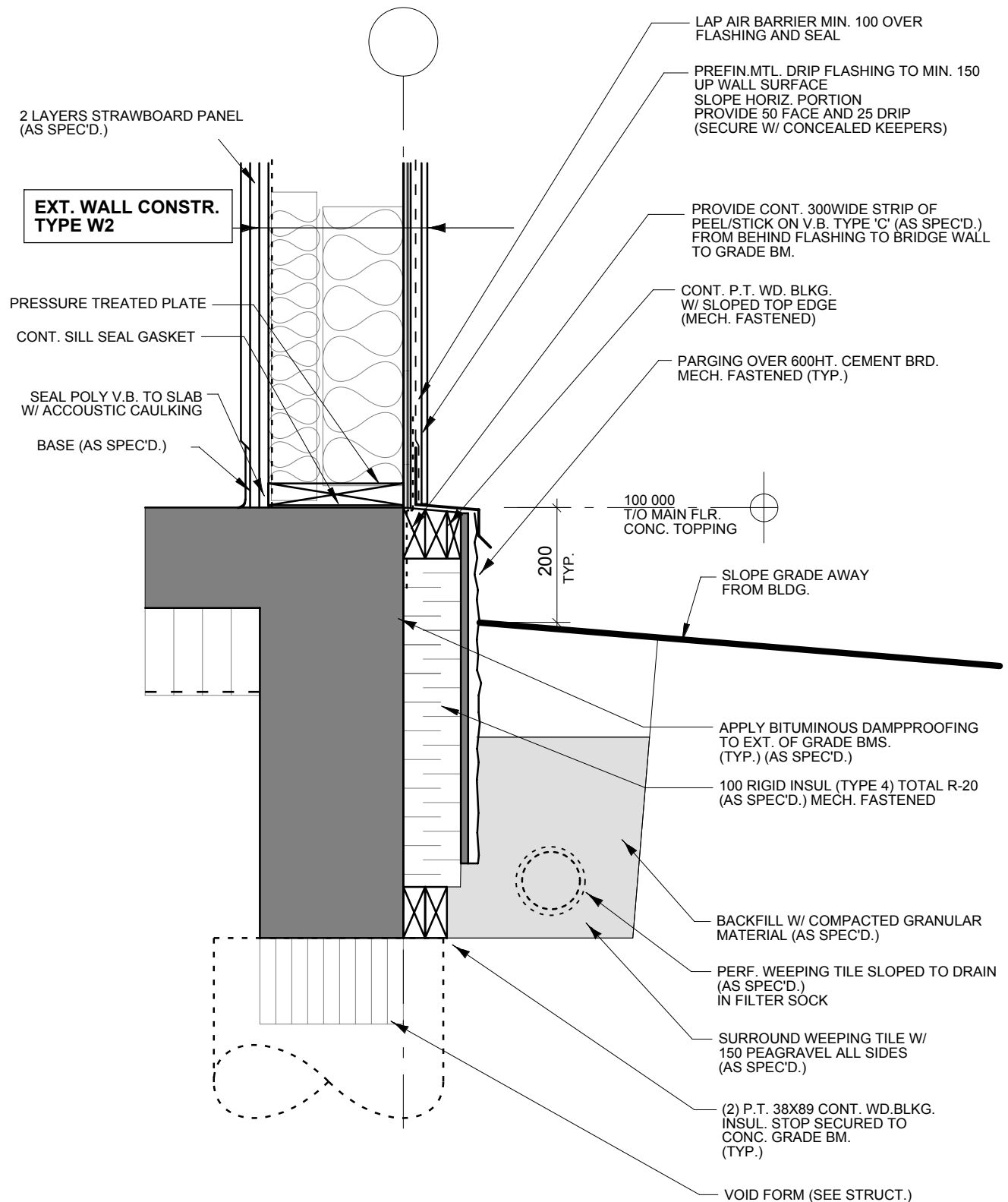

PRAIRIE
ARCHITECTS INC.

200 -141 Bannatyne Avenue East
Winnipeg • Manitoba • R3B 0R3
(204) 956-0938

Project Title: RED RIVER COMMUNITY CENTRE
293 MURRAY AVENUE

Sheet Title: **TYPICAL FOUNDATION SECTION AT FIBRE CEMENT PANELS**

Proj. No: 2003.06 Rev: R-1

Scale: 1 : 10

Date: **March 23, 2005** Detail Sheet No. **DA-20**

Printing Date: 3/24/05

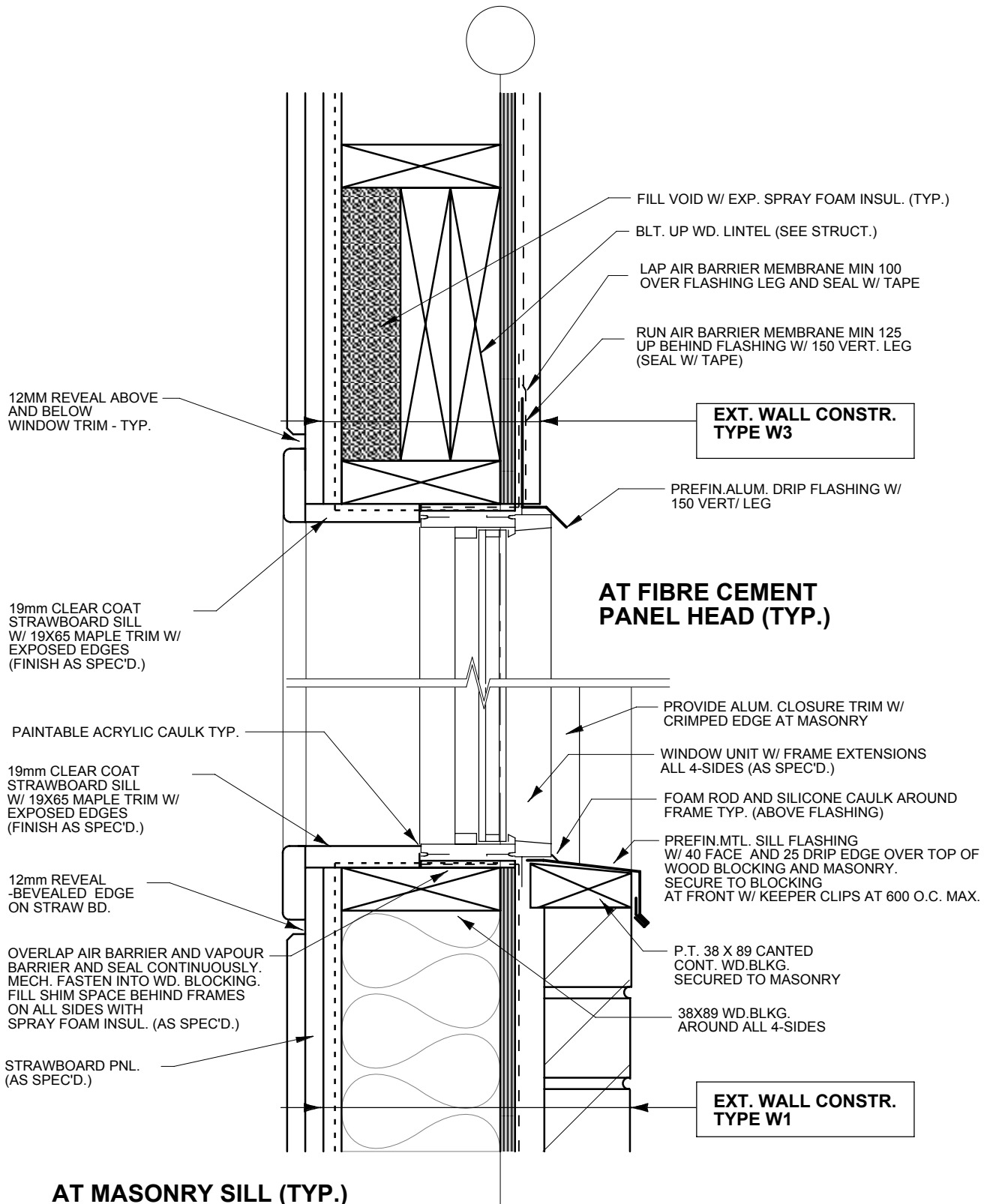

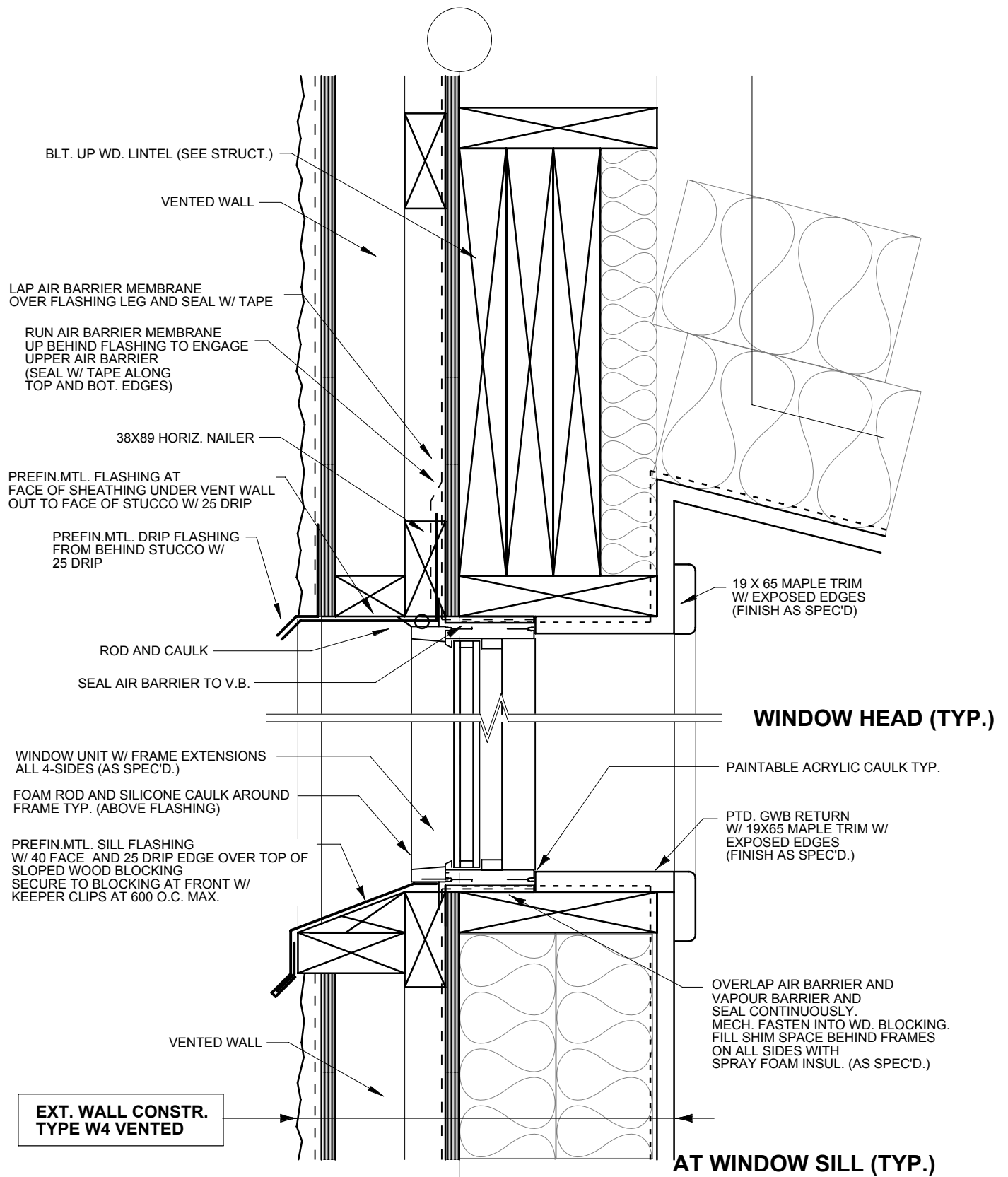

Project Title: RED RIVER COMMUNITY CENTRE
293 MURRAY AVENUE

Sheet Title: **TYPICAL WINDOW SILL / HEAD AT VENTED WALL**

200 -141 Bannatyne Avenue East
Winnipeg • Manitoba • R3B 0R3
(204) 956-0938

Proj. No: 2003.06 Rev: R-1

Scale: 1 : 5

Date: **March 23, 2005**

Detail Sheet No. **DA-22**

Printing Date: 3/24/05

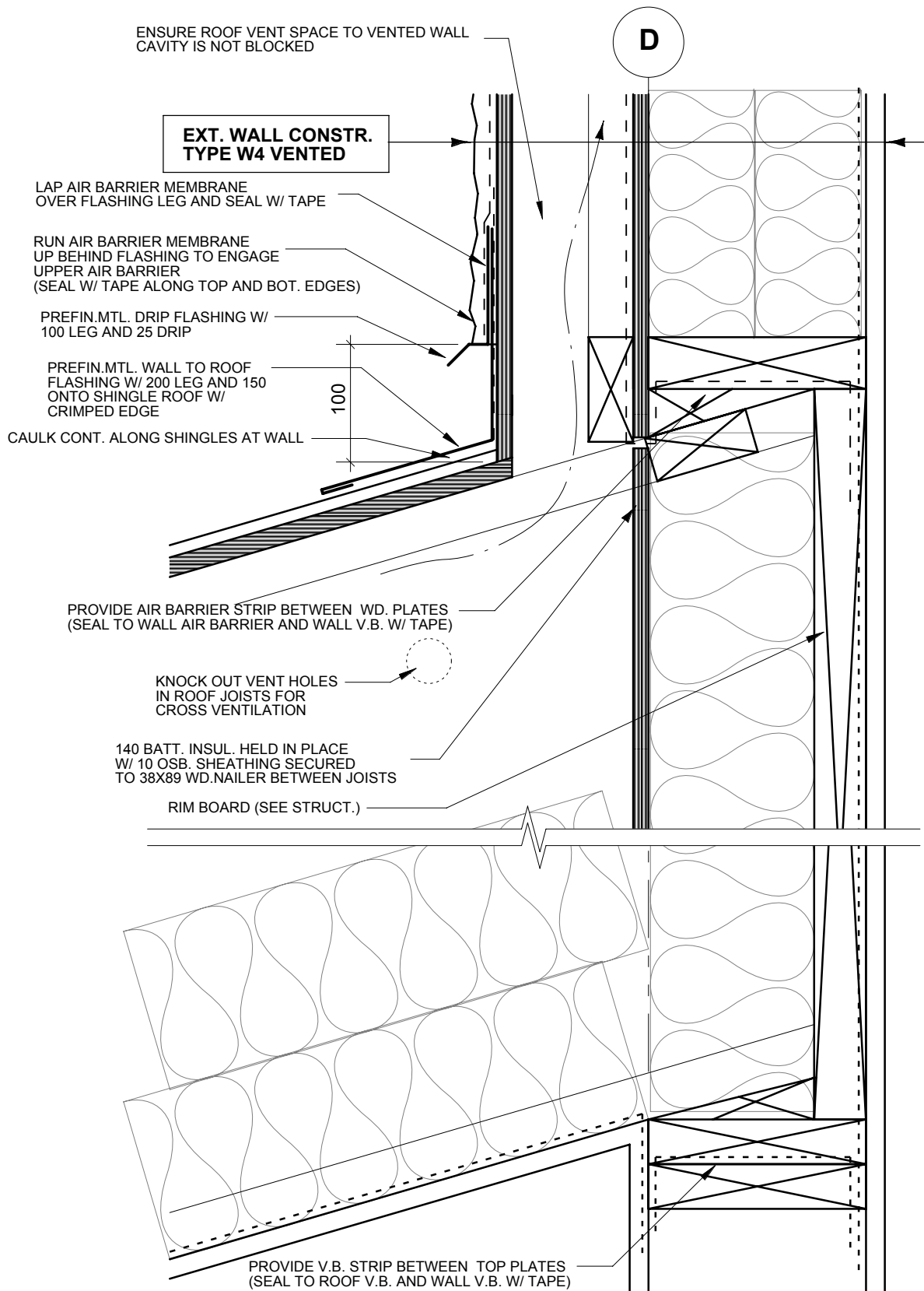

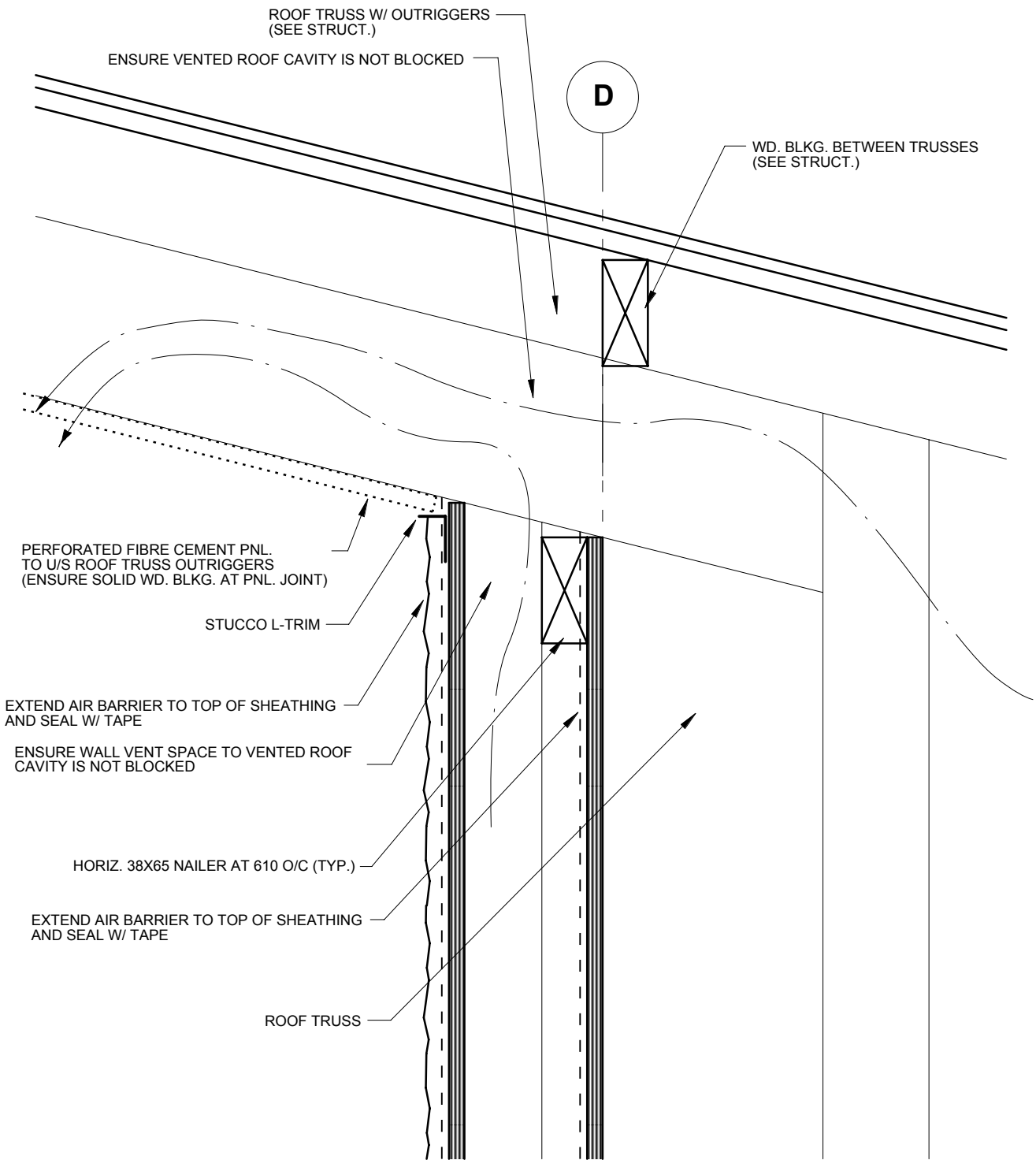

PRAIRIE
ARCHITECTS INC.

Project Title: RED RIVER COMMUNITY CENTRE
293 MURRAY AVENUE

Sheet Title: **TYPICAL VENTED WALL TO ROOF**

200 -141 Bannatyne Avenue East
Winnipeg • Manitoba • R3B 0R3
(204) 956-0938

Proj. No: 2003.06 Rev: R-1

Scale: 1 : 5

Date: March 23, 2005

Detail Sheet No.

DA-24

Printing Date:

3/17/05

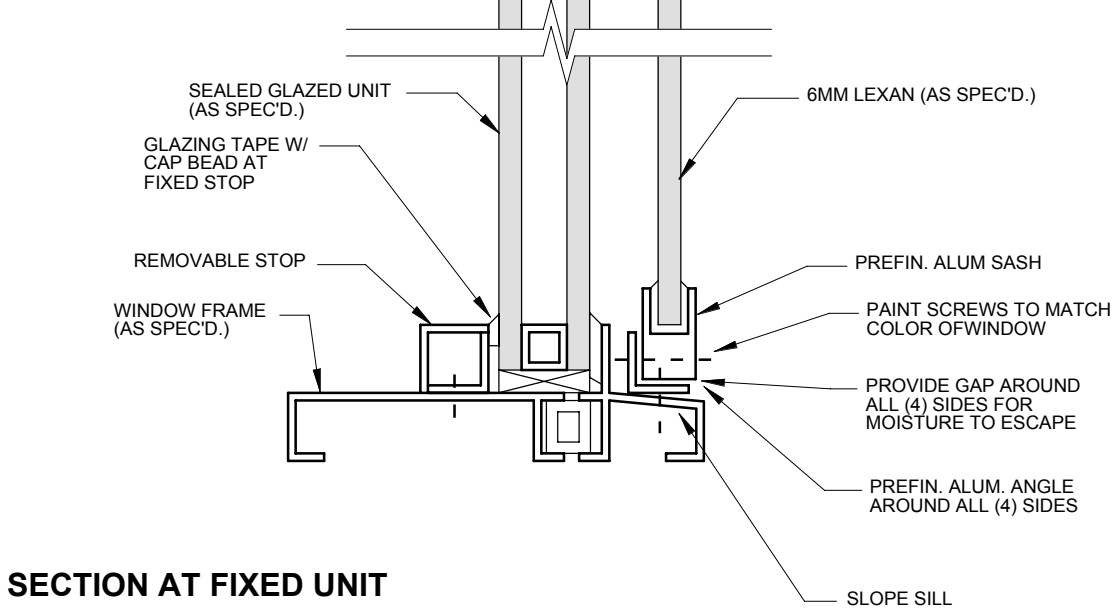
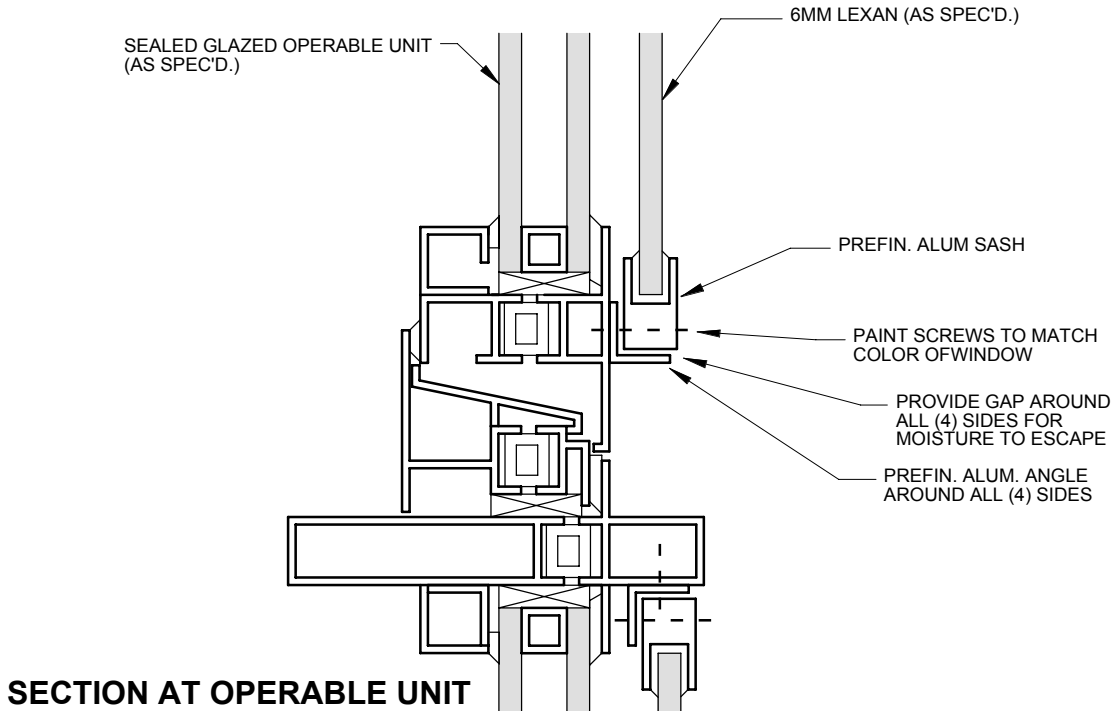

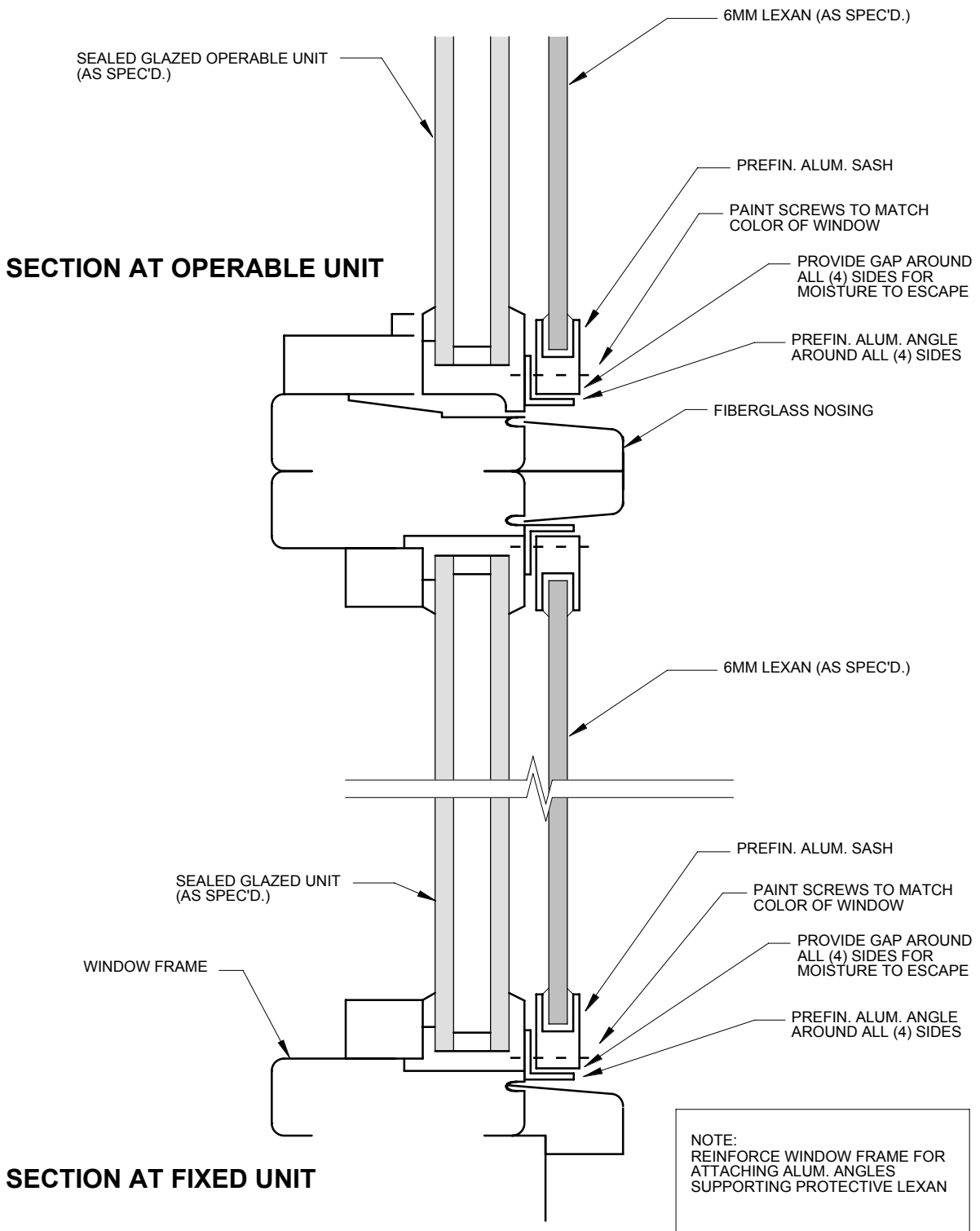

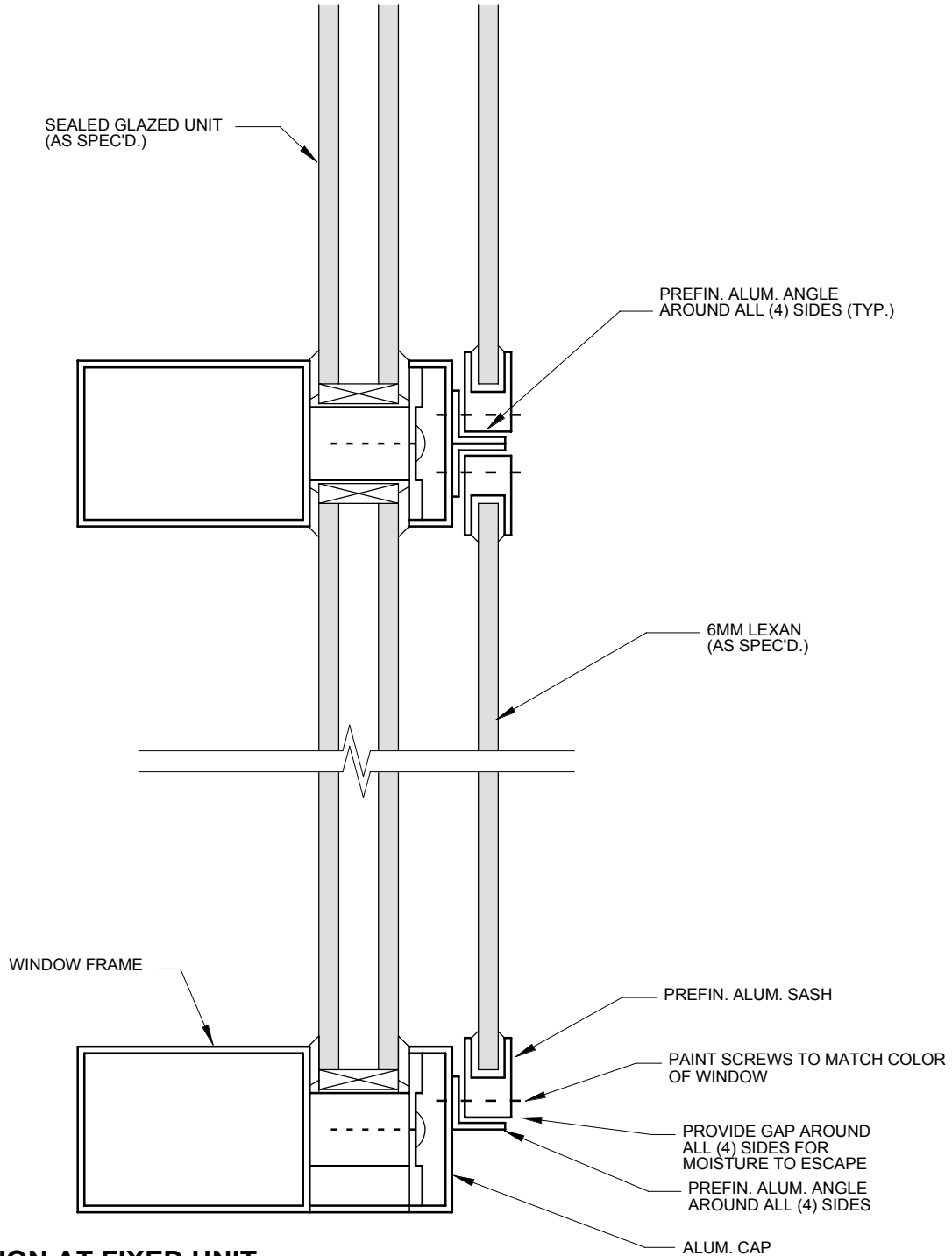

SECTION AT FIXED UNIT

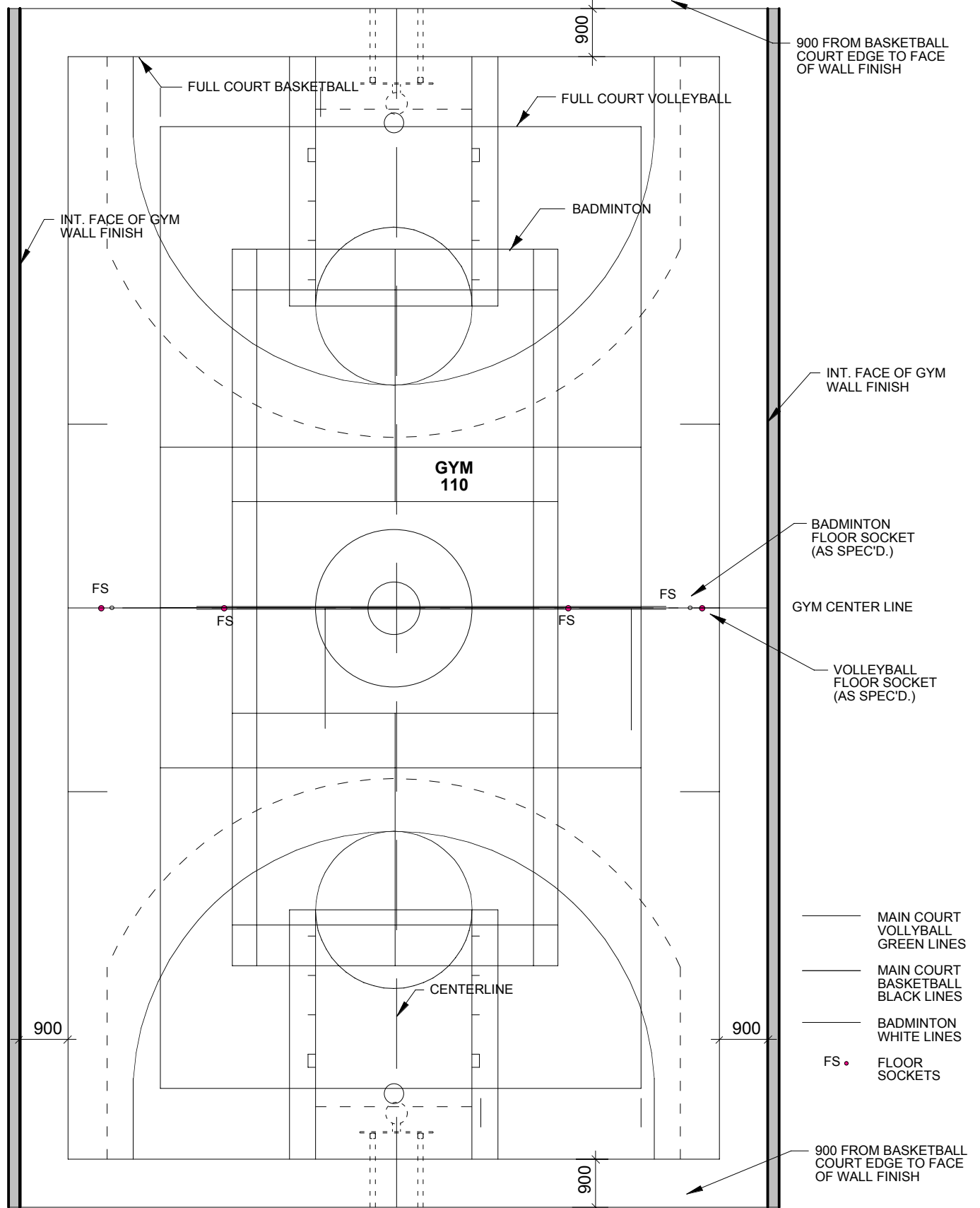

PRAIRIE
ARCHITECTS INC.

Project Title: **RED RIVER COMMUNITY CENTRE**
293 MURRAY AVENUE
Sheet Title: **GYMNASIUM GAME LINES LAYOUT**

200 -141 Bannatyne Avenue East
Winnipeg • Manitoba • R3B 0R3
(204) 956-0938

Proj. No: 2003.06 Rev: R-2
Scale: 1 : 100 Date: **March 23, 2005**

Detail Sheet No. **DA-28**

Printing Date: 4/11/05

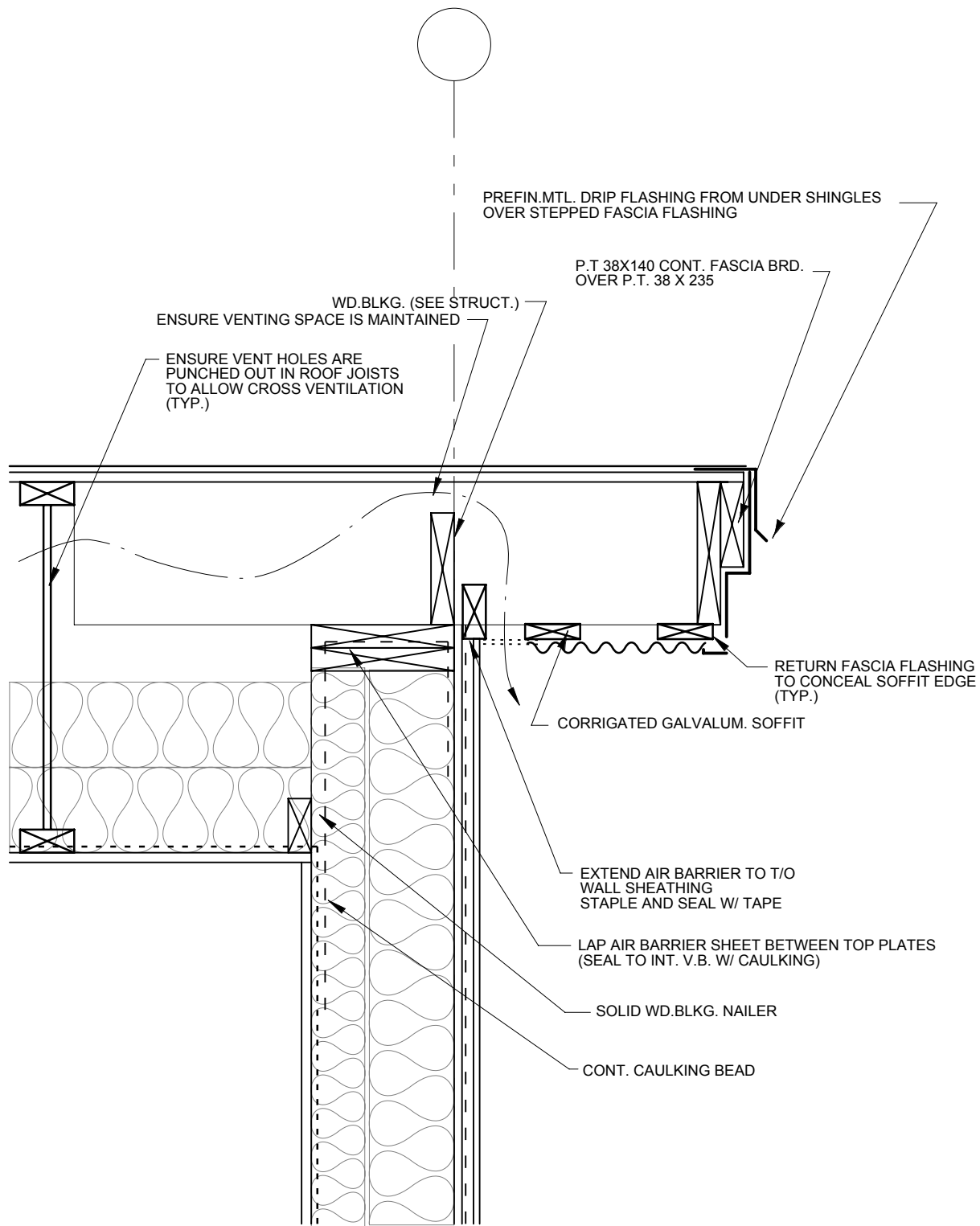

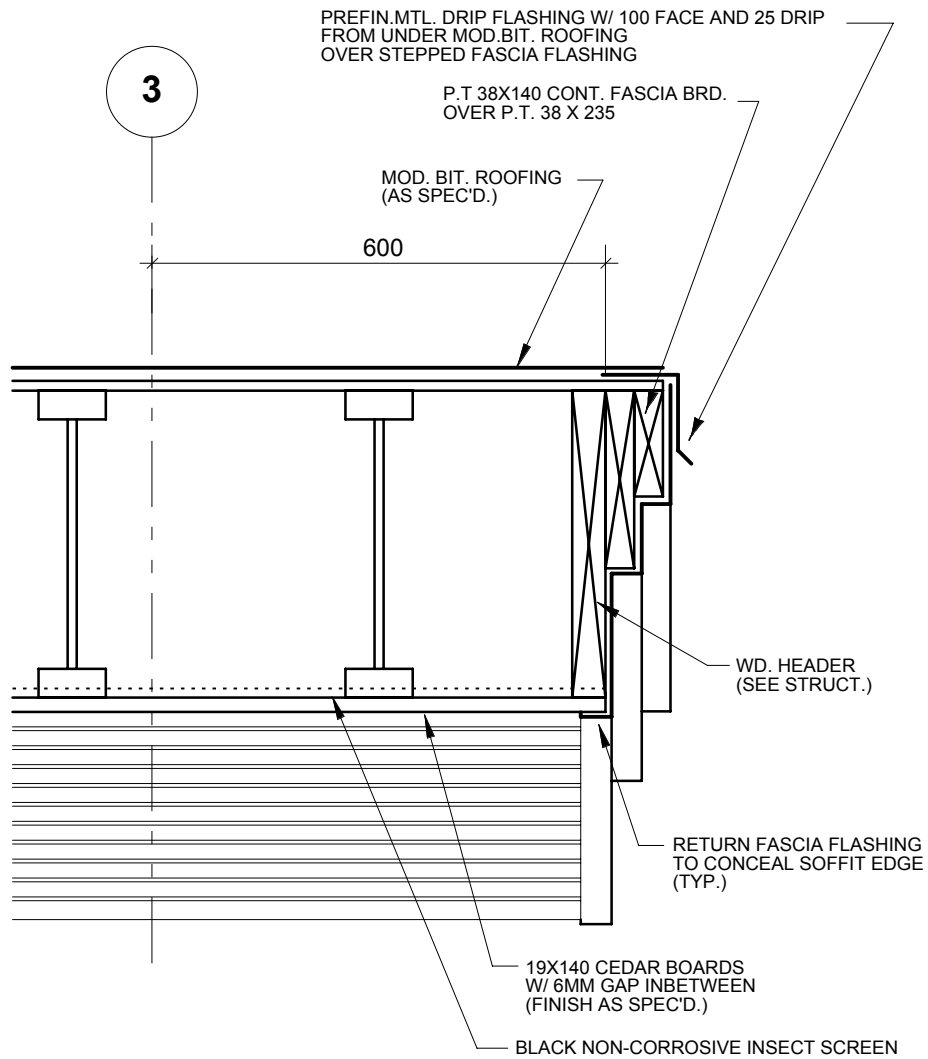

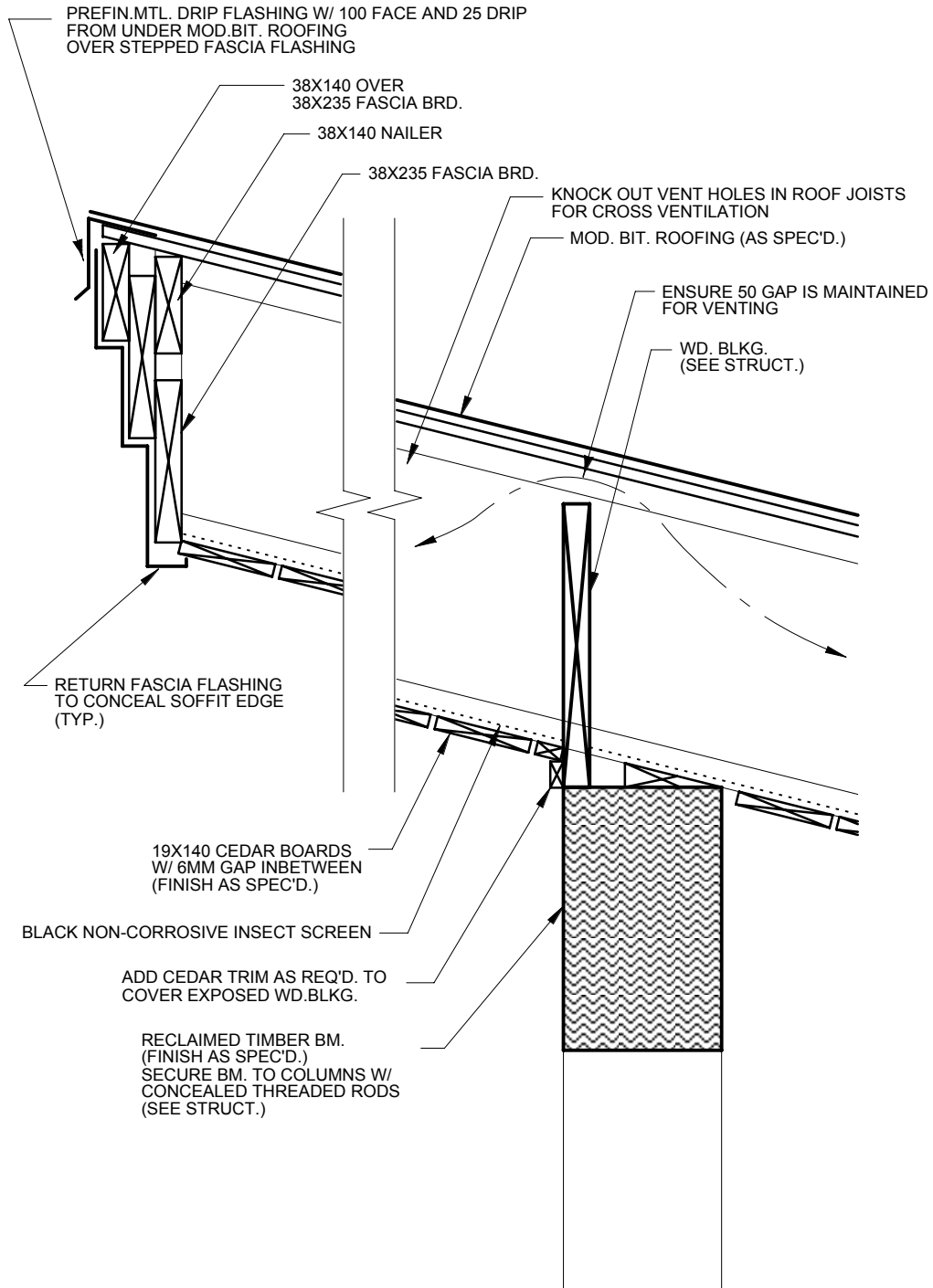

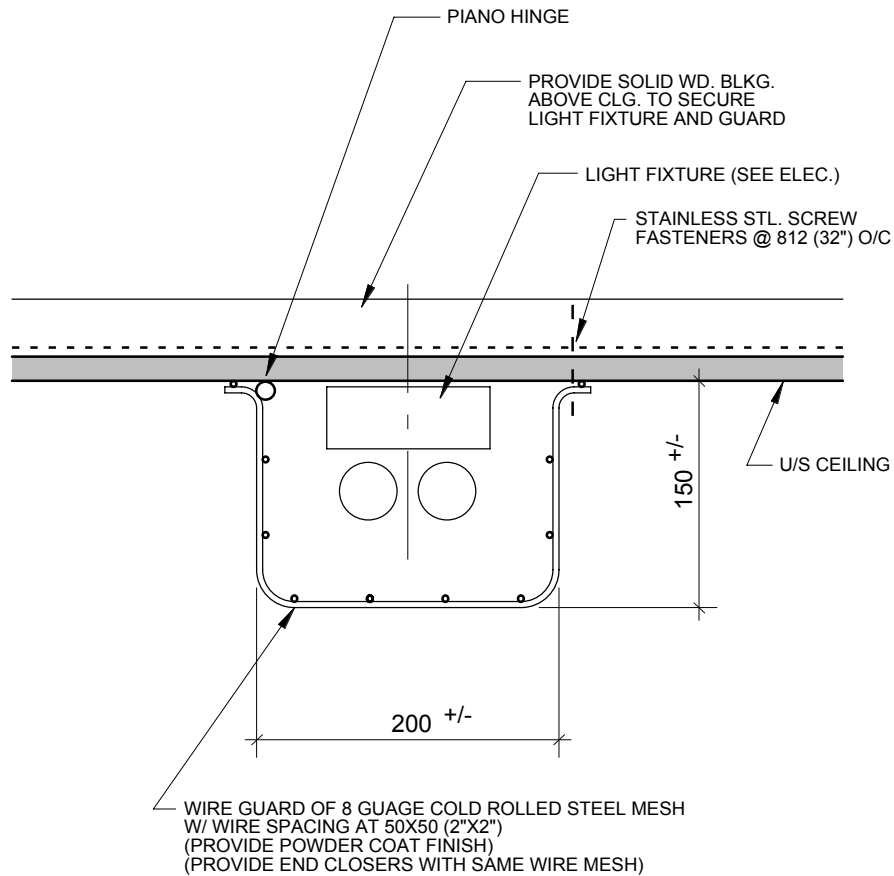

NOTE:
CONFIRM MIN. 38MM CLEARANCE AROUND FIXTURE AND LIGHT BULBS

NOTE:
WIRE GUARDS TO BE IN SECTIONS RELATING TO THE LENGTH OF LIGHT FIXTURES
2440 (8FT.) OR 1220 (4FT.) CONFIRM W/ ELEC.

PRAIRIE
ARCHITECTS INC.

Project Title: RED RIVER COMMUNITY CENTRE
293 MURRAY AVENUE

Sheet Title: **LIGHT FIXTURE GUARD**

200 -141 Bannatyne Avenue East
Winnipeg • Manitoba • R3B 0R3
(204) 956-0938

Proj. No: 2003.06

Rev: **R-1**

Scale: **1 : 5**

Date: **March 23, 2005**

Detail Sheet No.

DA-32

Printing Date:

3/17/05

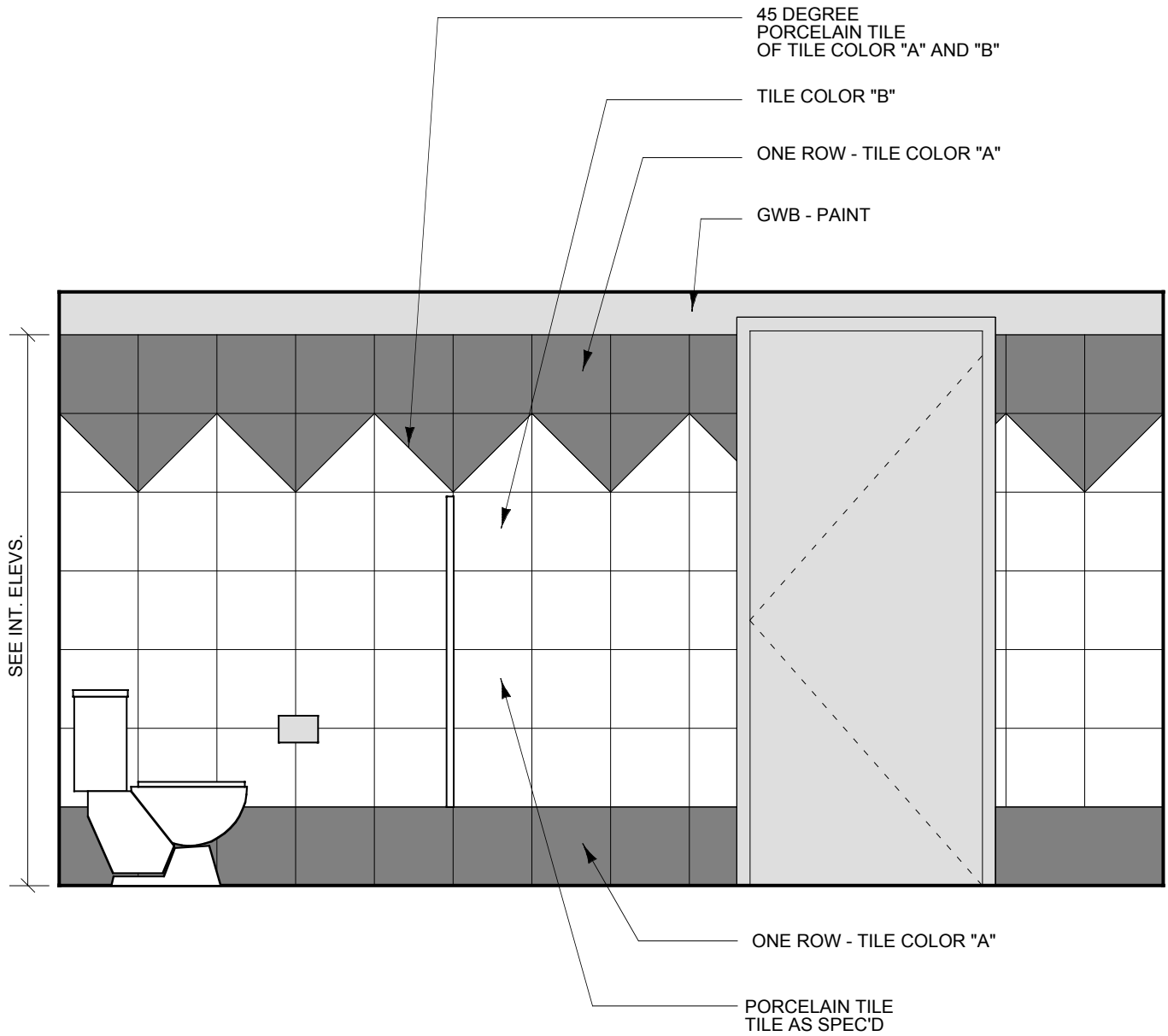

WASHROOM ELEVATION - TYP.

PRAIRIE
ARCHITECTS INC.

200 -141 Bannatyne Avenue East
Winnipeg • Manitoba • R3B 0R3
(204) 956-0938

Project Title: RED RIVER COMMUNITY CENTRE
Winnipeg, Manitoba

Sheet Title: **W/C TILE PATTERN**

Proj. No: 2003.06

Rev: **R-1**

Scale: **1 : 25**

Date: **March 23, 2005** Detail Sheet No.

DA-33

R-0

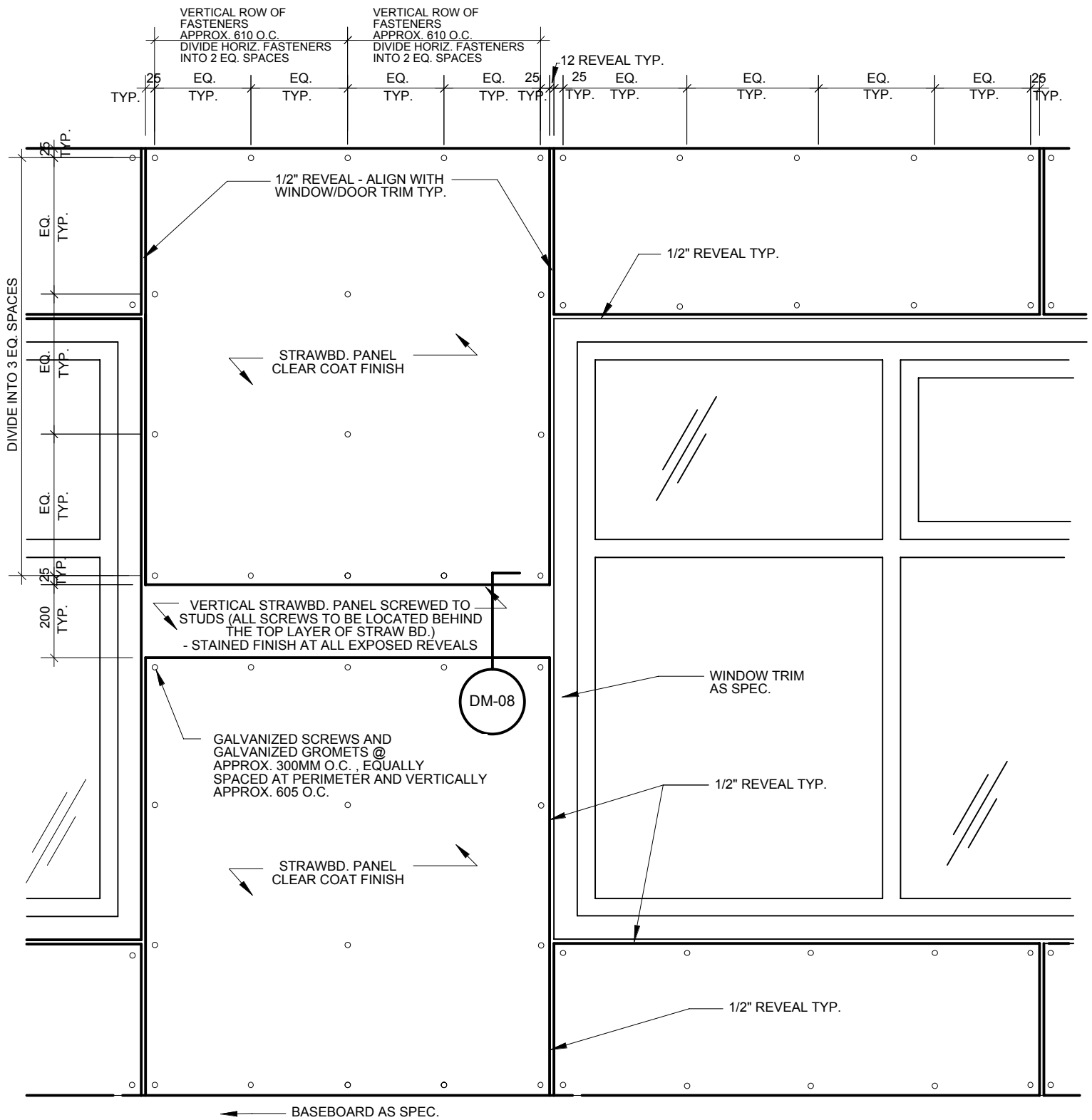

NOTE: CONFIRM FASTENER SPACING W/
PANEL SUPPLIER

NOTE: SEE OTHER DETAILS FOR SPECIAL
TRIM CONDITIONS



Project Title: RED RIVER COMMUNITY CENTRE
293 MURRAY AVENUE
Sheet Title: **STRAWBOARD ELEVATION @ WINDOW**

200 -141 Bannatyne Avenue East
Winnipeg • Manitoba • R3B 0R3
(204) 956-0938

Proj. No: 2003.06 Rev: R-1
Scale: 1 : 15 Date: March 23, 2005 Detail Sheet No.

DA-34

Printing Date: 3/24/05

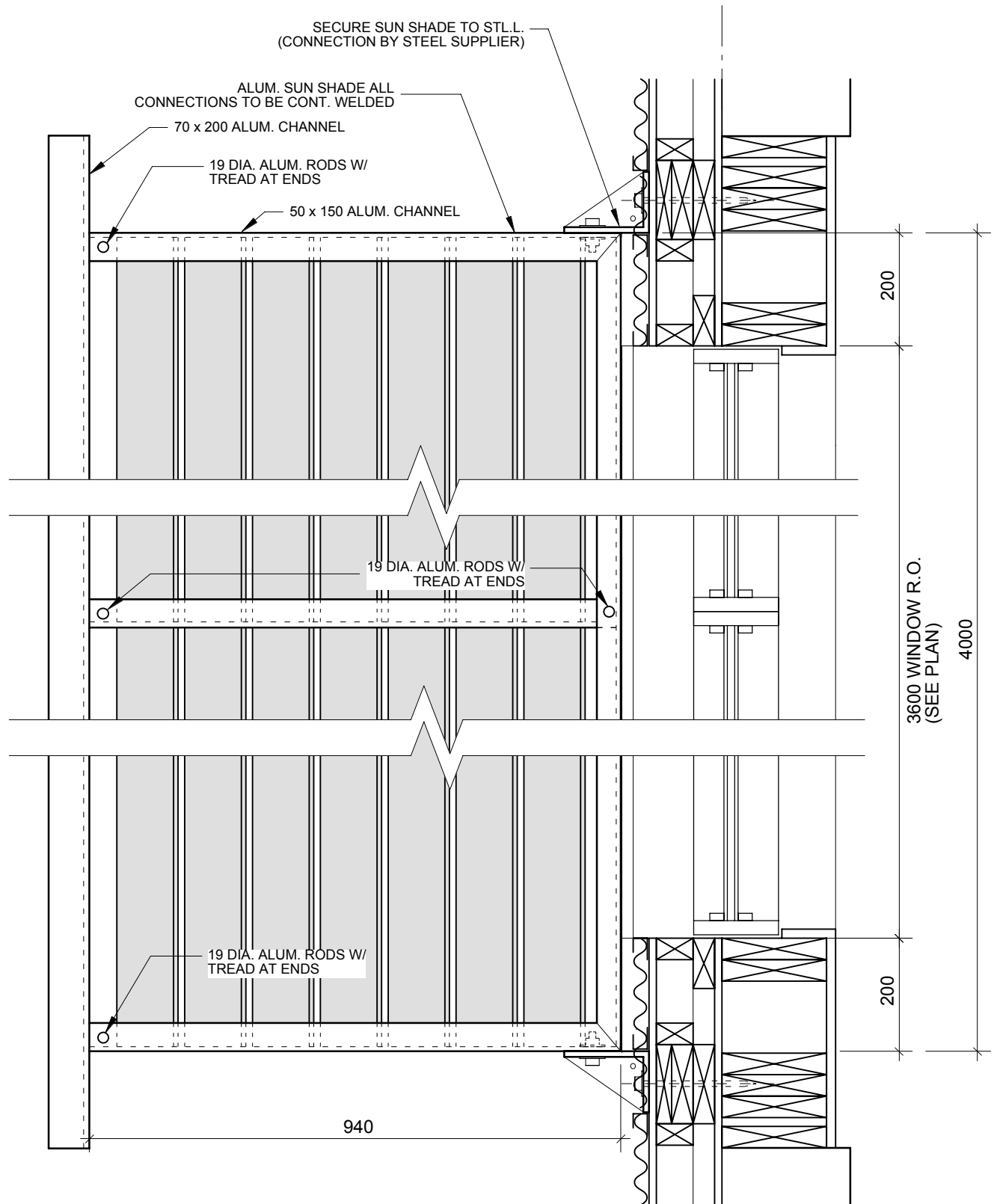

NOTE: SEE DA-16 FOR SECTION



Project Title: RED RIVER COMMUNITY CENTRE
293 MURRAY AVENUE

Sheet Title: **TYPICAL SOLAR SHADE - PLAN**

200 -141 Bannatyne Avenue East
Winnipeg • Manitoba • R3B 0R3
(204) 956-0938

Proj. No: 2003.06 Rev: R-1

Scale: **1 : 10**

Date: **March 23, 2005** Detail Sheet No. **DA-35**

Printing Date: 3/23/05

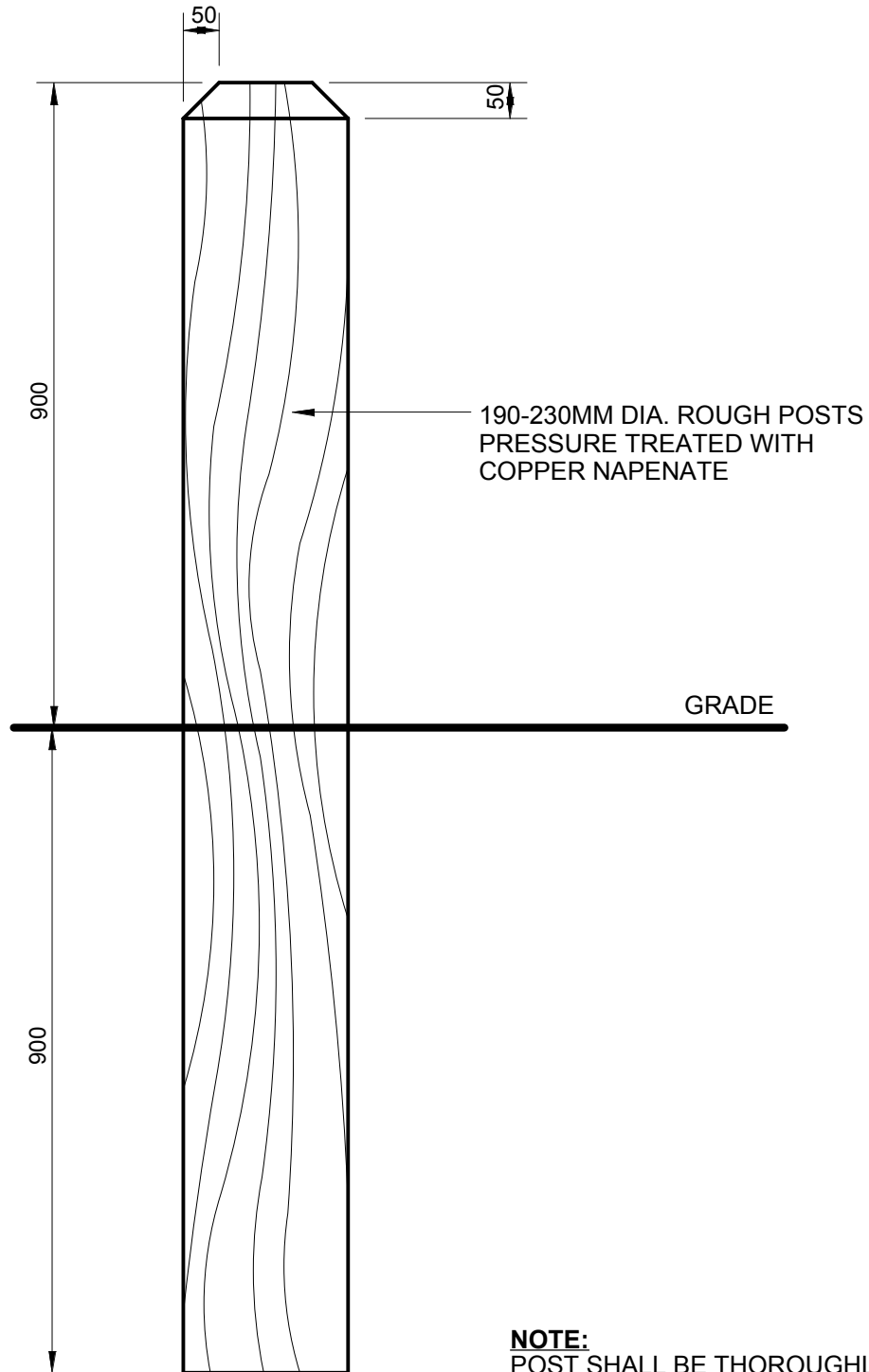

NOTE:
 POST SHALL BE THOROUGHLY
 TAMPED AND EARTH MOUNDED
 APPROX. 100MM FOR FUTURE
 SETTLING



Project Title: RED RIVER COMMUNITY CENTRE
 293 MURRAY AVENUE

Sheet Title: **TYPICAL ROUND WOOD BOLLARD**

200 -141 Bannatyne Avenue East
 Winnipeg • Manitoba • R3B 0R3
 (204) 956-0938

Proj. No: 2003.06 Rev: R-1

Scale: **1 : 10**

Date: **March 23, 2005** Detail Sheet No. **DA-36**

Printing Date: 4/12/05

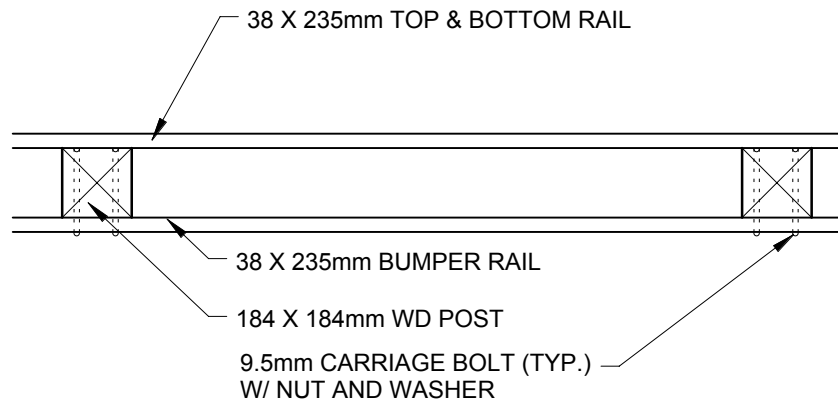

PLAN VIEW

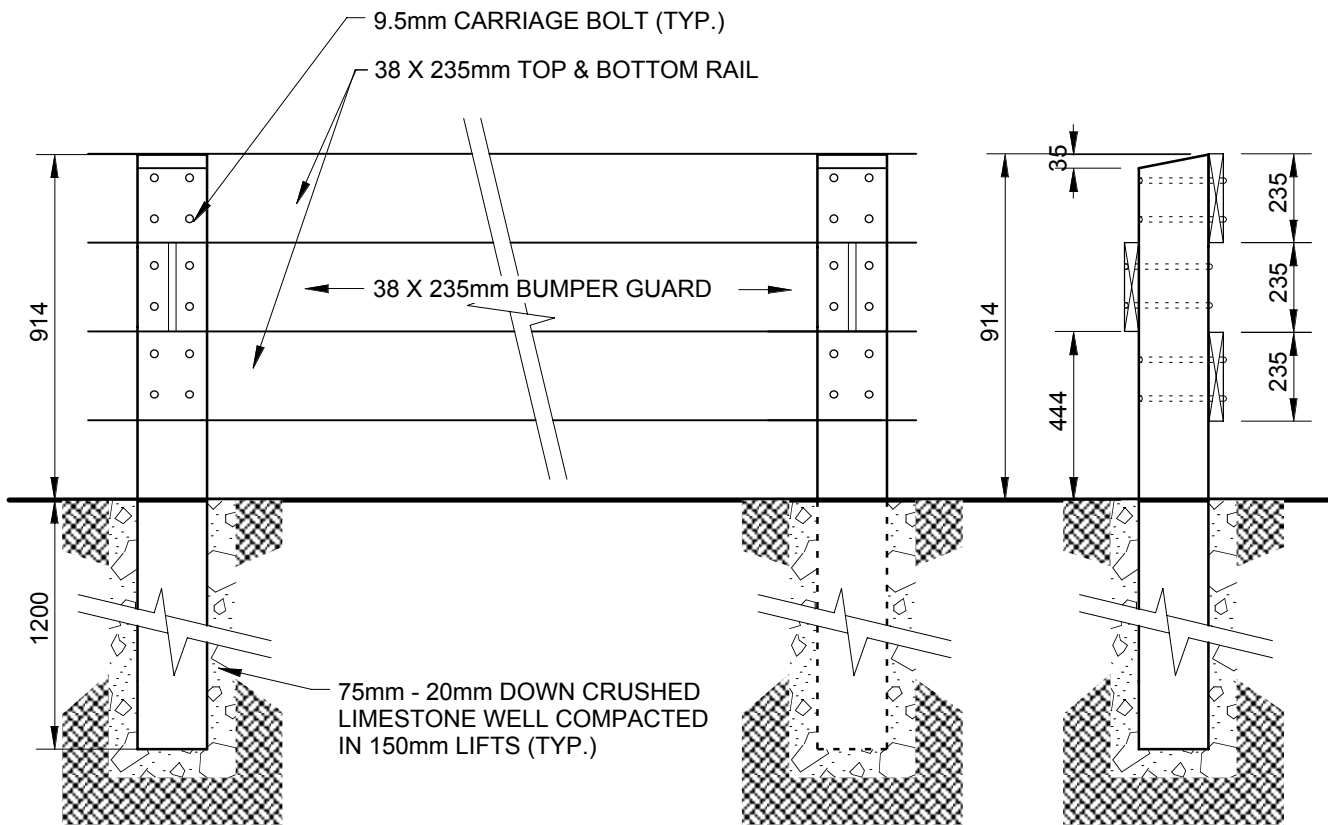

ELEVATION

SECTION

- NOTE:
1. ALL LUMBER TO BE PRESSURE TREATED WITH COPPER NATHENATE
 2. ALL FASTENERS SHALL BE GALVANIZED OR PLATED



Project Title: RED RIVER COMMUNITY CENTRE
293 MURRAY AVENUE

Sheet Title: **TYPICAL LIGHT-PROOF BARRIER/FENCE**

200 -141 Bannatyne Avenue East
Winnipeg • Manitoba • R3B 0R3
(204) 956-0938

Proj. No: 2003.06 Rev: R-1

Scale: 1 : 20

Date: **March 23, 2005** Detail Sheet No. **DA-37**

Printing Date: 4/12/05

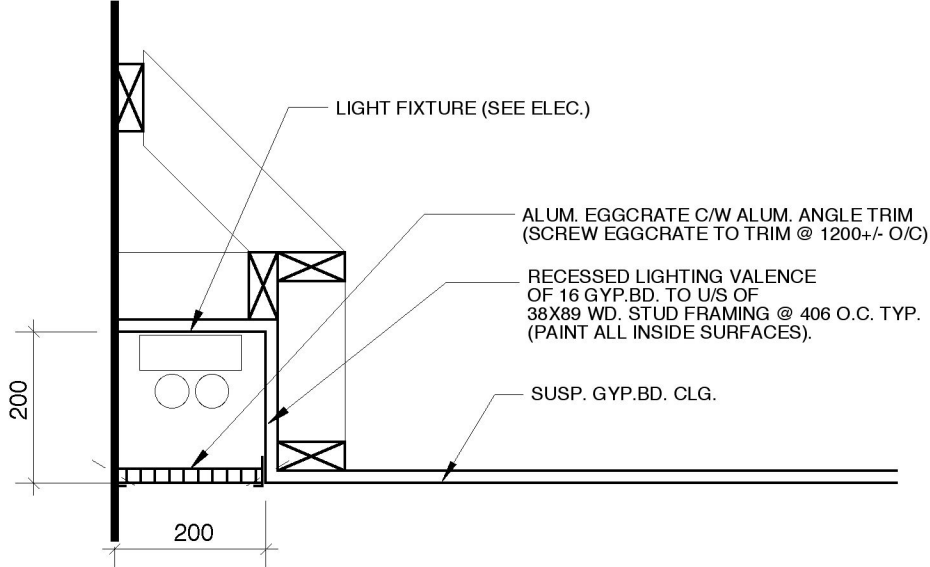

(B) TYPICAL W.C. LIGHTING VALENCE

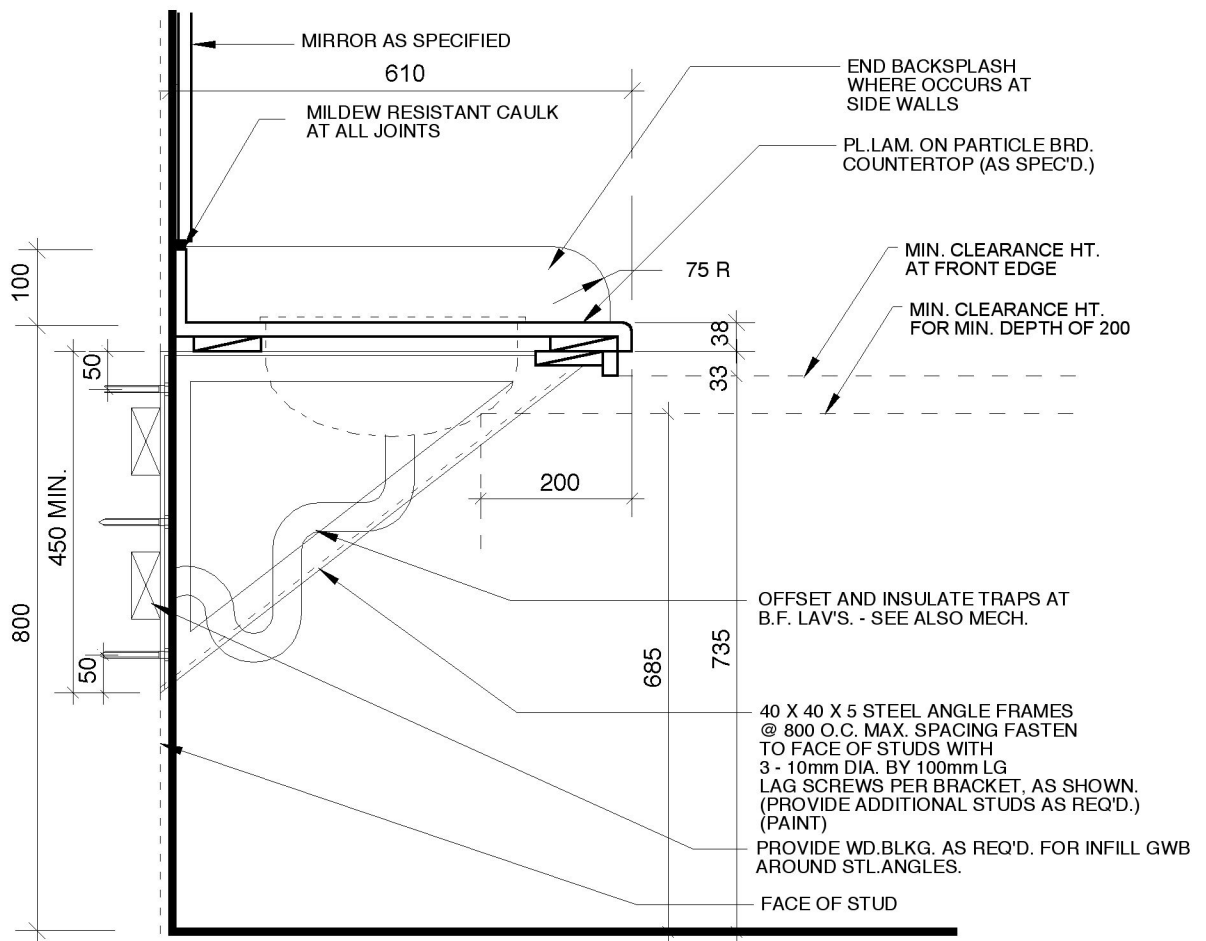

(A) TYPICAL W.C. VANITY (BARRIER FREE)

REFER TO SPECIFICATIONS FOR HARDWARE & FINISH SCHEDULES. ENSURE BLOCKING IN WALL TO SECURE MILLWORK.

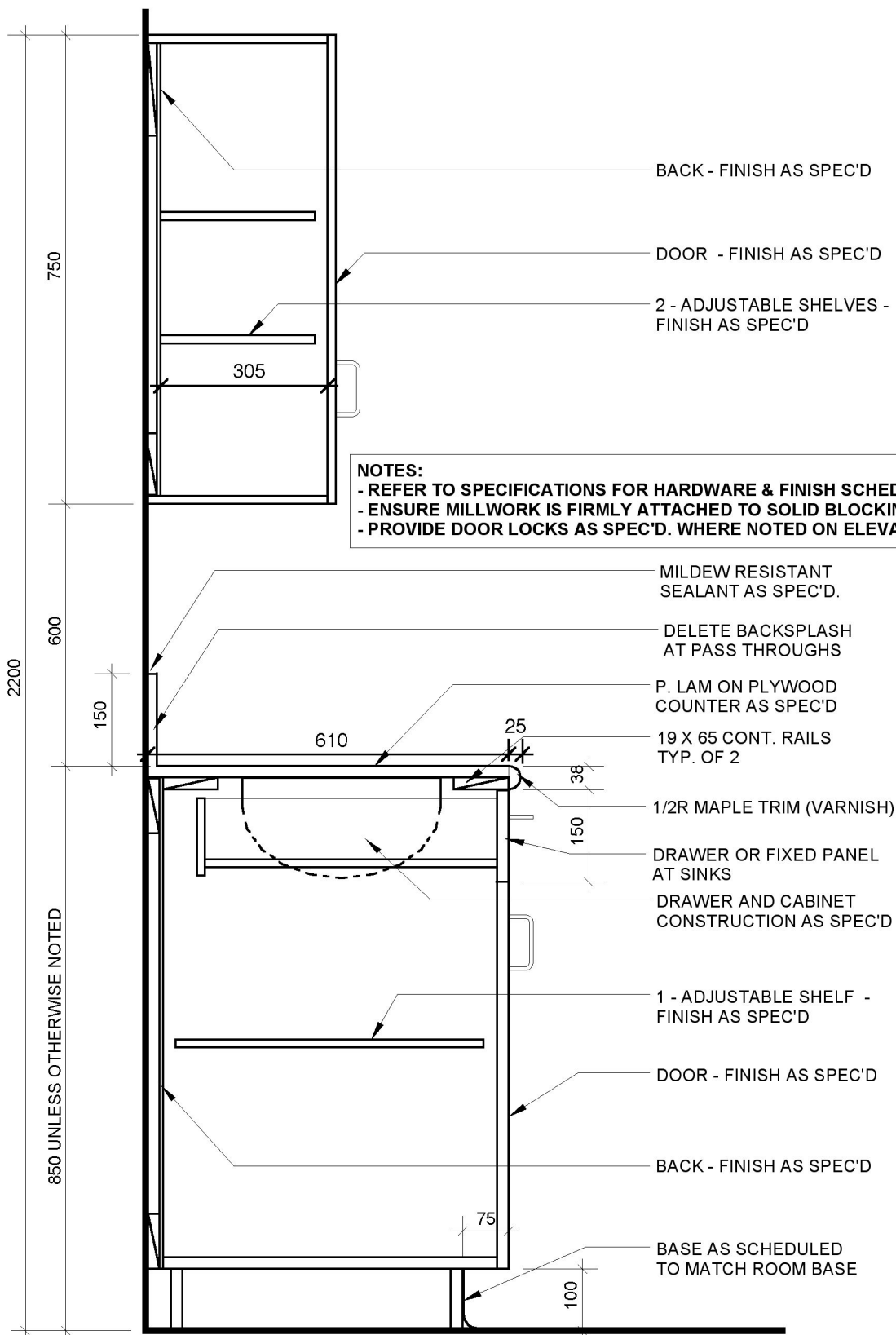

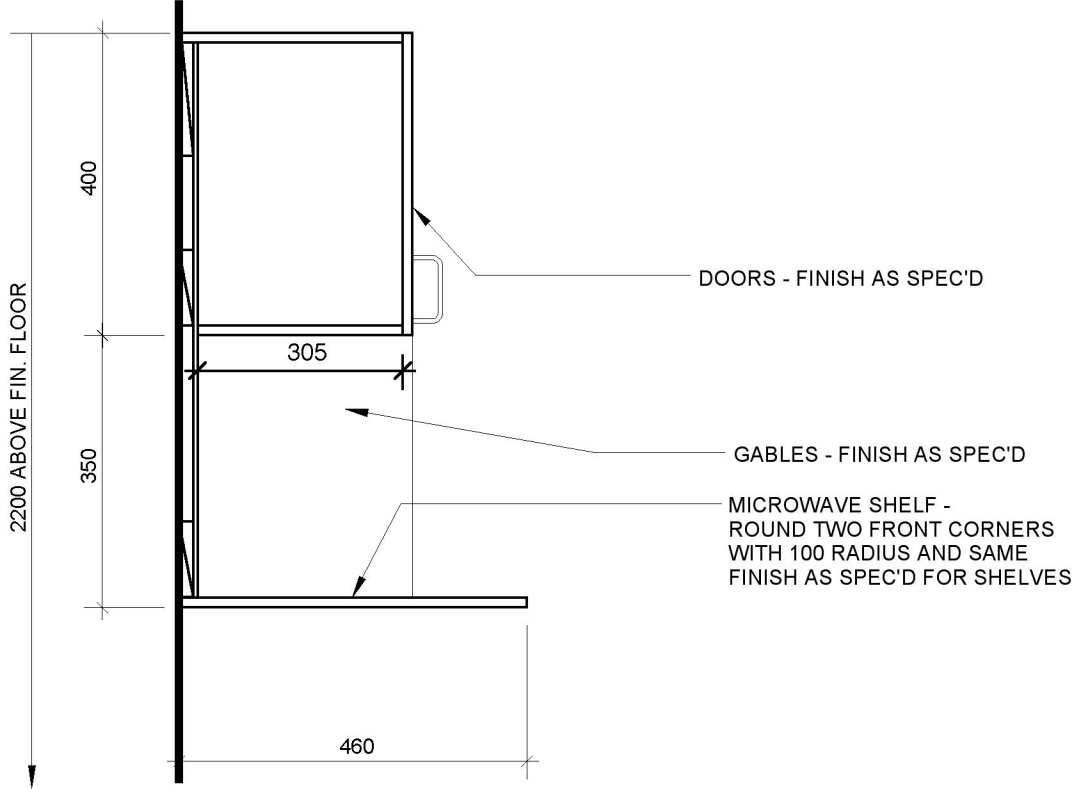

(B) TYPICAL UPPER CABINET AT MICROWAVE SHELF

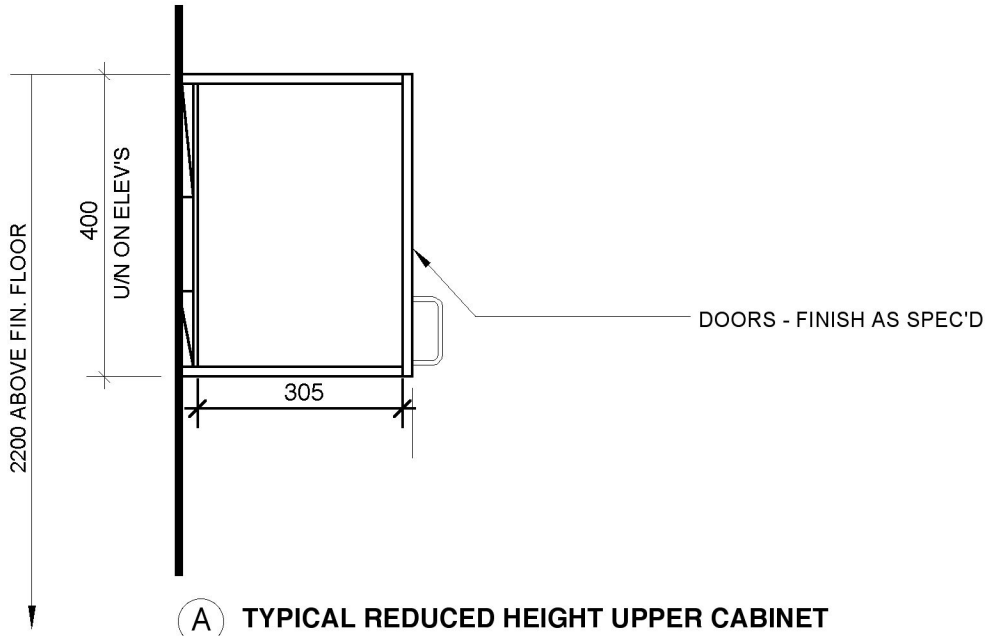

(A) TYPICAL REDUCED HEIGHT UPPER CABINET

NOTES:
 - REFER TO SPECIFICATIONS FOR HARDWARE & FINISH SCHEDULES.
 - ENSURE MILLWORK IS FIRMLY ATTACHED TO SOLID BLOCKING IN WALLS
 - PROVIDE DOOR LOCKS AS SPEC'D. WHERE NOTED ON ELEVATIONS

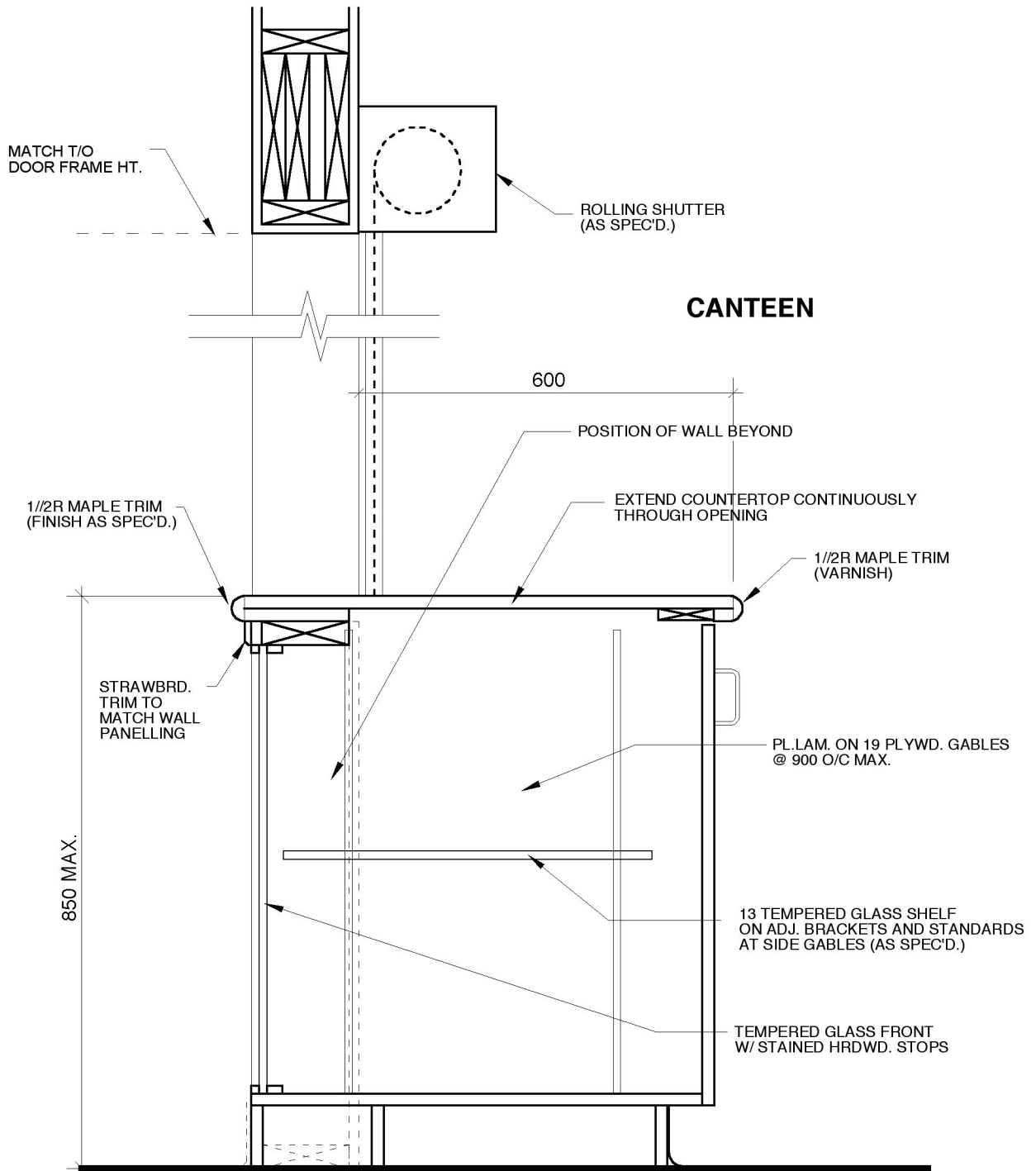

REFER TO SPECIFICATIONS FOR HARDWARE & FINISH SCHEDULES.
ENSURE BLOCKING IN WALL TO SECURE MILLWORK.

PRAIRIE
ARCHITECTS INC.

Project Title: RED RIVER COMMUNITY CENTRE
295 MURRAY AVENUE

Sheet Title: **MERCHANDISE DISPLAY CABINET**

200 -141 Bannatyne Avenue East
Winnipeg • Manitoba • R3B 0R3
(204) 956-0938

Proj. No: 2003.06
Scale: 1:10

Rev: **R-1**

Date: **March 23, 2005** Detail Sheet No. **DM-04**

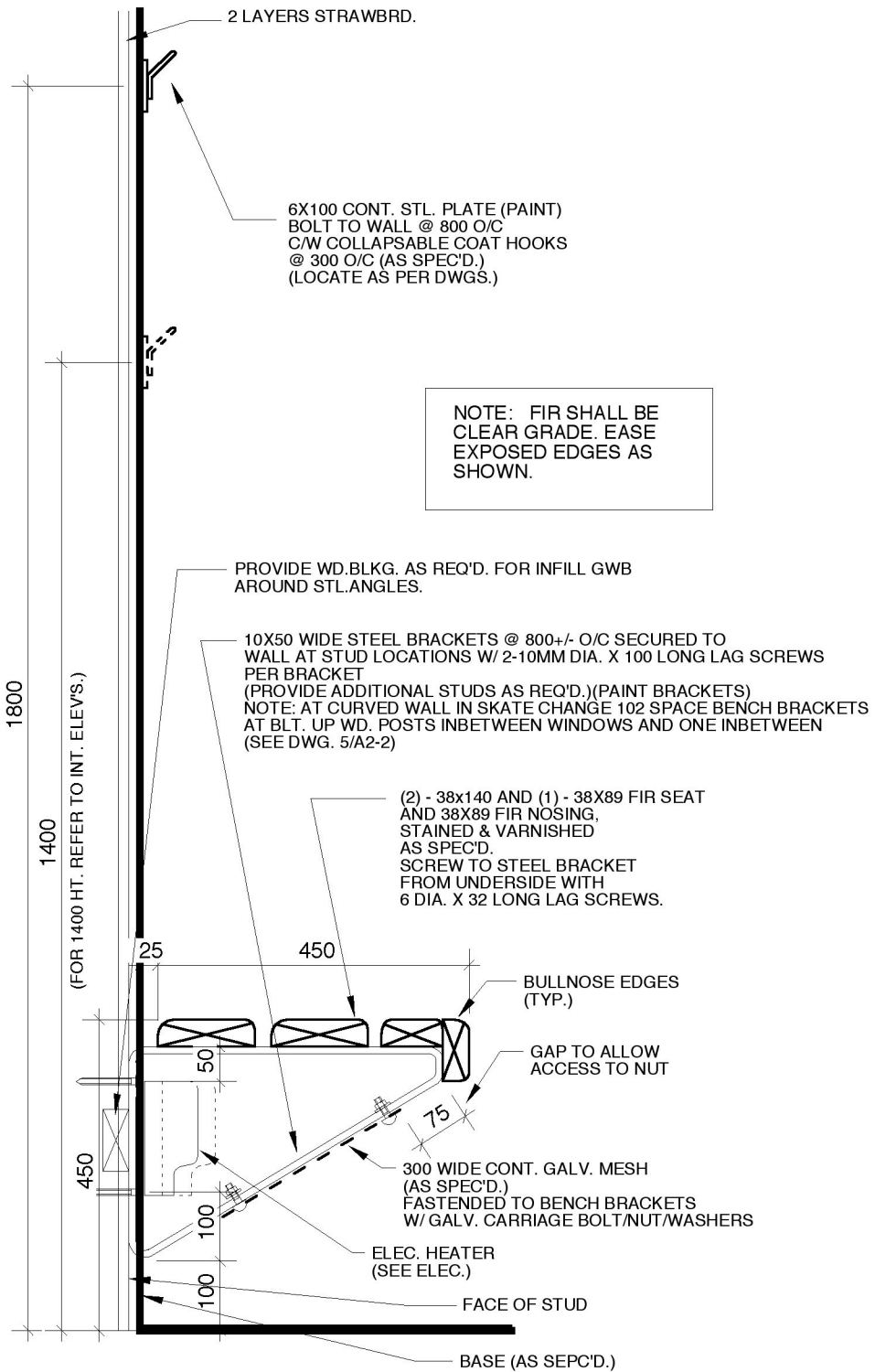

SECTION AT CHANGE ROOMS AND CORRIDOR 118 AND SKATE CHANGE 102

SCALE 1:10



Project Title: RED RIVER COMMUNITY CENTRE
293 MURRAY AVENUE

Sheet Title: **BENCH & HOOK DETAILS**

200 -141 Bannatyne Avenue East
Winnipeg • Manitoba • R3B 0R3
(204) 956-0938

Proj. No: 2003.06
Scale: **AS NOTED**

Date: **Dec. 22, 2004**

Detail Sheet No. **DM-05**

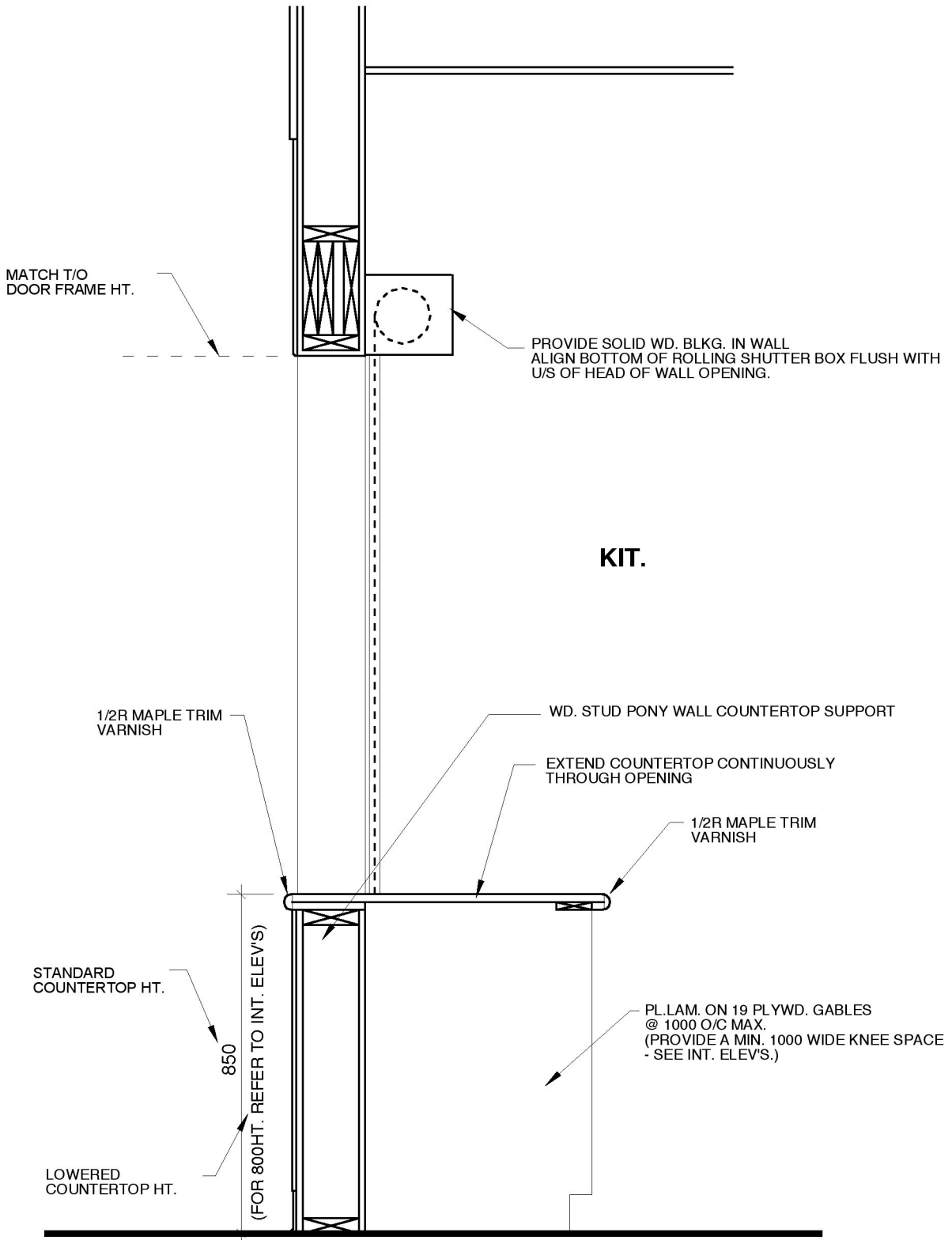

REFER TO SPECIFICATIONS FOR HARDWARE & FINISH SCHEDULES.
ENSURE BLOCKING IN WALL TO SECURE MILLWORK.

PRAIRIE
ARCHITECTS INC.

Project Title: RED RIVER COMMUNITY CENTRE
293 MURRAY AVENUE

Sheet Title: **COUNTER SHUTTER SECTION**

200 -141 Bannatyne Avenue East
Winnipeg • Manitoba • R3B 0R3
(204) 956-0938

Proj. No: 2003.06
Scale: 1:15

Rev: **R-1**
Date: **March 23, 2005**

Detail Sheet No. **DM-06**

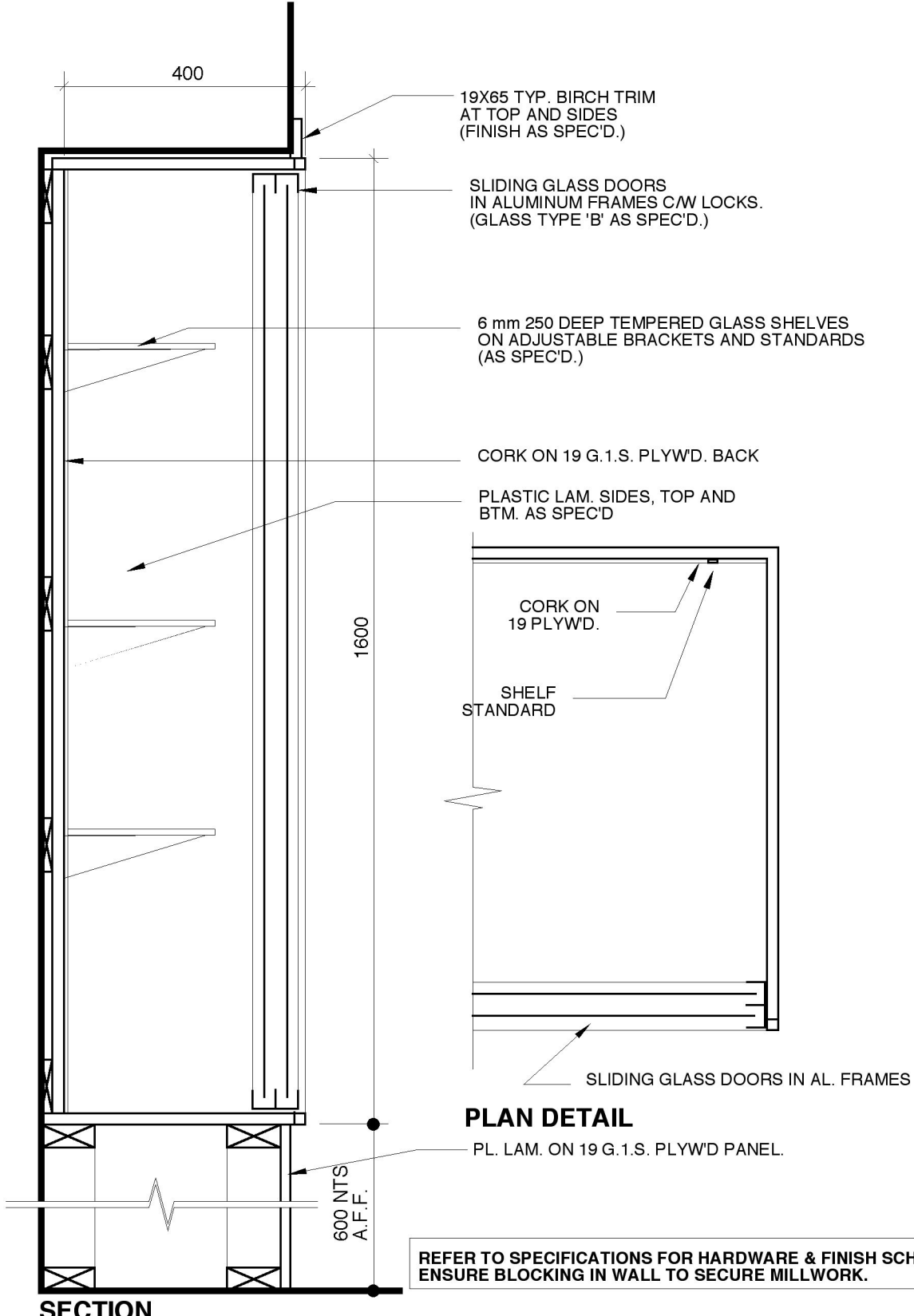

REFER TO SPECIFICATIONS FOR HARDWARE & FINISH SCHEDULES.
ENSURE BLOCKING IN WALL TO SECURE MILLWORK.



200 -141 Bannatyne Avenue East
Winnipeg • Manitoba • R3B 0R3
(204) 956-0938

Project Title: RED RIVER COMMUNITY CENTRE
293 MURRAY AVENUE

Sheet Title: **DISPLAY CASE**

Proj. No: 2003.06
Scale: 1 : 10

Rev: **R-1**

Date: **March 23, 2005** Detail Sheet No. **DM-07**

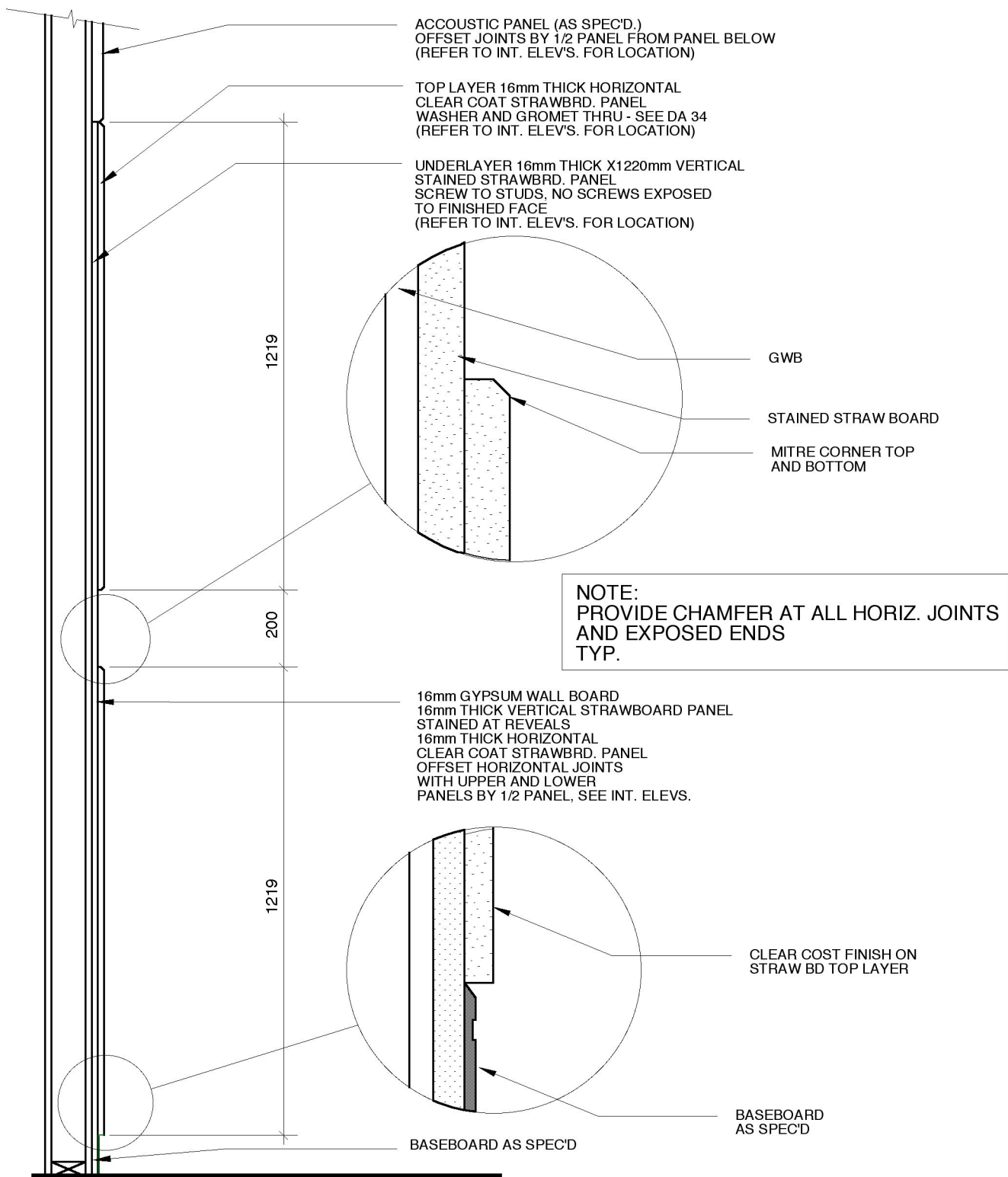

SECTION

REFER TO SPECIFICATIONS FOR HARDWARE & FINISH SCHEDULES.
ENSURE BLOCKING IN WALL TO SECURE MILLWORK.



Project Title: RED RIVER COMMUNITY CENTRE
293 MURRAY AVENUE

Sheet Title: **STRAWBOARD PANELING DETAIL**

200 -141 Bannatyne Avenue East
Winnipeg • Manitoba • R3B 0R3
(204) 956-0938

Proj. No: 2003.06
Scale: 1 : 15

Rev: R-1

Date: March, 23, 2005 Detail Sheet No.

DM-08

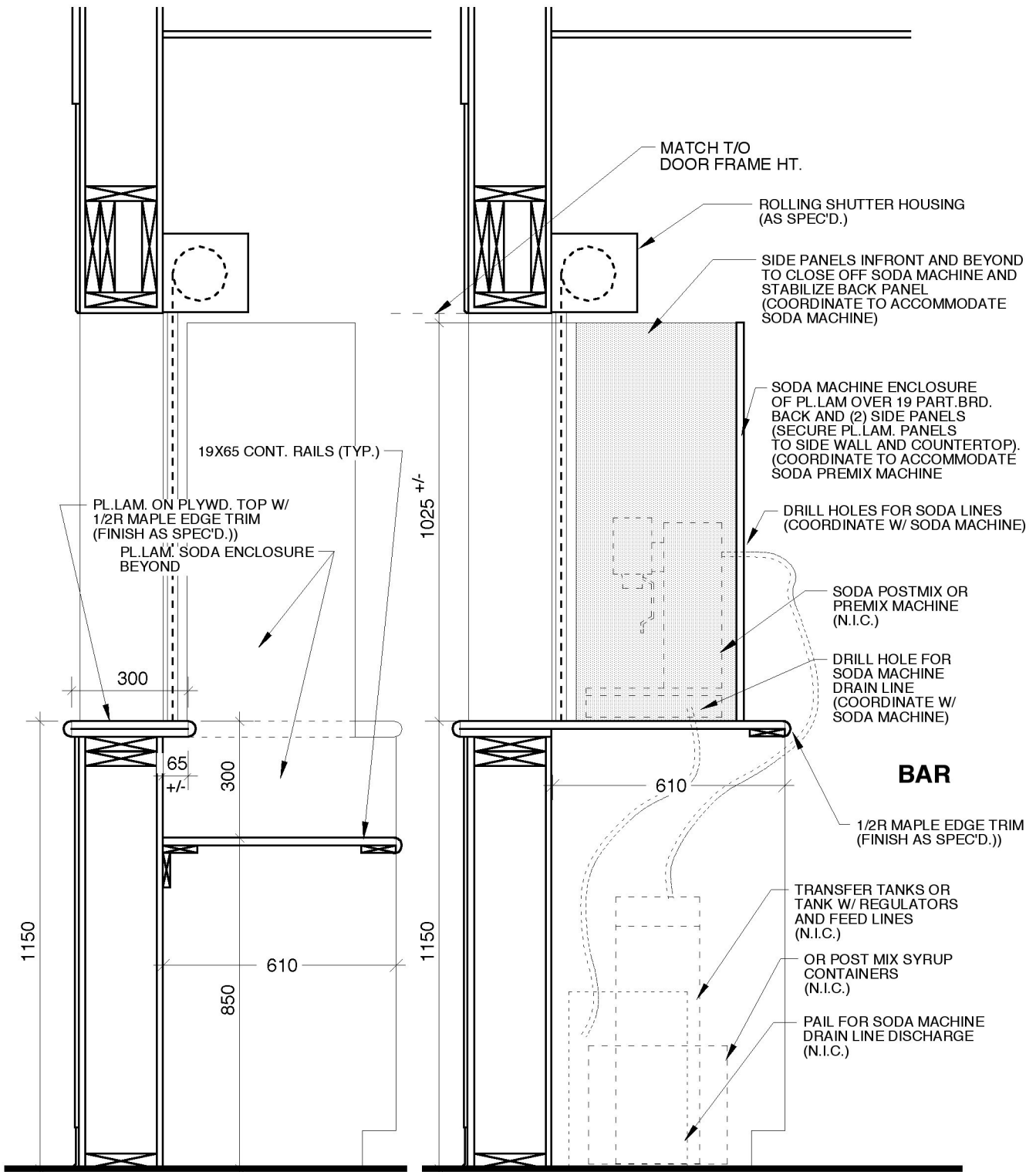

SECTION AT BAR

SECTION AT SODA MACHINE

REFER TO SPECIFICATIONS FOR HARDWARE & FINISH SCHEDULES.
ENSURE BLOCKING IN WALL TO SECURE MILLWORK.



Project Title: RED RIVER COMMUNITY CENTRE
293 MURRAY AVENUE

Sheet Title: **SODA MACHINE ENCLOSURE**

200 -141 Bannatyne Avenue East
Winnipeg • Manitoba • R3B 0R3
(204) 956-0938

Proj. No: 2003.06
Scale: 1:15

Rev: **R-1**

Date: **March 23, 2005** Detail Sheet No. **DM-09**

Part 1 - General

1.01 EXAMINATION

- .1 The Bidder, either personally or through a representative, shall examine the place of Work before submitting a Bid, and shall satisfy himself as to the nature and location of the Work and local conditions at the site of the Work, the equipment and facilities needed preliminary to and during the execution of the Work, the means of access to the site, onsite accommodation, all necessary information as to risks, contingencies and circumstances which may affect this Bid, and all other matters which can in any way affect the Work. The Bidder is fully responsible for obtaining all information required for the preparation of the Bid.
- .2 Claims for additional costs will not be entertained with respect to conditions which would reasonably have been ascertained by an inspection of the site prior to the Bid closing date.
- .3 The project is open for inspections by Bidders and sub trades at any time.

1.02 SITE SURVEY

- .1 Site Survey information is shown on sheet C-01.

1.03 SOILS REPORT

- .1 A soils report, prepared by M Block and Associates, dated February 12, 2004 forms part of this Section.



M. BLOCK & ASSOCIATES LTD.

Consulting Engineers

CSA CERTIFIED CONCRETE LABORATORY

T"01



■ Geotechnical Investigations ■ Environmental Assessments ■ C.S.A. Certified Materials Testing

February 12, 2004

Prairie Architects Inc.
200 – 141 Bannatyne Avenue
Winnipeg, Manitoba
R3B 0R3

Attention: Mr. Glen R. Klym, B.E.S. M. Arch. MRAIC

Dear Sir:

**RE: GEOTECHNICAL INVESTIGATION FOR THE PROPOSED RED RIVER
COMMUNITY CENTRE REDEVELOPMENT PROJECT – PROJECT FILE NO. 2002-266**

1.0 TERMS OF REFERENCE

On March 3, 2003, M. Block & Associates Ltd. (MBA) received written authorization from Mr. Glen Klym, B.E.S. M. Arch. MRAIC, representing Prairie Architects Inc., the project's architectural consultant, to proceed with the geotechnical investigation for the proposed Red River Community Centre Redevelopment Project in Winnipeg, Manitoba. Therefore, on February 4th and 5th, 2004, six test holes in total were bored implementing a track-mounted SoilMec piling rig, using a 24" diameter flight auger connected to a telescopic Kelly bar, supplied by Subterranean (Manitoba) Ltd. of Winnipeg, Manitoba. Representative "undisturbed" and "disturbed" soil samples were retrieved from those test holes and brought back to MBA's CSA certified materials testing laboratory in Winnipeg for unconfined compression and moisture content testing and verification of the field soil classifications, respectively. Alternatively, upon the completion of this investigation, the test holes' elevations and the groundwater elevations in the test holes, if any, were measured and referenced to their respective surfaces and the top of the first fire hydrant situated west of Main Street and located adjacent to the investigated site on the south side of Ridgcrest Avenue. In addition, the test holes were backfilled with soil cuttings.

*Geotechnical investigation for the proposed Red River
Community Centre Redevelopment Project in Winnipeg, Manitoba*

2.0 SOIL LITHOLOGY AND GROUNDWATER CONDITIONS

The test holes were overlain with up to 3'6" of black and brown frozen silty clay fill. Black, becoming brown with increasing depth, firm to stiff silty clay was then traversed in all the test holes. A brown soft saturated sandy silt layer, that, only, slightly sloughed and seeped into the deep test holes, was next recorded. Brown stiff silty clay with silt inclusions, that became firm in stiffness and grey in colour with increasing depth, was then noted in all the deep test holes. Next, in, only, test holes #1 and #2, brown soft saturated compact sandy clayey silt with cobbles and boulders (glacial till) was observed down to the 62' depth. Brown compact to very dense, practically non-plastic, sandy silt with cobbles and boulders (glacial till), that varied in stiffness and relative moisture content from soft and saturated to hard and dry, respectively, was then traversed in, only, test holes #2 and #3 down to the 66' and 62' depths, respectively, where test hole #2 refused. Finally, in, only, test holes #1 and #3, grey saturated dense poorly graded gravelly sand was recorded down auger refusal at the 66' depth. As such, those test holes were terminated at the aforementioned depth. Alternatively, probe holes were discontinued at the 6' depth. At the completion of this investigation, groundwater, emanating from the saturated gravelly sand stratum, possibly also an aquifer overlying fractured limestone bedrock, flowed into the deep test holes at very high inflow rates. Furthermore, within fifteen minutes of obtaining auger refusal, the groundwater elevations in test holes #1, #2 and #3 was measured as high as, approximately, 25' below their respective current ground elevations. In addition, during this investigation, groundwater seepage and soil sloughing, emanating from the saturated sandy silt layer's and the saturated fine-grained glacial till matrices' respective aquifers, flowed and caved into the deep test holes at, only, minimal inflow rates. The soil lithology in the test holes and their specific locations were appended to this report on pages 14 - 23.

Geotechnical investigation for the proposed Red River
Community Centre Redevelopment Project in Winnipeg, Manitoba

3.0 SUMMARY OF FIELD AND LABORATORY TESTS

| <u>TH#</u> | <u>DEPTH</u> | <u>UNCONFINED COMPRESSION</u> | <u>BULK UNIT WEIGHT</u> | <u>MOISTURE CONTENT</u> |
|------------|--------------|-----------------------------------|-----------------------------|-----------------------------|
| 1 | 11' | 1019 psf | 105.44 pcf | 57.25 % |
| 1 | 21' | 2334 psf | 106.66 pcf | 51.05 % |
| 1 | 31' | 2656 psf | 109.89 pcf | 46.73 % |
| 1 | 41' | 2646 psf | 113.57 pcf | 42.37 % |
| 1 | 51' | 1931 psf | 107.02 pcf | 52.13 % |

The unconfined compressive strengths are also located on the test hole's log sheet. Moisture connect vs. Depth graphs are located on the test holes' log sheets. A summary of the laboratory data are also appended to this report on pages 25 -26.

4.0 FOUNDATION DESIGN ALTERNATIVES

4.1 CONCRETE FOOTINGS

Predicated upon the well-documented volumetrically sensitive glaciolacustrine silty clay deposition in the former Lake Agassiz, that have caused significant structural distresses in typical below grade footings in similarly constructed structures in this area and the glaciolacustrine deposition's stiff unconfined compressive strength, its extremely high estimated liquid limit and plasticity index, and "near normal" moisture content at this site, it is the writer's professional opinion that a reinforced concrete footing foundation system, constructed on the glaciolacustrine soil located at this property, is exceptionally susceptible to severe soil swelling, shrinkage and/or rebound, and, as such, strongly not recommended as a feasible foundation system for this project.

4.2 DRILLED CAST IN PLACE CONCRETE FRICTION PILES

Depending on the applied axial compressive column loads of the proposed structure, drilled cast in place concrete friction piles, possibly placed in clusters underlying pile caps, could potentially be implemented as the foundation design for the proposed structure. Predicated upon the soft saturated sandy silt layer recorded in test hole #3 down to the 11'

**Geotechnical investigation for the proposed Red River
Community Centre Redevelopment Project in Winnipeg, Manitoba**

depth and the strong probability of basal instability occurring in this foundation type below the 52' depth, the allowable effective friction length of silty clay at this site is **52' - 11' = 41' from present grade**. The laboratory data indicates that the allowable average skin friction of the soil / concrete interface from the 11' to 52' depths is 375 psf. Based upon these calculations, a 16" diameter friction pile drilled 52' deep, properly constructed, would safely transfer 61 kips of load down to the underlying glaciolacustrine deposition. The concrete, relative to the soil, has an additional net weight of approximately, 40 pounds per cubic foot. Therefore, the additional net weight of the concrete is included in the above analysis. In addition, in order to avoid reducing the piles' net efficiency, they must be spaced at least three pile diameters, on centre. In order to resist potential soil swelling and frost jacking uplift stresses, these piles shall also have a minimum embedment length of 25'.

It is recommended that the geotechnical engineer's personnel inspect the installation of this foundation type in order to verify that it conforms to the contents of this report, the structural drawings and project's specifications.

The foundation contractor shall be fully cognizant that the alluvially deposited sandy silt stratum may slough and seep into some or several of the piles' excavations during wetter seasons and/or years. Therefore, should that situation transpire, steel casing through that entire stratum would then be required. Since soil sloughing during concreting may cause improper foundation performance, special care must be given when removing the steel sleeve not to cause sloughing soil from entering a pile's excavation from in behind it. As such, the foundation contractor shall be diligent when removing the steel sleeve not to cause sloughing soil from entering the pile's excavation from in behind it. In addition, the top 7' of embedment length in every concrete pile shall be mechanically vibrated.

The advantages of this piling system are its relatively fast rate of pile installation, frequency of being more economical than other piled foundation designs in the Winnipeg area, efficiency of installation in comparison with an end-bearing driven pre-cast concrete

**Geotechnical investigation for the proposed Red River
Community Centre Redevelopment Project in Winnipeg, Manitoba**

pile foundation system, the many piling businesses located in the vicinity and minimal amount of modeled long-term foundation settlement. The disadvantages of this piling system are the limited depth of effective silty clay and pile capacity on this site, the extra cost associated with steel sleeving, if required, and the potential for pile settlement, if constructed improperly.

4.3 DRIVEN PRE-CAST CONCRETE PILES

Driven pre-cast concrete piles could also be implemented as the foundation design for the proposed structure. Predicated upon the proposed structure's proximity to the neighboring houses, all pre-cast concrete piles shall be pre-drilled at least 4.5 m deep and then driven to refusal onto a dense stratum, such as, the hard glacial till matrix or a dense granular stratum. The estimated length of properly driven pre-cast concrete piles required at this location would be **in the order of 20.1 m from present ground elevation.** However, the foundation contractor shall still verify the estimated length of pre-cast concrete piles required at this site and become fully cognizant with the contents of this report. Following their successful installation, all the piles' oversized pre-bores shall then be backfilled with clean sand in order to maximize their lateral support and minimize their frictional capacity and bond with underlying volumetrically sensitive glaciolacustrine silty clay. The geotechnical engineer's personnel shall inspect the foundation installation to verify the piles' respective capacities based upon the following pile driving criteria.

| PILE DIAMETER | DRIVING ENERGY | REFUSAL CRITERIA | CAPACITY |
|----------------------|-----------------------|-------------------------|-----------------|
| 305 mm | 30 foot * kips | 5 blows / 1" (25 mm) | 50 tons |
| 350 mm | 30 foot * kips | 10 blows / 1" (25 mm) | 70 tons |
| 400 mm | 30 foot * kips | 15 blows / 1" (25 mm) | 90 tons |

Note: Max 1" (25mm) penetration per set, for 3 consecutive sets

**Geotechnical investigation for the proposed Red River
Community Centre Redevelopment Project in Winnipeg, Manitoba**

In addition to the aforementioned specifications for driven pre-cast concrete piles, MBA offers the following recommendations:

- Pre-drilling through the zone of frost may be required for winter or early spring construction.
- If a drop hammer is to be used to install these piles, the mass of the hammer shall be 3 times greater than the mass of the pile.
- Pile spacing shall not be less than three pile diameters, on centre.
- Piles driven within five pile diameters, on centre, shall be monitored for heave and where it is observed; the piles shall be re-driven to the aforementioned refusal criteria.
- Once pile driving is initiated, all piles shall be driven continuously to their respective refusal depth.

The advantages of this piling system are its heavy axial compressive capacities and minimal amount of modeled long-term foundation settlement. The disadvantages of this piling system are its frequently greater cost per foot of pile and the variable depth to practical pile refusal.

5.0 CONCRETE DESIGN

Due to the large concentration of sulphate in the glaciolacustrine deposition at this site, Sulphate Resisting Cement shall be used in all the concrete implemented for the aforementioned concrete piled foundation systems. Its concrete shall have a minimum 28-Day laboratory compressive strength of 32 MPa. Furthermore, the concrete shall contain at least 550 pounds of cement per cubic yard, have a maximum water cement ratio, a plastic concrete air content and slump of 0.45, 4 to 6 percent and 60 mm to 100 mm, respectively.

Alternatively, due to the higher elevation of the proposed concrete floor slab in relation to the elevations of these test holes and the low concentration of sulphate in the alluvially

**Geotechnical investigation for the proposed Red River
Community Centre Redevelopment Project in Winnipeg, Manitoba**

deposited surface silty clay layer traversed across this site, Normal Portland Cement could be used in all the concrete implemented for the structure's grade beams and its floor slab.

All other concrete exposed to freezing and thawing cycles shall contain an air entraining admixture that supplies an air content of 4%-7%. Concrete poured in cold weather shall be heated and protected in accordance with CSA A23.1-00 clause 21.2.3.

In addition, all concrete poured shall be tested in accordance with CSA A23.1-00 every day and at least once every 50 m³ per day by a CSA certified concrete testing laboratory.

6.0 SURFACE SLAB ON GRADE CONCRETE FLOOR SLAB DESIGN

All the deleterious fill, vegetation and organic topsoil shall be stripped and transported off of the site. In addition, the remaining soil located above the project's working sub-grade elevation, if any, shall also be excavated and transported off of the site. Prior to placing the proposed concrete floor slab's granular base structure, the in-situ silty clay fill, with a low plasticity index, located at the working sub-grade elevation shall then be proof-rolled by a heavy sheepsfoot roller until it has at least 98 % of its standard proctor density. Areas failing the aforementioned proof-roll test and any other deleterious material encountered at the working sub-grade elevation shall be verified and documented by the geotechnical engineer's personnel. The project's slab on grade sub-contractor shall then excavate and replace the documented failed proof-rolled soil and the other deleterious material encountered at the working sub-grade elevation with 50 mm down crushed limestone fill or an equivalent pre-approved bridging material placed in sufficient 200 mm deep lifts and compacted until each layer has at least 98 % of its standard proctor density.

Next, any areas of the building's footprint naturally lower than the proposed sub-grade elevation, if any, shall then be brought up to the sub-grade elevation implementing either a 50 mm down crushed limestone fill, granular C-Base fill or another pre-approved equivalent

**Geotechnical investigation for the proposed Red River
Community Centre Redevelopment Project in Winnipeg, Manitoba**

bridging material, placed in sufficient 200 mm deep lifts and compacted until each layer has at least 98 % of its standard proctor density.

In order to raise the proposed slab on grade up to the underside of the granular base course elevation, at least one lift of C-Base, 50 mm down crushed limestone fill or an equivalent approved material shall be placed in a 150 mm deep layer and compacted until every lift has at least 98 % of its standard proctor density. Finally, the granular base course, composed of a 150 mm deep lift of A-Base, shall be placed and compacted until it has at least 100 % of its standard proctor density. The concrete slab shall then be poured having a slump in the range of 70 mm to 100 mm. The concrete shall have a maximum water cement ratio of 0.45 and contain a water reducing admixture.

However, if the structural engineer or owner cannot accept the possibility of differential slab displacement of up to 40 mm, then a structurally supported concrete floor slab shall be implemented for this project.

7.0 PAVEMENT DESIGN

The working sub-grade elevations in the areas designated for heavy truck traffic, light truck traffic and the exterior sidewalks' concrete slab shall be situated 564 mm, 376 mm and 600 mm below the their future grades, respectively.

All the deleterious fill, vegetation and organic topsoil shall be stripped and transported off of the site. In addition, the remaining soil located above the project's working sub-grade elevation, if any, shall also be excavated and transported off of the site. Prior to placing the proposed pavement structures' granular base courses, the in-situ silty clay fill, with a low plasticity index, located at the working sub-grade elevation shall then be proof-rolled by a heavy sheepsfoot roller until it has at least 98 % of its standard proctor density. Areas failing the aforementioned proof-roll test and any other deleterious material encountered at the working sub-grade elevation shall be verified and documented by the geotechnical

**Geotechnical investigation for the proposed Red River
Community Centre Redevelopment Project in Winnipeg, Manitoba**

engineer's personnel. The project's pavement sub-contractor shall then excavate and replace the documented failed proof-rolled soil and the other deleterious material encountered at the working sub-grade elevation with 50 mm down crushed limestone fill or an equivalent pre-approved bridging material placed in sufficient 200 mm deep lifts and compacted until each layer has at least 98 % of its standard proctor density.

Next, any segments of the proposed pavement areas naturally lower than the proposed sub-grade elevation, if any, shall then be brought up to the sub-grade elevation implementing either a highly plastic silty clay fill, 50 mm down crushed limestone fill, granular C-Base fill or another pre-approved equivalent bridging material, placed in sufficient 200 mm deep lifts and compacted until each layer has at least 98 % of its standard proctor density.

In order to provide adequate structural support in areas designated for heavy truck traffic and the concrete sidewalks, their sub-bases shall consist of at least two layers of C-Base or 50 mm down crushed limestone fill placed in 150 mm deep lifts and compacted until each layer has at least 98 % of its standard proctor density. However, only one lift of granular sub-base is structurally required for the light car traffic's pavement construction. Next, in all traffic areas, the granular base course, composed of a 150 mm deep lift of A-Base, shall be placed and compacted until it has at least 100 % of its standard proctor density. Finally, the light car traffic's asphalt pavement shall be laid in two layers with each lift having a minimum thickness of 38 mm. Areas with heavier truck traffic shall have three - 38 mm lifts of asphalt pavement. Each asphalt pavement area shall be consolidated until it has at least 98 % of its respective laboratory Marshall Density. An elevation view of the car and heavy truck traffic's respective pavement structures is illustrated on page 24 of this report.

The sidewalks shall have a concrete design thickness of 150 mm, overlying its aforementioned granular base's structural support, and an air-entrainment, slump and water cement ratio in accordance with all the relevant CSA standards in A23.1-00.

**Geotechnical investigation for the proposed Red River
Community Centre Redevelopment Project in Winnipeg, Manitoba**

The asphalt aggregate shall have a crushed count of >60%. The asphalt shall be placed at a temperature of 125°C to 155°C. The ambient temperature may be no less than 6°C when the asphalt is to be laid. The geotechnical engineer's personnel shall test the asphalt for the following properties.

The aggregate to be used for the asphalt pavement should be within the following gradation limits and physical properties:

| METRIC SIEVE SIZE (microns) | (% Passing) |
|-----------------------------|-------------|
| 16,000 | 100 |
| 10,000 | 70 – 85 |
| 5,000 | 55 – 70 |
| 2,500 | 40 – 60 |
| 1,250 | 25 – 50 |
| 630 | 15 – 40 |
| 315 | 5 – 20 |
| 160 | 4 – 11 |
| 80 | 3 – 7 |

| | |
|---------------------------------------|---------------|
| Asphalt Cement, % total sample weight | 5.0 % - 6.0 % |
| Voids in Mineral Aggregate | 14% minimum |
| Air Voids | 3.0% - 5.0% |
| Marshall Stability, N at 60° C | 7 kN minimum |
| Flow Index, units of 250 µm | 6.0 – 16.0 |

The pavement shall be sufficiently sloped for expedient drainage into catch basins or towards the perimeter of the property.

8.0 RECOMMENDATIONS

Predicated upon the soils' aforementioned respective strength parameters, lithology and physical properties, the current groundwater elevations, the field and laboratory test data, and the proposed structure's anticipated applied foundation stresses, drilled cast in place concrete friction piles or end-bearing driven pre-cast concrete piles could be implemented as the foundation design for the proposed structure. Based upon the aforementioned advantages and disadvantages of these foundation systems, a drilled cast in place concrete friction piled foundation design would likely be the best performing, economical and efficient one for the proposed moderately-loaded wood-framed structure, placed on a

**Geotechnical investigation for the proposed Red River
Community Centre Redevelopment Project in Winnipeg, Manitoba**

property with the aforementioned geotechnical design parameters. However, the choice of foundation type implemented for this structure will ultimately depend upon their respective economics, previously described advantages and disadvantages and the foundation loads that will be calculated by the structural engineer.

It is recommended that the geotechnical engineer's personnel inspect the installation of all the foundation elements in order to verify that they all conform to the contents of this report, the structural drawings and the project's specifications.

In order to minimize frost penetration under the structure, 50 mm thick rigid horizontal insulation, or equivalent frost protection, shall be placed around the exterior of the entire structure. This insulation shall be placed along the face of the proposed structure out to a distance 1200 mm away from it at a depth of 300 mm below future ground elevation.

The selected A-base and C-base gravels implemented for this project shall meet the following gradation specifications:

| METRIC SIEVE SIZE (μm) | A-BASE (% Passing) | C-BASE (% Passing) |
|--|-----------------------|-----------------------|
| 25,000 | 100 | 100 |
| 20,000 | 80 – 100 | |
| 5,000 | 40 – 70 | 25 – 80 |
| 2,500 | 25 – 55 | |
| 315 | 15 – 30 | |
| 80 | 5 – 15 | 5 – 18 |

The proposed surface concrete slab on grade and asphalt pavement shall be constructed as per the recommendations outlined in sections 6.0 and 7.0 of this report, respectively. If the owner or structural engineer cannot accept the possibility of the aforementioned differential slab on grade displacement, then a structurally supported floor slab shall be implemented. In order to verify compliance with the aforementioned standard proctor and

*Geotechnical investigation for the proposed Red River
Community Centre Redevelopment Project in Winnipeg, Manitoba*

Marshall Density specifications, field compaction tests shall be taken on every lift of granular material and asphalt placed for this project, respectively. All concrete poured shall be tested in accordance with CSA A23.1-00 every day and at least once every 50 m³ per day by a CSA Certified concrete testing laboratory.

The writer was informed that a basement is not intended for the proposed structure.

Any play areas naturally lower in elevation, if any, shall be brought up to the field's future grade implementing a highly plastic silty clay fill, 50 mm down crushed limestone fill, granular C-Base fill or an equivalent bridging material, placed in sufficient 200 mm deep lifts and compacted until each layer has at least 98 % of its standard proctor density.

If any of the aforementioned design elements are modified or deleted, please contact the undersigned to determine if that course of action will be acceptable.

In addition, MBA respectfully requests an opportunity to review all the relevant finalized structural drawings and the project's foundation and materials testing specifications for this project in order to verify their conformance with the contents of this report.

The test holes drilled during this investigation represent only those specific areas tested. The soil conditions on this site may vary from that described in this report. Should that situation occur, please contact this office for further instructions.

All the geotechnical engineering design recommendations presented in this report are predicated upon the assumption that a sufficient degree of inspection will be provided during the project's construction and that a qualified and experienced foundation contractor properly installs one of the aforementioned approved foundation types.

Any uses which a third party makes of this report, or any reliance on decisions to be made

based on it, are the sole responsibility of such third parties. MBA accepts no responsibility for damages, if any, suffered by any third party as a result of decisions made or actions based upon this report.

Yours Truly,
M. Block & Associates Ltd.



Jeffrey Block, P. Eng., Senior Geotechnical Engineer





M. Block & Associates Ltd.

2484 Ferrier Street
Winnipeg, Manitoba, R2V 4P6
Telephone: (204)-334-5356
Fax: (204)-339-7976

129 Grand Trunk Street
Dryden, Ontario P8N 2W4
Telephone: (807)-223-8384
Fax: (807)-223-8384

TEST HOLE NO.: 1
Sheet 1 of 2

| | | | |
|---|-------------------|--------------------------------|---------------|
| Client: Prairie Architects Inc. | Job No.: 405-2004 | Logged By: T. Gluck, EIT | Date: 4/2/04 |
| Project: Red River Community Centre Redevelopment | | Reviewed By: J. Block, P. Eng. | Time: 2:00 PM |
| Location: Main Street & Murray Avenue in Winnipeg | Elevation: 99.42m | Drawing Number: 5006 | |

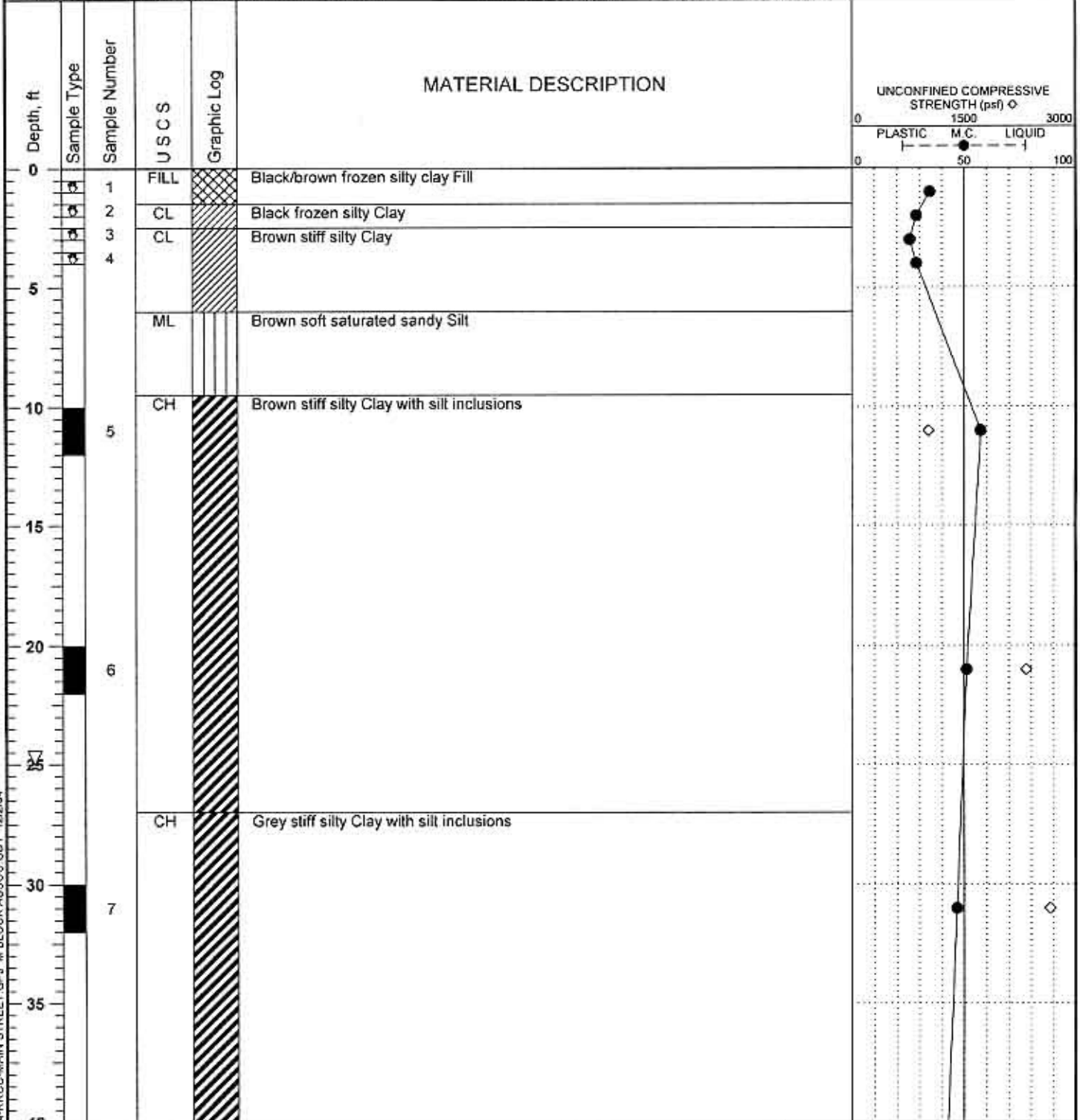

TEST HOLE LOG 405-2004-RRCC-MAIN STREET.GPJ M.BLOCK.ASSOC.GDT 12/2/04

SAMPLE TYPE SYMBOLS

- Split Spoon
- Vane Shear
- Grab Sample
- Shelby Tube
- Auger Cuttings
- Rock Core

Continued Next Page

WATER LEVELS

| | | | |
|-------------|------------------------------|-------------------------------|---------|
| Drill Rig: | Track Mounted SoilMec | ∇ Phreatic Surface #1: | 25.0 ft |
| Auger: | 24" dia. telescopic auger | | |
| Contractor: | Subterranean (Manitoba) Ltd. | | |



M. Block & Associates Ltd.

2484 Ferrier Street
Winnipeg, Manitoba, R2V 4P6
Telephone: (204)-334-5356
Fax: (204)-339-7976

129 Grand Trunk Street
Dryden, Ontario P8N 2W4
Telephone: (807)-223-8384
Fax: (807)-223-8384

TEST HOLE NO.: 1
Sheet 2 of 2

| | | | |
|---|-------------------|--------------------------------|---------------|
| Client: Prairie Architects Inc. | Job No.: 405-2004 | Logged By: T. Gluck, EIT | Date: 4/2/04 |
| Project: Red River Community Centre Redevelopment | | Reviewed By: J. Block, P. Eng. | Time: 2:00 PM |
| Location: Main Street & Murray Avenue in Winnipeg | Elevation: 99.42m | Drawing Number: 5006 | |

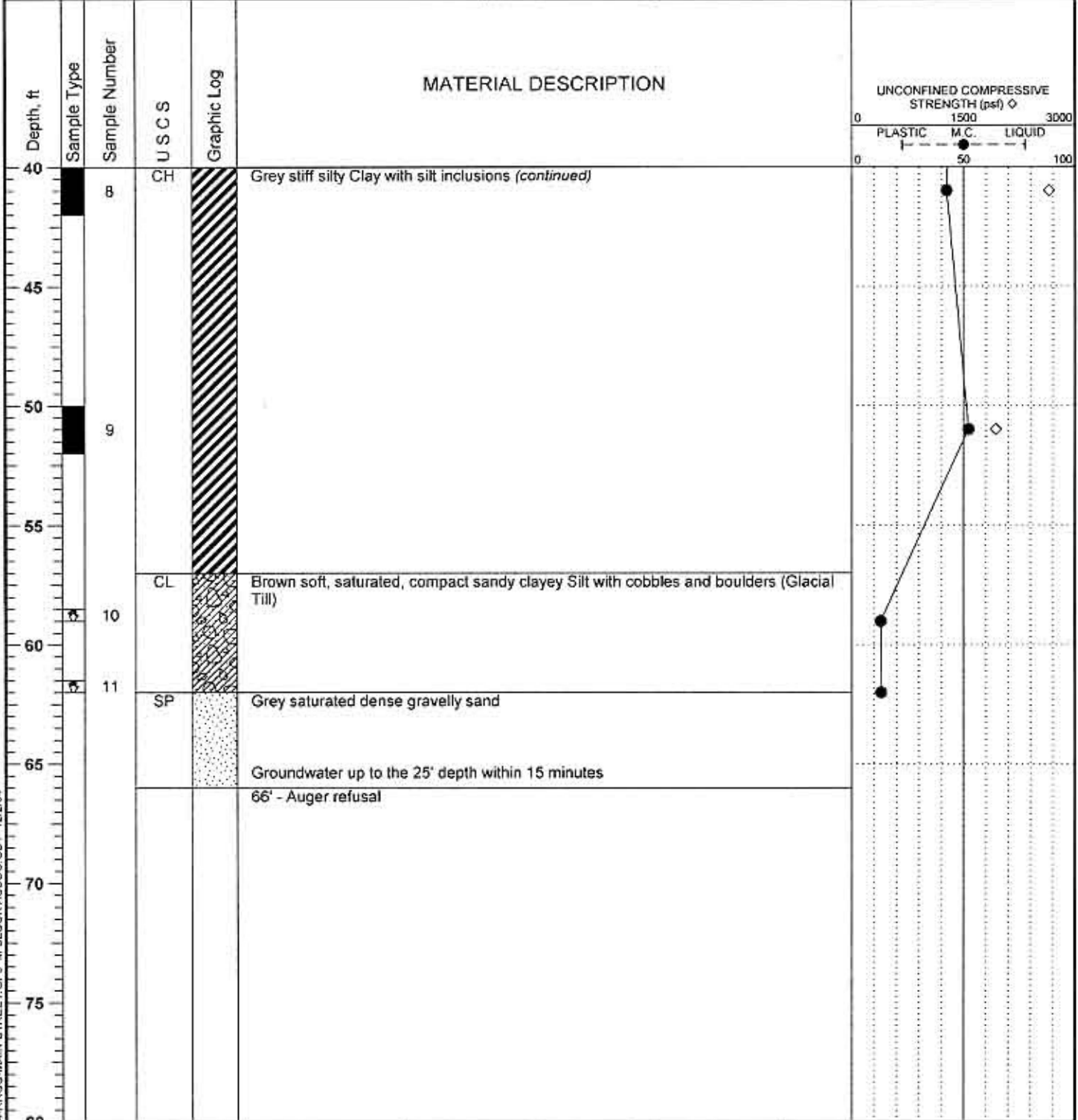

TEST HOLE LOG 405-2004-RRCC-MAIN STREET.GPJ M BLOCK ASSOC. GDT. 12/2/04

| SAMPLE TYPE SYMBOLS | |
|---------------------|----------------|
| | Split Spoon |
| | Shelby Tube |
| | Vane Shear |
| | Auger Cuttings |
| | Grab Sample |
| | Rock Core |

| WATER LEVELS | |
|----------------------|------------------------------|
| Drill Rig: | Track Mounted SoilMec |
| Auger: | 24" dia. telescopic auger |
| Contractor: | Subterranean (Manitoba) Ltd. |
| Phreatic Surface #1: | 25.0 ft |



M. Block & Associates Ltd.
 2484 Ferrier Street
 Winnipeg, Manitoba, R2V 4P6
 Telephone: (204)-334-5356
 Fax: (204)-339-7976

129 Grand Trunk Street
 Dryden, Ontario P8N 2W4
 Telephone: (807)-223-8384
 Fax: (807)-223-8384

TEST HOLE NO.: 2
 Sheet 1 of 2

| | | | |
|---|-------------------|--------------------------------|---------------|
| Client: Prairie Architects Inc. | Job No.: 405-2004 | Logged By: T. Gluck, EIT | Date: 5/2/04 |
| Project: Red River Community Centre Redevelopment | | Reviewed By: J. Block, P. Eng. | Time: 8:15 AM |
| Location: Main Street & Murray Avenue in Winnipeg | Elevation: 99.43m | Drawing Number: 5006 | |

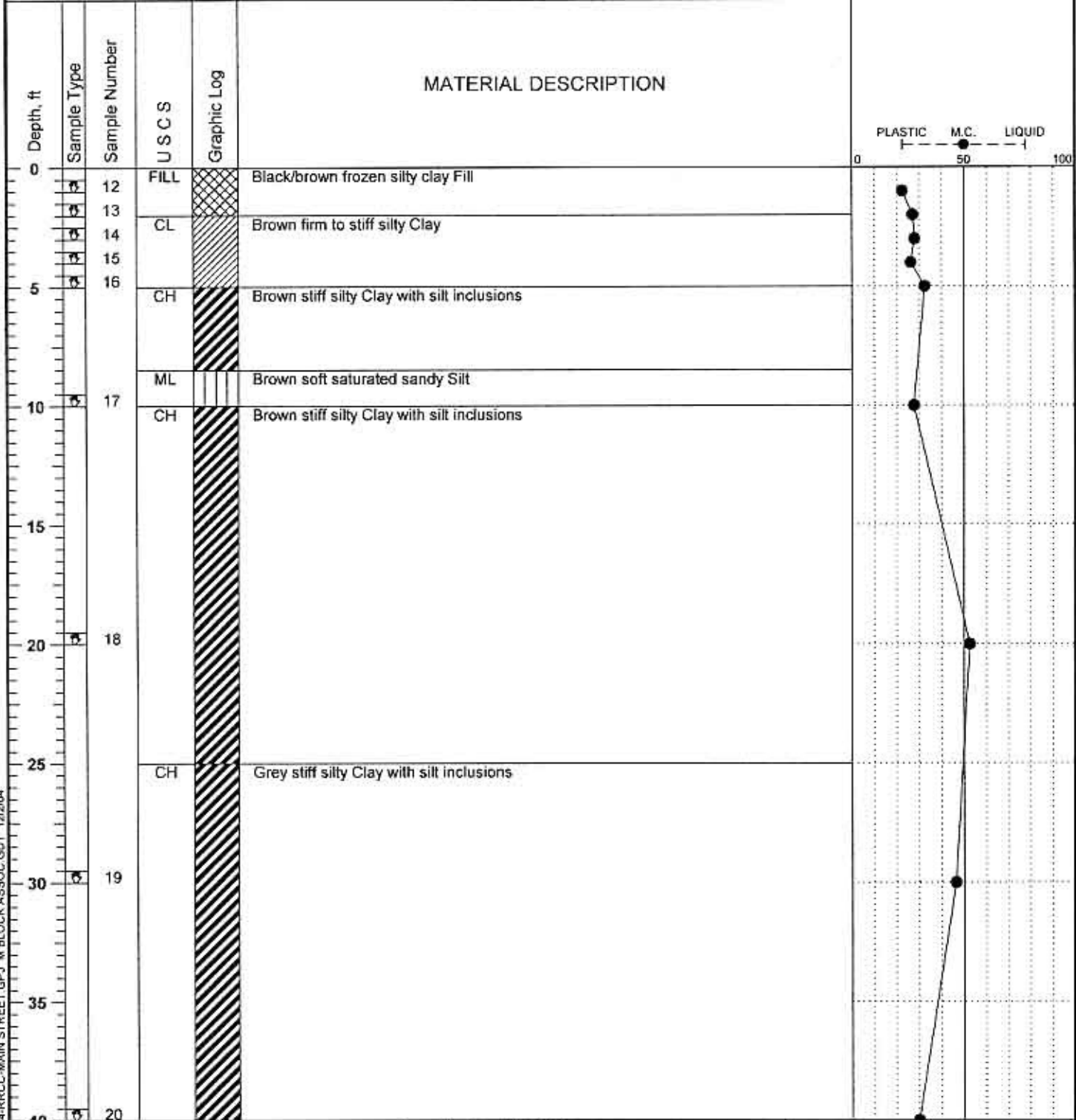

TEST HOLE LOG 405-2004-RRCC-MAIN STREET GPJ M BLOCK ASSOC.GDT 12/2/04

SAMPLE TYPE SYMBOLS

| | | | |
|--|-------------|--|----------------|
| | Split Spoon | | Shelby Tube |
| | Vane Shear | | Auger Cuttings |
| | Grab Sample | | Rock Core |

Continued Next Page

| | |
|-------------|------------------------------|
| Drill Rig: | Track Mounted SoilMec |
| Auger: | 24" dia. telescopic auger |
| Contractor: | Subterranean (Manitoba) Ltd. |

WATER LEVELS

| | |
|------------------------|---------|
| ∇ Phreatic Surface #1: | 56.0 ft |
|------------------------|---------|



M. Block & Associates Ltd.

2484 Ferrier Street
Winnipeg, Manitoba, R2V 4P6
Telephone: (204)-334-5356
Fax: (204)-339-7976

129 Grand Trunk Street
Dryden, Ontario P8N 2W4
Telephone: (807)-223-8384
Fax: (807)-223-8384

TEST HOLE NO.: 2
Sheet 2 of 2

| | | | |
|---|-------------------|--------------------------------|---------------|
| Client: Prairie Architects Inc. | Job No.: 405-2004 | Logged By: T. Gluck, EIT | Date: 5/2/04 |
| Project: Red River Community Centre Redevelopment | | Reviewed By: J. Block, P. Eng. | Time: 8:15 AM |
| Location: Main Street & Murray Avenue in Winnipeg | Elevation: 99.43m | Drawing Number: 5006 | |

| Depth, ft | Sample Type | Sample Number | USCS | Graphic Log | MATERIAL DESCRIPTION | PLASTIC | M.C. | LIQUID |
|-----------|-------------|---------------|-------|-------------|--|---------|------|--------|
| 40 | | | CH | | Grey stiff silty Clay with silt inclusions (continued) | 0 | 50 | 100 |
| 50 | | 21 | | | | | | |
| 60 | | 22 | CL | | Brown soft, saturated, compact sandy clayey Silt with cobbles and boulders (Glacial Till) | | | |
| 65 | | 23 | CL-ML | | Brown damp, very stiff, dense to very dense, practically non-plastic sandy Silt with cobbles and boulders (Glacial Till) | | | |
| 66 | | 24 | | | Groundwater up to the 56' depth after two minutes | | | |
| 66 | | | | | 66' - Hard in stiffness and auger refusal | | | |

TEST HOLE LOG 405-2004-RRCC-MAIN STREET.GPJ M BLOCK ASSOC GDT 12/2/04

SAMPLE TYPE SYMBOLS

| | | | |
|--|-------------|--|----------------|
| | Split Spoon | | Shelby Tube |
| | Vane Shear | | Auger Cuttings |
| | Grab Sample | | Rock Core |

WATER LEVELS

| | | | |
|-------------|------------------------------|----------------------|---------|
| Drill Rig: | Track Mounted SoilMec | Phreatic Surface #1: | 56.0 ft |
| Auger: | 24" dia. telescopic auger | | |
| Contractor: | Subterranean (Manitoba) Ltd. | | |



M. Block & Associates Ltd.

2484 Ferrier Street
Winnipeg, Manitoba, R2V 4P6
Telephone: (204)-334-5356
Fax: (204)-339-7976

129 Grand Trunk Street
Dryden, Ontario P8N 2W4
Telephone: (807)-223-8384
Fax: (807)-223-8384

TEST HOLE NO.: 3
Sheet 1 of 2

| | | | |
|---|-------------------|--------------------------------|---------------|
| Client: Prairie Architects Inc. | Job No.: 405-2004 | Logged By: T. Gluck, EIT | Date: 5/2/04 |
| Project: Red River Community Centre Redevelopment | | Reviewed By: J. Block, P. Eng. | Time: 9:00 AM |
| Location: Main Street & Murray Avenue in Winnipeg | Elevation: 99.35m | Drawing Number: 5006 | |

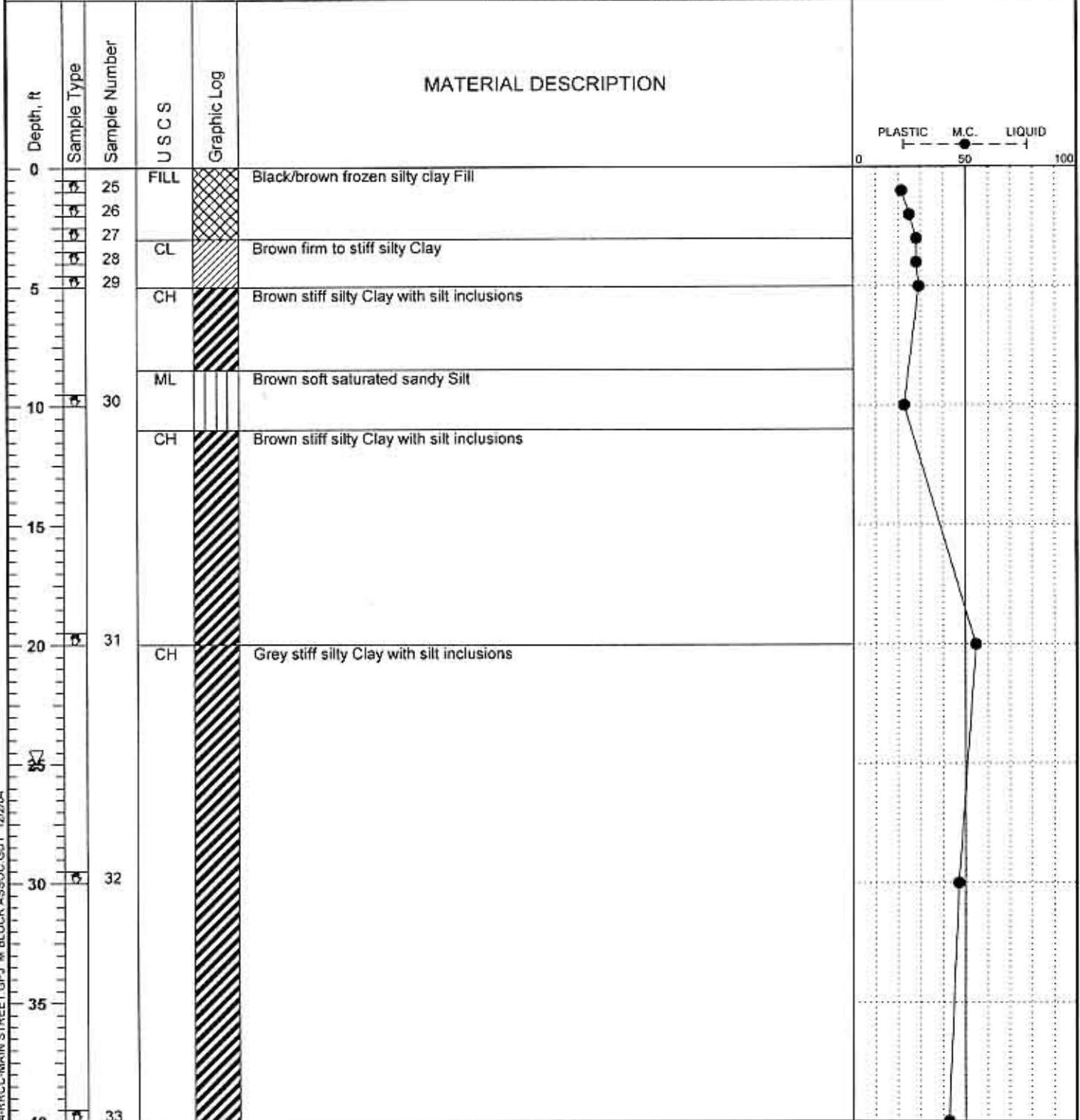

TEST HOLE LOG 405-2004-RRCC-MAIN STREET GP J M BLOCK ASSOC GDT 12/2/04

SAMPLE TYPE SYMBOLS

- Split Spoon
- Shelby Tube
- Vane Shear
- Auger Cuttings
- Grab Sample
- Rock Core

Continued Next Page

WATER LEVELS

| | | | |
|-------------|------------------------------|----------------------|---------|
| Drill Rig: | Track Mounted SoilMec | Phreatic Surface #1: | 25.0 ft |
| Auger: | 24" dia. telescopic auger | | |
| Contractor: | Subterranean (Manitoba) Ltd. | | |



M. Block & Associates Ltd.

2484 Ferrier Street
Winnipeg, Manitoba, R2V 4P6
Telephone: (204)-334-5356
Fax: (204)-339-7976

129 Grand Trunk Street
Dryden, Ontario P8N 2W4
Telephone: (807)-223-8384
Fax: (807)-223-8384

TEST HOLE NO.: 3
Sheet 2 of 2

| | | | |
|---|-------------------|--------------------------------|---------------|
| Client: Prairie Architects Inc. | Job No.: 405-2004 | Logged By: T. Gluck, EIT | Date: 5/2/04 |
| Project: Red River Community Centre Redevelopment | | Reviewed By: J. Block, P. Eng. | Time: 9:00 AM |
| Location: Main Street & Murray Avenue in Winnipeg | Elevation: 99.35m | Drawing Number: 5006 | |

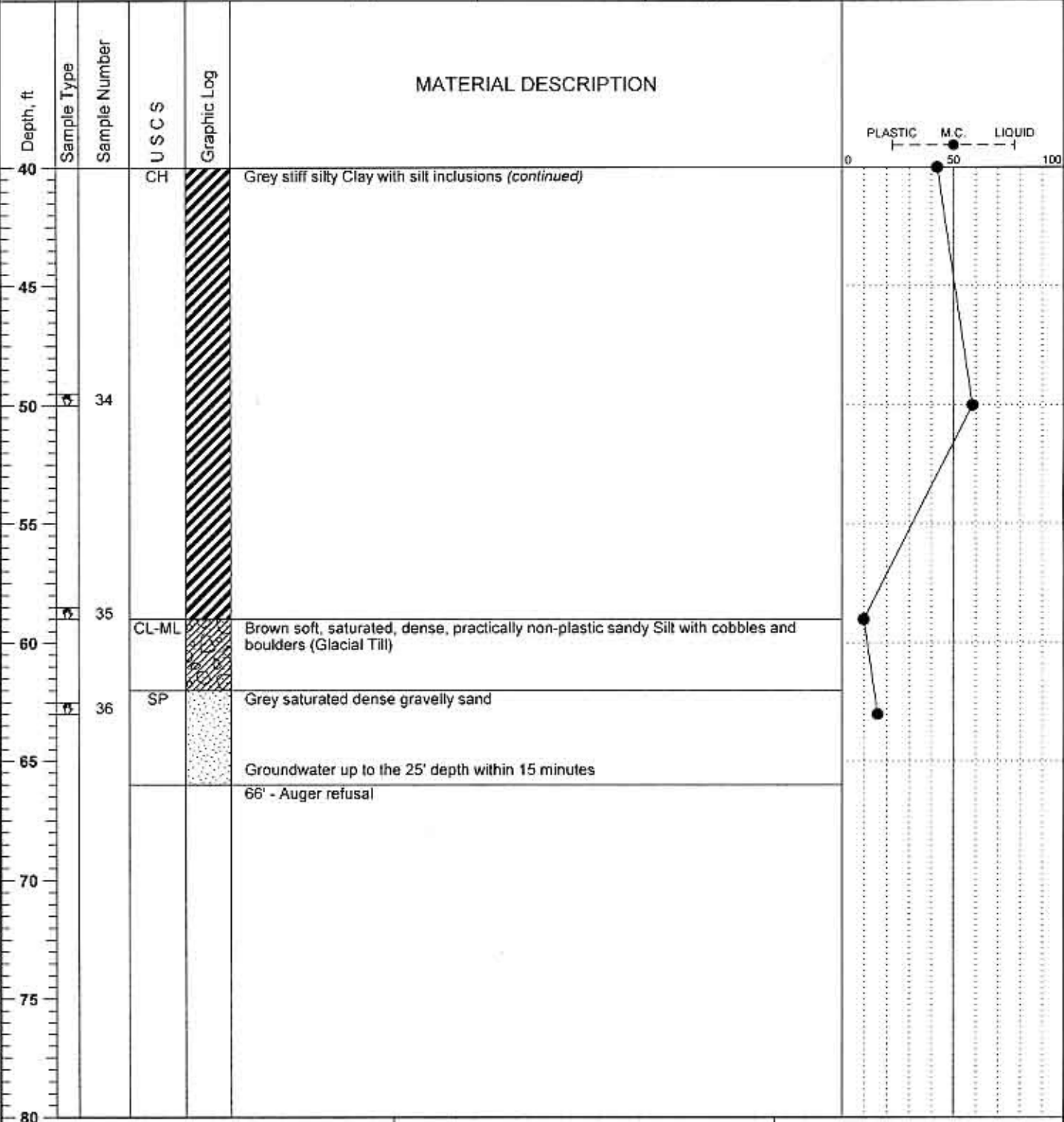

TEST HOLE LOG 405-2004-RRCC-MAIN STREET GPJ M.BLOCK ASSOC. GDOT 12/20/04

SAMPLE TYPE SYMBOLS

- Split Spoon
- Vane Shear
- Grab Sample
- Shelby Tube
- Auger Cuttings
- Rock Core

WATER LEVELS

| | | | |
|-------------|------------------------------|----------------------|---------|
| Drill Rig: | Track Mounted SoilMec | Phreatic Surface #1: | 25.0 ft |
| Auger: | 24" dia. telescopic auger | | |
| Contractor: | Subterranean (Manitoba) Ltd. | | |



M. Block & Associates Ltd.
 2484 Ferrier Street
 Winnipeg, Manitoba, R2V 4P6
 Telephone: (204)-334-5356
 Fax: (204)-339-7976

129 Grand Trunk Street
 Dryden, Ontario P8N 2W4
 Telephone: (807)-223-8384
 Fax: (807)-223-8384

TEST HOLE NO.: 4
 Sheet 1 of 1

Client: Prairie Architects Inc. Job No.: 405-2004 Logged By: T. Gluck, EIT Date: 5/2/04
 Project: Red River Community Centre Redevelopment Reviewed By: J. Block, P. Eng. Time: 9:45 AM
 Location: Main Street & Murray Avenue in Winnipeg Elevation: 99.42m Drawing Number: 5006

| Depth, ft | Sample Type | Sample Number | USCS | Graphic Log | MATERIAL DESCRIPTION | PLASTIC | M.C. | LIQUID |
|-----------|-------------|---------------|------|-------------|---|---------|------|--------|
| 0 | | 37 | FILL | | Black/brown frozen silty clay Fill | | 50 | |
| | | 38 | | | | | | |
| | | 39 | | | | | | |
| | | 40 | CL | | Brown firm silty Clay | | | |
| 5 | | 41 | | | | | | |
| | | 42 | CH | | Brown stiff silty Clay with silt inclusions | | | |
| | | | | | 6' - End of test hole | | | |
| 10 | | | | | | | | |
| 15 | | | | | | | | |
| 20 | | | | | | | | |
| 25 | | | | | | | | |
| 30 | | | | | | | | |
| 35 | | | | | | | | |
| 40 | | | | | | | | |

TEST HOLE LOG 405-2004-RRCC-MAIN STREET.GPJ M. BLOCK.ASSOC.GDT 12/2004

SAMPLE TYPE SYMBOLS

- Split Spoon
- Vane Shear
- Grab Sample
- Shelby Tube
- Auger Cuttings
- Rock Core

WATER LEVELS

Drill Rig: Track Mounted SoilMec
 Auger: 24" dia. telescopic auger
 Contractor: Subterranean (Manitoba) Ltd.
 No Ground Water Encountered



M. Block & Associates Ltd.
 2484 Ferrier Street
 Winnipeg, Manitoba, R2V 4P6
 Telephone: (204)-334-5356
 Fax: (204)-339-7976

129 Grand Trunk Street
 Dryden, Ontario P8N 2W4
 Telephone: (807)-223-8384
 Fax: (807)-223-8384

TEST HOLE NO.: 5
 Sheet 1 of 1

Client: Prairie Architects Inc. Job No.: 405-2004 Logged By: T. Gluck, EIT Date: 5/2/04
 Project: Red River Community Centre Redevelopment Reviewed By: J. Block, P. Eng. Time: 9:50 AM
 Location: Main Street & Murray Avenue in Winnipeg Elevation: 99.53m Drawing Number: 5006

| Depth, ft | Sample Type | Sample Number | USCS | Graphic Log | MATERIAL DESCRIPTION | PLASTIC | M.C. | LIQUID |
|-----------|-------------|---------------|------|-------------|---|---------|------|--------|
| 0 | | 43 | FILL | | Black/brown frozen silty clay Fill | | 50 | |
| | | 44 | | | | | | |
| | | 45 | | | | | | |
| | | 46 | CL | | Brown firm silty Clay | | | |
| 5 | | 47 | | | | | | |
| | | 48 | CH | | Brown stiff silty Clay with silt inclusions | | | |
| | | | | | 6' - End of test hole | | | |
| 10 | | | | | | | | |
| 15 | | | | | | | | |
| 20 | | | | | | | | |
| 25 | | | | | | | | |
| 30 | | | | | | | | |
| 35 | | | | | | | | |
| 40 | | | | | | | | |

TEST HOLE LOG 405-2004-RRCC-MAIN STREET.GPJ M.BLOCK.ASSOC.GDT 12/2/04

SAMPLE TYPE SYMBOLS

- Split Spoon
- Vane Shear
- Grab Sample
- Shelby Tube
- Auger Cuttings
- Rock Core

WATER LEVELS

Drill Rig: Track Mounted SoilMec
 Auger: 24" dia. telescopic auger
 Contractor: Subterranean (Manitoba) Ltd.
 No Ground Water Encountered



M. Block & Associates Ltd.

2484 Ferrier Street
Winnipeg, Manitoba, R2V 4P6
Telephone: (204)-334-5356
Fax: (204)-339-7976

129 Grand Trunk Street
Dryden, Ontario P8N 2W4
Telephone: (807)-223-8384
Fax: (807)-223-8384

TEST HOLE NO.: 6
Sheet 1 of 1

| | | | |
|---|-------------------|--------------------------------|----------------|
| Client: Prairie Architects Inc. | Job No.: 405-2004 | Logged By: T. Gluck, EIT | Date: 5/2/04 |
| Project: Red River Community Centre Redevelopment | | Reviewed By: J. Block, P. Eng. | Time: 10:00 AM |
| Location: Main Street & Murray Avenue in Winnipeg | Elevation: 99.35m | Drawing Number: 5006 | |

| Depth, ft | Sample Type | Sample Number | USCS | Graphic Log | MATERIAL DESCRIPTION | PLASTIC | M.C. | LIQUID |
|-----------|-------------|---------------|------|-------------|---|---------|------|--------|
| 0 | | 49 | FILL | | Black/brown frozen silty clay Fill | | | |
| | | 50 | | | | | | |
| | | 51 | CL | | Brown firm to stiff silty Clay | | | |
| | | 52 | | | | | | |
| 5 | | 53 | | | | | | |
| | | 54 | CH | | Brown stiff silty Clay with silt inclusions | | | |
| | | | | | 6' - End of test hole | | | |
| 10 | | | | | | | | |
| 15 | | | | | | | | |
| 20 | | | | | | | | |
| 25 | | | | | | | | |
| 30 | | | | | | | | |
| 35 | | | | | | | | |
| 40 | | | | | | | | |

TEST HOLE LOG 405-2004-RRCC-MAIN STREET GP J. M. BLOCK ASSOC. GDT 12/2/04

SAMPLE TYPE SYMBOLS

- Split Spoon
- Vane Shear
- Grab Sample
- Shelby Tube
- Auger Cuttings
- Rock Core

WATER LEVELS

| | | |
|-------------|------------------------------|-----------------------------|
| Drill Rig: | Track Mounted SoilMec | No Ground Water Encountered |
| Auger: | 24" dia. telescopic auger | |
| Contractor: | Subterranean (Manitoba) Ltd. | |

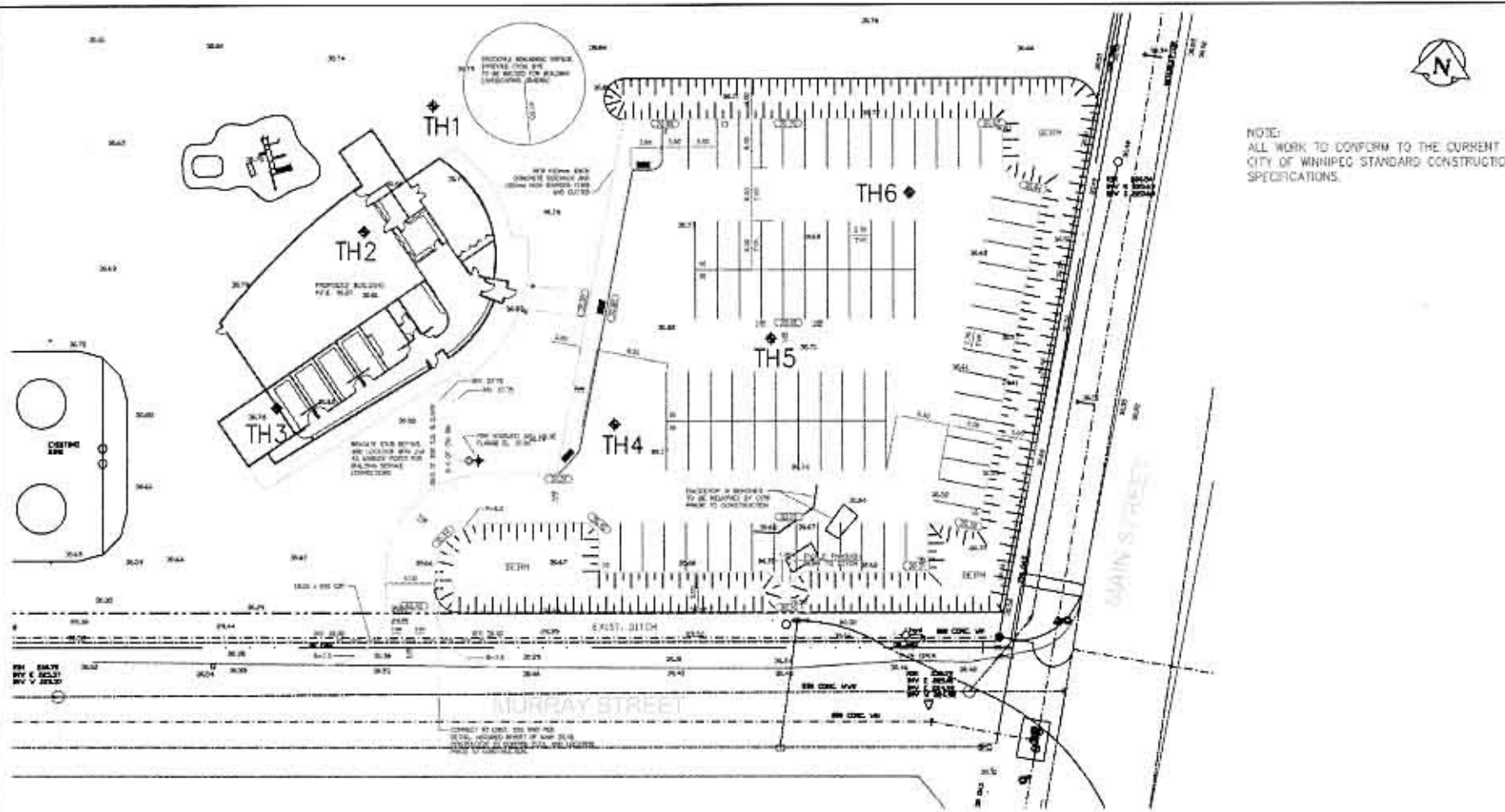

NOTE:
ALL WORK TO CONFORM TO THE CURRENT
CITY OF WINNIPEG STANDARD CONSTRUCTION
SPECIFICATIONS.

| REVISIONS | | |
|-----------|------------|---------------------------|
| NO. | DATE | PARTICULARS |
| 1 | 2014-11-10 | THE DRAWING REVISION PLAN |
| | | |
| | | |
| | | |

NOTES

THIS DOCUMENT IS THE PROPERTY OF
NOLAN ENGINEERS & PLANNERS INC.
IT IS TO BE USED ONLY FOR THE PROJECT
AND SITE SPECIFICALLY IDENTIFIED IN
THIS DOCUMENT. IT IS NOT TO BE
REPRODUCED, COPIED, OR TRANSMITTED
IN ANY FORM OR BY ANY MEANS,
ELECTRONIC OR MECHANICAL, INCLUDING
PHOTOCOPYING, RECORDING, OR BY ANY
INFORMATION STORAGE AND RETRIEVAL
SYSTEM, WITHOUT THE WRITTEN
CONSENT OF NOLAN ENGINEERS &
PLANNERS INC.

NOLAN Engineers & Planners Inc.
Suite 111-10 Lakeside Plaza, Winnipeg, Manitoba R2S 2P8
Phone: (204) 953-1576 Fax: (204) 953-1588

**RED RIVER
COMMUNITY CENTRE
REDEVELOPMENT**

PROJECT
LOCATION: 80
101 MURRAY AVENUE
THE CITY OF WINNIPEG
DRAWN: 1110

Site Plan

| DATE | APPROVED | ISSUED |
|---------------|---------------------|----------|
| TK | NJC | C01 |
| DATE | DATE | |
| 11/10 | 2014-11-26 | |
| NO. OF SHEETS | TOTAL NO. OF SHEETS | REVISION |
| 4/01 | 10/11 | R-0 |

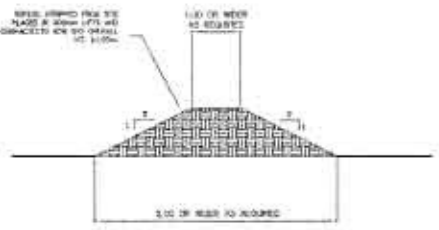

TYPICAL BERM SECTION

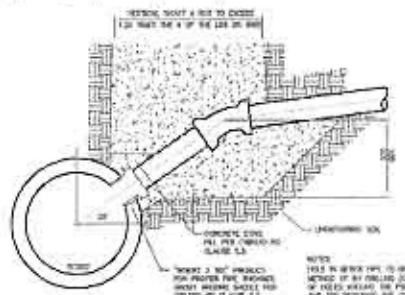

NOTE:
THIS IS A PRELIMINARY PLAN. IT IS TO BE USED FOR CONSTRUCTION PURPOSES ONLY. IT IS NOT TO BE USED FOR PERMITS OR FOR ANY OTHER PURPOSES WITHOUT THE WRITTEN CONSENT OF NOLAN ENGINEERS & PLANNERS INC.

SCALE: N.T.S.

PAVEMENT DETAILS

Car Traffic Areas

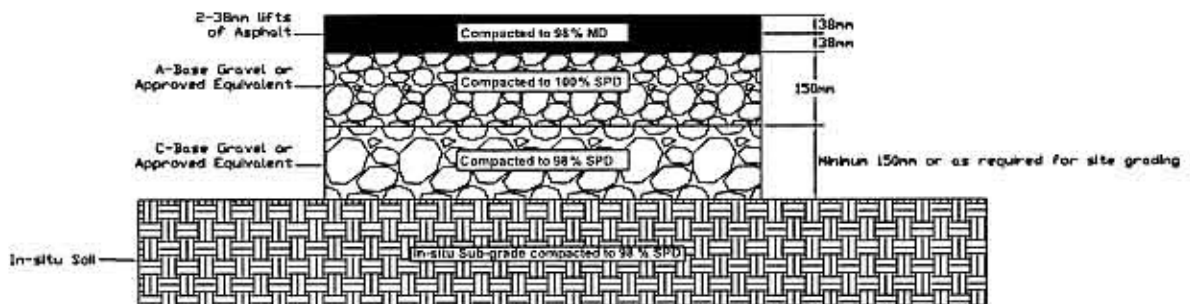

Truck Traffic Areas

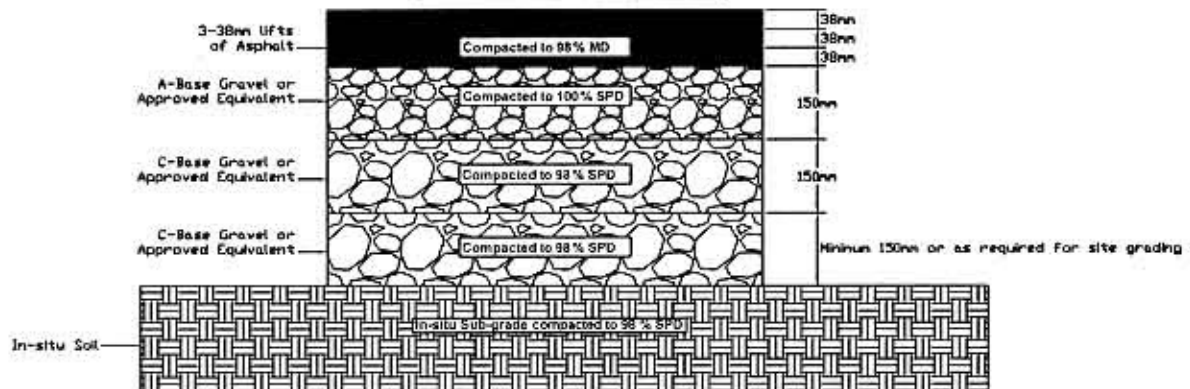

M. Block & Associates Ltd.
2484 Ferrier Street
Winnipeg, Manitoba
R2V 4P6
Phone: (204)-334-5356
Fax: (204)-339-7976

Drawing: PAVEMENTS' STRUCTURES
Drawn By: T. Gluck, EIT
Reviewed By: J. Block, P. Eng.

Project: Red River C. C. Redevelopment
Project Number: 405-2004
Drawing Number: 5006

| Borehole | Depth (ft) | Liquid Limit | Plastic Limit | Plasticity Index | Maximum Size (mm) | %<#200 Sieve | Classification | Water Content (%) | Dry Density (pcf) | Saturation (%) | Void Ratio |
|----------|------------|--------------|---------------|------------------|-------------------|--------------|----------------|-------------------|-------------------|----------------|------------|
| 1 | 1.0 | | | | | | | 34.6 | | | |
| 1 | 2.0 | | | | | | | 28.6 | | | |
| 1 | 3.0 | | | | | | | 25.6 | | | |
| 1 | 4.0 | | | | | | | 28.6 | | | |
| 1 | 11.0 | | | | | | | 57.3 | | | |
| 1 | 21.0 | | | | | | | 51.1 | | | |
| 1 | 31.0 | | | | | | | 46.7 | | | |
| 1 | 41.0 | | | | | | | 42.4 | | | |
| 1 | 51.0 | | | | | | | 52.1 | | | |
| 1 | 59.0 | | | | | | | 13.0 | | | |
| 1 | 62.0 | | | | | | | 13.1 | | | |
| 2 | 1.0 | | | | | | | 22.4 | | | |
| 2 | 2.0 | | | | | | | 27.1 | | | |
| 2 | 3.0 | | | | | | | 27.9 | | | |
| 2 | 4.0 | | | | | | | 26.2 | | | |
| 2 | 5.0 | | | | | | | 32.4 | | | |
| 2 | 10.0 | | | | | | | 27.6 | | | |
| 2 | 20.0 | | | | | | | 52.6 | | | |
| 2 | 30.0 | | | | | | | 46.4 | | | |
| 2 | 40.0 | | | | | | | 30.0 | | | |
| 2 | 50.0 | | | | | | | 59.5 | | | |
| 2 | 60.0 | | | | | | | 17.8 | | | |
| 2 | 64.0 | | | | | | | 9.9 | | | |
| 2 | 66.0 | | | | | | | 10.1 | | | |
| 3 | 1.0 | | | | | | | 21.5 | | | |
| 3 | 2.0 | | | | | | | 25.0 | | | |
| 3 | 3.0 | | | | | | | 28.1 | | | |
| 3 | 4.0 | | | | | | | 28.1 | | | |
| 3 | 5.0 | | | | | | | 29.1 | | | |
| 3 | 10.0 | | | | | | | 22.6 | | | |
| 3 | 20.0 | | | | | | | 54.7 | | | |
| 3 | 30.0 | | | | | | | 47.0 | | | |
| 3 | 40.0 | | | | | | | 42.6 | | | |
| 3 | 50.0 | | | | | | | 58.5 | | | |
| 3 | 59.0 | | | | | | | 9.7 | | | |
| 3 | 63.0 | | | | | | | 15.9 | | | |
| 4 | 1.0 | | | | | | | 23.0 | | | |
| 4 | 2.0 | | | | | | | 21.8 | | | |
| 4 | 3.0 | | | | | | | 24.6 | | | |
| 4 | 4.0 | | | | | | | 26.0 | | | |
| 4 | 5.0 | | | | | | | 27.7 | | | |
| 4 | 6.0 | | | | | | | 28.7 | | | |
| 5 | 1.0 | | | | | | | 31.4 | | | |

CAN EM LAB SUMMARY 405-2004-PRCC-MAIN STREET.GPJ M.BLOCK ASSOC.GDT 12/2/04



M. Block & Associates Ltd.
 2484 Ferrier Street
 Winnipeg, Manitoba, R2V 4P6
 Telephone: (204)-334-5356
 Fax: (204)-339-7976

Summary of Laboratory Results

Client: Prairie Architects Inc.
 Project: Red River Community Centre Redevelopment
 Location: Main Street & Murray Avenue in Winnipeg
 Number: 405-2004

| Borehole | Depth (ft) | Liquid Limit | Plastic Limit | Plasticity Index | Maximum Size (mm) | %<#200 Sieve | Classification | Water Content (%) | Dry Density (pcf) | Saturation (%) | Void Ratio |
|----------|------------|--------------|---------------|------------------|-------------------|--------------|----------------|-------------------|-------------------|----------------|------------|
| 5 | 2.0 | | | | | | | 26.0 | | | |
| 5 | 3.0 | | | | | | | 30.2 | | | |
| 5 | 4.0 | | | | | | | 26.6 | | | |
| 5 | 5.0 | | | | | | | 24.8 | | | |
| 5 | 6.0 | | | | | | | 26.0 | | | |
| 6 | 1.0 | | | | | | | 24.5 | | | |
| 6 | 2.0 | | | | | | | 26.2 | | | |
| 6 | 3.0 | | | | | | | 24.7 | | | |
| 6 | 4.0 | | | | | | | 27.4 | | | |
| 6 | 5.0 | | | | | | | 27.2 | | | |
| 6 | 6.0 | | | | | | | 29.2 | | | |

CAN EM LAB SUMMARY 405-2004-RRCC-MAIN STREET GRJ M BLOCK ASSOC.GDT. 12/2/04



M. Block & Associates Ltd.
 2484 Ferrier Street
 Winnipeg, Manitoba, R2V 4P6
 Telephone: (204)-334-5356
 Fax: (204)-339-7976

Summary of Laboratory Results

Client: Prairie Architects Inc.
 Project: Red River Community Centre Redevelopment
 Location: Main Street & Murray Avenue in Winnipeg
 Number: 405-2004

END OF SECTION

SEPARATE PRICES

1. The Contractor shall submit Separate Prices if required on the Bid Form.
2. The Separate Prices described herein **ARE TO BE INCLUDED IN THE TOTAL BID PRICE.**
3. The City reserves the right to delete items listed under "SEPARATE PRICES" to the Contract.
4. Submit complete and accurate prices for each Separate Price, including overhead and profit, all labour and materials. Include in the Separate Price all costs for Work by all Sub-trades whose Work is affected.
5. Separate Prices submitted are deemed to be complete prices and therefore, claims for extras to the Contract due to the addition of a Separate Price will not be accepted.
6. Acceptance of Separate Prices at any time during the period from time of submittal of the Bid through the period of the Contract is at the sole discretion of The City.
7. Separate Prices will be deleted sequentially beginning with Separate price number 1.
8. The low bid will be determined on the basis of the lowest Bid in accordance with the Contract Documents on which the Project is to be actually constructed, including those separates for which prices have been invited and which are to be incorporated in the Work.

Separate Price #1

Delete landscape stone (see Section 04233 – Random Ashlar Stone) and replace with sod (see Section 02933) as spec'd.

\$ _____

Separate Price #2

Delete random ashlar limestone, mortar, and support angle (see Section 04051, 04060, 04233 and 05500), as indicated on drawings and replace with split face concrete block veneer (see Section 04220).

\$ _____

Separate Price #3

Delete prefinished acoustical wall panels (See Section 10999) as specified in rooms 110 Gym and 104 Multipurpose Room.

\$ _____

Separate Price #4

Delete fiber cement panels (See Section 07450) on furring as indicated on drawings on North and West Elevations (North of Grid D) and East Elevation (North of Grid B on lower level, North of C Grid on Upper level) and replace with Cement stucco (See Section 09225) on wire mesh.

\$ _____

Separate Price #5

Delete Sports flooring in room 109 Gym and replace with VCT flooring (See Section 09651).

\$ _____

Separate Price #6

Delete Thermal Glazing Units (See Section 08950) at high level in Gymnasium. Wood support headers to remain. Frame in and complete interior / exterior finish with similar adjacent materials, wood support header to remain in structure for future window installation.

\$ _____

END OF SECTION

| ROOM NAME | FLOORS: | | WALLS: | | | | | | | | CEILINGS: | | Notes |
|---------------------|---------|------|--------|------|-------|------|-------|------|-------|------|-----------|------|-------|
| | FLR. | BASE | WEST | | NORTH | | EAST | | SOUTH | | MAT'L. | FIN. | |
| | | | MAT'L | FIN. | MAT'L | FIN. | MAT'L | FIN. | MAT'L | FIN. | | | |
| 101 Vestibule | PO | PO | GWB | PT | GWB | PT | GWB | PT | GWB | PT | GWB | PT | 5, 6 |
| 102 Skatechange | MFF | R | GWB | PT | GWB | PT | GWB | PT | GWB | PT | GWB | PT | 6 |
| 103 Office | SV | R | GWB | PT | GWB | PT | GWB | PT | GWB | PT | GWB | PT | |
| 104 Multi-purp. Rm. | SV | R | GWB | PT | GWB | PT | GWB | PT | GWB | PT | GWB | PT | 6 |
| 105 Canteen | SV | SV | GWB | PT | GWB | PT | GWB | PT | GWB | PT | GWB | PT | 4 |
| 106 Kitchen | SV | SV | GWB | PT | GWB | PT | GWB | PT | GWB | PT | GWB | PT | 4 |
| 107 Bar | SV | SV | GWB | PT | GWB | PT | GWB | PT | GWB | PT | GWB | PT | 4 |
| 108 Storage | VCT | R | GWB | PT | GWB | PT | GWB | PT | GWB | PT | GWB | PT | |
| 109 Gym Storage | VCT | R | GWB | PT | GWB | PT | GWB | PT | GWB | PT | GWB | PT | |
| 110 Gym | GF | R | GWB | PT | GWB | PT | GWB | PT | GWB | PT | GWB | PT | 6, 7 |
| 111 Female W/C | MFF | PO | GWB | PT | GWB | PT | GWB | PT | GWB | PT | GWB | PT | 1 |
| 112 Male W/C | MFF | PO | GWB | PT | GWB | PT | GWB | PT | GWB | PT | GWB | PT | 1 |
| 113 Dressing rm. | MFF | R | GWB | PT | GWB | PT | GWB | PT | GWB | PT | GWB | PT | 6 |
| 114 Dressing rm. | MFF | R | GWB | PT | GWB | PT | GWB | PT | GWB | PT | GWB | PT | 6 |
| 115 Dressing rm. | MFF | R | GWB | PT | GWB | PT | GWB | PT | GWB | PT | GWB | PT | 6 |
| 116 Dressing rm. | MFF | R | GWB | PT | GWB | PT | GWB | PT | GWB | PT | GWB | PT | 6 |
| 117 Vestibule | PO | PO | GWB | PT | GWB | PT | GWB | PT | GWB | PT | GWB | PT | 5,6 |
| 118 Corridor | MFF | R | GWB | PT | GWB | PT | GWB | PT | GWB | PT | GWB | PT | 6 |
| 119 Dressing Rm. | MFF | R | GWB | PT | GWB | PT | GWB | PT | GWB | PT | GWB | PT | 6 |
| 120 Dressing Rm. | MFF | R | GWB | PT | GWB | PT | GWB | PT | GWB | PT | GWB | PT | 6 |
| 121 Referee | MFF | R | GWB | PT | GWB | PT | GWB | PT | GWB | PT | GWB | PT | |
| 122 Janitor | SV | SV | GWB | PT | GWB | PT | GWB | PT | GWB | PT | GWB | PT | 4 |
| 123 Viewing | MFF | R | GWB | PT | GWB | PT | GWB | PT | GWB | PT | GWB | PT | 6 |
| 124 Gym Storage | VCT | R | GWB | PT | GWB | PT | GWB | PT | GWB | PT | GWB | PT | |
| 125 Mechanical | CO | R | GWB | PT | GWB | PT | GWB | PT | GWB | PT | GWB | PT | 2 |
| 126 Zamboni | CO | R | GWB | PT | GWB | PT | GWB | PT | GWB | PT | GWB | PT | 2,8. |
| 201 Mechanical | CO | R | GWB | PT | GWB | PT | GWB | PT | GWB | PT | GWB | PT | 2 |
| | | | | | | | | | | | | | |
| | | | | | | | | | | | | | |
| | | | | | | | | | | | | | |
| | | | | | | | | | | | | | |
| | | | | | | | | | | | | | |
| | | | | | | | | | | | | | |
| | | | | | | | | | | | | | |
| | | | | | | | | | | | | | |
| | | | | | | | | | | | | | |
| | | | | | | | | | | | | | |
| | | | | | | | | | | | | | |
| | | | | | | | | | | | | | |
| | | | | | | | | | | | | | |

NOTES:

| | | | |
|-------------------|-------------------|----------------|-----------------------------|
| CT Ceramic Tile | ACT Acoustic Tile | VCT Vinyl Tile | CO Concrete |
| PO Porcelain Tile | GWB Gypsum Board | R Rubber/Vinyl | GF Gym Floor |
| SV Sheet Vinyl | CPT Carpet | PT Paint | MFF Multi-Function Flooring |

NOTES:

| | |
|---|--|
| 1. Porcelain tile on walls; Refer to Interior Elevations for heights. | 3. See details for colors. |
| 2. Sealed floor. | 4. Cove flooring. |
| 5. Tile base to 1/2 tile height. | 6. Wall panelling, see int. elevs. |
| 7. See Alternate Prices | 8. Inner wall GWB to be 16mm DensArmor Plus w/ fibreglass tape |

| Door # | Size | | | | | Door | | | | Frame | | | | Hardware | | Notes |
|--------|------|------|------|--------|------|-------|-----|------|------|-------|------|--------|--------|----------|--------|-------|
| | 914 | 1067 | 1220 | Single | Pair | Mat'l | ULC | Type | Fin. | Mat'l | Type | Finish | Detail | Code | Acous. | |
| D101A | | X | | X | | AL | 20 | C | PF | AL | B | PF | - | 1 | | 2,3 |
| D101B | | X | | X | | AL | | C | PF | AL | B | PF | - | 2 | | 2,3 |
| D103 | X | | | X | | HM | | A | PT | HM(W) | A | PT | - | 3 | | |
| D104 | X | | | X | | HM | | A | PT | HM(W) | C | PT | - | 4 | | |
| D104B | X | | | X | | IM | 20 | A | PT | HM(W) | A | PT | - | 24 | | |
| D105 | X | | | X | | HM | | A | PT | HM(W) | A | PT | - | 5 | | |
| D106A | X | | | X | | HM | | A | PT | HM(W) | A | PT | - | 6 | | |
| D106B | X | | | X | | HM | | A | PT | HM(W) | A | PT | - | 17 | | |
| D107 | X | | | X | | HM | | A | PT | HM(W) | A | PT | - | 7 | | |
| D108 | X | | | | X | HM | | A | PT | HM(W) | A | PT | - | 8 | | |
| D109A | | X | | X | | HM | | A | PT | HM(W) | A | PT | - | 9 | | |
| D109B | X | | | X | | HM | | A | PT | HM(W) | A | PT | - | 25 | | |
| D110A | | X | | X | | HM | | A | PT | HM(W) | D | PT | - | 10 | | |
| D110B | X | | | X | | IM | 20 | A | PT | HM(W) | A | PT | - | 11 | | 4 |
| D110C | X | | | | X | IM | 20 | A | PT | HM(W) | F | PT | - | 18 | | 4,6 |
| D111 | X | | | X | | HM | | A | PT | HM(W) | A | PT | - | 12 | | |
| D112 | X | | | X | | HM | | A | PT | HM(W) | A | PT | - | 12 | | |
| D113 | | X | | X | | HM | | A | PT | HM(W) | A | PT | - | 13 | | |
| D114A | | X | | X | | HM | | A | PT | HM(W) | A | PT | - | 13 | | |
| D114B | X | | | X | | HM | | A | PT | HM(W) | A | PT | - | 19 | | |
| D115 | | X | | X | | HM | | A | PT | HM(W) | A | PT | - | 13 | | |
| D116A | | X | | X | | HM | | A | PT | HM(W) | A | PT | - | 13 | | |
| D116B | X | | | X | | HM | | A | PT | HM(W) | A | PT | - | 19 | | |
| D117A | X | | | X | | HM | 20 | A | PT | HM(W) | B | PT | - | 14 | | |
| D117B | X | | | X | | IM | 20 | A | PT | HM(W) | A | PT | - | 15 | | |
| D119 | | X | | X | | HM | | A | PT | HM(W) | A | PT | - | 13 | | 2 |
| D120 | | X | | X | | HM | | A | PT | HM(W) | A | PT | - | 13 | | |
| D121 | X | | | X | | HM | | A | PT | HM(W) | A | PT | - | 20 | | |
| D122 | X | | | X | | HM | 20 | A | PT | HM | A | PT | - | 21 | | |
| D124 | X | | | | X | HM | 20 | A | PT | HM | F | PT | - | 26 | - | - |
| D125 | X | | | X | | HM | 60 | A | PT | HM | A | PT | - | 22 | | |
| D126 | X | | | X | | HM | 60 | A | PT | HM | A | PT | - | 23 | | |
| D201A | | X | | X | | HM | 45 | A | PT | HM(W) | A | PT | - | 16 | | |
| D201B | | | | X | | HM | 45 | | PT | HM(W) | | PT | - | 27 | | 5 |

- | | | | |
|-------|---------------------------|--------|---|
| PT | PAINT | NOTES: | |
| S | STAIN | 1 | ALL DOORS STANDARD 2150mm HEIGHT UNLESS NOTED OTHERWISE |
| PF | PREFINISHED | 2 | ALUMINUM DOORS IN STANDARD IMPERIAL HEIGHT (2150mm) |
| AL | ALUMINUM | 3 | AUTO OPENER |
| HM | HOLLOW METAL | 4 | THERMALLY BROKEN METAL FRAME |
| IM | INSULATED METAL | 5 | REFER TO A2-1 FOR FURTHER DOOR AND FRAME INFORMATION. |
| SC | SOLID CORE | 6 | |
| HM(W) | HOLLOW METAL WELDED FRAME | | |
| WD | WOOD | 7 | PROVIDE CONSTRUCTION CORES FOR EXTERIOR LOCKS. |
| | | 8 | EXTERIOR LOCKSETS TO BE "BEST" LOCKS. |

GROUP #1

| | | | | | |
|--|--------------------|--------------------------------|----|-------|----|
| 1 | CONTINUOUS HINGE | MCK-12HD 83" | 1A | CLEAR | MC |
| 1 | RIM CYLINDER | STANDARD 1E 7 2 RP | 2A | 626 | BS |
| 1 | EXIT DEVICE | 56 55 8504 G ETP LESS ETP TRIM | 2C | 32D | SA |
| 1 | MAGNALOCK | M82SC | 2P | | SU |
| 1 | FRAME SHIM BRACKET | ASB-82 | 2M | CL | SU |
| 1 | PULL | 3012-2 1" X 12" NO.2 | 4A | 32D | SM |
| 1 | DOOR OPERATOR | 4051 2 3/4" - 6 7/8" REVEAL | 5A | EN | SA |
| 1 | OVERHEAD STOP | 698-S | 7A | 26D | SA |
| 2 | WALL SWITCH | 4296H | 9A | | SA |
| 1 | POWER TRANSFER | EPT 10 | 9B | 689 | VO |
| 1 | POWER SOURCE | BPS-24-2 | 9C | | SU |
| 1 | MORTISE CYLINDER | STANDARD 1E 7 4 C4 RP3 | 2B | 626 | BS |
| 1 | KEY SWITCH | MKAN2 | 9D | | SU |
| 1 | LOCK GUARD | LG1 * | 9F | US2G | IE |
| 1 | RELAY BOARD | RB-4-24 | 9J | | SU |
| 1 | THRESHOLD 5" - UL | DS500A X 42" | 8A | | AK |
| BALANCE OF WEATHERSTRIPPING BY DOOR SUPPLIER | | | | | |

GROUP #2

| | | | | | |
|---|------------------|--------------------------------|----|-------|----|
| 1 | CONTINUOUS HINGE | MCK-12HD 83" | 1A | CLEAR | MC |
| 1 | PUSH BAR | 6039.5-2 NO. 2 MTG X NO. 5 MTG | 3A | 32D | SM |
| 1 | PULL BAR | 3012-2 1" x 12" no. 2 | 4A | 32D | SM |
| 1 | DOOR OPERATOR | 4051 2 3/4" - 6 7/8" REVEAL | 5A | EN | SA |
| 1 | HD FLOOR STOP | S114 1.5" | 7B | 26D | SM |
| 2 | WALL SWITCH | 4296H | 9A | | SA |

GROUP #3

| | | | | | |
|---|--------------------|-------------------|----|-----|----|
| 3 | FULL MORTISE HINGE | TA314 4 1/2" X 4" | 1C | 32D | MC |
| 1 | LOCKSET | 28 10G05 LP | 2D | 26D | SA |
| 1 | KICKPLATE 0.050" | K10A 10"X34" | 6A | 32D | SM |
| 1 | HD DOME FLOOR STOP | S101 0.25" | 7C | 26D | SM |

GROUP #4

| | | | | | |
|---|----------------------|-----------------------|----|-----|----|
| 3 | FULL MORTISE HINGE | TA386 4 1/2" X 4 1/2" | 1B | 32D | MC |
| 1 | LOCKSET | 28 10G37 LP | 2Q | 26D | SA |
| 1 | CLOSER | 351 P10 | SD | EN | SA |
| 1 | KICKPLATE 0.050" | K10A 10"X34" | 6A | 32D | SM |
| 1 | OVERHEAD DOOR HOLDEF | 698-H | 7G | 26D | SA |

GROUP #5

| | | | | | |
|---|--------------------|------------------|----|-----|----|
| 3 | FULL MORTISE HINGE | A314 4 1/2" X 4" | 1C | 32D | MC |
| 1 | DEADLOCK | 485 | 2E | 26D | SA |
| 1 | LOCKSET | 28 10G05 LP | 2D | 26D | SA |
| 1 | KICKPLATE 0.050" | K10A 10" X 34" | 6A | 32D | SM |
| 1 | HD DOME FLOOR STOP | S101 0.25" | 7C | 26D | SM |

GROUP #6

| | | | | | |
|------------------------|--------------------|-------------------|----|-----|----|
| 3 | FULL MORTISE HINGE | TA314 4 1/2" X 4" | 1C | 32D | MC |
| 1 | LOCKSET | 8205 LNP | 2R | 26D | SA |
| LOCK LESS OUTSIDE TRIM | | | | | |
| 1 | DROP RING PULL | H401 | 4C | 26D | SM |
| 1 | CLOSER | 1431 RUO DA | | | |
| 1 | KICKPLATE .050" | K10A 10" X 34" | 6A | 32D | SM |
| 1 | HD DOME FLOOR STOP | S101 .25" | 7C | 26D | SM |

GROUP #7

| | | | | | |
|---|--------------------|-----------------------|----|-----|----|
| 3 | FULL MORTISE HINGE | TA314 4 1/2" X 4" NRP | 1D | 32D | MC |
| 1 | DEADLOCK | 485 | 2E | 26D | SA |
| 1 | LOCKSET | 28 10G37 LP | 2Q | 26D | SA |
| 1 | KICKPLATE .050" | K10A 10" X 34" | 6A | 32D | SM |
| 1 | HD DOME FLOOR STOP | S101 .25" | 7C | 26D | SM |

GROUP #8

| | | | | | |
|---|--------------------|-------------------|----|-----|----|
| 6 | FULL MORTISE HINGE | TA314 4 1/2" X 4" | 1C | 32D | MC |
| 1 | LOCKSET | 28 10G04 LP | 2G | 26D | SA |
| 2 | KICKPLATE .050" | K10A 10" X 34" | 6A | 32D | SM |
| 2 | OVERHEAD DOOR STOP | 1538-S | 7D | 26D | SA |
| 2 | HD SURFACE BOLT | F67 8" | 9E | 26D | SM |

GROUP #9

| | | | | | |
|---|------------------------|-----------------------|----|-----|----|
| 4 | FULL MORTISE HINGE | TA314 4 1/2" X 4" NRP | 1C | 32D | MC |
| 1 | DROP RING PULL | H401 | 4C | 26D | SM |
| 1 | LOCKSET | 8204 LNP | 2H | 26D | SA |
| | LOCL LESS OUTSIDE TRIM | C/W CYLINDER | | | |
| 1 | KICKPLATE .050" | K10A 10" X 40" | 6C | 32D | SM |
| 1 | HD FLOOR STOP | S114 1.5" | 7B | 26D | SM |

GROUP #10

| | | | | | |
|---|--------------------|-----------------------|----|-----|----|
| 4 | FULL MORTISE HINGE | TA386 4 1/2" X 4 1/2" | 1B | 32D | MC |
| 1 | EXIT DEVICE | 12 8813 F ETP | 2J | 32D | SA |
| 1 | CLOSER | 351 P10 | 5D | EN | SA |
| 1 | KICKPLATE .050" | K10A 10" X 40" | 6C | 32D | SM |
| 1 | OVERHEAD DOOR STOP | 699-S | 7F | 26D | SA |
| 1 | WEATHERSTRIP | W-21 20' | 8J | BLK | KN |
| 1 | AUTO. DOOR BOTTOM | CT-52 NEOPRENE 42" | 8K | CA | KN |

GROUP #11

| | | | | | |
|---|--------------------|------------------------|----|------|----|
| 3 | FULL MORTISE HINGE | TA314 4 1/2" X 4" NRP | 1D | 32D | MC |
| 1 | MORTISE CYLINDER | STANDARD 1E 7 4 C4 RP3 | 2B | 626 | BS |
| 1 | EXIT DEVICE | 8888 F | 2K | 32D | SA |
| 1 | PULL | 3012-2 1" X 12" NO. 2 | 4A | 32D | SM |
| 1 | CLOSER | 1430 CPS | 5E | EN | SA |
| 1 | KICKPLATE .050" | K10A 10" X 34" | 6A | 32D | SM |
| 1 | WEATHERSTRIP | W-20P 36" | 8B | CA | KN |
| 2 | WEATHERSTRIP | W-50 X 84" | 8C | CA | KN |
| 1 | DOOR SWEEP | W-24S 36" | 8D | CA | KN |
| 1 | THRESHOLD 5" - UL | DS95A 36" | 8E | - | AK |
| 1 | LOCKGUARD | LG1 * | 9F | US2G | IE |

GROUP #12

| | | | | | |
|---|--------------------|-----------------------|----|-----|----|
| 6 | FULL MORTISE HINGE | TA386 4 1/2" X 4 1/2" | 1B | 32D | MC |
| 2 | PUSHPLATE .050" | K11A CUSTOM 20" X 20" | 3B | 32D | SM |
| 2 | PULL / BACKPLATE | 2412-2 1" X 12" NO. 2 | 4B | 32D | SM |
| 2 | CLOSER | 351 UO DA | 5B | EN | SA |
| 2 | KICKPLATE .050" | K10A 16" X 34" | 6B | 32D | SM |
| 2 | CONVEX WALL STOP | S120 | 7E | 26D | SM |

GROUP #13

| | | | | | |
|----|--------------------|-----------------------|----|-----|----|
| 16 | FULL MORTISE HINGE | TA386 4 1/2" X 4 1/2" | 1B | 32D | MC |
| 4 | DEADLOCK | 485 | 2E | 26D | SA |
| 4 | PUSHPLATE .050" | K11A CUSTOM 20" X 20" | 3B | 32D | SM |
| 4 | PULL / BACKPLATE | 2412-2 1" X 12" NO. 2 | 4B | 32D | SM |
| 4 | CLOSER | 351 UO DA | 5B | EN | SA |
| 4 | KICKPLATE .050" | K10A 10" X 40" | 6C | 32D | SM |
| 4 | HD FLOOR STOP | S114 1.5" | 7B | 26D | SM |

GROUP #14

| | | | | | |
|---|------------------|-----------------------|----|-------|----|
| 1 | CONTINUOUS HINGE | MCK-12HD 83" | 1A | CLEAR | MC |
| 1 | PUSHPLATE .050" | K11A CUSTOM 20" X 20" | 3B | 32D | SM |
| 1 | PULL | 3012-2 1" X 12" NO. 2 | 4A | 32D | SM |
| 1 | CLOSER | 351 UO DA | 5B | EN | SA |
| 1 | KICKPLATE .050" | K10A 10" X 40" | 6C | 32D | SM |
| 1 | HD FLOOR STOP | S114 1.5" | 7B | 26D | SM |

GROUP #15

| | | | | | |
|---|---------------------|-----------------------|----|-------|----|
| 1 | CONTINUOUS HINGE | MCK-12HD 83" | 1A | CLEAR | MC |
| 1 | RIM CYLINDER | STANDARD 1E 7 2 RP | 2A | 626 | BS |
| 1 | EXIT DEVICE | 8888 G | 2S | 32D | SA |
| 1 | PULL | 3012-2 1" X 12" NO. 2 | 4A | 32D | SM |
| 1 | CLOSER | 351 P10 | 5D | EN | SA |
| 1 | KICKPLATE .050" | K10A 10" X 40" | 6C | 32D | SM |
| 1 | OVERHEAD DOOR STOP | 699-S | 7F | 26D | SA |
| 1 | WEATHERSTRIP | W-20P X 42" | 8L | CA | KN |
| 2 | WEATHERSTRIPS | W-50 X 84" | 8C | CA | KN |
| 1 | DOOR SWEEP | W-24S X 42" | 8N | CA | KN |
| 1 | THRESHOLD 5" - U.L. | DS95A 48" | 8M | - | AK |

GROUP #16

| | | | | | |
|---|--------------------|-------------------|----|-----|----|
| 4 | FULL MORTISE HINGE | TA314 4 1/2" X 4" | 1C | 32D | MC |
| 1 | LOCKSET | 28 8G04 OB | 2N | 26D | SA |
| 1 | CLOSER | 1430 RUO | 5H | EN | SA |
| 1 | KICKPLATE .050" | K10A 10" X 40" | 6C | 32D | SM |
| 1 | HD DOME FLOOR STOP | S101 .25" | 7C | 26D | SM |

GROUP #17

| | | | | | |
|---|--------------------|-----------------------|----|-----|----|
| 3 | FULL MORTISE HINGE | TA314 4 1/2" X 4" NRP | 1D | 32D | MC |
| 1 | DEADLOCK | 485 | 2E | 26D | SA |
| 1 | PUSHPLATE .050" | K11A CUSTOM 20" X 20" | 3B | 32D | SM |
| 1 | PULL / BACKPLATE | 2412-2 1" X 12" NO. 2 | 4B | 32D | SM |
| 1 | CLOSER | 1431 RUO DA | 5C | EN | SA |
| 1 | KICKPLATE .050" | K10A 10" X 34" | 6A | 32D | SM |
| 1 | OVERHEAD DOOR STOP | 1538-S | 7D | 26D | SA |

GROUP #18

| | | | | | |
|---|---------------------|-----------------------|----|-----|----|
| 6 | FULL MORTISE HINGE | TA314 4 1/2" X 4" NRP | 1D | 32D | MC |
| 2 | EXIT DEVICE | 8888 F | 2K | 32D | SA |
| 2 | CLOSER | 1430 CPS | SE | EN | SA |
| 2 | KICKPLATE .050" | K10A 10" X 34" | 6A | 32D | SM |
| 2 | WEATHERSTRIP | W-20P 36" | 8B | CA | KN |
| 4 | WEATHERSTRIP | W-50 X 84" | 8C | CA | KN |
| 2 | DOOR SWEEP | W-24S 36" | 8D | CA | KN |
| 1 | THRESHOLD 5" - U.L. | DS95A 72" | 8G | - | AK |
| 1 | SET ASTRAGAL | W-40P X 84" | 8H | CA | KN |
| 1 | REMOVABLE MULLION | 980 96" | 9G | CP | SA |

GROUP #19

| | | | | | |
|---|------------------------|-----------------------|----|-----|----|
| 4 | FULL MORTISE HINGE | TA386 4 1/2" X 4 1/2" | 1B | 32D | MC |
| 1 | LOCKSET | 8225 LNP | 2T | 26D | SA |
| | LOCK LESS OUTSIDE TRIM | C/W CYLINDER | | | |
| 1 | CLOSER | 351 UO DA | 5B | EN | SA |
| 1 | KICKPLATE .050" | K10A 10" X 40" | 6C | 32D | SM |
| 1 | HD FLOOR STOP | S114 1.5" | 7B | 26D | SM |
| 1 | WEATHERSTRIP | W-21 20' | 8J | BLK | KN |

GROUP #20

| | | | | | |
|---|--------------------|-----------------------|----|-----|----|
| 3 | FULL MORTISE HINGE | TA314 4 1/2" X 4" | 1C | 32D | MC |
| 1 | DEADLOCK | 485 | 2E | 26D | SA |
| 1 | PUSHPLATE .050" | K11A CUSTOM 20" X 20" | 3B | 32D | SM |
| 1 | PULL / BACKPLATE | 2412-2 1" X 12" NO. 2 | 4B | 32D | SM |
| 1 | CLOSER | 1431 RUO DA | 5C | EN | SA |
| 1 | KICKPLATE .050" | K10A 10" X 32" | 6A | 32D | SM |
| 1 | HD FLOOR STOP | S114 1.5" | 7B | 26D | SM |

GROUP #21

| | | | | | |
|---|--------------------|-------------------|----|------|----|
| 3 | FULL MORTISE HINGE | TA314 4 1/2" X 4" | 1C | 32D | MC |
| 1 | LOCKSET | 28 8G04 OB | 2N | 26D | SA |
| 1 | CLOSER | 1131 RU | 5g | EN | SA |
| 1 | DOME FLOOR STOP | S100 .25" | 7A | 26DD | SM |
| 1 | KICKPLATE .050" | K10A 10" X 34" | 6A | 32D | SM |
| 1 | HD DOME FLOOR STOP | S101 .25" | 7C | 26D | SM |

GROUP #22

| | | | | | |
|---|--------------------|-----------------------|----|-----|----|
| 3 | FULL MORTISE HINGE | TA314 4 1/2" X 4" NRP | 1D | 32D | MC |
| 1 | LOCKSET | 28 8G04 OB | 2N | 26D | SA |
| 1 | CLOSER | 1131 RU | 5G | EN | SA |
| 1 | KICKPLATE .050" | K10A 10" X 34" | 6A | 32D | SM |
| 1 | CONVEX WALL STOP | S120 | 7E | 26D | SM |

GROUP #23

| | | | | | |
|---|--------------------|-------------------|----|-----|----|
| 3 | FULL MORTISE HINGE | TA314 4 1/2" X 4" | 1C | 32D | MC |
| 1 | LOCKSET | 28 8G04 OB | 2N | 26D | SA |
| 1 | CLOSER | 1131 RU | 5G | EN | SA |
| 1 | KICKPLATE .050" | K10A 10" X 34" | 6A | 32D | SM |
| 1 | HD FLOOR STOP | S114 1.5" | 7B | 26D | SM |

GROUP #24

| | | | | | |
|---|--------------------|-----------------------|----|-----|----|
| 3 | FULL MORTISE HINGE | TA314 4 1/2" X 4" NRP | 1D | 32D | MC |
| 1 | EXIT DEVICE | 8888 F | 2K | 32D | SA |
| 1 | CLOSER | 1430 CPS | SE | EN | SA |
| 1 | KICKPLATE .050" | K10A 10" X 34" | 6A | 32D | SM |
| 1 | WEATHERSTRIP | W-20P 36" | 8B | CA | KN |
| 2 | WEATHERSTRIP | W-50 X 84" | 8C | CA | KN |
| 1 | DOOR SWEEP | W-24S 36" | 8D | CA | KN |
| 1 | THRESHOLD 5" - UL | DS95A 36" | 8E | - | AK |

GROUP #25

| | | | | | |
|---|--------------------|-------------------|----|-----|----|
| 3 | FULL MORTISE HINGE | TA314 4 1/2" X 4" | 1C | 32D | MC |
| 1 | LOCKSET | 28 10G04 LP | 2G | 26D | SA |
| 1 | CLOSER | 1131 RU | 5G | EN | SA |
| 1 | KICKPLATE .050" | K10A 10" X 34" | 6A | 32D | SM |
| 1 | HD DOME FLOOR STOP | S101 .25" | 7C | 26D | SM |

GROUP #26

| | | | | | |
|---|--------------------------------|-------------------|----|-----|----|
| 6 | FULL MORTISE HINGE | TA314 4 1/2" X 4" | 1C | 32D | MC |
| 1 | LOCKSET | 8204 LNP | 2H | 26D | SA |
| | LESS OUTSIDE TRIM C/W CYLINDER | | | | |
| 1 | DROP RING PULL | H401 | 4C | 26D | SM |
| 1 | KICKPLATE .050" | K10A 10" X 34" | 6A | 32D | SM |
| 1 | HD FLOOR STOP | S114 1.5" | 7B | 26D | SM |
| 1 | OVERHEAD DOOR STOP | 1538-S | 7D | 26D | SA |
| 2 | HD SURFACE BOLT | F67 8" | 9E | 26D | SM |
| 1 | ASTRAGAL | W-8 84" | 8P | CA | KN |

GROUP #27

| | | | | | |
|---|--------------------|-------------------|----|-----|----|
| 3 | FULL MORTISE HINGE | TA314 4 1/2" X 4" | 1C | 32D | MC |
| 1 | LOCKSET | 28 8G04 OB | 2N | 26D | SA |
| 1 | CLOSER | 1131 RU | 5G | EN | SA |
| 1 | KICKPLATE .050" | K10A 10" X 34" | 6A | 32D | SM |
| 1 | HD DOME FLOOR STOP | S101 .25" | 7C | 26D | SM |

DOOR TYPES

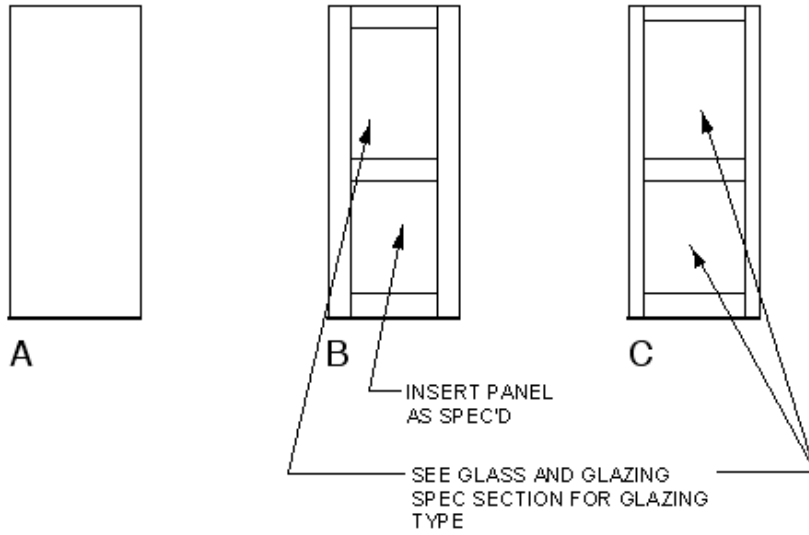

DOOR FRAME TYPES

NOTE: REFER TO FLR. PLANS FOR
REVERSED SCREENS
(POSITION OF DOOR/SIDELITE)

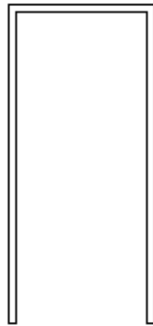

A

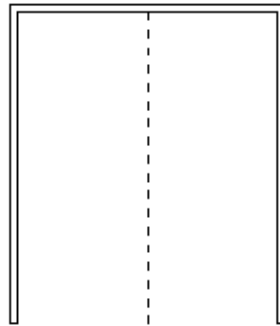

B

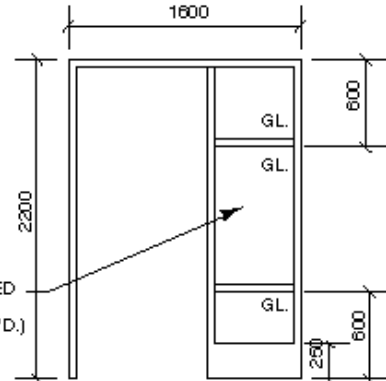

C

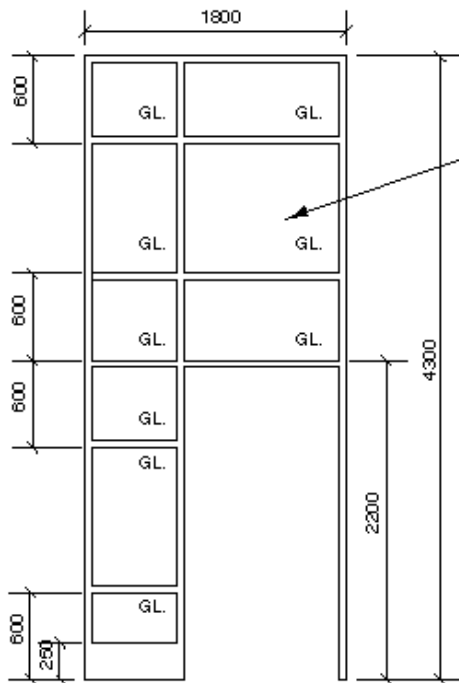

D

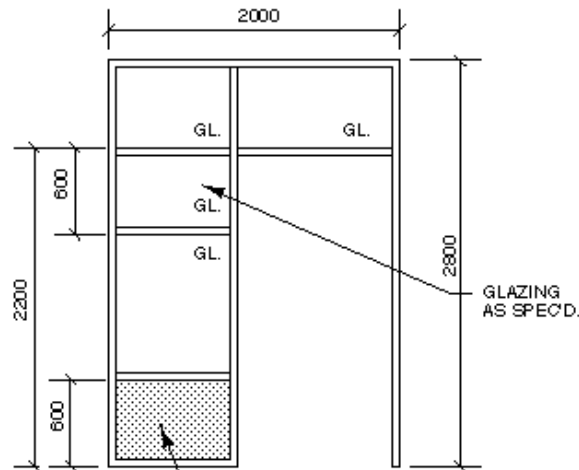

E

PREFIN ALUM SHEET
ADHERED TO 19 G2S
PLYWOOD ON EACH SIDE.

NOTE: SITE CONFIRM ALUM. ENTRY FRAME WIDTH
BEFORE FABRICATION.

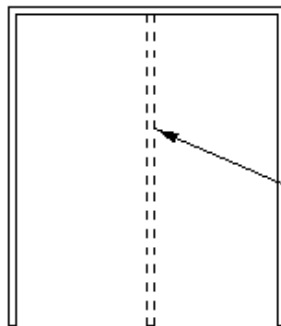

REMOVEABLE

F

FRAME DETAILS

1. EXTERIOR METAL FRAME

NOTE: REFER TO FLOOR PLANS AND WALL SECTIONS FOR WALL CONSTR.

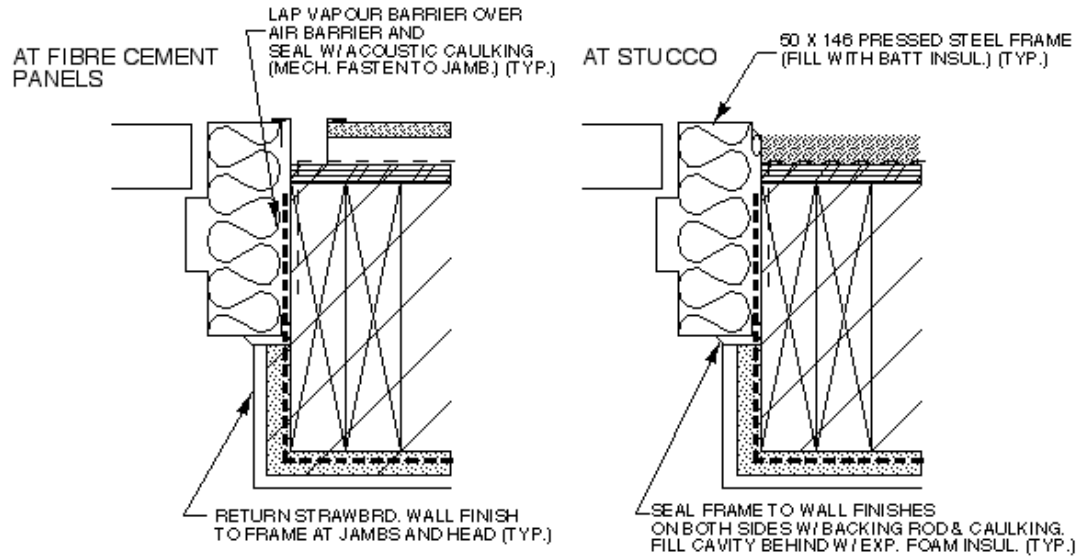

2. EXTERIOR ALUM. FRAME

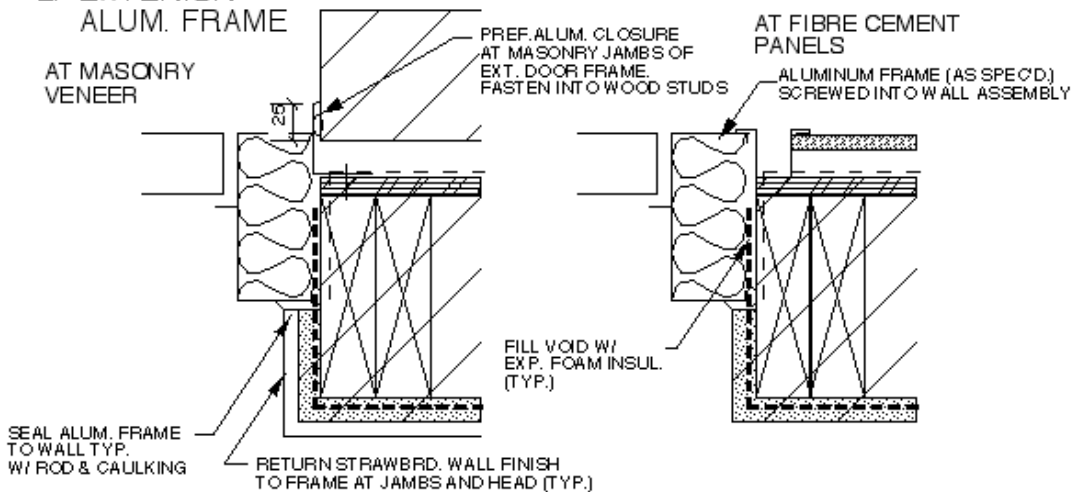

3. INTERIOR METAL FRAME

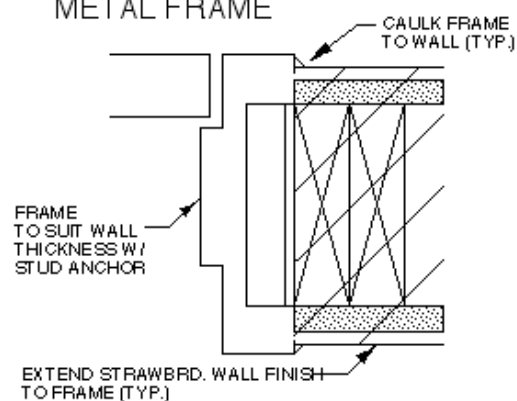

4. INTERIOR ALUM. FRAME

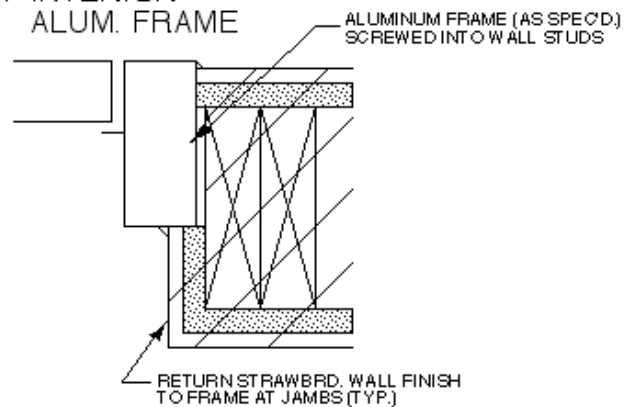

INTERIOR WINDOW TYPES

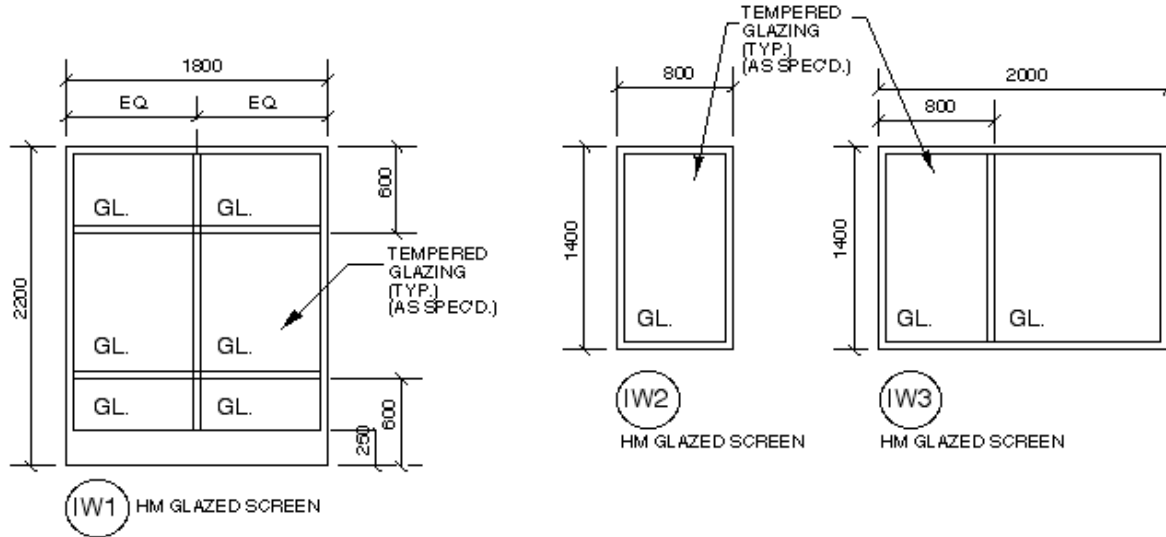

EXTERIOR WINDOW TYPES

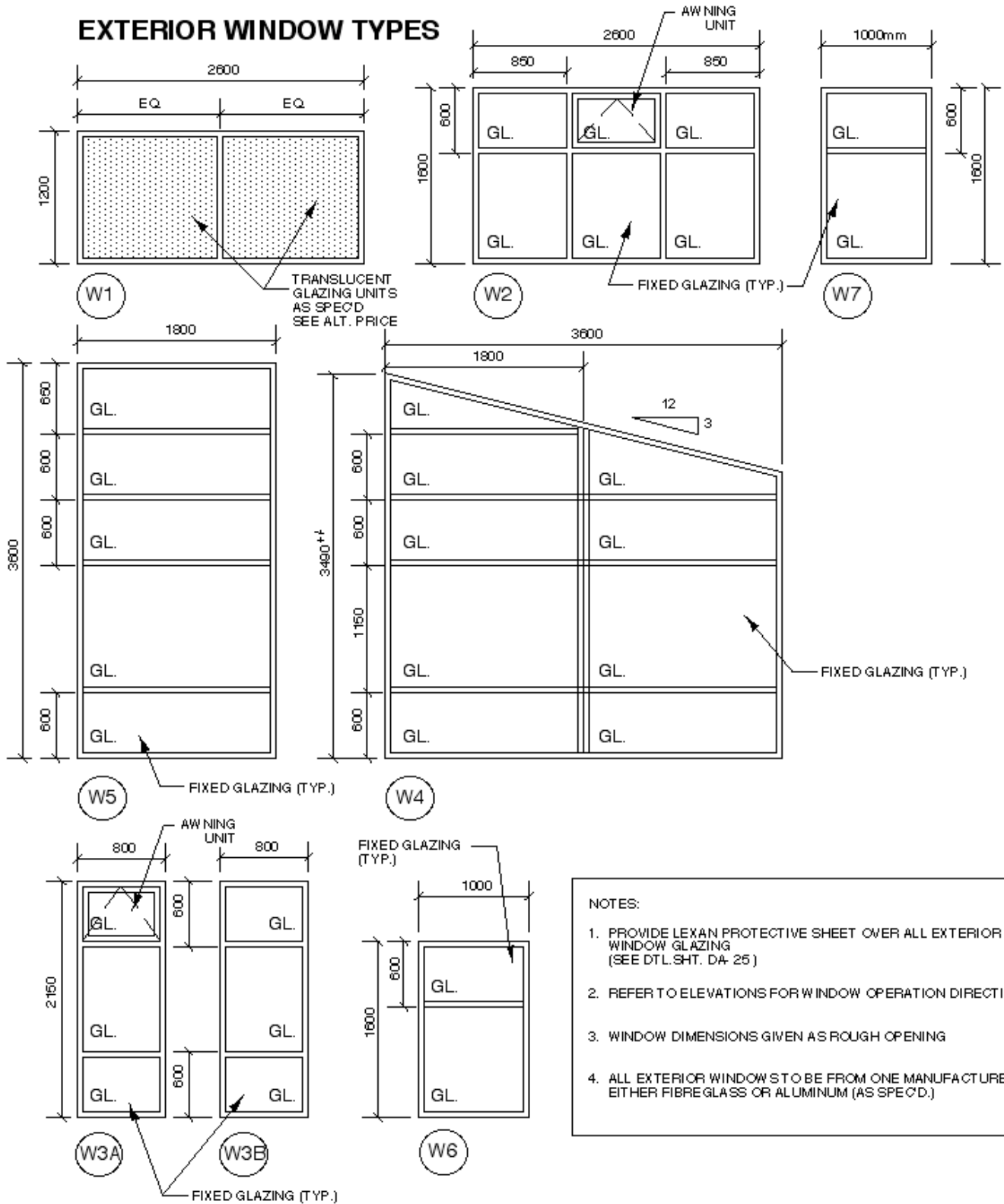

- NOTES:**
1. PROVIDE LEXAN PROTECTIVE SHEET OVER ALL EXTERIOR WINDOW GLAZING (SEE DTL. SHT. DA-25)
 2. REFER TO ELEVATIONS FOR WINDOW OPERATION DIRECTION
 3. WINDOW DIMENSIONS GIVEN AS ROUGH OPENING
 4. ALL EXTERIOR WINDOW S TO BE FROM ONE MANUFACTURER EITHER FIBRE GLASS OR ALUMINUM (AS SPEC'D.)

PART 1 GENERAL

1.1 Environmental Assessment and Mitigation

- .1 The Contractor shall follow these mitigation measures for the duration the construction period in order to minimize the environmental impact of the community centre construction.

1.2 Decreased Air Quality from Fossil Fuel Emissions During Construction

- .1 The following mitigation measures are proposed to reduce emissions from vehicle and equipment use:
 - .1 A high standard of inspection, maintenance, and operational practices shall be implemented for all vehicles and equipment to meet manufacturer's specifications for fuel consumption.
 - .2 No ozone depleting substances shall be used or generated from equipment during construction.
 - .3 Alternative fuels such as gasohol shall be used when possible.
 - .4 Speed limits shall be adhered to in order to optimize fuel economy.
 - .5 Use of low sulphur-containing fuels where available.

1.3 Loss of Soil from Construction Site

- .1 The following mitigation measures are required to prevent or minimize soil loss from the construction area:
 - .1 Clear only the minimum of vegetation required.
 - .2 Preserve vegetation cover for as long as possible.
 - .3 Use engineering erosion control measures such as silt fences, berms, silt blankets as necessary.

1.4 Decreased Vegetation and Habitat from Construction Activities

- .1 The following mitigation measures are required to minimize vegetation loss:
 - .1 Best practices shall be implemented so that only the minimum necessary number of trees is cleared. Landscaping around the building after construction will help to compensate for some of the lost vegetation and contribute to urban green space.

1.5 Decreased Human Health Due to Increased Noise During Construction

- .1 The following mitigation measures are required to decrease the effects of noise generated during construction:
 - .1 All City by-laws and Provincial legislation pertaining to noise produced by construction shall be followed.
 - .2 All construction equipment and vehicles shall be inspected and maintained for maximum noise suppression.

- .3 All workers at the construction site shall use proper equipment to protect themselves from loud noise.
- .4 Vehicles and equipment shall not be left running or operating if not in use.
- .5 No construction tools or equipment may be operated on Sundays or on weekdays between the hours of 10:00 PM and 7:00 AM the following day or on Saturdays and statutory holidays before 9:00 AM and after 9:00 PM.

1.6 Standard Construction Mitigation Measures

- .1 Standard mitigation measures must be followed during construction:
 - .1 No refueling or servicing of construction equipment within 100m of a water body.
 - .2 Propose collection and disposal of waste oil products from construction equipment in accordance with the laws of the Province of the Work.
 - .3 Proper collection and disposal of all construction wastes from the construction site.
 - .4 Use, handling and storage of fuels and petroleum products in accordance with Manitoba Regulation MR 188/2001.
 - .5 Contractor shall have spill clean-up materials on site with a minimum of 25kg of suitable commercial sorbent, 30 square meters of 8 mil polyethylene, and an empty fuel barrel for spill collection and disposal (CPWCC 1999).
 - .6 Notification of Contract Administrator and Manitoba Conservation in the event of any spills of petroleum products or hazardous materials in accordance with Manitoba regulations (MR 439/87).
 - .7 Construction equipment shall be properly maintained to prevent leaks and spills of fuels, lubricants, hydraulic fluids, or coolants.
 - .8 Topsoil shall be conserved by removal and stockpiling prior to construction.
 - .9 Use effective dust suppressant such as water, covering stockpiled materials, covering truck loads and restricting activities during high wind events.
 - .10 Ensure adequate ventilation and filtering systems and using effective dust control agents, such as water.
 - .11 Using low VOC – containing building materials where available.
 - .12 Minimize the frequency and duration of vibration – causing activities.
 - .13 Periodic inspection of the project site and adjacent buildings for vibration levels and associated damage.
 - .14 Measurement of vibration if levels appear high and adherence to Contract specifications.

- .15 Stockpile topsoil apart from and not mixing with the underlying materials and using excavated material on-site.
- .16 Preventing contact of hazardous material with soil.
- .17 Prepare an emergency spill response plan.

PART 2 PRODUCTS

2.1 Not Used

- .1 Not Used.

PART 3 EXECUTION

3.1 Not Used

- .1 Not Used.

END OF SECTION

PART 1 GENERAL

1.1 Section Includes

- .1 Title and description of Work.
- .2 Contract Method.
- .3 Work by others.
- .4 Contractor use of premises.
- .5 Partial City occupancy.
- .6 City furnished items.

1.2 Work Covered by Contract Documents

- .1 Work of this Contract comprises general construction of a community centre, located at the intersection of Murray Ave and Main St. in Winnipeg, MB; and further identified as Red River Community Centre, 293 Murray Ave.

1.3 Work by Others

- .1 Work of Project which will be executed after completion of Work of this Contract, and which is specifically excluded from this Contract:
 - .1 Furniture.
 - .2 Playgrounds

1.4 Contractor Use of Premises

- .1 Contractor has unrestricted use of site until Substantial Performance.

1.5 City Furnished Items

- .1 City supplied Items:
 - .1 Liquid soap dispensers.
 - .2 Toilet paper dispensers.
 - .3 Wooden timber beams and timber columns as indicated on drawings at Vestibule 101 entry and at tower. Contractor to do all necessary preparations prior to installation. Coordinate selection of beams and columns from available supply with Contract Administrator and Structural Engineer. Existing painted salvaged timbers to be refurbished to Construction Administrator approval prior to installation. This includes the pick up (from City of Winnipeg storage location at 1500 Plessis Road) and delivery to necessary locations for the sandblasting of the timbers to Contract Administrator's approval, and the cutting of timbers to the required lengths, delivery to the project site, and finishing as per Sections 09911 and 09912. Refer to Section 06201.

- .2 City Responsibilities:
 - .1 Arrange for delivery of shop drawings, product data, samples, manufacturer's instructions, and certificates to Contractor.
 - .2 Deliver supplier's bill of materials to Contractor.
 - .3 Arrange and pay for delivery to site in accordance with Progress Schedule.
 - .4 Inspect deliveries jointly with Contractor.
 - .5 Submit claims for transportation damage.
 - .6 Arrange for replacement of damaged, defective or missing items.
 - .7 Arrange for manufacturer's field services; arrange for and deliver manufacturer's warranties and bonds to Contractor.
- .3 Contractor Responsibilities:
 - .1 Designate submittals and delivery date for each product in progress schedule.
 - .2 Review shop drawings, product data, samples, and other submittals. Submit to Contract Administrator notification of any observed discrepancies or problems anticipated due to non-conformance with Contract Documents.
 - .3 Receive and unload products at site.
 - .4 Inspect deliveries jointly with City; record shortages, and damaged or defective items.
 - .5 Handle products at site, including uncrating and storage.
 - .6 Protect products from damage, and from exposure to elements.
 - .7 Assemble, install, connect, adjust, and finish products.
 - .8 Provide installation inspections required by public authorities.
 - .9 Repair or replace items damaged by Contractor or Sub trade on site (under his control).

PART 2 PRODUCTS

2.1 Not Used

- .1 Not used.

PART 3 EXECUTION

3.1 Not Used

- .1 Not used.

END OF SECTION

PART 1 GENERAL

1.1 Section Includes

- .1 Shop drawings and product data.
- .2 Samples.

1.2 Related Sections

- .1 Section 01450 - Quality Control.
- .2 Section 01780 - Closeout Submittals.

1.3 Administrative

- .1 Submit to Contract Administrator submittals listed for review. Submit with reasonable promptness and in orderly sequence so as to not cause delay in Work. Failure to submit in ample time is not considered sufficient reason for an extension of Contract Time and no claim for extension by reason of such default will be allowed.
- .2 Work affected by submittal shall not proceed until review is complete.
- .3 Present shop drawings, product data, samples and mock-ups in SI Metric units.
- .4 Where items or information is not produced in SI Metric units converted values are acceptable.
- .5 Review submittals prior to submission to Contract Administrator. This review represents that necessary requirements have been determined and verified, or will be, and that each submittal has been checked and co-ordinated with requirements of Work and Contract Documents. Submittals not stamped, signed, dated and identified as to specific project will be returned without being examined and shall be considered rejected.
- .6 Notify Contract Administrator, in writing at time of submission, identifying deviations from requirements of Contract Documents stating reasons for deviations.
- .7 Verify field measurements and affected adjacent Work are coordinated.
- .8 Contractor's responsibility for errors and omissions in submission is not relieved by Contract Administrator's review of submittals.
- .9 Contractor's responsibility for deviations in submission from requirements of Contract Documents is not relieved by Contract Administrator review.
- .10 Keep one reviewed copy of each submission on site.

1.4 Shop Drawings and Product Data

- .1 Refer to CCDC-2-1994.

- .2 The term "shop drawings" means drawings, diagrams, illustrations, schedules, performance charts, brochures and other data which are to be provided by Contractor to illustrate details of a portion of Work.
- .3 Indicate materials, methods of construction and attachment or anchorage, erection diagrams, connections, explanatory notes and other information necessary for completion of Work. Where articles or equipment attach or connect to other articles or equipment, indicate that such items have been coordinated, regardless of Section under which adjacent items will be supplied and installed. Indicate cross references to design drawings and specifications.
- .4 Allow 7 days for Contract Administrator's review of each submission.
- .5 Adjustments made on shop drawings by Contract Administrator are not intended to change Contract Price. If adjustments affect value of Work, state such in writing to Contract Administrator prior to proceeding with Work.
- .6 Make changes in shop drawings as Contract Administrator may require, consistent with Contract Documents. When resubmitting, notify Contract Administrator in writing of any revisions other than those requested.
- .7 Accompany submissions with transmittal letter, containing:
 - .1 Date.
 - .2 Project title and number.
 - .3 Contractor's name and address.
 - .4 Identification and quantity of each shop drawing, product data and sample.
 - .5 Other pertinent data.
- .8 Submissions shall include:
 - .1 Date and revision dates.
 - .2 Project title and number.
 - .3 Name and address of:
 - .1 Subtrade.
 - .2 Supplier.
 - .3 Manufacturer.
 - .4 Contractor's stamp, signed by Contractor's authorized representative certifying approval of submissions, verification of field measurements and compliance with Contract Documents.
 - .5 Details of appropriate portions of Work as applicable:
 - .1 Fabrication.
 - .2 Layout, showing dimensions, including identified field dimensions, and clearances.
 - .3 Setting or erection details.

- .4 Capacities.
- .5 Performance characteristics.
- .6 Standards.
- .7 Operating weight.
- .8 Wiring diagrams.
- .9 Single line and schematic diagrams.
- .10 Relationship to adjacent Work.
- .9 After Contract Administrator's review, distribute copies.
- .10 Submit 6 prints of shop drawings for each requirement requested in specification Sections and as Contract Administrator may reasonably request.
- .11 Submit 6 hardcopy or electronic copies of product data sheets or brochures for requirements requested in specification Sections and as requested by Contract Administrator where shop drawings will not be prepared due to standardized manufacture of product.
- .12 Delete information not applicable to project.
- .13 Supplement standard information to provide details applicable to project.
- .14 If upon review by Contract Administrator, no errors or omissions are discovered or if only minor corrections are made, copies will be returned and fabrication and installation of Work may proceed. If shop drawings are rejected, noted copy will be returned and resubmission of corrected shop drawings, through same procedure indicated above, must be performed before fabrication and installation of Work may proceed.

1.5 Samples

- .1 Submit for review samples in duplicate as requested in respective specification Sections. Label samples with origin and intended use.
- .2 Deliver samples prepaid to Contract Administrator's business address.
- .3 Notify Contract Administrator in writing, at time of submission of deviations in samples from requirements of Contract Documents.
- .4 Where colour, pattern or texture is criterion, submit full range of samples.
- .5 Adjustments made on samples by Contract Administrator are not intended to change Contract Price. If adjustments affect value of Work, state such in writing to Contract Administrator prior to proceeding with Work.
- .6 Make changes in samples which Contract Administrator may require, consistent with Contract Documents.
- .7 Reviewed and accepted samples will become standard of workmanship and material against which installed Work will be verified.

PART 2 PRODUCTS

2.1 Not Used

.1 Not Used.

PART 3 EXECUTION

3.1 Not Used

.1 Not Used.

END OF SECTION

PART 1 GENERAL

1.1 Section Includes

- .1 List significant generic types of products, Work, or requirements specified. Do not include procedure, process, preparatory Work, or final adjusting and cleaning. Include Waste Audit, Waste Reduction Workplan, Materials Source Separation Program, and Cost/Revenue Analysis Workplan.

1.2 Definitions

- .1 Waste Audit (WA): Relates to projected waste generation. Involves measuring and estimating quantity and composition of waste, reasons for waste generation, and operational factors which contribute to waste.
- .2 Waste Reduction Workplan (WRW): Written report which addresses opportunities for reduction, reuse, or recycling of materials. WRW is based on information acquired from WA (Schedule A).
- .3 Demolition Waste Audit (DWA): Relates to actual waste generated from project.
- .4 Materials Source Separation Program (MSSP): Consists of a series of ongoing activities to separate reusable and recyclable waste material into material categories from other types of waste at point of generation.
- .5 Cost/Revenue Analysis Workplan (CRAW): Based on information from WRW, and intended as financial tracking tool for determining economic status of waste management practices.
- .6 Waste Management Coordinator (WMC): Designate individual who is in attendance on-site, full-time. Designate, or have designated, individuals from each Subtrade to be responsible for waste management related to their trade and for coordinating activities with WMC.
- .7 Separate Condition: Refers to waste sorted into individual types.

1.3 Documents

- .1 Maintain at job site, one copy of following documents:
 - .1 Waste Audit
 - .2 Waste Reduction Workplan
 - .3 Material Source Separation Plan
 - .4 Schedules A, B, and E completed for project.

1.4 Submittal

- .1 Submit requested submittals in accordance with Section 01330 - Submittal Procedures.
- .2 Prepare and submit the following submittals prior to project start-up:

- .1 Submit 1 copy of completed Waste Audit (WA): Schedule A.
- .2 Submit 1 copy of completed Waste Reduction Workplan (WRW): Schedule B.
- .3 Submit 1 copy of Materials Source Separation Program description.

1.5 Waste Audit

- .1 Conduct WA prior to project start-up.
- .2 Prepare Waste Audit: Schedule A.
- .3 Record, on Waste Audit - Schedule A, extent to which materials or products used consist of recycled or reused materials or products.

1.6 Waste Reduction Workplan

- .1 Prepare WRW prior to project start-up.
- .2 Structure WRW to prioritize actions and follow 3R's hierarchy, with Reduction as first priority, followed by Reuse, then Recycle.
- .3 Describes management of waste.
- .4 Identify opportunities for reduction, reuse, and/or recycling (3Rs) of materials. Based on information acquired from WA.
- .5 Post Workplan or summary where workers at site are able to review its content.

1.7 Materials Source Separation Program

- .1 Prepare MSSP and have ready for use prior to project start-up.
- .2 Implement MSSP for waste generated on project in compliance with approved methods and as approved by Contract Administrator.
- .3 Provide on-site facilities for collection, handling, and storage of anticipated quantities of reusable and/or recyclable materials.
- .4 Provide containers to deposit reusable and/or recyclable materials.
- .5 Locate containers in locations, to facilitate deposit of materials without hindering daily operations.
- .6 Locate separated materials in areas which minimize material damage.
- .7 Collect, handle, store on-site, and transport off-site, salvaged materials in separate condition. Transport to approved and authorized recycling facility or to users of material for recycling.
- .8 Collect, handle, store on-site, and transport off-site, salvaged materials in combined condition. Ship materials to approved locations. Materials must be immediately separated into required categories for reuse or recycling.

1.8 Disposal of Wastes

- .1 Burying of rubbish and waste materials is prohibited unless approved by Contract Administrator.
- .2 Disposal of waste, volatile materials, mineral spirits, oil, paint thinner, or paint into waterways, storm, or sanitary sewers is prohibited.

1.9 Storage, Handling and Protection

- .1 Unless specified otherwise, materials for removal do not become Contractor's property.
- .2 Protect, stockpile, and store salvaged items.
- .3 Separate non-salvageable materials from salvaged items. Transport and deliver non-salvageable items to licensed disposal facility.

1.10 Scheduling

- .1 Coordinate Work with other activities at site to ensure timely and orderly progress of the Work.

PART 2 PRODUCTS

2.1 Not Used

- .1 Not Used.

PART 3 EXECUTION

3.1 Application

- .1 Do Work in compliance with WRW.
- .2 Handle waste materials not reused, salvaged, or recycled in accordance with appropriate regulations and codes.

3.2 Cleaning

- .1 Remove tools and waste materials on completion of Work, and leave Work area in clean and orderly condition.
- .2 Clean-up Work area as Work progresses.
- .3 Source separate materials to be reused/recycled into specified sort areas.

3.3 Diversion of Materials

- .1 From following list, separate materials from general waste stream and stockpile in separate piles or containers, to approval of Contract Administrator, and consistent with applicable fire regulations. Mark containers or stockpile areas. Provide instruction on disposal practices.

.2 On-site sale of reusable or recyclable materials is not permitted.

.3 Construction Waste

| Material Type | Recommended Diversion % | Actual Diversion % |
|---------------|-------------------------|--------------------|
| Cardboard | 100 | |
| Steel | 100 | |

3.4 Waste Reduction Workplan

.1 Schedule B

| (1) Material Category | (2) Person(s) Responsible | (3) Total Quantity of Waste (unit) | (4) Reused Amount (units) Projected | Actual | (5) Recycled Amount (unit) Projected | Actual | (6) Material (s) Destination |
|-----------------------|---------------------------|------------------------------------|-------------------------------------|--------|--------------------------------------|--------|------------------------------|
| | | | | | | | |
| Cardboard Packaging | | | | | | | |
| Wood | | | | | | | |
| Metal | | | | | | | |

3.5 Canadian Governmental Departments Chief Responsibility for the Environment

.1 Schedule E

| Province | Address | General Inquires | Fax |
|----------|--|------------------|----------------|
| Manitoba | Manitoba Environment Building 2, 139 Tuxedo Avenue Winnipeg, MB R3N 0H6 | (204) 945-7100 | |
| | The Clean Environment Commission 284 Reimer Avenue Box 21420 Steinbach, MB R0A 2T3 | (204) 326-2395 | (204) 326-2472 |

END OF SECTION

PART 1 GENERAL

1.1 Associations

- .1 AA - Aluminum Association, 900 19th Street N.W., Washington, D.C., U.S.A. 20006 URL <http://www.aluminum.org>
- .2 AASHTO - American Association of State Highway and Transportation Officials, 444 N Capitol Street N.W., Suite 249, Washington, D.C., U.S.A. 20001 URL <http://www.aashto.org>
- .3 ACEC Association of Consulting Engineers of Canada, 130 Albert Street, Ottawa, ON. K1P 5G4 URL <http://www.acec.ca>
- .4 AHA - American Hardboard Association, 1210W Northwest Hwy., Palatine, Illinois, U.S.A. 60067 URL : <http://www.areas.com>
- .5 AITC - American Institute of Timber Construction, 7012 S. Revere Parkway, Suite 140, Englewood, Colorado, U.S.A. 80112 URL <http://www.aitc-glulam.org>
- .6 AMCA - Air Movement and Control Association Inc., 30 West University Drive, Arlington Heights, Illinois, U.S.A. 60004-1893 URL <http://www.amca.org>
- .7 ANSI - American National Standards Institute, 11 West 42nd Street, New York, New York, U.S.A. 10036 URL <http://www.ansi.org>
- .8 APA - The Engineered Wood Association, P.O. Box 11700, Tacoma, Washington, U.S.A. 98411-0700 URL <http://www.apawood.org>
- .9 API - American Petroleum Institute, 1220 L St. Northwest, Washington, D.C., U.S.A. 20005-4070 URL <http://www.api.org>
- .10 ARI - Air Conditioning and Refrigeration Institute, 4301 North Fairfax Drive, Suite 425, Arlington, Virginia, U.S.A. 22203 URL <http://www.ari.org>
- .11 ASHRAE - American Society of Heating, Refrigeration and Air-Conditioning Engineers, 1791 Tullie Circle NE, Atlanta, Georgia, U.S.A. 30329 URL <http://www.ashrae.org>
- .12 ASME - American Society of Mechanical Engineers, United Engineering Centre, Three Park Avenue, New York, New York, U.S.A. 10016-5990 URL <http://www.asme.org>
- .13 ASPT Association for Asphalt Paving Technologists, 400 Selby Avenue, Suite 1, St. Paul, MN 55102 U.S.A. URL <http://www.asphalt.org>
- .14 ASTM - American Society for Testing and Materials, 100 Barr Harbor Drive West, Conshohocken, Pennsylvania 19428-2959 URL <http://www.astm.org>
- .15 AWCI - Association of the Wall and Ceiling Industries International, 803 West Broad Street, Suite 600, Falls Church, VA, U.S.A. 22046 URL <http://www.awci.org>

- .16 AWMAC - Architectural Woodwork Manufacturers Association of Canada, 516 4 Street West, High River, Alberta T1V 1B6 URL <http://www.awmac.com>
- .17 AWPA - American Wire Producer's Association, 6232 Roudsby, Alexandria, VA U.S.A. 22315-5285 URL <http://www.awpa.org>
- .18 AWPA - American Wood Preservers' Association, P.O. Box 5690, Grandbury Texas, U.S.A. 76049-0690 URL <http://www.awap.com>
- .19 AWS - American Welding Society, 550 N.W. LeJeune Road, Miami, Florida U.S.A. 33126 URL <http://www.amweld.org>
- .20 AWWA - American Water Works Association, 6666 W. Quincy Avenue, Denver, Colorado, U.S.A. 80235 URL <http://www.awwa.org>
- .21 CCA Canadian Construction Association, 75 Albert St., Suite 400 Ottawa, Ontario, K1P 5E7 URL <http://www.cca-acc.com>
- .22 CCDC Canadian Construction Documents Committee, Refer to ACEC, CCA, CSC or RAIC
- .23 CITC Canadian Institute of Timber Construction, 200 Cooper Street, Ottawa, Ontario K2P 0G1
- .24 CFFM - Canadian Forces Fire Marshal, 101 Colonel By Drive, 8NT MGen George R. Pearkes Bldg., Ottawa, Ontario K1A 0K2
- .25 CGA - Canadian Gas Association, 20 Eglinton Avenue West, Suite 1305, Toronto, Ontario M4R 1K8 URL <http://www.cga.ca>
- .26 CGSB - Canadian General Standards Board, Place du Portage, Phase III, 6B1, 11 Laurier Street, Hull, Quebec K1A 1G6 URL <http://w3.pwgsc.gc.ca/cgsb>
- .27 CISC - Canadian Institute of Steel Construction, 201 Consumers Road, Suite 300, Willowdale, Ontario M2J 4G8 URL <http://www.buildingweb.com/CISC>
- .28 CLA - Canadian Lumbermen's Association, 27 Goulburn Avenue, Ottawa, Ontario, K1N 8C7 URL <http://www.cla.ca.ca>
- .29 CNLA - Canadian Nursery Landscape Association, RR #4, Stn. Main, 7856 Fifth Street, Milton, Ontario. L9T 2X8 URL <http://www.canadanursery.com>
- .30 CRCA - Canadian Roofing Contractors Association, 155 Queen Street, Suite 130C, Ottawa, Ontario K1P 6L1 URL <http://www.roofingcanada.com>
- .31 CSA - Canadian Standards Association International, 178 Rexdale Blvd., Toronto, Ontario M9W 1R3 URL <http://www.csa-international.org>
- .32 CSC - Construction Specifications Canada, 100 Lombard Street, Suite 200, Toronto, Ontario M5C 1M3 URL <http://www.csc-dcc.ca>
- .33 CSDFMA - Canadian Steel Door and Frame Manufacturing Association One Yonge Street, Suite 1400, Toronto, Ontario M5E 1J9

- .34 CSPI - Corrugated Steel Pipe Institute, 201 Consumers Road, Suite 306, Willowdale, Ontario M2J 4G8
- .35 CSSBI - Canadian Sheet Steel Building Institute, 652 Bishop St. N., Unit 2A, Cambridge, Ontario N3H 4V6 URL <http://www.cssbi.ca>
- .36 CUFCA Canadian Urethane Foam Contractor's Association
- .37 CWC - Canadian Wood Council, 1400 Blair Place, Suite 210, Ottawa, Ontario K1J 9B8 URL <http://www.cwc.ca>
- .38 EC - Environment Canada, Conservation and Protection, Ottawa, Ontario KIA 0H3 URL <http://www.ec.gc.ca>
- .39 EEMAC - Electrical and Electronic Manufacturers' Association of Canada, 5800 Explorer Drive, Suite 200, Mississauga, Ontario L4W 5K9 URL <http://www.electrofed.ca>
- .40 EIMA EIFS Industry Manufacturer's Association, 3000 Corporate Center Drive, Suite 270, Morrow, Georgia U.S.A. 30260 URL <http://www.eifsfacts.com>
- .41 FCC - Fire Commissioner of Canada, Place du Portage, Phase II, 165 rue Hotel de Ville, Hull Quebec K1A 0J2 URL <http://www.hrdc-drhc.gc.ca>
- .42 IEEE - Institute of Electrical and Electronics Engineers, 345 East 47th Street, New York, New York U.S.A. 10017 URL <http://www.ieee.org>
- .43 MPI - The Master Painters Institute, 4090 Graveley Street, Burnaby, BC V5C 3T6 URL <http://www.paintinfo.com>
- .44 MSS - Manufacturers Standardization Society of the Valve and Fittings Industry, 127 Park Street, N.E., Vienna, Virginia U.S.A.22180
- .45 NAAMM - National Association of Architectural Metal Manufacturers, 8 South Michigan Avenue, Suite 1000, Chicago, Illinois U.S.A. 60603 URL <http://www.naamm.org>
- .46 NABA - National Air Barrier Association, 400-283 Bannatyne Avenue, Winnipeg, Manitoba R3B 3B2
- .47 NEMA - National Electrical Manufacturers Association, 1300 N. 17th Street, Suite 1847, Rosslyn, Virginia 22209 URL <http://www.nema.org>
- .48 NFPA - National Fire Protection Association, 1 Batterymarch Park, P.O. Box 9101Quincy, Massachusetts, U.S.A. 02269-9101 URL <http://www.nfpa.org>
- .49 NFSa - National Fire Sprinkler Association, 40 Jon Barrett Road, P.O. Box 1000, Patterson, New York, U.S.A. 12563 URL <http://www.nfsa.org>
- .50 NHLA - National Hardwood Lumber Association, P.O. Box 34518, Memphis, Tennessee, U.S.A 38184-0518 URL <http://www.natlhardwood.org>

- .51 NLGA - National Lumber Grades Authority, 406 First Capital Place, New Westminster, B.C. V3M 6G2
- .52 NRC - National Research Council, Montreal Road, Ottawa, Ontario K1A 0S2
URL <http://www.nrc.gc.ca>
- .53 NSPE National Society of Professional Engineers, 1420 King Street, Alexandria, VA U.S.A. 22314-2794 URL <http://www.nspe.org>
- .54 QPL - Qualification Program List, c/o Canadian General Standards Board, Place du Portage, Phase III, 6B1, 11 Laurier Street, Hull, Quebec K1A 1G6 URL <http://www.pwgsc.gc.ca/cgsb>
- .55 RAIC Royal Architectural Institute of Canada, 55 Murray Street, Suite 330, Ottawa, Ontario, K1N 5M3 URL <http://www.raic.org>
- .56 SCC - Standards Council of Canada, 200 Albert Street, Suite 2000, Ottawa, Ontario K1P 6N7 URL <http://www.scc.ca>
- .57 SSPC - The Society for Protective Coatings, 40 24th Street, Pittsburgh, Pennsylvania 15222-4656 URL <http://www.sspc.org>
- .58 TPI - Truss Plate Institute, 583 D'Onofrio Drive, Suite 200, Madison, WI, U.S.A. 53719 URL <http://www.tpinst.org>
- .59 UL - Underwriters' Laboratories, 333 Pfingsten Road, Northbrook, Illinois, U.S.A. 60062 URL <http://www.ul.com>
- .60 ULC - Underwriters' Laboratories of Canada, 7 Crouse Road, Toronto, Ontario M1R 3A9 URL <http://www.ulc.ca>

PART 2 PRODUCTS

2.1 Not Used

- .1 Not Used.

PART 3 EXECUTION

3.1 Not Used

- .1 Not Used.

END OF SECTION

PART 1 GENERAL

1.1 Section Includes

- .1 Inspection and testing, administrative and enforcement requirements.
- .2 Tests and mix designs.
- .3 Mock-ups.
- .4 Mill tests.
- .5 Equipment and system adjust and balance.

1.2 Related Sections

- .1 Section 01330 - Submittal Procedures.
- .2 Section 01420 - References.
- .3 Section 01780 - Closeout Submittals.

1.3 Inspection

- .1 Allow Contract Administrator access to Work. If part of Work is in preparation at locations other than Place of Work, allow access to such Work whenever it is in progress.
- .2 Give timely notice requesting inspection if Work is designated for special tests, inspections or approvals by Contract Administrator instructions, or law of Place of Work.
- .3 If Contractor covers or permits to be covered Work that has been designated for special tests, inspections or approvals before such is made, uncover such Work, have inspections or tests satisfactorily completed and make good such Work.
- .4 Contract Administrator may order any part of Work to be examined if Work is suspected to be not in accordance with Contract Documents. If, upon examination such Work is found not in accordance with Contract Documents, correct such Work and pay cost of examination and correction. If such Work is found in accordance with Contract Documents, Contract Administrator shall pay cost of examination and replacement.

1.4 Independent Inspection Agencies

- .1 Independent Inspection/Testing Agencies will be engaged by Contract Administrator for purpose of inspecting and/or testing portions of Work. Cost of such services will be borne by the City.
- .2 Employment of inspection/testing agencies does not relax responsibility to perform Work in accordance with Contract Documents.

- .3 If defects are revealed during inspection and/or testing, appointed agency will request additional inspection and/or testing to ascertain full degree of defect. Correct defect and irregularities as advised by Contract Administrator at no cost to the City. Contractor to pay costs for retesting and re-inspection.

1.5 Access to Work

- .1 Allow inspection/testing agencies access to Work, off site manufacturing and fabrication plants.
- .2 Co-operate to provide reasonable facilities for such access.

1.6 Procedures

- .1 Notify appropriate agency and Contract Administrator in advance of requirement for tests, in order that attendance arrangements can be made.
- .2 Submit samples and/or materials required for testing, as specifically requested in specifications. Submit with reasonable promptness and in an orderly sequence so as not to cause delay in Work.
- .3 Provide labour and facilities to obtain and handle samples and materials on site. Provide sufficient space to store and cure test samples.

1.7 Rejected Work

- .1 Remove defective Work, whether result of poor workmanship, use of defective products or damage and whether incorporated in Work or not, which has been rejected by Contract Administrator as failing to conform to Contract Documents. Replace or re-execute in accordance with Contract Documents.
- .2 Make good other Contractor's Work damaged by such removals or replacements promptly.
- .3 If in opinion of Contract Administrator it is not expedient to correct defective Work or Work not performed in accordance with Contract Documents, the City may deduct from Contract Price difference in value between Work performed and that called for by Contract Documents, amount of which shall be determined by Contract Administrator.

1.8 Reports

- .1 Submit 2 copies of inspection and test reports to Contract Administrator.
- .2 Provide copies to Subtrade of Work being inspected or tested or manufacturer or fabricator of material being inspected or tested.

1.9 Tests and Mix Designs

- .1 Furnish test results and mix designs as may be requested.

- .2 The cost of tests and mix designs beyond those called for in Contract Documents or beyond those required by law of Place of Work shall be appraised by Contract Administrator and may be authorized as recoverable.

1.10 Mock-ups

- .1 Prepare mock-ups for Work specifically requested in specifications. Include for Work of all Sections required to provide mock-ups.
- .2 Prepare mock-ups for Contract Administrator's review with reasonable promptness and in an orderly sequence, so as not to cause any delay in Work.
- .3 Failure to prepare mock-ups in ample time is not considered sufficient reason for an extension of Contract Time and no claim for extension by reason of such default will be allowed.
- .4 If requested, Contract Administrator will assist in preparing a schedule fixing dates for preparation.
- .5 Remove mock-up at conclusion of Work or when acceptable to Contract Administrator.
- .6 Mock-ups may remain as part of Work as approved by Contract Administrator.

1.11 Mill Tests

- .1 Submit mill test certificates as required of specification Sections.

1.12 Equipment and Systems

- .1 Submit adjustment and balancing reports for mechanical, electrical and building equipment systems.

PART 2 PRODUCTS

2.1 Not Used

- .1 Not Used.

PART 3 EXECUTION

3.1 Not Used

- .1 Not Used.

END OF SECTION

PART 1 GENERAL

1.1 Section Includes

- .1 Temporary utilities.

1.2 Related Sections

- .1 Section 01520 - Construction Facilities.
- .2 Section 01560 - Temporary Barriers and Enclosures.

1.3 Installation and Removal

- .1 Provide temporary utilities controls in order to execute Work expeditiously.
- .2 Remove from site all such Work after use.

1.4 Dewatering

- .1 Provide temporary drainage and pumping facilities to keep excavations and site free from standing water.

1.5 Water Supply

- .1 Contractor to provide continuous supply of potable water for construction use.
- .2 Arrange for connection with appropriate utility company and pay all costs for installation, maintenance and removal.

1.6 Temporary Heating and Ventilation

- .1 Provide temporary heating required during construction period, including attendance, maintenance and fuel.
- .2 Construction heaters used inside building must be vented to outside or be non-flameless type. Solid fuel salamanders are not permitted.
- .3 Provide temporary heat and ventilation in enclosed areas as required to:
 - .1 Facilitate progress of Work.
 - .2 Protect Work and products against dampness and cold.
 - .3 Prevent moisture condensation on surfaces.
 - .4 Provide ambient temperatures and humidity levels for storage, installation and curing of materials.
 - .5 Provide adequate ventilation to meet health regulations for safe working environment.
- .4 Maintain temperatures of minimum 10 degrees C in areas where construction is in progress.

- .5 Ventilating:
 - .1 Prevent accumulations of dust, fumes, mists, vapours or gases in areas occupied during construction.
 - .2 Provide local exhaust ventilation to prevent harmful accumulation of hazardous substances into atmosphere of occupied areas.
 - .3 Dispose of exhaust materials in manner that will not result in harmful exposure to persons.
 - .4 Ventilate storage spaces containing hazardous or volatile materials.
 - .5 Continue operation of ventilation and exhaust system for time after cessation of Work process to assure removal of harmful contaminants.
- .6 Permanent building heating system may be used when available, upon Contract Administrator's approval. Be responsible for damage to heating system if use is permitted.
- .7 On completion of Work for which permanent heating system is used, replace all filters.
- .8 Ensure Date of Total Performance and Warranties for heating system do not commence until entire system is in as near original condition as possible and is certified by Contract Administrator.
- .9 Maintain strict supervision of operation of temporary heating and ventilating equipment to:
 - .1 Conform with applicable codes and standards.
 - .2 Enforce safe practices.
 - .3 Prevent abuse of services.
 - .4 Prevent damage to finishes.
 - .5 Vent direct-fired combustion units to outside.
- .10 Be responsible for damage to Work due to failure in providing adequate heat and protection during construction.

1.7 Temporary Power and Light

- .1 Provide and pay for temporary power during construction for temporary lighting and operating of power tools, to a maximum supply of 230 volts 30 amps.
- .2 Arrange for connection with appropriate utility company. Pay all costs for installation, maintenance and removal.
- .3 Temporary power for electric cranes and other equipment requiring in excess of above is responsibility of Contractor.
- .4 Provide and maintain temporary lighting throughout project. Ensure level of illumination on all floors and stairs is not less than 162 lx.

- .5 Electrical power and lighting systems installed under this Contract may be used for construction requirements only with prior approval of Contract Administrator provided that guarantees are not affected. Make good damage to electrical system caused by use under this Contract. Replace lamps which have been used for more than 3 months.

1.8 Temporary Communication Facilities

- .1 Provide and pay for temporary telephone and fax hook up, lines and equipment necessary for own use and use of Contract Administrator.

1.9 Fire Protection

- .1 Provide and maintain temporary fire protection equipment during performance of Work required by insurance companies having jurisdiction and governing codes, regulations and bylaws.
- .2 Burning rubbish and construction waste materials is not permitted on site.

PART 2 PRODUCTS

2.1 Not Used

- .1 Not Used.

PART 3 EXECUTION

3.1 Not Used

- .1 Not Used.

END OF SECTION

PART 1 GENERAL

1.1 Section Includes

- .1 Construction aids.
- .2 Office and sheds.
- .3 Parking.
- .4 Project identification.

1.2 Related Sections

- .1 Section 01510 - Temporary Utilities.
- .2 Section 01560 - Temporary Barriers and Enclosures.

1.3 References

- .1 Canadian Standards Association (CSA)
 - .1 CAN3-A23.1-/A23.2-94, Concrete Materials and Methods for Concrete Construction/Method of Test for Concrete.
 - .2 CSA-0121-M1978, Douglas Fir Plywood.
 - .3 CAN/CSA-Z321-96, Signs and Symbols for the Occupational Environment.

1.4 Installation and Removal

- .1 Provide construction facilities in order to execute Work expeditiously.
- .2 Remove from site all such Work after use.

1.5 Scaffolding

- .1 Provide and maintain scaffolding as required.

1.6 Site Storage/Loading

- .1 Confine Work and operations of employees by Contract Documents. Do not unreasonably encumber premises with products.
- .2 Do not load or permit to load any part of Work with a weight or force that will endanger the Work.

1.7 Construction Parking

- .1 Parking will be permitted on site provided it does not disrupt performance of Work and any damage to property is repaired.
- .2 Provide and maintain adequate access to project site.

- .3 Provide snow removal during period of Work as required.

1.8 Security

- .1 Be responsible for security to site and contents of site after working hours and during holidays.

1.9 Offices

- .1 Provide office heated to 22 °C, lighted 750 lx and ventilated, of sufficient size to accommodate site meetings and furnished with drawing lay down table.
- .2 Provide a clearly marked and fully stocked first-aid case in a readily available location.
- .3 Sub-trades may provide their own offices as necessary. Direct location of these offices.

1.10 Equipment, Tool and Materials Storage

- .1 Provide and maintain, in a clean and orderly condition, lockable weatherproof sheds for storage of tools, equipment and materials.
- .2 Locate materials not required to be stored in weatherproof sheds on site in a manner to cause least interference with Work activities.

1.11 Sanitary Facilities

- .1 Provide sanitary facilities for Work force in accordance with governing regulations and ordinances.
- .2 Post notices and take such precautions as required by local health authorities. Keep area and premises in sanitary condition.
- .3 When permanent water and drain connections are completed, provide temporary water closets and urinals complete with temporary enclosures, inside building. Permanent facilities may be used on approval of Contract Administrator.

1.12 Construction Signage

- .1 Provide and erect, within three weeks of award Contract, a project sign in a location designated by Contract Administrator.
- .2 Construction sign 1.2 x 2.4 m, of wood frame and plywood construction painted with exhibit lettering produced by a professional sign painter.
- .3 Indicate on sign, name of City of Winnipeg, Province of Manitoba, Government of Canada, and Contract Administrator, of a design style approved by Contract Administrator.
- .4 No other signs or advertisements, other than warning signs, are permitted on site.

- .5 Locate project identification sign as directed by Contract Administrator and construct as follows:
 - .1 Build concrete foundation, erect framework, and attach signboard to framing.
 - .2 Paint all surfaces of signboard and framing with one coat primer and two coats enamel. Colour white on signboard face, black on other surfaces.
 - .3 Apply vinyl sign face overlay to painted signboard face in accordance with installation instruction supplied.
- .6 Direct all requests for approval to erect a Contractor signboard to Contract Administrator. For consideration general appearance of Contract Administrator/Contractor signboard must conform to project identification site sign. Wording shall be in both official languages.
- .7 Signs and notices for safety and instruction shall be in both official languages Graphic symbols shall conform to CAN3-Z321.
- .8 Maintain approved signs and notices in good condition for duration of project, and dispose of off site on completion of project or earlier if directed by Contract Administrator.

PART 2 PRODUCTS

2.1 Not Used

- .1 Not Used.

PART 3 EXECUTION

3.1 Not Used

- .1 Not Used.

END OF SECTION

PART 1 GENERAL

1.1 Section Includes

- .1 Barriers.
- .2 Environmental Controls.

1.2 Related Sections

- .1 Section 01510 - Temporary Utilities.
- .2 Section 01520 - Construction Facilities.

1.3 References

- .1 Canadian General Standards Board (CGSB)
 - .1 CGSB 1.189M-84, Primer, Alkyd, Wood, Exterior.
 - .2 CGSB 1.59-97, Alkyd Exterior Gloss Enamel.
- .2 Canadian Standards Association (CSA)
 - .1 CSA-O121-M1978, Douglas Fir Plywood.

1.4 Installation and Removal

- .1 Provide temporary controls in order to execute Work expeditiously.
- .2 Remove from site all such Work after use.

1.5 Hoarding

- .1 Erect temporary site enclosures minimum 1500mm high and such that at maximum a 100mm diameter object cannot pass through the fencing. Maintain fence in good repair.
- .2 Provide one lockable truck entrance gate and at least one pedestrian door as directed and conforming to applicable traffic restrictions on adjacent streets. Equip gates with locks and keys.
- .3 Maintain pedestrian walkways, complete with signs and electrical lighting as required by law.
- .4 Provide barriers around trees and plants designated to remain. Protect from damage by equipment and construction procedures.

1.6 Guard Rails and Barricades

- .1 Provide as required by governing authorities including Department of Labour, Workplace Health and Safety regulations as a minimum.

1.7 Weather Enclosures

- .1 Provide weather tight closures to unfinished door and window openings, tops of shafts and other openings in floors and roofs.
- .2 Close off floor areas where walls are not finished; seal off other openings; enclose building interior Work for temporary heat.
- .3 Design enclosures to withstand wind pressure and snow loading.

1.8 Access to Site

- .1 Provide and maintain access roads, sidewalk crossings, ramps and construction runways as may be required for access to Work.

1.9 Public Traffic Flow

- .1 Provide and maintain competent signal flag operators, traffic signals, barricades and flares, lights, or lanterns as required to perform Work and protect the public.

1.10 Fire Routes

- .1 Maintain access to property including overhead clearances for use by emergency response vehicles.

1.11 Protection for Off-Site and Public Property

- .1 Protect surrounding private and public property from damage during performance of Work.
- .2 Be responsible for damage incurred.

1.12 Protection of Building Finishes

- .1 Provide protection for finished and partially finished building finishes and equipment during performance of Work.
- .2 Provide necessary screens, covers, and hoardings.
- .3 Be responsible for damage incurred due to lack of or improper protection.

PART 2 PRODUCTS

2.1 Not Used

PART 3 EXECUTION

3.1 Not Used

END OF SECTION

PART 1 GENERAL

1.1 Fires

- .1 Fires and burning of rubbish on site not permitted.

1.2 Disposal of Wastes

- .1 Do not bury rubbish and waste materials on site unless approved by Contract Administrator.
- .2 Do not dispose of waste or volatile materials, such as mineral spirits, oil or paint thinner into waterways, storm or sanitary sewers.

1.3 Drainage

- .1 Provide temporary drainage and pumping as necessary to keep excavations and site free from water.
- .2 Do not pump water containing suspended materials into waterways, sewer or drainage systems.
- .3 Control disposal or runoff of water containing suspended materials or other harmful substances in accordance with local authority requirements.

1.4 Site Clearing and Plant Protection

- .1 Protect trees and plants on site and adjacent properties where indicated.
- .2 Wrap in burlap, trees and shrubs adjacent to construction Work, storage areas and trucking lanes, and encase with protective wood framework from grade level to height of 2 m.
- .3 Protect roots of designated trees to dripline during excavation and site grading to prevent disturbance or damage. Avoid unnecessary traffic, dumping and storage of materials over root zones.
- .4 Minimize stripping of topsoil and vegetation.
- .5 Restrict tree removal to areas indicated or designated by Contract Administrator.

1.5 Pollution Control

- .1 Maintain temporary erosion and pollution control features installed under this Contract.
- .2 Control emissions from equipment and plant to local authorities emission requirements.
- .3 Prevent sandblasting and other extraneous materials from contaminating air beyond application area, by providing temporary enclosures.
- .4 Cover or wet down dry materials and rubbish to prevent blowing dust and debris.

PART 2 PRODUCTS

2.1 Not Used

.1 Not Used.

PART 3 EXECUTION

3.1 Not Used

.1 Not Used.

END OF SECTION

PART 1 GENERAL

1.1 Section Includes

- .1 Product quality, availability, storage, handling, protection, and transportation.
- .2 Manufacturer's instructions.
- .3 Quality of Work, coordination and fastenings.
- .4 Existing facilities.

1.2 Related Sections

- .1 Section 01420 - References.
- .2 Section 01450 - Quality Control.

1.3 Reference Standards

- .1 Within text of specifications, reference may be made to reference standards contained in Section 01420 - References.
- .2 Conform to these standards, in whole or in part as specifically requested in specifications.
- .3 If there is question as to whether any product or system is in conformance with applicable standards, Contract Administrator reserves right to have such products or systems tested to prove or disprove conformance.
- .4 The cost for such testing will be borne by the City in event of conformance with Contract Documents or by Contractor in event of non-conformance.
- .5 Conform to latest date of issue of referenced standards in effect on date of submission of Bids, except where specific date or issue is specifically noted.

1.4 Quality

- .1 Products, materials, equipment and articles (referred to as products throughout specifications) incorporated in Work shall be new, not damaged or defective, and of best quality (compatible with specifications) for purpose intended. If requested, furnish evidence as to type, source and quality of Products provided.
- .2 Defective products, whenever identified prior to completion of Work, will be rejected, regardless of previous inspections. Inspection does not relieve responsibility, but is precaution against oversight or error. Remove and replace defective products at own expense and be responsible for delays and expenses caused by rejection.
- .3 Should any dispute arise as to quality or fitness of products, decision rests strictly with Contract Administrator based upon requirements of Contract Documents.

- .4 Unless otherwise indicated in specifications, maintain uniformity of manufacture for any particular or like item throughout building.
- .5 Permanent labels, trademarks and nameplates on products are not acceptable in prominent locations, except where required for operating instructions, or when located in mechanical or electrical rooms.

1.5 Availability

- .1 Immediately upon Contract Award, review product delivery requirements and anticipate foreseeable supply delays for any items. If delays in supply of products are foreseeable, notify Contract Administrator of such, in order that substitutions or other remedial action may be authorized in ample time to prevent delay in performance of Work.
- .2 In event of failure to notify Contract Administrator at commencement of Work and should it subsequently appear that Work may be delayed for such reason, Contract Administrator reserves right to substitute more readily available products of similar character, at no increase in Contract Price or Contract Time.

1.6 Storage, Handling and Protection

- .1 Handle and store products in manner to prevent damage, adulteration, deterioration and soiling and in accordance with manufacturer's instructions when applicable.
- .2 Store packaged or bundled products in original and undamaged condition with manufacturer's seal and labels intact. Do not remove from packaging or bundling until required in Work.
- .3 Store products subject to damage from weather in weatherproof enclosures.
- .4 Store cementitious products clear of earth or concrete floors, and away from walls.
- .5 Keep sand, when used for grout or mortar materials, clean and dry. Store sand on wooden platforms and cover with waterproof tarpaulins during inclement weather.
- .6 Store sheet materials and lumber on flat, solid supports and keep clear of ground. Slope to shed moisture.
- .7 Store and mix paints in heated and ventilated room. Remove oily rags and other combustible debris from site daily. Take every precaution necessary to prevent spontaneous combustion.
- .8 Remove and replace damaged products at own expense and to satisfaction of Contract Administrator.
- .9 Touch-up damaged factory finished surfaces to Contract Administrator's satisfaction. Use touch-up materials to match original. Do not paint over name plates.

1.7 Transportation

- .1 Pay costs of transportation of products required in performance of Work.
- .2 Contractor to pay transportation costs on recycled products supplied by the City. Unload, handle and store such products.

1.8 Manufacturer's Instructions

- .1 Unless otherwise indicated in specifications, install or erect products in accordance with manufacturer's instructions. Do not rely on labels or enclosures provided with products. Obtain written instructions directly from manufacturers.
- .2 Notify Contract Administrator in writing, of conflicts between specifications and manufacturer's instructions, so that Contract Administrator may establish course of action.
- .3 Improper installation or erection of products, due to failure in complying with these requirements, authorizes Contract Administrator to require removal and re-installation at no increase in Contract Price or Contract Time.

1.9 Quality of Work

- .1 Ensure Quality of Work is of highest standard, executed by workers experienced and skilled in respective duties for which they are employed. Immediately notify Contract Administrator if required Work is such as to make it impractical to produce required results.
- .2 Do not employ anyone unskilled in his or her required duties. Contract Administrator reserves right to require dismissal from site, workers deemed incompetent or careless.
- .3 Decisions as to standard or fitness of Quality of Work in cases of dispute rest solely with Contract Administrator, whose decision is final.

1.10 Co-Ordination

- .1 Ensure cooperation of workers in laying out Work. Maintain efficient and continuous supervision.
- .2 Be responsible for coordination and placement of openings, sleeves and accessories.

1.11 Concealment

- .1 In finished areas, conceal pipes, ducts and wiring in floors, walls and ceilings, except where indicated otherwise.
- .2 Before installation, inform Contract Administrator if there is interference. Install as directed by Contract Administrator.

1.12 Remedial Work

- .1 Perform remedial Work required to repair or replace parts or portions of Work identified as defective or unacceptable. Coordinate adjacent affected Work as required.
- .2 Perform remedial Work by specialists familiar with materials affected. Perform in a manner to neither damage nor put at risk any portion of Work.

1.13 Location of Fixtures

- .1 Consider location of fixtures, outlets, and mechanical and electrical items indicated as approximate.
- .2 Inform Contract Administrator of conflicting installation. Install as directed.

1.14 Fastenings

- .1 Provide metal fastenings and accessories in same texture, colour and finish as adjacent materials, unless indicated otherwise.
- .2 Prevent electrolytic action between dissimilar metals and materials.
- .3 Use non-corrosive hot dip galvanized steel fasteners and anchors for securing exterior Work, unless stainless steel or other material is specifically requested in affected specification Section.
- .4 Space anchors within individual load limit or shear capacity and ensure they provide positive permanent anchorage. Wood, or any other organic material plugs are not acceptable.
- .5 Keep exposed fastenings to a minimum, space evenly and install neatly.
- .6 Fastenings which cause spalling or cracking of material to which anchorage is made are not acceptable.

1.15 Fastenings - Equipment

- .1 Use fastenings of standard commercial sizes and patterns with material and finish suitable for service.
- .2 Use heavy hexagon heads, semi-finished unless otherwise specified. Use No. 304 stainless steel for exterior areas.
- .3 Bolts may not project more than one diameter beyond nuts.
- .4 Use plain type washers on equipment, sheet metal and soft gasket lock type washers where vibrations occur. Use resilient washers with stainless steel.

1.16 Protection of Work in Progress

- .1 Prevent overloading of any part of building. Do not cut, drill or sleeve any load bearing structural member, unless specifically indicated without written approval of Contract Administrator.

1.17 Existing Utilities

- .1 When breaking into or connecting to existing services or utilities, execute Work at times directed by local governing authorities, with minimum of disturbance to Work, and pedestrian and vehicular traffic.
- .2 Protect, relocate or maintain existing active services. When services are encountered, cap off in manner approved by authority having jurisdiction. Stake and record location of capped service.

PART 2 PRODUCTS

2.1 Not Used

- .1 Not Used.

PART 3 EXECUTION

3.1 Not Used

- .1 Not Used.

END OF SECTION

PART 1 GENERAL

1.1 Related Sections

- .1 Section 01330 - Submittal procedures.

1.2 References

- .1 Canada Labour Code, Part 2, Canada Occupational Safety and Health Regulations.
- .2 Province of Manitoba
 - .1 Workplace Safety and Health Act, R.S.M. 1987.

1.3 Submittals

- .1 Make submittals in accordance with Section 01330 - Submittal Procedures.
- .2 City Safe Work Plan as per Supplemental Conditions Clause D7.
- .3 Submit copies of reports or directions issued by Federal, Provincial and Territorial health and safety inspectors.
- .4 Submit copies of incident and accident reports.
- .5 Submit Material Safety Data Sheets (MSDS) to Contract Administrator.
- .6 Contract Administrator will review Contractor's site-specific Safe Work Plan and provide comments to Contractor within 7 days after receipt of plan. Revise plan as appropriate and resubmit plan to Contract Administrator within 7 days after receipt of comments from Contract Administrator.
- .7 Contract Administrator's review of Contractor's final Safe Work Plan should not be construed as approval and does not reduce the Contractor's overall responsibility for Construction Health and Safety.
- .8 Medical Surveillance: Where prescribed by legislation, regulation or safety program, submit certification of medical surveillance for site personnel prior to commencement of Work, and submit additional certifications for any new site personnel to Contract Administrator.
- .9 Provide a Fall Protection Plan for any type of structure, if required by the authority having jurisdiction, prior to construction of facility.
- .10 On-site Contingency and Emergency Response Plan: Address standard operating procedures to be implemented during emergency situations.
 - .1 Promptly report all accidents and potential liability claims to the Contract Administrator.

1.4 Filing of Notice

- .1 File Notice of Project with Provincial authorities prior to commencement of Work unless otherwise dictated by Law.

1.5 Safety Assessment

- .1 Perform site specific safety hazard assessment related to project.

1.6 Meetings

- .1 If requested by Contract Administrator, schedule and administer Health and Safety meeting with Contract Administrator prior to commencement of Work.

1.7 General Requirements

- .1 Develop written site-specific Safe Work Plan based on hazard assessment prior to commencing any site Work and continue to implement, maintain, and enforce plan until final demobilization from site. Safe Work Plan must address project specifications.
- .2 Contract Administrator may respond in writing, where deficiencies or concerns are noted and may request re-submission with correction of deficiencies or concerns.

1.8 Responsibility

- .1 Be responsible for health and safety of persons on site, safety of property on site and for protection of persons adjacent to site and environment to extent that they may be affected by conduct of Work.
- .2 Comply with and enforce compliance by employees with safety requirements of Contract Documents, applicable federal, provincial, territorial and local statutes, regulations, and ordinances, and with site-specific Safe Work Plan.

1.9 Compliance Requirements

- .1 Comply with Workplace Safety and Health Act, Workplace Safety Regulation, Manitoba Reg.
- .2 Provide Fall Protection Anchoring device(s) as per Dept. of Labour requirement, Manitoba Regulation 189/85 section 15(1) under the Workplace Safety and Health Act.
- .3 For equipment that develop high levels of sound transmission, provide all necessary design and signage to ensure a safe workplace as defined by Manitoba Labour Workplace Safety and Health Division.
- .4 Comply with Occupational Health and Safety Regulations, 1996.
- .5 Comply with Canada Labour Code, Canada Occupational Safety and Health Regulations.

1.10 Unforeseen Hazards

- .1 Should any unforeseen or peculiar safety-related factor, hazard, or condition become evident during performance of Work, and follow procedures in place for Employee's Right to Refuse Work in accordance with Acts and Regulations of Province having jurisdiction. Advise Contract Administrator verbally and in writing.

1.11 Posting of Documents

- .1 Ensure applicable items, articles, notices and orders are posted in conspicuous location on site in accordance with Acts and Regulations of Province having jurisdiction, and in consultation with Contract Administrator.

1.12 Correction of Non-Compliance

- .1 Immediately address health and safety non-compliance issues identified by authority having jurisdiction or by Contract Administrator.
- .2 Provide Contract Administrator with written report of action taken to correct non-compliance of health and safety issues identified.
- .3 Contract Administrator may stop Work if non-compliance of health and safety regulations is not corrected.

1.13 Blasting

- .1 Blasting or other use of explosives is not permitted without prior receipt of written instruction by Contract Administrator.

1.14 Powder Actuated Devices

- .1 Use powder actuated devices only after receipt of written permission from Contract Administrator.

1.15 Work Stoppage

- .1 Give precedence to safety and health of public and site personnel and protection of environment over cost and schedule considerations for Work.

PART 2 PRODUCTS

2.1 Not Used

- .1 Not used.

PART 3 EXECUTION

3.1 Not Used

- .1 Not used.

END OF SECTION

PART 1 GENERAL

1.1 Section Includes

- .1 Field engineering survey services to measure and stake site.
- .2 Survey services to establish inverts for Work.
- .3 Recording of subsurface conditions found.

1.2 References

- .1 City's identification of existing survey control points and property limits.

1.3 Qualifications of Surveyor

- .1 Qualified registered land surveyor, licensed to practise in Place of Work, acceptable to Contract Administrator.

1.4 Survey Reference Points

- .1 Existing base horizontal and vertical control points are designated on drawings.
- .2 Locate, confirm and protect control points prior to starting site Work. Preserve permanent reference points during construction.
- .3 Make no changes or relocations without prior written notice to Contract Administrator.
- .4 Report to Contract Administrator when reference point is lost or destroyed, or requires relocation because of necessary changes in grades or locations.
- .5 Require surveyor to replace control points in accordance with original survey control.

1.5 Survey Requirements

- .1 Establish two permanent bench marks on site, referenced to established bench marks by survey control points. Record locations, with horizontal and vertical data in Project Record Documents.
- .2 Establish lines and levels, locate and lay out, by instrumentation.
- .3 Stake for grading, fill placement.
- .4 Stake slopes.
- .5 Establish pipe invert elevations.
- .6 Stake batter boards for foundations.
- .7 Establish foundation column locations, major grid radius points and floor elevations.

- .8 Establish lines and levels for mechanical and electrical Work.

1.6 Existing Services

- .1 Before commencing Work, establish location and extent of service lines in area of Work and notify Contract Administrator of findings.
- .2 Remove abandoned service lines within 2 metres of structures. Cap or otherwise seal lines at cut-off points as directed by Contract Administrator.

1.7 Location of Equipment and Fixtures

- .1 Location of equipment, fixtures and outlets indicated or specified are to be considered as approximate.
- .2 Locate equipment, fixtures and distribution systems to provide minimum interference and maximum usable space and in accordance with manufacturer's recommendations for safety, access and maintenance.
- .3 Inform Contract Administrator of impending installation and obtain approval for actual location.
- .4 Submit field drawings to indicate relative position of various services and equipment when required by Contract Administrator.

1.8 Records

- .1 Maintain a complete, accurate log of control and survey Work as it progresses.
- .2 Record locations of maintained, re-routed and abandoned service lines.

1.9 Submittals

- .1 Submit name and address of Surveyor to Contract Administrator.
- .2 On request of Contract Administrator, submit documentation to verify accuracy of field engineering Work.
- .3 Submit certificate signed by surveyor certifying those elevations and locations of completed Work that conform and do not conform with Contract Documents.
- .4 Provide a surveyor's sealed and stamped drawing indicating building location certificate at project completion.

1.10 Subsurface Conditions

- .1 Promptly notify Contract Administrator in writing if subsurface conditions at Place of Work differ materially from those indicated in Contract Documents, or a reasonable assumption of probable conditions based thereon.
- .2 After prompt investigation, should Contract Administrator determine that conditions do differ materially, instructions will be issued for Changes in Work by Change Order, and Change Directive.

PART 2 PRODUCTS

2.1 Not Used

.1 Not Used.

PART 3 EXECUTION

3.1 Not Used

.1 Not Used.

END OF SECTION

PART 1 GENERAL

1.1 Section Includes

- .1 Progressive cleaning.
- .2 Final cleaning.

1.2 Related Section

- .1 Section 01770 - Closeout Procedures.

1.3 Project Cleanliness

- .1 Maintain Work in tidy condition, free from accumulation of waste products and debris, other than that caused by the City or other Contractors.
- .2 Remove waste materials from site at regularly scheduled times or dispose of as directed by Contract Administrator. Do not burn waste materials on site.
- .3 Clear snow and ice from access to building, bank/pile snow in designated areas only.
- .4 Make arrangements with and obtain permits from authorities having jurisdiction for disposal of waste and debris.
- .5 Provide on-site dump containers for collection of waste materials and debris.
- .6 Provide and use clearly marked separate bins for recycling.
- .7 Remove waste material and debris from site and deposit in waste container at end of each working day.
- .8 Clean interior areas prior to start of finish Work, and maintain areas free of dust and other contaminants during finishing operations.
- .9 Store volatile waste in covered metal containers, and remove from premises at end of each working day.
- .10 Provide adequate ventilation during use of volatile or noxious substances. Use of building ventilation systems is not permitted for this purpose.
- .11 Use only cleaning materials recommended by manufacturer of surface to be cleaned, and as recommended by cleaning material manufacturer.
- .12 Schedule cleaning operations so that resulting dust, debris and other contaminants will not fall on wet, newly painted surfaces nor contaminate building systems.

1.4 Final Cleaning

- .1 When Work is Substantially Performed, remove surplus products, tools, construction machinery and equipment not required for performance of remaining Work.
- .2 Remove waste products and debris other than that caused by others, and leave Work clean and suitable for occupancy.
- .3 Prior to final review, remove surplus products, tools, construction machinery and equipment.
- .4 Remove waste products and debris other than that caused by the City or other Contractors.
- .5 Remove waste materials from site at regularly scheduled times or dispose of as directed by Contract Administrator. Do not burn waste materials on site.
- .6 Make arrangements with and obtain permits from authorities having jurisdiction for disposal of waste and debris.
- .7 Clean and polish glass, mirrors, hardware, wall tile, stainless steel, chrome, porcelain enamel, baked enamel, plastic laminate, and mechanical and electrical fixtures. Replace broken, scratched or disfigured glass to Contract Administrator's approval.
- .8 Remove stains, spots, marks and dirt from decorative Work, electrical and mechanical fixtures, furniture fittings, walls, and floors.
- .9 Clean lighting reflectors, lenses, and other lighting surfaces.
- .10 Vacuum clean and dust building interiors, behind grilles, louvres and screens.
- .11 Wax, seal, shampoo or prepare floor finishes, as recommended by manufacturer.
- .12 Inspect finishes, fittings and equipment and ensure specified workmanship and operation.
- .13 Broom clean and wash exterior walks, steps and surfaces; rake clean other surfaces of grounds.
- .14 Remove dirt and other disfiguration from exterior surfaces.
- .15 Clean and sweep roofs, gutters, areaways, and sunken wells.
- .16 Sweep and wash clean paved areas.
- .17 Clean equipment and fixtures to a sanitary condition; clean or replace filters of mechanical equipment.
- .18 Clean roofs, downspouts, and drainage systems.
- .19 Remove debris and surplus materials from crawl areas and other accessible concealed spaces.

.20 Remove snow and ice from access to building.

PART 2 PRODUCTS

2.1 Not Used

.1 Not Used.

PART 3 EXECUTION

3.1 Not Used

.1 Not Used.

END OF SECTION

PART 1 GENERAL

1.1 Section Includes

- .1 Administrative procedures preceding preliminary and final inspections of Work.

1.2 Related Sections

- .1 Section 01780 - Closeout Submittals.

1.3 Inspection and Declaration

- .1 Contractor's Inspection: Contractor and all Sub-trades shall conduct an inspection of Work, identify deficiencies and defects, and repair as required to conform to Contract Documents.
 - .1 Notify Contract Administrator in writing of satisfactory completion of Contractor's Inspection and that corrections have been made.
 - .2 Request Contract Administrator's Inspection.
- .2 Contract Administrator's Inspection: Contract Administrator and Contractor will perform inspection of Work to identify obvious defects or deficiencies. Contractor shall correct Work accordingly.
- .3 Completion: submit written certificate that following have been performed:
 - .1 Work has been completed and inspected for compliance with Contract Documents.
 - .2 Defects have been corrected and deficiencies have been completed.
 - .3 Equipment and systems have been tested, adjusted and balanced and are fully operational.
 - .4 Certificates required by Fire Commissioner and Utility companies have been submitted.
 - .5 Operation of systems have been demonstrated to City's personnel.
 - .6 Work is complete and ready for Final Inspection.
- .4 Final Inspection: when items noted above are completed, request final inspection of Work by Contract Administrator, and Contractor. If Work is deemed incomplete by Contract Administrator, complete outstanding items and request re-inspection.
- .5 Declaration of Substantial Performance: when Contract Administrator considers deficiencies and defects have been corrected and it appears requirements of Contract have been substantially performed, make application for certificate of Substantial Performance. Refer to City of Winnipeg Certificate of Substantial Performance of Work.
- .6 Commencement of Lien and Warranty Periods: date of Owner's acceptance of submitted declaration of Total Performance shall be date for commencement for

warranty period and commencement of lien period unless required otherwise by lien statute of Place of Work.

- .7 Final Payment: When Contract Administrator considers final deficiencies and defects have been corrected and it appears requirements of Contract have been totally performed, make application for final payment. If Work is deemed incomplete by Contract Administrator, complete outstanding items and request re-inspection.
- .8 Payment of Holdback: After issuance of certificate of Substantial Performance of Work, submit an application for payment of holdback amount.

PART 2 PRODUCTS

2.1 Not Used

- .1 Not Used.

PART 3 EXECUTION

3.1 Not Used

- .1 Not Used.

END OF SECTION

PART 1 GENERAL

1.1 Section Includes

- .1 As-built drawings, samples, and specifications.
- .2 Equipment and systems.
- .3 Product data, materials and finishes, and related information.
- .4 Operation and maintenance data.
- .5 Spare parts, special tools and maintenance materials.
- .6 Warranties and bonds.
- .7 Final site survey certificate.

1.2 Related Sections

- .1 Section 01330 - Submittal Procedures.
- .2 Section 01450 - Quality Control.
- .3 Section 01720 - Preparation.
- .4 Section 01770 - Closeout Procedures.

1.3 Submission

- .1 Prepare instructions and data by personnel experienced in maintenance and operation of described products.
- .2 Copy will be returned after final inspection, with Contract Administrator's comments.
- .3 Revise content of documents as required prior to final submittal.
- .4 Two weeks prior to Substantial Performance of the Work, submit to the Contract Administrator, four final copies of operating and maintenance manuals in English.
- .5 Ensure spare parts, maintenance materials and special tools provided are new, undamaged or defective, and of same quality and manufacture as products provided in Work.
- .6 If requested, furnish evidence as to type, source and quality of products provided.
- .7 Defective products will be rejected, regardless of previous inspections. Replace products at own expense.
- .8 Pay costs of transportation.

1.4 Format

- .1 Organize data in the form of an instructional manual.
- .2 Binders: vinyl, hard covered, 3 'D' ring, loose leaf with spine.
- .3 When multiple binders are used, correlate data into related consistent groupings. Identify contents of each binder on spine.
- .4 Cover: Identify each binder with type or printed title 'Project Record Documents'; list title of project and identify subject matter of contents.
- .5 Arrange content by systems under Section numbers and sequence of Table of Contents.
- .6 Provide tabbed fly leaf for each separate product and system, with typed description of product and major component parts of equipment.
- .7 Text: Manufacturer's printed data, or typewritten data.
- .8 Drawings: provide with reinforced punched binder tab. Bind in with text; fold larger drawings to size of text pages.

1.5 Contents - Each Volume

- .1 Table of Contents: provide title of project;
 - .1 date of submission; names,
 - .2 addresses, and telephone numbers of Contract Administrator and with name of responsible parties;
 - .3 schedule of products and systems, indexed to content of volume.
- .2 For each product or system:
 - .1 list full names, addresses and telephone numbers of applicable sub-trades and suppliers, including local source of supplies and replacement parts.
- .3 Product Data: mark each sheet to clearly identify specific products and component parts, and data applicable to installation; delete inapplicable information.
- .4 Drawings: supplement product data to illustrate relations of component parts of equipment and systems, to show control and flow diagrams.
- .5 Typewritten Text: as required to supplement product data. Provide logical sequence of instructions for each procedure, incorporating manufacturer's instructions specified in Section 01450 - Quality Control.

1.6 As-builts and Samples

- .1 In addition to requirements in General Conditions, maintain at the site for Contract Administrator one record copy of:

- .1 Contract Drawings (As built).
 - .2 Specifications.
 - .3 Addenda.
 - .4 Change Orders and other modifications to the Contract.
 - .5 Reviewed shop drawings, product data, and samples.
 - .6 Field test records.
 - .7 Inspection certificates.
 - .8 Manufacturer's certificates.
- .2 Store record documents and samples in field office apart from documents used for construction. Provide files, racks, and secure storage.
 - .3 Label record documents and file in accordance with Section number listings in List of Contents of this Project Manual. Label each document "PROJECT RECORD" in neat, large, printed letters.
 - .4 Maintain record documents in clean, dry and legible condition. Do not use record documents for construction purposes.
 - .5 Keep record documents and samples available for inspection by Contract Administrator.

1.7 Recording Actual Site Conditions

- .1 Record information on set of black line opaque drawings, and in copy of Project Manual, provided by Contract Administrator.
- .2 Provide felt tip marking pens, maintaining separate colours for each major system, for recording information.
- .3 Record information concurrently with construction progress. Do not conceal Work until required information is recorded.
- .4 Contract Drawings and shop drawings: legibly mark each item to record actual construction, including:
 - .1 Measured depths of elements of foundation in relation to finish first floor datum.
 - .2 Measured horizontal and vertical locations of underground utilities and appurtenances, referenced to permanent surface improvements.
 - .3 Measured locations of internal utilities and appurtenances, referenced to visible and accessible features of construction.
 - .4 Field changes of dimension and detail.
 - .5 Changes made by change orders.
 - .6 Details not on original Contract Drawings.
 - .7 References to related shop drawings and modifications.

- .5 Specifications: legibly mark each item to record actual construction, including:
 - .1 Manufacturer, trade name, and catalogue number of each product actually installed, particularly optional items and substitute items.
 - .2 Changes made by Addenda and change orders.
- .6 Other Documents: maintain manufacturer's certifications, inspection certifications, field test records, required by individual specifications sections.

1.8 Final Survey

- .1 Contractor is to provide Building Location Certificate at project completion.

1.9 Equipment and Systems

- .1 Each Item of Equipment and Each System: include description of unit or system, and component parts. Give function, normal operation characteristics, and limiting conditions. Include performance curves, with engineering data and tests, and complete nomenclature and commercial number of replaceable parts.
- .2 Panel board circuit directories: provide electrical service characteristics, controls, and communications.
- .3 Include installed colour coded wiring diagrams.
- .4 Operating Procedures: include start-up, break-in, and routine normal operating instructions and sequences. Include regulation, control, stopping, shut-down, and emergency instructions. Include summer, winter, and any special operating instructions.
- .5 Maintenance Requirements: include routine procedures and guide for troubleshooting; disassembly, repair, and reassembly instructions; and alignment, adjusting, balancing, and checking instructions.
- .6 Provide servicing and lubrication schedule, and list of lubricants required.
- .7 Include manufacturer's printed operation and maintenance instructions.
- .8 Include sequence of operation by controls manufacturer.
- .9 Provide original manufacturer's parts list, illustrations, assembly drawings, and diagrams required for maintenance.
- .10 Provide installed control diagrams by controls manufacturer.
- .11 Provide Contractor's coordination drawings, with installed colour coded piping diagrams.
- .12 Provide charts of valve tag numbers, with location and function of each valve, keyed to flow and control diagrams.
- .13 Provide list of original manufacturer's spare parts, current prices, and recommended quantities to be maintained in storage.

- .14 Include test and balancing reports as specified in Section 01450 - Quality Control.
- .15 Additional requirements: As specified in individual specification sections.

1.10 Materials and Finishes

- .1 Building Products, Applied Materials, and Finishes: include product data, with catalogue number, size, composition, and colour and texture designations. Provide information for re-ordering custom manufactured products.
- .2 Instructions for cleaning agents and methods, precautions against detrimental agents and methods, and recommended schedule for cleaning and maintenance.
- .3 Moisture-protection and Weather-exposed Products: include manufacturer's recommendations for cleaning agents and methods, precautions against detrimental agents and methods, and recommended schedule for cleaning and maintenance.
- .4 Additional Requirements: as specified in individual specifications sections.

1.11 Spare Parts

- .1 Provide spare parts, in quantities specified in individual specification sections.
- .2 Provide items of same manufacture and quality as items in Work.
- .3 Deliver to site; place and store.
- .4 Receive and catalogue all items. Submit inventory listing to Contract Administrator. Include approved listings in Maintenance Manual.
- .5 Obtain receipt for delivered products and submit prior to final payment.

1.12 Maintenance Materials

- .1 Provide maintenance and extra materials, in quantities specified in individual specification sections.
- .2 Provide items of same manufacture and quality as items in Work.
- .3 Deliver to site; place and store in locations as directed by Construction Administrator.
- .4 Receive and catalogue all items. Submit inventory listing to Contract Administrator. Include approved listings in Maintenance Manual.
- .5 Obtain receipt for delivered products and submit prior to final payment.

1.13 Special Tools

- .1 Provide special tools, in quantities specified in individual specification section.

- .2 Provide items with tags identifying their associated function and equipment.
- .3 Deliver to site; place and store.
- .4 Receive and catalogue all items. Submit inventory listing to Contract Administrator. Include approved listings in Maintenance Manual.

1.14 Storage, Handling and Protection

- .1 Store spare parts, maintenance materials, and special tools in manner to prevent damage or deterioration.
- .2 Store in original and undamaged condition with manufacturer's seal and labels intact.
- .3 Store components subject to damage from weather in weatherproof enclosures.
- .4 Store paints and freezable materials in a heated and ventilated room.
- .5 Remove and replace damaged products at own expense and to satisfaction of Contract Administrator.

1.15 Warranties and Bonds

- .1 Separate each warranty or bond with index tab sheets keyed to Table of Contents listing.
- .2 List subcontractor, supplier, and manufacturer, with name, address, and telephone number of responsible principal.
- .3 Obtain warranties and bonds, executed in duplicate by subcontractors, suppliers, and manufacturers, within ten days after completion of the applicable item of Work.
- .4 Except for items put into use with City's permission, leave date of beginning of time of warranty until the Date of Total Performance is determined.
- .5 Verify that documents are in proper form, contain full information, and are notarized.
- .6 Co-execute submittals when required.
- .7 Retain warranties and bonds until time specified for submittal.

PART 2 PRODUCTS

2.1 Not Used

- .1 Not Used.

PART 3 EXECUTION

3.1 Not Used

.1 Not Used.

END OF SECTION

PART 1 GENERAL

1.1 Section Includes

- .1 Includes general requirements for commissioning facilities and facility systems.

1.2 Related Sections

- .1 Section 01450 - Quality Control.

1.3 Quality Assurance

- .1 Co-operate with testing organization services under provisions specified in Section 01450 - Quality Control.
- .2 Testing organization: to Contract directly with the City.
- .3 Comply with applicable procedures and standards of the certification sponsoring association.

1.4 References

- .1 Associated Air Balance Council (AABC): National Standards For Field Measurements and Instrumentation, Total Systems Balance, Air Distribution-Hydronics Systems.

1.5 Submittals

- .1 Prior to start of Work, submit name of Contractor personnel proposed to perform services. Designate who has managerial responsibilities for coordination of entire testing, adjusting and balancing with Testing organization.

1.6 Procedures - General

- .1 Coordinate Work of Trades and sub-trades with Testing organization.
- .2 Cooperate with Testing organization requests for information.

1.7 Contractor Responsibilities

- .1 Prepare each system for testing and balancing.
- .2 Cooperate with testing organization and provide access to equipment and systems.
- .3 Provide personnel and operate systems at designated times, and under conditions required for proper testing, adjusting, and balancing, as required by the testing organization.
- .4 Notify testing organization 7 days prior to time project will be ready for testing, adjusting, and balancing.

1.8 Schedule of Systems Requiring Testing, Adjusting, and Balancing Services

- .1 Division 15 - All HVAC equipment systems.
- .2 Section 15400 – Plumbing
- .3 Division 16 – Electrical power systems
- .4 Division 16 – All electrical equipment related to the HVAC systems
- .5 Section 16500 – Scheduled lighting controls
- .6 Section 16723, 16519, 16535 – Life safety systems (fire alarm, egress pressurization, fire protection).
- .7 Section 16741– Data and communication

PART 2 PRODUCTS

2.1 Not Used

- .1 Not Used.

PART 3 EXECUTION

3.1 Functional Testing

- .1 Review the “Design Intent / Basis of Design” documentation.
- .2 Review and implement the commissioning plan.

END OF SECTION

PART 1 GENERAL

- .1 This section specifies requirements for demolishing, salvaging and removing wholly or in part, various items designated to be removed or partially removed and for backfilling resulting trenches, holes and pits.

1.1 Related Sections

- .1 Section 02222- Excavation

1.2 Protection

- .1 Protect existing objects designated to remain and materials designated for salvage. In event of damage immediately replace or make repairs subject to the Contract Administrator's approval of and at no additional cost to the project.

PART 2 PRODUCTS

2.1 Not Used

PART 3 EXECUTION

3.1 Preparation

- .1 Inspect site and verify with Contract Administrator objects designated for removal and objects to be preserved.
- .2 Locate and protect utility lines. Preserve in operating condition active utilities traversing site.

3.2 Removal

- .1 Remove objects indicated on the drawing (bleachers and chain link back stop).
- .2 Do not disturb adjacent items designated to remain in place.
- .3 In removal of pavements, curbs and gutters:
 - .1 Square up adjacent surfaces to remain in place by saw cutting or other approved method.
 - .2 Protect adjacent joints and load transfer devices.
 - .3 Protect underlying granular materials.
 - .4 When removing pipes under existing or future pavement area excavate at least 300 mm below pipe invert.
 - .5 Provide for suppression of dust generated by removal process.

3.3 Disposal Of Material

- .1 Dispose of materials not designated for salvage or re-use in Work, off-site.

3.4 Backfill

- .1 In paved area, backfill with granular material and shape excavation to elevations shown on the drawing in accordance with Section 02223.
- .2 In areas not to be paved, backfill and shape excavation to elevation shown on drawings with common backfill approved by Contract Administrator and in accordance with Section 02223.

3.5 Restoration

- .1 Upon completion of Work, remove debris, trim surfaces and leave Work site clean.
- .2 Reinstate areas and existing Works outside areas of demolition to conditions that existed prior to commencement of Work.

END OF SECTION

PART 1 GENERAL

1.1 Section Includes

- .1 Excavation for paving and landscaping.

1.2 Related Sections

- .1 Section 02223 – SiteWork Demolition and Removal.
- .2 Section 02225- Excavation and Backfilling – Buildings.
- .3 Section 02911 - Topsoil and Finish Grading.

1.3 Field Measurements

- .1 Verify that survey benchmark and intended elevations for the Work as indicated.

PART 2 PRODUCTS

2.1 Not Used

PART 3 EXECUTION

3.1 Protection

- .1 Size, depth and location of existing utilities as indicated for guidance only: completeness and accuracy are not guaranteed.
- .2 Protect existing buildings, trees and other plants, lawns, fencing, service poles, wires, and paving located within right-of-way or adjoining properties from damage while Work is in progress and repair damage resulting from Work.
- .3 Maintain and protect from damage, water, sewer, gas, electric, telephone and other utilities encountered.
- .4 Protect excavations by methods required to prevent cave-in or loose soil from falling into excavation.
- .5 Protect bottom of excavations and soil adjacent to and beneath foundation, from freezing.

3.2 Preparation

- .1 Identify required lines, levels, contours and datum.
- .2 Identify known underground, above ground, and aerial utilities. Stake and flag locations.

- .3 Protect above and below grade utilities which are to remain.
- .4 Protect plant life, lawns and other features remaining as a portion of final landscaping.
- .5 Protect bench marks, fences, sidewalks, paving, and curbs from excavation equipment and vehicular traffic.

3.3 Excavation

- .1 Underpin adjacent structures which may be damaged by excavation Work, including utilities and pipe chases.
- .2 Excavate subsoil required to accommodate building foundations, slabs-on-grade, utilities, paving and construction operations.
- .3 Coordinate special requirements for piling.
- .4 Machine slope banks to angle of repose or less, until shored.
- .5 Excavation cut not to interfere with normal 45 degree bearing splay of foundation.
- .6 Grade top perimeter of excavation to prevent surface water from draining into excavation.
- .7 Hand trim excavation. Remove loose matter.
- .8 Remove lumped subsoil, boulders, and rock up to 0.3 cu. yd. measured by volume.
- .9 Notify Contract Administrator of unexpected subsurface conditions and discontinue affected Work in area until notified to resume Work.
- .10 Correct unauthorized excavation at no extra cost to The City.
- .11 Correct areas over-excavated by error at no extra cost to The City.
- .12 Remove excavated material from site.

3.4 Field Quality Controls

- .1 Field inspection will be performed under provisions of Section 01450.
- .2 Provide for visual inspection of bearing surfaces.

END OF SECTION

PART 1 GENERAL

1.1 Section Includes

- .1 Backfilling for sewer and watermain trenches.
- .2 Backfilling for paving and landscaping.

1.2 Related Sections

- .1 Section 02222 – Excavation and Backfilling - Buildings
- .2 Section 02513 - Asphalt Paving.
- .3 Section 02911 - Topsoil and Finish Grading.

PART 2 PRODUCTS

2.1 Materials

- .1 Granular Fill Materials: crushed, pit run or screened stone, gravel or sand consisting of hard durable particles free from clay lumps, cementation, organic material, frozen material or other deleterious substances.
- .2 Type of fill and gradations to be within the following limits:

Type A (Utility Trench Backfill)

| Sieve Designation | Type A |
|--------------------------|---------------|
| 3 inch | 100 |
| 1 inch | 80 – 100 |
| 3/8 inch | --- |
| ¼ inch | 40 – 70 |
| No. 4 | 25 – 50 |
| No. 10 | --- |
| No. 50 | 10 – 35 |
| 200 | 5 – 30 |

Type B and C (Fill For Roadways, Parking Lots to be Crushed Limestone)

| Sieve Designation | Percent Passing | | |
|-------------------|-----------------|----------------|-------------|
| | Type B | | Type C |
| | 2 in. Sub-base | 6 in. Sub-base | Base Course |
| 6 inch | | 90-100 | --- |
| 4 inch | | 75-90 | --- |
| 2 inch | 100 | --- | --- |
| 1 inch | --- | 50 | --- |
| ¾ inch | --- | --- | 100 |
| No. 4 | 25 – 80 | --- | 40 - 70 |
| No. 8 | --- | --- | 25 – 60 |
| No. 50 | --- | --- | 8 – 25 |
| 200 | 5 – 18 | --- | 6 - 17 |

Type D Fill (Sand)

| Sieve Size | Percent Passing |
|------------|-----------------|
| 3/8 inch | 100 |
| No. 4 | 90 - 100 |
| No. 50 | 25 – 60 |
| 200 | 0 – 3 |

- .3 Type E fill: selected material from excavation or other sources, approved by Contract Administrator for use intended, unfrozen and free from rocks larger than 2 inches, cinders, ashes, sods, refuse or other deleterious materials.
- .4 Unshrinkable fill proportioned and mixed to provide:
 - .1 Maximum compressive strength of 30 to 90 psi at 28 days.
 - .2 Maximum Portland Cement Content of 50 lbs/yd³.
 - .3 Portland Cement: Type 50.
 - .4 Maximum Aggregate size of 40 mm.

PART 3 EXECUTION

3.1 Preparation

- .1 Do not proceed with backfill operations until Contract Administrator has inspected and approved installations.
- .2 Areas to be backfilled are to be free from debris, snow, ice, water and frozen ground.
- .3 Do not use backfill material which is frozen or contains ice, snow or debris.

3.2 Fill Types And Compaction

- .1 Use fill types indicated as specified below. Compaction densities are standard proctor densities obtained from ASTM D698.
- .2 In landscaped areas use Type E native fill compacted to 95% density.
- .3 In utility trenches use Type D fill to a maximum of 8 inches above pipe, then Type A to bottom of pavement structure, compact to 98% standard proctor density.
- .4 Under roadway or parking lots use Type B and Type C fill to the specified depths compacted to 100% standard proctor density.

3.3 Backfilling

- .1 Place backfill in uniform layers not exceeding 6 inches for parking lot and roadways.
- .2 Do not backfill around or over cast-in-place concrete within 48 hours after placing of concrete.
- .3 Place layers simultaneously on both sides of installed Work to equalize loading.
- .4 Where temporary unbalanced earth pressures are liable to develop on walls or other structures:
 - .1 Permit concrete to cure for minimum 7 days or until it has sufficient strength to withstand earth and compaction pressure.
 - .2 Erect bracing or shoring to counteract unbalance, and leave in place until removal is approved by Contract Administrator.
- .5 Remove waste materials and debris, trim and correct defects as directed by Contract Administrator at no cost to The City.

3.4 Sub-Grade

- .1 Proof roll entire sub-grade prior to placement of fill material to verify sub-grade condition.
- .2 Correct defective areas as directed by the Contract Administrator.
- .3 Place backfill and/or grade parking lot to within one inch of design elevations but not uniformly high or low.
- .4 Compact sub-grade for parking lot to 95% Standard Proctor Density.
- .5 Obtain approval of Contract Administrator prior to placing sub-base material.

3.5 Field Quality Controls

- .1 Field inspection will be performed under provisions of Section 01450.
- .2 Provide for visual inspection of all backfill areas.

END OF SECTION

PART 1 GENERAL

1.1 References

- .1 American Society for Testing and Materials (ASTM)
 - .1 ASTM D698-91(1998), Test Method for Laboratory Compaction Characteristics of Soil Using Standard Effort (600 kN-m/m³).

1.2 Existing Conditions

- .1 Examine subsurface investigation report which is available for inspection at Contract Administrator's office.
- .2 Known underground and surface utility lines and buried objects are as indicated on site plan.

1.3 Protection

- .1 Protect and/or transplant existing trees, pavement, and surface or underground utility lines which are to remain as directed by Contract Administrator. If damaged, restore to original or better condition unless directed otherwise.
- .2 Maintain access roads to prevent accumulation of construction related debris on roads.

PART 2 PRODUCTS

2.1 Materials

- .1 Fill material: Type 1 and 2.
- .2 Excavated or graded material existing on site may be suitable to use as fill for grading Work if approved by Contract Administrator.

PART 3 EXECUTION

3.1 Stripping of Topsoil

- .1 Do not handle topsoil while in wet or frozen condition or in any manner in which soil structure is adversely affected as determined by Contract Administrator.
- .2 Commence topsoil stripping of areas as indicated after area has been cleared of grasses and removed from site.
- .3 Strip topsoil to depths as indicated. Roto-till weeds and grasses and retain as topsoil on site. Avoid mixing topsoil with subsoil.
- .4 Stockpile in locations as directed by Contract Administrator. Stockpile height not to exceed 2 metres.

- .5 Dispose of unused topsoil off site.

3.2 Grading

- .1 Rough grade to levels, profiles, and contours allowing for surface treatment as indicated.
- .2 Rough grade to following depths below finish grades:
 - .1 as indicated for grassed areas and asphalt paving, concrete paving, walks, and precast paving units.
- .3 Slope rough grade away from building as indicated.
- .4 Grade ditches to depth required for maximum run-off.
- .5 Prior to placing fill over existing ground, scarify surface to depth of 150 mm. Maintain fill and existing surface at approximately same moisture content to facilitate bonding.
- .6 Compact filled and disturbed areas to maximum dry density to ASTM D698, as follows:
 - .1 85% under landscaped areas.
 - .2 95 % under paved and walk areas.
- .7 Do not disturb soil within branch spread of trees or shrubs to remain.

3.3 Testing

- .1 Inspection and testing of soil compaction will be carried out by testing laboratory designated by ULC. Costs of tests will be paid by the City. Refer to Sections and 01450 - Quality Control.
- .2 Submit testing procedure, frequency of tests, testing laboratory as designated by ULC or certified testing personnel to Contract Administrator for review.

3.4 Surplus Material

- .1 Remove surplus material and material unsuitable for fill, grading or landscaping as directed by Contract Administrator.

END OF SECTION

PART 1 GENERAL

1.1 Related Sections

- .1 Section 00200 – Geotechnical Report.
- .2 Section 03200 - Concrete Reinforcement.
- .3 Section 03300 – Cast-in-Place Concrete.

1.2 References

- .1 CAN/CSA-A23.2-M90, Methods of Test for Concrete
- .2 CAN/CSA-G30.18-M92, Billet Steel Bars for Concrete Reinforcement.

1.3 Source Quality Control

- .1 Concrete tests to CAN/CSA-A23.2, refer to drawings.
- .2 Minimum 48 hours of notification to Public Works Department, Building Services Division (Mr. B. Kazun 986-7072) is required for placing of any piles. All construction Work will be halted if notice is not adhered to.

PART 2 PRODUCTS

2.1 Materials

- .1 Concrete mixes and materials: to Section 03300 – Cast-in-Place Concrete.
- .2 Reinforcing steel: to CAN/CSA-G30.18 and Section 03200 – Concrete Reinforcement.

PART 3 EXECUTION

3.1 Field Records

- .1 Maintain piling record for each pile, including date, depth of pile, top of pile elevation.
- .2 Provide Contract Administrator with three copies of records.

3.2 Installation

- .1 Confirm location of all sub-grade services prior to commencing drilling operations.
- .2 Bore holes to diameters and depths as indicated.
- .3 Protective steel casing:

- .1 Where required, use steel protective casing. Ensure penetration of casing to required depths either by self mass or driving.
- .4 Dispose of excavated materials.
- .5 A qualified Geotechnical Engineer may, at the Contract Administrator's discretion, inspect pile excavation prior to placing of concrete. Remove loose material, foreign matter and water as directed by Geotechnical Engineer. Geotechnical Engineer to be paid for by the City.
- .6 Install steel reinforcement in accordance with Section 03200 – Concrete Reinforcement and as indicated.
- .7 Fill pile excavations with concrete to elevations as indicated. Place concrete in one continuous pour in accordance with Section 03300 – Cast-in-Place Concrete.

END OF SECTION

PART 1 GENERAL

1.1 Section Includes

- .1 Installation of watermain pipe.
- .2 Installation of services and appurtenances.

1.2 Related Sections

- .1 Section 02222 – Excavation.
- .2 Section 02223 – Backfilling.

1.3 Project Record Documents

- .1 Accurately record the location and level of watermain installed by horizontal dimensions, and elevation of inverts.
- .2 Provide material and test certificate as per current NFPA standards, upon completion of the watermain installation.

PART 2 PRODUCTS

2.1 Materials

- .1 All pipe, valves, fittings and miscellaneous items shall conform to the requirements of the latest edition of the “City of Winnipeg, Standard Construction Specifications.”

2.2 Plastic Pipe And Fittings

- .1 Polyvinyl chloride (PVC) pressure pipe to the requirements of AWWA C900 Class 150, bell and spigot.

2.3 Gate Valves And Valve Boxes

- .1 Valves to open counter – clockwise with “BLACK” operating nut.
- .2 Valves to AWWA C500 resilient seat gate valve with non-rising stem.
- .3 Valve boxes to have a cast iron hinged upper section, top marked “WATER” with a PVC DR18 C900 valve box bottom
- .4 Top of valve operating extension rod to be no less than 6” below cover and no more than 18”.

2.4 Accessories

- .1 Provide sand bedding and granular backfill material as required to complete the Work.
- .2 Provide sulphate resistant concrete mixes for thrust blocks and underground Works.

PART 3 EXECUTION

3.1 Preparation

- .1 Inspect all materials for defects. Remove defective materials from site.
- .2 Provide trench alignment and depth of not less than 8.5 feet from finished grade to pipe inverts. Obtain Contract Administrators approval prior to placement of bedding material and pipe.
- .3 Slope bed to provide continuous uniform bearing surface for pipe.

3.2 Installation Of Pipes

- .1 Install pipes, fittings, valves and appurtenances in accordance with manufacturer's instructions proceeding from point of supply.
- .2 Confirm location of water service at the building with Contractor prior to commencing installation procedures.
- .3 Terminate building water service 3 feet outside building wall.
- .4 Place and compact backfill material to at least 95% standard proctor. under paved areas and 90% standard proctor in landscaped areas.

3.3 Leakage Testing

- .1 Open control valves and flush out system with a full head of water.
- .2 Apply test pressure of 150 psi for a period of 1 hour.
- .3 Inspect system for leakage and make necessary repairs.
- .4 Repeat test until all defects have been corrected.

3.4 Disinfection

- .1 Complete disinfection of all potable water supply lines.

END OF SECTION

PART 1 GENERAL

1.1 Section Includes

- .1 Installation of sanitary and storm sewer pipes.

1.2 Related Sections

- .1 Section 02222 – Excavation.
- .2 Section 02223 – Backfilling.

1.1 Project Record Documents

- .1 Accurately record the location and level of sewers installed by horizontal dimensions, elevation of inverts and slope gradients.

PART 2 PRODUCTS

2.1 Materials

- .1 All pipe and fittings shall conform to the latest edition of the “City of Winnipeg, Standard Construction Specifications.”
- .2 All 8” and 10” pipe shall meet or exceed the manufacturers requirements for polyvinyl chloride (PVC) ASTM D3034 SDR 35.
- .3 Provide sulfate resistant concrete for all underground Works.

PART 3 EXECUTION

3.1 Installation

- .1 Obtain Contract Administrators approval of pipe, trench alignment and depth prior to installation and placement of bedding material and pipe.
- .2 Shape bed to provide continuous uniform bearing surface for pipe.
- .3 Install pipes and fittings in accordance with manufacturer’s instructions proceeding upstream.
- .4 Place and compact backfill material to at least 98% standard proctor under paved areas and 95% standard proctor in landscaped areas.

END OF SECTION

PART 1 GENERAL

1.1 Related Sections

- .1 Section 02222 – Excavating.
- .2 Section 02223 – Backfilling.

1.2 References

- .1 Canadian Standards Association (CSA)
 - .1 CAN/CSA-A23.1-94, Concrete Materials and Methods of Concrete Construction.
 - .2 CAN/CSA-B182.1-M92, Plastic Drain and Sewer Pipe and Pipe Fittings.
 - .3 CAN3-G401-93, Corrugated Steel Pipe Products.
- .2 Canadian General Standards Board (CGSB)
 - .1 CAN/CGSB-34.22-94, Asbestos-Cement Drain Pipe .
- .3 American Society for Testing and Materials (ASTM)
 - .1 ASTM D 698-91, Test Method for Laboratory Compaction Characteristics of Soil Using Standard Effort (12,400 ft-lbf/ft³ (600 kN-m/m³)).

1.3 Site Conditions

- .1 Examine sub-surface investigation report included in Section 00200.
- .2 Known underground utility lines and buried objects are as indicated on plans.

PART 2 PRODUCTS

2.1 Bedding and Surround Materials

- .1 Coarse filter aggregate: to CAN/CSA-A23.1, Table 2, Group 1 20-5 mm.
- .2 Fine filter aggregate: to CAN/CSA-A23.1, Table 1.
- .3 Flexible plastic tubing and fittings. Perforated and non-perforated nominal inside diameter as indicated.
- .4 Geo textile filter.
- .5 Rigid board building insulation, 112 kg/m³ density, unfaced.
- .6 Cleanouts: as indicated.

2.2 Backfill Material

- .1 Type 2, in accordance with Section 02223 - Backfilling.
- .2 Excavated or graded material existing on site may be suitable to use if approved by Contract Administrator.

PART 3 EXECUTION

3.1 Inspection

- .1 Ensure graded subgrade and base conforms with required drainage pattern before placing bedding material.
- .2 Ensure improper slopes, unstable areas, areas requiring additional compaction or other unsatisfactory conditions are corrected to approval of Contract Administrator.
- .3 Ensure foundation wall and dampproofing have been installed and approved by Contract Administrator before placing bedding material.

3.2 Bedding Preparation

- .1 Cut trenches in subgrade and place bedding materials in uniform layers not exceeding 150 mm compacted thickness to depth as indicated.
- .2 Shape bed true to grade and to provide continuous, uniform bearing surface for tubing.
- .3 Shape transverse depressions, as required, to suit joints.
- .4 Compact each layer full width of bed to at least 95% of corrected maximum dry density.
- .5 Fill excavation below design elevation of bottom of specified bedding with compacted bedding material.

3.3 Pipe or Tubing Installation

- .1 Ensure tubing interior and coupling surfaces are clean before laying.
- .2 Lay perforated tubing minimum to slope of 1:100. Face perforations and coupling slots downward.
- .3 Lay non-perforated tubing to slope of 1:50 from perforated tubing to disposal area. Make joints watertight.
- .4 Grade bedding to establish tubing slope.
- .5 Install end plugs at ends of collector drains to protect tubing ends from damage and ingress of foreign material.

- .6 Connect non-perforated tubing to sump pit by appropriate adapters as indicated.
- .7 Provide cleanouts on non-perforated tubing at changes of tubing direction and in runs greater than 15 m.
- .8 Provide flush cleanouts where directed by Contract Administrator.
- .9 Connect drainage system as indicated.

3.4 Pipe or Tubing Surround Material

- .1 Upon completion of tubing laying and after Contract Administrator has inspected Work in place, surround and cover tubing and install geotextile filter as indicated.
- .2 Hand place surround material in uniform layers not exceeding 150 mm compacted thickness, as indicated. Do not drop material within 5 m of tubing.
- .3 Place layers uniformly and simultaneously on each side of tubing.
- .4 Compact each layer from tubing invert to mid-height of tubing to at least 95% of corrected maximum dry density.
- .5 Compact each layer from mid-height of tubing to underside of backfill to at least 90% of corrected maximum dry density.

3.5 Backfill Material

- .1 Place backfill material above tubing surround in uniform layers not exceeding 150 mm compacted thickness up to grades as indicated.
- .2 Under paving and walks, compact backfill to at least 95% corrected maximum dry density. In other areas, compact to at least 90% corrected maximum dry density.

END OF SECTION

PART 1 GENERAL

1.1 Section Includes

- .1 Installation of manholes and catchbasins at the locations shown on the drawings.

1.2 Related Sections

- .1 Section 02222 – Excavation.
- .2 Section 02223 – Backfilling.
- .3 Section 02530 – Sewer Services.

1.3 Project Record Documents

- .1 Accurately record the location of all manholes and catchbasins by horizontal dimensions and elevation of inverts.

PART 2 PRODUCTS

2.1 Materials

- .1 Manholes and catch basins shall be precast concrete to C76 Class II or ASTM C478, complete with precast concrete floor and ladder rungs.
- .2 Manhole frames shall include “solid” covers.
- .3 Catch basin frames shall include “open” covers.
- .4 Refer to the latest edition of the “City of Winnipeg Standard Construction Specification,” for all approved products.
- .5 Provide sand bedding and granular backfill as required to complete the Work.

PART 3 EXECUTION

3.1 Installation

- .1 Install precast section on granular bedding.
- .2 Install pipes to units and make water tight. Plug lifting holes with concrete.
- .3 Wrap all units with one layer of polyethylene sheet from below the frame to a depth of 9.0 feet.
- .4 Place frame and cover on top section to design grade. Adjust as required with concrete rings or a maximum of 2 courses of bricks. Add cement mortar to make smooth and watertight.

- .5 Prevent debris from entering system. Clean units of debris upon completion of asphalt paving operation.

END OF SECTION

PART 1 GENERAL

1.1 Section Includes

- .1 Installation of curb and curb and gutter.

1.2 Related Sections

- .1 Section 01450 – Quality Control.
- .2 Section 02513 – Asphalt Paving.

PART 2 PRODUCTS

2.1 Materials

- .1 All materials shall be approved by the Contract Administrator at least 10 days before any construction is undertaken.
- .2 Concrete shall conform to the requirements within the latest edition of the City of Winnipeg Standard Construction Specification.
- .3 Cement shall be Type 10 Normal Portland Cement.
- .4 Admixtures: No admixtures, other than Air Entraining Agent and Type WN Water Reducing Agent shall be used without the written authorization of the Contract Administrator.
- .5 Reinforcing Steel: All reinforcing steel shall conform to the requirement of CSA Standard G30.12M. Deformed reinforcing bars shall be Grade 400 deformed bars.
- .6 Curing compound shall be either Type 1-D, clear or translucent with fugitive dye, or Type 2 white-pigmented, liquid membrane form curing compound.
- .7 Form coating shall be of a type approved by the Contract Administrator.
- .8 Concrete for Curbs:
 - .1 Min. Compressive strength @ 28da. = 4600 psi.
 - .2 Min. Cement content = 20 lb/ft³.
 - .3 Max. Water/cement ratio = 0.45.
 - .4 Max. Slump = 3 inches.
 - .5 Aggregate size: ¾ inch nominal.
 - .6 Air content = 5.0% to 8.0%.

PART 3 EXECUTION

3.1 Preparation

- .1 Obtain Contract Administrator's approval of subgrade before placing granular base.
- .2 Place granular base material to lines, widths, and depths as indicated.
- .3 Compact granular base to at least 100% of standard proctor density.
- .4 Obtain Contract Administrator's approval of granular base and reinforcing steel prior to placing concrete.
- .5 Place concrete and finish exposed surfaces to a smooth uniform finish, free of open texturing and exposed aggregate. Do not Work more mortar to surface than required. Do not use neat cement as a drier to facilitate drying.
- .6 Provide edging as indicated with 1-inch radius edging tool.
- .7 Install expansion joints at intervals of 6 feet.
- .8 Apply curing compound evenly to form continuous film in accordance with manufacturer's requirements.

3.2 Tolerances

- .1 Finish surfaces to within ¼ inch in 10 feet as measured with 10-foot straightedge placed on surface.

3.3 Field Quality Control

- .1 Field Inspections will be performed in accordance with the City of Winnipeg Standard Construction Specifications.

3.4 Protection

- .1 Protect curbs from damage for a minimum of 5 days following placement or until concrete has attained a strength of 32 MPa.

END OF SECTION

PART 1 GENERAL

1.1 Related Sections

- .1 Section 01330 - Submittal Procedures.
- .2 Section 01355 - Waste Management and Disposal.
- .3 Section 03300 - Cast-in-Place Concrete.
- .4 Section 09912 - Exterior Painting.

1.2 Measurement Procedures

- .1 Measure supply and erection of chain link fence in metres erected including gates.
- .2 Measure supply and erection of chain link fence gates as units of each size erected.

1.3 References

- .1 American Society for Testing and Materials (ASTM)
 - .1 ASTM A53/A53M-01, Standard Specification for Pipe, Steel, Black and Hot-Dipped, Zinc-Coated Welded and Seamless.
 - .2 ASTM A90/A90M-01, Standard Test Method for Mass of Coating on Iron and Steel Articles with Zinc or Zinc-Alloy Coatings.
 - .3 A653/A653M-01, Standard Specification for Steel Sheet, Zinc-Coated (Galvanized) or Zinc-Iron Alloy-Coated (Galvannealed) by the Hot-Dip Process.
 - .4 ASTM C618-00, Standard Specification for Coal Fly Ash and Raw or Calcined Natural Pozzolan for Use as a Mineral Admixture in Concrete.
- .2 Canadian General Standards Board (CGSB)
 - .1 CAN/CGSB-138.2-96, Steel Framework for Chain Link Fence.
 - .2 CAN/CGSB-138.3-96, Installation of Chain Link Fence.
 - .3 CAN/CGSB-138.4-96, Gates for Chain Link Fence.
 - .4 CAN/CGSB-1.181-99, Ready-Mixed Organic Zinc-Rich Coating.
- .3 Canadian Standards Association (CSA)
 - .1 CSA-A23.1/A23.2-00(June 2001), Concrete Materials and Methods of Concrete Construction/Methods of Test for Concrete.
 - .2 CAN/CSA-G164-M92(R1998), Hot Dip Galvanizing of Irregularly Shaped Articles.
 - .3 CAN/CSA-A3000-98(April 2001), Cementitious Materials Compendium. Includes:
 - .1 CAN/CSA-A23.5-98, Supplementary Cementing Materials

1.4 Shop Drawings

- .1 Submit shop drawings in accordance with Section 01330 - Submittal Procedures.
- .2 Drawings to indicate: details at corners and gates.

1.5 Waste Management and Disposal

- .1 Separate and recycle waste materials in accordance with Section 01355 - Waste Management and Disposal.
- .2 Collect and separate for disposal paper, plastic, corrugated cardboard, packaging material [in appropriate on-site bins] for recycling in accordance with Waste Management Plan.
- .3 Place materials defined as hazardous or toxic in designated containers.
- .4 Divert unused metal and wiring materials from landfill to metal recycling facility as approved by Contract Administrator.
- .5 Unused paint or coating material must be disposed of at an official hazardous material collections site as approved by Contract Administrator.
- .6 Do not dispose of unused paint material into sewer system, into streams, lakes, onto ground or in any other location where it will pose health or environmental hazard.
- .7 Fold up metal banding, flatten and place in designated area for recycling.

PART 2 PRODUCTS

2.1 Materials

- .1 Concrete mixes and materials: in accordance with Section 03300- Cast-in-Place Concrete.
 - .1 Nominal coarse aggregate size: 20-5.
 - .2 Compressive strength: 20 MPa minimum at 28 days.
 - .3 Additives: fly ash to CAN/CSA-A23.5 ASTM C618.
- .2 Posts, braces and rails: to CAN/CGSB-138.2, galvanized steel pipe. Dimensions as indicated.
- .3 Tension bar: to ASTM A653/A653M, 5 x 20 mm minimum galvanized steel.
- .4 Gates: to CAN/CGSB-138.4.
- .5 Gate frames: to ASTM A53/A53M, galvanized steel pipe, standard weight 45 mm outside diameter pipe for outside frame, 35mm outside diameter pipe for interior bracing.
 - .1 Fabricate gates as indicated with electrically welded joints, and hot-dip galvanized after welding.
 - .2 Fasten fence fabric to gate with twisted selvage at top.

- .3 Furnish gates with galvanized malleable iron hinges, latch and latch catch with provision for padlock which can be attached and operated from either side of installed gate.
- .6 Fittings and hardware: to CAN/CGSB-138.2, cast aluminum alloy, galvanized steel or malleable or ductile cast iron. Tension bar bands: 3 x 20 mm minimum galvanized steel or 5 x 20 mm minimum aluminum. Post caps to provide waterproof fit, to fasten securely over posts and to carry top rail. Turnbuckles to be drop forged.
- .7 Organic zinc rich coating: to CAN/CGSB-1.181.

2.2 Finishes

- .1 Galvanizing:
 - .1 For pipe: 550 g/m² minimum to ASTM A90.
 - .2 For other fittings: to CAN/CSA-G164.

PART 3 EXECUTION

3.1 Grading

- .1 Remove debris and correct ground undulations along fence line to obtain smooth uniform gradient between posts. Provide clearance between bottom of fence and ground surface of 30 mm to 50 mm.

3.2 Erection of Fence

- .1 Erect fence along lines as indicated and to CAN/CGSB-138.3.
- .2 Excavate post holes by methods approved by Contract Administrator.
- .3 Space line posts 3 m apart maximum, measured parallel to ground surface.
- .4 Install corner post where change in alignment exceeds 10 deg .
- .5 Install end posts at end of fence and at buildings. Install gate posts on both sides of gate openings.
- .6 Place concrete in post holes then embed posts into concrete to depths as indicated by Contract Administrator. Extend concrete 50 mm above ground level and slope to drain away from posts. Brace to hold posts in plumb position and true to alignment and elevation until concrete has set.
- .7 Install brace between end and gate posts and nearest line post, at inclination as indicated. Install braces on both sides of corner and straining posts in similar manner.
- .8 Install overhang tops and caps.
- .9 Install top rail between posts and fasten securely to posts and secure waterproof caps and overhang tops.

- .10 Install bottom tension wire, stretch tightly and fasten securely to end, corner, gate and straining posts with turnbuckles and tension bar bands.

3.3 Installation of Gates

- .1 Install gates in locations as indicated.
- .2 Level ground between gate posts and set gate bottom approximately 40 mm above ground surface.
- .3 Determine position of centre gate rest for double gate. Cast gate rest in concrete as directed. Dome concrete above ground level to shed water.
- .4 Install gate stops where indicated.

3.4 Touch up

- .1 Clean damaged surfaces with wire brush removing loose and cracked coatings. Apply two coats of organic zinc-rich paint to damaged areas in accordance with Section 09912 - Exterior Painting. Pre-treat damaged surfaces according to manufacturers' instructions for zinc-rich paint.

3.5 Cleaning

- .1 Clean and trim areas disturbed by operations. Dispose of surplus material and replace damaged turf with sod as directed by Contract Administrator.

END OF SECTION

PART 1 GENERAL

1.1 Related Sections

- .1 Section 02311 - Site Grading : Preparation of sub-grade and excavation.

1.2 Measurement Procedures

- .1 Preparation of sub-grade for placing of topsoil will not be measured for payment.
- .2 Topsoil stripping will be measured by Contract Administrator in cubic metres of stockpiled topsoil and volume will be determined by average end area method.
- .3 Placing of topsoil will be measured in cubic metres removed from stockpile. Stockpiles will be measured by Contract Administrator and volume of topsoil removed calculated by average end area method.
- .4 Supply and application of soil amendments, including fertilizer, will be measured in standard commercial units of weight/volume as determined by Contract Administrator.
- .5 Supplying, placing and spreading topsoil will be measured in cubic metres determined by truck box measurement as loaded. Truck box capacity will be determined by Contract Administrator.
- .6 Supplying, placing and spreading topsoil will be measured in cubic metres as determined from actual surface area covered and depth of topsoil specified. Specified depth of topsoil shall be measured and approved by Contract Administrator after settlement and consolidation as specified.
- .7 Finish grading will be measured in square metres from actual surface measurements as determined by Contract Administrator.

1.3 Definitions

- .1 COMPOST: A mixture of soil and decomposing organic matter used as a fertilizer, mulch, or soil conditioner. Compost is processed organic matter containing 40% or more organic matter as determined by the Walkley-Black or LOI test. Product must be sufficiently decomposed (i.e. stable) so that any further decomposition does not adversely affect plant growth (C:N ratio below (25) (50)), and contain no toxic or growth inhibiting contaminants. Composed bio-solids must meet the requirements of the Guidelines for Compost Quality, Category (A) (B) produced by the Canadian Council of the Ministers of the Environment (CCME), January 1996.

PART 2 PRODUCTS

2.1 Topsoil

- .1 Topsoil for seeded areas: mixture of particulates, micro organisms and organic matter which provides suitable medium for supporting intended plant growth.

- .1 Soil texture based on The Canadian System of Soil Classification, to consist of 20 to 30 % sand, minimum 7 % clay, and contain 2 to 10 % organic matter by weight.
- .2 Contain no toxic elements or growth inhibiting materials.
- .3 Finished surface free from:
 - .1 Debris and stones over 50 mm diameter.
 - .2 Course vegetative material, 10 mm diameter and 100 mm length, occupying more than 2% of soil volume.
- .4 Consistence: friable when moist.

2.2 Soil Amendments

- .1 Fertilizer:
 - .1 Fertility: major soil nutrients present in following amounts:
 - .2 Nitrogen (N): 20 to 40 micrograms of available N per gram of topsoil.
 - .3 Phosphorus (P): 40 to 50 micrograms of phosphate per gram of topsoil.
 - .4 Potassium (K): 75 to 110 micrograms of potassium per gram of topsoil.
 - .5 Calcium, magnesium, sulfur and micro-nutrients present in balanced ratios to support germination and/or establishment of intended vegetation.
 - .6 Ph value: 6.5 to 8.0.
- .2 Peatmoss:
 - .1 Derived from partially decomposed species of Sphagnum Mosses.
 - .2 Elastic and homogeneous, brown in colour.
 - .3 Free of wood and deleterious material which could prohibit growth.
 - .4 Shredded particle minimum size: 5 mm.
- .3 Sand: washed coarse silica sand, medium to course textured.
- .4 Organic matter: compost Category A, unprocessed organic matter, such as rotted manure, hay, straw, bark residue or sawdust, meeting the organic matter, stability and contaminant requirements.
- .5 Limestone:
 - .1 Ground agricultural limestone.
 - .2 Gradation requirements: percentage passing by weight, 90% passing 1.0 mm sieve, 50% passing 0.125 mm sieve.
- .6 Fertilizer: industry accepted standard medium containing nitrogen, phosphorous, potassium and any other micro-nutrients suitable to the specific plant species or application or defined by the soil test.

2.3 Source Quality Control

- .1 Advise Contract Administrator of sources of topsoil to be utilized with sufficient lead time for testing.
- .2 Contractor is responsible for amendments to supply topsoil as specified.
- .3 Soil testing by recognized testing facility for PH, P and K, and organic matter.

PART 3 EXECUTION

3.1 Preparation of Existing Grade

- .1 Verify that grades are correct. If discrepancies occur, notify Contract Administrator and do not commence Work until instructed by Contract Administrator.
- .2 Grade soil, eliminating uneven areas and low spots, ensuring positive drainage.
- .3 Remove debris, roots, branches, stones in excess of 50 mm diameter and other deleterious materials. Remove soil contaminated with calcium chloride, toxic materials and petroleum products. Remove debris which protrudes more than 75 mm above surface. Dispose of removed material off site.
- .4 Cultivate entire area which is to receive topsoil to minimum depth of 100 mm. Cross cultivate those areas where equipment used for hauling and spreading has compacted soil.

3.2 Placing and Spreading of Topsoil/Planting Soil

- .1 Place topsoil after Contract Administrator has accepted sub-grade.
- .2 Spread topsoil in uniform layers not exceeding 150 mm.
- .3 For sodded areas keep topsoil 15 mm below finished grade.
- .4 Spread topsoil as indicated to following minimum depths after settlement.
 - .1 150 mm for seeded areas.
 - .2 135 mm for sodded areas.
- .5 Manually spread topsoil/planting soil around trees, shrubs and obstacles.

3.3 Finish Grading

- .1 Grade to eliminate rough spots and low areas and ensure positive drainage. Prepare loose friable bed by means of cultivation and subsequent raking.
- .2 Consolidate topsoil to required bulk density using equipment approved by Contract Administrator. Leave surfaces smooth, uniform and firm against deep foot printing.

3.4 Acceptance

- .1 Contract Administrator will inspect and test topsoil in place and determine acceptance of material, depth of topsoil and finish grading.

3.5 Surplus Material

- .1 Dispose of materials except topsoil not required where directed by Contract Administrator.

END OF SECTION

PART 1 GENERAL

1.1 Related Sections

- .1 Section 02311 – Site Grading.
- .2 Section 02933 – Sodding.

1.2 Product Data

- .1 Submit product data in accordance with Section 01330 - Submittal Procedures.
- .2 Provide product data for:
 - .1 Seed
 - .2 Fertilizer

1.3 Scheduling

- .1 Schedule completion of Work immediately prior to hydraulic mulching.

PART 2 PRODUCTS

2.1 Grass Seed

- .1 Canada "Certified" seed, "Canada No. 1 Lawn Grass Mixture" in accordance with Government of Canada "Seeds Act" and "Seeds Regulations".
 - .1 Grass seed mixture.
 - .1 70 % Kentucky Blue Grass, 30% Red Fescue .
- .2 In packages individually labelled in accordance with "Seeds Regulations" and indicating name of supplier.

2.2 Water

- .1 Free of impurities that would inhibit germination and growth.
- .2 Supplied by City at designated source.

2.3 Fertilizer

- .1 To Canada "Fertilizers Act" and "Fertilizers Regulations".
- .2 Complete synthetic fertilizer with guaranteed minimum analysis as specified.

PART 3 EXECUTION

3.1 Quality of Work

- .1 Do not perform Work under adverse field conditions as determined by Contract Administrator.
- .2 Remove and dispose of weeds; debris; stones 50 mm in diameter and larger; soil contaminated by oil, gasoline and other deleterious materials; off site or to a location as directed by Contract Administrator.

3.2 Seed Bed Preparation

- .1 Verify that grades are correct. If discrepancies occur, notify Contract Administrator.
- .2 Fine grade surface free of humps and hollows to smooth, even grade, to contours and elevations indicated to tolerance of plus or minus 20 mm, surface draining naturally.

3.3 Seed Placement

- .1 For manual seeding:
 - .1 Use "Cyclone" type manually operated seeder.
 - .2 Use manually operated, water ballast, landscaping type, smooth steel drum roller. Ballast as directed by Contract Administrator.
 - .3 Use equipment and method acceptable to Contract Administrator.
- .2 On cultivated surfaces, sow seed uniformly at rate of:
 - .1 1.5 kg/ 1000 m² lawn grass mixture.
- .3 Blend applications 150 mm into adjacent grass areas to form uniform surfaces.
- .4 Sow half of required amount of seed in one direction and remainder at right angles as applicable.
- .5 Incorporate seed by light raking in cross directions.

3.4 Fertilizing Program

- .1 Submit fertilizing program for approval of Contract Administrator.

3.5 Maintenance During Establishment Period

- .1 Perform following operations from time of seed application until acceptance by Contract Administrator:
 - .1 Water seeded area to maintain optimum soil moisture level for germination and continued growth of grass. Control watering to prevent washouts.
 - .2 Repair and reseed dead or bare spots to allow establishment of seed prior to acceptance.

- .3 Cut grass to 50 mm whenever it reaches height of 70 mm. Remove clippings which will smother grass.
- .4 Fertilize seeded areas after first cutting in accordance with fertilizing program. Spread half of required amount of fertilizer in one direction and remainder at right angles and water in well.
- .5 Control weeds by mechanical means utilizing acceptable integrated pest management practices.

3.6 Final Acceptance

- .1 Seeded areas will be accepted by Contract Administrator provided that:
 - .1 Areas are uniformly established and turf is free of rutted, eroded, bare or dead spots and free of weeds.
 - .2 Areas have been cut at least twice.
 - .3 Areas have been fertilized.
- .2 Areas seeded in fall will be accepted in following spring, one month after start of growing season provided acceptance conditions are fulfilled.

3.7 Maintenance During Warranty Period

- .1 Perform following operations from time of acceptance until end of warranty period:
 - .1 Water seeded area to maintain optimum soil moisture level for continued growth of grass. Control watering to prevent washouts.
 - .2 Repair and reseed dead or bare spots to satisfaction of Contract Administrator.
 - .3 Cut grass to 50 mm whenever it reaches height of 70 mm. Remove clippings which will smother grass.
 - .4 Fertilize seeded areas in accordance with fertilizing program. Spread half of required amount of fertilizer in one direction and remainder at right angles and water in well.
 - .5 Control weeds by mechanical means utilizing acceptable integrated pest management practices.

END OF SECTION

PART 1 GENERAL

1.1 Related Sections

- .1 Section 02911 - Topsoil and Finish Grading.

1.2 Scheduling

- .1 Schedule sod laying to coincide with preparation of soil surface.
- .2 Schedule sod installation when frost is not present in ground.

PART 2 PRODUCTS

2.1 Materials

- .1 Number One Turfgrass Nursery Sod: Sod that has been especially sown and cultivated in nursery fields as turfgrass crop.
 - .1 Turfgrass Nursery Sod types:
 - .1 Number One Kentucky Bluegrass Sod: Nursery Sod grown solely from seed of cultivars of Kentucky Bluegrass, containing not less than 50% Kentucky Bluegrass cultivars.
 - .2 Turfgrass Nursery Sod quality:
 - .1 Not more than 2 broadleaf weeds or 10 other weeds per 40 square metres.
 - .2 Density of sod sufficient so that no soil is visible from height of 1500 mm when mown to height of 50 mm.
 - .3 Mowing height limit: 35 to 65 mm.
 - .4 Soil portion of sod: 6 to 15 mm in thickness.
 - .2 Water:
 - .1 Supplied by City at designated source.
 - .3 Fertilizer:
 - .1 To Canada "Fertilizers Act" and "Fertilizers Regulations".
 - .2 Complete, synthetic, slow release with 65 % of nitrogen content in water-insoluble form.

2.2 Source Quality Control

- .1 Obtain approval from Contract Administrator of sod at source.
- .2 When proposed source of sod is approved, use no other source without written authorization.

PART 3 EXECUTION

3.1 Preparation

- .1 Verify that grades are correct and prepared in accordance with Section 02911 - Topsoil and Finish Grading. If discrepancies occur, notify Contract Administrator and do not commence Work until instructed by Contract Administrator.
- .2 Do not perform Work under adverse field conditions such as frozen soil, excessively wet soil or soil covered with snow, ice, or standing water.
- .3 Fine grade surface free of humps and hollows to smooth, even grade, surface to drain naturally.
- .4 Remove and dispose of weeds; debris; stones 50 mm in diameter and larger; soil contaminated by oil, gasoline and other deleterious materials off site.

3.2 Sod Placement

- .1 Lay sod within 24 hours of being lifted if air temperature exceeds 20°C.
- .2 Lay sod sections in rows, joints staggered. Butt sections closely without overlapping or leaving gaps between sections. Cut out irregular or thin sections with sharp implements.
- .3 Roll sod as directed by Contract Administrator. Provide close contact between sod and soil by light rolling. Use of heavy roller to correct irregularities in grade is not permitted.

3.3 Sod Placement on Slopes and Pegging

- .1 Install and secure geo-textile fabric in areas indicated, in accordance with manufacturer's instructions.
- .2 Start laying sod at bottom of slopes.
- .3 Peg sod on slopes with biodegradable pegs steeper than 3 horizontal to 1 vertical, within 1 m of catch basins and within 1 m of drainage channels and ditches to following pattern:
 - .1 100 mm below top edge at 200 mm on centre for first sod sections along contours of slopes.
 - .2 Not less than 3 pegs per square metre.
 - .3 Drive pegs to 20 mm above soil surface of sod sections.

3.4 Maintenance During Establishment Period

- .1 Perform following operations from time of installation until acceptance.
- .2 Water sodded areas in sufficient quantities and at frequency required to maintain optimum soil moisture condition to depth of 75 to 100 mm.
- .3 Cut grass to 50 mm when or prior to it reaching height of 75 mm. Remove clippings immediately.
- .4 Maintain sodded areas weed free 95%.

- .5 Fertilize areas in accordance with fertilizing program. Spread half of required amount of fertilizer in one direction and remainder at right angles [and water in well.

3.5 Acceptance

- .1 Turfgrass Nursery Sod areas will be accepted by Contract Administrator provided that:
 - .1 Sodded areas are properly established.
 - .2 Sod is free of bare and dead spots.
 - .3 No surface soil is visible from height of 1500 mm when grass has been cut to height of 50 mm.
 - .4 Sodded areas have been cut minimum 2 times prior to acceptance.
- .2 Areas sodded in fall will be accepted in following spring one month after start of growing season provided acceptance conditions are fulfilled.

3.6 Maintenance During Warranty Period

- .1 Perform following operations from time of acceptance until end of warranty period:
 - .1 Water sodded Turfgrass Nursery Sod areas at weekly intervals to obtain optimum soil moisture conditions to depth of 100 mm.
 - .2 Repair and resod dead or bare spots to satisfaction of Contract Administrator.
 - .3 Cut grass and remove clippings that will smother grass to height as follows:
 - .1 Turfgrass Nursery Sod:
 - .1 50 mm during normal growing conditions.
 - .2 Cut grass at 2 week intervals, but at intervals so that approximately one third of growth is removed in single cut.
 - .3 Eliminate weeds by mechanical means to extent acceptable to Contract Administrator.

END OF SECTION

PART 1 – GENERAL

1.1 Work Included

- .1 The Work included under this section shall conform to the industry standard and be accepted by the local construction and trade associations.

1.2 Quality Assurance

- .1 Construct and erect concrete formwork in accordance with CAN3-A23.1M00 and applicable construction safety regulations for place of Work.

PART 2 – PRODUCTS

2.1 Wood Form Materials

- .1 Plywood: Douglas Fir species; solid one side-tight face grade; sound undamaged sheets with clean true edges.

2.2 Prefabricated Forms

- .1 Steel Type: Minimum 16 gauge, well matched, tight fitting, and adequately stiffened to support weight of concrete without deflection detrimental to tolerances and appearance of finished concrete surfaces.
- .2 Tubular Column Type: Round, spirally wound laminated fiber materials, inside surface treated with a release agent; of sizes required.

2.3 Formwork Accessories

- .1 Form Ties: Snap-off metal type of fixed or adjustable length; minimum working strength of 13 KN when assembled; free of defects that will leave holes larger than 25mm in concrete surface. Design to be such that upon removal of forms no metal shall be less than 12mm from surface where surface is not visible and 30mm from surface where surface is to be visible in unfinished or finished space. Provide plastic setback plugs at exposed surfaces to seal off cone holes.
- .2 Form Release Agent: Colourless mineral oil which will not stain concrete or impair natural bonding or color characteristics of coating intended for use on concrete.
- .3 Fillets for Chamfered Corners: Rigid formed plastic type; 20mm x 20mm size; maximum possible lengths.

2.4 Concrete Accessories

- .1 Void Forms: Expanded paper composition forms; biodegradable cardboard; structurally sufficient to support weight of wet concrete mix until initial set; 150 mm thick. Waterproof waxed surfaces. Standard of acceptance: "Waxmat".

PART 3 – EXECUTION

3.1 Formwork Erection

- .1 Verify lines, levels and centers before proceeding with formwork. Ensure that dimensions agree with drawings.
- .2 Construct formwork, shoring and bracing to meet design and code requirements, so that resultant finished concrete conforms to required shapes, lines and dimensions.
- .3 Arrange and assemble formwork to permit dismantling and stripping so that concrete is not damaged during its removal.
- .4 Align joints and make watertight, to prevent leakage of mortar disfigured appearance of concrete. Keep form joints to a minimum.
- .5 Arrange forms to allow stripping without removal of principal shores, where and when these are required to remain in place.
- .6 Obtain Contract Administrator's review before framing openings in structural members, which are not indicated on drawings.
- .7 Provide bracing to ensure stability of formwork. Shore or strengthen previously constructed formwork liable to be overstressed by construction loads.
- .8 Provide chamfer strips on external corners of beams, columns and walls that are open to view.
- .9 Apply form release agent on formwork in accordance with manufacturer's recommendations. Apply prior to placing reinforcing steel, anchoring devices, and embedded items.
- .10 Do not apply form release agent where concrete surfaces will receive special finishes or applied coverings that are effected by agent. Soak inside surfaces of untreated forms with clean water. Keep surfaces wet prior to placing concrete.

3.2 Inserts, Embedded Parts, And Openings

- .1 Provide formed openings where required for pipes, conduits, sleeves, and other Work to be embedded in and passing through concrete members.
- .2 Locate and set in place items that will be cast directly into concrete.
- .3 Coordinate Work of other sections and cooperate with trade involved in forming and setting openings, slots, recesses, chases, sleeves, bolts, anchors, and other inserts. Do not perform Work unless specifically indicated on drawings or reviewed prior to installation.
- .4 Install concrete accessories in accordance with manufacturer's instructions; straight, level, and plumb. Ensure items are not disturbed during concrete placement.

- .5 Install void forms in accordance with manufacturer's recommendations. Protect forms from moisture before concrete placing. Protect forms from crushing during concrete placement.

3.3 Tolerances

- .1 Deviation from horizontal to maintain following maximum tolerances:
 - .1 6mm in 3m,
 - .2 9mm in 6m,
 - .3 20mm in 12m or more.
- .2 Deviation of building dimensions indicated on drawing and position of columns, walls and partitions: 6mm.
- .3 Deviation in cross sectional dimensioning of columns or beams or in thickness of slabs and walls: plus or minus 6mm.

3.4 Cleaning

- .1 Clean forms as erection proceeds, to remove foreign matter. Remove cuttings, shavings, and debris from within forms. Flush with water or use compressed air to remove remaining foreign matter. Ensure that water and debris drain to exterior through clean-out ports.
- .2 During cold weather, remove ice and snow from within forms. Do not use de-icing salts. Do not use water to clean out completed forms, unless formwork and concrete construction proceed within heat enclosure. Use compressed air or other means to remove foreign matter.

3.5 Form Removal

- .1 Do not remove forms, shores and bracing until concrete has gained sufficient strength to carry its own weight, and construction and design load which are liable to be imposed upon it. Verify strength of concrete by compressive test results.
- .2 Remove formwork progressively and in accordance with code requirements and so that no shock loads or unbalanced loads are imposed on structure.
- .3 Loosen forms carefully. Do not wedge pry bars, hammers, or tools against concrete surfaces.
- .4 Store removed forms, for exposed architectural concrete, in manner that surfaces to be in contact with fresh concrete will not be damaged. Marked or scored forms will be rejected.
- .5 Re-shore structural members where required due to design requirements or construction conditions and as required to permit progressive construction. Remove load supporting forms only when concrete has attained 75 percent of required 28 day compressive strength, provide construction is re-shored and in no case earlier than four days after completion of pour.

.6 Remove forms not directly supporting weight of concrete as soon as stripping operations will not damage concrete.

.7 The following chart may be used as a guide for removal of forms:

CONCRETE CURING TEMPERATURE (°C)

| | | 25°-35° | 15°-20° | 10°-15° |
|----|---|---------|---------|---------|
| .1 | Wall and beam sides and other surfaces not supporting weight of concrete. | 2 Days | 3 Days | 4 Days |
| .2 | Beam soffits, structural slabs, and surfaces supporting weight of concrete. | 14 Days | 17 Days | 21 Days |

END OF SECTION

Part 1 General

1.1 WORK INCLUDED

- .1 The Work included under this section shall conform to the industry standard and be accepted by the local construction and trade associations..

1.2 QUALITY ASSURANCE

- .1 Perform concrete reinforcing Work in accordance with CAN3-A23.1M00 unless specified otherwise in this section.

1.3 SHOP DRAWINGS

- .1 Submit shop drawings and product data to requirements of Section 01300.
- .2 Indicate on shop drawings bar sizes, spacing, locations, and quantities of reinforcing steel, bending and cutting schedules, and supporting and spacing devices.

Part 2 Products

2.1 REINFORCING

- .1 Reinforcing Steel: CSA G30.18M92, 400 yield grade; deformed billet steel bars, plain finish. Welded steel wire fabric: to CSA G30.5-M1983. Provide in flat sheets only.

2.2 ACCESSORY MATERIALS

- .1 Tie Wire: CSA G30.3M, annealed type, or patented system acceptable to Contract Administrator.
- .2 Chairs, Bolsters, Bar Supports, Spacers: size and shaped for strength and support of reinforcing during construction conditions.

2.3 FABRICATION

- .1 Fabricate concrete reinforcing in accordance with ACI 318.1M.
- .2 Locate reinforcing splices, not indicated on drawings, at point of minimum stress. Location of splices subject to review by Contract Administrator.
- .3 Corner bars to extend 36" round corners in both faces.

Part 3 Execution

3.1 PLACEMENT

- .1 Place reinforcing supported and secured against displacement. Do not deviate from true alignment.
- .2 Protect polyethelene moisture vapour under slabs from puncture by placing masonite strips or squares under chairs and other re-bar support devices.
- .3 Before placing concrete, ensure reinforcing is clean, free of loose scale, dirt, or other foreign coatings that would reduce bond to concrete.
- .4 Reinforcing shall have minimum concrete cover as per general notes on drawings.

END OF SECTION

Part 1 General

1.1 WORK INCLUDED

- .1 The Work included under this section shall conform to the industry standard and be accepted by the local construction and trade associations.

1.2 QUALITY ASSURANCE

- .1 Perform cast-in-place concrete Work in accordance with CAN3-A23.1M00 and CAN3-A23.3M94 unless specified otherwise in this Section.
- .2 Conform to CAN3-A266.4M and CSA A266.5M in the use of admixtures.

1.3 TESTS

- .1 Provide analysis and testing of concrete to requirements of Section 01400.
- .2 Test samples in accordance with CAN3-A23.1M00.
- .3 Provide free access to Work and cooperate with appointed firm.
- .4 Submit proposed mix design of each class of concrete to Engineer for review two weeks prior to commencement of Work.
- .5 Tests of cement and aggregates may be performed to ensure conformance with requirements stated herein.
- .6 Three 3 concrete test cylinders will be taken for every 50 cu metres or less of each class of concrete placed.
- .7 One 1 additional test cylinder will be taken during cold weather concreting, and be cured on job site under same conditions as concrete it represents.
- .8 One slump test and one air content test will be taken for each set of test cylinders taken.
- .9 At least three test cylinders will be taken daily for each class of concrete placed.
- .10 Minimum 48 hours of notification to Public Works Building Services Department is required for placing of any concrete Work. All construction Work will be halted if notice is not adhered to.
- .11 Concrete testing to be paid by the City.

Part 2 Products

2.1 CONCRETE MATERIALS

- .1 Cement: CAN/CSA-A5-93 10 and type 50.
- .2 Fine and Coarse Aggregates: CAN3-A23.1M.
- .3 Water: Clean, and free from injurious amounts of oil, alkali, organic matter or other deleterious material harmful to concrete.

2.2 ADMIXTURES

- .1 Air Entrainment: CAN3-A266.1M.

2.3 ACCESSORIES

- .1 Vapour Barrier: 6 mil thick clear polyethylene film, type recommended for below grade application.

2.4 CONCRETE MIXES

- .1 Mix concrete in accordance with ASTM C94.
- .2 Provide concrete to meet the requirements specified in the general notes shown on the drawings.
- .3 Admixtures to be approved by the Contract Administrator. Use of calcium chloride not permitted.

Part 3 Execution

3.1 PLACING CONCRETE

- .1 Place concrete in accordance with CAN3-A23.1M00.
- .2 Notify Contract Administrator and Inspection & Testing Firm minimum 48 hours prior to commencement of concreting operations.
- .3 Ensure anchors, seats, plates, and other items to be cast into concrete are placed, held securely, and will not cause hardship in placing concrete.
- .4 Maintain records of poured concrete items. Record date, location of pour, quantity, air temperature, and test samples taken.
- .5 Ensure reinforcement, inserts, embedded parts, formed expansion and contraction joints are not disturbed during concrete placement.
- .6 Prepare previously placed concrete by cleaning with steel brush and applying bonding agent. Apply bonding agent in accordance with manufacturer's recommendations.
- .7 Pour concrete continuously between predetermined construction and control joints. Do not break or interrupt successive pours to promote cold joints. Visible pour lines in exposed concrete will not be accepted.
- .8 In locations where new concrete is dowelled to existing Work, drill holes in existing concrete, insert steel dowels and pack solidly with non-shrink grout.
- .9 Excessive honeycomb or embedded debris in concrete is not acceptable. Notify Contract Administrator upon discovery.
- .10 Conform to CAN3-A23.1 when concreting during hot weather.
- .11 Conform to CAN3-A23.1 when concreting during cold weather.
- .12 Submit construction sequence indicating construction joints and the pour sequence.
- .13 Install vapor barrier under interior slabs on grade. Lap joints minimum 150 mm and seal with acoustic caulking. Do not disturb or damage vapor barrier while placing concrete reinforcing. If damage occur, repair areas before placing concrete. Use vapor barrier material, lapped over damaged areas minimum 150 mm in direction and seal.
- .14 Separate slabs-on-grade from vertical surfaces with 12mm thick joint filler. Extend joint filler from bottom of slab to within 13mm of finished slab surface. Refer to Section 03100 for joint forming requirements.

3.2 SCREEDING

- .1 Screed floors, slabs-on-fill level, maintaining surface flatness of maximum 2 mm/m. Pitch to drains as shown on the drawings. Maintain slab thickness indicated on drawings at all floor slope areas.

3.3 PATCHING

- .1 Allow Contract Administrator to inspect concrete surfaces immediately upon removal of forms.
- .2 Patch imperfections as directed.

3.4 DEFECTIVE CONCRETE

- .1 Modify or replace concrete not conforming to required lines, details and elevations.
- .2 Repair or replace concrete not properly placed resulting in excessive honeycombing and other defects.
- .3 Do not patch, fill, touch-up, repair, or replace exposed architectural concrete except upon express direction of Contract Administrator for each individual area.

3.5 CONCRETE FINISHING

- .1 Finish concrete to CAN3-A23.3-M94.
- .2 Immediately following stripping of formwork, remove embedded debris, and patch all defective areas and honeycombing, as directed by Contract Administrator.
- .3 Where concrete is to be exposed to view, sandblast very lightly to provide a sand float finish appearance with uniform colour and texture over the entire concrete surface. Confirm desired appearance by testing on a panel of concrete that will be hidden from view. Provide notification so that architect can attend test.
- .4 Rub exposed edges of concrete with a carborundum stone to produce a 3mm radius edge unless otherwise detailed.

3.6 CURING AND PROTECTION

- .1 All concrete shall receive moist curing for a period of at least 72 hours. One of the following methods shall be used as soon as the concrete has hardened sufficiently to prevent marring.
- .2 Surface covered with canvas or other satisfactory material and kept thoroughly wet.
- .3 Surface sealed with polyethylene sheeting at least 0.15 mm thick and the concrete kept thoroughly wet.
- .4 Subject to the approval of the Engineer, a liquid membrane forming, curing compound, applied at a rate recommended by the manufacturer, may be used. Curing compounds shall not be used on the surface where bond is required for additional concrete or toppings.
- .5 Surfaces of concrete which are protected by formwork which is left in place for seven days shall not require any additional curing (except as specified for hot weather). If the formwork is removed in less than seven days, the concrete shall receive a moist curing as above or until seven days have elapsed since the concrete was placed whichever occur first.
- .6 No concreting will be allowed until all materials required for the curing phase are on site and ready for use.
- .7 Wet cure slabs shown to receive liquid hardener, paint, ceramic tile, quarry tile or terrazzo toppings.

END OF SECTION

PART 1 GENERAL

1.1 Related Sections

- .1 Section 04060 - Mortar and Masonry Grout: Mortar, grout and parging.
- .2 Section 04090 - Masonry Accessories.
- .3 Section 04233 – Random Ashlar Limestone.
- .4 Section 05500 - Metal Fabrications: Steel lintels.
- .5 Section 07900 - Joint Sealers: Caulking.

1.2 References

- .1 Canadian Standards Association (CSA)
 - .1 CSA A179-94, Mortar and Grout for Unit Masonry.
 - .2 CSA-A371-94, Masonry Construction for Buildings.

1.3 Samples

- .1 Submit samples in accordance with Section 01330 - Submittal Procedures.
- .2 Submit samples:
 - .1 Two of each type of masonry unit specified.
 - .2 One of each type of masonry accessory specified.
 - .3 One of each type of masonry reinforcement, tie and connector proposed for use.
 - .4 As required for testing purposes.

1.4 Job Mock-Up

- .1 Construct mock-ups in accordance with Section 01450 - Quality Control.
- .2 Construct mock-up panel of exterior masonry wall construction 1200 x 1800 mm showing masonry colours and textures, use of reinforcement, ties, through-wall flashing, weep holes, jointing, coursing, mortar and workmanship.
- .3 Construct mock-up where directed.
- .4 Allow 24 hours for inspection of mock-up by Construction Administrator before proceeding with Work.
- .5 When accepted, mock-up will demonstrate minimum standard for this Work. Mock-up may remain as part of finished Work.

1.5 Delivery, Storage and Handling

- .1 Deliver, store, handle and protect materials in accordance with Section 01610 - Basic Product Requirements.
- .2 Deliver materials to job site in dry condition.
- .3 Keep materials dry until use except where wetting of bricks is specified.
- .4 Store under waterproof cover on pallets or plank platforms held off ground by means of plank or timber skids.

1.6 Waste Management and Disposal

- .1 Separate and recycle waste materials in accordance with Section 01355 - Waste Management and Disposal.
- .2 Collect and separate plastic, paper packaging and corrugated cardboard in accordance with Waste Management Plan.

1.7 Environmental Requirements

- .1 Cold weather requirements
 - .1 Supplement Clause 5.15.2 of CSA-A371 with following requirements:
 - .1 Maintain temperature of mortar between 5°C and 50°C until batch is used.
 - .2 Hot weather requirements
 - .1 Protect freshly laid masonry from drying too rapidly, by means of waterproof, non-staining coverings.
 - .2 Keep masonry dry using waterproof, non-staining coverings that extend over walls and down sides sufficient to protect walls from wind driven rain, until masonry Work is completed and protected by flashings or other permanent construction.
 - .3 Protect masonry and other Work from marking and other damage. Protect completed Work from mortar droppings. Use non-staining coverings.
 - .4 Provide temporary bracing of masonry Work during and after erection until permanent lateral support is in place.

PART 2 PRODUCTS

2.1 Materials

- .1 Masonry materials are specified in Related Sections indicated in 1.1.

PART 3 EXECUTION

3.1 Installation

- .1 Do masonry Work in accordance with CSA-A371 except where specified otherwise.
- .2 Build masonry plumb, level, and true to line, with vertical joints in alignment.
- .3 Layout coursing and bond to achieve correct coursing heights, and continuity of bond above and below openings, with minimum of cutting.

3.2 Construction

- .1 Exposed masonry
 - .1 Remove chipped, cracked, and otherwise damaged units in exposed masonry and replace with undamaged units.
- .2 Jointing
 - .1 Allow joints to set just enough to remove excess water, then tool with round jointer to provide smooth, joints true to line, compressed, uniformly concave joints where concave joints are indicated.
 - .2 Allow joints to set just enough to remove excess water, rake joints uniformly to 6 mm depth and compress with square tool to provide smooth, compressed, raked joints of uniform depth where raked joints are indicated.
 - .3 Strike flush all joints concealed in walls and joints in walls to receive plaster, tile, insulation, or other applied material except paint or similar thin finish coating.
- .3 Cutting
 - .1 Cut out for electrical switches, outlet boxes, and other recessed or built-in objects.
 - .2 Make cuts straight, clean, and free from uneven edges.
- .4 Building-In
 - .1 Build in items required to be built-in into masonry.
 - .2 Prevent displacement of built-in items during construction. Check plumb, location and alignment frequently, as Work progresses.
 - .3 Brace door jambs to maintain plumb. Fill spaces between jambs and masonry with mortar.
- .5 Wetting of bricks
 - .1 Except in cold weather, wet bricks having an initial rate of absorption exceeding 1 g/minute/1000 mm²: wet to uniform degree of saturation, 3 to 24 hours before laying, and do not lay until surface dry.

- .2 Wet tops of walls built of bricks qualifying for wetting, when recommencing Work on such walls.
- .6 Support of loads
 - .1 Use grout to CSA A179 where grout is used in lieu of solid units.
 - .2 Install building paper below voids to be filled with grout; keep paper 25 mm back from faces of units.
- .7 Provision for movement
 - .1 Leave 3 mm space below shelf angles.
 - .2 Leave 6 mm space between top of non-load bearing walls and partitions and structural elements. Do not use wedges.
 - .3 Built masonry to tie in with stabilizers, with provision for vertical movement.
- .8 Loose steel lintels
 - .1 Install loose steel lintels. Centre over opening width.
- .9 Control joints
 - .1 Construct continuous control joints as indicated.
- .10 Expansion joints
 - .1 Build-in continuous expansion joints as indicated.
- .11 Weep Holes
 - .1 Provide weep holes both at first and second rows of masonry veneer, stagger second row from first to allow for unobstructed air circulation.

3.3 Site Tolerances

- .1 Tolerances in notes to Clause 5.3 of CSA-A371 apply.

END OF SECTION

PART 1 GENERAL

1.1 Related Sections

- .1 Section 04051 - Masonry Procedures.
- .2 Section 04090 – Masonry Accessories
- .3 Section 04233 – Random Ashlar Limestone

1.2 References

- .1 Canadian Standards Association (CSA)
 - .1 CSA A179-94, Mortar and Grout for Unit Masonry.

1.3 Samples

- .1 Submit samples in accordance with Section 01330- Submittal Procedures.
- .2 Submit two samples of mortar and coloured mortar.

1.4 Waste Management and Disposal

- .1 Separate and recycle waste materials in accordance with Section 01355 - Waste Management and Disposal.
- .2 Collect and separate plastic, paper packaging and corrugated cardboard in accordance with Waste Management Plan.

PART 2 PRODUCTS

2.1 Materials

- .1 Use same brands of materials and source of aggregate for entire project.
- .2 Mortar and grout: CSA A179.
- .3 Use aggregate passing 1.18 mm sieve where 6 mm thick joints are indicated.
- .4 Colour: ground coloured natural aggregates or metallic oxide pigments.
- .5 Mortar for exterior masonry above grade:
 - .1 Loadbearing: Type N based on Proportion specifications.
 - .2 Non-loadbearing: Type N based on Proportion specifications.
- .6 Following applies regardless of mortar types and uses specified above:
 - .1 Mortar for stonework: Type N based on Proportion specifications.

- .7 Coloured mortar: use colour admixture not exceeding 10% of cement content by mass, or integrally coloured masonry cement, to produce coloured mortar to match approved sample.
- .8 Non-staining mortar: use non-staining masonry cement for cementitious portion of specified mortar type.
- .9 Grout: to CSA A179, Table 3.
- .10 Parging mortar: to CSA A179.

2.2 Mixes

- .1 Colour: Mix grout to semi-fluid consistency.
- .2 Coloured mortars: Incorporate colour into mixes in accordance with manufacturer's instructions.
 - .1 Use clean mixer for coloured mortar.
- .3 Pointing mortar: Pre-hydrate pointing mortar by mixing ingredients dry, then mix again adding just enough water to produce damp unworkable mix that will retain its form when pressed into ball. Allow to stand for not less than 1 hour nor more than 2 hours then remix with sufficient water to produce mortar of proper consistency for pointing.

PART 3 EXECUTION

3.1 Construction

- .1 Do masonry mortar and grout Work in accordance with CSA A179 except where specified otherwise.
- .2 Apply parging in uniform coating not less than total 10 mm thick, where indicated.

3.2 Schedule

- .1 Use coloured mortar for all exterior Work.

END OF SECTION

Part 1 General

1.01 GENERAL REQUIREMENTS

.1 Division One – General Requirements is part of this Section and shall apply as if repeated here.

1.02 WORK INCLUDED

.1 The Work included under this section shall conform to the industry standard and be accepted by the local construction and trade associations.

1.03 RELATED WORK SPECIFIED ELSEWHERE

- .1 Masonry Procedures Section 04051
- .2 Mortar and Masonry Grout Section 04060
- .3 Random Ashlar Limestone Section 04233

Part 2 Products

2.01 MATERIALS

- .1 Control Joint Filler: as specified in Section 07900.
- .2 Masonry Joint Reinforcing/Wall Ties:
 - .1 Exterior Masonry Veneer on wood Stud Backup: Hot dipped galvanized after fabrication conforming to CSA CAN3-A370, BVTS System by FERRO or approved equal.
 - .2 Interior Walls: 9 gauge (3.9mm) truss design mill galvanized finish conforming to ASTM-A641 Class 3 joint reinforcement at all interior masonry walls as manufactured by Dur-O-Wall Ltd. Or Blok-Lok Ltd.
 - .3 Sizes: 2" (50mm) less than wall thickness.
 - .4 Provide prefabricated tees and corners at all locations.
- .3 Reinforcing Bars: to CSA G30.12-M.
- .4 Anchors:
 - .1 Plate type: minimum 3mm galvanized steel, of shapes and sizes to suit purpose.
 - .2 Wire type: 4mm galvanized wire of shapes and sizes shown.
 - .3 Anchor bolts: including nuts, washers, studs, ferrules and related items, galvanized steel as detailed.
- .5 Sheet Membrane Air/Vapour Barrier: as specified in Section 07190
- .6 Cavity Wall Insulation: as specified in Section 07212
- .7 Dovetail Anchor Slots and Ties: Hot dipped galvanized steel dovetail anchor slots with minimum 9 ga. Hot dipped galvanized dovetail triangle ties by Dur-O-Wall Ltd. Or Block-Lok Ltd.
- .8 All Flashings: ASTM A525, Z275 zinc coating; 18 ga core steel, shop pre-coated with 8000 series coating. Flashings are to be formed and installed where the word flashing or metal flashing is indicated on the drawings, to suit flashings above all window and door heads, at low roof high wall, and at metal bellows, closures and water stop locations, etc. Cover top of metal flashing with membrane reinforced flashings at all locations by this section.

- .9 Membrane Reinforced Flashing: "FR-40" by Lexsuco installed with Lexsuco adhesive "CA 106" on all surfaces. Install at all the following locations: base flashing, below window sills, and over top of all metal flashings.
- .10 Building Paper: CSA A123.3M; 15 lb., asphalt saturated felt, or Permax
- .11 Cavity Weep Hole Inserts: CSA A93; galvanized steel or polyvinyl chloride, 10 mm minimum diameter.
- .12 Nailing Inserts: 0.6 mm galvanized steel inserts for setting into mortar joints.
- .13 Bent Metal Closures: 1.2mm (18 ga.) galvanized sheet metal cavity closures of profile shown on drawings.
- .14 Pea Gravel at Cavity Locations: Max. 3/8" dia. Round edge pea gravel with no small fines.

Part 3 Execution

3.01 INSTALLATION OF ACCESSORIES

- .1 Refer to Section 04051 for installation.

END OF SECTION

PART 1 GENERAL

1.1 Related Sections

- .1 Section 00301 Separate Prices
- .2 Section 04051 Masonry Procedures.
- .3 Section 04060 Mortar and Masonry Grout.
- .4 Section 04090 Masonry Accessories.

1.2 References

- .1 CAN3-A165 Series (CAN3-A165.1) (CAN3-A165.3) (CAN3-A165.4)-M85 CSA Standards on Concrete Masonry Units.

PART 2 PRODUCTS

2.1 Materials

- .1 Prefaced concrete block units Type full split face: to CAN3-A165 Series (CAN3-A165.3).
 - .1 Classification of body of unit: H/10/C/M to CAN3-A165.1.
 - .2 Size: modular.
 - .3 Colour: Stone Tone #5-91 Stone as manufactured by Tallcrete or approved equal.

PART 3 EXECUTION

3.1 Installation

- .1 Prefaced concrete block units.
 - .1 Bond: running.
 - .2 Coursing height: 200 mm for one block and one joint.
 - .3 Jointing: provide concave joints.

3.2 Cleaning

- .1 Standard block: Allow mortar droppings on masonry to partially dry then remove by means of trowel, followed by rubbing lightly with small piece of block and finally by brushing.

END OF SECTION

PART 1 GENERAL

1.1 Section Includes

- .1 Work under this section shall include all labour, materials, equipment and services necessary for the completion of all random ashlar limestone Work as shown on the drawings or hereinafter specified.

1.2 Related Sections

- .1 Section 04051 - Masonry Procedures.
- .2 Section 04060 - Mortar and Masonry Grout.
- .3 Section 05500 – Metal Fabrications.
- .4 Section 07900 - Joint Sealers.

1.3 References

- .1 American Concrete Institute (ACI)
 - .1 ACI 530/ASCE 5/TMS 402-98, Building Code Requirements for Masonry Structures.
 - .2 ACI 530.1/ASCE 6/TMS 602-98, Specifications for Masonry Structures.
- .2 American Society for Testing and Materials (ASTM)
 - .1 ASTM A 153/A 153M-98, Standard Specification for Zinc Coated (Hot Dip) on Iron and Steel Hardware.
 - .2 ASTM A 580/A 580M-98 , Standard Specification for Stainless and Heat-Resisting Steel Wire.
 - .3 ASTM C 144-97, Standard Specification for Aggregate for Masonry Mortar.
 - .4 ASTM C 150-97, Standard Specification for Portland Cement.
 - .5 ASTM C 207-91(1997), Standard Specification for Hydrated Lime for Masonry Purposes.
 - .6 ASTM C 270-97, Standard Specification for Mortar for Unit Masonry.
 - .7 ASTM C 780-96, Standard Test Method for Preconstruction and Construction Evaluation of Mortars for Plain and Reinforced Unit Masonry.
- .3 Canadian Standards Association (CSA)
 - .1 CAN/CSA-A5-93, Portland Cement.
 - .2 CSA A179-94: Mortar and Grout for Unit Masonry.
 - .3 CSA A370-94: Connectors for Masonry.

.4 CSA A371-94, Masonry Construction for Buildings.

1.4 Delivery, Storage, and Handling

- .1 Deliver stone promptly in accordance with job schedule requirements. On arrival check all stone for damage and report to carrier and Contract Administrator, noting damage on delivery document. Handle stone carefully. Avoid chipping edges or corners. Store off ground and protect from dirt and damage.
- .2 Store building stone units in a manner designed to prevent damage and staining of units.
- .3 Do not use salt or calcium-chloride to remove ice from masonry surfaces.

1.5 Project / Site Conditions

- .1 Existing conditions – Inspect and arrange for correction of defects or dimension errors in concrete or steel structural surfaces which would affect stone Work..

1.6 Site Environmental Requirements

- .1 Meet or exceed requirements of CSA A371.
 - .1 Maintain mortar temperature between 5 and 50°C until used.
- .2 Maintain materials and surrounding air temperature to minimum 10 °C prior to and 48 hours after completion of masonry Work.
- .3 Cold Weather Requirements: IMI - All Weather Council: Recommended Practices and Specifications for Cold Weather Masonry Construction.

PART 2 PRODUCTS

2.1 Manufacturers

- .1 Acceptable Manufacturers
 - .1 Limestone shall be as quarried and supplied by Gillis Quarries Limited, Winnipeg, Manitoba or approved equal.

2.2 Materials

- .1 Material – Stone shall be Manitoba Tyndall Stone Random Ashlar, a medium density limestone per ASTM C-119 and ASTM C-568.
 - .1 Colour – shall be mixed colour.
 - .2 Grade – shall be standard grade.

2.3 Other materials

- .1 Include other applicable materials such as: water, sand, lime, cement, mortar, water repellent, insulation, caulking, control joints, anchors and ties, reinforcing, supports, flashing, etc.

2.4 Mixes

- .1 Mortar: One (1) part white non-staining cement, one (1) part lime, six (6) parts sand OR one (1) part approved non-staining premixed masonry cement, three (3) parts sand.
- .2 Note: If lump lime is used, paste must be properly aged before use. All mixtures must be used before initial set has taken place – no re-tamping will be permitted. Do not use integral waterproofing.

2.5 Fabrication

- .1 Stone at exterior perimeter base of building:
 - .1 Shop / Factory Finishing: Stone shall be supplied in random lengths (to be further jointed on the job by the setting Contractor as required) and shall be supplied in course heights and wall thickness as follows:
 - .2 Course heights shall be 90mm course height
 - .3 Wall thickness shall be 90mm.
 - .4 Top and Bottom beds shall be: sawn.
 - .5 Ends shall be; sawn.
 - .6 Face finish shall be: split face.
 - .2 Landscape stone at exterior perimeter at grade and along partial walkway as indicated on Sheet A2-1:
 - .1 Random size (non-uniform).
 - .2 Clean of any paint.
 - .3 Minimum mass 45 kg (100 lb) per stone.

PART 3 EXECUTION

3.1 Installation / Application / Erection

- .1 Patterns and Joints - Stone strips shall be laid up in full beds of mortar in a series of continuous single rises or coursings, taking care to build best split face to outside. Stagger vertical joints for balanced appearance; no vertical joint to fall directly over another. All vertical joints to be sawn for best appearance. All joints to be 10mm in width. Mortar in all vertical joints to be packed flush with split stone face. Mortar in all horizontal joints to be tooled concave slightly. Protruding stone end edges to be chipped off on the job by the setting Contractor to create a more continuous coursing, and to achieve a more monolithic appearance to finished wall.

- .2 Colours: Select colours to provide a random blended mixture of buff and grey stones. No less than 35% of wall area to be buff or grey. Care to be taken for balanced distribution of colours.
- .3 Anchoring; Stone to be anchored to back-up wall with metal wall ties as specified spaced not more than 400mm apart vertically and 600mm horizontally (or as called for by local code). All anchors to be corrosion resistant material and to be supplied by the setting Contractor.
- .4 Install Weep holes vents in veneer at 600mm O.C. horizontally maximum at top and bottom of walls.

3.2 Field Quality Control

- .1 After setting, protect projecting areas, corners with boards. Cover walls at night and during rains.

3.3 Adjust and Clean

- .1 Each day brush completed stonework clean with fibre bristle brushes, preferably dry, or with a minimum amount of clean water. Do NOT use wire brushes, acids, or acidic or alkaline cleaning compounds.

3.4 Protection

- .1 Graphitti repellent: refer to Section 09912.

3.5 Tolerances

- .1 Variation in alignment from unit to adjacent unit: 1.5 mm maximum.
- .2 Variation of mortar joint thickness: 3 mm every metre.

3.6 Movement Control Joints

- .1 Do not continue horizontal joint reinforcing across movement control joints.
- .2 Form movement control joints by leaving head joints between stacked units void of mortar, ready for application of bond breaker and joint sealant.

END OF SECTION

Part 1 General

1.01 GENERAL REQUIREMENTS

.1 Division One – General Requirements, is part of this Section and shall apply as if repeated here.

1.02 WORK INCLUDED

.1 The Work included under this section shall conform to the industry standard and be accepted by the local construction and trade associations.

1.03 RELATED WORK SPECIFIED ELSEWHERE

- .1 Masonry Procedures – Section 04051
- .2 Mortar and Masonry Grout – Section 04060
- .3 Masonry Accessories – Section 04090
- .4 Metal Fabrications - Section 05500

1.04 QUALITY ASSURANCE

.1 Installation of Masonry Work: CAN3-A371M, CAN3-S304M.

1.05 SAMPLES

- .1 Submit samples to requirements of Section 01300.
- .2 Submit four samples of coloured masonry units to illustrate colour, texture and extremities of colour range.

1.06 ENVIRONMENTAL REQUIREMENTS

.1 Perform Work to requirements of Section 01561 and Section 04051

Part 2 Products

2.01 CONCRETE MASONRY UNITS

- .1 Hollow Load Bearing Units: CSA A165M, Type H/15/A/M.
- .2 Non-Load Bearing Units: CSA A165M, Type H/15/A/M.
- .3 Solid Load-Bearing Units: CSA A165M, Type S/15/A/M.
- .4 Masonry Units: Standard and single ; face sizes of 190 x 190 mm and 190 x 390 mm x 190 width (refer to drawings). Provide special units for 90-degree corners, bond beams, and lintels.

2.02 SOLID CLAY BRICK UNITS

- .1 TO CAN/CSA A82.1M, as supplied by I-XL Brick Supplies Ltd, Alsips, Ochs Brick or approved equal, and as follows:
 - .1 Type: extruded brick, metric modular size, from stock colors (excluding premium stock colors), texture “graintex”. Specific colour to be chosen after Contract award.
 - .2 Manufactured from one continuous batch to ensure minimum color and texture variations.
 - .3 Solid brick: use where necessary to avoid exposing brick cores.

2.03 ACCESSORIES

- .1 As specified in Section 04090

2.04 LINTELS

- .1 Refer to Structural drawings.

Part 3 Execution

3.01 INSPECTION

- .1 Verify that site conditions are ready to receive Work and dimensions are as indicated on drawings.
- .2 Beginning of installation means acceptance of site conditions.

3.02 PREPARATION

- .1 Verify items provided by other sections of Work are properly sized and located.
- .2 Established lines, levels, and coursing. Protect from disturbance.
- .3 Provide temporary bracing during erection of masonry Work. Maintain in place until building structure provides permanent bracing.

3.03 LAYING

- .1 Face brick – exterior masonry veneer:
 - .1 Bond: running bond.
 - .2 Jointing: concave joints.
- .2 Mixing and blending: mix units within each pallet and with three or more other pallets to ensure uniform blend of color and texture.

3.04 INSTALLATION

- .1 Install masonry units in accordance with Section 04051

3.05 CLEANING

- .1 Test specified cleaning agent and procedures by cleaning a small, designated sample area before start of cleaning.
- .2 Do not proceed with cleaning until sample area is approved.
- .3 Soak wall with clean water and flush off loose dirt and mortar.
- .4 Apply specified cleaning agent in accordance with the manufacturer's direction, working from top to bottom.
- .5 Rinse areas thoroughly with clean water to remove cleaning solutions, dirt, and mortar residue.

END OF SECTION

PART 1 GENERAL

.1 Related Sections

- .1 Section 03300 - Cast-in-Place Concrete: Installation of anchors.
- .2 Section 09911 – Interior Painting.
- .3 Section 09912 – Exterior Painting.

.2 References

- .1 American Society for Testing and Materials (ASTM)
 - .1 ASTM A53/A53M-99b, Specification for Pipe, Steel, Black and Hot-Dipped, Zinc-Coated Welded and Seamless.
 - .2 ASTM A269-98, Specification for Seamless and Welded Austenitic Stainless Steel Tubing for General Service.
 - .3 ASTM A307-97, Specification for Carbon Steel Bolts and Studs, 60,000 PSI Tensile Strength.
- .2 Canadian General Standards Board (CGSB)
 - .1 CAN/CGSB-1.40-97, Anti-corrosive Structural Steel Alkyd Primer.
 - .2 CAN/CGSB-1.108-M89, Bituminous Solvent Type Paint.
 - .3 CAN/CGSB-1.181-92, Ready-Mixed, Organic Zinc-Rich Coating.
- .3 Canadian Standards Association (CSA)
 - .1 CAN/CSA-G40.20/G40.21-98, General Requirements for Rolled or Welded Structural Quality Steel.
 - .2 CAN/CSA-G164-M92(R1998), Hot Dip Galvanizing of Irregularly Shaped Articles.
 - .3 CAN/CSA-S16.1-94, Limit States Design of Steel Structures.
 - .4 CSA W48.1-M1991(R1998), Carbon Steel Covered Electrodes for Shielded Metal Arc Welding.
 - .5 CSA W48.2-M1992(R1998), Chromium-Nickel Steel Covered Electrodes for Shielded.
 - .6 CSA W48.3-M1993(R1998), Low Alloy Steel Covered Electrodes for Shielded Metal Arc Welding.
 - .7 CSA W48.4-95, Solid Carbon Steel Filler Metals for Gas Shielded Arc Welding.
 - .8 CSA W48.5-M1990(R1996), Carbon Steel Electrodes for Flux- and Metal-Cored Arc Welding.
 - .9 CSA W48.6-96, Fluxes and Carbon Steel Electrodes for Submerged Arc Welding.
 - .10 CSA W59-M1998, Welded Steel Construction (Metal Arc Welding).

.3 Shop Drawings

- .1 Submit shop drawings in accordance with Section 01330 - Submittal Procedures.

- .2 Indicate materials, core thicknesses, finishes, connections, joints, method of anchorage, number of anchors, supports, reinforcement, details, and accessories.
- .3 Shop drawings must be sealed and signed by a structural engineer registered in the province of the Work.

.4 Protection

- .1 Deliver, store, handle and protect materials in accordance with Section 01610 - Basic Product Requirements.
- .2 Cover exposed stainless steel surfaces with pressure sensitive heavy protection paper or apply strippable plastic coating, before shipping to job site.
- .3 Leave protective covering in place until final cleaning of building. Provide instructions for removal of protective covering.

PART 2 PRODUCTS

.1 Materials

- .1 Steel sections and plates: to CAN/CSA-G40.20/G40.21, Grade 350 W.
- .2 Steel pipe: to ASTM A53/A53M standard weight black finish.
- .3 Welding materials: to CSA W59.
- .4 Welding electrodes: to CSA W48 Series.
- .5 Bolts and anchorbolts: to ASTM A307.
- .6 Grout: non-shrink, non-metallic, flowable, 15 MPa at 24 hours.

.2 Fabrication

- .1 Fabricate Work square, true, straight and accurate to required size, with joints closely fitted and properly secured.
- .2 Use self-tapping shake-proof round headed screws on items requiring assembly by screws or as indicated.
- .3 Where possible, fit and shop assemble Work, ready for erection.
- .4 Ensure exposed welds are continuous for length of each joint. File or grind exposed welds smooth and flush.

.3 Finishes

- .1 Galvanizing: hot dipped galvanizing with zinc coating 600 g/m² to CAN/CSA-G164.
- .2 Shop coat primer: to CAN/CGSB-1.40.
- .3 Zinc primer: zinc rich, ready mix to CAN/CGSB-1.181.

- .4 Bituminous paint: to CAN/CGSB-1.108.

.4 Isolation Coating

- .1 Isolate Aluminum from following components, by means of bituminous paint:
 - .1 Dissimilar metals except stainless steel, zinc, or white bronze of small area.
 - .2 Concrete, mortar and masonry.
 - .3 Wood.

.5 Shop Painting

- .1 Apply one shop coat of primer to metal items, with exception of galvanized or concrete encased items.
- .2 Use primer unadulterated, as prepared by manufacturer. Paint on dry surfaces, free from rust, scale and grease. Do not paint when temperature is lower than 7°C.
- .3 Clean surfaces to be field welded; do not paint.

.6 Angle Lintels

- .1 Steel angles: galvanized, sizes indicated for openings. Provide 150 mm minimum bearing at ends.
- .2 Weld or bolt back-to-back angles to profiles as indicated.
- .3 Finish: shop painted.

.7 Pipe Railings

- .1 Steel pipe: 40 mm nominal outside diameter, formed to shapes and sizes as indicated.
- .2 Galvanize exterior pipe railings after fabrication. Shop coat prime interior railings after fabrication.

.8 Counter and Bench Supports

- .1 Support: dimensions as detailed, steel angle. Prime paint for interior.

.9 Shelf Brackets

- .1 Fabricate frames from steel, sizes as shown on drawings.

.10 Ice Flooding Hose Wall Brackets

- .1 Fabricate or purchase steel U-shaped brackets capable of supporting 45 meters of 25mm black rubber hose.
- .2 Finish: prime coat, painted, or pre-finished purchased stock items.

PART 3 EXECUTION

.1 Erection

- .1 Do welding Work in accordance with CSA W59 unless specified otherwise.
- .2 Erect metalwork square, plumb, straight, and true, accurately fitted, with tight joints and intersections.
- .3 Provide suitable means of anchorage acceptable to Contract Administrator such as dowels, anchor clips, bar anchors, expansion bolts and shields, and toggles.
- .4 Exposed fastening devices to match finish and be compatible with material through which they pass.
- .5 Supply components for building into Work by other sections in accordance with shop drawings and schedule.
- .6 Make field connections with bolts to CAN/CSA-S16.1, or weld.
- .7 Hand items over for casting into concrete or building into masonry to appropriate trades together with setting templates.
- .8 Touch-up rivets, field welds, bolts and burnt or scratched surfaces after completion of erection with primer.
- .9 Touch-up galvanized surfaces with zinc rich primer where burned by field welding.

.2 Pipe Railings

- .1 Install all pipe railings to stairs as drawn.

.3 Shelf Brackets

- .1 Install brackets as indicated.

.4 Hose Brackets

- .1 Supply quantity as indicated. Install with adequate backing to support hose specified.

END OF SECTION

PART 1 GENERAL

1.1 Related Sections

1.2 References

- .1 American National Standards Institute (ANSI)
 - .1 ANSI A208.1-1999, Particleboard, Mat Formed Wood.
- .2 American Society for Testing and Materials (ASTM)
 - .1 ASTM A 36/A 36M-94, Specification for Structural Steel.
 - .2 ASTM A 653/A 653M-94, Specification for Sheet Steel, Zinc-Coated (Galvanized) or Zinc-Iron Alloy-Coated (Galvanealed) by the Hot Dip Process.
 - .3 ASTM D 1761-88, Standard Test Methods for Mechanical Fasteners in Wood.
 - .4 ASTM D 5055-94a, Prefabricated Wood I-Joists.
 - .5 ASTM D 5456-96, Evaluation of Structural Composite Lumber Products.
- .3 Canadian General Standards Board (CGSB)
 - .1 CAN/CGSB-11.3-M87, Hardboard.
 - .2 CAN/CGSB-51.32-M77, Sheathing, Membrane, Breather Type.
 - .3 CAN/CGSB-51.34-M86, Vapour Barrier, Polyethylene Sheet for Use in Building Construction.
 - .4 CAN/CGSB-71.26-M88, Adhesive for Field-Gluing Plywood to Lumber Framing for Floor Systems.
- .4 Canadian Standards Association (CSA)
 - .1 CAN/CSA-A82.27-M91, Gypsum Board.
 - .2 CSA-B111-1974, Wire Nails, Spikes and Staples.
 - .3 CAN/CSA-G164-M92, Hot Dip Galvanizing of Irregularly Shaped Articles.
 - .4 CSA-O112 Series-M1977, CSA Standards for Wood Adhesives.
 - .5 CSA O121-M1978, Douglas Fir Plywood.
 - .6 CAN/CSA-O122-M89, Structural Glued-Laminated Timber.
 - .7 CAN/CSA-O141-91, Softwood Lumber.
 - .8 CSA-O151-M1978, Canadian Softwood Plywood.
 - .9 CSA-O153-M1980, Poplar Plywood.
 - .10 CAN/CSA-O325.0-92, Construction Sheathing.
 - .11 CAN3-O437 Series-93, Standards on OSB and Waferboard.

- .5 National Lumber Grades Authority (NLGA)
 - .1 Standard Grading Rules for Canadian Lumber 1991.
- .6 'Truss Design and Procedures for Light Metal Connected Wood Trusses', Truss Plate Institute of Canada

1.3 Quality Assurance

- .1 Lumber identification: by grade stamp of an agency certified by Canadian Lumber Standards Accreditation Board.
- .2 Plywood, particleboard, OSB and wood based composite panels in accordance with CSA and ANSI standards.

1.4 Waste Management and Disposal

- .1 Set aside damaged wood and dimensional lumber off-cuts for approved alternative uses (e.g. bracing, blocking, cripples, bridging). Store this separated reusable wood waste convenient to cutting station and area of Work.
- .2 Separate metal, plastic, wood and corrugated cardboard packaging in accordance with the Waste Management Plan and place in designated areas for recycling.
- .3 Do not burn scrap at the project site.
- .4 Fold up metal banding, flatten, and place in designated area for recycling.

PART 2 PRODUCTS

2.1 Framing and Structural Materials

- .1 Lumber: unless specified otherwise, softwood, S4S, moisture content 19% (S-dry) or less in accordance with following standards:
 - .1 CAN/CSA-O141.
 - .2 NLGA Standard Grading Rules for Canadian Lumber.
- .2 Glued end-jointed (finger-jointed) lumber NLGA Special Products Standard.
- .3 Glulam in accordance with Structural Glued-Laminated Timber CAN/CSA-O122.
- .4 Wood I-joists in accordance with Prefabricated Wood I-Joists ASTM D 5055.
- .5 Light-frame trusses in accordance with "Truss Design and Procedures for Light Metal Connected Wood Trusses", Truss Plate Institute of Canada.
- .6 Structural Composite Lumber (SCL) in accordance with Evaluation of Structural Composite Lumber Products ASTM D 5456.

- .7 Framing and board lumber: in accordance with NBC and drawings, except as follows:
- .8 Furring, nailing strips, grounds, rough bucks, cants, curbs, fascia backing and sleepers:
 - .1 Board sizes: "Standard" or better grade.
 - .2 Dimension sizes: "Standard" light framing or better grade.
 - .3 Post and timbers sizes: "Standard" or better grade.
- .9 Timber beams and columns. Refer to Section 01110 Summary of Work – Items supplied by City, refurbished and installed by Contractor.

2.2 Panel Materials

- .1 Plywood, OSB and wood based composite panels: to CAN/CSA-O325.0.
- .2 Douglas fir plywood (DFP): to CSA-O121, standard construction.
- .3 Canadian softwood plywood (CSP): to CSA-O151, standard construction.
- .4 Poplar plywood (PP): to CSA-O153, standard construction.
- .5 Interior mat-formed wood particleboard: to ANSI 208.1.
- .6 Mat-formed structural panelboards (OSB wafer): to CAN3-O437.0.
- .7 Insulating fiberboard sheathing: to CAN/CSA-A247.
- .8 Glass fibre board sheathing: non-structural, rigid, faced, fiberglass, insulating exterior sheathing board.
- .9 Gypsum sheathing: to CSA-A82.27.

2.3 Accessories

- .1 Exterior wall sheathing paper: to CAN/CGSB-51.32 laminated type as indicated.
- .2 Polyethylene film: as indicated.
- .3 Air seal: closed cell polyurethane or polyethylene.
- .4 Sealants: as indicated.
- .5 Subflooring adhesive: to CGSB-71.26, cartridge loaded.
- .6 General purpose adhesive: to CSA-O112 Series.
- .7 Nails, spikes and staples: to CSA-B111.

- .8 Joist hangers: minimum 1 mm thick sheet steel, galvanized ZF001 coating designation.
- .9 Roof sheathing H-Clips: formed "H" shape, thickness to suit panel material, type approved by Contract Administrator.

2.4 Fastener Finishes

- .1 Galvanizing: to CAN/CSA-G164, use hot-dipped galvanized fasteners for exterior Work, interior highly humid areas, pressure-preservative, fire-retardant, treated lumber.

2.5 Wood Preservative

- .1 ACQ or Borate treated lumber only. No chromium or arsenic allowed, including CCA or ACA treated wood.

PART 3 EXECUTION

3.1 Preparation

- .1 Store wood products.

3.2 Installation

- .1 Comply with requirements of NBC 1995 Part 9 supplemented by following paragraphs.
- .2 Install members true to line, levels and elevations, square and plumb.
- .3 Construct continuous members from pieces of longest practical length.
- .4 Install spanning members with "crown-edge" up.
- .5 Select exposed framing for appearance. Install lumber and panel materials so that grade-marks and other defacing marks are concealed or are removed by sanding where materials are left exposed.
- .6 Install subflooring with panel end-joints located on solid bearing, staggered at least 600 mm.
 - .1 In addition to mechanical fasteners, floor panels secure floor subflooring to floor joists using glue and screws. Place continuous adhesive bead in accordance with manufacturer's instructions, single-bead on each joist and double-bead on joists where panel ends butt.
- .7 Install wall sheathing in accordance with manufacturer's printed instructions.
- .8 Install roof sheathing in accordance with requirements of NBC.

- .9 Install furring and blocking as required to space-out and support casework, cabinets, wall and ceiling finishes, facings, fascia, soffit, siding, electrical equipment mounting boards, and other Work as required.
- .10 Install furring to support siding applied vertically where there is no blocking and where sheathing is not suitable for direct nailing.
 - .1 Align and plumb faces of furring and blocking to tolerance of 1:600.
- .11 Install rough bucks, nailers and linings to rough openings as required to provide backing for frames and other Work.
- .12 Install wood cants, fascia backing, nailers, curbs and other wood supports as required and secure using galvanized fasteners.
- .13 Install sleepers as indicated.
- .14 Use caution when working with particle board. Use dust collectors and high quality respirator masks.

3.3 Erection

- .1 Frame, anchor, fasten, tie and brace members to provide necessary strength and rigidity.
- .2 Countersink bolts where necessary to provide clearance for other Work.
- .3 Use nailing disks for soft sheathing as recommended by sheathing manufacturer.

3.4 Schedules

- .1 Refer to drawings.

END OF SECTION

PART 1 GENERAL

1.1 Related Sections

- .1 Section 01330 - Submittal Procedures.
- .2 Section 01610 - Basic Product Requirements.

1.2 References

- .1 Canadian Standards Association (CSA)
 - .1 CAN/CSA-O80 Series-97, Wood Preservation.
 - .2 CAN/CSA-O86.1-94, Engineering Design in Wood (Limit States Design).
 - .3 CAN/CSA-O141-91(R1999), Softwood Lumber.
 - .4 CSA S307-M1980(R2001), Load Test Procedure for Wood Roof Trusses for Houses and Small Buildings.
 - .5 CSA S347-99, Method of Test for Evaluation of Truss Plates Used in Lumber Joints.
 - .6 CSA W47.1-92(R1998), Certification of Companies for Fusion Welding of Steel Structures.
- .2 National Lumber Grades Authority (NLGA)
 - .1 NLGA-2000, Standard Grading Rules for Canadian Lumber.

1.3 Design Criteria

- .1 Design trusses, bracing and bridging in accordance with CAN/CSA-O86.1 for loads indicated, for building locality as ascertained by NBC, Climatic Information for Building Design in Canada, and minimum uniform and minimum concentrated loadings stipulated in NBC commentary.
- .2 Limit live load deflection to 1/360th of span unless otherwise specified or indicated.
- .3 Provide camber for trusses as indicated.

1.4 Source Quality Control

- .1 Identify lumber by grade stamp of an agency certified by Canadian Lumber Standards Administration Board.

1.5 Qualification of Manufacturers

- .1 Fabricator for welded steel connections to be certified in accordance with CSA W47.1.

1.6 Shop Drawings

- .1 Submit shop drawings in accordance with Section 01330 - Submittal Procedures.
- .2 Each shop and erection drawing submission shall bear signature and stamp of professional engineer registered or licensed in province of the Work.
- .3 Indicate species, sizes, and stress grades of lumber used as truss members. Show pitch, span, camber, configuration and spacing of trusses. Indicate connector types, thicknesses, sizes, locations and design value. Show bearing details. Indicate design load for members.
- .4 Submit stress diagram or print-out of computer design indicating design load for truss members. Indicate allowable load and stress increase.
- .5 Indicate arrangement of webs or other members to accommodate ducts and other specialties.
- .6 Show lifting points for storage, handling and erection.
- .7 Show location of lateral bracing for compression members.

1.7 Delivery and Storage

- .1 Deliver, handle, store and protect materials in accordance with Section 01610 - Basic Product Requirements.
- .2 Store trusses on job site in accordance with manufacturer's instructions. Provide bearing supports and bracings. Prevent bending, warping and overturning of trusses.

1.8 Waste Management and Disposal

- .1 Separate and recycle waste materials in accordance with Section 01355 - Waste Management and Disposal.
- .2 Collect and separate plastic, paper packaging and corrugated cardboard in accordance with Waste Management Plan
- .3 Fold up metal banding, flatten and place in a designated area for recycling.

PART 2 PRODUCTS

2.1 Materials

- .1 Lumber: SPF species, #2 grade, softwood, S4S, with maximum moisture content of 19% at time of fabrication and to following standards:
 - .1 CAN/CSA-O141.

.2 NLGA (National Lumber Grading Association), Standard Grading Rules for Canadian Lumber.

.2 Fastenings: to CAN/CSA-O86.1.

2.2 Fabrication

.1 Fabricate wood trusses in accordance with reviewed shop drawings.

.2 Provide for design camber and roof slopes when positioning truss members.

.3 Connect members using metal connector plates.

PART 3 EXECUTION

3.1 Erection

.1 Erect wood trusses in accordance with reviewed erection drawings.

.2 Indicated lifting points to be used to hoist trusses into position.

.3 Make adequate provisions for handling and erection stresses.

.4 Exercise care to prevent out-of-plane bending of trusses.

.5 Install temporary horizontal and cross bracing to hold trusses plumb and in safe condition until permanent bracing and decking are installed.

.6 Install permanent bracing in accordance with reviewed shop drawings, prior to application of loads to trusses.

.7 Do not cut or remove any truss material without approval of Contract Administrator.

END OF SECTION

PART 1 GENERAL

1.1 Related Sections

- .1 Section 06400 - Architectural Woodwork: Architectural Woodwork.
- .2 Section 06666 - Plastic Laminates: Laminated plastic Work.
- .3 Section 09911 - Interior Painting: Painting and finishing.

1.2 References

- .1 American National Standards Institute (ANSI)
 - .1 ANSI A208.1-1989, Particleboard, Matformed Wood.
 - .2 ANSI A208.2-1994, Medium Density Fibreboard (MDF).
- .2 Architectural Woodwork Manufacturers Association of Canada (AWMAC)
 - .1 AWMAC Quality Standards for Architectural Woodwork 2003.
- .3 Canadian General Standards Board (CGSB)
 - .1 CAN/CGSB-11.3-M87, Hardboard.
- .4 Canadian Standards Association (CSA)
 - .1 CSA B111-1974, Wire Nails, Spikes and Staples.
 - .2 CAN/CSA-G164-M92, Hot Dip Galvanizing of Irregularly Shaped Articles.
 - .3 CSA O115-M1982, Hardwood and Decorative Plywood.
 - .4 CSA O121-M1978, Douglas Fir Plywood.
 - .5 CAN/CSA O141-91, Softwood Lumber.
 - .6 CSA O151-M1978, Canadian Softwood Plywood.
 - .7 CSA O153-M1980, Poplar Plywood.
- .5 National Hardwood Lumber Association (NHLA)
 - .1 Rules for the Measurement and Inspection of Hardwood and Cypress
January 1986.
- .6 National Lumber Grades Authority (NLGA)
 - .1 Standard Grading Rules for Canadian Lumber 1996.
- .7 Underwriters Laboratories of Canada (ULC)
 - .1 CAN4-S104-M80(R1985), Fire Tests of Door Assemblies.
 - .2 CAN4-S105-M85, Fire Door Frames.

1.3 Shop Drawings

- .1 Submit shop drawings in accordance with Section 01330 - Submittal Procedures.
- .2 Indicate details of construction, profiles, jointing, fastening and other related details.
- .3 Indicate all materials, thicknesses, finishes and hardware.

1.4 Samples

- .1 Submit samples in accordance with Section 01330 - Submittal Procedures.

1.5 Regulatory Requirements

- .1 Wood fire rated frames and panels: listed and labelled by an organization accredited by Standards Council of Canada in conformance with CAN4-S104M and CAN4-S105M for ratings specified or indicated.

1.6 Delivery, Storage, and Handling

- .1 Deliver, handle, store and protect materials in accordance with Section 01610 - Basic Product Requirements.
- .2 Protect materials against dampness during and after delivery.
- .3 Store materials in ventilated areas, protected from extreme changes of temperature or humidity.

1.7 Waste Management and Disposal

- .1 Separate and recycle waste materials in accordance with Section 01355 - Waste Management and Disposal and Waste Reduction Workplan, and Waste Management plan to maximum extent economically possible.
- .2 Separate wood waste in accordance with the Waste Management Plan and place in designated areas in categories as follows for recycling: Solid wood/softwood/hardwood, and composite wood.
- .3 Separate wood waste in accordance with the Waste Management Plan and place in designated areas in categories as follows for re-use on site: sheet materials larger than 600 x 600mm, framing members larger than 900mm.
- .4 Set aside damaged wood for acceptable alternative uses (e.g. bracing, blocking, cripples, bridging, finger-jointing, or ties). Store this separated reusable wood waste convenient to cutting station and area of Work.
- .5 Separate corrugated cardboard in accordance with Waste Management Plan and place in designated areas for recycling.
- .6 Do not burn scrap at project site.

- .7 Fold up metal banding, flatten, and place in designated area for recycling.

PART 2 PRODUCTS

2.1 Lumber Material

- .1 Softwood lumber: unless specified otherwise, S4S, moisture content 19% or less in accordance with following standards:
 - .1 CAN/CSA O141.
 - .2 NLGA Standard Grading Rules for Canadian Lumber.
 - .3 AWMAC custom grade, moisture content as specified.
- .2 Machine stress-rated lumber is acceptable for all purposes.
- .3 Hardwood lumber: moisture content 6 % or less in accordance with following standards:
 - .1 National Hardwood Lumber Association (NHLA).
 - .2 AWMAC custom grade, moisture content as specified.
- .4 Manufacturing process must adhere to Lifecycle Assessment (LCA) Standards as per ISO 14040/14041 LCA Standards.
- .5 Reclaimed timber: Refer to Section 01110 Summary of Work – City Supplied Items.
- .6 Wood soffits where indicated: Western Red Cedar – clear.

2.2 Panel Material

- .1 Douglas fir plywood (DFP): to CSA O121, standard construction.
- .2 Canadian softwood plywood (CSP): to CSA O151, standard construction.
- .3 Hardwood plywood: to CSA O115.
- .4 Poplar plywood (PP): to CSA O153, standard construction.
- .5 Particleboard: to ANSI A208.1-99.
- .7 Wall panels: (In rooms 110 Gym, 104 Multipurpose Room, and all Dressing Rooms and General Lobby, Corridor and Skate Change) Woodstalk Gold grade 13mm thick, for finishing refer to Section 09911.
- .8 Hardboard: to CAN/CGSB-11.3.
 - .1 Hardboard must be manufactured such that formaldehyde emissions do not exceed 0.05 ppm 180 g/m³ when tested in accordance with ASTM E 1333, Standard Test Method for Determining Formaldehyde Levels

From Wood Products Under Defined Test Conditions Using a Large Chamber;

- .9 Low density fibreboard: to CAN3-A247M.
 - .1 Ensure fibreboard is not manufactured with binders, coatings or adhesives which contain resins or other compounds that have potential to release formaldehyde during final product's use;
- .10 Manufacturing process must adhere to Lifecycle Assessment Standards as ISO 14040/14041 LCA Standards

2.3 Accessories

- .1 Nails and staples: to CSA B111; galvanized to CAN/CSA-G164 for exterior Work, interior humid areas and for treated lumber; plain finish elsewhere.
- .2 Wood screws: to CSA B35.4 plain, type and size to suit application.
- .3 Splines: wood.
- .4 Adhesive: recommended by manufacturer such that formaldehyde emissions do not exceed 0.05 ppm 180 g/m³.
- .5 Use least toxic sealants, adhesives, sealers, and finishes necessary to comply with requirements of this section.

PART 3 EXECUTION

3.1 Installation

- .1 Do finish carpentry to Quality Standards of the Architectural Woodwork Manufacturers Association of Canada (AWMAC), except where specified otherwise.
- .2 Scribe and cut as required, fit to abutting walls, and surfaces, fit properly into recesses and to accommodate piping, columns, fixtures, outlets, or other projecting, intersecting or penetrating objects.
- .3 Form joints to conceal shrinkage.

3.2 Construction

- .1 Fastening.
 - .1 Position items of finished carpentry Work accurately, level, plumb, true and fasten or anchor securely.
 - .2 Design and select fasteners to suit size and nature of components being joined. Use proprietary devices as recommended by manufacturer.

- .3 Set finishing nails to receive filler. Where screws are used to secure members, countersink screw in round cleanly cut hole and plug with wood plug to match material being secured.
- .4 Replace items of finish carpentry with damage to wood surfaces including hammer and other bruises.
- .2 Standing and running trim.
 - .1 Butt and cope internal joints of baseboards to make snug, tight, joint. Cut right angle joints of casing and base with mitred joints.
 - .2 Fit backs of baseboards and casing snugly to wall surfaces to eliminate cracks at junction of base and casing with walls.
 - .3 Make joints in baseboard, where necessary using a 45° scarf type joint.
 - .4 Install door and window trim in single lengths without splicing.
- .3 Interior and exterior frames.
 - .1 Set frames with plumb sides and level heads and sills and secure.
- .4 Panelling.
 - .1 Secure panelling and perimeter trim using adhesive recommended for purpose by manufacturer. Fill nail holes caused by temporary fixing with filler matching wood in colour.
- .5 Stairs.
 - .1 Install stairs to location and details as indicated.
- .6 Handrails.
 - .1 Support brackets will be supplied under Section 05500 for installation under this Section.
 - .2 Install brackets at ends and at 1200 mm O.C. maximum at intermediate spacings.
 - .3 Install metal backing plates between studs at bracket locations to ensure proper support for brackets and bolts or self-tapping screws.
- .7 Shelving.
 - .1 Install shelving on shelf brackets.
- .8 Hardware.
 - .1 Verify that door and frame components are ready to receive Work and dimensions are as indicated on shop drawings.
 - .2 Verify that appropriate power supply is available to power operated devices.
 - .3 Beginning of installation means acceptance of existing conditions.

- .4 Install hardware in accordance with manufacture's instructions and requirements of Canadian Steel Door and Frame Manufacturers Association.
- .5 Use the templates provided by hardware item manufacturer.
- .9 Wood Doors.
 - .1 Install doors in accordance with manufacturer's instructions.
 - .2 Machine cut relief for hinges and coring for handsets and cylinders.
 - .3 Trim door width by cutting equally on both jambs. Trim fire door width from lock edge only, to a maximum of 5mm.
 - .4 Trim door height by cutting equally on top and bottom edges to a maximum of 19mm. Trim fire door height at bottom edge only, to a maximum of 15mm.
 - .5 Undercut doors to a maximum of 6mm above finished floor.
 - .6 Prepare doors to receive finish hardware in accordance with AWMAC requirements.
 - .7 Conform to AWMAC requirements for fit tolerances. Maximum diagonal distortions: 1.5mm measured with straight edge, corner to corner.
 - .8 Coordinate installation of glass and glazing. Install door louvers, as called for on Door schedule or on Mechanical Drawings.

END OF SECTION

PART 1 GENERAL

1.1 Related Sections

- .1 Section 06666 - Plastic Laminates.
- .2 Section 07900 - Joint Sealers.

1.2 References

- .1 American Society for Testing and Materials (ASTM)
 - .1 ASTM E 1333- 90 , Standard Test Method for Determining Formaldehyde Levels From Wood Products Under Defined Test Conditions Using a Large Chamber.
- .2 Architectural Woodwork Manufacturers Association of Canada (AWMAC)
 - .1 AWMAC Quality Standards for Architectural Woodwork 2003.
- .3 Canadian Standards Association (CSA)
 - .1 CAN3-A172- M79, High Pressure Paper Base, Decorative Laminates.
 - .2 CSA B111- 1974, Wire Nails, Spikes and Staples.
 - .3 CSA O115- M1982, Hardwood and Decorative Plywood.
 - .4 CSA O121- M1978, Douglas Fir Plywood.
 - .5 CAN/CSA O141- 91, Softwood Lumber.
 - .6 CSA O151- M1978, Canadian Softwood Plywood.
 - .7 CSA O153- M1980, Poplar Plywood.
 - .8 CAN/CGSB-11.3- M87, Hardboard.
- .4 National Hardwood Lumber Association (NHLA)
 - .1 Rules for the Measurement and Inspection of Hardwood and Cypress January 1996.
- .5 National Lumber Grades Authority (NLGA)
 - .1 Standard Grading Rules for Canadian Lumber 1991.

1.3 Shop Drawings

- .1 Submit shop drawings in accordance with Section 01330 - Submittal Procedures.
- .2 Indicate details of construction, profiles, jointing, fastening and other related details.
 - .1 Scale: profiles, details 1/2 full size.
- .3 Indicate all materials, thicknesses, finishes and hardware.

- .4 Indicate locations of all service outlets in casework, typical and special installation conditions, and all connections, attachments, anchorage and location of exposed fastenings.

1.4 Quality Assurance

- .1 Perform Work in accordance with Custom Grade quality.
- .2 Work in this Section shall comply with the specified Grade of Work and Sections of the current edition of the AWI/AWMAC Quality Standard Illustrated.

1.5 Qualifications

- .1 Contractors and their personnel engaged in the Work shall be able to demonstrate successful experience with Work of comparable extent, complexity and quality to that shown and specified.
- .2 Manufacturers who are members in good standing of the Architectural Woodwork Institute (AWI) or the Architectural Woodwork Manufacturers Association of Canada (AWMAC) and are familiar with this Standard.

1.6 Delivery, Storage, and Handling

- .1 Deliver, handle, store and protect materials of this section in accordance with Section 01610 - Basic Product Requirements.
- .2 Protect millwork against dampness and damage during and after delivery.
- .3 Store millwork in ventilated areas, protected from extreme changes of temperature or humidity.

1.7 Waste Management and Disposal

- .1 Separate and recycle waste materials in accordance with Section 01355 - Waste Management and Disposal and the Waste Reduction Workplan, and the Waste Management plan to the maximum extent economically possible.
- .2 Separate wood waste in accordance with the Waste Management Plan and place in designated areas in the following categories for recycling: Solid wood/softwood/hardwood, composite wood.
- .3 Separate wood waste in accordance with the Waste Management Plan and place in designated areas in the following categories for re-use on site: sheet materials larger than 600 x 600mm, framing members larger than 900mm.
- .4 Set aside damaged wood for acceptable alternative uses (e.g. bracing, blocking, cripples, bridging, finger-joining, or ties). Store this separated reusable wood waste convenient to cutting station and area of Work.

- .5 Separate corrugated cardboard in accordance with the Waste Management Plan and place in designated areas for recycling.
- .6 Do not burn scrap at the project site.
- .7 Fold up metal banding, flatten, and place in designated area for recycling.

PART 2 PRODUCTS

2.1 Materials

- .1 Softwood lumber: unless specified otherwise, S4S, moisture content 15 % or less in accordance with following standards:
 - .1 CAN/CSA O141.
 - .2 NLGA Standard Grading Rules for Canadian Lumber.
 - .3 AWMAC custom grade, moisture content as specified.
- .2 Machine stress-rated lumber is acceptable for all purposes.
- .3 Hardwood lumber: moisture content 7 % or less in accordance with following standards:
 - .1 National Hardwood Lumber Association (NHLA).
 - .2 AWMAC custom grade, moisture content as specified.
- .4 Douglas fir plywood (DFP): to CSA O121, standard construction.
- .5 Canadian softwood plywood (CSP): to CSA O151, standard construction.
- .6 Hardwood plywood: to CSA O115.
- .7 Poplar plywood (PP): to CSA O153, standard construction.
- .8 Hardboard
 - .1 to CAN/CGSB-11.3.
 - .2 manufactured such that formaldehyde emissions do not exceed 0.15 ppm (180 g/m³) when tested in accordance with ASTM E 1333.
 - .3 if manufactured using a wet process:
 - .1 be made by a process that does not release matter in the undiluted product plant effluent generating a BOD 5 in excess of 50 mg/L to a natural watercourse or a sewage treatment facility lacking secondary treatment;
 - .2 be made by a process that does not release TSS in excess of 60 mg/L to a natural watercourse or a sewage treatment facility lacking secondary treatment;
 - .4 contain at least 50 % recycled materials if available.

- .9 Melamine: to CAN3-0188.1 Grade R; density 720 kg/m³. Melamine finish to NEMA LQ1, minimum 120 gram weight, thermally fired both sides to both sides of Woodstark. Color: White.
- .10 Nails and staples: to CSA B111.
- .11 Wood screws: steel, type and size to suit application.
- .12 Splines: wood, plastic, or metal.
- .13 Door and drawer pulls: 96mm "flared" pulls – satin brass finish.
- .14 Sealant: in accordance with 07900 Joint Sealers .
- .15 The manufacturing process must adhere to Lifecycle Assessment (LCA) Standards as per ISO 14040/14041 LCA Standards.

2.2 Manufactured Units

- .1 Casework.
 - .1 Fabricate caseworks to AWMAC custom quality grade.
 - .2 Furring, blocking, nailing strips, grounds and rough bucks and sleepers.
 - .1 S2S is acceptable.
 - .2 Board sizes: "Standard" or better grade.
 - .3 Dimension sizes: "Standard" light framing or better grade.
 - .3 Framing SPF species, NLGA #1 grade, para.
 - .4 Case bodies (ends, divisions and bottoms).
 - .1 Particleboard, square edge, 19mm thick, white melamine finish.
 - .5 Backs.
 - .1 Particleboard, square edge, 13mm thick, white melamine finish.
 - .6 Shelving.
 - .1 Particleboard, square edge, 16mm thick, white melamine finish.
- .2 Drawers
 - .1 Fabricate drawers to AWMAC custom grade supplemented as follows:
 - .2 Sides and Backs.
 - .1 Particleboard, square edge, 19mm thick, white melamine finish.
 - .3 Bottoms.
 - .1 Particleboard, square edge, 19mm thick, white melamine finish.
 - .4 Fronts.

- .1 Particleboard, 19mm thick, thermofoil finish with "Natural" color "Sommerset" style.

- .3 Casework Doors

- .1 Fabricate doors to AWMAC custom grade supplemented as follows:
- .2 Particleboard, 19mm thick, thermofoil finish with "Natural" color "Sommerset" style.

2.3 Fabrication

- .1 Set nails and countersink screws, apply plain wood filler to indentations, sand smooth and leave ready to receive finish.
- .2 Shop install cabinet hardware for doors, shelves and drawers. Recess shelf standards unless noted otherwise.
- .3 Shelving to cabinetwork to be adjustable unless otherwise noted.
- .4 Provide cutouts for plumbing fixtures, inserts, appliances, outlet boxes and other fixtures.
- .5 Shop assemble Work for delivery to site in size easily handled and to ensure passage through building openings.

2.4 Finishing

- .1 Sand Work smooth and set exposed nails and screws.
 - .1 for opaque finishes, apply wood filler in exposed nail and screw indentations and sand smooth.
 - .2 For transparent finishes, use wax or burn-in filler which blends with surrounding color and sheen, often after stain and before final top coat.
- .2 Prime paint surfaces in Contract with cementitious materials.

PART 3 EXECUTION

3.1 Installation

- .1 Do architectural woodwork to Custom Grade Standards of the Architectural Woodwork Manufacturers Association of Canada (AWMAC), except where specified otherwise.
- .2 Install prefinished millwork at locations shown on drawings. Position accurately, level, plumb straight.
- .3 Fasten and anchor millwork securely. Provide heavy duty fixture attachments for wall mounted cabinets.

- .4 Use draw bolts in countertop joints.
- .5 Scribe and cut as required to fit abutting walls and to fit properly into recesses and to accommodate piping, columns, fixtures, outlets or other projecting, intersecting or penetrating objects.
- .6 At junction of plastic laminate counter back splash and adjacent wall finish, apply small bead of sealant.
- .7 Apply bituminous coating over wood framing members in contact with masonry or cementitious construction.
- .8 Fit hardware accurately and securely in accordance with manufacturer's directions.

3.2 Cleaning

- .1 Clean all millwork and cabinet Work inside and outside surfaces.

3.3 Protection

- .1 Protect millwork and cabinet Work from damage until final inspection.

END OF SECTION

PART 1 GENERAL

1.1 Related Sections

- .1 Section 06201 - Finish Carpentry.
- .2 Section 06400 - Architectural Woodwork: Cabinet and base units.

1.2 References

- .1 American Society for Testing and Materials (ASTM)
 - .1 ASTM D 2832-92(R1994), Standard Guide for Determining Volatile and Nonvolatile Content of Paint and Related Coatings.
 - .2 ASTM D 5116-90, Standard Guide For Small-Scale Environmental Chamber Determinations of Organic Emissions From Indoor Materials/Products.
- .2 Canadian General Standards Board (CGSB)
 - .1 CAN3-O188.1-M78, Interior Mat-Formed Wood Particle Board.
 - .2 CAN3-O188.3-M82, Exterior Bond Mat-Formed Wood Particleboard.
 - .3 CAN/CGSB-71.20-M88, Adhesive, Contact, Brushable.
- .3 Canadian Standards Association (CSA)
 - .1 CAN3-A172-M79, High Pressure, Paper Base, Decorative Laminates.
 - .2 CSA O112.4-M1977, Standards for Wood Adhesives.
 - .3 CSA O112.5-Series-M-1977, Urea Resin Adhesives for Wood (Room- and High-Temperature Curing).
 - .4 CSA O112.7-Series M-1977, Resorcinol and Phenol-Resorcinol Resin Adhesives for Wood (Room- and Intermediate-Temperature Curing).
 - .5 CSA O121-M1978, Douglas Fir Plywood.
 - .6 CAN/CSA O141-91, Softwood Lumber.
 - .7 CSA O151-M1978, Canadian Softwood Plywood.
 - .8 CSA O153-M1980, Poplar Plywood.
- .4 Environmental Choice Program (EPC)
 - .1 ECP-44-92, Adhesives.
 - .2 ECP-45-92, Sealants and Caulking Compounds.
 - .3 ECP-67-95, Recycled Water-borne Surface Coatings.

1.3 Samples

- .1 Submit samples in accordance with Section 01330- Submittal Procedures.

1.4 Closeout Submittals

- .1 Provide maintenance data for laminate Work for incorporation into manual specified in Section 01780 - Closeout Submittals.

1.5 Storage and Protection

- .1 Deliver, handle, store and protect materials of this section in accordance with Section 01610 - Basic Product Requirements.
- .2 Maintain relative humidity between 25 and 60% at 22°C during storage and installation.

1.6 Waste Management and Disposal

- .1 Refer to Section 01355.

PART 2 PRODUCTS

2.1 Materials

- .1 Laminated plastic for flatwork: to CAN3-A172, Grade GP, 1.2 mm thick; based on solid, woodgrain, or printed pattern colour range with standard finish.
 - .1 Acceptable material: Formica, Pionite, Arborite, Wilsonart, or approved equal.
- .2 Laminated plastic for postforming Work: to CAN3-A172, Grade PF, 0.7mm thick, based on solid, woodgrain, or printed pattern colour range with standard finish.
 - .1 Acceptable material: Formica, Pionite, Arborite, Wilsonart, or approved equal.
- .3 Laminated plastic backing sheet: Grade BK, not less than 0.5 mm thick or same thickness as face laminate.
- .4 Particleboard core: to CAN3-O188.1, sanded faces, of thickness indicated.
- .5 Laminated plastic adhesive: low VOC as recommended by laminate manufacturer.
 - .1 Test for acceptable VOC emissions in accordance with ASTM D 2369 and ASTM D 2832.
 - .2 Acceptable materials: ECP-44.
- .6 Sealer: water resistant sealer or glue acceptable to laminate manufacturer.
 - .1 Test for acceptable VOC emissions in accordance with ASTM D 2369 and ASTM D 2832.
 - .2 Acceptable materials: ECP-67.

- .7 Sealants: as recommended by laminate manufacturer.
- .1 Test for acceptable VOC emissions in accordance with ASTM D 2369 and ASTM D 2832.
- .2 Acceptable materials: ECP-45.
- .8 Draw bolts and splines: as recommended by fabricator.

2.2 Fabrication

- .1 Comply with CAN3-A172, Appendix 'A'.
- .2 Obtain governing dimensions before fabricating items which are to accommodate or abut appliances, equipment and other materials.
- .3 Ensure adjacent parts of continuous laminate Work match in colour and pattern.
- .4 Veneer laminated plastic to core material in accordance with adhesive manufacturer's instructions. Ensure core and laminate profiles coincide to provide continuous support and bond over entire surface. Use continuous lengths up to 2400 mm. Keep joints 600 mm from sink cutouts.
- .5 Form shaped profiles and bends as indicated, using postforming grade laminate to laminate manufacturer's instructions.
- .6 Use straight self-edging laminate strip for flatwork to cover exposed edge of core material. Chamfer exposed edges uniformly at approximately 20 degrees. Do not mitre laminate edges.
- .7 Apply laminate backing sheet to reverse side of core of plastic laminate Work.
- .8 Apply laminated plastic liner sheet where indicated.

PART 3 EXECUTION

3.1 Installation

- .1 Install Work plumb, true and square, neatly scribed to adjoining surfaces.
- .2 Make allowances around perimeter where fixed objects pass through or project into laminated plastic Work to permit normal movement without restriction.
- .3 Use draw bolts and splines in countertop joints. Maximum spacing 450 mm oc, 75 mm from edge. Make flush hairline joints.
- .4 Provide cutouts for inserts, grilles, appliances, outlet boxes and other penetrations. Round internal corners, chamfer edges and seal exposed core.
- .5 At junction of laminated plastic counter back splash and adjacent wall finish, apply small bead of sealant.

- .6 Site apply laminated plastic to units as indicated. Adhere laminated plastic over entire surface. Make corners with hairline joints. Use full sized laminate sheets. Make joints only where approved. Slightly bevel arises.
- .7 For site application, offset joints in plastic laminate facing from joints in core.

3.2 Protection

- .1 Cover finished laminated plastic, wood, and metallic veneered surfaces with heavy kraft paper or put in cartons during shipment. Protect installed laminated surfaces by approved means. Do not remove until immediately before final inspection.

END OF SECTION

PART 1 GENERAL

1.1 References

- .1 Canadian General Standards Board (CGSB)
 - .1 CAN/CGSB-37.2- M88, Emulsified Asphalt, Mineral-Colloid Type, Unfilled, for Dampproofing and Waterproofing and for Roof Coatings.
 - .2 CAN/CGSB 37.3- M89, Application of Emulsified Asphalts for Dampproofing or Waterproofing.
 - .3 CAN/CGSB 37.5- M89, Cement, Plastic, Cutback Asphalt.
 - .4 CGSB 37-GP-6Ma- 83, Asphalt, Cutback, Unfilled, for Dampproofing.
 - .5 CGSB 37-GP-9Ma- 83, Primer, Asphalt, Unfilled, for Asphalt Roofing, Dampproofing and Waterproofing.
 - .6 CGSB 37-GP-11M- 76(R1984), Application of Cutback Asphalt Plastic Cement.
 - .7 CGSB 37-GP-12Ma- 84, Application of Unfilled Cutback Asphalt for Dampproofing.
 - .8 CGSB 37-GP-15M- 76(R1984) , Application of Asphalt Primer for Asphalt Roofing, Dampproofing and Waterproofing.
 - .9 CAN/CGSB 37.16- M89, Filled, Cutback, Asphalt, for Dampproofing and Waterproofing.
 - .10 CAN/CGSB 37.28- M89, Reinforced, Mineral Colloid Type Emulsified, Asphalt for Roof Coatings and for Waterproofing.
 - .11 CGSB 37-GP-36M- 76, Application of Filled Cutback Asphalts for Dampproofing and Waterproofing.
 - .12 CGSB 37-GP-37M- 77 , Application of Hot Asphalt for Dampproofing or Waterproofing.
- .2 Canadian Standards Association (CSA)
 - .1 CSA A123.4- M1979(R1992) , Bitumen for Use in Construction of Built-Up Roof Coverings and Dampproofing and Waterproofing Systems.

1.2 Submittals

- .1 Submit proof of manufacturer's CCMC Listing and listing number to Contract Administrator.
- .2 Manufacturer's Instructions: Provide to indicate special handling criteria, installation sequence and cleaning procedures.

1.3 Product Data

- .1 Submit product data in accordance with Section 01330 - Submittal Procedures .
- .2 Submit WHMIS MSDS - Material Safety Data Sheets. WHMIS acceptable to Labour Canada, and Health and Welfare Canada.
- .3 Submit product data sheets for bituminous dampproofing products. Include:
 - .1 Product characteristics.
 - .2 Performance criteria.
 - .3 Application methods.
 - .4 Limitations.

1.4 Delivery, Storage and Handling

- .1 Deliver, handle, store and protect materials of this section in accordance with Section 01610 - Basic Product Requirements.
- .2 Provide and maintain dry, off-ground weatherproof storage.
- .3 Store materials on supports to prevent deformation.
- .4 Remove only in quantities required for same day use.
- .5 Store materials in accordance with manufacturer's written instructions.

1.5 Waste Management and Disposal

- .1 Separate and recycle waste materials in accordance with Section 01355 - Waste Management and Disposal, and with Waste Reduction Workplan.
- .2 Place materials defined as hazardous or toxic waste in designated containers.
- .3 Ensure emptied containers are sealed and stored safely for disposal away from children.
- .4 Collect and separate plastic, paper packaging and corrugated cardboard in accordance with Waste Management Plan.
- .5 Fold up metal banding, flatten and place in designated area for recycling.
- .6 Use the least toxic sealants, adhesives, sealer and primers necessary to comply with requirements of this section.
- .7 Close and seal, tightly, all partly used sealant and adhesive containers and store protected in well ventilated, fire-safe area at moderate temperature.
- .8 Place used hazardous sealant tubes and adhesive containers in areas designated for hazardous materials.

- .9 Collect, package and store part, unused containers of asphalt, sealing compounds and primers and their contents for recycling and return to recycler in accordance with Waste Management Plan.

1.6 Project/Site Environmental Requirements

- .1 Temperature, relative humidity, moisture content.
 - .1 Apply dampproofing materials only when surfaces and ambient temperatures are within manufacturers' prescribed limits.
 - .2 Do not proceed with Work when wind chill effect would tend to set bitumen before proper curing takes place.
 - .3 Maintain air temperature and substrate temperature at dampproofing installation area above 5 °C for 24 hours before, during and 24 hours after installation.
 - .4 Do not apply dampproofing in wet weather.
- .2 Safety: Comply with requirements of Workplace Hazardous Materials Information System (WHMIS) regarding use, handling, storage, and disposal of asphalt, sealing compounds, primers and caulking materials.
- .3 Ventilation:
 - .1 Ventilate area of Work as directed by Contract Administrator.
 - .2 Ventilate enclosed spaces in accordance with Section 01510 - Temporary - Utilities.

PART 2 PRODUCTS

2.1 Materials

- .1 Asphalt:
 - .1 Acceptable materials: Bakelite 710-11, SCP Insul-Mastic 7101, or approved equal
- .2 Asphalt primer: to CAN/CGSB-37.2.
 - .1 Acceptable materials: Bakelite 910-01, SCP Insul-Mastic 7501, compatible with substrate, or approved equal.

PART 3 EXECUTION

3.1 Workmanship

- .1 Keep hot asphalt:
 - .1 Below its flash point.
 - .2 At or below its final blowing temperature.
 - .3 Within its equiviscous temperature range at place of application.

3.2 Preparation

- .1 Before applying dampproofing:
 - .1 Seal exterior joints between foundation walls and footings, joints between concrete floor slab and foundation and around penetrations through dampproofing with sealing compound.

3.3 Application

- .1 Do dampproofing in accordance with CAN/CGSB-37.3 except where specified otherwise.
- .2 Do sealing Work in accordance with CGSB 37-GP-11M except where specified otherwise.
- .3 Do priming of surface in accordance with CGSB 37-GP-15M except where specified otherwise.
- .4 Apply primer.
- .5 Apply dampproofing in accordance with applicable CGSB application standard.

| Material | | Application |
|----------------|-----|----------------|
| CAN/CGSB-37.2 | use | CAN/CGSB-37.3 |
| CGSB 37-GP-6Ma | use | CGSB 37-GP-12M |
| CAN/CGSB-37.16 | use | CGSB 37-GP-36M |
| CAN/CGSB-37.28 | use | CAN/CGSB-37.3 |
| CSA A123.4 | use | CGSB 37-GP-37M |

3.4 Schedule

- .1 Apply continuous, uniform coating to entire exterior faces of foundation walls from 50 mm below finished grade level to and including tops of foundation wall footings unless indicated otherwise.
- .2 Apply continuous, uniform coating to exterior side of foundation walls enclosing rooms below finished grade. Include exterior portion of interior walls where floors in adjacent rooms are at different elevations.
- .3 Apply two additional coats of dampproofing to vertical corners and construction joints for a minimum width of 230 mm on each side, and all around and for 230 mm along pipes passing through walls.

END OF SECTION

PART 1 GENERAL

1.1 Section Includes

- .1 Materials and installation methods providing air/vapour barrier materials and assemblies.
- .2 Air/vapour barrier materials to provide continuous seal between components of building envelope and building penetrations.

1.2 Related Sections

- .1 Section 07900 - Joint Sealers.

1.3 References

- .1 Canadian General Standards Board (CGSB)
 - .1 CAN/CGSB-19.13M-M87, Sealing Compound, One Component, Elastomeric Chemical Curing.
 - .2 CAN/CGSB-19.18M-M87, Sealing Compound, One Component, Silicone Base Solvent Curing.
 - .3 CAN/CGSB-19.24M-M90, Multi-Component, Chemical Curing Sealing Compound.
 - .4 CGSB 19-GP-14M-76, Sealing Compound, One Component, Butyl-Polyisobutylene Polymer Base, Solvent Curing.
- .2 NBCC 1995; Part 5 - Environmental Separation
- .3 Sealant and Waterproofer's Institute - Sealant and Caulking Guide Specification.
- .4 National Air Barrier Association (NABA)

1.4 Quality Assurance

- .1 Perform Work in accordance with Sealant and Waterproofer's Institute - Sealant and Caulking Guide Specification requirements for materials and installation.
- .2 Perform Work in accordance with National Air Barrier Association - Professional Contractor Quality Assurance Program and requirements for materials and installation.
- .3 Maintain one copy of documents on site.

1.5 Delivery, Storage and Handling

- .1 Deliver, store and handle materials in accordance with Section 01610 - Basic Product Requirements.

- .2 Deliver, store and handle materials in accordance with manufacturer's written instructions.

1.6 Waste Management and Disposal

- .1 Separate and recycle waste materials in accordance with Section 01355 - Waste Management and Disposal, and with the Waste Reduction Workplan.

1.7 Project Environmental Requirements

- .1 Do not install solvent curing sealants or vapour release adhesive materials in enclosed spaces without ventilation.
- .2 Ventilate enclosed spaces in accordance with Section 01510 - Temporary Utilities.
- .3 Maintain temperature and humidity recommended by materials manufactures before, during and after installation.

1.8 Sequencing

- .1 Sequence Work to permit installation of materials in conjunction with related materials and seals.

1.9 Warranty

- .1 Provide a three 3 year warranty under provisions of Section 01780 - Closeout Submittals.
- .2 Warranty: Include coverage of installed sealant and sheet materials which fail to achieve air tight and watertight seal, exhibit loss of adhesion or cohesion, or do not cure.

PART 2 PRODUCTS

2.1 Sheet Materials

- .1 **Type A:** Sloped roof peel and stick vapour barrier.
 - .1 Acceptable material: Ice and water Shield, Sopraseal Stick 1100' Soprema 1.1 mil or approved equal
- .2 **Type B :** Eave protection.
 - .1 Acceptable material: 'Ice and Watersheid'-Grace, 'Sopraseal stick 100'- Soprema or approved equal.
- .3 **Type C:** Thermo-fusible vapour barrier on concrete or masonry substrate.
 - .1 Acceptable material: Blueskin TG"- Bakor, 'Sopraseal'- Soprema or approved equal.

- .4 **Type D:** Peel and stick vapour barrier for wood substrate or where open flame cannot be used.
 - .1 Acceptable material: 'Blueskin SA"- Bakor, 'Lasto Bond'- Suprema, 'Perma Barrier' Grace or approved equal.
- .5 **Type E:** Basement/crawlspace areas
 - .1 Acceptable material: 10 mil poly vapour barrier; (CAN CG SB 51.34-M86).
- .6 **Type F:** Exterior wall and roof surfaces as per drawings.
 - .1 Acceptable material: 6 mil poly vapour barrier, CMHC approved; (CAN CG SB 51.34-M86).
- .7 **Type G:** Exterior wall surface sheet air barrier.
 - .1 Acceptable material: 'Tyvek'-Dupont, 'Typar', Housewrap or approved equal.
- .8 **Type H:** Roof under asphalt shingles.
 - .1 Acceptable material: 15 lb roofing felt (CAN CG SB 51.34-M86)
- .9 **Type J:** Flat roof vapour barrier.
 - .1 Acceptable material: 'Orange label Fibrene', 'Permastop'-Fiberglass Canada or approved equal.

2.2 Sealants

- .1 Sealants in accordance with Section 07900 - Joint Sealers.

2.3 Adhesives

- .1 Mastic Adhesive: Compatible with sheet seal and substrate, thick mastic of uniform.
 - .1 Acceptable material: Tremco Acoustical Sealant, or approved equal.

2.4 Accessories

- .1 Thinner and cleaner for Butyl or Neoprene Sheet: As recommended by sheet material manufacturer. Non-staining type.
- .2 Joint Cleaner: Non-corrosive and non-staining type; recommended be sealant manufacturer; compatible with joint forming materials.
- .3 Tape: No. Y-8086, 3M Contractor's Sheathing Tape or approved equal.

PART 3 EXECUTION

3.1 Examination

- .1 Verify that surfaces and conditions are ready to accept the Work of this section.
- .2 Ensure all surfaces are clean, dry, sound, smooth, continuous and comply with air barrier manufacturer's requirements.
- .3 Report any unsatisfactory conditions to the Contract Administrator in writing.
- .4 Do not start Work until deficiencies have been corrected. Commencement of Work implies acceptance of conditions.

3.2 Preparation

- .1 Remove loose or foreign matter which might impair adhesion of materials.
- .2 Ensure all substrates are clean of oil or excess dust; all masonry joints struck flush, and open joints filled; and all concrete surfaces free of large voids, spalled areas or sharp protrusions.
- .3 Ensure all substrates are free of surface moisture prior to application of self-adhesive membrane and primer.
- .4 Ensure metal closures are free of sharp edges and burrs.
- .5 Prime substrate surfaces to receive adhesive and sealants in accordance with manufacturer's instructions.

3.3 Installation

- .1 Install materials in accordance with manufacturer's instructions.
- .2 Install per drawings and details.
- .3 Apply sealant within recommended application temperature ranges. Consult manufacturer when sealant cannot be applied within these temperature ranges.

3.4 Protection of Work

- .1 Protect finished Work in accordance with Section 01610 - Basic Product Requirements.
- .2 Do not permit adjacent Work to damage Work of this section.
- .3 Ensure finished Work is protected from climatic conditions.

END OF SECTION

PART 1 GENERAL

.1 Related Sections

- .1 Section 07190 - Vapour and Air Barriers

.2 References

- .1 American Society for Testing and Materials (ASTM)
 - .1 ASTM E96-96, Test Methods for Water Vapor Transmission of Materials.
 - .2 ASTM C208-95, Standard Specification for Cellulosic Fiber Insulating Board.
 - .3 ASTM C591-94, Standard Specification for Unfaced Preformed Rigid Cellular Polyisocyanurate Thermal Insulation.
 - .4 ASTM C726-93, Standard Specification for Mineral Fiber Roof Insulation Board.
 - .5 ASTM C728-97, Standard Specification for Perlite Thermal Insulation Board.
 - .6 ASTM C1126-98, Standard Specification for Faced or Unfaced Rigid Cellular Phenolic Thermal Insulation.
 - .7 ASTM C1289-98, Standard Specification for Faced Rigid Cellular Polyisocyanurate Thermal Insulation Board.
- .2 Canadian Gas Association (CGA)
 - .1 CAN/CGA-B149.1-M95, Natural Gas Installation Code.
 - .2 CAN/CGA-B149.2-95, Propane Installation Code.
- .3 Canadian General Standards Board (CGSB)
 - .1 CGSB 71-GP-24M-77, Adhesive, Flexible, for Bonding Cellular polystyrene Insulation.
- .4 Underwriters Laboratories of Canada (ULC)
 - .1 CAN/ULC-S701-97, Thermal Insulation, Polystyrene, Boards and Pipe Coverings.
 - .2 CAN/ULC-S702-97, Thermal Insulation, Mineral Fibre, for Buildings.

PART 2 PRODUCTS

.1 Insulation

| Properties | TYPE | | | | |
|---|---|--|---|--|--|
| | 1 | 2 | 3 | 4 | 5 |
| Thermal Resistance Minimum (R-Value/inch) | 3.7 | 4.0 | 4.75 | 5 | 4.2 |
| Moisture Absorption Maximum (% by Volume) | 6% | 4% | <2% | <1% | <1% |
| Compressive Strength Minimum (psi) | 8psi | 16psi | 20psi | 30psi | - |
| Flexural Strength Minimum (psi) | 25psi | 35psi | 44psi | 50psi | - |
| Standard of Acceptance | Beadboard Expanded Polystyrene I | Cladmate* Wallmate* Deckmate* Expanded Polystyrene II | Styrospan* Cavitymate* Cavitymate* Ultra Cellfort 200 | Styrofoam*S M Perimate* HI-40-60-100 Roofmate* Roofmate*CT Cellfort 300 | Roxul Curtain Rock FBX 1240 FIBREX |

.2 Adhesive

- .1 Adhesive (for polystyrene): to CGSB 71-GP-24, Type Bulldog Wetstick /Bulldog Grip PL 200.

.3 Accessories

- .1 Insulation clips: impale type, perforated 50 x 50 mm cold rolled carbon steel 0.8 mm thick, adhesive back, spindle of 2.5 mm diameter annealed steel, length to suit insulation, 25 mm diameter washers of self locking type.

PART 3 EXECUTION

.1 Workmanship

- .1 Install insulation after building substrate materials are dry.
- .2 Install insulation to maintain continuity of thermal protection to building elements and spaces.

- .3 Fit insulation tight around electrical boxes, plumbing and heating pipes and ducts, around exterior doors and windows and other protrusions.
- .4 Keep insulation minimum 75 mm from heat emitting devices such as recessed light fixtures, and minimum 50 mm from sidewalls of CAN4-S604 type A chimneys or as required by code, whichever is more stringent.
- .5 Cut and trim insulation neatly to fit spaces. Butt joints tightly, offset vertical joints. Use only insulation boards free from chipped or broken edges. Use largest possible dimensions to reduce number of joints.
- .6 Offset both vertical and horizontal joints in multiple layer applications.
- .7 Do not enclose insulation until it has been inspected and approved by Contract Administrator.

.2 Examination

- .1 Examine substrates and immediately inform Contract Administrator in writing of defects.
- .2 Prior to commencement of Work ensure:
 - .1 Substrates are firm, straight, smooth, dry, free of snow, ice or frost, and clean of dust and debris.

.3 Rigid Insulation Installation

- .1 Imbed insulation boards into vapour barrier type adhesive, applied as specified, prior to skinning of adhesive.
- .2 Leave insulation board joints unbonded over line of expansion and control joints. Bond a continuous 150 mm wide 0.15 mm polyethylene strip over expansion and control joints using compatible adhesive before application of insulation.

.4 Perimeter Foundation Insulation

- .1 Exterior application: extend boards full height of grade beams as indicated. Install on exterior face of perimeter foundation wall with adhesive.

END OF SECTION

PART 1 GENERAL

1.1 Related Sections

- .1 Section 07190 – Vapour and Air Barriers

1.2 References

- .1 American Society for Testing and Materials (ASTM)
 - .1 ASTM C 665-98, Standard Specification for Mineral-Fiber Blanket Thermal Insulation for Light Frame Construction and Manufactured Housing.
 - .2 ASTM C 1320-99, Standard Practice for Installation of Mineral Fiber Batt and Blanket Thermal Insulation for Light Frame Construction.
- .2 Canadian Standards Association (CSA)
 - .1 CSA B111-1974(R1998), Wire Nails, Spikes and Staples.

PART 2 PRODUCTS

2.1 Insulation

- .1 Batt and blanket mineral fibre: to ASTM C 665, Type 1, with minimum 40% recycled content thickness as indicated.
 - .1 Acceptable thermal material: Johns Manville or approved equal.

2.2 Accessories

- .1 Insulation clips where indicated:
 - .1 Impale type, perforated 50 x 50 mm cold rolled carbon steel 0.8 mm thick, adhesive back, spindle of 2.5 mm diameter annealed steel, length to suit insulation, 25 mm diameter washers of self locking type.
- .2 Nails: galvanized steel, length to suit insulation plus 25 mm, to CSA B111.
- .3 Staples: 12 mm minimum leg.
- .4 Tape: as recommended by manufacturer.

PART 3 EXECUTION

3.1 Insulation Installation

- .1 Install insulation to maintain continuity of thermal protection to building elements and spaces.
- .2 Fit insulation closely around electrical boxes, pipes, ducts, frames and other objects in or passing through insulation.

- .3 Do not compress insulation to fit into spaces.
- .4 Keep insulation minimum 75 mm from heat emitting devices such as recessed light fixtures, and minimum 50 mm from sidewalls of CAN/ULC-S604 Type A chimneys and CAN/CGA-B149.1 and CAN/CGA-B149.2 Type B and L vents.
- .5 Do not enclose insulation until it has been inspected and approved by Contract Administrator.

END OF SECTION

PART 1 GENERAL

1.1 References

- .1 Canadian General Standards Board (CGSB)
 - .1 CAN/CGSB-37.4- M89 , Fibrated, Cutback Asphalt, Lap Cement for Asphalt Roofing.
 - .2 CAN/CGSB-37.5- M89, Cutback Asphalt Plastic Cement.
 - .3 CAN/CGSB-51.32- M77, Sheathing, Membrane, Breather Type.
 - .4 CAN/CGSB-51.33- M89, Vapour Barrier Sheet, Excluding Polyethylene, for Use in Building Construction.
- .2 Canadian Roofing Contractors' Association (CRCA)
 - .1 CRCA Specification.
- .3 Canadian Standards Association (CSA)
 - .1 CSA A123.1- M1979 (R1992), Asphalt Shingles Surfaced with Mineral Granules.
 - .2 CSA A123.2- M1979 (R1992), Asphalt Coated Roofing Sheets.
 - .3 CSA A123.3- M1979, Asphalt or Tar Saturated Roofing.
 - .4 CAN3-A123.51- M85 (R1992), Asphalt Shingle Application on Roof Slopes 1:3 and Steeper.
 - .5 CAN3-A123.52- M85 (R1992), Asphalt Shingle Application on Roof Slopes 1:6 to Less Than 1:3.
 - .6 CSA B111- 1974, Wire Nails, Spikes and Staples.

1.2 Submittals

- .1 Submit proof of manufacturer's CCMC Listing and listing number to Contract Administrator.
- .2 Manufacturer's Instructions: Provide to indicate special handling criteria, installation sequence, and cleaning procedures.

1.3 Product Data

- .1 Submit product data in accordance with Section 01330 - Submittal Procedures.
- .2 Submit WHMIS MSDS - Material Safety Data Sheets. WHMIS acceptable to Labour Canada, and Health and Welfare Canada for asphalt shingles.
- .3 Submit product data sheets for asphalt shingles. Include:
 - .1 Product characteristics.

- .2 Performance criteria.
- .3 Installation instructions.
- .4 Limitations.
- .5 Colour and finish.

1.4 Samples

- .1 Submit samples in accordance with Section 01330 - Submittal Procedures.
- .2 Submit duplicate samples of full size specified shingles.

1.5 Delivery, Storage and Handling

- .1 Deliver, handle, store and protect materials in accordance with Section 01610 - Basic Product Requirements.
- .2 Provide and maintain dry, off-ground weatherproof storage.
- .3 Remove only in quantities required for same day use.

1.6 Waste Management and Disposal

- .1 Separate and recycle waste materials in accordance with Section 01355 - Waste Management and Disposal.
- .2 Place materials defined as hazardous or toxic waste in designated containers.
- .3 Ensure emptied containers are sealed and stored safely for disposal away from children.
- .4 Collect and separate plastic, paper packaging and corrugated cardboard in accordance with Waste Management Plan.
- .5 Fold up metal banding, flatten and place in designated area for recycling.
- .6 Use the least toxic sealants, and adhesives necessary to comply with requirements of this section.
- .7 Close and seal, tightly, all partly used sealant and adhesive containers and store protected in well ventilated, fire-safe area at moderate temperature.
- .8 Place used hazardous sealant tubes and adhesive containers in areas designated for hazardous materials.
- .9 Collect, package and store cut-offs and waste material from Work for recycling in accordance with Waste Management Plan.

1.7 Extra Materials

- .1 Provide maintenance materials in accordance with Section 01780 - Closeout Submittals.
- .2 All unused shingles remain property of City.

PART 2 PRODUCTS

2.1 Materials

- .1 Asphalt shingles: to CSA A123.1.
 - .1 Type: low slope and standard as indicated on drawings, pattern rectangular 3 tab, 25 year warranty.
 - .2 Colours: as selected by Contract Administrator.
 - .3 Texture: as selected by Contract Administrator.
 - .4 Acceptable material: IKO Aristocrat, BP/EMCO Rampart.
- .2 Sheathing paper: to CAN/CGSB-51.32, single ply.
- .3 Roofing felt: to CSA A123.3 organic felt No.15.
 - .1 Number of layers as indicated on drawings.
 - .2 Acceptable material: IKO, BP/EMCO Rampart or approved equal.
- .4 Cement:
 - .1 Plastic cement: to CAN/CGSB-37.5.
 - .2 Lap cement: to CAN/CGSB-37.4.
- .5 Nails: to CSA B111, of galvanized steel, sufficient length to penetrate 19 mm into deck.
- .6 Eave Protection: Refer to Section 07190 Air and Vapour Barriers to extend 900mm from line of exterior wall face up the roof slope.
- .7 Ridge Vent: Air Vent Inc. continuous ridge vent c/w associated connectors and end caps. Ridge Vents to be continuous 'Ridgemaster Plus' or approved equal as shown on drawings. Shingles to cover vents as per manufacturer's details.

PART 3 EXECUTION

3.1 Application

- .1 Do asphalt shingle Work in accordance with NBC and CRCA Specification except where specified otherwise.
- .2 Install bottom step flashing (soaker base flashing) interleaved between shingles at vertical junctions.

- .1 Install asphalt shingles on roof slopes 1:3 and steeper in accordance with CAN3-A123.51
- .2 Install asphalt shingles on roof slopes 1:6 to less than 1:3 in accordance with CAN3-A123.52.

END OF SECTION

Part 1 General

1.1 RELATED DOCUMENTS

- .1 Drawings and general provisions of the Contract, including General and Supplemental Conditions and Division 1 Specification Sections, apply to this Section.

1.2 WORK INCLUDED

- .1 The Work of this Section includes the provision of all labour, materials, equipment and services required to provide and install cement fibre siding, as indicated on the drawings, as specified herein and as required for a complete project.

1.3 RELATED WORK

- .1 Section 00301 – Separate Prices.
- .2 Section 01330 – Submittal Procedures.
- .3 Section 06100 - Rough Carpentry: Wall sheathing, sheathing membrane and strapping.
- .4 Section 06201 – Finish Carpentry
- .5 Section 07620 - Sheet Metal Flashing and Trim.
- .6 Section 09912 – Exterior Painting

1.4 REFERENCES

- .1 American Society for Testing and Materials (ASTM):
 - .1 ASTM C1185-96, Test Methods for Sampling and Testing Non-Asbestos Fiber-Cement Flat Sheet, Roofing and Siding Shingles, and Clapboards.
 - .2 ASTM E136-96a, Test Method for Behaviour of Materials in a Vertical Tube Furnace at 750°C.
- .2 Canadian General Standards Board (CGSB):
 - .1 CAN\CGSB-51.32-M77, Sheathing, Membrane, Breather Type.
- .3 Canadian Standards Association (CSA):
 - .1 CSA-B111-1974 Wire Nails, Spikes and Staples.

1.5 SUBMITTALS

- .1 General: Submit each item in this Article according to the Conditions of the Contract and the applicable Specification Section 01300.
- .2 Samples:
 - .1 Submit a sample siding panel, minimum 300 mm long, panel 300mm x 300mm.
 - .2 The accepted sample will be the standard of acceptance for the Work of this Section.

1.6 STORAGE AND HANDLING

- .1 Store materials in strict accordance with the manufacturer's recommendations.
- .2 Stack on edge or lay flat on a smooth, level surface.
- .3 Protect edges and corners to prevent chipping.
- .4 Store under cover and keep dry prior to installing. If material should become wet, allow to dry thoroughly before installing.

1.7 WARRANTY

- .1 In addition to the twelve (12) months warranty called for in GC 12.3, provide manufacturer's limited transferable product warranty but for fifty (50) years.

Part 2 - PRODUCTS

2.1 SIDING PANELS

- .1 Autoclaved manufactured non-asbestos fibre-cement siding planks composed of Portland cement, ground sand, cellulose fibre, select additives and water, characteristics as follows:
 - .1 Thickness: 8 mm
 - .2 Weight: 11.23 kg/m²
 - .3 Siding sizes : 100mm nominal
 - .4 Rot, water and salt resistant.
 - .5 Flexural strength to ASTM C1185/86 Grade II Type A: Longitudinal: 12.75 kPa
Tranverse: 17.24 kPa
 - .6 Non-combustibility to ASTM E136: Non-combustible
 - .7 Surface Burning Characteristics (ASTM E-84):
 - .1 Flame spread: 0
 - .2 Fuel contributed: 0
 - .3 Smoke developed: 5
- .2 Finish:
 - .1 As selected from manufacturers full range.
 - .2 Preprimed panels as manufactured by James Hardie Building Products.
 - .3 Standard of acceptance:
 - .1 HardiPanel by James Hardie (204.222.1983)
- 2.2 Accessories
 - .1 Underlayment: Dry sheathing to CAN/CGSB-51.32.
 - .2 Wood furring and blocking: Refer to Section 06100 "Rough Carpentry".
 - .3 Fastenings: Hot dipped galvanized corrosion resistant full round head siding nails(6mm diameter) to penetrate fully through sheathing to CSA-B35.4
 - .4 Trim, closures, cap pieces, etc.: Pine species softwood as specified in Section 06201 "Finish Carpentry".
 - .5 Patching compound: Cementitious patching compound acceptable to the siding material

- manufacturer.
- .6 Metal flashing and trim: Refer to Section 07620 "Metal Flashing and Trim".
- .7 Sealants: Refer to Section 07900 "Joint Sealants".
- .8 Finish painting: Refer to Section 09912 "Exterior Painting".

Part 3 EXECUTION

3.1 INSTALLATION

- .1 Install siding in strict accordance with the manufacturer's printed instructions.
- .2 Do not commence installation until the substrate has been inspected and approved by the Contract Administrator.
- .3 Provide underlayment over the entire area to be covered by siding. Secure in place and lap joints as per manufacturers instructions.
- .4 Install sill flashings, wood starter strips, edgings and flashings over openings.
- .5 Install siding planks in accordance with the layout indicated on the drawings.
- .6 All Work to be nail fastened. Space fasteners in accordance with the siding material manufacturer's recommendations for the site wind zone conditions.
- .7 Locate fasteners 10 mm back from plank edge and 50 mm from plank corners. Take special care to neatly align and equally space fastenings. Ensure solid backing and max pressure to air guns to be 80 lbs to prevent cracking planks.
- .8 Finish joints as indicated on the drawings and manufacturer's instructions.

3.2 Patching

- .1 Fill surface defects with cementitious patching compound and leave ready for paint finish by Section 09912 "Exterior Painting"

END OF SECTION

Part 1 General

1.1 RELATED SECTIONS

- .1 Section 01330 – Submittal Procedures

1.2 WORK INCLUDED

- .1 The Work included under this section shall conform to the definitions in the "Manitoba Trade Definition" handbook produced by the Winnipeg Construction Association.

1.3 SUBMITTALS

- .2 Submit shop drawings to requirements of Section 01330.
- .3 Indicate on shop drawings, dimensioning, panel layout, general construction details, anchorages and method of anchorage, and method of installation.
- .4 Submit samples to requirements of Section 01330.

Part 2 Products

2.1 MATERIALS

- .1 Corrugated Wall Panels – Type 1: ASTM A525, Grade A, Z275 zinc coating; 0.76 mm core steel, AZ180 Galvalume steel. Profile: VicWest 1/2" corrugated cladding or approved equal.
- .2 Sheet Air Barrier/Building Paper: as specified in Section 07190.
- .3 Subgrits, Clips, Spacers: minimum 1.2 mm thick formed galvanized steel; ASTM 446 Grade A, zinc coating designation Z275.

2.2 ACCESSORIES

- .1 Sealants: Manufacturer's standard type suitable for use in conjunction with installation of panel siding; non-staining; non-corrosive; non-shrinking and non-sagging; ultra-violet and ozone resistant for exterior applications; colour to match siding colour.
- .2 Fasteners: Galvanized steel with fiberglass reinforced nylon head and soft neoprene washer, at exposed locations. Finish exposed fasteners same as flashing metal.

2.3 COMPONENT FABRICATION

- .1 Siding and Soffit Panels: minimum 22 ga thick sheet stock; widths to suit application; lapped edges fitted with continuous length sealant or gaskets.
- .2 Internal and External Corners: Same materials, material thickness and finish as siding; brake formed. Exposed fasteners are to have same finish as siding. Pop rivets to be stainless steel prefinished.
- .3 Flashings, Closures & Trim Pieces: Same material, and where exposed of same sheet stock; brake formed to required profiles.

Part 3 Execution

3.1 INSTALLATION

- .1 Install preformed metal panel siding on walls in accordance with manufacturer's recommendations.
- .2 Fabrication of exposed siding components on site is not permitted.
- .3 Exercise care when cutting siding on site, to ensure cuttings do not remain on finish surfaces. All cuts to be cleaned with cut edge filed smooth or hand trimmed.
- .4 Protect siding surfaces in contact with cementitious materials and other dissimilar metals with bituminous paint. Allow protective coating to dry prior to installing members.
- .5 Permanently fasten siding system to structural supports, properly aligned, levelled and plumb. Maximum offset from true alignment between adjacent members butting or in line to be 2 mm. Maximum variations from plane or location indicated on drawings to be 3 mm.
- .6 Locate end laps over supports. End lap panels minimum 50 mm. Ensure sidelaps are over firm bearings.
- .7 Provide expansion joints where indicated on drawings.
- .8 Use concealed fasteners where possible; exposed fasteners in all other locations.
- .9 Install sealant where required to arrest direct weather penetration.
- .10 Complete installation is to be free of rattles, noise due to thermal movement, and wind whistles.
- .11 Install in accordance with rain screen principles.

END OF SECTION

PART 1 GENERAL

1.1 Related Work

- .1 Metal flashing: Section 07620 Metal Flashing and Trim.
- .2 Caulking: Section 07900 Joint Sealers.

1.2 References

- .1 American Society for Testing and Materials (ASTM)
 - .1 ASTM C 36-95b, Specification for Gypsum Wallboard.
- .2 Canadian General Standards Board (CGSB)
 - .1 CAN/CGSB-37.5-M89, Cutback Asphalt Plastic Cement.
 - .2 CGSB 37-GP-9Ma-83, Primer, Asphalt, Unfilled, for Asphalt Roofing, Dampproofing and Waterproofing.
 - .3 CGSB 37-GP-15M-76, Application of Asphalt Primer for Asphalt Roofing, Dampproofing and Waterproofing.
 - .4 CGSB 37-GP-19M-76, Cement, Plastic, Cutback Tar.
 - .5 CAN/CGSB-37.29-M89, Rubber-Asphalt Sealing Compound.
 - .6 CGSB 37-GP-56M-80, Membrane, Modified, Bituminous, Prefabricated, and Reinforced for Roofing.
 - .7 CAN/CGSB-51.20-M87, Thermal Insulation, Polystyrene, Boards and Pipe Covering.
 - .8 CAN/CGSB-51.26-M86, Thermal Insulation, Urethane and Isocyanurate, Boards, Faced.
 - .9 CAN/CGSB-51.31-M84, Thermal Insulation, Mineral Fibre Board for Above Roof Decks.
 - .10 CAN/CGSB-51.33-M89, Vapour Barrier Sheet, Excluding Polyethylene, for Use in Building Construction.
 - .11 CAN/CGSB-51.34-M86, Vapour Barrier, Polyethylene Sheet for Use in Building Construction.
 - .12 CAN/CGSB 51.38-92, Cellular Glass Thermal Insulation.
- .3 Canadian Standards Association (CSA)
 - .1 CSA A123.3-M1992, Asphalt or Tar Saturated Roofing Felt.
 - .2 CSA A123.4-M1992, Bitumen for Use in Construction of Built-Up Roof Coverings and Dampproofing and Waterproofing Systems.
 - .3 CAN/CSA-A247-M86, Insulating Fibreboard.
 - .4 CSA A284-1976, Mineral Aggregate Thermal Roof Insulation.
 - .5 CSA O121-M1978, Douglas Fir Plywood.

.6 CSA O151-M1978, Canadian Softwood Plywood.

1.3 Storage and Handling

- .4 Provide and maintain dry, off-ground weatherproof storage.
- .5 Store rolls of felt and membrane in upright position. Store membrane rolls with selvage edge up.
- .6 Remove only in quantities required for same day use.
- .7 Place plywood runways over Work to enable movement of material and other traffic.
- .8 Store sealants at +5°C minimum.
- .9 Store insulation protected from daylight and weather and deleterious materials.

1.4 Environmental Requirements

- .1 Do not install roofing when temperature remains below -18°C for torch application, or -10°C or manufacturers' recommendations for mop application.
- .2 Minimum temperature for solvent-based adhesive is -5°C.
- .3 Install roofing on dry deck, free of snow and ice, use only dry materials and apply only during weather that will not introduce moisture into roofing system.

1.5 Protection

- .10 Fire Extinguishers: maintain one cartridge operated type with hose and shut-off nozzle, ULC labelled for A, B and C class protection. Size 9 kg on roof per torch applicator, within 10 m of torch applicator.
- .11 Maintain fire watch for 1 hour after each day's roofing operations cease.

1.6 Warranty

- .12 For the Work of this Section 07550 - Modified Bituminous Roofing, the 12 months warranty period prescribed in subsection GC 13.2 of General Conditions "C" is extended to 60 months. Material warranty is 10 years non-prorated.

1.7 Compatibility

- .13 Compatibility between components of roofing system is essential. Provide written declaration to Contract Administrator stating that materials and components, as assembled in system, meet this requirement.

1.8 Quality Assurance

- .14 Submit laboratory test reports in accordance with Section 01450 - Quality Control.

- .15 Installers to be CRCA member or RCAM member (in Manitoba) with 5 years minimum experience.

PART 2 PRODUCTS

2.1 Membrane

- .1 Base sheet: to CGSB 37-GP-56M, Styrene-Butadiene-Styrene (SBS) elastomeric polymer thermoplastic polymer, prefabricated sheet, polyester reinforcement, weighing 180 g/m²
 - .1 Type 1, fully adhered.
 - .2 Type 2, fully adhered loose laid.
 - .3 Class A - C - plain surfaced.
 - .4 Grade 1 - heavy duty service.
 - .5 Top and bottom surfaces:
 - .1 Polyethylene/polyethylene.
 - .6 Acceptable material: Soprabase 1/2 FR board with laminated base sheet or approved equal.
- .2 Cap sheet: to CGSB 37-GP-56M, Styrene-Butadiene-Styrene (SBS) elastomeric polymer thermoplastic polymer, prefabricated sheet, polyester reinforcement, weighing 250 g/m².
 - .1 Type 1, fully adhered.
 - .2 Class A-granule surfaced.
 - .3 Grade heavy duty service.
 - .4 Bottom surface polyethylene.
 - .5 Acceptable material: Sopralene Flam 250 or approved equal, granulated, colour from standard range (non-metallic) colors.

2.2 Insulating Fibreboard

- .1 To CAN/CSA-A247, Type 1-roof board, surface coated, 6.4 mm thick.
 - .1 Acceptable material: Soprabase or approved equal.

2.3 Membrane Flashing

- .1 Acceptable material: Sopraflash, Flamstick (poly), or approved equal.

2.4 Sealers

- .1 Plastic cement: asphalt, SBS to CAN/CGSB-37.5, to CGSB 37-GP-19M.
 - .1 Acceptable material: Sopramastic, or approved equal.

- .2 Sealing compound: to CAN/CGSB-37.29, rubber asphalt type.
 - .1 Acceptable material: Sopramastic, or approved equal
- .3 Sealants: Sopramastic or approved equal.

2.5 Fasteners

- .1 Covering to steel deck: No. 10 flat head, self tapping, Type A or AB, cadmium plated screws to CSA B35.3.
- .2 Insulation to deck: fasteners and 50mm plates minimum must meet Factory Mutual 4470 Standard for wind uplift and corrosion resistance.

PART 3 EXECUTION

3.1 Workmanship

- .1 Do roofing Work in accordance with applicable, standard in Canadian Roofing Contractors Association (CRCA) Roofing Specifications Manual.
- .2 Do priming for asphalt roofing in accordance with CGSB 37-GP-15M.

3.2 Protection

- .1 Cover walls and adjacent Work where materials hoisted or used.
- .2 Use warning signs and barriers. Maintain in good order until completion of Work.
- .3 Clean off drips and smears of bituminous material immediately.
- .4 Dispose of rain water off roof and away from face of building until roof drains or hoppers installed and connected.
- .5 Protect roof from traffic and damage. Comply with precautions deemed necessary by Contract Administrator.
- .6 At end of each day's Work or when stoppage occurs due to inclement weather, provide protection for completed Work and materials out of storage.

3.3 Examination of Roof Decks

- .1 Examine roof decks and immediately inform Contract Administrator in writing of defects.
- .2 Inform Contract Administrator 24 hours prior to beginning Work.
- .3 Prior to commencement of Work ensure:
 - .1 Decks are firm, straight, smooth, dry, free of snow, ice or frost, and swept clean of dust and debris.
 - .2 Curbs have been built.

- .3 Roof drains have been installed at proper elevations relative to finished roof surface.
- .4 Plywood and lumber nailer plates have been installed to deck, walls and parapets as indicated.

3.4 Exposed Membrane Roofing Application

- .1 Base sheet application.
 - .1 Fasten boards mechanically in conformance with illustrations in Specifications manual.
 - .2 All panels must be in perfect condition, without any significant differences in level, and must be adhered on all their surfaces completely.
 - .3 Complete side laps sealing by torching seal end overlaps in a similar fashion.
 - .4 All vertical joints between substrate and boards will be staggered vertically and horizontally.
- .2 Cap sheet application.
 - .1 Starting at low point on roof, perpendicular to slope, unroll cap sheet, align and reroll from both ends.
 - .2 Unroll and embed cap sheet in uniform coating of asphalt applied at rate of 1.2 kg/m², EVT at point of contact.
 - .3 Unroll and torch cap sheet onto base sheet taking care not to burn membrane or its reinforcement.
 - .4 Lap sheets 75 mm minimum for side laps and 150 mm minimum for end laps. Offset joints in cap sheet 300 mm minimum from those in base sheet.
 - .5 Application to be free of blisters, fishmouths and wrinkles.
 - .6 Do membrane application in accordance with manufacturer's recommendations.
- .3 Flashings.
 - .1 Complete installation of flashing base sheet stripping prior to installing membrane cap sheet.
 - .2 Torch cap sheet onto substrate in 1 metre wide strips.
 - .3 Lap flashing base sheet to membrane base sheet minimum 150 mm and seal by torch welding.
 - .4 Lap flashing cap sheet to membrane cap sheet 250 mm minimum and torch weld.
 - .5 Provide 75 mm minimum side lap and seal.
 - .6 Properly secure flashings to their support, without sags, blisters, fishmouths or wrinkles.
 - .7 Do Work in accordance with manufacturer's recommendations.

END OF SECTION

Part 1 General

1.01 WORK INCLUDED

- .1 The Work included under this section shall conform to the industry standard and be accepted by the local construction and trade associations.

Part 2 Products

2.01 SHEET MATERIALS

- .1 Pre-coated Galvanized Steel: ASTM A525, Z275 zinc coating; 0.6 mm (24 ga.) core steel in all installed locations higher than 2 meters, 1.2 mm (18 ga.) core steel in all installed locations at or lower than 2 meters, shop pre-coated galvalume.
- .2 Galvalume sheet steel: commercial quality to ASTM A 653 with Z275 designation zinc coating, 24 ga. thickness.
- .3 Fascia: Pre-coated Galvalume Steel: ASTM A525, Z275 zinc coating; 0.6 mm (24 ga.) core steel in all installed shop pre-galvanized.

2.02 ACCESSORIES

- .1 Fastener: Galvanized steel with fiberglass reinforced nylon head and soft neoprene washer, at exposed locations. Finish exposed fasteners same as flashing metal.
- .2 Sealant: silicone; colour-grey where not exposed to site and to match adjacent materials where exposed
- .3 Tape: isobutyl, colour grey 3x25
- .4 Fasteners: same material as sheet metal to CSA B111, flat head roofing nails.
- .5 Washers: of same material as sheet metal, 1mm thick with rubber packings.
- .6 Isolation coating: to CAN/CGSB-1.108
- .7 Isolate dissimilar metals from reacting.

2.03 FABRICATION

- .1 Form sections true to shape, accurate in size, square, and free from distortion or defects.
- .2 Fabricate cleats, clips, and starter strips of same material as sheet, inter-lockable with sheet.
- .3 Form pieces in longest practical lengths.
- .4 Hem exposed edges on underside 13 mm; miter and seam corners.
- .5 Form material with flat lock seam.
- .6 Seal all joints with silicone.
- .7 Fabricate corners from one piece with minimum 450 mm long legs; solder for rigidity, seal with silicone sealant.
- .8 Fabricate vertical faces with bottom edge formed outward 6 mm and hemmed to form drip.
- .9 On exposed faces, return drip edge hem back to form interlock with concealed clip. Provide continuous clips at all exposed faces.
- .10 Fabricate flashings to allow toe to extend 50 mm over roofing. Return and brake edges.

Part 3 Execution

3.01 INSPECTION

- .1 Verify roof openings, curbs, pipes, sleeves, ducts, or vents through roof are solidly set, cant strips and reglets in place, and nailing strips located.
- .2 Verify membrane termination and base flashings are in place, sealed, and secure.
- .3 Beginning of installation means acceptance of existing conditions.

3.02 PREPARATION

- .1 Field measure site conditions prior to fabricating Work.
- .2 Install starter and edge strips, and cleats before starting installation.

3.03 INSTALLATION

- .1 Install surface mounted reglets true to lines and levels. Seal top of reglets with sealant.
- .2 Secure flashings in place using concealed continuous clip fasteners at all visible flashings. Use exposed fasteners only in locations not ordinarily visible (e.g. - inside parapet walls). All exposed fasteners must be on vertical surfaces.
- .3 Apply plastic cement compound between metal flashings and felt flashings.
- .4 Fit flashings tight in place. Make corners square, surfaces true and straight in planes, and lines accurate to profiles.
- .5 Seal metal joints watertight.
- .6 Clean any drippage and spills of surplus sealant or plastic cement from adjacent surfaces and make good any damage caused by the Work.

END OF SECTION

PART 1 GENERAL

1.1 Related Work

- .1 Fire stopping and smoke seals within mechanical assemblies (i.e inside ducts, dampers) and electrical assemblies (i.e. inside cable trays) are specified in Division 15 and 16 respectively.

1.2 References

- .1 Underwriter's Laboratories of Canada (ULC)
 - .1 ULC-S115-1995, Fire Tests of Firestop Systems.

1.3 Samples

- .1 Submit samples in accordance with Section 01330 - Submittal Procedures.

1.4 Shop Drawings

- .1 Submit shop drawings in accordance with Section 01330 - Submittal Procedures.
- .2 Submit shop drawings to show proposed material, reinforcement, anchorage, fastenings and method of installation. Construction details should accurately reflect actual job conditions.

1.5 Product Data

- .1 Submit product data in accordance with Section 01330 - Submittal Procedures.
- .2 Submit manufacturer's product data for materials and prefabricated devices, providing descriptions are sufficient for identification at job site. Include manufacturer's printed instructions for installation.

1.6 Waste Management and Disposal

- .1 Separate and recycle waste materials in accordance with Section 01355 - Waste Management and Disposal.
- .2 Collect and separate plastic, paper packaging and corrugated cardboard in accordance with Waste Management Plan.

PART 2 PRODUCTS

2.1 Materials

- .1 Fire stopping and smoke seal systems: in accordance with ULC-S115.
 - .1 Asbestos-free materials and systems capable of maintaining an effective barrier against flame, smoke and gases in compliance with requirements

of ULC-S115 and not to exceed opening sizes for which they are intended.

- .2 Firestop system rating: 1 hour.
- .2 Service penetration assemblies: certified by ULC in accordance with ULC-S115 and listed in ULC Guide No.40 U19.
- .3 Service penetration firestop components: certified by ULC in accordance with ULC-S115 and listed in ULC Guide No.40 U19.13 and ULC Guide No.40 U19.15 under the Label Service of ULC.
- .4 Fire-resistance rating of installed fire stopping assembly in accordance with NBC.
- .5 Fire stopping and smoke seals at openings intended for ease of re-entry such as cables: elastomeric seal.
- .6 Fire stopping and smoke seals at openings around penetrations for pipes, ductwork and other mechanical items requiring sound and vibration control: elastomeric seal.
- .7 Primers: to manufacturer's recommendation for specific material, substrate, and end use.
- .8 Water (if applicable): potable, clean and free from injurious amounts of deleterious substances.
- .9 Damming and backup materials, supports and anchoring devices: to manufacturer's recommendations, and in accordance with tested assembly being installed as acceptable to authorities having jurisdiction.
- .10 Sealants for vertical joints: non-sagging.

PART 3 EXECUTION

3.1 Preparation

- .1 Examine sizes and conditions of voids to be filled to establish correct thicknesses and installation of materials. Ensure that substrates and surfaces are clean, dry and frost free.
- .2 Prepare surfaces in contact with fire stopping materials and smoke seals to manufacturer's instructions.
- .3 Maintain insulation around pipes and ducts penetrating fire separation without interruption to vapour barrier.
- .4 Mask where necessary to avoid spillage and over coating onto adjoining surfaces; remove stains on adjacent surfaces.

3.2 Installation

- .1 Install fire stopping and smoke seal material and components in accordance with ULC certification and manufacturer's instructions.
- .2 Seal holes or voids made by through penetrations, poke-through termination devices, and unpenetrated openings or joints to ensure continuity and integrity of fire separation are maintained.
- .3 Provide temporary forming as required and remove forming only after materials have gained sufficient strength and after initial curing.
- .4 Tool or trowel exposed surfaces to a neat finish.
- .5 Remove excess compound promptly as Work progresses and upon completion.

3.3 Inspection

- .1 Notify Contract Administrator when ready for inspection and prior to concealing or enclosing firestopping materials and service penetration assemblies.

3.4 Schedule

- .1 Firestop and smoke seal at:
 - .1 Penetrations through fire-resistance rated masonry, concrete, and gypsum board partitions and walls.
 - .2 Top of fire-resistance rated masonry and gypsum board partitions.
 - .3 Intersection of fire-resistance rated masonry and gypsum board partitions.
 - .4 Control and sway joints in fire-resistance rated masonry and gypsum board partitions and walls.
 - .5 Penetrations through fire-resistance rated floor slabs, ceilings and roofs.
 - .6 Openings and sleeves installed for future use through fire separations.
 - .7 Around mechanical and electrical assemblies penetrating fire separations.
 - .8 Rigid ducts: greater than 129 cm²: fire stopping to consist of bead of fire stopping material between retaining angle and fire separation and between retaining angle and duct, on each side of fire separation.

3.5 Clean Up

- .1 Remove excess materials and debris and clean adjacent surfaces immediately after application.
- .2 Remove temporary dams after initial set of fire stopping and smoke seal materials.

END OF SECTION

PART 1 GENERAL

1.1 References

- .1 CAN/CGSB-19.1-M87, Putty, Linseed Oil Type.
- .2 CAN/CGSB-19.2-M87, Glazing Compound, Nonhardening, Modified Oil Type.
- .3 CGSB 19-GP-5M-76, Sealing Compound, One Component, Acrylic Base, Solvent Curing.
- .4 CAN/CGSB-19.6-M87, Caulking Compound, Oil Base.
- .5 CAN/CGSB-19.13-M87, Sealing Compound, One-component, Elastomeric, Chemical Curing.
- .6 CGSB 19-GP-14M-76, Sealing Compound, One Component, Butyl-polyisobutylene Polymer Base, Solvent Curing.
- .7 CAN/CGSB-19.17-M90, One-Component Acrylic Emulsion Base Sealing Compound.
- .8 CAN/CGSB-19.18-M87, Sealing Compound, One Component, Silicone Base, Solvent Curing.
- .9 CAN/CGSB-19.21-M87, Sealing and Bedding Compound Acoustical.
- .10 CAN/CGSB-19.22-M89, Mildew Resistant, Sealing Compound for Tubs and Tiles.
- .11 CAN/CGSB-19.24-M90, Multi-component, Chemical Curing Sealing Compound.

1.2 Samples

- .1 Submit samples in accordance with Section 01330 - Submittal Procedures.

1.3 Delivery, Storage, and Handling

- .1 Deliver, handle, store and protect materials in accordance with Section 01610 - Basic Product Requirements.
- .2 Deliver and store materials in original wrappings and containers with manufacturer's seals and labels, intact. Protect from freezing, moisture, water and contact with ground or floor.

1.4 Environmental and Safety Requirements

- .1 Comply with requirements of Workplace Hazardous Materials Information System (WHMIS) regarding use, handling, storage, and disposal of hazardous

materials; and regarding labelling and provision of material safety data sheets acceptable to Labour Canada.

- .2 Conform to manufacturer's recommended temperatures, relative humidity, and substrate moisture content for application and curing of sealants including special conditions governing use.
- .3 Ventilate area of work as directed by Contract Administrator by use of approved portable supply and exhaust fans.

1.5 Waste Management and Disposal

- .1 Separate and recycle waste materials in accordance with Section 01355 - Waste Management and Disposal and the Waste Reduction Workplan.
- .2 Place materials defined as hazardous or toxic waste in designated containers.
- .3 Ensure emptied containers are sealed and stored safely for disposal away from children.
- .4 Dispose of surplus chemical and finishing materials in accordance with federal, provincial and municipal regulations.
- .5 Separate corrugated cardboard in accordance with the Waste Management Plan and place in designated areas for recycling.
- .6 Fold up metal banding, flatten, and place in designated area for recycling.
- .7 Use trigger operated spray nozzles for water hoses.
- .8 Return solvent and oil soaked rags for contaminant recovery and laundering or for proper disposal.
- .9 Use the least toxic sealants, adhesives, sealers, and finishes necessary to comply with the requirements of this section.
- .10 Close and seal tightly all partly used sealant containers and store protected in well ventilated fire-safe area at moderate temperature.
- .11 Place used hazardous sealant tubes and other containers in areas designated for hazardous materials.

PART 2 PRODUCTS

2.1 Sealant Materials

- .1 Sealants and caulking compounds must:
 - .1 meet or exceed all applicable governmental and industrial safety and performance standards; and

- .2 be manufactured and transported in such a manner that all steps of the process, including the disposal of waste products arising therefrom, will meet the requirements of all applicable governmental acts, by laws and regulations including, for facilities located in Canada, the fisheries Act and the Canadian Environmental Protection Act (CEPA).
- .2 Sealant and caulking compounds must not be formulated or manufactured with: aromatic solvents, fibrous talc or asbestos, formaldehyde, halogenated solvents, mercury, lead, cadmium, hexavalent chromium, barium or their compounds, except barium sulfate.
- .3 Sealant and caulking compounds must not contain a total of volatile organic compounds (VOCs) in excess of 5% by weight as calculated from records of the amounts of constituents used to make the product;
- .4 Sealant and caulking compounds must be accompanied by detailed instructions for proper application so as to minimize health concerns and maximize performance, and information describing proper disposal methods.
- .5 Caulking that emits strong odours, contains toxic chemicals or is not certified as mould resistant shall not be used in air handling units.
- .6 When low toxicity caulks are not possible, confine usage to areas which offgas to the exterior, are contained behind air barriers, or are applied several months before occupancy to maximize off-gas time.
- .7 In the selection of the products and materials of this section preference will be given to those with the following characteristics: non-flammable, low Volatile Organic Compound (VOC) content, manufactured without compounds which contribute to ozone depletion in the upper atmosphere, does not contain methylene chloride, does not contain chlorinated hydrocarbons.
- .8 Sealants acceptable for use on this project except CAN/CGSB-19.1 and CAN/CGSB-19.18 must be listed on CGSB Qualified Products List issued by CGSB Qualification Board for Joint Sealants. Where sealants are qualified with primers use only these primers.

2.2 Sealant Material Designations

- .1 Neoprene or Butyl Rubber.
 - .1 Round solid rod, Shore A hardness 70.
- .2 High Density Foam.
 - .1 Extruded closed cell polyvinyl chloride (PVC), extruded polyethylene, closed cell, Shore A hardness 20, tensile strength 140 to 200 kPa, extruded polyolefin foam, 32 kg/m³ density, or neoprene foam backer, size as recommended by manufacturer.
- .3 Bond Breaker Tape.
 - .1 Polyethylene bond breaker tape which will not bond to sealant.

- .4 Polyurethane Sealant.
 - .1 CAN 19.13-M87; single component, high performance, non-sagging, low modulus, non-staining and non-bleeding. to be used at all exterior and interior control / expansion joints and on the exterior side of all window / door frame perimeters. Color as selected by the Architect. Standard of acceptance: Tremco Dymonic or approved equal.
- .5 Latex Sealant.
 - .1 CGSB 19-GP-17M; single component, non-sagging, non-staining. To be used on the interior side of all exterior window / door frame perimeters and at all interior window / door frame perimeters. Color as selected by the Architect. Standard of Acceptance: Tremco 200 latex or approved equal.
- .6 Silicone Sealant.
 - .1 CGSB 19-GP-9M; single component, fungus resistant, non-sagging, non-staining, non-bleeding, moisture curing. To be used in all sloped glazing, skylights, and at all joints between vanities, countertops, backsplashes and adjacent wall materials and at the joint between bathtubs and finish flooring in washrooms. Color as selected by Architect. Standard of Acceptance: Tremco Proglaze or approved equal.

2.3 Joint Cleaner

- .1 Non-corrosive and non-staining type, compatible with joint forming materials and sealant recommended by sealant manufacturer.
- .2 Primer: as recommended by manufacturer.

PART 3 EXECUTION

3.1 Protection

- .1 Protect installed work of other trades from staining or contamination.

3.2 Preparation of Joint Surfaces

- .1 Examine joint sizes and conditions to establish correct depth to width relationship for installation of backup materials and sealants.
- .2 Clean bonding joint surfaces of harmful matter substances including dust, rust, oil grease, and other matter which may impair work.
- .3 Do not apply sealants to joint surfaces treated with sealer, curing compound, water repellent, or other coatings unless tests have been performed to ensure compatibility of materials. Remove coatings as required.

- .4 Ensure joint surfaces are dry and frost free.
- .5 Prepare surfaces in accordance with manufacturer's directions.

3.3 Priming

- .1 Where necessary to prevent staining, mask adjacent surfaces prior to priming and caulking.
- .2 Prime sides of joints in accordance with sealant manufacturer's instructions immediately prior to caulking.

3.4 Backup Material

- .1 Apply bond breaker tape where required to manufacturer's instructions.
- .2 Install joint filler to achieve correct joint depth and shape, with approximately 30 % compression.

3.5 Mixing

- .1 Mix materials in strict accordance with sealant manufacturer's instructions.

3.6 Application

- .1 Sealant.
 - .1 Apply sealant in accordance with manufacturer's written instructions.
 - .2 Mask edges of joint where irregular surface or sensitive joint border exists to provide neat joint.
 - .3 Apply sealant in continuous beads.
 - .4 Apply sealant using gun with proper size nozzle.
 - .5 Use sufficient pressure to fill voids and joints solid.
 - .6 Form surface of sealant with full bead, smooth, free from ridges, wrinkles, sags, air pockets, embedded impurities.
 - .7 Tool exposed surfaces before skinning begins to give slightly concave shape.
 - .8 Remove excess compound promptly as work progresses and upon completion.
- .2 Curing.
 - .1 Cure sealants in accordance with sealant manufacturer's instructions.
 - .2 Do not cover up sealants until proper curing has taken place.
- .3 Cleanup.

- .1 Clean adjacent surfaces immediately and leave work neat and clean.
- .2 Remove excess and droppings, using recommended cleaners as work progresses.
- .3 Remove masking tape after initial set of sealant.

END OF SECTION

PART 1 GENERAL

1.1 Related Sections

- .1 Section 00870 – Door and Hardware Schedule.
- .2 Section 07900 - Joint Sealers: Caulking of joints between frames and other building components.
- .3 Section 08710 - Door Hardware: Supply of finish hardware, including weather stripping and mounting heights.
- .4 Section 08800 - Glazing: Glazing.
- .5 Section 09911 - Interior Painting.
- .6 Division 16: Wiring for electronic hardware.

1.2 References

- .1 American Society for Testing and Materials (ASTM).
 - .1 ASTM A 653M-95, Specification for Steel Sheet, Zinc-Coated (Galvanized) or Zinc-Iron Alloy-Coated (Galvanealed) by the Hot-Dip Process.
 - .2 ASTM B 29-[92], Specification for Pig Lead.
 - .3 ASTM B 749-85(1991), Specification for Lead and Lead Alloy Strip, Sheet and Plate Products.
- .2 Canadian General Standards Board (CGSB).
 - .1 CAN/CGSB-1.181-92, Ready-Mixed Organic Zinc-Rich Coating.
 - .2 CGSB 41-GP-19Ma-84, Rigid Vinyl Extrusions for Windows and Doors.
 - .3 CAN/CGSB-51.20-M87, Thermal Insulation, Polystyrene, Boards and Pipe Covering.
 - .4 CGSB 51-GP-21M-78, Thermal Insulation, Urethane and Isocyanurate, Unfaced.
- .3 Canadian Standards Association (CSA).
 - .1 CSA A101-M1983, Thermal Insulation, Mineral Fibre, for Buildings.
 - .2 CAN/CSA-G40.21-M92, Structural Quality Steels.
 - .3 CSA W59-M1989, Welded Steel Construction (Metal Arc Welding).
- .4 Canadian Steel Door and Frame Manufacturers' Association, (CSDFMA).
 - .1 CSDFMA, Specifications for Commercial Steel Doors and Frames, 1990.

- .2 CSDFMA, Recommended Selection and Usage Guide for Commercial Steel Doors, 1990.
- .5 National Fire Protection Association (NFPA).
 - .1 NFPA 80-1992, Fire Doors and Windows.
 - .2 NFPA 252-1990, Door Assemblies, Fire Tests of.
- .6 Underwriters' Laboratories of Canada (ULC).
 - .1 CAN4-S104M- M80(R1985), Fire Tests of Door Assemblies.
 - .2 CAN4-S105M-M85, Fire Door Frames.

1.3 Design Requirements

- .1 Design exterior frame assembly to accommodate to expansion and contraction when subjected to minimum and maximum surface temperature of -35°C to 35°C.
- .2 Maximum deflection for exterior steel entrance screens under wind load of 1.2 kPa not to exceed 1/175th of span.

1.4 Shop Drawings

- .1 Submit shop drawings in accordance with Section 01330 - Submittal Procedures.
- .2 Indicate each type of door, material, steel core thicknesses, mortises, reinforcements, location of exposed fasteners, openings, glazed, louvred, arrangement of hardware and fire rating and finishes.
- .3 Indicate each type frame material, core thickness, reinforcements, glazing stops, location of anchors and exposed fastenings and reinforcing, firerating, finishes.
- .4 Include schedule identifying each unit, with door marks and numbers relating to numbering on drawings and door schedule.
- .5 Submit test and engineering data, and installation instructions.

1.5 Requirements of Regulatory Agencies

- .1 Steel fire rated doors and frames: labelled and listed by an organization accredited by Standards Council of Canada in conformance with CAN4-S104M for ratings specified or indicated.
- .2 Provide fire labelled frame products for those openings requiring fire protection ratings, as scheduled. Test products in strict conformance with CAN4-S104, ASTM E 152 or NFPA 252 and list by nationally recognized agency having factory inspection service and construct as detailed in Follow-Up Service Procedures/Factory Inspection Manuals issued by listing agency to individual manufacturers.

1.6 Waste Management and Disposal

- .1 Separate and recycle waste materials in accordance with Section 01355 - Waste Management and Disposal and the Waste Reduction Workplan.
- .2 Ensure emptied containers are sealed and stored safely for disposal away from children.
- .3 Close and seal tightly all partly used sealant and adhesive containers and store protect in well ventilated fire-safe area at moderate temperature.
- .4 Separate corrugated cardboard in accordance with the Waste Management Plan and place in designated areas for recycling.
- .5 Fold up metal banding, flatten, and place in designated area for recycling.
- .6 Collect wood packing shims and pallets and place in designated area for recycling and reuse.
- .7 Do not dispose of paints or solvents by pouring on the ground. Place in designated containers and ensure proper disposal in accordance with federal, provincial and municipal regulations.
- .8 Solvent based paints, which cannot be reused must be treated as hazardous waste and disposed of in an appropriate manner in accordance with hazardous waste regulations. Empty paint cans are to be dry prior to disposal or recycling (where available).
- .9 Where paint recycling is available, collect all waste paint by type and provide for delivery to recycling or collection facility.
- .10 Paints and finishes are regarded as hazardous products and are subject to regulations for their disposal. Information on these controls can be obtained from the Provincial Ministries of Environment and Regional levels of Government.

PART 2 PRODUCTS

2.1 Materials

- .1 Hot dipped galvanized steel sheet: to ASTM A 653M, minimum base steel thickness in accordance with CSDFMA Table 1 - Thickness for Component Parts.
- .2 Reinforcement channel: to CAN/CSA-G40.21, Type 44W, coating designation to ASTM A 653M.
- .3 Cast or rolled pure sheet lead: to ASTM B 29, weight: 14.6 kg/m², thickness 1.2 mm.

- .4 Composites: balance of core materials used in conjunction with lead: in accordance with manufacturers' proprietary design.

2.2 Door Core Materials

- .1 Honeycomb construction:
 - .1 Structural small cell, 24.5 mm maximum kraft paper 'honeycomb', weight: 36.3 kg per ream minimum, density: 16.5 kg/m³ minimum sanded to required thickness.
 - .2 Stiffened: face sheets welded, insulated core.
 - .1 Fibreglass: to CSA A101, semi-rigid RSI 2.3.
 - .2 Polyurethane: to CGSB 51-GP-21M rigid, modified poly/isocyanurate, closed cell board. Density 32 kg/m³.
 - .3 Temperature rise rated (TRR): core composition to limit temperature rise on unexposed side of door to 250°C at 60minutes. Core to be tested as part of a complete door assembly, in accordance with CAN4-S104, ASTM E 152 or NFPA 252, covering Standard Method of Tests of Door Assemblies and listed by nationally recognized testing agency having factory inspection service.
 - .4 Thermal insulation material must:
 - .1 not require being labelled as poisonous, corrosive, flammable or explosive under the Consumer Chemical and Container Regulations of the Hazardous Products Act;
 - .2 be manufactured using a process that uses chemical compounds with the minimum ozone depletion potential (ODP) available.

2.3 Adhesives

- .1 Select Adhesives which:
 - .1 do not contain volatile organic compounds in excess of 5 % by weight as measured by EPA Method 24-24A, 40 C.F.R., Part 60, Appendix A (1991), as demonstrated through calculation from records of the amounts of constituents used to make the product;
 - .2 are accompanied by detailed instructions for proper application so as to minimize health concerns and maximize performance;
 - .3 are accompanied by information describing proper disposal methods for containers.
- .2 Honeycomb cores and steel components: heat resistant, spray grade, resin reinforced neoprene/rubber (polychloroprene) based, low viscosity, contact cement.
- .3 Polystyrene and polyurethane cores: heat resistant, epoxy resin based, low viscosity, contact cement.

- .4 Lock-seam doors: fire resistant, resin reinforced polychloroprene, high viscosity, sealant/adhesive.

2.4 Primers

- .1 Touch-up prime CAN/CGSB-1.181.

2.5 Paint

- .1 Steel doors and frames shall be field painted in accordance with Sections 09911 and 09912. Weatherstripping shall be protected from paint. Finish shall be free of scratches or other blemishes.
- .2 Paint: water based, manufactured without compounds which contribute to ozone depletion in the upper atmosphere, does not contain toxic metal pigments.

2.6 Accessories

- .1 Door silencers: single stud rubber/neoprene type.
- .2 Exterior top and bottom caps: steel.
- .3 Interior top and bottom caps: steel.
- .4 Fabricate glazing stops as formed channel, minimum 16 mm height, accurately fitted, butted at corners and fastened to frame sections with counter-sunk oval head sheet metal screws.
- .5 Metallic paste filler: to manufacturer's standard.
- .6 Fire labels: metal riveted.
- .7 Glazing: as per Section 08800.
- .8 Make provisions for glazing as indicated and provide necessary glazing stops.
 - .1 Provide removable stainless steel glazing beads for dry glazing of snap-on type.
 - .2 Design exterior glazing stops to be tamperproof.

2.7 Frames Fabrication General

- .1 Fabricate frames in accordance with CSDFMA specifications.
- .2 Fabricate frames to profiles and maximum face sizes as indicated.
- .3 Exterior frames: 14 gauge minimum thermally broken type construction.
- .4 Interior frames: 14 gauge minimum welded type construction.

- .5 Blank, reinforce, drill and tap frames for mortised, template hardware, and electronic hardware using templates provided by finish hardware supplier. Reinforce frames for surface mounted hardware.
- .6 Protect mortised cutouts with steel guard boxes.
- .7 Prepare frame for door silencers, 3 for single door, 2 at head for double door.
- .8 Manufacturer's nameplates on frames and screens are not permitted.
- .9 Conceal fastenings except where exposed fastenings are indicated.
- .10 Provide factory-applied touch up primer at areas where zinc coating has been removed during fabrication.
- .11 Insulate exterior frame components with polyurethane insulation.

2.8 Frame Anchorage

- .1 Provide appropriate anchorage to floor and wall construction.
- .2 Locate each wall anchor immediately above or below each hinge reinforcement on hinge jamb and directly opposite on strike jamb.
- .3 Provide 2 anchors for rebate opening heights up to 1520 mm and 1 additional anchor for each additional 760 mm of height or fraction thereof.
- .4 Locate anchors for frames in existing openings not more than 150 mm from top and bottom of each jambs and intermediate at 660 mm o.c. maximum.

2.9 Frames: Welded Type

- .1 Welding in accordance with CSA W59.
- .2 Accurately mitre or mechanically joint frame product and securely weld on inside of profile.
- .3 Cope accurately and securely weld butt joints of mullions, transom bars, centre rails and sills.
- .4 Grind welded joints and corners to a flat plane, fill with metallic paste and sand to uniform smooth finish.
- .5 Securely attach floor anchors to inside of each jamb profile.
- .6 Weld in 2 temporary jamb spreaders per frame to maintain proper alignment during shipment.
- .7 Securely attach lead to inside of frame profile from return to jamb soffit (inclusive) on door side of frame only.

2.10 Door Fabrication General

- .1 Doors: swing type, flush, with provision for glass and/or louvre openings as indicated.
- .2 Exterior doors: honeycomb construction. Interior doors: honeycomb construction.
- .3 Fabricate doors to tack and fill edges at perimeter every 150mm. Seams: grind welded joints to a flat plane, fill with metallic paste filler and sand to a uniform smooth finish.
- .4 Doors: manufacturers' proprietary construction, tested and/or engineered as part of a fully operable assembly, including door, frame, gasketing and hardware in accordance with ASTM E 330.
- .5 Blank, reinforce, drill doors and tap for mortised, template hardware and electronic hardware.
- .6 Factory prepare holes 12.7 mm diameter and larger except mounting and through-bolt holes, on site, at time of hardware installation.
- .7 Reinforce doors where required, for surface mounted hardware. Provide flush PVC top caps to exterior doors. Provide inverted, recessed, spot welded channels to top and bottom of interior doors.
- .8 Provide factory-applied touch-up primer at areas where zinc coating has been removed during fabrication.
- .9 Provide fire labeled doors for those openings requiring fire protection ratings, as scheduled. Test such products in strict conformance with CAN4-S104, ASTM E 152 or NFPA 252 and list by nationally recognized agency having factory inspection service and construct as detailed in Follow-Up Service Procedures/Factory Inspection Manuals issued by listing agency to individual manufacturers.
- .10 Manufacturer's nameplates on doors are not permitted.

2.11 Doors: Honeycomb Core Construction

- .1 Form each face sheet for exterior doors from 16 gauge sheet steel with polyurethane core laminated under pressure to face sheets.
- .2 Form each face sheet for interior doors from 16 gauge sheet steel with temperature rise rated core laminated under pressure to face sheets.

2.12 Hollow Steel Construction

- .1 Form each face sheet for exterior doors from 16-gauge minimum sheet steel.
- .2 Form each face sheet for interior doors from 16-gauge minimum sheet steel.

- .3 Reinforce doors with vertical stiffeners, securely welded to each face sheet at 150 mm on centre maximum.
- .4 Fill voids between stiffeners of exterior doors with polyurethane core.
- .5 Fill voids between stiffeners of interior doors with temperature rise rated core.

2.13 Thermally Broken Doors and Frames

- .1 Fabricate thermally broken doors by using insulated core and separating exterior parts from interior parts with continuous interlocking thermal break.
- .2 Thermal break: rigid polyvinyl chloride extrusion conforming to CGSB 41-GP-19Ma.
- .3 Fabricate thermally broken frames separating exterior parts from interior parts with continuous interlocking thermal break.
- .4 Apply insulation.

PART 3 EXECUTION

3.1 Installation General

- .1 Install labelled steel fire rated doors and frames to NFPA 80 except where specified otherwise.
- .2 Install doors and frames to CSDFMA Installation Guide.

3.2 Frame Installation

- .1 Set frames plumb, square, level and at correct elevation.
- .2 Secure anchorages and connections to adjacent construction.
- .3 Brace frames rigidly in position while building-in. Install temporary horizontal wood spreader at third points of door opening to maintain frame width. Provide vertical support at centre of head for openings over 1200 mm wide. Remove temporary spreaders after frames are built-in.
- .4 Make allowances for deflection of structure to ensure structural loads are not transmitted to frames.
- .5 Caulk perimeter of frames between frame and adjacent material.
- .6 Maintain continuity of air barrier and vapour retarder.

3.3 Door Installation

- .1 Install doors and hardware in accordance with hardware templates and manufacturer's instructions and Section 08710 - Door Hardware.

- .2 Provide even margins between doors and jambs and doors and finished floor and thresholds as follows.
 - .1 Hinge side: 1.0 mm.
 - .2 Latch side and head: 1.5 mm.
 - .3 Finished floor, top of carpet, noncombustible sill, and thresholds: 13 mm.
- .3 Adjust operable parts for correct function.
- .4 Install louvers as indicated.

3.4 Finish Repairs

- .1 Touch up with primer finishes damaged during installation.
- .2 Fill exposed frame anchors and surfaces with imperfections with metallic paste filler and sand to a uniform smooth finish.

3.5 Glazing

- .1 Install glazing for doors in accordance with Section 08800 - Glazing.

END OF SECTION

PART 1 GENERAL

1.1 Related Sections

- .1 Section 00870 – Door and Hardware Schedule.
- .2 Section 07900 - Joints Sealers: Caulking of joints between frames and other building components.
- .3 Section 08710 - Door Hardware.
- .4 Division 16 - Electrical.

1.2 References

- .1 Aluminum Association Designation System for Aluminum Finishes-1997.
- .2 American Society for Testing and Materials (ASTM)
 - .1 ASTM E 330-97, Test Method for Structural Performance of Exterior Windows, Curtain Walls, and Doors by Uniform Static Air Pressure Difference.
- .3 Canadian General Standards Board (CGSB)
 - .1 CGSB 1.40-M89, Primer, Structural Steel, Oil Alkyd Type.
- .4 Canadian Standards Association (CSA)
 - .1 CAN/CSA-G40.21-98, Structural Quality Steels.
 - .2 CSA G164-M92, Hot Dip Galvanizing of Irregularly Shaped Articles.

1.3 Design Criteria

- .1 Design frames and doors in exterior walls to:
 - .1 Accommodate expansion and contraction within service temperature range of -35 to 35°C.
 - .2 Limit deflection of mullions to maximum 1/175th of clear span when tested to ASTM E 330 under wind load of 1.2 kpa.

1.4 Shop Drawings

- .1 Submit shop drawings in accordance with Section 01330 - Submittal Procedures.
- .2 Indicate each type of door and frame, extrusion profiles, method of assembly, section and hardware reinforcement, locations of exposed fasteners, finishes and location of manufacturer's nameplates.
- .3 Submit catalogue details for each type of door and frame illustrating profiles, dimensions and methods of assembly.

1.5 Closeout Submittals

- .1 Provide maintenance data for cleaning and maintenance of Aluminum finishes for incorporation into manual specified in Section 01780 - Closeout Submittals.

1.6 Protection

- .1 Apply temporary protective coating to finished surfaces. Remove coating after erection. Do not use coatings that will become hard to remove or leave residue.
- .2 Leave protective covering in place until final cleaning of building.

1.7 Waste Management and Disposal

- .1 Remove from site and dispose of all packaging materials at appropriate recycling facilities.
- .2 Dispose of all corrugated cardboard and plastic packaging material is to be disposed of in appropriate on-site bin for recycling in accordance with site waste management program.

PART 2 PRODUCTS

2.1 Materials

- .1 Aluminum extrusions: Aluminum Association alloy AA6063-T6 anodizing quality.
- .2 Steel reinforcement: to CAN/CSA-G40.21, grade 300 W.
- .3 Fasteners: stainless steel, finished to match adjacent material.
- .4 Weatherstrip: mohair pile.
- .5 Door bumpers: black neoprene.
- .6 Isolation coating: alkali resistant.
- .7 Glass: Factory sealed double glazing unit; 25mm overall thickness, comprised of laminated film 0.030 inches thick, clear, glass each side of air space to CAN/CGSB-12.8-M.
- .8 Sealants: to CAN/CGSB 19.13-M87.
- .9 Door panel: 1" O.D. size comp. panel. Exterior faces to match Aluminum finish.

2.2 Aluminum Doors

- .1 Acceptable material: Alumicor series 600B or Kawneer wide stile 500 series with 249-250 center rail and 200-035 bottom rail.
 - .1 Glazing stops: tamperproof type.

- .2 Hardware: see Door and Hardware Schedule, Section 00870.

2.3 Aluminum Frames

- .1 Construct insulated frames of Aluminum extrusions with minimum wall thickness of 3 mm.
- .2 Frame members 114 x 44.5 mm nominal size not thermally broken, for flush glazing.
- .3 Approved product: Alumicor 3400 Series, Kawneer 451T series, or approved equal.

2.4 Aluminum Finishes

- .1 Finish exposed surfaces of Aluminum components in accordance with Aluminum Association Designation System for Aluminum Finishes.
 - .1 Clear anodic finish.
- .2 Appearance and properties of anodized finishes designated by the Aluminum Association as Architectural Class 1, Architectural Class 2, and Protective and Decorative.

2.5 Steel Finishes

- .1 Finish steel clips and reinforcing steel with zinc coating to CSA G164.

2.6 Fabrication

- .1 Doors and frames to be by same manufacturer.
- .2 Fabricate doors and frames to profiles and maximum face sizes as shown. Provide minimum 22 mm bite for insulating glazed units.
- .3 Provide structural steel reinforcement as required.
- .4 Fit joints tightly and secure mechanically.
- .5 Conceal fastenings.
- .6 Mortise, reinforce, drill and tap doors, frames and reinforcements to receive hardware using templates provided under Section 08710 - Door Hardware.
- .7 Isolate aluminum from direct contact with dissimilar metals, concrete and masonry.

PART 3 EXECUTION

3.1 Installation

- .1 Set frames plumb, square, level at correct elevation in alignment with adjacent Work.
- .2 Anchor securely.
- .3 Install doors and hardware in accordance with hardware templates and manufacturer's instructions.
- .4 Adjust operable parts for correct function.
- .5 Make allowances for deflection of structure to ensure that structural loads are not transmitted to frames.

3.2 Glazing

- .1 Glaze Aluminum doors and frames in accordance with Section 08800 - Glazing.

3.3 Caulking

- .1 Seal joints to provide weathertight seal at outside and air, vapour seal at inside.
- .2 Apply sealant in accordance with Section 07900 - Joint Sealers. Conceal sealant within the aluminum Work except where exposed use is permitted by Contract Administrator.

END OF SECTION

Part 1 General

1.1 WORK INCLUDED

.1 The Work included under this section shall conform to the industry standard and be accepted by the local construction and trade associations.

1.2 SYSTEM DESCRIPTION

.1 Counter rolling shutter with manual unit with overhead counter balance device.

1.3 SUBMITTALS

.1 Submit shop drawings and product data to requirements of Section 01330.

.2 Indicate on shop drawings, pertinent dimensioning, general construction, component connections and details, anchorage methods, hardware locations, and installation details.

.3 Submit operation and maintenance data to requirements of Section 01330.

.4 Include descriptions of operating equipment, servicing requirements, lubrication schedules, and listing of spare parts with order numbers.

Part 2 Products

2.1 ROLLING COUNTER SHUTTER

.1 Standard of acceptance:

- Non fire rated shutters:

- Kinneer aluminum rolling counter shutter.
- Dynamic heavy duty aluminum rolling counter shutter. (Ambassador Sales).
- Cornell rolling counter shutter.
- Cookson CD10-1 Push up Counter Door.
- Amstel Manufacturing – Slimeline rolling shutters

.2 Slats: flat thickness 22 ga.

.3 Operation: manual c/w cylinder lock on interior and pin locks at each end of shutter.

.4 Hood: fully enclosed counterbalance assembly.

2.2 FINISHES

.1 Counter Shutter: clear anodized aluminum.

Part 3 Execution

3.1 INSPECTION

.1 Verify that substrate openings are ready to receive Work and opening dimensions are as indicated on shop drawings.

.2 Beginning of installation means acceptance of site conditions.

3.2 INSTALLATION

.1 Install overhead coiling doors in accordance with manufacturer's instructions.

.2 Fit, align, and adjust door assembly level and plumb; provide smooth operation.

END OF SECTION

Part 1 General

1.1 RELATED SECTIONS

- .1 Section 08800 – Glazing
- .2 Section 08950 – Translucent Glazing Units

1.2 WORK INCLUDED

- .1 The Work included under this section shall conform to the industry standard and be accepted by the local construction and trade associations.

1.3 REFERENCES

- .1 CAN3-A440-M84 - Omnibus Window Standard
- .2 CSA HA Series M - CSA Standards for Aluminum and Aluminum Alloys.

1.4 PERFORMANCE

- .1 Window components to provide for expansion and contraction caused by a cycling temperature range of 100 degrees C without causing detrimental effects to components.
- .2 Limit mullion deflection to 1/200, or flexure limit of glass with full recovery of glazing materials, whichever is less.
- .3 There shall be no uncontrolled water penetration under designed loads. Drain water entering joints, condensation occurring in glazing channels, or migrating moisture occurring within system, to exterior.

1.5 SHOP DRAWINGS AND PRODUCT DATA

- .1 Submit shop drawings and product data to requirements of Section 01300.
- .2 Indicate on shop drawings wall opening and component dimensions; wall opening tolerances required; anchorage and fasteners; affected related Work; installation requirements.

1.6 DELIVERY, STORAGE, AND HANDLING

- .1 Deliver products to site, and store and protect products on site, to requirements of Section 01610.
- .2 Accept products of this section on site in new condition and verify no damage.
- .3 Provide strippable coating to protect prefinished aluminum surfaces.

1.7 WARRANTY

- .1 Provide a three year warranty under provisions of Section 01720 and GC 13.2 of the General Conditions.
- .2 Warranty: Cover window system for failure to meet specified requirements.

Part 2 Products

2.1 MATERIALS

- .1 Extruded Aluminum: AA6063-T5 alloy, minimum 1.6 mm thick.

- .2 Sheet Aluminum: AA6063-T5 alloy, 2mm thick, bonded to 19 mm plywood where backing is required.
- .3 Concealed sheet aluminum: utility grade
- .4 Fasteners: Non magnetic, stain and corrosion resistant stainless steel to ASTM E-149.
- .5 Pressure plates & thermal separator: extruded virgin PVC thermo-barrier.
- .6 Glazing seals: extruded EPDM or neoprene
- .7 Weatherstripping: Fin-Seal polypropylene woven pile seal manufactured by Schlegel.

2.2 WINDOWS

- .1 Fixed and operating windows are to be; Alumicor Model 2200 series (or Kawneer 1602 curtain wall) at window W4 and W5, Alumicor Model 920 w/ nosing and Alumicore 1100 awning series (Kawneer 516 Isoport with 526 at vent locations) at all other locations, c/w thermal break, meeting CAN A440 performance levels for air leakage (fixed), water leakage (B7), wind load (C4), and condensation resistance (frame I71, glass I64).
- .2 Sill flashings are to be aluminum to match window framing.

2.3 GLASS AND GLAZING MATERIALS

- .1 Glass and Glazing Materials: Specified in Section 08800.

2.4 FABRICATION

- .1 Fabricate windows allowing for minimum clearances and shim spacing around perimeter of assembly, yet enabling installation.
- .2 Accurately fit and secure corners tight and rigid. Make corner joints flush, hairline, and weatherproof. Seal corner joints with sealant.
- .3 Develop drainage holes with moisture pattern to exterior.
- .4 Prepare components to receive anchor devices. Fabricate anchorage items.
- .5 Provide internal reinforcement in mullions with galvanized steel members to maintain rigidity.
- .6 Site glaze window units.

2.5 FINISHES

- .1 Exposed aluminum materials: caustic etch followed by an anodic oxide treatment to obtain an Architectural Class 1 anodic colour coating in conformance with Aluminum Association Standards. Anodized to quality AA5005-H14 alloy.
- .2 All aluminum is to be shaped first, then anodized.
- .3 Exterior Exposed Extruded Aluminum Surfaces: clear anodized
- .4 Interior Exposed Extruded Aluminum Surfaces: clear anodized
- .5 Concealed Steel Items: Galvanized in accordance with CSA G164M, to 610 g/sq m
- .6 Apply one coat of bitumen paint to concealed aluminum and steel surfaces in contact with cementitious or dissimilar materials.

Part 3 Execution

3.1 INSPECTION

- .1 Verify that surfaces are ready to receive Work and opening dimensions are as indicated on shop drawings.

- .2 Verify wall openings and adjoining air and vapour seal materials are ready to receive Work of this Section.
- .3 Beginning of installation means acceptance of substrate.

3.2 INSTALLATION

- .1 Install window frames, glass and glazing in accordance with manufacturers instructions.
- .2 Use anchorage devices to securely attach frame to structure.
- .3 Align window frame plumb and level, free of warp or twist. Maintain dimensional tolerances, aligning with adjacent Work.
- .4 Coordinate attachment and seal of air and vapour barrier materials.
- .5 Pack fibrous insulation in shim spaces at perimeter to maintain continuity of thermal barrier.
- .6 Install glass in accordance with Section 08800.
- .7 Install perimeter type sealant, backing materials, and installation requirements in accordance with Section 07900. Apply sealant to ends of sill for watertight seal.

3.3 CLEANING

- .1 Remove protective material from prefinished aluminum surfaces.
- .2 Wash down exposed surfaces using a solution of mild detergent in warm water, applied with soft, clean wiping cloths. Take care to remove dirt from corners. Wipe surfaces clean.
- .3 Remove excess sealant by moderate use of mineral spirits or other solvent acceptable to sealant manufacturer.

END OF SECTION

Part 1 - General

1.1 RELATED SECTIONS

.1 Section 08800 Glazing.

1.1 WORK INCLUDED

.1 The Work included under this section shall conform to the definitions in the "Manitoba Trade Definitions" handbook produced by the Winnipeg Construction Association.

1.2 REFERENCES

.2 CAN3-A440-M84 - Omnibus Window Standard and CAN 3-A44-M90

1.3 PERFORMANCE

.1 Window components to provide for expansion and contraction caused by a cycling temperature range of 100 degrees C without causing detrimental effects to components. Limit mullion deflection to 1/200, or flexure limit of glass with full recovery of glazing materials, whichever is less.

.2 Classification rating to CAN 3-A44-M90

| | <u>Air</u> | <u>Water</u> | <u>Wind</u> |
|-------------|------------|--------------|-------------|
| Awning | A3 | B7 | C4 |
| Casement | A3 | B6 | C3 |
| Fixed | | B7 | C4 |
| Single Hung | A3 | B7 | C5 |

.3 There shall be no uncontrolled water penetration under designed loads. Drain water entering joints, condensation occurring in glazing channels, or migrating moisture occurring within system, to exterior.

1.4 SHOP DRAWINGS AND PRODUCT DATA

.1 Submit shop drawings and product data to requirements of Section 01330.

.2 Indicate on shop drawings wall opening and component dimensions; wall opening tolerances required; anchorage and fasteners; affected related Work; installation requirements.

1.5 DELIVERY, STORAGE, AND HANDLING

.1 Deliver products to site, and store and protect products on site, to requirements of Section 01610.

.2 Accept products of this section on site in new condition and verify no damage.

1.6 WARRANTY

- .1 Provide a TWENTY (20) year Warranty for all fiberglass frame and sash components. Warranty to cover window system for failure to meet specified requirements. Warranty applies to product only with labour not included.
- .2 Provide a TEN (10) year Warranty for the failure of the air seal due to defects in the material or workmanship. Warranty applies to product only with labour not included.

Part 2 - Products

2.1 MATERIALS

- .1 All frame and sash profiles are made from Pultruded Fiberglass, having a minimum of wall thickness of 0.090" (2.3 mm), with minimum glass content of 60%. Non-structural accessory members are permitted to be in vinyl or aluminum and are identified as such.
- .2 Fasteners: Non magnetic, stain and corrosion resistant stainless steel to ASTM E-149.
- .3 Insect Screen: To CGSB 79-GP-1M and CAN3-A440-M84 Heavy Duty Classification with 18 x 14 aluminum mesh in baked enamel aluminum frame – colour to match window frame.
- .4 Sill and Flashings: aluminum to match window framing.

2.2 WEATHER-STRIPPING

- .1 Q-Lon air-seal gasket on interior with Santoprene bulb-type "rain screen" gasket on the exterior to provide weather barrier. Dust seal to be flexible PVC. Secondary seal to be dual durometer Santoprene.

2.3 WINDOWS

- .1 Standard of acceptance:
 - Duxton Windows Ltd. (Inline Fibreglass Ltd.): Sovereign series 325, narrow brick mould, low profile typical.
 - Accurate Dorwin Ltd. Windows (Omniglass Ltd.): Awning series or approved equal.

2.4 HARDWARE

- .1 Concealed Stainless Steel Hinges, E-Gard Roto Gear Operators and metal Cam are manufactured by "TRUTH Hardware" or approved equal. Hardware is installed with fasteners into patented back-up reinforcements.
- .2 All operable windows to have restricted operation, so that no object larger than a 4" diameter sphere may pass through.

2.5 GLASS

.1 All windows are glazed as specified in Section 08800. Glass thickness shall be in accordance with applicable Building Code.

2.6 GLAZING METHOD

.1 Laid-in glazing using EPDM non – shrink rubberized glass stop locked-in from the interior provides a secure and positive seal for the glass and easier after install glass servicing.

2.7 INSECT SCREEN

Roll-formed aluminum frame with friction fit corner keys. Screen mesh held in place by spline. Screens are mounted on the interior and are removable.

2.8 FABRICATION

.1 Frame and sash corners are connected with moulded reinforced polyester shearblocks and mechanically secured. All joints are factory sealed and neatly fitted together. The perimeter of open-back frames shall be filled with insulation. Fabricate windows allowing for minimum clearances and shim spacing around perimeter of assembly, yet enabling installation. Make corner joints flush, hairline, and weatherproof. Seal corner joints with sealant. Develop drainage holes with moisture pattern to exterior.

2.9 FINISHES

- .1 The exposed surfaces to have 10 year warranty against fading, peeling or cracking are:
- Isocyanate-free 2 part Polymer Enamel with a minimum dry film thickness of 1.5 mils with a medium gloss of 25-55. Finish shall resist chipping, blistering, chalking discoloration and aging under all atmospheric conditions. Conforms to AAMA 603 and 613 Organic Coatings.
- .2 Concealed Steel Items: Galvanized in accordance with CSA G164M
- .3 Colours: full exterior color from premium custom colors.
- .4 Include Lexan as detailed on all windows, as detailed and Section 08800.

Part 3 - Execution

3.1 INSPECTION

- .1 Verify that surfaces are ready to receive Work and opening dimensions are as indicated on shop drawings.
- .2 Verify wall openings and adjoining air and vapour seal materials are ready to receive Work of this Section.
- .3 Beginning of installation means acceptance of substrate.

3.2 INSTALLATION

- .1 Installation shall be performed by experienced installers in accordance with manufacturer instructions and CSA A-440.4 Standards. Window shall be plumb and square after installation is complete and sealed to both interior and exterior wall with a high quality sealant around the perimeter of the frame. If perimeter cavity is to be foamed, additional anchorage may be required to prevent bowing. It shall be the responsibility of the installers to make all necessary final adjustments to ensure normal and smooth operation.
 - .2 Align window frame plumb and level, free of warp or twist. Maintain dimensional tolerances, aligning with adjacent Work.
 - .3 Coordinate attachment and seal of air and vapour barrier materials.
 - .4 Pack fibrous insulation in shim spaces at perimeter to maintain continuity of thermal barrier.
 - .5 Install glass in accordance with Section 08800
 - .6 Install perimeter type sealant, backing materials, and installation requirements in accordance with Section 07900. Apply sealant to ends of sill for watertight seal.
- 3.3 MAINTENANCE
- .1 Occasional wash of glass and frame components with non-abrasive detergent is recommended

END OF SECTION

PART 1 GENERAL

.1 Related Sections

- .1 Section 00870 – Door and Hardware Schedule
- .2 Section 06201 – Finish Carpentry
- .3 Section 08110 - Steel Doors and Frames
- .4 Section 08120 – Aluminum Doors and Frames
- .5 Division 16: Electrical wiring for magnetic strikes, electric releases and electric locks.

.2 References

- .1 Standard hardware location dimensions in accordance with Canadian Metric Guide for Steel Doors and Frames (Modular Construction) prepared by Canadian Steel Door and Frame Manufacturers' Association.
- .2 Canadian General Standards Board (CGSB)
 - .1 CAN/CGSB-69.17-M86, Bored and Pre-assembled Locks and Latches.
 - .2 CAN/CGSB-69.18-M90 / ANSI/BHMA A156.1-1981, Butts and Hinges.
 - .3 CAN/CGSB-69.19-93 / ANSI/BHMA A156.3-1984, Exit Devices.
 - .4 CAN/CGSB-69.20-M90 / ANSI/BHMA A156.4-1986, Door Controls (Closers).
 - .5 CAN/CGSB-69.21-M90 / ANSI/BHMA A156.5-1984, Auxiliary Locks and Associated Products.
 - .6 CAN/CGSB-69.24-M90 / ANSI/BHMA A156.8-1982, Door Controls - Overhead Holders.
 - .7 CAN/CGSB-69.26-[96 / ANSI/BHMA A156.10-1985, Power-operated Pedestrian Doors.
 - .8 CAN/CGSB-69.29-93 / ANSI/BHMA A156.13-1980, Mortise Locks and Latches.
 - .9 CAN/CGSB-69.30-93 / ANSI/BHMA A156.14-1985, Sliding and Folding Door Hardware.
 - .10 CAN/CGSB-69.31-M89 / ANSI/BHMA A156.15-1981, Closer/Holder Release Device.
 - .11 CAN/CGSB-69.32-M90 / ANSI/BHMA A156.16-1981, Auxiliary Hardware.
 - .12 CAN/CGSB-69.33-M90 / ANSI/BHMA A156.17-1987, Self-closing Hinges and Pivots.

- .13 CAN/CGSB-69.34-93 / ANSI/BHMA A156.18-1984, Materials and Finishes.
- .14 CAN/CGSB-69.35-M89 / ANSI/BHMA A156.19-1984, Power Assist and Low Energy Power Operated Doors.
- .15 CAN/CGSB-69.36-M90 / ANSI/BHMA A156.20-1984, Strap and Tee Hinges and Hasps.

.3 Requirements Regulatory Agencies

- .1 Hardware for doors in fire separations and exit doors certified by a Canadian Certification Organization accredited by Standards Council of Canada.

.4 Hardware List

- .1 Submit Contract hardware list in accordance with Section 01330 - Submittal Procedures.
- .2 Indicate specified hardware, including make, model, material, function, size, finish and other pertinent information.

.5 Closeout Submittals

- .1 Provide operation and maintenance data for door closers, locksets, door holders and fire exit hardware for incorporation into manual specified in Section 01780 - Closeout Submittals.
- .2 Instruct maintenance staff regarding proper care, cleaning, and general maintenance on door hardware.

.6 Extra Materials

- .1 Provide maintenance materials in accordance with Section 01780 - Closeout Submittals.
- .2 Supply two sets of wrenches for door closers, locksets, and fire exit hardware.

.7 Delivery and Storage

- .1 Deliver, store, handle and protect materials in accordance with Section 01610 - Basic Product Requirements.
- .2 Store finishing hardware in locked, clean and dry area.
- .3 Package each item of hardware including fastenings, separately or in like groups of hardware, label each package as to item definition and location.

.8 Waste Disposal and Management

- .1 Remove from site and dispose of all packaging materials at appropriate recycling facilities.

PART 2 PRODUCTS

.1 Hardware Items

- .1 Only door locksets and latch sets listed on CGSB Qualified Products List are acceptable for use on this project.
- .2 Use one manufacturer's products only for all similar items.

.2 Door Hardware

- .1 Locks and latches:
 - .1 Bored and pre-assembled locks and latches: to CAN/CGSB-69.17, as stated in Hardware Schedule.
 - .2 Lever handles: plain design.
 - .3 Normal strikes: box type, lip projection not beyond jamb.
 - .4 Cylinders: key into keying system as instructed by Contract Administrator.
 - .5 Finished: as specified in hardware schedule.
- .2 Butts and hinges:
 - .1 Butts and hinges: to CAN/CGSB-69.18, designated by letter A and numeral identifiers, followed by size and finish, listed in Hardware Schedule.
- .3 Exit devices: to CAN/CGSB-69.19, type modern design.
- .4 Door Closers and Accessories:
 - .1 Door controls (closers): to CAN/CGSB-69.20, designated by letter C and numeral identifiers listed in Hardware Schedule, in accordance with CAN/CGSB-69.20, table A1.
- .5 Door Operators:
 - .1 Power-operated pedestrian doors: to CAN/CGSB-69.26.
 - .2 Power assist and low energy power operated doors: to CAN/CGSB-69.35.
- .6 Auxiliary locks and associated products: to CAN/CGSB-69.21, designated by letter E and numeral identifiers listed in Hardware Schedule.
- .7 Smoke Seal:
 - .1 Neoprene bulb, fire resistant, adhesive backed, set in door frame rabbet.

.3 Fastenings

- .1 Supply screws, bolts, expansion shields and other fastening devices required for satisfactory installation and operation of hardware.
- .2 Exposed fastening devices to match finish of hardware.
- .3 Where pull is scheduled on one side of door and push plate on other side, supply fastening devices, and install so pull can be secured through door from reverse side. Install push plate to cover fasteners.
- .4 Use fasteners compatible with material through which they pass.

.4 Keying

- .1 Doors, cabinet locks to be keyed differently, master keyed as noted in Hardware Schedule. Prepare detailed keying schedule in conjunction with Contract Administrator.
- .2 Provide keys in duplicate for every lock in this Contract.
- .3 Provide three master keys for each MK or GMK group.
- .4 Stamp keying code numbers on keys and cylinders.
- .5 Provide construction cores.
- .6 Provide all permanent cores and keys to Contract Administrator.

PART 3 EXECUTION

.1 Installation Instructions

- .1 Furnish metal door and frame manufacturers with complete instructions and templates for preparation of their Work to receive hardware.
- .2 Furnish manufacturers' instructions for proper installation of each hardware component.
- .3 Install hardware to standard hardware location dimensions in accordance with Canadian Metric Guide for Steel Doors and Frames (Modular Construction) prepared by Canadian Steel Door and Frame Manufacturers' Association.
- .4 Where door stop contacts door pulls, mount stop to strike bottom of pull.
- .5 Install key control cabinet.
- .6 Remove construction cores when directed by Contract Administrator; install permanent cores and check operation of all locks.

.2 Mounting Heights

- .1 Maintain the following mounting heights above finished floor for door from finished floor to center line of hardware item:
 - .1 Locksets 900
 - .2 Push/Pulls 1050
 - .3 Deadlocks 1070
 - .4 Panic Devices 900
 - .5 Auto Openers 900

- .3 Setup Keying System and Cabinet**
 - .1 Set up key control system with file key tags, duplicate key tags, numerical index, alphabetical index and key change index, control book and key receipt cards.
 - .2 Turn over keys to Contract Administrator.

END OF SECTION

PART 1 GENERAL

1.1 Related Sections

- .1 08520 – Aluminum Windows.
- .2 08620 - Fibreglass Windows.

1.2 References

- .1 American National Standards Institute (ANSI)
 - .1 ANSI/ASTM E 330-97e1, Test Method for Structural Performance of Exterior Windows, Curtain Walls and Doors by Uniform Static Air Pressure Difference.
- .2 American Society for Testing and Materials (ASTM)
 - .1 ASTM C 542-94, Specification for Lock-Strip Gaskets.
 - .2 ASTM E 84-99, Test Method for Surface Burning Characteristics of Building Materials.
 - .3 ASTM F 1233-98, Test Method for Security Glazing Materials and Systems.
- .3 Canadian Door and Window Manufacturers, Certification Program.
- .4 Canadian General Standards Board (CGSB)
 - .1 CAN/CGSB-12.1-M90, Tempered or Laminated Safety Glass.
 - .2 CAN/CGSB-12.2-M91, Flat, Clear Sheet Glass.
 - .3 CAN/CGSB-12.3-M91, Flat, Clear Float Glass.
 - .4 CAN/CGSB-12.8-97, Insulating Glass Units.
 - .5 CAN/CGSB-12.10-M76, Glass, Light and Heat Reflecting.
 - .6 CAN/CGSB-12.11-M90, Wired Safety Glass.
- .5 Canadian Standards Association (CSA)
 - .1 CSA A440.2-98, Energy Performance Evaluation of Windows and Sliding Glass Doors.
- .6 Environmental Choice Program (ECP)
 - .1 ECP-45-92, Sealants and Caulking.
- .7 Flat Glass Manufacturers Association (FGMA), Glazing Manual
- .8 Laminators Safety Glass Association, Standards Manual.

1.3 Performance Requirements

- .1 Provide continuity of building enclosure vapour and air barrier using glass and glazing materials as follow:
 - .1 Utilize inner light of multiple light sealed units for continuity of air and vapour seal.
- .2 Size glass to withstand wind loads, dead loads and positive and negative live loads as measured in accordance with ANSI/ASTM E 330.
- .3 Limit glass deflection to 1/200 with full recovery of glazing materials.

1.4 Shop Drawings

- .1 Submit shop drawings in accordance with Section 01330 - Submittal Procedures.

1.5 Closeout Submittals

- .1 Provide maintenance data including cleaning instructions for incorporation into manual specified in Section 01780 - Closeout Submittals.

1.6 Quality Assurance

- .1 Perform Work in accordance with FGMA Glazing Manual for glazing installation methods.
- .2 Provide testing of glass under provisions of Section 01450 - Quality Control.

1.7 Environmental Requirements

- .1 Install glazing when ambient temperature is 10 °C minimum. Maintain ventilated environment for 24 hours after application.
- .2 Maintain minimum ambient temperature before, during and 24 hours after installation of glazing compounds.

1.8 Waste Management and Disposal

- .1 Divert metal cut-offs from landfill by disposal into on-site Metal recycling bin or at nearest metal recycling facility.
- .2 Divert uninstalled materials for reuse at nearest used building materials facility or similar type facility.
- .3 Divert unused caulking and sealant materials from landfill through disposal at special wastes depot.

1.9 Packaging Materials

- .1 Remove from site and dispose of all packaging at appropriate recycling facilities.

- .2 Dispose of all corrugated cardboard and plastic packaging material in appropriate on-site bin for recycling in accordance with site waste management program.

PART 2 PRODUCTS

2.1 Materials:

- .1 **Type A: Float Glass for interior units:** CAN2-12.3M; glazing quality, thickness to suit opening size thickness and shall be in accordance with applicable Building Code, clear.
- .2 **Type B: Safety Glass for entrances and as specified:** CAN2-12.1M; Type 2 - Tempered, Class B - Float, thickness to suit opening size thickness and shall be in accordance with applicable Building Code., clear.
- .3 **Type D: Insulated Glass Units at entrances:** CAN2-12.8M; double pane, outer pane of Type B safety glass, inner pane of Type B safety glass, thickness to suit opening size and thickness shall be in accordance with applicable Building Code., interpane space of a full 13 mm, purged dry and hermetically sealed, (22 mm) insulating glass units with Argon and Super Spacer with R-value of 4.2 (cog) and SHGC of .52.
- .4 **Type E: Insulated Glass Units for all exterior south and west facing windows:** CAN2-12.8M; double pane, outer and inner pane of Type A float glass, glass thickness to suit opening size and in accordance with applicable Building Code, full 13mm interpane space purged dry and hermetically sealed for total unit thickness of 22 mm. Include Low-e coating on #2 surface, warm edge spacer (Super Spacer or XL bar), and Argon fill for visible light transmission of 70% min., minimum R-value of 4.2 (cog) min. and SHGC of 0.44 max.
- .5 **Type F: Insulated Glass Units for all exterior north and east facing windows:** CAN2-12.8M; double pane, outer and inner pane of Type A float glass, glass thickness to suit opening size and in accordance with applicable Building Code, full 13mm interpane space purged dry and hermetically sealed for total unit thickness of 22 mm. Include Low-e coating on #2 surface, warm edge spacer (Super Spacer or XL bar), and Argon fill for visible light transmission of 74% min., minimum R-value of 4.2 (cog) min. and SHGC of 0.62 max.
- .6 **Type H: Polycarbonate sheet at all exterior locations:** 6mm thick at spans up to 600mm, 9.5mm thick at spans up to 900mm, 13mm thick at spans up to 1200mm, clear, MR-10 Lexan, Macrolon AR by Shelffield Plastics, or equal, – see architectural details.

2.2 Accessories

- .1 Setting blocks: Neoprene, 80-90 Shore A durometer hardness to ASTM D 2240, to suit glazing method, glass light weight and area.

- .2 Spacer shims: Neoprene, 50-60 Shore A durometer hardness to ASTM D 2240, 75 mm long x one half height of glazing stop x thickness to suit application. Self adhesive on one face.
- .3 Glazing tape:
 - .1 Preformed butyl compound with integral resilient tube spacing device, 10-15 Shore A durometer hardness to ASTM D 2240; coiled on release paper; size to suit application; black colour.
 - .2 Closed cell polyvinyl chloride foam, coiled on release paper over adhesive on two sides, maximum water absorption by volume 2 %, designed for compression of 25 %, to effect an air and vapour seal; size to suit application.
- .4 Glazing splines: resilient silicone, extruded shape to suit glazing channel retaining slot, colour as selected.
- .5 Glazing clips: manufacturer's standard type.
- .6 Lock-strip gaskets: to ASTM C 542.
- .7 Mirror attachment accessories:
 - .1 Stainless steel clips.

PART 3 EXECUTION

3.1 Examination

- .1 Verify that openings for glazing are correctly sized and within tolerance.
- .2 Verify that surfaces of glazing channels or recesses are clean, free of obstructions, and ready to receive glazing.

3.2 Preparation

- .1 Clean contact surfaces with solvent and wipe dry.
- .2 Seal porous glazing channels or recesses with substrate compatible primer or sealer.
- .3 Prime surfaces scheduled to receive sealant.

3.3 Installation: Exterior -Dry Method (Preformed Glazing)

- .1 Cut glazing tape or spline to length; install on glazing light. Seal corners by butting tape or spline and sealing junctions with sealant.
- .2 Place setting blocks at 1/4 points, with edge block maximum 150 mm from corners.

- .3 Rest glazing on setting blocks and push against fixed stop with sufficient pressure to attain full contact.
- .4 Install removable stops without displacing glazing tape or spline. Exert pressure for full continuous contact.
- .5 Trim protruding tape edge.

3.4 Installation: Interior - Dry Method (Tape and Tape)

- .1 Cut glazing tape to length and set against permanent stops, projecting 1.6 mm above sight line.
- .2 Place setting blocks at 1/4 points, with edge maximum 150 mm from corners.
- .3 Rest glazing on setting blocks and push against tape for full contact at perimeter of light or unit.
- .4 Place glazing tape on free perimeter of glazing in same manner described.
- .5 Install removable stop without displacement of tape. Exert pressure on tape for full continuous contact.
- .6 Knife trim protruding tape.

3.5 Installation: Mirrors

- .1 Set mirrors in accordance with manufacturer's instructions to be tamperproof.
- .2 Place plumb and level.

3.6 Cleaning

- .1 Remove glazing materials from finish surfaces.
- .2 Remove labels after Work is complete.
- .3 Clean glass and mirrors.

3.7 Protection of Finished Work

- .1 After installation, mark light with an "X" by using removable plastic tape or paste. Do not mark heat absorbing or reflective glass units.

END OF SECTION

PART 1 GENERAL

1.1 SUMMARY

- .1 Section Includes:
Glass-Based Light Diffusing Insulating Glazing Units (TGUs)
- .2 Related Sections:
 - .1 Section 08520 - Aluminum Windows
 - .2 Section 08620 – Fiberglass Windows
 - .3 Section 08800 - Glazing

1.2 SUBMITTALS

- .1 Product Data: Submit manufacturer's technical data for TGU materials, including installation and maintenance instructions.

1.3 QUALITY ASSURANCE

- .1 Glazing Standards: Comply with recommendations of Flat Glass Marketing Association (FGMA) "Glazing Manual" and "Sealant Manual" except where more stringent requirements are indicated. Refer to those publications for definitions of glass and glazing terms not otherwise defined in this section or other referenced standards.
- .2 Glazing Standards: Comply with recommendations of Sealed Insulating Glass Manufacturers Association (SIGMA) except where more stringent requirements are indicated.
- .3 Industry standards for glass: ASTM C 1036-85 "Standard Specification for Flat Glass", ASTM C 1048-87 "Standard Specification Heated Flat Glass – Kind HS, Kind FT Coated and Uncoated Glass" .
- .4 16 CFR 1201 "Safety Standard for Architectural Glazing Materials".
- .5 Single Source Responsibility for Glass: To ensure consistent quality of appearance and performance, provide glass produced by a single primary manufacturer for each kind and condition of glass indicated and composed of primary glass obtained from a single source for each type and class required.

1.4 MULLION/FRAMING DESIGN

- .1 Provide framing system with minimum 1/4" diameter or slot design of 3/16" x 3/8" vent/drainage holes for each TGU.
- .2 Keep glazing rebate clear of protrusions except glass support setting blocks and spacer shims. Setting blocks shall be designed or positioned to allow water passage to weep or vent holes.
- .3 Provide glazing stops with plane, continuous and uniform supports for surfaces of TGU.
- .4 Frame joints shall be adequately sealed to prevent water and air infiltration from exterior and interior.
- .5 Glazing installation must ensure that intra-frame cavity is drained and vented to outside as per TGU manufacturer's recommendations.

.6 Edge clamping pressure must be sufficient to achieve an air and watertight seal but should not exceed 10 lbs. per linear inch to avoid risk of unit damage.

.7 Structurally design frame members to withstand wind loads and dead loads transferred by TGU. Frame members shall not deflect more than lesser of length/175 or 3/4" at full design load. Support edges of TGU to resist wind and other loads. Minimum bite on glass edge shall be 13 mm (1/2") to firmly support TGU when exposed to static and dynamic loads.

.8 Height of glass stops may vary depending on area of TGU, external forces and functions. Manufacturers of glass, framing, sealed units & sealants as well as architectural specification should be consulted. Many unit assembly sealants must be shielded from direct sunlight, depending upon glass specified. A stop height of approximately 19 mm (3/4") is commonly used. Minimum bite on glass edge shall be 13 mm (1/2") to firmly support insulating glass unit when exposed to static and dynamic loads.

.9 Use structurally adequate thermally broken frames with Solera® TGU to minimize condensation on interior surfaces in cold weather. Thermal stress on TGU is reduced when thermally broken frames are used.

.10 Seal Solera® TGU to interior to create complete air barrier and prevent migration of air and moisture from entering glazing cavity from building interior.

.11 The 'intra-frame cavity', located between Solera® TGU and framing system must be vented and self-draining to limit build up of high humidity air and ensure air pressure equilibrium as per TGU manufacturer's recommendations.

.12 Glazing clearances must be sufficient to accommodate manufacturing tolerances in TGU size and overall thickness and to ensure that TGU "floats" within retaining system as per TGU manufacturer's recommendations.

1.5 DELIVERY, STORAGE, AND HANDLING

.Protect TGU during delivery, storage and handling to comply with manufacturer's directions and as required to prevent edge damage to glass.

1.6 PROJECT CONDITIONS

A. Environmental Conditions: Do not proceed with glazing when ambient and substrate temperature conditions are outside limits permitted by glazing material manufacturer or when joint substrates are wet due to rain, frost, condensation or other causes.

1.7 WARRANTY

B. Submit TGU manufacturer's warranty against defects and workmanship for a period of five (5) years from date of purchase, including:

Discoloration of honeycomb or veil material by more than 2.0 ΔE (ASTM D 2244-93 (Reapproved 2000));

Loss of light transmittance to less than 3%, determined according to manufacturer's technical data;

Seal leakage;

Substantial deterioration of insulating insert;

Crushing or corrosion of spacer;

Buildup of visible internal moisture.

PART 2 PRODUCTS

2.1 ACCEPTABLE TRANSLUCENT GLAZING UNIT MANUFACTURERS

Advanced Glazings Limited, P.O. Box 1460 Station "A" , Sydney, N.S. Canada, B1P 6R7, phone (902)794-2899, email info@advancedglazings.com

2.2 TRANSLUCENT GLAZING UNITS (TGU)

.1 TGU Design and Appearance:

- .1 The Translucent Glazing Unit shall be of a design such as to present a monolithic glass section without visible internal framing, support or other solid member inside of the perimeter spacer. The ability to use of any type or manufacture of architectural flat glass shall enable the visual integration of translucent surfaces with those of nearby vision glass as well as ensuring that the appearance of the translucent glazing surfaces does not deteriorate over the life of the building. The employment of separate technologies for thermal insulation and light diffusion shall be such as to ensure that different thermal insulation specifications do not affect light transmission.

.2 TGU Description:

- .1 Air filled preassembled units consisting of:
 - .1 Two lites of glass;
 - .2 Proprietary honeycomb transparent insulation core aligned perpendicular to glazing, for TGU thermal insulation;
 - .3 Translucent veils attached to both sides of honeycomb cell core adjacent to glass surfaces;
 - .4 Continuous perimeter metal spacer bar separated from glass surfaces with foam tape;
 - .5 Glass lites connected together with spacer bar using structural silicone sealant.
 - .6 Airspace within TGU filled with air pressure equalized to atmospheric pressure with stainless steel capillary pressure equalization (vent) tube located at top right corner of TGU, positioned with tube opening pointing downward (as viewed from building interior).
 - .7 Glazing unit shall not contain in excess of .01 parts per million by weight each of Volatile Organic Compounds, asbestos, resorcinol-formaldehyde, pheono-resorcinol formaldehyde, urea formaldehyde, CFC, HFC, HCFC, Halon, Benzene, Cadmium (and compounds, Carbon tetrachloride, Cyanide (and compounds) Toluene, Xylenes, Lead. 1,1,1,Trichlorethane, Trichlorethylene, MEK, MIK and Ultra-violet inhibitors.
- .2 Overall thickness and size:
 - .1 Minimum thickness: 2.5" plus glass lites.
 - .2 Maximum overall size, edge of glass: 60" x 168"

- .3 Frame compatibility:
 - .1 Solera "T".
- .4 TGU performance:
 - .1 Thermal insulation (U-value): 0.20
 - .2 Daylight transmittance: 73%.
 - .3 Solar heat gain coefficient (no shade): SHGC= 0.95 x selected visible light transmittance level.
 - .4 Maximum color shift: $2\Delta E$ over 5 years.
 - .5 Flame spread (ASTM E 84): 5.
 - .6 Smoke developed (ASTM E 84): 10.
 - .7 Spacer resistance to crushing: 500 lbs/lineal Ft.
- .3 Glass:
 - .1 Exterior lite: clear 6mm as manufactured by:
 - .1 PPG
 - .2 Pilkington
 - .3 or approved equal
 - .2 Interior lite: 6mm tempered as manufactured by:
 - .1 PPG
 - .2 Pilkington
 - .3 or approved equal
- .4 Veil:
 - .1 Veil to be decided by City.
- .5 Spacer bar:
 - .1 Extruded Aluminum. Solera-T
- .6 Foam tape: neoprene.
- .7 Capillary pressure equalization (vent) tube: stainless steel, diameter to allow for pressure equalization while also preventing uptake of particulate matter.

2.3 ELASTOMERIC GLAZING SEALANTS AND PREFORMED GLAZING TAPES

- .1 General: Provide products of type indicated and complying with following requirements:
 - .1 Glazing sealants and glazing tapes: to glazing frame manufacturer's standards.
 - .2 Compatibility: Select glazing sealants and tapes of proven compatibility with other materials with which they will come into contact, including glass products, seals of insulating glass units, and glazing channel substrates,

under conditions of installation and service, as demonstrated by testing and field experience.

- .3 Suitability: Comply with recommendations of sealant and glass manufacturers for selection of glazing sealants and tapes which have performance characteristics suitable for applications indicated and conditions at time of installation.
- .4 Elastomeric Sealant Standard: Provide manufacturer's standard chemically curing, elastomeric sealant of base polymer indicated which complies with ASTM C 920 requirements, including those for Type, Grade, Class and Uses.
- .5 Colors: Provide color of exposed sealants indicated or, if not otherwise indicated, as selected by City's Representative from manufacturer's standard colors.

2.4 MISCELLANEOUS GLAZING MATERIALS

- .1 Compatibility: Provide materials with proven record of compatibility with surfaces contacted in installation.
- .2 Cleaners, Primers and Sealers: Type recommended by sealant or gasket manufacturer.
- .3 Setting Blocks, Spacers: as designed and supplied by TGU manufacturer.

PART 3 EXECUTION

3.1 EXAMINATION:

.1 Require Glazier to inspect Work of glass framing erector for compliance with manufacturing and installation tolerances, including those for size, squareness, offsets at corners; for presence and functioning of weep system; for existence of minimum required face or edge clearances; and for effective sealing of joinery. Obtain Glazier's written report, listing conditions detrimental to performance of glazing Work. Do not allow glazing Work to proceed until unsatisfactory conditions have been corrected.

3.2 PREPARATION:

.1 Clean glazing channels and other framing members to receive glass, immediately before glazing. Remove coatings, which are not firmly bonded to substrates. Remove lacquer from metal surfaces where elastomeric sealants are indicated for use.

3.3 GLAZING, GENERAL

- .1 Keep pressure equalization (vent) tube free of obstructions that limit free flow of air in and out of vent tube.
- .2 Comply with combined printed recommendations of glass manufacturers, of manufacturers of sealants, gaskets and other glazing materials, except where more stringent requirements are indicated, including those of referenced glazing standards.

.3 Protect glass from edge damage during handling and installation; use a rolling block in rotating glass units to prevent damage to glass corners. Do not impact glass with metal framing. Use suction cups to shift TGU within openings; do not raise or drift glass with a pry bar. Rotate glass with flares or bevels along one horizontal edge which would occur in vicinity of setting blocks so that these are located at top of opening. Remove from project and dispose of glass units with edge damage or other imperfections of kind that, when installed, weakens glass and impairs performance and appearance.

.4 Apply primers to joint surfaces where required for adhesion of sealants, as determined by preconstruction sealant-substrate testing.

.5 Anchor components securely in place in manner indicated. Shim and allow for movement resulting from changes in thermal conditions. Provide separators and isolators to prevent corrosion, electrolytic deterioration, and "freeze-up" of moving joints.

.6 Glazing: Inspect glass and framing for compliance with manufacturing and installation tolerances, including size, squareness, and offsets at corners; for existence of minimum face or edge clearances; and for effective sealing of joinery.

.1 Avoid point loading of glass. Do not proceed with glazing Work until unsatisfactory conditions have been corrected. Do not field-cut glass.

.2 Field-Glazed Structural Silicone Glazing Work: Clean frames and glass surfaces with an approved solvent. Prime surfaces and apply structural sealant in accordance with manufacturer's recommendations. Clean excess structural sealant. Mechanically hold glass firmly in place until sealant is sufficiently cured. Install compressible backer rods in joint before applying weatherseal sealant.

3.4 GLAZING

.1 Install setting blocks of proper size in sill rabbet, located one quarter of glass width from each corner, but with edge nearest corner not closer than 6" from corner, unless otherwise required.

.2 Provide spacers inside and out, of correct size and spacing to preserve required face clearances, for glass sizes larger than 50 united inches (length plus height), except where gaskets or glazing tapes with continuous spacer rods are used for glazing. Provide 1/8" minimum bite of spacers on glass and use thickness equal to sealant width, except with sealant tape use thickness slightly less than final compressed thickness of tape.

.3 Provide edge blocking to comply with requirements of referenced glazing standard, except where otherwise required by glass unit manufacturer. Set units of glass in each series with uniformity of pattern, draw, bow and similar characteristics.

3.5 PROTECTION AND CLEANING

.1 Remove nonpermanent labels and clean surfaces.

.2 Protect glass from contact with contaminating substances resulting from construction operations. If, despite such protection, contaminating substances do come into contact with glass, remove immediately by method recommended by glass manufacturer.

.3 Examine glass surfaces adjacent to or below exterior concrete and other masonry surfaces at frequent intervals during construction, but not less often than once a month, for build-up of dirt, scum, alkali deposits or staining. When examination reveals presence of these forms of residue, remove by method recommended by glass manufacturer.

.4 Remove and replace glass which is broken, chipped, cracked, abraded or damaged in other ways during construction period, including natural causes, accidents and vandalism.

END OF SECTION

PART 1 GENERAL

1.1 Related Sections

- .1 Section 00301: Separate Prices
- .2 Section 07190: Vapour and Air Barriers
- .3 Section 07620: Sheet Metal Flashings and Trim

1.2 References

- .1 Portland Cement Plaster Stucco Manual.

1.3 Samples

- .1 Submit 610 x 610 mm samples illustrating varying surface finishes and colours.

1.4 Environmental Requirements

- .1 Do not apply stucco when substrate or ambient air temperature is less than 10 degrees C.
- .2 Maintain minimum ambient temperature of 10 degrees C during and after installation of stucco.

PART 2 PRODUCTS

2.1 Types

- .1 STUCCO TYPE A: Knock Down light dash stucco texture

2.2 Materials

- .1 Cement: CAN3-A5M, Portland Type, Symbol 10, White or grey as selected by Architect.
- .2 Lime: hydrated finishing lime conforming with current CSA Specification.
- .3 Sand: CSA A.82.57 - 1954; clean, coarse, sharp, well screened.
- .4 Water: Clean, fresh, potable and free of mineral or organic matter which can affect stucco.
- .5 Imasco color: Stucco color "A" to be 1 jar color to 6 bags Premix as identified in Imasco color chart. Stucco color "B" to be 6 jars color to 6 bags Premix as identified in Imasco color chart.

2.3 Accessories

- .1 Sheet Air Barrier/Building Paper: DuPont Tyvek Housewrap as per Section 07190.
- .2 Wire Mesh Reinforcement: 38 x 38 mm hot dipped galvanized steel 0.6 mm wire, woven mesh, self furring type.
- .3 Corner Beads, Base Screeds, Casing Beads, Stops, Control Joints: Formed steel, minimum 0.5mm thick, expanded metal flanges, hot dipped galv. finish; thickness to suit stucco thickness.
- .4 Flashings: As specified in Section 07620.
- .5 Anchorages: Nails, staples, or other approved metal supports, of type and size to suit application, hot dipped galvanized, to rigidly secure reinforcement and associated metal accessories in place.

2.4 Mix Design

- .1 Develop stucco mix design in accordance with CSA A82.30M.
- .2 Mix materials dry, to uniform color and consistency, before adding water unless manufacturers written recommendation states otherwise.
- .3 Protect mixtures from frost, contamination, and evaporation.
- .4 Do not retemper mixes after initial set has occurred.

PART 3 EXECUTION

3.1 Examination

- .1 Verify that surfaces and site conditions are ready to receive Work.
- .2 Grounds and Blocking: Verify items within walls for other sections of Work have been installed.
- .3 Mechanical and Electrical: Verify services within walls have been tested and approved.
- .4 Beginning of installation means acceptance of existing conditions.

3.2 Preparation

- .1 Protect surfaces near the Work of this Section from damage or disfiguration.

3.3 Installation – Reinforcement

- .1 Wrap exterior of structure with sheet air barrier/building paper to areas indicated on the drawings. Secure to substrate with staples as sheet barrier is being unrolled to prevent billowing. Lap horizontal and vertical joints minimum 300 mm. At openings in

the exterior wall cut an 'X' through the sheet barrier and return the sheet barrier to the inside framing.

.2 At external and internal corners, install a 150 mm wide strip of expanded metal lath bent to conform to angle of corner, with equal legs each side of corner.

.3 Install reinforcement over underlayment, with long dimension horizontal, lapping joints not less than 25 mm, lapping upper courses over lower courses. and lapping ends.

.4 Install casing beads, control joints, stops and screeds at locations as shown on drawings. Install straight, plumb, level, rigid and in the proper plane. Use full length pieces to minimize joints. Fit lengths together without gaps, accurately align and rigidly secure each side of joints. Mitre and fit corners accurately, without rough edges.

3.4 Stucco Application

.1 Apply scratch coat to a nominal thickness of 9 mm with sufficient material and force to form good key. Moist cure.

.2 Apply brown coat to nominal thickness of 9mm, bring out grounds, straighten to true surface, float and compact. Moist cure.

.3 After curing, dampen brown coat prior to applying finish coat.

.4 Apply float finish coat to a nominal thickness of 6 mm. Float/trowel to reach desired surface texture. Avoid excessive working of surface. Delay toweling as long as possible to avoid drawing excess fines to surface.

.5 Moist cure finish coat for minimum period of 48 hours.

3.5 Tolerances

.1 Maximum variation from true flatness: 3 mm in 3 m.

END OF SECTION

PART 1 GENERAL

.1 Related Work Specified Elsewhere

- .1 Section 06100 – Rough Carpentry
- .2 Section 06201 – Finish Carpentry
- .3 Section 07190 – Vapour and Air Barriers

.2 References

- .1 Aluminum Association
 - .1 Designation for Aluminum Finishes-1997.
- .2 American Society for Testing and Materials (ASTM)
 - .1 ASTM C 36-95, Specification for Gypsum Wallboard.
 - .2 ASTM C 79-94, Specification for Gypsum Sheathing Board.
 - .3 ASTM C 442-92, Specification for Gypsum Backing Board and Coreboard.
 - .4 ASTM C 475-94, Specification for Joint Compound and Joint Tape for Finishing Gypsum Board.
 - .5 ASTM C 514-94, Specification for Nails for the Application of Gypsum Board.
 - .6 ASTM C 557-93a, Specification for Adhesives for Fastening Gypsum Wallboard to Wood Framing.
 - .7 ASTM C 630-93, Specification for Water-Resistant Gypsum Backing Board.
 - .8 ASTM C 840-95, Specification for Application and Finishing of Gypsum Board.
 - .9 ASTM C 954-93, Specification for Steel Drill Screws for the Application of Gypsum Board.
 - .10 ASTM C 1002-93, Specification for Steel Drill Screws for the Application of Gypsum Board or Metal Plaster Bases.
 - .11 ASTM C 1047-94, Specification for Accessories for Gypsum Wallboard and Gypsum Veneer Base.
 - .12 ASTM C 1280-94, Specification for Application of Gypsum Sheathing Board.
- .3 Canadian General Standards Board (CGSB)
 - .1 CAN/CGSB-51.34-M86, Vapour Barrier, Polyethylene Sheet for Use in Building Construction.
 - .2 CAN/CGSB-71.25-M88, Adhesive, for Bonding Drywall to Wood Framing and Metal Studs.
- .4 Underwriters Laboratories of Canada (ULC)

- .1 CAN/ULC-S102-1988, Building Materials and Assemblies, Standard Method of Test for Surface Burning Characteristics of.

PART 2 PRODUCTS

.1 Materials

- .1 Standard board: to ASTM C 36 regular, 13mm thick, 16 mm thick and 16 mm Type X, 1200 mm wide x maximum practical length, ends square cut, edges bevelled.
- .2 Gypsum sheathing board: to ASTM C 79, regular, 16 mm thick and Type X, 16 mm thick , 1200 mm wide x maximum practical length,
- .3 Water-resistant board: to ASTM C 630 regular, 12mm thick and Type X, 12 mm thick, maximum practical length.
- .4 Nails: to ASTM C 514.
- .5 Steel drill screws: to ASTM C 1002.
- .6 Stud adhesive: to CAN/CGSB-71.25.
- .7 Laminating compound: as recommended by manufacturer, asbestos-free.
- .8 Sealants: in accordance with Section 07900.
- .9 Acoustic sealant: See Section 07900.
- .10 Polyethylene: to CAN/CGSB-51.34, Type 2.
- .11 Insulating strip: rubberized, moisture resistant, 3 mm thick closed cell neoprene strip, 12 mm wide, with self sticking permanent adhesive on one face, lengths as required.
- .12 Joint compound: to ASTM C 475, asbestos-free.

PART 3 EXECUTION

.1 Erection

- .1 Do application and finishing of gypsum board in accordance with ASTM C 840 except where specified otherwise.
- .2 Do application of gypsum sheathing in accordance with ASTM C 1280.
- .3 Erect hangers and runner channels for suspended gypsum board ceilings in accordance with ASTM C 840 except where specified otherwise.
- .4 Support light fixtures by providing additional ceiling suspension hangers within 150 mm of each corner and at maximum 600 mm around perimeter of fixture.
- .5 Install Work level to tolerance of 1:1200.

- .6 Frame with furring channels, perimeter of openings for access panels, light fixtures, diffusers and grilles.
- .7 Furr for gypsum board faced vertical bulkheads within and at termination of ceilings.
- .8 Furr above suspended ceilings for gypsum board fire and sound stops and to form plenum areas as indicated.
- .9 Install wall furring for gypsum board wall finishes in accordance with ASTM C 840, except where specified otherwise.
- .10 Furr openings and around built-in equipment, cabinets, access panels, on four sides. Extend furring into reveals. Check clearances with equipment suppliers.
- .11 Furr duct shafts, beams, columns, pipes and exposed services where indicated.
- .12 Erect drywall resilient furring transversely across studs, spaced maximum 600 mm O.C. and not more than 150 mm from ceiling/wall juncture. Secure to each support with 38 mm common nail or 25 mm drywall screw.
- .13 Install 150 mm continuous strip of 12.7 mm gypsum board along base of partitions where resilient furring installed.

.2 Application

- .1 Do not apply gypsum board until bucks, anchors, blocking, electrical and mechanical Work are approved.
- .2 Apply single or double layer gypsum board to wood or metal furring or framing using screw fasteners for first layer, screw fasteners for second layer. Maximum spacing of screws 300 mm O.C.
- .3 Apply single layer gypsum board to concrete or concrete block surfaces, where indicated, using laminating adhesive. Brace or fasten gypsum board until fastening adhesive has set. Gypsum board shall be mechanically fastened at top and bottom of each sheet.
- .4 Apply water-resistant gypsum board where wall tiles to be applied and adjacent to slop sinks and janitors closets. Apply water-resistant sealant to edges, ends, cut-outs which expose gypsum core and to fastener heads. Do not apply joint treatment on areas to receive tile finish.
- .5 Apply 12 mm diameter bead of acoustic sealant continuously around periphery of each face of partitioning to seal gypsum board/structure junction where partitions abut fixed building components. Seal full perimeter of cut-outs around electrical boxes, ducts, in partitions where perimeter sealed with acoustic sealant.
- .6 On ceilings: Apply base layer prior to base layer application on walls; apply face layers in same sequence. Offset joints between layers at least 300mm (1'-0"). Apply base layers at right angles to supports unless otherwise indicated.

.3 Installation

- .1 Erect accessories straight, plumb or level, rigid and at proper plane. Use full length pieces where practical. Make joints tight, accurately aligned and rigidly secured. Mitre and fit corners accurately, free from rough edges. Secure at 150 mm
- .2 Install casing beads around perimeter of suspended ceilings.
- .3 Install casing beads where gypsum board butts against surfaces having no trim concealing junction and where indicated.
- .4 Install insulating strips continuously at edges of gypsum board and casing beads abutting metal window and exterior door frames, to provide thermal break.
- .5 Provide continuous polyethylene dust barrier behind and across control joints.
- .6 Locate control joints where indicated on drawings and at a maximum 6m (30').
- .7 Install control joints straight and true.
- .8 Apply Fast-Mask trim to all visible surfaces of dissimilar materials: i.e. To timber, PVC, metal, masonry, glass, etc.
- .9 Install access doors to electrical and mechanical fixtures specified in respective Sections.
 - .1 Rigidly secure frames to furring or framing systems.
- .10 Finish face panel joints and internal angles with joint system consisting of joint compound, joint tape and taping compound installed according to manufacturer's directions and feathered out onto panel faces.
- .11 Finish corner beads, control joints and trim as required with two coats of joint compound and one coat of taping compound, feathered out onto panel faces.
- .12 Fill screw head depressions with joint and taping compounds to bring flush with adjacent surface of gypsum board so as to be invisible after surface finish is completed.
- .13 Sand lightly to remove burred edges and other imperfections. Avoid sanding adjacent surface of board.
- .14 Completed installation to be smooth, level or plumb, free from waves and other defects and ready for surface finish.
- .15 Remove ridges by light sanding or wiping with damp cloth.
- .16 Install sound attenuation blankets where indicated.
- .17 Install ceiling boards in the direction that will minimize the number of end-but joints. Stagger end joints at least 300mm (1'-0").

- .18 Install gypsum board on wall vertically to avoid end-butt joints. At stairwells and similar high walls, install boards horizontally with end joints staggered over studs, except where local codes or fire-rated assemblies require vertical application.
- .19 Install gypsum board with face side out. Do not install damaged or damp boards.
- .20 Locate edge or end joints over supports. Stagger vertical joints over different studs on opposite side of wall.

.4 Schedules

- .1 Construct fire rated assemblies where indicated.

END OF SECTION

Part 1 General

1.1 RELATED SECTIONS

- .1 Section 01330 – Submittal Procedures

1.2 WORK INCLUDED

- .1 The Work included under this section shall conform to the industry standard and be accepted by the local construction and trade associations.

1.3 QUALITY ASSURANCE

- .1 Conform to TTMAC requirements for Quarry Tile Manual and Maintenance Guide.

1.4 SUBMITTALS

- .1 Submit samples to requirements of Section 01330.
.2 Include cleaning methods, cleaning solutions recommended, stain removal methods, and polishes and waxes recommended.

Part 2 Products

2.1 MATERIALS

- .1 Porcelain Floor Tile (at Entry): to be 300x300 with 150 base. Color as selected by Contract Administrator from full range. Allow for one color. “Porcelain Stone”, Porcelain Tile, TEI IV, as supplied by Primco.
.2 Porcelain Wall (at all Washrooms): to be 300 x 300. Color as selected by Contract Administrator. Allow for two colors in each room. “Plaza” by Olympia Tile, or approved equal.

2.2 MORTAR MATERIALS

- .1 Mortar Materials: TTMAC requirements for Portland cement, sand, and water.

2.3 MORTAR BED

- .1 Mortar Bed: Latex - reinforced thinset mortar, as recommended by manufacturer.

2.4 GROUT TYPE

- .1 Grout: Sanded grout with acrylic additive.

2.5 TRIM

- .1 Purpose made tile trim by Schluter Systems (Canada) (800) 361.3127. Suit to tile thickness. Finish and colour to be determined by Contract Administrator: At floor /wall junctions: DILEX –EKE; at tile edge at junction with carpet: SCHEINE-M; at external corners: RONDEC, Contour edge transition CT-XX, or CCA-XX as required, color as selected by Contract Administrator as supplied by Primco (Sue 633-7256) or approved equal.

2.6 SURFACE PREPARATION MATERIALS

- .1 Spot patching and build up not more than 13mm: Ultra/Plan self- leveling cementitious underlayment compound.
- .2 Build up greater than 13mm: Planicrete 50 additive with sand/cement mortar.

Part 3 Execution

3.1 INSPECTION

- .1 Verify that surfaces are ready to receive Work.
- .2 Beginning of installation means acceptance of substrate.

3.2 INSTALLATION

- .1 Install quarry tile floor and base in accordance with TTMAC.
- .2 Lay tile to pattern indicated. Verify pattern is uninterrupted through openings.
- .3 Cut and fit tile tight to protrusions and vertical interruptions. Form corners and bases neatly.
- .4 Work tile joints uniform in width, subject to variance in tolerance allowed in tile size. Joints: Watertight, without voids, cracks, excess mortar, or grout.
- .5 Allow tile to set for a minimum of 48 hours prior to grouting.
- .6 Cut wall tile to 1/2 width at all curves.

3.3 CLEANING

- .1 Clean quarry tile surfaces in accordance with TTMAC Maintenance Guide.
- .2 Prohibit traffic from floor finish for 48 hours after installation.

END OF SECTION

PART 1 GENERAL

1.1 References

- .1 American Society for Testing and Materials (ASTM)
 - .1 ASTM F 1066- 95a, Specification for Vinyl Composition Floor tile.
 - .2 ASTM F 1344- 93, Specification for Rubber Tile.
- .2 Canadian General Standards Board (CGSB)
 - .1 CAN/CGSB-25.20- 95, Surface Sealer for Floors.
 - .2 CAN/CGSB-25.21- 95, Detergent-Resistant Floor Polish.

1.2 Related Sections

- .1 Section 00301 - Separate Prices.
- .2 Section 09911 – Interior Painting (Gym floor lines).

1.3 Closeout Submittals

- .1 Provide maintenance data for resilient flooring for incorporation into manual specified in Section 01780 - Closeout Submittals.

1.4 Waste Management and Disposal

- .1 Separate and recycle waste materials in accordance with Section 01355 - Waste Management and Disposal and the Waste Reduction Workplan, and the Waste Management plan to the maximum extent economically possible.
- .2 Donate flooring remnants to local civic organizations rather than disposing of them in landfills or incinerators. Set aside and protect offcuts and remainders greater than 300 x 300 for re-use, for example, Habitat for Humanity, or animal shelter.
- .3 Separate and recycle offcuts and waste materials in accordance with the Waste Management Plan and to the maximum extent economically feasible.
- .4 Place materials defined as hazardous or toxic waste in designated containers.
- .5 Return solvent and oil soaked rags, used during installation, for contaminant recovery, or laundering or for proper disposal.
- .6 Use trigger operated spray nozzles for water hoses.
- .7 Close and seal tightly all partly used sealant and adhesive containers and store protected in well ventilated fire-safe area at moderate temperature.

- .8 Place used sealant and adhesive tubes and containers in areas designated for hazardous waste.

1.5 Environmental Requirements

- .1 Maintain air temperature and structural base temperature at flooring installation area above 20°C for 48 hours before, during and for 48 hours after installation.

1.6 Extra Materials

- .1 Provide maintenance materials of resilient tile flooring, base and adhesive in accordance with Section 01780 - Closeout Submittals.
- .2 Provide 2 square metres of each color, pattern and type flooring material required for this project for maintenance use.
- .3 Extra materials to be from same production run as installed materials.
- .4 Clearly identify each container of floor tile and each container of adhesive.
- .5 Deliver to City, upon completion of the Work of this section.
- .6 Store where directed by Contract Administrator.

PART 2 PRODUCTS

2.1 Materials

- .1 Resilient flooring must:
 - .1 meet or exceed all applicable governmental and industrial safety and performance standards; and
 - .2 be manufactured and transported in such a manner that all steps of the process, including the disposal of waste products arising there from, will meet the requirements of all applicable governmental acts, by laws and regulations including, for facilities located in Canada, the Fisheries Act and the Canadian Environmental Protection Act (CEPA).
- .2 Sheet Vinyl flooring must:
 - .1 not be manufactured or formulated with cadmium, (Cd), chromium (Cr), lead (Pb), mercury (Hg), and nickel (Ni);
 - .2 not contain > 0.01 % by weight of arsenic (As);
 - .3 not contain > 1 % by weight of tin (Sn), or zinc (Zn);
 - .4 not be manufactured or formulated with short-chained chlorinated paraffin waxes (C. 13), or nonylphenol;
 - .5 not contain or be manufactured with materials derived from species listed on the Convention on International Trade in Endangered Species (CITES); and

- .6 Acceptable material: XL-Pu by Polyflor, Thickness 1.5mm. Color from complete range. Adhesive : H-92 by PolyFlor. Ensure adequate ventilation during installation and curing. As supplied by Primco (Sue 633-7256). Approved equal: Tarkett Granit, 2mm, from standard colors as supplied by ERV Parent (John 475-3555).
- .3 Resilient base: to vinyl, coved, minimum 1200 mm length and 108 mm high x 3 mm thick, including premoulded end stops and external corners for coved base only, of colour selected by Contract Administrator from full range of colors.
- .1 Acceptable material: Johnsonite "Recess" with toe base, or approved equal. As supplied by Primco (Sue 633-7256).
- .4 In the selection of resilient tile and related coatings, adhesives, solvents, cleaners, and other fluids, select those with the following characteristics: low Volatile Organic Compound (VOC) content, manufactured without compounds which contribute to ozone depletion in the upper atmosphere, does not contain chlorinated hydrocarbons.
- .5 Primers and adhesives: recommended by flooring manufacturer for specific material on applicable substrate, above, at or below grade.
- .6 Sub-floor filler and leveller: portland cement base underlayment and patching compound c/w additive as recommended by flooring manufacturer for use with their product.
- .7 Sealer: type recommended by flooring manufacturer.
- .8 Multi-Function Flooring / Washrooms: Johnsonite "Replay - Fusion" 3/8" thick, 24" x 24", square tiles, allow for 10% decorator solids, color as chosen by Contract Administrator from full color range.

Equal: Dinoflex "Sportmat" 3/8" thick, square tile, 30% color flex (Color as selected by Contract Administrator from standard color range), allow for 10% "Stone line" tiles.

Equal: Mondo Ramflex or Sport Impact, square tiles, 3/8" thick, color(s) as chosen by Contract Administrator from full color range.

Gym Floor; Mondo Advance, 6mm thick, one color from full range of colors with 10 year warranty.
- .9 Gym Floor (Separate Price, see Section 00301); Vinyl composition tile: to ASTM F 1066, Composition 1 - non asbestos Class 2 - through pattern tile, 3 mm, 305 x 305 mm size, colour selected by Contract Administrator. Acceptable material: Armstrong – Excelon, Mannington – Essentials and Designer Essentials, Amtico – micro edged only.

PART 3 EXECUTION

3.1 Inspection

- .1 Concrete Moisture Test: Perform moisture tests on concrete floors regardless of the age or grade level with a minimum of three tests for the first 1000 square feet. The test shall be a calcium chloride test. One test shall be conducted for every 1000 square feet of flooring. The test shall be conducted around the perimeter of the room, at columns and where moisture may be evident. The moisture emission from the concrete shall not exceed 3.0 lbs per 1000 square feet in 24 hours. For the most accurate results, the weight of the calcium chloride dish shall be made on the job site at the start and end of each test. A diagram of the area showing the location and results of each test shall be submitted to the Contract Administrator and Contractor. If the test results exceed the limitations, the installation shall not proceed until the problem has been corrected.
- .2 Concrete pH Test: Perform pH tests on concrete floors regardless of the age or grade level. If the pH is greater than 10, it must be neutralized prior to beginning the installation.

3.2 Meetings

- .1 Prior to and during flooring installation, flooring manufacturer representative and Contractor shall conduct on-site meetings for installation procedures and techniques for entire flooring installation.

3.3 Sub-floor Treatment

- .1 Remove sub-floor ridges and bumps. Fill low spots, cracks, joints, holes and other defects with sub-floor filler.
- .2 Clean floor and apply filler; trowel and float to leave smooth, flat hard surface. Prohibit traffic until filler cured and dry.

3.4 Tile Application

- .1 Provide a high ventilation rate, with maximum outside air, during installation, and for 48 to 72 hours after installation. If possible, vent directly to the outside. Do not let contaminated air re-circulate through a district or whole building air distribution system. Maintain extra ventilation for at least one month following building occupation.
- .2 To minimize emissions from adhesives, use water-based, solvent-free styrene-butadiene-rubber adhesive for linoleum. Butadiene exposure may cause eye and nose irritations, headaches, dizziness, and vomiting.
- .3 Apply adhesive uniformly using recommended trowel in accordance with flooring manufacturer's instructions. Do not spread more adhesive than can be covered by flooring before initial set takes place.

- .4 Lay flooring with joints parallel to building lines to produce symmetrical tile pattern. Border tiles minimum half tile width.
- .5 Install flooring to patterns as indicated.
- .6 As installation progresses, roll flooring in 2 directions including] resilient tile with 45 kg minimum roller to ensure full adhesion.
- .7 Cut tile and fit neatly around fixed objects.
- .8 Install feature strips and floor markings where indicated. Fit joints tightly.
- .9 Install flooring in pan type floor access covers. Maintain floor pattern.
- .10 Continue flooring through areas to receive movable type partitions without interrupting floor pattern.
- .11 Terminate flooring at centerline of door in openings where adjacent floor finish or colour is dissimilar.
- .12 Install metal edge strips at unprotected or exposed edges where flooring terminates.

3.5 Base Application

- .1 Lay out base to keep number of joints at minimum. Base joints at maximum length available or at internal or pre-moulded corners.
- .2 Clean substrate and prime with one coat of adhesive.
- .3 Apply adhesive to back of base.
- .4 Set base against wall and floor surfaces tightly by using 3 kg hand roller.
- .5 Install straight and level to variation of 1:1000.
- .6 Scribe and fit to door frames and other obstructions. Use pre-moulded end pieces at flush door frames.
- .7 Cope internal corners. Use pre-moulded corner units for right angle external corners. Use formed straight base material for external corners of other angles, minimum 300 mm each leg. Wrap around toeless base at external corners.

3.6 Initial Cleaning and Waxing

- .1 Remove excess adhesive from floor, base and wall surfaces without damage.

3.7 Protection of Finished Work

- .1 Protect new floors from time of final set of adhesive after initial waxing until final inspection.
- .2 Prohibit traffic on floor for 48 hours after installation.

END OF SECTION

PART 1 GENERAL

1.1 Related Sections

- .1 Section 01330 - Submittal Procedures.
- .2 Section 01355 - Waste Management and Disposal.
- .3 Section 01450 - Quality Control.
- .4 Section 01610 - Basic Product Requirements.
- .5 Section 01780 - Closeout Submittals.
- .6 Section 06201 - Finish Carpentry.
- .7 Section 06400 - Architectural Woodwork.
- .8 Section 09912 - Exterior Painting.

1.2 References

- .1 Architectural Painting Specifications Manual, Master Painters Institute (MPI).
- .2 Systems and Specifications Manual, SSPC Painting Manual, Volume Two, Society for Protective Coatings (SSPC).
- .3 Test Method for Measuring Total Volatile Organic Compound Content of Consumer Products, Method 24 (for Surface Coatings) of the Environmental Protection Agency (EPA).
- .4 National Fire Code of Canada.

1.3 Quality Assurance

- .1 Contractor shall have a minimum of five years proven satisfactory experience. When requested, provide a list of last three comparable jobs including, job name and location, specifying authority, and project manager.
- .2 Qualified journeymen who have a "Tradesman Qualification Certificate of Proficiency" shall be engaged in painting Work. Apprentices may be employed provided they Work under the direct supervision of a qualified journeyman in accordance with trade regulations.
- .3 Conform to latest MPI requirements for interior painting Work including preparation and priming.
- .4 Materials (primers, paints, coatings, varnishes, stains, lacquers, fillers, thinners, solvents, etc.) shall be in accordance with MPI Painting Specification Manual

"Approved Product" listing and shall be from a single manufacturer for each system used.

- .5 Other paint materials such as linseed oil, shellac, turpentine, etc. shall be the highest quality product of an approved manufacturer listed in MPI Painting Specification Manual and shall be compatible with other coating materials as required.
- .6 Retain purchase orders, invoices and other documents to prove conformance with noted MPI requirements when requested by Contract Administrator.
- .7 Standard of Acceptance:
 - .1 Walls: No defects visible from a distance of 1000 mm at 90 deg to surface.
 - .2 Ceilings: No defects visible from floor at 45 deg to surface when viewed using final lighting source.
 - .3 Final coat to exhibit uniformity of colour and uniformity of sheen across full surface area.

1.4 Environmental Performance Requirements

- .1 Provide paint products meeting MPI "Environmentally Friendly", E2 ratings based on VOC (EPA Method 24) content levels.

1.5 Scheduling of Work

- .1 Submit Work schedule for various stages of painting to Contract Administrator for approval. Submit schedule minimum of 48 hours in advance of proposed operations.
- .2 Obtain written authorization from Contract Administrator for any changes in Work schedule.
- .3 Schedule painting operations to prevent disruption of occupants in and about the building.

1.6 Submittals

- .1 Submit product data and manufacturer's installation/application instructions for each paint and coating product to be used in accordance with Section 01330 - Submittal Procedures.
- .2 Submit WHMIS MSDS.- Material Safety Data Sheets.
- .3 Upon completion, submit records of products used. List products in relation to finish system and include the following:
 - .1 Product name, type and use.

- .2 Manufacturer's product number.
- .3 Colour numbers.
- .4 MPI Environmentally Friendly classification system rating.
- .5 Manufacturer's Material Safety Data Sheets (MSDS).

1.7 Samples

- .1 Submit full range colour sample chips in accordance with Section 01330 - Submittal Procedures. Indicate where colour availability is restricted.
- .2 Submit 200 x 300 mm sample panels of each paint, stain and special finish with specified paint or coating in colours, gloss/sheen and textures required to MPI Painting Specification Manual standards submitted on the following substrate materials:
 - .1 3 mm plate steel for finishes over metal surfaces.
 - .2 13 mm birch plywood for finishes over wood surfaces.
 - .3 50 mm concrete block for finishes over concrete or concrete masonry surfaces.
 - .4 13 mm gypsum board for finishes over gypsum board and other smooth surfaces.
 - .5 10 mm plywood for finishes over wood surfaces.
- .3 When approved, sample panels shall become acceptable standard of quality for appropriate on-site surface with one of each sample retained on-site.

1.8 Quality Control

- .1 When requested by Contract Administrator, prepare and paint designated surface, area, room or item (in each colour scheme) to requirements specified herein, with specified paint or coating showing selected colours, gloss/sheen, textures and workmanship to MPI Painting Specification Manual standards for review and approval. When approved, surface, area, room and/or items shall become acceptable standard of finish quality and workmanship for similar on-site Work.

1.9 Extra Materials

- .1 Submit maintenance materials in accordance with Section 01780 - Closeout Submittals.
- .2 Submit one - four litre can of each type and colour of stain and finish coating. Identify colour and paint type in relation to established colour schedule and finish system.
- .3 Deliver to Contractor and store where directed.

1.10 Delivery, Handling and Storage

- .1 Deliver, store and handle materials in accordance with Section 01610 - Basic Product Requirements.
- .2 Labels shall clearly indicate:
 - .1 Manufacturer's name and address.
 - .2 Type of paint or coating.
 - .3 Compliance with applicable standard.
 - .4 Colour number in accordance with established colour schedule.
- .3 Remove damaged, opened and rejected materials from site.
- .4 Provide and maintain dry, temperature controlled, secure storage.
- .5 Observe manufacturer's recommendations for storage and handling.
- .6 Store materials and supplies away from heat generating devices.
- .7 Store materials and equipment in a well ventilated area with temperature range 7 deg C to 30 deg C.
- .8 Store temperature sensitive products above minimum temperature as recommended by manufacturer.
- .9 Keep areas used for storage, cleaning and preparation, clean and orderly to approval of Contract Administrator. After completion of operations, return areas to clean condition to approval of Contract Administrator.
- .10 Remove paint materials from storage only in quantities required for same day use.
- .11 Comply with requirements of Workplace Hazardous Materials Information System (WHMIS) regarding use, handling storage, and disposal of hazardous materials.
- .12 Fire Safety Requirements:
 - .1 Provide one 9 kg Type ABC fire extinguisher adjacent to storage area.
 - .2 Store oily rags, waste products, empty containers and materials subject to spontaneous combustion in ULC approved, sealed containers and remove from site on a daily basis.
 - .3 Handle, store, use and dispose of flammable and combustible materials in accordance with the National Fire Code of Canada.

1.11 Site Requirements

- .1 Heating, Ventilation and Lighting:

- .1 Ventilate enclosed spaces.
 - .2 Perform no painting Work unless adequate and continuous ventilation and sufficient heating facilities are in place to maintain ambient air and substrate temperatures above 10 deg C for 24 hours before, during and after paint application until paint has cured sufficiently.
 - .3 Where required, provide continuous ventilation for seven days after completion of application of paint.
 - .4 Provide temporary ventilating and heating equipment where permanent facilities are not available or supplemental ventilating and heating equipment if ventilation and heating from existing system is inadequate to meet minimum requirements.
 - .5 Perform no painting Work unless a minimum lighting level of 323 Lux is provided on surfaces to be painted. Adequate lighting facilities shall be provided by Contractor.
- .2 Temperature, Humidity and Substrate Moisture Content Levels:
- .1 Unless specifically pre-approved by the specifying body and the applied product manufacturer, perform no painting Work when:
 - .1 Ambient air and substrate temperatures are below 10 deg C.
 - .2 Substrate temperature is over 32 deg C unless paint is specifically formulated for application at high temperatures.
 - .3 Substrate and ambient air temperatures are expected to fall outside MPI or paint manufacturer's prescribed limits.
 - .4 The relative humidity is above 85% or when the dew point is less than 3 deg C variance between the air/surface temperature.
 - .2 Perform no painting Work when the maximum moisture content of the substrate exceeds:
 - .1 12% for concrete and masonry (clay and concrete brick/block).
 - .2 15% for wood.
 - .3 12% for plaster and gypsum board.
 - .3 Conduct moisture tests using a properly calibrated electronic Moisture Meter, except test concrete floors for moisture using a simple "cover patch test".
 - .4 Test concrete, masonry and plaster surfaces for alkalinity as required.
- .3 Surface and Environmental Conditions:
- .1 Apply paint finish only in areas where dust is no longer being generated by related construction operations or when wind or ventilation conditions are such that airborne particles will not affect quality of finished surface.
 - .2 Apply paint only to adequately prepared surfaces and to surfaces within moisture limits noted herein.

- .3 Apply paint only when previous coat of paint is dry or adequately cured.
- .4 Additional Interior Application Requirements:
 - .1 Apply paint finishes only when temperature at location of installation can be satisfactorily maintained within manufacturer's recommendations.

1.12 Waste Management and Disposal

- .1 Separate and recycle waste materials in accordance with Section 01355 - Waste Management and Disposal.
- .2 Paint, stain and wood preservative finishes and related materials (thinners, solvents, etc.,) are regarded as hazardous products and are subject to regulations for disposal. Information on these controls can be obtained from Provincial Ministries of Environment and Regional levels of Government.
- .3 Material which cannot be reused must be treated as hazardous waste and disposed of in an appropriate manner.
- .4 Place materials defined as hazardous or toxic waste, including used sealant and adhesive tubes and containers, in containers or areas designated for hazardous waste.
- .5 To reduce the amount of contaminants entering waterways, sanitary/storm drain systems or into ground the following procedures shall be strictly adhered to:
 - .1 Retain cleaning water for water-based materials to allow sediments to be filtered out.
 - .2 Retain cleaners, thinners, solvents and excess paint and place in designated containers and ensure proper disposal.
 - .3 Return solvent and oil soaked rags used during painting operations for contaminant recovery, proper disposal, or appropriate cleaning and laundering.
 - .4 Dispose of contaminants in an approved legal manner in accordance with hazardous waste regulations.
 - .5 Empty paint cans are to be dry prior to disposal or recycling (where available).
- .6 Where paint recycling is available, collect waste paint by type and provide for delivery to recycling or collection facility.
- .7 Close and seal tightly partly used sealant and adhesive containers and store protected in well ventilated fire-safe area at moderate temperature.

PART 2 PRODUCTS

2.1 Materials

- .1 Only paint materials listed in the MPI Approved Products List (APL) are acceptable for use on this project.
- .2 Paint materials for paint systems shall be products of a single manufacturer.
- .3 Only qualified products with E2 "Environmentally Friendly" rating are acceptable for use on this project.
- .4 Paints, coatings, adhesives, solvents, cleaners, lubricants, and other fluids, shall:
 - .1 be water-based unless otherwise specified.
 - .2 be manufactured without compounds which contribute to ozone depletion in the upper atmosphere.
 - .3 do not contain toxic metal pigments.
 - .4 have a recycled content if cost neutral.
- .5 Water-borne surface coatings must be manufactured and transported in a manner that steps of process, including disposal of waste products arising therefrom, will meet requirements of applicable governmental acts, by-laws and regulations including, for facilities located in Canada, Fisheries Act and Canadian Environmental Protection Act (CEPA).
- .6 Water-borne surface coatings must not be formulated or manufactured with aromatic solvents, formaldehyde, halogenated solvents, mercury, lead, cadmium, hexavalent chromium or their compounds.
- .7 Water-borne surface coatings and recycled water-borne surface coatings must have a flash point of 61.0 deg C or greater.
- .8 Both water-borne surface coatings and recycled water-borne surface coatings must be made by a process that does not release:
 - .1 Matter in undiluted production plant effluent generating a 'Biochemical Oxygen Demand' (BOD) in excess of 15 mg/L to a natural watercourse or a sewage treatment facility lacking secondary treatment.
 - .2 Total Suspended Solids (TSS) in undiluted production plant effluent in excess of 15 mg/L to a natural watercourse or a sewage treatment facility lacking secondary treatment.
- .9 Water-borne paints and stains, recycled water-borne surface coatings and water borne varnishes must meet a minimum "Environmentally Friendly" E2 rating.
- .10 Recycled water-borne surface coatings must not contain:
 - .1 Lead in excess of 600.0 ppm weight/weight total solids.
 - .2 Mercury in excess of 50.0 ppm weight/weight total product.
 - .3 Cadmium in excess of 1.0 ppm weight/weight total product.
 - .4 Hexavalent chromium in excess of 3.0 ppm weight/weight total product.

- .5 Organochlorines or polychlorinated biphenyls (PCBS) in excess of 1.0 ppm weight/weight total product.
- .11 The following must be performed on each batch of consolidated post-consumer material before surface coating is reformulated and canned. These tests must be performed at a laboratory or facility which has been accredited by the Standards Council of Canada.
 - .1 Lead, cadmium and chromium are to be determined using ICP-AES (Inductively Coupled Plasma - Atomic Emission Spectroscopy) technique no. 6010 as defined in EPA SW-846.
 - .2 Mercury is to be determined by Cold Vapour Atomic Absorption Spectroscopy using Technique no. 7471 as defined in EPA SW-846.
 - .3 Organochlorines and PCBs are to be determined by Gas Chromatography using Technique no. 8081 as defined in EPA SW-846.

2.2 Colours

- .1 Contract Administrator will provide Colour Schedule after Contract award.
- .2 Colour schedule will be based upon the selection of four base colours and two accent colours. No more than eight colours will be selected for the entire project and no more than five colours will be selected in each area.
- .3 Selection of colours will be from manufacturers full range of colours.
- .4 Where specific products are available in a restricted range of colours, selection will be based on the limited range.
- .5 Second coat in a three coat system to be tinted slightly lighter colour than top coat to show visible difference between coats.

2.3 Mixing and Tinting

- .1 Perform colour tinting operations prior to delivery of paint to site. On-site tinting of painting materials is allowed only with Contract Administrator's written permission.
- .2 Paste, powder or catalyzed paint mixes shall be mixed in strict accordance with manufacturer's written instructions.
- .3 Where thinner is used, addition shall not exceed paint manufacturer's recommendations. Do not use kerosene or any such organic solvents to thin water-based paints.
- .4 Thin paint for spraying according in strict accordance with paint manufacturer's instructions. If directions are not on container, obtain instructions in writing from manufacturer and provide copy of instructions to Contract Administrator.

- .5 Re-mix paint in containers prior to and during application to ensure break-up of lumps, complete dispersion of settled pigment, and colour and gloss uniformity.

2.4 Gloss/Sheen Ratings

- .1 Paint gloss shall be defined as the sheen rating of applied paint, in accordance with the following values:

| Gloss Level Category | Units @ 60 deg | Units @ 85 deg |
|------------------------|----------------|----------------|
| G1 - matte finish | 0 to 5 | max. 10 |
| G2 - velvet finish | 0 to 10 | 10 to 35 |
| G3 - eggshell finish | 10 to 25 | 10 to 35 |
| G4 - satin finish | 20 to 35 | min. 35 |
| G5 - semi-gloss finish | 35 to 70 | |
| G6 - gloss finish | 70 to 85 | |
| G7 - high gloss finish | > 85 | |

- .2 Gloss level ratings of painted surfaces shall be as specified herein.

2.5 Interior Painting Systems

- .1 Galvanized Metal: doors, frames, railings, misc. steel, pipes, overhead decking, etc.
 - .1 INT 5.3J Latex MPI Gloss level 3 finish over waterborne primer.
- .2 Aluminum: unanodized
 - .1 INT 5.4D Aluminum paint finish (for exposed aluminum).
- .3 Stainless Steel: unpolished
 - .1 INT 5.6H Latex MPI Gloss level 2 finish.
- .4 Dimension Lumber: where occurs exposed.
 - .1 INT 6.2K Alkyd varnish to meet MPI #74 classification.
- .5 Dressed Lumber and strawboard panels: including casings, mouldings, wall panelling, etc.
 - .1 Stain color "A"
 - .1 INT 6.3C Semi-transparent stain finish to MPI 90.
 - .2 INT 6.3F Interior oil modified Urethane, clear, satin, to MPI classification 57, E-range 2 or 3.
 - .2 Stain color "B"
 - .1 INT 6.3C Semi-transparent stain finish to MPI 90.
 - .2 INT 6.3F Interior oil modified Urethane, clear, satin, to MPI classification 57, E-range 2 or 3.

- .3 Stain color "C"
 - .1 INT 6.3C Semi-transparent stain finish to MPI 90.
 - .2 INT 6.3F Interior oil modified Urethane, clear, satin, to MPI classification 57, E-range 2 or 3.
- .6 Gypsum Board: gypsum wallboard, drywall, "sheet rock type material", etc., and textured finishes vertical.
 - .1 INT 9.2A Latex MPI Gloss level 3 finish over latex sealer (typical).
 - .2 INT 9.2A Latex MPI Gloss level 5 finish over latex sealer (kitchens, washrooms).
- .7 Plaster and Gypsum Board: gypsum wallboard, drywall, "sheet rock type material", etc., and textured finishes horizontal.
 - .1 INT 9.2A Latex MPI Gloss level 3 finish over latex sealer (typical).
 - .2 INT 9.2A Latex MPI Gloss level 5 finish over latex sealer (kitchens, washrooms).
- .8 Game Lines in gymnasium:
 - .1 INT Alkyd to MPI #48, Gloss.

PART 3 EXECUTION

3.1 General

- .1 Perform preparation and operations for interior painting in accordance with MPI Painting Specifications Manual except where specified otherwise.
- .2 Apply paint materials in accordance with paint manufacturer's written application instructions.

3.2 Existing Conditions

- .1 Investigate existing substrates for problems related to proper and complete preparation of surfaces to be painted. Report to Contract Administrator damages, defects, unsatisfactory or unfavourable conditions before proceeding with Work.
- .2 Conduct moisture testing of surfaces to be painted using a properly calibrated electronic moisture meter, except test concrete floors for moisture using a simple "cover patch test" and report findings to Contract Administrator. Do not proceed with Work until conditions fall within acceptable range as recommended by manufacturer.
- .3 Maximum moisture content as follows:
 - .1 Stucco, Plaster and Gypsum Board: 12%.

- .2 Concrete: 12%.
- .3 Clay and Concrete Block/Brick: 12%.
- .4 Wood: 15%.

3.3 Protection

- .1 Protect existing building surfaces and adjacent structures from paint spatters, markings and other damage by suitable non-staining covers or masking. If damaged, clean and restore such surfaces as directed by Contract Administrator.
- .2 Protect items that are permanently attached such as Fire Labels on doors and frames.
- .3 Protect factory finished products and equipment.
- .4 Protect passing pedestrians and general public about the building.
- .5 Removal of electrical cover plates, light fixtures, surface hardware on doors, bath accessories and other surface mounted equipment, fittings and fastenings shall be done prior to undertaking any painting operations by Contractor. Items shall be securely stored and re-installed after painting is completed by Contractor.
- .6 Move and cover furniture and portable equipment as necessary to carry out painting operations. Replace as painting operations progress.

3.4 Cleaning and Preparation

- .1 Clean and prepare surfaces in accordance with MPI Painting Specification Manual requirements. Refer to MPI Manual in regard to specific requirements and as follows:
 - .1 Remove dust, dirt, and other surface debris by vacuuming or wiping with dry, clean cloths.
 - .2 Wash surfaces with a biodegradable detergent and bleach where applicable] and clean warm water using a stiff bristle brush to remove dirt, oil and other surface contaminants.
 - .3 Rinse scrubbed surfaces with clean water until foreign matter is flushed from surface.
 - .4 Allow surfaces to drain completely and allow to dry thoroughly.
 - .5 Prepare surfaces for water-based painting, water-based cleaners should be used in place of organic solvents.
 - .6 Use trigger operated spray nozzles for water hoses.
 - .7 Many water-based paints cannot be removed with water once dried. However, minimize the use of kerosene or any such organic solvents to clean up water-based paints.

- .2 Prevent contamination of cleaned surfaces by salts, acids, alkalis, other corrosive chemicals, grease, oil and solvents before prime coat is applied and between applications of remaining coats. Apply primer, paint, or pretreatment as soon as possible after cleaning and before deterioration occurs.
- .3 Where possible, prime surfaces of new wood surfaces before installation. Use same primers as specified for exposed surfaces.
 - .1 Apply vinyl sealer to MPI #36 over knots, pitch, sap and resinous areas.
 - .2 Apply wood filler to nail holes and cracks.
 - .3 Tint filler to match stains for stained woodwork.
- .4 Sand and dust between coats as required to provide adequate adhesion for next coat and to remove defects visible from a distance up to 1000 mm.
- .5 Clean metal surfaces to be painted by removing rust, loose mill scale, welding slag, dirt, oil, grease and other foreign substances in accordance with MPI requirements. Remove traces of blast products from surfaces, pockets and corners to be painted by blowing with clean dry compressed air, or vacuum cleaning.
- .6 Touch up of shop primers with primer as specified in applicable section. Major touch-up including cleaning and painting of field connections, welds, rivets, nuts, washers, bolts, and damaged or defective paint and rusted areas, shall be by supplier of fabricated material.
- .7 Do not apply paint until prepared surfaces have been accepted by Contract Administrator.

3.5 Application

- .1 Method of application to be as approved by Contract Administrator. Apply paint by brush and roller. Conform to manufacturer's application instructions unless specified otherwise.
- .2 Brush and Roller Application:
 - .1 Apply paint in a uniform layer using brush and/or roller of types suitable for application.
 - .2 Work paint into cracks, crevices and corners.
 - .3 Paint surfaces and corners not accessible to brush using spray, daubers and/or sheepskins. Paint surfaces and corners not accessible to roller using brush, daubers or sheepskins.
 - .4 Brush and/or roll out runs and sags, and over-lap marks. Rolled surfaces shall be free of roller tracking and heavy stipple unless approved by Contract Administrator.
 - .5 Remove runs, sags and brush marks from finished Work and repaint.

- .3 Use dipping, sheepskins or daubers only when no other method is practical in places of difficult access and only when specifically authorized by Contract Administrator.
- .4 Apply coats of paint as a continuous film of uniform thickness. Repaint thin spots or bare areas before next coat of paint is applied.
- .5 Allow surfaces to dry and properly cure after cleaning and between subsequent coats for minimum time period as recommended by manufacturer.
- .6 Sand and dust between coats to remove visible defects.
- .7 Finish surfaces both above and below sight lines as specified for surrounding surfaces, including such surfaces as tops of interior cupboards and cabinets and projecting ledges.
- .8 Finish closets and alcoves as specified for adjoining rooms.
- .9 Finish top, bottom, edges and cutouts of doors after fitting as specified for door surfaces.

3.6 Mechanical/Electrical Equipment

- .1 Unless otherwise specified, paint finished area exposed conduits, piping, hangers, ductwork and other mechanical and electrical equipment with colour and finish to match adjacent surfaces, except as noted otherwise.
- .2 Janitor room, mechanical and electrical rooms: no painting required on exposed conduits, piping, hangers, ductwork and other mechanical and electrical equipment.
- .3 Other unfinished areas: leave exposed conduits, piping, hangers, ductwork and other mechanical and electrical equipment in original finish and touch up scratches and marks.
- .4 Touch up scratches and marks on factory painted finishes and equipment with paint as supplied by manufacturer of equipment.
- .5 Do not paint over nameplates.
- .6 Paint inside of ductwork where visible behind grilles, registers and diffusers with primer and one coat of matt black paint.
- .7 Paint disconnect switches for fire alarm system and exit light systems in red enamel.
- .8 Paint both sides and edges of backboards for telephone and electrical equipment before installation. Leave equipment in original finish except for touch-up as required, and paint conduits, mounting accessories and other unfinished items.

- .9 Do not paint interior transformers and substation equipment.

3.7 Field Quality Control

- .1 Field inspection of painting operations to be carried out by independent inspection firm as designated by Contract Administrator.
- .2 Advise Contract Administrator when surfaces and applied coating is ready for inspection. Do not proceed with subsequent coats until previous coat has been approved.
- .3 Co-operate with inspection firm and provide access to areas of Work.

3.8 Restoration

- .1 Clean and re-install all hardware items removed before undertaken painting operations.
- .2 Remove protective coverings and warning signs as soon as practical after operations cease.
- .3 Remove paint splashings on exposed surfaces that were not painted. Remove smears and spatter immediately as operations progress, using compatible solvent.
- .4 Protect freshly completed surfaces from paint droppings and dust to approval of Contract Administrator. Avoid scuffing newly applied paint.
- .5 Restore areas used for storage, cleaning, mixing and handling of paint to clean condition as approved by Contract Administrator.

END OF SECTION

PART 1 GENERAL

1.1 Related Sections

- .1 Section 01330 - Submittal Procedures.
- .2 Section 01355 - Waste Management and Disposal.
- .3 Section 01450 - Quality Control.
- .4 Section 01610 - Basic Product Requirements.
- .5 Section 01780 - Closeout Submittals.
- .6 Section 09911 – Interior Painting

1.2 References

- .1 Architectural Painting Specifications Manual, Master Painters Institute (MPI).
- .2 Systems and Specifications Manual, SSPC Painting Manual, Volume Two, Society for Protective Coatings (SSPC).
- .3 National Fire Code of Canada.

1.3 Quality Assurance

- .1 Contractor shall have a minimum of five years proven satisfactory experience. When requested, provide a list of last three comparable jobs including, job name and location, specifying authority, and project manager.
- .2 Qualified journeymen who have a "Tradesman Qualification Certificate of Proficiency" shall be engaged in painting Work. Apprentices may be employed provided they Work under the direct supervision of a qualified journeyman in accordance with trade regulations.
- .3 Conform to latest MPI requirements for exterior painting Work including preparation and priming.
- .4 Materials (primers, paints, coatings, varnishes, stains, lacquers, fillers, thinners, solvents, etc.) shall be in accordance with MPI Painting Specification Manual "Approved Product" listing and shall be from a single manufacturer for each system used.
- .5 Other paint materials such as linseed oil, shellac, turpentine, etc. shall be the highest quality product of an approved manufacturer listed in MPI Painting Specification Manual and shall be compatible with other coating materials as required.
- .6 Retain purchase orders, invoices and other documents to prove conformance with noted MPI requirements when requested by Contract Administrator.
- .7 Standard of Acceptance:

- .1 Walls: No defects visible from a distance of 1000 mm at 90 deg to surface.
- .2 Soffit: No defects visible from floor at 45 deg to surface when viewed using final lighting source.
- .3 Final coat to exhibit uniformity of colour and uniformity of sheen across full surface area.

1.4 Scheduling of Work

- .1 Submit Work schedule for various stages of painting to Contract Administrator for approval. Submit schedule minimum of 48 hours in advance of proposed operations.
- .2 Obtain written authorization from Contract Administrator for changes in Work schedule.
- .3 Schedule painting operations to prevent disruption of building occupants.

1.5 Submittals

- .1 Submit product data and manufacturer's installation/application instructions for paints and coating products to be used in accordance with Section 01330 - Submittal Procedures.
- .2 Upon completion, submit records of products used. List products in relation to finish system and include the following:
 - .1 Product name, type and use.
 - .2 Manufacturer's product number.
 - .3 Colour numbers.
 - .4 Manufacturer's Material Safety Data Sheets (MSDS).

1.6 Samples

- .1 Submit samples in accordance with Section 01330 - Submittal Procedures.
- .2 Submit 200 x 300 mm sample panels of each paint and stain with specified paint or coating in colours, gloss/sheen and textures required to MPI Painting Specification Manual standards submitted on the following substrate materials:
 - .1 3 mm plate steel for finishes over metal surfaces.
 - .2 13 mm birch plywood for finishes over wood surfaces.
 - .3 50 mm concrete block for finishes over concrete or concrete masonry surfaces.
 - .4 13 mm gypsum board for finishes over gypsum board and other smooth surfaces.
 - .5 10 mm plywood for finishes over wood surfaces.

- .3 When approved, samples shall become acceptable standard of quality for appropriate on-site surface with one of each sample retained on-site.
- .4 Submit full range of available colours where colour availability is restricted.

1.7 Quality Control

- .1 Provide mock-up in accordance with Section 01450 - Quality Control.
- .2 When requested by the Contract Administrator or Paint Inspection Agency, prepare and paint designated surface, area, room or item (in each colour scheme) to requirements specified herein, with specified paint or coating showing selected colours, gloss/sheen, textures and workmanship to MPI Painting Specification Manual standards for review and approval. When approved, surface, area, room and/or items shall become acceptable standard of finish quality and workmanship for similar on-site Work.

1.8 Extra Materials

- .1 Submit maintenance materials in accordance with Section 01780 - Closeout Submittals.
- .2 Submit one - four litre can of each type and colour of paint and stain. Identify colour and paint type in relation to established colour schedule and finish system.
- .3 Deliver to Contractor and store where directed.

1.9 Delivery, Handling and Storage

- .1 Deliver, store and handle materials in accordance with Section 01610 - Basic Product Requirements.
- .2 Deliver and store materials in original containers, sealed, with labels intact.
- .3 Labels shall clearly indicate:
 - .1 Manufacturer's name and address.
 - .2 Type of paint or coating.
 - .3 Compliance with applicable standard.
 - .4 Colour number in accordance with established colour schedule.
- .4 Remove damaged, opened and rejected materials from site.
- .5 Provide and maintain dry, temperature controlled, secure storage.
- .6 Observe manufacturer's recommendations for storage and handling.
- .7 Store materials and supplies away from heat generating devices.
- .8 Store materials and equipment in a well ventilated area with temperature range 7 deg C to 30 deg C.

- .9 Store temperature sensitive products above minimum temperature as recommended by manufacturer.
- .10 Keep areas used for storage, cleaning and preparation, clean and orderly to approval of Contract Administrator. After completion of operations, return areas to clean condition to approval of Contract Administrator.
- .11 Remove paint materials from storage only in quantities required for same day use.
- .12 Comply with requirements of Workplace Hazardous Materials Information System (WHMIS) regarding use, handling storage, and disposal of hazardous materials.
- .13 Fire Safety Requirements:
 - .1 Provide one 9 kg Type ABC fire extinguisher adjacent to storage area.
 - .2 Store oily rags, waste products, empty containers and materials subject to spontaneous combustion in ULC approved, sealed containers and remove from site on a daily basis.
 - .3 Handle, store, use and dispose of flammable and combustible materials in accordance with the National Fire Code of Canada.

1.10 Site Requirements

- .1 Heating, Ventilation and Lighting:
 - .1 Ventilate enclosed spaces.
 - .2 Perform no painting Work unless adequate and continuous ventilation and sufficient heating facilities are in place to maintain ambient air and substrate temperatures above 10 deg C for 24 hours before, during and after paint application until paint has cured sufficiently.
 - .3 Provide temporary ventilating and heating equipment where permanent facilities are not available or supplemental ventilating and heating equipment if ventilation and heating from existing system is inadequate to meet minimum requirements.
 - .4 Perform no painting Work unless a minimum lighting level of 323 Lux is provided on surfaces to be painted. Adequate lighting facilities shall be provided by Contractor.
- .2 Temperature, Humidity and Substrate Moisture Content Levels:
 - .1 Unless specifically pre-approved by specifying body, Paint Inspection Agency and, applied product manufacturer, perform no painting Work when:
 - .1 ambient air and substrate temperatures are below 10 deg C.
 - .2 substrate temperature is over 32 deg C unless paint is specifically formulated for application at high temperatures.
 - .3 substrate and ambient air temperatures are expected to fall outside MPI or paint manufacturer's prescribed limits.

- .4 the relative humidity is above 85% or when dew point is less than 3 deg C variance between air/surface temperature.
- .5 rain or snow are forecast to occur before paint has thoroughly cured or when it is foggy, misty, raining or snowing at site.
- .2 Perform no painting Work when maximum moisture content of substrate exceeds:
 - .1 12% for concrete and masonry (clay and concrete brick/block).
 - .2 15% for wood.
 - .3 12% for plaster and gypsum board.
- .3 Conduct moisture tests using a properly calibrated electronic Moisture Meter, except test concrete floors for moisture using a simple "cover patch test".
- .4 Test concrete, masonry and plaster surfaces for alkalinity as required.
- .3 Surface and Environmental Conditions:
 - .1 Apply paint finish only in areas where dust is no longer being generated by related construction operations or when wind or ventilation conditions are such that airborne particles will not affect quality of finished surface.
 - .2 Apply paint only to adequately prepared surfaces and to surfaces within moisture limits noted herein.
 - .3 Apply paint only when previous coat of paint is dry or adequately cured.
 - .4 Apply paint finishes only when conditions forecast for entire period of application fall within manufacturer's recommendations.
 - .5 Do not apply paint when:
 - .1 Temperature is expected to drop below 10 deg C before paint has thoroughly cured.
 - .2 Substrate and ambient air temperatures are expected to fall outside MPI or paint manufacturer's limits.
 - .3 Surface to be painted is wet, damp or frosted.
 - .6 Provide and maintain cover when paint must be applied in damp or cold weather. Heat substrates and surrounding air to comply with temperature and humidity conditions specified by manufacturer. Protect until paint is dry or until weather conditions are suitable.
 - .7 Schedule painting operations such that surfaces exposed to direct, intense sunlight are scheduled for completion during early morning.
 - .8 Remove paint from areas which have been exposed to freezing, excess humidity, rain, snow or condensation. Prepare surface again and repaint.

1.11 Waste Management and Disposal

- .1 Separate and recycle waste materials in accordance with Section 01355 - Waste Management and Disposal.

- .2 Paint, stain and wood preservative finishes and related materials (thinners, solvents, etc.) are regarded as hazardous products and are subject to regulations for disposal. Information on these controls can be obtained from Provincial Ministries of Environment and Regional levels of Government.
- .3 Material which cannot be reused must be treated as hazardous waste and disposed of in an appropriate manner.
- .4 Place materials defined as hazardous or toxic waste, including used sealant and adhesive tubes and containers, in containers or areas designated for hazardous waste.
- .5 To reduce the amount of contaminants entering waterways, sanitary/storm drain systems or into the ground the following procedures shall be strictly adhered to:
 - .1 Retain cleaning water for water-based materials to allow sediments to be filtered out.
 - .2 Retain cleaners, thinners, solvents and excess paint and place in designated containers and ensure proper disposal.
 - .3 Return solvent and oil soaked rags used during painting operations for contaminant recovery, proper disposal, or appropriate cleaning and laundering.
 - .4 Dispose of contaminants in an approved legal manner in accordance with hazardous waste regulations.
 - .5 Empty paint cans are to be dry prior to disposal or recycling (where available).
- .6 Where paint recycling is available, collect waste paint by type and provide for delivery to recycling or collection facility.
- .7 Close and seal tightly partly used sealant and adhesive containers and store protected in well ventilated fire-safe area at moderate temperature.

PART 2 PRODUCTS

2.1 Materials

- .1 Paint materials listed in the latest edition of the MPI Approved Products List (APL) are acceptable for use on this project.
- .2 Paint materials for paint systems shall be products of a single manufacturer.
- .3 Paints, coatings, adhesives, solvents, cleaners, lubricants, and other fluids, shall:
 - .1 be manufactured without compounds which contribute to ozone depletion in the upper atmosphere.
 - .2 do not contain toxic metal pigments.
- .4 Water-borne surface coatings must be manufactured and transported in a manner that steps of processes, including disposal of waste products arising therefrom, will meet requirements of applicable governmental acts, by-laws and

regulations including, for facilities located in Canada, Fisheries Act and Canadian Environmental Protection Act (CEPA).

- .5 Water-borne surface coatings must not be formulated or manufactured with formaldehyde, halogenated solvents, mercury, lead, cadmium, hexavalent chromium or their compounds.
- .6 Water-borne surface coatings and recycled water-borne surface coatings must have a flash point of 61.0 deg C or greater.

2.2 Colours

- .1 Contract Administrator will provide Colour Schedule after Contract award.
- .2 Colour schedule will be based upon selection of four base colours. No more than four colours will be selected for the entire project.
- .3 Selection of colours will be from manufacturers full range of colours.
- .4 Where specific products are available in a restricted range of colours, selection will be based on the limited range.
- .5 Second coat in a three coat system to be tinted slightly lighter colour than top coat to show visible difference between coats.

2.3 Mixing and Tinting

- .1 Perform colour tinting operations prior to delivery of paint to site. On-site tinting of painting materials is allowed only with Contract Administrator's written permission.
- .2 Paste, powder or catalyzed paint mixes shall be mixed in strict accordance with manufacturer's written instructions.
- .3 Where thinner is used, addition shall not exceed paint manufacturer's recommendations. Do not use kerosene or any such organic solvents to thin water-based paints.
- .4 Thin paint for spraying according in strict accordance with paint manufacturer's instructions. If directions are not on container, obtain instructions in writing from manufacturer and provide copy of instructions to Contract Administrator.
- .5 Re-mix paint in containers prior to and during application to ensure break-up of lumps, complete dispersion of settled pigment, and colour and gloss uniformity.

2.4 Gloss/Sheen Ratings

- .1 Paint gloss shall be defined as the sheen rating of applied paint, in accordance with the following values:

| Gloss Level Category/ | Units @ 60 deg / | Units @ 60 deg / |
|-----------------------|------------------|------------------|
| G1 - matte finish | 0 to 5 | max. 10 |
| G2 - velvet finish | 0 to 10 | 10 to 35 |

| Gloss Level Category/ | Units @ 60 deg / | Units @ 60 deg / |
|------------------------|------------------|------------------|
| G3 - eggshell finish | 10 to 25 | 10 to 35 |
| G4 - satin finish | 20 to 35 | min. 35 |
| G5 - semi-gloss finish | 35 to 70 | |
| G6 - gloss finish | 70 to 85 | |
| G7 - high gloss finish | > 85 | |

- .2 Gloss level ratings of painted surfaces shall be as specified herein.

2.5 Exterior Painting Systems

- .1 Cementitious Composition Board Surfaces: (vertical surfaces, horizontal soffits)
- .1 Latex MPI Gloss level 3 finish to MPI classification #15.
- .2 Structural Steel and Metal Fabrications:
- .1 Quick dry enamel MPI Gloss level 2 finish to MPI classification #81.
- .3 Dimension Lumber: timber columns, beams (portion visible).
- .1 Clear (2 component) polyurethane finish to meet MPI #78 product classification.
- .4 Dimension Lumber: columns (portion not visible).
- .1 Wood Preservative to meet MPI #37 product classification.
- .5 Metal (not aluminum): doors and frames.
- .1 Exterior Alkyd Enamel, Gloss, MPI Gloss Level 4 to meet MPI #9 product classification on metal primer.
- .6 Stucco: walls
- .1 Latex MPI Gloss level 4 finish (over alkali resistant primer).
- .2 Fabrishield PR-62 to 2440mm AFF as manufactured by Fabrikem, as supplied by I-XL (204) 284-1773.
- .7 Brick: walls from lowest portion of brick to 2440 above finished grade.
- .1 Fabrishield PR-61 as manufactured by Fabrikem as supplied by I-XL (204) 284-1773.

PART 3 EXECUTION

3.1 General

- .1 Perform preparation and operations for exterior painting in accordance with MPI Painting Specifications Manual except where specified otherwise.
- .2 Apply paint materials in accordance with paint manufacturer's written application instructions.

3.2 Protection

- .1 Protect existing building surfaces and adjacent structures from paint spatters, markings and other damage by suitable non-staining covers or masking. If damaged, clean and restore such surfaces as directed by Contract Administrator.
- .2 Protect items that are permanently attached such as Fire Labels on doors and frames.
- .3 Protect factory finished products and equipment.
- .4 Protect passing pedestrians about the building.
- .5 Removal of light fixtures, surface hardware on doors, and other surface mounted equipment, fittings and fastenings shall be done prior to undertaking painting operations by Contractor. Items shall be securely stored and re-installed after painting is completed by Contractor.

3.3 Cleaning and Preparation

- .1 Clean and prepare exterior surfaces in accordance with MPI Painting Specification Manual requirements. Refer to the MPI Manual in regard to specific requirements and as follows:
 - .1 Remove dust, dirt, and other surface debris by wiping with dry, clean cloths or compressed air.
 - .2 or any such organic solvents to clean up water-based paints.
- .2 Clean the following surfaces with high pressure water washing: oily residue.
- .3 Prevent contamination of cleaned surfaces by salts, acids, alkalis, other corrosive chemicals, grease, oil and solvents before prime coat is applied and between applications of remaining coats. Apply primer, paint, or pretreatment as soon as possible after cleaning and before deterioration occurs.
- .4 Where possible, prime surfaces of new wood surfaces before installation. Use same primers as specified for exposed surfaces.
 - .1 Apply vinyl sealer to MPI #36 over knots, pitch, sap and resinous areas.
 - .2 Apply wood filler to nail holes and cracks.
 - .3 Tint filler to match stains for stained woodwork.
- .5 Sand and dust between coats as required to provide adequate adhesion for next coat and to remove defects visible from a distance up to 1000 mm.
- .6 Clean metal surfaces to be painted by removing rust, loose mill scale, welding slag, dirt, oil, grease and other foreign substances in accordance with MPI requirements. Remove traces of blast products from surfaces, pockets and corners to be painted by brushing with clean brushes.
- .7 Touch up of shop primers with primer as specified in applicable section. Major touch-up including cleaning and painting of field connections, welds, rivets, nuts,

washers, bolts, and damaged or defective paint and rusted areas, shall be by supplier of fabricated material.

3.4 Application

- .1 Method of application to be as approved by Contract Administrator. Apply paint by brush and roller. Conform to manufacturer's application instructions unless specified otherwise.
- .2 Brush and Roller Application:
 - .1 Apply paint in a uniform layer using brush and/or roller of types suitable for application.
 - .2 Work paint into cracks, crevices and corners.
 - .3 Paint surfaces and corners not accessible to brush using spray, daubers and/or sheepskins.
 - .4 Paint surfaces and corners not accessible to roller using brush, daubers or sheepskins.
 - .5 Brush and/or roll out runs and sags, and over-lap marks. Rolled surfaces shall be free of roller tracking and heavy stipple unless approved by Contract Administrator.
 - .6 Remove runs, sags and brush marks from finished Work and repaint.
- .3 Use dipping, sheepskins or daubers only when no other method is practical in places of difficult.
- .4 Apply coats of paint as a continuous film of uniform thickness. Repaint thin spots or bare areas before next coat of paint is applied.
- .5 Allow surfaces to dry and properly cure after cleaning and between subsequent coats for minimum time period as recommended by manufacturer.
- .6 Sand and dust between coats to remove visible defects.
- .7 Finish surfaces both above and below sight lines as specified for surrounding surfaces, including such surfaces as projecting ledges.
- .8 Finish top, bottom, edges and cutouts of doors after fitting as specified for door surfaces.

3.5 Mechanical/Electrical Equipment

- .1 Unless otherwise specified, paint exterior exposed conduits, piping, hangers, ductwork and other mechanical and electrical equipment with colour and finish to match adjacent surfaces, except as noted otherwise.
- .2 Touch up scratches and marks on factory painted finishes and equipment with paint as supplied by manufacturer of equipment.
- .3 Do not paint over nameplates.

- .4 Paint fire protection piping red.
- .5 Paint steel electrical light standards unless pre-painted or anodized. Do not paint outdoor transformers and substation equipment.

3.6 Field Quality Control

- .1 Advise Contract Administrator when each surface and applied coating is ready for inspection. Do not proceed with subsequent coats until previous coat has been approved.

END OF SECTION

PART 1 GENERAL

1.1 Related Sections

- .1 Section 05500 - Metal Fabrications: Suspended channel support for ceiling hung partitions.
- .2 Section 10800 – Toilet, Bath, and Laundry Accessories.

1.2 References

- .1 American Society for Testing and Materials (ASTM)
 - .1 ASTM A 167-99, Specification for Stainless and Heat-Resisting Chromium-Nickel Steel Plate, Sheet, and Strip.
- .2 Canadian General Standards Board (CGSB)
 - .1 CAN/CGSB-1.88-92, Gloss Alkyd Enamel Air Drying and Baking.
 - .2 CAN/CGSB-1.104M-91, Semigloss Alkyd, Air Drying and Baking Enamel.
 - .3 CAN/CSA-B651-95, Barrier-Free Design.

1.3 Shop Drawings

- .1 Submit shop drawings in accordance with Section 01330 - Submittal Procedures.
- .2 Indicate fabrication details, plans, elevations, hardware, and installation details.

1.4 Waste Management and Disposal

- .1 Collect and separate plastic, paper packaging and corrugated cardboard in accordance with Waste Management Plan.
- .2 Fold up metal banding, flatten and place in designated area for recycling.

PART 2 PRODUCTS

2.1 Materials

- .1 Plastic toilet partitions – solid core, floor mounted and overhead braced.
 - .1 Acceptable material: Comtec series S200, Capitol Partitions Poly-Pro P3 – Congress Basic, Santana Poly-Mar HD or approved equal.
- .2 Attachment: stainless steel tamperproof type screws and bolts.

2.2 Components

- .1 Hinges:
 - .1 Material/finish: stainless steel casting.

- .2 Swing: inward at typical stalls, outward at barrier free stalls.
- .3 Return movement: gravity or approved equal.
- .2 Latch set: surface mounted, combination latch, door-stop, keeper and bumper, stainless steel.
- .3 Wall and connecting brackets: stainless steel extrusion or casting.
- .4 Coat hook: one per stall, combination hook and rubber door bumper, stainless steel, door mounted.
- .5 Door pull: Barrier-free type suited for out swinging doors, stainless steel.
- .1 On all accessible stalls provide pull handles on interior.

2.3 Fabrication

- .1 Doors, panels and screens: 25 mm thick, HDPE, to sizes indicated.
- .2 Pilasters: 25 mm thick, constructed same as door, to sizes indicated.
- .3 Provide formed and closed edges for doors, panels and pilasters.
- .4 At accessible stalls, door width shall be between 915 and 925mm.

2.4 Finishes

- .1 Finish: doors and pilaster/panels same colour as selected from manufacturer's standard colours, total 2 colours for project.

PART 3 EXECUTION

3.1 Installation

- .1 Ensure supplementary anchorage, if required, is in place.
- .2 Do Work in accordance with CAN/CSA-B651.

3.2 Erection

- .1 Partition erection.
 - .1 Install partitions secure, plumb and square.
 - .2 Leave 12 mm space between wall and panel or end pilaster.
 - .3 Anchor mounting brackets to masonry/concrete surfaces using screws and shields: to hollow walls using bolts and toggle type anchors, to steel supports with bolts in threaded holes.
 - .4 Attach panel and pilaster to brackets with through type sleeve bolt and nut.

- .5 Provide for adjustment of floor variations with screw jack through steel saddles made integral with pilaster. Conceal floor fixings with stainless steel shoes.
- .6 Equip each door with hinges, latch set, and each stall with coat hook mounted on door, mounting heights as indicated on drawings and details. Adjust and align hardware for easy, proper function. Set door open position at full open. Install door bumper door mounting, type integral with coat hook.
- .7 Equip out swinging doors with door pulls on inside and outside of door in accordance with CAN/CSA-B651.
- .8 Install hardware grab bars.
- .2 Floor supported partition erection.
 - .1 Secure pilasters to floor with pilaster supports anchored with minimum 50 mm penetration in structural floor.
 - .2 Level, plumb and tighten installation with leveling device.
 - .3 Secure pilaster shoes in position.
 - .4 Set tops of doors level with tops of pilasters when doors are in closed position.

END OF SECTION

PART 1 GENERAL

1.1 Related Sections

- .1 Section 01330 - Submittal Procedures.
- .2 Section 01355 - Waste Management and Disposal.
- .3 Section 08800 - Glazing: Mirrors.

1.2 References

- .1 American Society for Testing and Materials (ASTM)
 - .1 ASTM A167-99, Standard Specification for Stainless and Heat-Resisting Chromium-Nickel Steel Plate, Sheet, and Strip.
 - .2 ASTM B456-95, Standard Specification for Electrodeposited Coatings of Copper Plus Nickel Plus Chromium and Nickel Plus Chromium.
 - .3 ASTM A653/A653M-99, Standard Specification for Steel Sheet, Zinc-Coated (Galvanized) or Zinc-Iron Alloy-Coated (Galvanealed) by the Hot-Dip Process.
 - .4 ASTM A924/A924M-99, Standard Specification for General Requirements for Steel Sheet, Metallic-Coated by the Hot-Dip Process.
- .2 Canadian General Standards Board (CGSB)
 - .1 CAN/CGSB-1.81-M90, Air Drying and Baking Alkyd Primer for Vehicles and Equipment.
 - .2 CAN/CGSB-1.88-92, Gloss Alkyd Enamel, Air Drying and Baking.
 - .3 CAN/CGSB-12.5-M86, Mirrors, Silvered.
 - .4 CGSB 31-GP-107Ma-90, Non-inhibited Phosphoric Acid Base Metal Conditioner and Rust Remover.
- .3 Canadian Standards Association (CSA)
 - .1 CAN/CSA-B651-95, Barrier-Free Design.
 - .2 CAN/CSA-G164-M92, Hot Dip Galvanizing of Irregularly Shaped Articles.

1.3 Shop Drawings

- .1 Submit shop drawings in accordance with Section 01330 - Submittal Procedures.
- .2 Indicate size and description of components, base material, surface finish inside and out, hardware and locks, attachment devices, description of rough-in-frame, building-in details of anchors for grab bars.

1.4 Closeout Submittals

- .1 Provide maintenance data for toilet and bath accessories for incorporation into manual specified in Section 01780 - Closeout Submittals.

1.5 Waste Management and Disposal

- .1 Separate and recycle waste materials in accordance with Section 01355 - Waste Management and Disposal.
- .2 Collect and separate plastic, paper packaging and corrugated cardboard in accordance with Waste Management Plan.

1.6 Extra Materials

- .1 Provide special tools required for accessing, assembly/disassembly or removal for toilet and bath accessories in accordance with requirements specified in Section 01780 - Closeout Submittals.
- .2 Deliver special tools to Contract Administrator.

PART 2 PRODUCTS

2.1 Materials

- .1 Sheet steel: to ASTM A653/A653M with ZF001 designation zinc coating.
- .2 Stainless steel sheet metal: to ASTM A167, Type 302 or 304.
- .3 Stainless steel tubing: Type 302 or 304, commercial grade, seamless welded, 1.2 mm wall thickness minimum.
- .4 Fasteners: concealed screws and bolts hot dip galvanized, exposed fasteners to match face of unit. Expansion shields fibre, lead or rubber as recommended by accessory manufacturer for component and its intended use.

2.2 Components (refer to interior elevations for quantities)

- .1 Feminine napkin disposal bin:
 - .1 Acceptable material: Bobrick B270.
- .2 Grab bars: Grab bar material and anchorage to withstand downward pull of 2.2 kN.
 - .1 Acceptable material: (In stalls) Frost 1001D36", Bobrick B550 x 36 and Frost 1001D24", Bobrick B550 x 24.
 - .2 Acceptable material: (at urinals) Frost 1001D12", Bobrick B5507 x 12.
- .3 Diaper changing station: surface mounted wall unit.
 - .1 Acceptable material: Frost 1125, Bobrick B-2200.

- .4 Collapsible clothes hooks.
 - .1 Acceptable material: Bobrick B-981 or approved equal.
- .5 Electric Hand Dryers.
 - .1 Acceptable material: Bobrick B-740 or Ouellet model OSM-1, color: white or approved equal.

2.3 Fabrication

- .1 Weld and grind joints of fabricated components flush and smooth. Use mechanical fasteners only where approved.
- .2 Wherever possible form exposed surfaces from one sheet of stock, free of joints.
- .3 Brake form sheet metal Work with 1.5 mm radius bends.
- .4 Form surfaces flat without distortion. Maintain flat surfaces without scratches or dents.
- .5 Back paint components where contact is made with building finishes to prevent electrolysis.
- .6 Hot dip galvanize concealed ferrous metal anchors and fastening devices to CSA G164.
- .7 Shop assemble components and package complete with anchors and fittings.
- .8 Deliver inserts and rough-in frames to job site at appropriate time for building-in. Provide templates, details and instructions for building in anchors and inserts.
- .9 Provide steel anchor plates and components for installation on studding and building framing.

2.4 Finishes

- .1 Chrome and nickel plating: to ASTM B456, satin finish.
- .2 Baked enamel: condition metal by applying one coat of metal conditioner to CGSB 31-GP-107Ma, apply one coat Type 2 primer to CAN/CGSB-1.81 and bake, apply two coats Type 2 enamel to CAN/CGSB-1.88 and bake to hard, durable finish. Sand between final coats. Colour selected from standard range by Contract Administrator.

PART 3 EXECUTION

3.1 Installation

- .1 Install and secure accessories rigidly in place as follows:
 - .1 Stud walls: install steel back-plate to stud prior to plaster or drywall finish. Provide plate with threaded studs or plugs.
 - .2 Hollow masonry units or existing plaster/drywall: use toggle bolts drilled into cell/wall cavity.
 - .3 Solid masonry, marble, stone or concrete: use bolt with lead expansion sleeve set into drilled hole.
 - .4 Toilet/shower compartments: use male/female through bolts.
- .2 Install grab bars on built-in anchors provided by bar manufacturer.
- .3 Use tamper proof screws/bolts for fasteners.
- .4 Fill units with necessary supplies shortly before final acceptance of building.
- .5 Install mirrors in accordance with Section 08800 - Glazing.
- .6 Install City supplied items: wall mounted soap dispensers and washroom stall toilet tissue dispensers.

3.2 Schedule

- .1 Locate accessories where indicated on drawings and details.
- .2 Feminine napkin disposal bin: one in each female toilet compartment mounting height as indicated on drawings and details.
- .3 Hand dryer: quantity as indicated in each public washroom. Maximum height of dispenser and operable part from floor 1200 mm to meet Universal Design Standards.
- .4 Grab bar: two in each handicapped toilet compartment. Height of grab bar from floor as indicated on drawings and details. Side grab bar: maximum distance from rear wall 300 mm, minimum distance passed front edge of toilet 450 mm.
- .5 Diaper changing station: as indicated on drawings and details. Refer to drawings and details for mounting height.

END OF SECTION

Part 1 General

1.1 RELATED WORK

- .1 Section 06100- Rough Carpentry - Blocking and backing for attachment of items specified in this section.

1.2 REGULATORY REQUIREMENTS

- .1 All items supplied are to be CSA approved.

1.3 SUBMITTALS

- .1 Submit shop drawings and product data to requirements of Section 01330.
- .2 Submit operation and maintenance data to requirements of Section 01330.

Part 2 Products

2.1 FIRE EXTINGUISHERS

- .1 Supply and install Fire extinguishers to meet the requirements of the Manitoba Fire Code, including all the amendments issued after publication. Fire extinguishers shall be 4.5 kg., A.B.C multi purpose type, in semi-recessed cabinets ABC Model C-950-1 to be semi-recessed in stud wall. Provide 4 units.
- .2 Location: as per Main Floor Plan.

2.2 SPLASHPADS

- .1 Precast concrete, 1220 x 280 x 76 mm. at each downspout and sump discharge c/w anchor pin as manufactured by Barkman or approved equal.

2.3 DRESSING ROOM SAFETY COAT HOOKS

- .1 Single coat hook – color: white as manufactured by Frost, model number 1150. Quantity as indicated on interior elevations.

2.4 COUNTER SHUTTERS

- .1 As supplied by Shanahan's or approved equal, steel counter shutters or aluminum (see specifications Section 08330 Rolling Shutters), based on Cookson CD-10 Standard Steel Counter shutter, Tan Cote finish, manual push up operation, cylinder locks, F.O.W. mounted. 1 @ 2400 wide x 1220 high, 2 @ 1500 wide x 1220 high, 1 @ 1800 wide x 1220 high – confirm dimensions on site.
- .2 As supplied by Shanahan's or approved equal, steel counter shutters or aluminum (see specifications Section 08330 Rolling Shutters), based on Cookson CD-10 Standard Steel Counter shutter, Tan Cote finish, manual push up operation, provide receptor for latch locks, F.O.W. mounted. 1 @ 1800 wide x 1220 high – confirm dimensions on site.

2.5 ACOUSTIC PANELS

- .1 Manufactured by Tectum or Martin AcoustiPlank (Dennis 1-877-226-8789), prefinished white, 25mm thick, beveled edge. Refer to Part 3 – Execution for installation.

2.6 ICE FLOODING HOSE

- .1 Quantity 90m, (25mm dia.) rubber watering hose, black, reinforced construction for heavy duty winter use.
 - .1 Acceptable product: (as supplied by Allsips, Evenspray, or similar)
 - .2 Final product to be approved by City of Winnipeg Public Works.

2.7 INTERIOR SIGNAGE

- .1
 - .1 Ten (10) signs total at the following rooms: Office, Multi Purpose Room, Dressing Room 1, Dressing Room 2, Dressing Room 3, Dressing Room 4, Dressing Room 5, Dressing Room 6, Referee Room, Janitor Room. Mount signage 1350mm from finished floor to centerline sign. Signage color MB-17 Aluminum Satin text with background color in Metalbrite finishes. Sans-serif with Arabic numerals or approved equal. Text to be tactile with Braille Grade 2 in the lower right corner of sign. Mount on wall adjacent to door on the latch side, within 150mm of the doorjamb. Signage to be in upper and lower case. Characters to be 25mm high. Mounting with screws. Plaque format to be 12.12.0 by Insign, Preside Sign Systems, or approved equal.
 - .2 Washroom signage. Pictograph shall be raised with Grade 2 Braille in the lower right corner. Signage color to be MB-17 Aluminum Satin image with background color in Metalbrite finishes. "Men" and "Women" shall be written in raised characters underneath the pictograph. Characters shall be 25mm in height, in Sans-serif. Mounting with screws. Plaque format to be 7.7.0 by Insign, Preside Sign Systems, or approved equal.

2.8 EXTERIOR SIGNAGE

- .1
 - .1 Material : Cut Aluminum 13mm thick, height to be 800mm.
 - .2 Mounting: Projected stud mount #1, 13mm projection, c/w construction adhesive at mounting screws.
 - .3 Style: Colour lettering with automotive type enamel from full palette. Allow one colour. Lettering to be Gadget Bold upper case.
 - .4 Description: to read "RED RIVER COMMUNITY CENTRE"
- .2
 - .1 Material : Cut Aluminum 13mm thick, height to be 150mm.
 - .2 Mounting: Projected stud mount #1, 13mm projection, c/w construction adhesive at mounting screws.
 - .3 Style: Colour lettering with automotive type enamel from full palette. Allow one colour. Lettering to be Gadget Bold upper case.
 - .4 Description: to read "293 MURRAY AVE."
- .3 Accessible Parking Stall Signage
 - .1 Material: black and white color aluminum sign, 12" x 18" c/w accessible symbol mounted on galvanized steel post embedded in ground 900mm, sign mounted 1220mm above grade.
 - .2 Locations: as indicated on drawings.

2.9 ENTRANCE MAT

- .1 Material: Gateway Entrance Matting, Solid PVC Grid, 14mm deep complete with aluminum "J" channel frame to suit overall size and aluminum mat dividers as required. Orient ribs perpendicular to traffic flow. Color chosen after Contract award from standard colors. Mat width to be as indicated on drawings. As manufactured by Gerrard Ovalstrapping (905) 632-3662 or approved equal.

2.10 GYMNASIUM EQUIPMENT

- .1 Side Folding Basketball Backstop
 - .1 Supply and install:
 - .1 RS 119 HD Backstop, as manufactured by Kodiak Industries, Winnipeg, MB and supplied by Royal Stewart Ltd, or approved equal.
 - .2 RS 116 adjustable frame shall be made of 2" (51mm) square tubing and mounted to the wall by means of 1/4" x 4" (6mm x 102mm) steel plates 35" (889mm) o.c.
 - .3 Stabilizing bars shall be made using 2" (50mm) tubing and run from the front of the backstop frame up to the wall in a 30 degree angle.
 - .4 Stabilizers shall be hinge mounted to allow for minor adjustment. Cable bracing shall not be permitted.
 - .5 Backstop shall have a built-in spring-loaded locking bar. Release handle shall be supplied.
 - .6 Backstop framework shall be painted flat black.
 - .7 Wall bolts shall be supplied as indicated on the shop drawings for installation by others.
 - .8 Backstop shall be equipped with RS 94 steel rectangular backboard and RS 2000 breakaway goal with zinc plated steel chain net.
 - .2 Floor Sockets
 - .1 Supply and install:
 - .1 RS 100 Sockets shall be cast bronze, machined to 1.93" (49mm) ID and to be supplied complete with drop in caps, or approved equal.

Part 3 Execution

3.1 INSPECTION

- .1 Verify that surfaces and internal wall blocking are ready to receive Work and opening dimensions are as instructed by the manufacturer.
- .2 Beginning of installation means acceptance of substrate conditions.

3.2 INSTALLATION

- .1 Install in accordance with manufacturer's instructions.
- .2 Acoustic panels to be installed with adhesive and mechanically fastened.

END OF SECTION

1.1 GENERAL

- .1 All drawings and all sections of the specifications shall apply to and form an integral part of this section.

1.2 SCOPE OF WORK

- .1 Work to include all labour, material and equipment required for installing, testing and placing in initial operation the following systems as detailed in specifications of each section and as shown on drawings.
 - .1 Section 15051 Acceptable Materials & Equipment
 - .2 Section 15180 Insulation
 - .3 Section 15300 Site Services
 - .4 Section 15400 Plumbing
 - .5 Section 15600 Liquid Heat Transfer
 - .6 Section 15800 Air Distribution
 - .7 Section 15900 Controls/Instrumentation
 - .8 Section 15990 Testing, Adjusting and Balancing
- .2 All Mechanical Work to be bid as a single complete bid even though Work of various mechanical trades has been further sub-divided into each Section noted above.

1.3 SITE SERVICE INFORMATION

- .1 Location, routing and depth of existing mechanical services shown on drawings are based on recorded information and are approximate only. Contractor shall verify exact location at jobsite.
- .2 Avoid damaging or displacing existing services where exact position is not known. Should any damage occur, advise Contract Administrator in writing for remedial instructions.

1.4 REGULATIONS

- .1 Comply with, most stringent requirements of Manitoba Building Code, National Building Code and local regulations and by-laws, with specified standards and codes and this specification. Before any Work is proceeded with, approved layouts to be filed with and approved by proper authorities.
 - .2 Provide necessary notices, obtain permits and pay all fees, in order that Work specified may be carried out. Charges and alterations required by authorized inspector of any authority having jurisdiction, to be carried out without charge or expense to The City. Pay all charges for service connections to municipal mains.
-

- .3 Furnish certificates confirming Work installed conforms to requirements of authorities having jurisdiction.

1.5 LIABILITY

- .1 Install Work in advance of concrete pouring or similar Work. Provide and set pipe sleeves as required.
- .2 Install concealed pipes and ducts neatly, close to building structure so furring is minimum size. Pipes, ducts and equipment installed improperly, to be removed and replaced without cost to The City.
- .3 Protect and maintain Work until building has been completed and accepted. Protect Work against damage during installation. Cover with tarpaulins if necessary. Repair all damage to floor and wall surfaces resulting from carrying out Work, without expense to The City.
- .4 During welding or soldering ensure structure is protected against fire, shield with fire-rated sheets and galvanized iron sheets. Mount portable fire extinguishers in welding or soldering areas.
- .5 Co-ordinate Work with other sections to avoid conflict and to ensure proper installation of all equipment. Review all Contract drawings.
- .6 On completion of Work, remove tools, surplus and waste material and leave Work in clean, perfect condition.

1.6 GUARANTEE

- .1 Guarantee satisfactory operation of all Work and apparatus installed under this Contract. Replace, at no expense to The City, all items which fail or prove defective within a period of one year after final acceptance of complete Contract by The City, always provided such failure is not due to improper usage by The City. Make good all damage to building incurred as a result of failure or repair of mechanical Work.
 - .2 No certification given, payment made, partial or entire use of equipment by The City, shall be construed as acceptance of defective Work or acceptance of improper materials. Make good at once, without cost to The City all such defective Work or materials and consequence resulting therefrom, within one year of final acceptance date.
 - .3 This general guarantee shall not act as a waiver for any specified guarantee and/or warranty of greater length of time noted elsewhere in these documents.
-

- .4 Domestic hot water tanks shall have manufacturer's warrantee for period of (5) five years.
- .5 Plumbing brass shall have manufacturer's warrantee for period of five (5) years.
- .6 Refrigeration compressor circuit connected to air-conditioning systems shall have manufacturer's warrantee period of four (4) years after initial one year guarantee.

1.7 CONTRACT ADMINISTRATOR OBSERVATIONS

- .1 The Contract Administrator will appoint a representative from SMS Engineering Ltd. to observe all Work of Division 15 and 16 after Contract Award. SMS Engineering Ltd.
770 Bradford Street
Winnipeg, Manitoba
R3H 0N3
- .2 Contractor's Work will be observed periodically by The City, and/or Contract Administrator or their representatives, solely for purpose of determining general quality of Work, and not for any other purpose. Guidance will be offered to Contractor in interpretation of plans and specifications to assist him to carry out Work. Observations and directives given to Contractor does not relieve Contractor and his agents, servants and employees of their responsibility to erect and install Work in all its parts in a safe and workmanlike manner, and in accordance with plans and specifications, nor impose upon The City, and/or Contract Administrator or their representatives, any responsibility to supervise or oversee erection or installation of any Work.

1.8 WELDING REGULATIONS

- .1 Do not weld when temp. of base metal is lower than -17 deg. C except with consent of Contract Administrator . At temp. below 0 deg. C, surface of all areas within 75mm (3") of point where weld is to be started to be heated to temp. at least warm to hand before welding is commenced. At all temperatures below +4 deg. C, operator and Work to be protected against direct effect of wind and snow.
 - .2 Welding shall be performed by welder holding current welder's certificate from Provincial Department of Labour.
 - .3 Comply with CSA W117.2 "Safety in Welding, Cutting, and Allied Processes".
-

1.9 MECHANICAL SHOP DRAWINGS

- .1 Submit for review a minimum of six sets of detailed shop drawings. Refer to Section 15051 "Acceptable Materials & Equipment" for shop drawings requirements.
- .2 Check shop drawings for conformity to plans and specifications before submission.
- .3 Each drawing to bear a signed stamp including project name and Contractor's Firm name verifying drawings have been checked prior to submission to Contract Administrator . Signature of stamp shall signify the Contractor has checked and found all dimensions to be compatible with the Contract drawings and all capacities, quantities, sizes and other data contained in the Contract documents have been listed by the supplier on the drawings and have been checked by the undersigned and found correct.
- .4 Clearly show division of responsibility. No item, equipment or description of Work shall be indicated to be supplied or Work to be done "By Other's or By Purchaser". Any item, equipment or description of Work shown on shop drawings shall form part of Contract, unless specifically noted to contrary.
- .5 Take full responsibility for securing and verifying field dimensions. In case where fabrication must proceed prior to field dimensions being available, check all shop drawings and approve for dimensions only. In this case guarantee that dimensions will be worked to and ensure that other sub-trades are aware of these dimensions and shall comply to them.
- .6 Review by Contract Administrator shall be mutually understood to refer to general design only. If errors in detailed dimensions or interference with Work are noticed, attention of Contractor will be called to such errors of interferences, but Contract Administrator 's review of drawings will not in any way relieve Contractor from responsibility for said errors or interferences, or from necessity of furnishing such Work, and materials as may be required for completion of Work as called for in Contract Documents.

1.10 MECHANICAL SUB-TRADES

- .1 Provide names of all sub-trades to be used in Work. Also, state extent of any Work so sublet. Request and receive Contract Administrator 's approval in writing, of all sub-trades for such Work before placing sub-trade Contract.
 - .2 Contractor to have minimum five years experience in field of mechanical contracting and to have successfully performed Work of similar nature and approximate size to that indicated in specifications and on drawings. Sub-trades shall employ, on this
-

project, foremen or supervisory personnel who have had similar experience to that required of Contractor.

1.11 DRAWINGS

- .1 Drawings are diagrammatic only and do not show all details. Information involving accurate measurements of building to be taken from Architectural Drawings and/or at building. Make, without additional expense to The City, all necessary changes or additions to runs to accomodate structural conditions. Locations of pipes, ducts and other equipment to be altered without charge to The City, provided change is made before installation and does not necessitate additional materials and that all such changes are ratified by Contract Administrator , recorded on Record Set of Drawings.
 - .2 Drawings and specifications to be considered as an integral part of Contract Documents. Neither drawings nor specifications to be used alone. Misinterpretation of requirements of plans or specifications shall not relieve Contractor of responsibility of properly completing Work to approval of Contract Administrator .
 - .3 As Work progresses and before installing piping, ductwork, fixtures and equipment interfering with interior treatment and use of building, consult Contract Administrator for comments. This applies to all levels and proper grading of piping. If Contractor fails to perform above checking and fails to inform Contract Administrator of such interference, Contractor to bear all subsequent expense to make good the installation.
 - .4 Drawings indicate general location and route to be followed by pipes and ducts. Where required pipes and/or ducts are not shown on plans or only shown diagrammatically, install in such a way as to conserve head room and interfere as little as possible with free use or space through which they pass.
 - .5 Contractor shall supply and install all additional plumbing fixtures noted on architectural drawings but not on mechanical drawings. Provide all necessary piping, fittings, accessories required for complete operation of such fixtures. Check all architectural drawings during bidding period.
 - .6 Spaces reserved for equipment noted as "future" or future extension to buildings, to be left clear as noted on drawings so that future connections can be made.
 - .7 Refer to Architectural Drawings for roof construction details. These shall relate to roof supports, piping penetrating roofs, etc. as indicated on mechanical detail sheets.
-

1.12 MATERIALS

- .1 Materials and equipment specified and acceptable manufacturers are named in this specification for the purpose of establishing the standard of materials and workmanship to which Contractor shall adhere. Bid price shall be based on the use of materials and equipment as specified.

- .2
 - .1 Materials of same general type to be of same manufacture (e.g. all air supply units shall be of same manufacturer). Contractor to ensure that all sub-trades provide products of same manufacturer.
 - .1 Follow manufacturer's recommendations for safety, adequate access for inspection, maintenance and repairs of individual equipment installed.
 - .2 Permit equipment maintenance and disassembly with minimum disturbance to connecting piping and duct systems and without interference with building structure or other equipment.
 - .3 Provide accessible lubricating means for bearings, including permanent lubricated 'Lifetime' bearings.

- .3 Equipment listed as 'equal' in specifications or submitted as alternate by Contractor must meet all space requirements, specified capacities and must have equipment characteristics of specified equipment as interpreted by Contract Administrator . Install equipment in strict accordance with manufacturer's published recommendations.

- .4 Equipment and materials shown on drawings and not specified herein, or specified herein and not shown on drawings, shall be included in this Contract as though both shown and specified.

1.13 ELECTRIC MOTORS, STARTERS AND WIRING

- .1 Provide electric motors for all equipment supplied in this Division. Motors to operate at 29 r/S (1800 rpm), unless noted otherwise. Motor design shall comply with Canadian Electrical Code requirements. All electric motors supplied shall be capable of being serviced locally.

 - .2 All three phase motors shall have a service factor of 1.15 times nominal rated horsepower of the motor.

 - .3 Operating voltages: to CAN3-C235-83, motors, electric heating, control and distribution devices and equipment to operate satisfactorily at 60 Hz within normal operating limits established by above standard. Equipment to operate in extreme operating conditions established in above standard without damage to equipment.
-

- .4 Motors controlled by variable frequency drives (VFDs) shall comply with requirements of CSA Specification C22.2 No. 100-95, Clause 12.4 and shall be permanently marked with the following in addition to the normal marking requirements:
- .1 Machine Application (Inverter Duty);
 - .2 Speed range over which the machine is designed to operate;
 - .3 Type of torque application for which the machine is designed (e.g. VT (variable torque), CT (constant torque), Chp (constant horsepower) or equivalent);
 - .4 Type(s) of inverter(s) with which the machine is intended to be used [e.g.: VSI or VVI (6-step voltage source), CSI (6-step current source), VPWM (voltage-source pulse width modulated), LCI (load commutated), cyclonverter, or equivalent].
- .5 Motors 0.75 kW (1 hp) and larger shall be high efficiency motors as defined in CSA C390 or IEEE 112B Nominal Standards. Minimum efficiency (%) shall be per the following table.

| kW | Minimum efficiency (%) | | | |
|-------|------------------------|----------|----------|---------|
| | 3600 RPM | 1800 RPM | 1200 RPM | 900 RPM |
| .75 | 79.0 | 82.4 | 81.1 | 74.4 |
| 1.11 | 81.0 | 82.8 | 83.8 | 76.8 |
| 1.50 | 81.7 | 83.8 | 84.4 | 83.8 |
| 2.24 | 84.6 | 86.1 | 86.4 | 83.6 |
| 3.73 | 86.4 | 86.9 | 87.2 | 85.4 |
| 5.60 | 87.4 | 88.4 | 88.2 | 86.2 |
| 7.46 | 88.4 | 89.4 | 88.6 | 88.6 |
| 11.19 | 89.3 | 90.1 | 89.0 | 88.0 |
| 14.92 | 89.7 | 90.9 | 89.8 | 89.8 |
| 18.65 | 90.0 | 91.1 | 90.9 | 89.6 |
| 22.38 | 90.6 | 91.5 | 91.1 | 90.3 |
| 29.84 | 91.0 | 92.0 | 91.6 | 90.1 |

List information on shop drawing submittals

- .6 Determine from electrical drawings and specifications, voltage characteristics applying to each individual motor. Where motor voltages are mentioned in this specification, confirmation to be made by reference to electrical drawings and specifications ordering motors.
- .7 Division 16 - Electrical to provide starters for all motors, except as otherwise noted. Division 16 - Electrical shall wire from starters to motors.
- .8 Wiring required between starters and switching apparatus such as wiring from starters to float switches, pressure switches and all control wiring to be by Division 16 - Electrical except as noted otherwise on drawings and in specifications. Provide proper terminal connections and lead wires at motors and other apparatus ready for connection by Division 16 - Electrical. Provide Division 16 - Electrical with accurate locations of electrical connection points and all necessary schematic and other drawings to facilitate electric Work.

.9 Wiring required under Section 15900 to be performed by Section 15900 except as noted otherwise. Refer also to Section 15900 for further requirements.

.10

.1 Division 16 - Electrical to perform all wiring and make final connections to all controls for roof-top HVAC units and all mechanical equipment where controls are supplied with equipment.

.2 Division 15 shall provide wiring diagrams indicating all power and control wiring requirements.

.11 Division 16 - Electrical to perform all wiring and make final connections to all controls for air cooled condensing units. Refer to Clause "Refrigeration Piping and Accessories".

.12 Division 15 shall provide wiring diagrams indicating all power and control wiring requirements for equipment supplied by Division 15.

1.14 IDENTIFICATION OF VALVES

.1 Provide engraved lamacoid color coded tags secured to items with non-ferrous chains or "S" hooks. Use for valves and operating controllers of all systems. Consecutively number valves in each piping system i.e. domestic water, steam, etc.

.2 Provide one plastic laminated copy and secure to mechanical room wall where instructed. Place one copy in each maintenance instruction manual.

.3 Identify controls and gauges by labels of 3mm (1/8") plastic engraving stock with white lettering on black background. Size approximately 62mm x 25mm (2-1/2" x 1") high.

1.15 HANGERS AND SUPPORTS

.1 General

.1 Piping, ductwork and equipment shall be securely supported from building structure. Perforated strap or wire hangers are not permitted.

.2 Support components shall conform to Manufacturers Standardization Society Specification SP-38.

.2 Installation - Horizontal

.1 Hangers shall adequately support piping system. Locate hangers near or at changes in piping direction and concentrated loads. Provide vertical adjustment to maintain pitch required for proper drainage. Allow for piping expansion and contraction. Piping weight and stresses shall be supported independently of any equipment.

- .2 Maximum spacing between pipe supports:
 - .1 Steel Pipe:
 - .1 Up to 50mm (2") diam. - 2.4m (8 ft.)
 - .2 62mm (2-1/2") and larger - 3.6m (12 ft.)
 - .2 Copper Tubing (Hard):
 - .1 Up to 25mm (1") diam. - 1.8m (6 ft.)
 - .2 32mm and larger - 2.4m (8 ft.)
 - .3 Cast Iron Pipe
 - .1 Maximum spacing - in accordance with Plumbing Code. Locate hangers adjacent to hubs or joints.
 - .2 Support M.J. pipe on both sides of joint. Provide with sway braces and anchors to Contract Administrator's approval. At multiple fittings or short lengths provide sufficient hangers to support all joints to Contract Administrator's satisfaction.
 - .4 Plastic Pipe As recommended by manufacturer.
 - .3 Installation - Vertical Piping
 - .1 Support vertical pipes at each floor by Grinnell Fig. 261 riser clamps. Locate clamps immediately below coupling if possible. Support soil pipe at hub. Brace risers up to 50mm (2") size at intervals not over 2.13m (7'). Support base in approved manner.
 - .4 Structural Attachments
 - .1 To Concrete:
 - .1 Place inserts in structural floors for support of piping and equipment prior to pouring of concrete. Inserts in concrete slabs shall be Grinnell Fig. 285 Light Weight Concrete Insert for loads up to 182 Kg (400#) or Grinnell Fig. 281 Wedge type concrete insert for loads up to 544 Kg (1200#).
 - .2 Support hangers in corrugated steel deck by 50mm (2") piece of 3mm (1/8") thick steel plate placed across top of steel deck, secured to hanger rod by washer and nut; prior to pouring of concrete topping.
 - .3 Where inserts must be placed in existing concrete use Hilti H.D.I. steel anchors as recommended by manufacturer, or if heavy weights must be supported, drill hole through slab and provide 50mm x 50mm (2" x 2") washer and nut above rough slab before floor finish is poured.
 - .2 To Steel Beams:
 - .1 Where pipe size is 50mm (2") or less, use Grinnell Fig. 87 Malleable Iron C-Clamp and Retaining Clip, or equal.
 - .2 Where pipe size is over 50mm (2"), use Grinnell Fig. 229 Malleable Beam Clamp or Fig. 228 Forged Steel Beam Clamp.
 - .3 To Wooden Ceilings and Beams:
 - .1 Use Grinnell Fig. 153 Pipe Hanger Flange or Fig. 156 or equal.
 - .4 Miscellaneous:
 - .1 Provide suitable attachments equal in quality to above where required.
-

.5 Hangers and Supports

- .1 Steel Pipe: Up to 50mm (2") - Grinnell Fig. 65 light clevis - size to suit O.D. of pipe. 62mm (2-1/2") and larger - Fig. 260 clevis - size to suit O.D. of insulation.
- .2 Copper Tubing (Hard):
 - .1 Up to 50mm (2") - Grinnell CT65 copper plated clevis - size to suit O.D. of pipe. Fig. 65 may be used if isolation is provided - see below.
 - .2 62mm (2-1/2") and larger - Fig. 260 clevis - size to suit O.D. of insulation - on uninsulated pipe provide isolation as specified below.
- .3 Cast Iron Pipe:
 - .1 All sizes - Fig. 260 clevis - size to suit O.D. of pipe.
- .4 Plastic and Other Types of Piping: Support as recommended by manufacturer.
- .5 Provide fabricated steel supports as detailed on drawings or as required to adequately support piping and equipment. Details to be approved by Contract Administrator . Supports shall be of welded construction except where adjustment is required.
- .6 Where thermal expansion in excess of 12mm (1/2") axially is anticipated, or where indicated, use Grinnell Fig. 171 Adjustable Pipe Roll or Grinnell Fig. 271 Pipe Roll Stand.
- .7 For vertical piping support, use Grinnell Fig. 261 clamp. For vertical copper piping, use Fig. CT-121-C.
- .8 Above indicates general requirements. Provide hangers and supports of equal quality to suit job requirements where not covered by the above.
- .9 Support groups of horizontal pipes by angle iron trapeze hangers.
- .10 Rollers and chairs shall not be installed on trapeze hangers.
- .11 Several individual hanger rods may be supported from a trapeze or individual inserts in concrete slab.
- .12 Hangers to be adjustable after pipe is in place. Parts must be of adequate strength for weight to be supported with safety factor of 5 to 1.
- .13 Hanger Rod:
 - .1 Support hangers with mild steel rod. Load on hanger not to exceed capacity indicated in following table:
 - .2 Rod Diam. Max. Safe Load
 - .1 9.5mm(3/8") 277 Kg(610 lbs.)
 - .2 13mm(1/2") 514 Kg(1130 lbs.)
 - .3 16mm(5/8") 822 Kg(1818 lbs.)
 - .4 19mm(3/4") 1232 Kg(2710 lbs.)
 - .3 Rods to have sufficient threaded length to allow for vertical adjustment after pipe is in place. Use two nuts in each rod, one above clevis or angle iron, and one below.

.6 Isolation

- .1 Copper piping shall be isolated from steel supports by copper plated hangers, plastic coated hangers, tinning pipe at supports, or provision of suitable lead or copper isolators.

Where no pipe movement or abrasion is expected, suitable plastic electricians tape may be wrapped around pipe at hangers.

.7 Protection Saddles

.1 On piping 50mm (2") and smaller, carry insulation over pipe hangers. Canvas jacket shall be neatly cut and formed to fit over hangers. On chilled and cold water piping, insert sections of insulation into space above pipe at each hanger. Seal saddle and pipe with insulation.

.2 On insulated steel pipe over 50mm (2") diam. use at each hanger or support, Grinnell Fig. 160, 161 or 162 to suit pipe size and insulation thickness. Pack space between saddle and pipe with insulation.

.3 On copper piping over 50mm (2") diam. use at each hanger or support Grinnell Fig. 167 protection shield or equal. Shields shall have minimum length of 300mm (12") to spread weight.

1.16 SUPPORTS, BASES, PITS

.1 Supply and erect all special structural Work required for installation of tanks, pumps, fans, motors and other apparatus.

.2 Concrete pads, concrete for floating bases, curbs and pits to be supplied under Division 3. Supply all anchor bolts, fasteners and foundation drawings. Unless noted otherwise, all major pieces of equipment such as pumps, compressors, fans, etc. to be mounted on 150mm (6") concrete pad. Refer to standard details for method of forming pump bases, etc.

.3 Mount equipment suspended above floor level but not detailed on platform bracketted from wall. Where wall thickness is inadequate to permit such brackets, carry supports to either ceiling or floor, or both as required.

1.17 FLASHING

.1 Where pipes or ducts go through a roof or wall, they should be boxed-in and flashed as per Division 3. Allow for expansion and contraction of pipe. Flashing shall be waterproof.

1.18 ACCESS DOORS

.1 Division 15 - Mechanical Contractor and his sub-trades to provide access doors where valves, dampers and/or any other mechanical equipment requiring access are built-in.

.2 In general terms, mechanical sub-trade responsible for supplying the valve, dampers etc. shall provide the access door required to get to the valve, damper etc.

- .3 Access door to be 2.5mm (12 ga.) steel, 300mm x 450mm (12" x 18"), finished prime coat only, with concealed hinges, anchor straps, plaster lock and without screws, all equal to Milcor manufacture. Where it is necessary for persons to enter through door, doors to be at least 450mm x 600mm (18" x 24").
- .4 In applied tile or exposed glaze or unglazed structural tile, access doors shall take the tile and be sized and located to suit tile patterns. In plaster ceilings, doors shall take the plaster. In masonry walls access doors to be sized and located to suit masonry unit sizes. In lay-in acoustic tile ceilings, no access doors are required, but install an approved coloured marking device in the ceiling tile below all points requiring access. Refer to Architectural Room Finish Schedule and details on architectural drawings.
- .5 Supply access doors for concealed valves or groups of valves, dampers, fire dampers, flush valves, shock arrestors, trap seal primers, etc.
- .6 Access doors located in fire rated ceilings and walls shall be an approved ULC stamped, fire rated door.

1.19 IDENTIFICATION OF EQUIPMENT

- .1 Provide manufacturer's nameplate on each piece of equipment.
- .2 In addition Mechanical Contractor shall provide equipment I.D. tag minimum size 87mm x 32mm x 2.3mm (3-1/2" x 1-1/2" x 3/32") nominal thickness laminated phenolic plastic with black face and white centre. Engraved 6mm (1/4") high lettering. For motors and controls and for larger equipment such as chillers, tanks, 25mm (1") high lettering; for hot equipment such as boilers and convertors, provide engraved brass or bronze plates with black paint filled identification.
- .3 Identify as follows: equipment type and number (e.g. pump no. 2), service or areas or zone building served (e.g. south zone chilled water primary).
- .4 Provide manufacturers' registration plates (e.g. pressure vessel, Underwriters' Laboratories and CSA approval plates) as required by respective agency and as specified.

1.20 FLOOR PLATES AND SLEEVES

- .1 Set sleeves in concrete forms for all pipes and ducts passing through concrete walls, beams and slabs.
 - .2 Pipe sleeves to extend above floor line as follows:
 - .1 Unfinished areas - 25mm (1")
 - .2 Finished areas (copper sleeves) - 6mm (1/4")
-

- .3 Mechanical rooms, kitchens and washrooms - 100mm (4")
- .4 Caulk sleeves to provide watertight installation.

- .3 Where pipes pass through floors and walls in finished areas and where exposed to view, provide Crane #10 B.C. chrome-plated pressed floor plates.
- .4 Install galv. oversize pipe sleeves on passing through walls or partitions, for building into wall construction, by other trades.
- .5 Sleeves and holes for cold water, chilled water and ice water lines to be large enough to accommodate pipe insulation. Insulation on hot water lines may stop at walls or floors.
- .6 Prior to installing sleeves in concrete beams, receive final jobsite approval by the Structural Contract Administrator .

1.21 MECHANICAL EQUIPMENT GUARDS

- .1 Meet safety requirements of Provincial Department of Labour and local authorities having jurisdiction.

1.22 V-BELT DRIVES

- .1 Fit reinforced belts in sheave grooves matched to drive.
 - .2 For 0.25 KW (1/3 hp) to 7.46 KW (10 hp) motors use standard adjustable pitch drive sheaves, having plus/minus 10% range. Use mid-position of range for specified rpm.
 - .3 For over 7.46 KW (10 hp) motors, use sheave with split tapered bushing and keyway having fixed pitch unless specifically required for item concerned. Refer to Section 15600 and 15800 for fan requirements relating to V-belt, vari-pitch drives. Provide sheave of correct size as approved by Contract Administrator to suit balancing.
 - .4 Use minimum drive rating of two times nameplate rating on motor. Keep overhung loads under manufacturer's requirements on all prime mover shafts.
 - .5 With belt drive, provide motor slide rail adjustment plates, allowing for 150mm (6") minimum centre line adjustment.
 - .6 Obtain approval to use cast iron or steel sheaves secured to shafts with removable keys.
-

1.23 SCREWS, BOLTS AND FASTENERS

- .1 Use standard commercial sizes and patterns with material and finish suitable for service.
- .2 Use heavy hex heads, semi-finished unless otherwise specified. Use non-ferrous material throughout for plumbing services. Use type 304 stainless steel for exterior areas.
- .3 Bolts used on fan equipment for access to motors, bearings, filters and the like shall be heavy-duty.
- .4 Bolts shall not project more than one diameter beyond nuts.
- .5 Washers
 - .1 Use plain-type washers on equipment, sheet metal and soft gaskets, lock-type washers where vibration occurs, and resilient washers with stainless steel.

1.24 SPECIAL TOOLS AND SPARE PARTS

- .1 Furnish The City with spare parts as follows:
 - .1 One set of pump seals, packing for each pump.
 - .2 One casing joint gasket for each size pump.
 - .3 One set gaskets for each plate type heat exchanger.
 - .4 One glass for each gauge glass installed.
 - .5 One set of v-belts for each piece of machinery.
 - .6 One set of filters for each filter bank installed. ie. one set for both pre-filter and high efficiency filters.
 - .7 One spare cartridge for each thermostatic mixing valve.
- .2 Identify spare parts containers as to contents and replacement parts number.
- .3 Provide one set of all specialized tools required to service equipment as recommended by manufacturers.

1.25 PUMPS-GENERAL

- .1 Provide coupling guards on all pumps.
 - .2 Submit certified pump curves with shop drawings. Pumps shall be selected such that head at design conditions does not exceed 85% of maximum possible head at design flow rate.
 - .3 Manufacturer to include for checking and aligning pumps prior to start-up. Following completion of piping all base mounted pumps shall be aligned by a qualified millwright using a dial gauge. Alignment using a straightedge is not acceptable as it does not provide sufficient accuracy. The millwright shall provide a report indicating the degree of misalignment prior to carrying out the Work and the final readings when the alignment Work has
-

been completed. Final payment will not be made until a satisfactory report has been submitted.

- .4 Piping adjacent to pump to be supported from structure so no weight is carried on pump casings. Use long sweep elbows at pump.
- .5 All pumps to have motor size large enough to not overload at runout condition. If this requires larger motor than specified, pay for larger motor starter, wiring and the like.
- .6 Mount on cast iron or heavy steel base, having drip lips and tapped drainage holes. Provide air cock on each pump.
- .7 Provide spool pieces on pump suction and discharge, connections for future fitting of vibration isolators if found necessary. Spool pieces to be 454mm (18") long for piping up to and including 50mm (2") and 605mm (24") long for piping 63mm (2 1/2") and above.
- .8 Pump bases to have neoprene-steel-neoprene vibration isolators of sizes recommended by manufacturer unless alternate type base specified elsewhere in specification. Refer to standard details for installation and forming of pump bases.
- .9 Provide mechanical seals on all pumps.

1.26 OPENINGS IN FIRE SEPARATIONS

- .1 Provide firestopping for all openings in fire separations for passage of pipes, ducts, etc. to maintain integrity of fire separations.
 - .2 Firestopping
 - .1 Firestopping to be Dow-Corning Fire Stop System.
 - .2 Material shall be Dow-Corning silicone elastomer Fire Stop penetration Seal and/or Dow-Corning liquid silicone elastomer Fire Stop Foam of density, width and depth to maintain assembly fire resistive rating.
 - .3 Components shall be ULC listed.
 - .3 Installation
 - .1 Prepare all surfaces so they are clean, dry, and frost free, as per manufacturer's published recommendations.
 - .2 Use Sealant around single pipes and/or ducts.
 - .3 Use Foam for multiple pipe installation.
 - .4 Follow manufacturer's published installation instructions precisely including field quality control after installation.
 - .5 Submit to Contract Administrator, suitable document signed by manufacturer's local representative, stating:
 - .1 Div. 15 Contractor received sufficient installation instruction from manufacturer's representative.
-

1.27 TRIAL USAGE

- .1 The City reserves right to use any piece of mechanical equipment, device or material installed under this Contract, for such reasonable lengths of time and at such times as Contract Administrator may require, to make complete and thorough test of same, before final completion and acceptance of any part of Contract. It is agreed and understood, that no claim for damage will be made for any injury or breakage to any part or parts of the above due to aforementioned tests, whether caused by weakness or inaccuracy of parts, or by defective materials or workmanship of any kind whatsoever. Supply all labour and equipment for such tests.

1.28 SAFETY DEVICE TESTING

- .1 Make complete inspection of all safety devices to ensure:
 - .1 That safety devices are complete and in accordance with specifications and manufacturer's recommendations.
 - .2 That the safety devices are connected and operating according to all local regulations.
- .2 Safety devices to be inspected shall include, but not be limited to:
 - .1 Pressure relief valves
 - .2 Freeze protection devices
 - .3 Fire dampers
- .3 On completion of inspections, supply to Contract Administrator letters and/or certificates for their record, confirming that inspections have been completed.

1.29 TEMPORARY USE OF EQUIPMENT

- .1 Permanent systems and/or equipment not to be used during construction period, without Contract Administrator 's written permission.
 - .2 Heating systems may be used for temporary heating within limitations specified under clause 'Temporary Heating'. Refer also to 'General Conditions'.
 - .3 Equipment used during construction period to be thoroughly cleaned and overhauled. Replace worn or damaged parts so equipment is in perfect condition, to entire satisfaction of Contract Administrator and The City.
 - .4 Provide proper care, attention and maintenance for equipment while it is being used. If, in opinion of Contract Administrator , sufficient care and maintenance is not being given to equipment and systems, Contract Administrator reserves right to forbid further use of said equipment and systems.
-

- .5 Temporary use of equipment shall in no way relieve Contractor of providing twelve month guarantee on all equipment so used this guarantee period to commence as of date of final acceptance of building by The City as interpreted by Contract Administrator .
- .6 All air filters shall have bi-monthly inspection. Filters shall be cleaned and/or replaced depending on filter type during period in which ventilation units are being used for temporary heat and/or commissioning of system. Contractor to be responsible for and pay all costs for air filter cleaning service. Filters to operate between pressure drops noted in filter manufacturer's catalogue.
- .7 Steam, condensate and hot water heating systems used for temporary heating shall have proper chemical treatment under supervision of chemical treatment manufacturer as per Section 15600.

1.30 RECORD DRAWINGS

- .1 Provide one set of Contract prints to form Record Drawings, marked clearly in red pencil with all changes and deviations from piping and ductwork, including all Contract Changes.
- .2 Update Record drawings on a regular basis to ensure they are accurate.
- .3 This information will be used by others to create Record Drawings on CAD.

1.31 INSTRUCTIONS TO THE CITY'S PERSONNEL

- .1 In addition to start-up supervision and instruction of The City's personnel required of individual equipment manufacturers and systems as noted, Contractor's construction supervisor to instruct The City's personnel in operation and maintenance of all equipment and systems to satisfaction of Contract Administrator .
 - .2
 - .1 All instructions to The City's personnel shall be video taped by the Contractor.
 - .2 This video will remain property of The City and will be used for the sole purpose of training and orientation of The City's maintenance staff.
 - .3 Instruction shall include visual materials such as drawings, diagrams, and printed handouts.
 - .4 Instructor(s) shall provide the necessary audio-visual equipment and other aids necessary to convey thorough understanding of system and/or equipment operation and maintenance.
 - .5 Provide The City with one copy of video taped session in VHS or DVD format. The City to decide, and confirm format.
-

- .3 Provide The City with four copies of manuals incorporating following:
 - .1 Service instructions - including lists of spare and replacement parts and names and addresses of suppliers.
 - .2 Maintenance & Operating instructions.
 - .3 Revised shop drawings.
- .4 Forward manuals to Contract Administrator for review. Final payment will not be made until all required manuals have been received.
- .5 Review instructions with The City's representative to ensure The City's representative has a thorough understanding of equipment and its operation.
- .6 Contractor shall submit to Contract Administrator , suitable document signed by The City's representative, stating:
 - .1 The City has received satisfactory instruction in operation and maintenance of all equipment and systems.
 - .2 Operation and maintenance manuals have been reviewed with The City.
 - .3 Specified spare parts. keys, removable handles and the like, have been turned over to The City.

1.32 TEMPORARY HEATING

- .1 Obtain written permission from Contract Administrator to use permanent heating system for temporary heat. Operate systems in strict accordance with equipment manufacturer and Contract Administrator 's recommendations.

1.33 PAINTING

- .1 Finish painting of mechanical equipment, piping and the like, to be performed by Section 09900.
 - .1 Co-operate with Section 09900 in identifying equipment and piping where required for colour coding, pipe stencilling and the like.

1.34 IDENTIFICATION OF PIPING

- .1 Division 15 shall provide mechanical pipe identification with exception that Section 09900 shall provide Primary Color painting for identification.
 - .2 Identify fluids in piping with Mystic markers showing name and service, including temperature and pressure where relevant, and with Mystic arrows to indicate flow direction.
-

- .3 Apply primary colours in exposed areas only on finished piping surfaces, including secondary colour bands, to indicate type and degree of hazard.
- .4 Use CGSB 24-GP-3a and CSA and B53 colour codings and identification systems, using CGSB 1-GP-12c colour coding system schedule.

| | | | |
|----|-----------------------|-----------------------|-------------------------|
| .1 | Primary | Secondary | Legend and |
| | <u>Classification</u> | <u>Classification</u> | <u>Direction Arrows</u> |
| | Yellow 505-101 | Orange 508-102 | Black 512-101 |
| | Green 503-107 | Purple 511-101 | White 513-101 |
| | Blue 202-101 | Black 512-101 | |
| | Red 505-102 | Yellow 505-101 | |
| | White 513-101 | | |

- .5 Location of Identification
 - .1 Locate markers and classifying colours on piping systems, so that they can be seen from floor or platform.
 - .2 Identify piping runs at least once in each mechanical room.
- .6 Legends and colour classifications: Submit to Contract Administrator for approval, where differing from following table, at least two weeks before ordering material.
- .7 Table: Pipe and valve identification. Note: Information in brackets under Pipe Marker Legend column is explanatory and need not be included as part of legend test.

| | | | | |
|-----|--|-----------------------------|---------------------------|-----------------------------|
| .11 | <u>PIPE MARKER LEGEND</u> | <u>VALVE TAG LEGEND</u> | <u>PRIMARY COLOUR</u> | <u>SECONDARY COLOUR</u> |
| | Natural gas | N.G. | Yellow | Orange |
| | Glycol heat recovery supply | G.H.R.S. | Purple | White |
| | Glycol heat recovery return | G.H.R.R. | Purple | White |
| | Dom hot water supply | D.H.W.S. | Green | None |
| | Dom hot water recirc | D.H.W.R. | Green | None |
| | Storm sewer | S.S. | Green | None |
| | San sewer | SAN.S | Green | None |
| | Comb san storm sewer | C.S.S.S. | Green | None |
| | Refrigerant suction (include refrigerant no.) | REF.S. (N.O.) | Yellow | Black |
| | Vent (plumbing) | V.P. | Green | None |

1.35 IDENTIFICATION OF DUCTWORK

- .1 Use black 50mm (2") high stencilled letters (e.g. "Cold", "Hot", "Return", "Sanitary Exhaust", "Kitchen Exhaust") with arrow indicating air flow direction.
- .2 Distance between markings 15m (50') maximum.

- .3 Identify ducts on each side of dividing walls or partitions and beside each access door.
- .4 Stencil only over final finish.
- .5 Prior to installation, review general application of identification with Contract Administrator .

1.36 CLEANING AND FLUSHING OF PIPING SYSTEMS

- .1 On completion, each piping system shall be flushed out before installation of equipment, fixtures, etc. in order to remove any foreign material in piping.
- .2 Flush with water, unless noted otherwise in individual mechanical sections of specifications.
- .3 All plumbing fixtures and all equipment shall be thoroughly cleaned and left in first class operating condition.

1.1 GENERAL

- .1 Following Appendix of Manufacturers lists manufacturers of equipment and materials acceptable to Contract Administrator , subject to individual clauses under the various sub-sections of Mechanical Work Specifications. See item 'Materials' under this section of specification.
- .2 Product noted in individual specification clauses is an item that meets specification in all respects regarding performance, quality of material and workmanship, and is acceptable to Contract Administrator without qualification. Equipment proposed from other manufacturers listed as 'Approved Manufacturers' and alternates shall meet same standards.
- .3 Contractor to submit within forty-eight hours of notification from Contract Administrator , one (1) copy of fully and properly completed Appendix of Manufacturers listing thereon names of manufacturers of products which shall be used to execute Work of Contract. If list is not submitted within 48 hours, Contractor must use product named in each individual clause.
- .4 Submit shop drawings for all items marked with asterisk(*).
- .5 Request for equals must be received in Contract Administrator 's office no later than seven (7) working days prior to close of sub-trade bid.

1.2 EQUIPMENT OR MATERIAL & APPROVED MANUFACTURERS

.1 ELECTRIC MOTORS

.1 G.E.; Siemens; Tamper; Reliance; Leland; Lincoln; U.S. Electric; Century; Baldor; WEG; Toshiba

.2 INSULATION

- .1 Pipe Insulation Manville; Owens Corning; Knauf; Pabco; Fibreglas
- .2 External Duct Insulation Manville; Fibreglas; Knauf
- .3 Lagging Adhesive/Coating Bakor; Childers; Fosters
- .4 Refrigerant piping Armstrong; Rubatex
- .5 PVC pipe jacket Sure-Fit

.3 PLUMBING

- .1 Drainage of Waste
 - .1 Cast iron soil pipe Bibby; St. Croix
-

| | | |
|-----|--|---|
| .2 | Valves (gate & globe)* | Crane; Toyo; Kitz |
| .3 | Valves (ball)* | Toyo; Kitz; Nibco |
| .4 | Check valves to 2" diam.* | |
| .1 | Horizontal piping | Crane; Toyo; Kitz |
| .5 | Hangers and Supports | Grinnell; Crane; Myatt |
| .6 | Drainage specialties* (floor drains, roof drains, cleanouts, chair carriers, etc.) | Ancon; Zurn; Smith |
| .7 | Dielectric unions | Watts; Victaulic |
| .8 | Shock absorbers* | Zurn; Ancon; Smith |
| .9 | Strainers* | Spirax-Sarco; Muessco; Toyo; Crane |
| .10 | Pressure gauges* | Ashcroft; Kunkle; Morrison; Winters; Marshalltown; Ametek; Terrice |
| .11 | Thermometers* | Ashcroft; Terrice; Taylor; Weiss; Marshalltown |
| .12 | Hose bibbs & compression stops* | Crane; Emco |
| .13 | Gas cocks* | Toyo; Neuman-Milliken |
| .14 | Gas regulators* | Fisher |
| .15 | Plumbing fixtures* | Crane; American-Standard; Kohler |
| .16 | Plumbing brass* | American Standard; Crane; Cambridge |
| .17 | Flush valves* | Crane; Teck; Sloan; Zurn |
| .18 | Stainless steel sinks* | American-Standard; K.I.L.; Briggs & Wessan; Kindred Industries; Architectural Metals Industries; Aristaline |
| .19 | Toilet seats* | Olsonite; Moldex; Centoco; Bemis |
| .20 | Sump pumps* | Monarch; Barnes; Armstrong; Gorman Rupp; Marlow |

| | | |
|-----|---|--|
| .21 | Gas-fired water storage heaters* | State; John Wood; A.O. Smith; Jet Glass; Rheem |
| .22 | Hot water recirc. pumps* | Armstrong; B & G; Grundfos |
| .23 | Drinking fountains* | Crane; American-Standard; Kohler |
| .24 | Backflow preventers* | Watts; Conbraco |
| .4 | LIQUID HEAT TRANSFER | |
| .1 | Gas-fired make-up unit* | Hastings; Engineered Air |
| .5 | AIR DISTRIBUTION | |
| .1 | Ducturns, damper hardware, fan connections* | Duro-Dyne |
| .2 | Duct Sealer | Duro-Dyne; 3M; Flexa-Duct; United; Bakelite |
| .3 | Fire Damper* | Controlled Air; Penn; Air Balance; C.A.A.; Hart & Cooley; Ruskin; Nailor; Cesco |
| .4 | Filters* | A.A.F.; Camfill-Farr; Cambridge; Continental; Airguard |
| .5 | Louvres* | Airolite; Carnes; Penn; Air-O Vent; Canadian Advanced Air; H & C; Westvent; Ventex |
| .6 | Ceiling exhaust fans* | Penn; Tradewind; Greenheck; Loren Cook |
| .7 | Range hoods* | Broan; Leigh; Trade Wind |
| .8 | Air cooled condensing units* | Carrier; McQuay; Keeprite; Engineered Air; York; Lennox |
| .9 | Diffusers, registers & grilles* | E.H. Price; Hart & Cooley; Titus; Carnes; Nailor |
| .10 | Acoustic duct insulation* | Manville; Fibreglas; Ultralite; Knauf |
| .11 | Variable volume air valves* | E.H. Price; Nailor; Titus; Hart & Cooley; Anemostat |
| .12 | Chimney B-Vent* | Metalbestos; ECCO; Belvent; Metal Fab |

- .13 Chimney A-Vent* Metalbestos; ECCO; Belvent;
Metal Fab
- .14 Positive pressure chimney* Metalbestos; Metal Fab;
Van Packer; Security; Ampco;
Cheminée Lining
- .15 Refrigerant piping and accessories* Henry; Mueller
- .16 Spiral ductwork* AMS; Basar; United;
Vent Air; Pellaers
- .17 Heat recovery units* Temp-X Changers; Z-Duct
- .18 Backdraft damper* Penn; Greenheck; Ventex
- .6 CONTROLS/INSTRUMENTATION
 - .1 Temperature control system* Honeywell; Johnson;
Siemens-Landis; Delta
- .7 H.V.A.C. BALANCE AND TESTING
 - .1 H.V.A.C. Balance & Testing Agency Airdronics Inc.; DFC; AHS;
Air Movement

1.1 GENERAL

- .1 All drawings and all sections of the specification shall apply to and form an integral part of this section.

1.2 WORK INCLUDED

- .1 Labour, material, plant, tools, equipment and services necessary and reasonably incidental to completion of external insulation for mechanical equipment, piping, ductwork.

PART 2 - PRODUCTS

2.1 MATERIALS

- .1 All materials shall be equivalent in all respects to specified products and shall be used only in applications intended by the manufacturer. Materials not specifically intended for the purpose shall not be used. Approved materials shall not be diluted or blended with other materials unless specifically recommended by the manufacturer of the approved material.
- .2 All final pipe and duct installations including insulation, covering and adhesive shall have a ULC Certified flame spread rating of not greater than 25, and a smoke developed classification of not more than 50.
- .3 All canvas shall be treated to be fire retardent in accordance with ULC standards.
- .4 Wire to be 1.2mm (18 ga.) stainless steel, dead soft annealed, type 304.

2.2 COLD INSULATION - PLUMBING

- .1 Material
 - .1 On pipes 50mm (2") diam. and under, use 12mm (1/2") Fiberglas 112 kg/m³ (7 lb./cu. ft.) density pipe insulation with ASJ jacket.
 - .2 On pipes 62mm (2-1/2") diam. and larger, use 25mm (1") Fibreglas 88 kg/m³ (5-1/2 lb./cu. ft.) density pipe insulation with ASJ jacket, c/w vapor barrier.
 - .3 Vent piping in cold attics shall be less vapor barrier jacket and wired on.
 - .2 Location
 - .1 All domestic cold water piping.
 - .2 All cooling coil condensate drains.
 - .3 Roof hoppers, vertical and horizontal storm drains except in crawlspaces.
-

- .4 Vent piping for a developed length of 3m (10'-0') from roof terminals.
- .5 Vent piping located in cold attics and in other cold locations.
- .6 Sump pump discharge lines that pass through ceiling spaces.
- .7 Water meters.
- .8 Run outs from mixing valves to shower heads.

2.3 HOT INSULATION - PLUMBING

- .1 Material
 - .1 Fibreglas insulation with all service jacket (ASJ) and self seal lagging adhesive.
 - .2 On pipes 50mm (2") diam. and under, use 25mm (1") Fibreglas 112 kg/m³ (7 lb./cu. ft.) density insulation.
 - .3 On pipes 62mm (2-1/2") diam. and larger, use 38mm (1-1/2") Fibreglas 88 kg/m³ (5-1/2 lb./cu. ft.) density insulation.
- .2 Location
 - .1 All domestic hot water, and tempered water supply and hot water recirculation piping.

2.4 WHITE PVC INSULATION COVER

- .1 Cover insulation and insulated fittings with white PVC fitting covers.
 - .2 The fitting cover system shall consist of one-piece pre-molded high impact PVC fitting covers with fiber glass inserts and accessories, including elbows, tee/valves, end caps, mechanical line couplings, specialty fittings, jacketing, tacks, and PVC tape.
 - .3 Cover shall have a flame spread rating of not more than 25 and a smoke developed classification of not more than 50.
 - .4 Cover shall be resistant to and not promote growth of fungi or bacteria.
 - .5 Cover shall be UV resistant for use indoors or outdoors. Paint outdoor fittings for further UV and colorfast protection.
 - .6 Locations
 - .1 All exposed piping in public areas and storage rooms.
-

2.5 BREECHING INSULATION

- .1 Insulate natural draft boiler and hot water heater breechings, including uptakes from equipment, with 50mm (2") thick Paroc 1200 premolded pipe insulation c/w all service jacket. Insulation to have a density of 192 kg/cu.m (12 lbs./cu. ft).

2.6 VAPOUR BARRIER RIGID INSULATION

- .1 Following ducts externally insulated with Fibreglas RFFRK reinforced foil-faced vapour seal duct insulation type FF 340 g. (4.5 lb./cu.ft.) density.
 - .1 25mm (1") Thickness
 - .1 All rectangular supply air ductwork, greater than 1200mm (48") wide, on discharge of fan systems with cooling coils.
 - .2 All rectangular supply air ductwork on discharge of fan , , , .
 - .2 50mm (2") Thickness
 - .1 All rectangular exhaust and relief ducts, supply and return air ducts from/to RTUs not shown acoustically lined from roof or wall back for a length of 1.8m (6'-0") or from wall or roof discharge back to damper, whichever is greater.
 - .2 All rectangular roof ducting to centrifugal exhaust fans located on roofs.
 - .3 All outside air ductwork.

2.7 REFRIGERANT PIPE INSULATION

- .1 Insulate following refrigerant piping lines with 12mm (1/2") Armstrong Armaflex AP sealed with Armstrong 520 adhesive. Refinish exposed and exterior insulation with Armstrong WB Armaflex finish.
 - .2 Cover outdoor insulation with aluminum jacket CSA HA Series-M1980.
 - .1 Crimped or embossed alloy jacketing 0.4mm thick with longitudinal slip joints and 50mm end laps with factory attached protective liner on interior surface. Aluminum alloy butt straps with mechanical fastener.
 - .2 Jackets on fittings, 0.4mm thick, die shaped components of alloy with factory attached protective liner on interior surface.
 - .3 Location
 - .1 All suction refrigerant piping.
 - .2 All hot gas piping outdoors.
 - .3 All liquid and hot gas refrigerant piping for length of 1.8m (72") before rising up through a roof or passing out through an exterior wall.
-

PART 3 - EXECUTION

3.1 WORKMANSHIP

- .1 Work shall be performed by licensed journeymen.
 - .2 Apply insulation materials, accessories and finishes in accordance with manufacturer's recommendations.
 - .3 Do not apply coverings until hydrostatic tests have been completed, surfaces are free of grease, scale, moisture, and heat tracing where required has been installed. Insulation shall be clean and dry when installed and during application of any finish.
 - .4 Apply insulation and coverings to equipment and piping which will operate with hot or warm liquid vapour, while surface is hot. Provide any required temporary heat to accomplish this.
 - .5 Cold surfaces to be dry and ferrous surfaces to be coated with rust penetrating protective paint before applying insulation and vapour barriers.
 - .6 Vapour barriers and insulation to be complete over full length of pipe or surface, without penetration for hangers, duct or seams, and without interruption at sleeves, pipe and fittings.
 - .7 Install insulation with smooth and even surfaces, with round shapes laid to true circular and concentric shape, shaped to blend with fitting insulation and adjacent covering; with full length section and tight to insulated object.
 - .8 Pack solid around all pipes where they pass through sleeves in walls, floor slabs, etc. for full thickness of floor with fibreglas or rockwool. Refer to firestopping clause where piping passes through fire separations. On all services, carry full insulation thickness through walls, floors, etc. Protect insulation of exposed pipes passing through floors with 1.2mm (18 ga.) galv. iron 150mm (6") from finished floor.
 - .9 On piping, gouge out insulation for proper fit where there is interference between weld bead and insulation. Bevel insulation away from studs and nuts to permit their removal without damage to insulation. Closely and neatly trim around extending parts of pipe saddles, supports, hangers and clamp guides. Seal with insulating cement.
 - .10 Use pipe covering protection saddles with roll type hangers unless otherwise indicated.
 - .11 Butt joints
 - .1 Place joints on top of duct wherever practical. Butt joints on side of duct for flexible duct insulation.
-

.2 Adhere and seal laps of vapour barrier cover or vapour barrier strip of 100mm (4") minimum width furnished with insulation, using vapour seal adhesives.

- .12 Sagging of duct insulation will not be acceptable.
- .13 Stagger both longitudinal and horizontal joints, on duct insulation of multilayered construction.
- .14 Duct insulation with vapour barrier shall be continuous, except at fire dampers.
- .15 Ducts acoustically lined need no external insulation, unless specifically noted otherwise.
- .16 Existing duct and pipe covering damaged or cut back during installation Work to be made good with same insulation as specified for new Work.
- .17 Protect insulation against elements during all stages of application.
- .18 Do not cover manufacturer's nameplates. Cut insulation on 45 deg. angle to nameplate edge and seal.
- .19 Covering to be uniform in diameter, smooth in finish. Place longitudinal seams so as to be invisible.

3.2 COLD INSULATION - PLUMBING

- .1 Fibreglass
 - .1 Insulate flanges, fittings and valve bodies, etc.
 - .2 Fasten longitudinal laps with staples and seal with Swifts Adhesive #3218.
 - .3 Butt joints wrapped with a 100mm (4") strip of ASJ. Stagger joints on multiple layers.
 - .4 Refinish exposed piping with canvas and coat with Bakor 120-18 white fire retardent lagging adhesive.
 - .5 All fittings shall be insulated by wrapping with 25mm (1") thick layers of 340 g. (3/4 lb.) density flexible fibreglass attached with jute twine. Surface shall be wrapped with Friction Tape and sealed with and asphaltic sealing compound. Over this to be applied a smooth coating of insulating cement. Recover fittings with ASJ vapour seal jacket and brush coat with fire retardent white lagging adhesive.

3.3 HOT INSULATION - PLUMBING

- .1 Application as per Clause "Cold Insulation - Plumbing".
 - .2 Insulate flanges, fittings and valve bodies, etc.
-

- .3 Fasten longitudinal laps with staples and seal with Swifts Adhesive #4518.
- .4 Butt joints wrapped with a 100mm (4") strip of ASJ. Stagger joints on multiple layers.
- .5 On exposed piping refinish with canvas and coat with Bakor 120-18 white fire retardent lagging adhesive.
- .6 All fittings shall be insulated by wrapping with 25mm (1") thick layers of 340 g. (3/4 lb.) density flexible fibreglass attached with jute twine. Surface shall be wrapped with Friction Tape and sealed with and asphaltic sealing compound. Recover fittings with ASJ jacket pasted directly over the smooth coat of insulating cement. Finish with brush coat of Bakor 120-18.

3.4 INSULATION CLADDING

- .1 For aluminum jacketting installation, install in strict accordance with manufacturer's published recommendations.

3.5 WHITE PVC INSULATION COVER

- .1 Preparation
 - .1 Proto Fitting Covers shall be applied on clean, dry surfaces.
- .2 Application
 - .1 General
 - .1 The matching fiber glass insert shall either be wrapped completely around the fitting or snugly positioned inside the Proto Fitting cover for proper fit. The insert shall cover the full inner surface area of the Proto Fitting Cover. The Proto Fitting Cover shall then be applied over the fitting and insert, and the throat secured by either tack fastening, taping, sealing with a solvent type PVC adhesive, or banding.
 - .2 Cold Pipe
 - .1 Fitting systems below ambient temperature must have a continuous vapor retarder, either with Proto PVC Tape, Proto Butt Strips, Proto PVC Adhesive, or a vapor retarder mastic as specified by the Contract Administrator . When using Proto PVC Tape, a 2" (51mm) minimum downward overlap is recommended for optimum performance. Care should be taken not to stretch the last 2" (51mm) of Proto PVC Tape, to avoid stretching or creeping.
 - .3 Hot Pipe
 - .1 Insulate as per General Instructions given above. Due to PVC softening point at approximately 150 deg. F (70.6 deg. C), care should be taken to ensure sufficient insulation thicknesses are applied. For hot piping which requires Knauf Pipe insulation over 1-1/2" (38mm) wall

thickness, an extra fiber glass insert shall be applied for each additional inch of pipe insulation wall thickness. Knauf recommends the surface temperature of the pipe insulation and PVC to be no higher than 125 deg. F (52 deg. C). To complete application of Proto PVC Fittings on hot piping, the throat seam shall be riveted or tacked.

3.6 BREECHING INSULATION

- .1 Insulate all fittings, etc. with sections of same material as specified for breeching.
- .2 Fasten longitudinal laps with staples and seal with Swifts Adhesive #3218.
- .3 Butt joints wrapped with a 100mm (4") strip of ASJ. Stagger joints on multiple layers.
- .4 Recover breeching insulation with 170 g. (6 oz.) canvas adhered with Bakor 120-18 white fire retardent lagging adhesive. Finish with brush coat of same adhesive.
- .5 Paint portions of uninsulated breeching steel and supports with two coats of high temp. black enamel.
- .6 Install insulation to allow for breeching expansion.

3.7 VAPOR BARRIER RIGID DUCT INSULATION

- .1 Insulation applied with edges tightly butted and secured by impaling on pins welded to duct. Pins to be staggered, minimum 300mm (12") o.c. in every direction. This applies to all sides. Secure insulation to pins with metal fasteners. Pins shall be long enough to bend after fasteners have been applied. Install two fasteners to all insulation on roof. Dab adhesive over pins and fasteners.
 - .2 Seal all joints, edges and breaks in vapor seal jacket with vapor barrier foil of the same quality as that of duct membrane 100mm (4") wide with BF 85-15 lagging adhesive.
 - .3 Wrap exposed ducts with fire retardent paper recovered with 170 g. (6 oz.) canvas secured with Bakor 120-18 white fire retardent lagging. Brush coat with same adhesive. Do not use staples.
-

3.8 REFRIGERANT PIPE INSULATION

- .1 Insulate fittings, valve bodies, etc.
- .2 All fittings shall be insulated with mitre-cut pieces of Armaflex AP pipe insulation the same size as on adjacent piping.
- .3 Seal joints and seams with adhesive, and refinish exposed fittings with specified finish. Refinish all exposed piping with two additional coats.
- .4 Where insulation comes in close contact with adjacent equipment or piping having surface temperatures above 100 deg. C, provide additional protection to ensure against deterioration of insulation by heat.
- .5 Allow adhesive joints of Pipe insulation to dry 24 hours to 36 hours before applying finish. Apply finish directly to clean, dry insulation in two coats. Wipe surface with cloth dampened with non-oily solvent such as alcohol or toluol to clean surface and remove powdered lubricant. Allow first coat to dry minimum of two hours before applying second coat. Before applying finish, read precautionary information on can label.
- .6
 - .1 Finish insulation located outdoor with Armstrong WB black Armaflex finish. Do not apply over joints freshly cemented with 520 adhesive. Allow adhesive joints of Armaflex pipe insulation to dry 24 hours to 36 hours before applying finish. Apply finish directly to clean, dry Armaflex insulation in two coats. Wipe surface with cloth dampened with non-oily solvent such as alcohol or toluol to clean surface and remove powdered lubricant. Allow first coat to dry minimum of two hours before applying second coat. Before applying Armaflex WB finish, read precautionary information on can label.
- .7 For aluminum jacketting installation install in strict accordance with manufacturer's published recommendations. Make weathertight application.

1.1 GENERAL

- .1 All drawings and all sections of the specifications shall apply to and form an integral part of this section.

1.2 WORK INCLUDED

- .1 Provide labour, material, equipment and services necessary for and incidental to the supply and installation of the systems shown on the drawings and hereinafter specified.
- .2 Generally this shall include:
 - .1 Sanitary Drainage System
 - .2 Storm Drainage System
 - .3 Cold and Hot Water Supply System
 - .4 Natural Gas Piping System
 - .5 Plumbing Fixtures and Equipment

1.3 RELATED WORK SPECIFIED ELSEWHERE

- .1 Section 15010 Mechanical General Provisions
- .2 Section 15051 Acceptable Materials & Equipment
- .3 Section 15180 Insulation
- .4 Section 15300 Site Services
- .5 Section 15600 Liquid Heat Transfer
- .6 Section 15800 Air Distribution
- .7 Section 15900 Controls/Instrumentation
- .8 Section 16010 Electrical General Provisions

PART 2 - PRODUCTS

2.1 PIPE AND FITTINGS

- .1 General
 - .1 Pipe and fittings shall conform to the standards listed in the applicable Building Code (latest revision).
 - .1 Flanged joints must have suitable gasket and bolts.
 - .2 Use brass nipples between copper piping and flush valves or c.p. brass goods.
 - .3 Where alternate piping materials or jointing are specified a uniform type of pipe and fittings shall be used throughout each system.
-

- .2 Drains and vents - storm and sanitary
 - .1 Drains and vent pipes shall be in accordance with local or provincial regulations with the following exceptions, unless otherwise specified.
 - .2 All cast iron soil pipe shall be class 4000.
 - .3 Cast iron soil pipe may be hub and spigot or mechanical joint. Mechanical joint couplings shall have a corrugated stainless steel sleeve over the joint with stainless steel worm drive securing bands tack welded to the sleeve. Titan or approved equal.
 - .4 Polyvinyl chloride (PVC-DWV) pipe and fittings shall be solvent cement socket weld joint certified to ULC Standard CAN/OLC-S102.2.
 - .5 No plastic, asbestos cement or aluminum pipe accepted unless specifically called by the Contract Administrator.
- .3 Water Piping - Domestic Cold, Hot, Hot Water Recirculating,
 - .1 Pipe - Type 'L' third party certified hard copper tube to ASTM B.88. Fittings - Wrought copper or cast brass, solder joint pressure fitting. Flanges - Cast brass 1034 kPa (150 lb.) ANSI B16.24.
- .4 Sewage and Sump Pump Discharge
 - .1 Up to 50mm (2") Diam: Pipe - DWV copper. Fittings - DWV solder joint pipe.
 - .2 64mm (2-1/2") and larger: Pipe - Schedule 40 galvanized steel victaulic roll grooved. Fittings - Victaulic malleable with Victaulic style 07 Zero-flex rigid couplings, flush seal grade '0' gasket.
- .5 Natural Gas Systems
 - .1 Pipe
 - .1 Up to 150mm (6"): - Schedule 40 carbon steel, continuous weld or electric resistance weld pipe conforming to ASTM A53 Grade B.
 - .2 Fittings
 - .1 Up to 50mm (2"):
 - .1 Screwed fittings - 1034 kPa (150 psi) black malleable iron, banded.
 - .2 Socket weld fittings - 13,800 kPa (2000 psi) forged steel.
 - .3 Unions - 1034 kPa (150 psi) brass to iron seat.
 - .2 64mm (2-1/2") and larger:
 - .1 Butt welding fittings to be Crane manufactured to ASTM A234. Flanges to be Grinnell forged carbon slip-on welding flanges conforming to ASTM A181, Grade 1. Gaskets to be Cranite pre-formed asbestos. Site or shop cut gaskets unacceptable. Use ring gaskets on raised face flanges and full faced gaskets on flat faced flanges. Use 1034 kPa (150 psi) flanges on systems to 689 kPa (100 psi). Thread-O-Lets and Weld-O-Lets to be manufactured to ASTM A181, Grade 1.

2.2 WALL SLEEVE SEALS

- .1 Where water and sanitary service lines are sleeved through concrete wall, provide schedule 40 steel pipe sleeves and LINK-SEAL sleeve seals.

2.3 VALVES

.1 General

.1 Valve parts must be of material recommended by mfg. for service specified. Valves must be installed with stems upright or horizontal, not inverted. Valves not specifically covered herein shall be of comparable quality to those specified.

.2 Water

.1 Domestic cold, hot, hot recirculating:

.1 All valves up to 19mm (3/4") ball valves (Appollo, Conbraco).

.2 Gate valves up to 50mm (2"): Crane 1334, Newman Hattersley T609, Kitz 43, Nibco S-134.

.3 Globe valves up to 50mm (2") - Toyo 221, Crane 1310, Newman Hattersley Fig. 13, Kitz 10, Nibco S-235Y.

.4 Swing check valves up to 50mm (2"): Toyo 237, Crane 1342, Newman Hattersley A61, Nibco S413B.

.5 Spring loaded check valves up to 50mm (2"): MAS-700.

.6 Ball balancing valves with balancing plate up to 50mm (2"): Toyo Fig. 5049A, Newman Hattersley 1979, Kitz 59, Crane 9322, Nibco S-585-70.

.7 Ball valves up to 50mm (2"): Toyo Fig. 5049A, Newman Hattersley 1979, Kitz 59, Crane 9322, Nibco S-585-70.

.2 Sump and sewage pump discharge:

.1 Gate valves up to 50mm (2"): Crane 1334, Newman Hattersley T609, Kitz 43, Nibco S134.

.2 Gate valves 64mm (2-1/2"): Crane 465-1/2, Newman Hattersley 504, Nibco F-617-0.

.3 Check valves up to 50mm (2"): Crane 1342, Toyo 237, Newman Hattersley A61, Nibco S413B.

.3 Drain valves up to and including 19mm (3/4"): Toyo Fig. 5046 ball valve with garden hose threaded outlet c/w chain and cap.

.4 Drain valves 25mm (1") and larger: Gate valves as specified above, with discharge piped to suitable drain.

.5 Hose bibbs inside building: Crane Model 5046 nickel plated brass wall faucet with Watts chrome plated vacuum breaker hose end.

.3 Natural Gas

.1 Valves up to 50mm (2") size - Toyo 5044A and Kitz Code No. 58 ball valve or Newman Hattersley 1969F. Newman-Milliken 200M, lubricated screwed plug valve.

.2 Valves 64mm (2-1/2") and larger: Newman-Milliken 201M flanged plug valve. Newman-Milliken 200M, lubricated screwed plug valve.

2.4 STRAINERS

.1 Water Systems:

- .1 Up to 50mm (2") size - screwed bronze body Y pattern, with stainless steel perforated screen Newman Hattersley 807, Spirax Sarco Type BT.
- .2 64mm (2-1/2") and larger - Spirax Sarco Type 733-125, flanged cast iron body basket type screen with bolted cover and drain plug, perforated stainless steel screen, w.p. 860 kPa (125 psig).
- .3 Perforation Sizes: On pump suction - 3mm (1/8"). All other - 1.5mm (1/16")

2.5 EXPANSION JOINTS

.1 Copper Pipe sizes 75mm (3") and under:

.1 FLEXONICS Model HB bronze expansion compensators designed for the pressure to be external to the 2-ply bronze bellows for positive squirm elimination, and complete with anti-torque device, limit stops, internal guides with female streamline ends. All brazed joints to be by heliarc process.

.2 Steel Pipe sizes over 75mm (3") and under:

.1 FLEXONICS Model H expansion compensators designed for the pressure to be external to the 2-ply stainless steel bellows for positive squirm elimination, and complete with anti-torque device, limit stops, internal guides with female streamline ends.

.3 Anchors and guides in contact with copper pipe shall be copper, or copper-plated.

.4 Guides shall be FLEXONICS pipe alignment guides.

2.6 THERMOMETERS

.1 Ashcroft Series EI, bi-metal dial thermometers, having stainless steel cases and rings with bronze or stainless steel stems and brass separable threaded wells. Temperature range 0 deg. to 100 deg.C (32 deg. to 212 deg.F) unless otherwise noted. Accuracy to 1% of full span.

.2 Thermometers located up to 1.5m (5'-0") above finished floor to have 75mm (3") diam. dials; and located above 1.5m (5'-0"), 125mm (5") diam. dials. Use back or bottom inlet stems, whichever is best suited for ease of reading. Choice of stem types shall not be made until piping and equipment, etc. has been installed. Stem type to be approved by Contract Administrator.

.3 Separable wells to have insulation extensions, where mounted on insulated piping or equipment, to ensure dials are clear. Stems and wells to be immersed in liquid flow, minimum length of stems to be 150mm (6").

- .4 Where separable well is mounted in pipe 38mm (1-1/2") diam. or less, enlarge pipe to 50mm (2") diam. for well length plus 75mm (3").

2.7 PRESSURE GAUGES

- .1 Ashcroft type 1010 quality pressure gauges having bronze geared movements, bronze bourdon type, friction glass cover, steel slip ring, and precision type pointer. Accuracy to be 1% of full span.
- .2 Use 113mm (4-1/2") dials. Where mounted above 3m (10') from floor level, use 150mm (6") dial. Gauges chosen with indicating needle at 12 o'clock position for normal operating pressure. Gauges shall have dual indication (i.e. kPa, psi) with kPa prominent figure.
- .3 Gauges to have Ashcroft Fig. DH-11 brass needle valve. Provide Ashcroft Fig. 1/4-1106B pulsation dampeners on pump gauges.
- .4 Gauges, subject to vibration, to have copper tube extensions to locate away from source of vibration.

2.8 TRAP PRIMERS

- .1 Provide approved Zurn trap primers where noted on plans and/or as required by Plumbing Code, to maintain trap seals.

2.9 SHOCK ABSORBERS

- .1 Where shock absorbers are called for on water lines shall be Zurn Shoktrol sized in accordance with Plumbing and Drainage Institute standards.

2.10 CLEANOUTS

- .1 Cleanouts in cast iron soil pipe shall consist of cast iron ferrule with brass plug having raised head.
 - .2 Cleanouts in copper drainage: Brass screwed plugs with raised head.
 - .3 Cleanouts in cast iron screwed drainage fittings, (galvanized waste lines) shall consist of nipple and cap. Iron plugs not accepted. Exposed c.o. caps shall be chrome plated.
-

2.11 CLEANOUT ACCESS COVERS

- .1 Heavy traffic unfinished areas:
 - .1 Zurn Z-1425-24 heavy duty cast iron cover and frame, with securing screws.
- .2 Finished and unfinished areas:
 - .1 Zurn ZANB-1460-13 175mm (7") diam. polished nickel bronze frame and cover.
 - .2 Select cleanout access covers in areas having floor finish such as sheet vinyl tile, terrazzo, or carpet, to suit the finish. Cooperate with appropriate trades to apply finish to cleanout covers so they will be flush with floor, inconspicuous, and accessible. Floor cleanouts for sheet vinyl flooring shall be clamping type, Zurn ZXN-211R6-ST style, to properly seal (SVF) sheet vinyl flooring to cover. Refer to architectural room finish schedules for locations.
 - .3 On special floor, rough-in properly to conform to adjacent flooring material as per manufacturer's installation instructions.
- .3 Cleanouts in walls to be located adjacent to access door, or to have a suitable finished access cover flush with wall so as to present a neat finished appearance and leave cleanout easily accessible.

2.12 PLUMBING FIXTURES AND EQUIPMENT

- .1 General
 - .1 Supply, install and connect up, complete, all plumbing fixtures shown on mechanical and architectural drawings. Be responsible for protection of all fixtures until building is accepted by The City.
 - .2 All fixtures including trim shall be CSA approved, free from flaws or blemishes to approval of Contract Administrator. All finished surfaces shall be clear, smooth and bright, and guaranteed not to craze, discolour or scale. All fixtures shall be completely installed and connected to drain, vent, hot and cold water supply piping in approved manner.
 - .3 All visible parts of trimmings of all fixtures, including faucets, shower heads, piping, escutcheons, wastes, strainers, traps, tail pieces, supplies, stops, etc. shall be heavily chrome-plated. This shall also apply to Work at all NIC equipment and fixtures in finished areas.
 - .4 Except where specifically noted otherwise, supply and install screwdriver stop valve on hot and cold water supply to every fixture on project, in addition to valve or faucets on fixture itself.
 - .5 Provide adequate supports for all fixtures. Have these built into walls with back-up plates where required.
 - .6 Provide traps, and stops on supplies, for all fixtures and equipment.
-

-
- .7 Provide domestic water, vent and waste connections to all equipment requiring plumbing services. This shall include NIC items shown on architectural and mechanical drawings.
- .8 Provide shut-off valve on water supply connections at each piece of equipment.
- .9 Contractor shall confirm mounting heights for all fixtures before roughing in water, waste and vent piping.**
- .10 Heating/Air-Conditioning Equipment:
- .1 Connect water and drain to all heating and air-conditioning systems and equipment wherever noted in the specifications or on the drawings.
- .11 Miscellaneous Equipment:
- .1 Rough-in and connect services as required to all items of equipment requiring same.
- .12 Silicone Sealing of Fixtures:
- .1 Silicone seal perimeter edges of fixtures as specified herein.
- .2 Silicone to be mildew-resistant, translucent white silicone, General Electric Sanitary Silicone Sealant #SCS 1752.
- .3 Section 15400 shall provide silicone sealing of following fixtures: china drinking fountains, urinals, water closets, sinks (all types), and lavatories (china and enamelled steel).
- .4 Application of sealant shall be by experienced applicators, regularly employed for sealant application.
- .5 Properly adjust and align fixtures prior to sealant application.
- .6 Sealant bead to be smooth and neat, with proper proportions. Apply sealant in strict accordance with manf. published data.
- .7 For wall hung fixtures, seal only 3 edges; top and both sides, not bottom.
- .8 For china and enamel steel lavatories, seal perimeter edge between countertop and lavatory.
- .9 Do not apply silicone sealant onto stainless steel fixtures, unless noted otherwise.
- .10 Unless noted otherwise, silicone sealing of tubs, shower stalls and shower bases to be responsibility of architectural division, under direction of Contractor.
- .2 Fixtures
- .1 W.C. #1:
- .1 Crane 3814 Hymont Jr., vitreous china, floor mounted, elongated rim, insulated tank with bolt down lid, bolt caps, 6 litres per flush. 410mm (16")high.
- .2 Olsonite 10 CC open front seat less cover, self-sustaining concealed check hinge, colour white, stainless steel hinge posts, washers and nuts.
- .3 Speedway chrome plated flexible closet supply with screwdriver angle stop, inlet extension tube, chrome plated escutcheon plate.
-

-
- .2 W.C. #2: (Handicap)
 - .1 Crane 3814 Hymont Jr. Plus, vitreous china, floor mounted, elongated rim, insulated tank with bolt down lid, bolt caps, 6 litres per flush, 410mm (16") high.
 - .2 Olsonite 46 SSTL open front seat with cover, colour white, self-sustaining hinge, stainless steel hinge posts, washers and nuts.
 - .3 Speedway chrome plated flexible closet supply with screwdriver angle stop, inlet extension tube chrome plated escutcheon plate.
 - .3 Urinal #1:
 - .1 Crane 7179 Cromwell, vitreous china, washout, wall hung, stainless steel strainer, top spud 1" connection.
 - .2 Delta Commercial 81T291 flush valve, oscillating handle, screwdriver angle stop, vacuum breaker flush connection, coupling nut, wall and spud flanges.
 - .3 Zurn Z-1222 concealed fixture carrier with block feet.
 - .4 Lav. #1:
 - .1 Aristaline 0V1719 Stainless steel vanity basin, self rimming, integral overflow, 4" (100mm) centres.
 - .2 Cambridge Brass 86T110 metering faucet, v.p. aerator, mixing tee and inlet check tails, 86T151 coverplate, centre hole.
 - .3 Cambridge Brass offset 33T290 chrome plated cast brass p.o. plug with open grid strainer.
 - .4 Cambridge Brass 33T311 chrome plated, cast brass, adjustable 'P' trap with c.o. plug.
 - .5 Speedway flexible lav. supplies with inlet extension tubes and screwdriver angle stops.
 - .6 Truebro Lav Guard undersink protective drain & angle valve supply covers.
 - .5 Sink #1:
 - .1 Fiat MSB2424 (600mm x 600mm) molded stone mop service basin, integral drain, combination dome strainer and lint basket.
 - .2 Cambridge 28T2486, 8" (200mm) wall mounted faucet, bottom brace, 10-1/2" (263mm) spout with vacuum breaker, garden hose end, vandal proof 3" blade handles with sanitary hood, integral stops.
 - .3 Silicone seal sides of basin against walls.
 - .4 Fiat #832-AA hose and hose bracket, 30" (750mm) long flexible heavy duty rubber hose with brass hose coupling one end, Type 302 stainless steel hose bracket with rubber gripper.
 - .5 Fiat #889CC mop hanger.
 - .6 Sink #2:
 - .1 Kindred QSL2020/7 single compartment stainless steel with ledge, self-rimming, 16" x 18" x 7" deep I.D. (400mm x 450mm x 175mm) 3 hole drilling 8" (200mm) centres, 3-1/2" (90mm) basket strainer and tailpiece assembly, baked-on undercoating, under deck clamps.
 - .2 Delta commercial 100-WFELHHDF single lever 8" (200mm) centreset, swing spout, v.p. aerator cover plate, lever handle, S.S. ball.
-

- .3 Cast brass 'P' trap with c.o. plug.
- .4 Speedway chrome plated flexible supplies with screwdriver angle stops, chrome plated inlet extension tubes, chrome plated escutcheon plates.
- .7 Sink #3:
 - .1 Aristaline LBT6410P-1 3 compartment with ledge, stainless steel sink, self-rimming, 20" X 46 X 10" deep I.D. (520mm x 1180mm x 250mm), 3 hole drilling 8" (200mm) centres, 3-1/2" (90mm) basket strainer and tailpiece assembly, baked-on undercoating under deck clamps.
 - .2 Cambridge Brass 26T2524, 8" (200mm) centreset, 14" (350mm) tubular swing spout, v.p. aerator, 4" (100mm) Blade handles.
 - .3 Cast brass 'P' trap with c.o. plug.
 - .4 Speedway chrome plated flexible supplies with screwdriver angle stops, inlet extension tubes, chrome plated escutcheon plates.
- .8 D.F. #1: (Barrier Free)
 - .1 Elkay EDFP214C - wall mounted unit, all stainless steel enclosure, stainless steel receptor, self closing touch control, push bar on front, automatic stream height regulator, CSA approved, vandalproof screws. Flexi-guard safety bubbler. No lead design.
 - .2 c.p. brass adjustable 'P' trap Cambridge Brass 33T301.
 - .3 Speedway - c.p. flexible supply with screwdriver stop, inlet extension tube and escutcheon plate.
- .3 Equipment
 - .1 Floor Drains
 - .1 FD #1:
 - .1 Zurn ZXN-415-A cast iron floor drain with 6" (150mm) diam. adjustable 1/2" (13mm) thick nickel bronze strainer.
 - .2 FD #2:
 - .1 Zurn Z-415-R cast iron, adjustable nickel bronze strainer, cast iron collar, floor level clamping ring, vandalproof screws. Rough-in to adjacent flooring material as per manf. installation recommendations.
 - .2 Use in areas where sheet vinyl, sheet rubber, or sheet metal flooring material is used.
 - .3 FFD #1:
 - .1 Zurn Z-415-F cast iron floor drain, 3" x 9" (75mm x 225mm) polished nickel bronze strainer with one piece oval funnel with full port opening.
 - .2 Hot Water Circulating Pump P-2
 - .1 Pump shall be S.A. Armstrong in-line circulator with bronze body, bronze impeller, stainless steel shaft, mechanical seal, for working temp. of 107 deg.C, (225 F) working pressure of 862 kPa (125 psi).
 - .3 Sump Pumps P-1 and P-7 (Submersible) Grundfos "The Boss" Sump Pump
 - .1 Supply and install single submersible sump pump with built-in level controller c/w 10'-0" (3m) electrical cord, 1/3 HP, 115 V, 710 W, 6.3 A.

- .2 Div. 5 to provide 6mm (1/4") steel sump pit cover c/w angle iron frame and concrete anchors. Cover to have necessary openings for pump discharge, power and alarm cables, etc.
- .3 Provide Monarch Ltd. "PILARM" c/w mercury float switch with 10'-0" (3m) electrical cord, high level alarm. Wiring of float switch by Div. 16.
- .4 Domestic Water Heater (Electric)
 - .1 Professional Residential Electric Water Heater RHEEM PRO410T 38.5 imperial gallons, 208V, 2250 watts.
 - .2 Provide temperature and pressure relief valve, pipe local to nearest floor drain.
 - .3 All wiring by Div. 16.
- .5 Rink flooding angle valve.
 - .1 Lynxar products, 1 1/2" brass body F X M w/hydrolator, ULC/UL angle valve.
 - .2 Lexan 709006 1 1/2" red cap and chain.

2.13 BACKFILL MATERIAL

- .1 Bedding and backfill material to 300mm (12") above the pipe shall conform to standard WCA 3 for granular fill.
 - .1 Passing 3/4" 100%
 - .2 No. 4 80-90%
 - .3 No. 50 5-30%
 - .4 No. 200 0-5%
- .2 Granular backfill material other than as described in .1 above shall conform to standard WCA 2.
 - .1 Passing 3" 100%
 - .2 No. 4 40-80%
 - .3 No. 200 5-20%

PART 3 - EXECUTION

3.1 GENERAL INSTALLATION

- .1 Copper pipe shall not be buried except where specifically noted on drawings.
 - .2 All pipe shall be cut accurately to measurements taken at site, installed without springing or forcing. All changes in direction made with fittings.
 - .3 All connections to equipment made with unions or flanges.
 - .4 Remove valve working parts during installation to prevent damage from heat where brazing, soldering, or welding is used.
 - .5 Comply with latest CSA Standard W117.2 "Code for Safety in Welding and Cutting".
-

- .6 Drain pipes dropping into slab on grade shall have sisson joint arranged to take up movement of slab.
- .7 Run all piping in accessible pipe spaces in such a way that it does not interfere with free access into pipe space.
- .8 Co-operate with all sub-trades to properly locate all equipment connections.
- .9 Provide a shutoff valve on supply connections at each piece of equipment.

3.2 DRAINAGE SYSTEMS

- .1 Sanitary Drains
 - .1 Provide complete systems of sanitary drainage and venting to serve all fixtures and equipment. This includes local drains from equipment in Contract such as fan units, pump bases, etc.
 - .2 Run building sanitary drain from connection point outside building as noted on drawings.
 - .3 All drainage piping to W.C.'s shall be 100mm (4") dia. min.
 - .4 Provide trap primers where noted on drawings. Connect to trap in an approved manner.
 - .5 Cleanouts:
 - .1 Install cleanouts at all changes of direction, at intervals of not over 15m (50') in horizontal runs, at all points where obstructions might be formed and at points required by plumbing regulations or shown on drawings.
 - .2 Cleanouts shall be accessible. Cleanouts above furred ceilings or in concrete slabs on grade shall be extended to floor level with cleanout access cover and frame.
 - .3 Cleanouts on sink waste and vent pipes shall have a chrome-plated cap installed tight to wall. Cleanouts behind walls shall have access panel. Cooperate in locating cleanouts adjacent to access panels, etc. All cleanout plugs lubricated/sealed with mixture of graphite and linseed oil or Teflon tape. Check all cleanouts immediately prior to turning the job over to The City. Remove plugs, re-lubricate with graphite and oil, and re-install using only enough force to insure permanent joint, depending on location.
 - .6 Flash vents through roof in approved manner. Drains in floors shall be flashed or clamped to membrane water-proofing where required.
 - .2 Acid Drains
 - .1 General - provide acid drains where noted on plans to serve acid resisting floor drains, sinks, etc.
-

3.3 WATER SUPPLY SYSTEM

.1 General

- .1 Provide complete system of water supply piping to serve all fixtures, equipment, etc. This shall include cold water, hot water and hot water recirc. piping. Tempered water piping shall be considered to be hot water piping if water temp. is above 29 deg.C (85 deg.F).
- .2 Provide water meter to approval of Municipal Engineer.
- .3 Grade horizontal runs of piping to drain through risers.
- .4 Install drain valves with hose thread outlet at water meter, hot water tanks and in mains where shown and/or necessary for complete drainage.
- .5 Install shut off valves at water meter, hot water tanks and heaters, at all connections to major pieces of equipment, in all branches to fixtures or groups of fixtures.
- .6 Install dielectric insulating unions between all pipes or apparatus constructed of dis-similar metals. Use brass nipples at flush valves, etc.
- .7 Connect ends of all hot water risers to recirculation main and continue this main back through recirculating pump. Recirculating piping shall be so arranged as to provide continuous and positive circulation of hot water throughout system at all times.
- .8 Each recirculating branch shall have balancing valve.

.2 Water Pipe Sizes to Fixtures

| | <u>Cold</u> | <u>Hot</u> |
|--------------------|-------------|-------------|
| Lavatory basins | 13mm (1/2") | 13mm (1/2") |
| Flush valves | 25mm (1") | |
| Flush tanks | 13mm (1/2") | |
| Sinks | 13mm (1/2") | 13mm (1/2") |
| Hose bibbs | 19mm (3/4") | 19mm (3/4") |
| Drinking fountains | 13mm (1/2") | |
| Showers | 13mm (1/2") | 13mm (1/2") |

.3 Shock Absorbers

- .1 Supply and install shock absorbers on hot and cold water lines at each group of fixtures, each isolated fixture, and where noted on drawings. Sizes shall be as noted or in accordance with Plumbing and Drainage Institute Standard WH-201.
- .2 Where piping is concealed and not accessible provide air chambers one size larger than supply and 600mm (24") high.
- .3 Provide shock absorber upstream of every solenoid valve or quick closing valve. This applies also to NIC equipment having solenoid valves supplied by other divisions, such as washing machines, dishwashers, etc.
- .4 Review proposed location and type of shock absorbers with Contract Administrator prior to installation.

.4 Backflow Preventers

.1 Provide approved backflow preventers on all potable water supplies as noted on drawings, specified herein, or as required by provincial/municipal authorities. (Conbraco, Watts)

.2 Test backflow preventers in accordance with manufacturer's recommendations, Contract Administrator or as required by provincial/municipal authorities.

3.4 NATURAL GAS PIPING SYSTEM

.1 Make arrangements with gas utility company to bring in service and install meter and regulator. Pay all service and installation charges.

.2 Run piping as shown to serve equipment. Take out permits and connect equipment ready for use. Provide gas regulators as specified under Products section of this specification. Run vent piping from relief valves to atmosphere. Install gas piping in accordance with Provincial Department of Labour regulations. Provide gas cock at each piece of equipment. Provide drip pockets at each piece of equipment and at low points. Grade horizontal piping 1:500 (1" in 40 ft.) to drain through risers.

.3 All natural gas piping concealed above lay-in tile ceilings, in walls or other inaccessible locations shall have all welded joints and shall be stamped by the welder with his number.

.4 Where gas piping is welded, arrange with provincial authorities to inspect and provide written approval to Contract Administrator prior to system use.

3.5 JOINTING

.1 All joints shall be made in accordance with manufacturer's recommendations.

.2 Asbestos cement and cast iron soil pipe shall be installed as recommended by manufacturer. Fittings shall be braced where necessary to prevent joints coming apart under pressure.

.3 Cast iron hub and spigot soil pipe may be joined with oakum and lead, or Bibby Bi-Seal compression sleeve. Do not use oakum on hot water drain lines where suspended in finished area.

.4 Screwed joints in steel piping shall be made with full cut standard taper pipe threads, with approved non-toxic joint compound applied to male threads only. Joint compound shall not be applied to the first thread. Avoid squeezing excess compound into pipes. All pipes must be reamed or filed and left full bore, clean and free of scale.

- .5 Joints in copper drainage and water tube shall be in strict accordance with manufacturer's published recommendations and as follows:
- .1 Water tube up to and including 50mm (2") and drainage tube all sizes shall be lead free solder consisting of tin, copper and silver (Silvabrite 100 or equal).
 - .2 Water Piping over 50mm (2") shall be brazed (Sil-Fos). Valve bonnets and inner parts must be removed from valve bodies when silver brazing valves and adjacent joints.
- .6 Where black steel pipe and welding fittings are specified or permitted, welding to be performed by welder holding current welder's certificate from Provincial Department of Labour.

3.6 EXPANSION AND CONTRACTION OF PIPING

- .1 Make provision for expansion and contraction of all piping. Use swing connections where shown or necessary.
- .2 Install hot water supply and recirculation piping with expansion loops where required and anchor by approved rigid anchors, in order to control expansion.
- .3 Install expansion joints where shown on drawings. Provide anchors and guides as recommended by manufacturer.

3.7 CLEANING AND FLUSHING

- .1 On completion, flush out piping systems before installation of equipment, fixtures, etc. in order to remove any foreign material in piping.
- .2 Clean out all plumbing fixtures and equipment and leave in first class operating condition.

3.8 TESTING

- .1 All piping systems shall be pressure tested as follows:
 - .1 Plumbing, drainage and natural gas systems - in accordance with local regulations.
 - .2 Water supply piping - test with water to 690 kPa (100 psig) at the highest point of system. Maintain pressure without loss for 4 hours.

1.1 GENERAL

- .1 All drawings and all sections of the specifications shall apply to and form an integral part of this section.

1.2 WORK INCLUDED

- .1 Labour, materials, plant, tools, equipment and services necessary for and reasonably incidental to completion of services noted herein:

PART 2 - PRODUCTS

2.1 PIPE AND FITTINGS

- .1 Recovery Services.
.1 Pipe Diameter:
.1 13mm to 250mm (1/2" to 10")- Schedule 40 carbon steel, continuous weld or electric resistance weld pipe conforming to A.S.T.M. A53 Grade B.

2.2 AIR HANDLING PRODUCTS

- .1 General
.1 Air Handling Units shall be built to the level of quality as herein specified and to the description of the Air Handling Unit Schedule.
.2 Substitution of any product other than that specified, must assure no deviation below the stated capacities, air flow rate, heat transfer rate, filtration efficiency and air mixing quality. Power requirements must not be exceeded, and where specifically defined, sound power levels must not be exceeded. Applications for "equal" or "alternate" must address these factors.
.3 Unless stated otherwise, air handling units are to be shipped to the job in one piece, factory assembled. All equipment shall be factory tested prior to shipment.
- .2 Unit Construction
.1 Unit casing shall be of minimum 18 (1.3mm) gauge satin coat galvanized sheet metal. Surfaces shall be cleaned with a degreasing solvent to remove oil and metal oxides and primed with a two part acid based etching primer. Finish coat shall be an electrostatically applied enamel, at least 3 mils thick, to all exposed surfaces. All unprotected metal and welds shall be factory coated.
.2 All walls, roofs and floors shall be of formed construction, with at least two breaks at each joint. Joints shall be secured by sheet metal screws or pop rivets. Wall and floor joints shall be broken in and roof joints broken out
-

(exposed) for rigidity. All joints shall be caulked with a water resistant sealant.

.3 The following components shall be provided with a 22 gauge (.85mm) solid, or 24 gauge (.70mm) 40% free area) perforated galvanized metal liner over insulated areas: Solid Liner Perf. Liner

- .1 Fan Sections
- .2 Coil Sections
- .3 Filter sections
- .4 Access Sections
- .5 Underside of Unit

.4 Units shall be provided with access doors to the following components:

- .1 Fans and Motors
- .2 Filters
- .3 Dampers and Operators
- .4 Access Plenums

.5 Access Doors shall be large enough for easy access. Removal of screwed wall panels will not be acceptable. Doors to areas of negative pressure will open out, and to areas of positive pressure will open in.

- .1 Provide lift out access doors, secured with two or more camlock fasteners. Lift out doors over 36 in. (915 mm) high shall include a single lifting handle.
- .2 Provide hinged access doors, fully lined, with zinc plated piano hinges and brass pins, fully lined and secured with a minimum of two camlock fasteners for all units up to 48 in. (1220 mm) high.
- .3 Provide hinged access doors, fully lined, with zinc plated piano hinges and brass pins, Ventlock 310 handles, operable from both sides for all units over 48 in. (1220mm) high.
- .4 Provide hinged access doors, with zinc plated piano hinges and brass pins, in welded steel frames. Doors shall be fully lined, with closed cell, automotive bulb gasket and Ventlock 310 handles, operable from both sides.
- .5 Hinged access doors shall be provided with tie back clips.
- .6 Access doors shall incorporate 12" x 12" (305 mm x 305 mm) single pane tempered glass viewing window, wire reinforced or, double pane tempered sealed type.

.6 Casings shall be supported on formed galvanized steel channel or structural channel supports, designed and welded for low deflections. Integral lifting lugs shall be provided for hoisting.

.7 All units shall be internally insulated with 1" (25mm) thick 1-1/2 lb./cu.ft. (24 kg/m) density, neoprene coated fibre glass thermal insulation, shall secured to metal panels with a fire retardant adhesive and welded steel pins at 16" (400mm) o/c. 3 lb/cu.ft. (48 kg/cu.m.) insulation is secured with steel angles. All longitudinal insulation joints and butt ends shall be covered by a sheet metal break to prevent erosion of exposed edges. Drain pans and all floor areas shall be insulated on the underside.

.8 Unit casing floors in walk in sections shall be fabricated with 14 ga (2.0mm) galvanized checker plate steel, 14 pa checker plate steel with iron grip polyurethane coating. Provide reinforcing channels under floor to minimize deflection.

.9 Cooling unit drain pans shall be an integral part of the floor panelling, a minimum of 2" (50mm) deep, with welded corners and coated with an asphaltic water-proofing compound. Drain panels shall extend a minimum of 6" (150mm) downstream of coil face and be provided with a 1" M.P.T. drain connection. Drain pans must be sloped and pitched such that there is no standing water. Intermediate drain pans shall be provided between cooling coils above 65" (1650mm). Extend drain under complete fan section where fan is downstream of humidifier. Drain pans shall be stainless steel.

.10 Indoor suspended units shall be provided with 1/2" holes in the base channels to accommodate hanger rods (supplied by others).

.3 Fans

.1 Centrifugal fans shall be rated in accordance with AMCA Standard test Code, Bulletin 210. Fan manufacturer shall be a member of AMCA. All fans and fan assemblies shall be dynamically balanced during factory test run. Fan shafts shall be selected for stable operation at least 20% below the first critical RPM. Fan shafts shall be provided with a rust inhibiting coating.

.2 Single low pressure forward curved fans of 18" (450mm) or less diameter, shall be equipped with permanently lubricated cartridge ball bearings, supported by a 3 point "spider" bearing bracket in the fan inlets. All other forward curved fan assemblies shall be equipped with greaseable pillow block bearings, supported on a rigid structural steel frame.

.3 Forward curved fans shall have a ratio of blast area to nominal outlet area of 60% or greater, with airfoil fans at 75% or greater.

.4 Drives shall be adjustable on fan with motors 5 HP (3.73 kw) or smaller. On fans with larger motors, fixed drives shall be provided. All drives shall be provided with a rust inhibiting coating.

.5 Motor, fan bearings and drive assembly shall be located inside the fan plenum to minimize bearing wear and to allow for internal vibration isolation of the fan-motor assembly, where required. Motor mounting shall be adjustable to allow for variations in belt tension.

.6 Fan-motor assemblies shall be provided with internal vibration eliminators. Isolators shall be secured to welded steel channel and connected to the structural frame of the unit. The isolators shall be neoprene in shear type for single 9" (230mm) to 15" (380mm) forward curve fans.

.7 All single phase belt drive motor applications shall include rubber isolation for motors 1/4 H.P. (.19kw) through 1 1/2 H.P. (1.1kw). Provide internal spring isolation for single phase motors over 1 1/2 H.P. (1.1kw)

- .8 Provide extended grease lines terminating outside the serviceable side of the unit. Single grease line from fan side to access side bearing.
- .9 Provide extended grease lines terminating outside the serviceable side of the unit.
- .10 Provide fan scroll access doors and drains.
- .11 Fan motors shall be open drip proof, ODP totally enclosed TEFC, ODP high efficiency, TEFC high efficiency, explosion proof type.
- .4 Coils
- .1 Coils shall be manufactured by Engineered Air Copper tube, aluminum fin copper headers with schedule 40 steel pipe connectors, male N.P.T. Fins constructed of aluminum or copper shall be rippled for maximum heat transfer and shall be mechanically bonded to the tubes by mechanical expansion of the tubes. The coils shall have a galvanized steel casing. Coils with copper tubes shall have copper headers. All coils shall be factory tested with air at 300 psig (2070 kpa) while immersed in an illuminated water tank.
- .2 Headers shall be outside the air handling unit for maximum serviceability. A non-headered end of coil shall be fully concealed. Provide auxiliary drain pan complete with 1/2" (13mm) NPT drain connection at headered end of cooling coils.
- .3 Provide an insulated header cover to conceal exposed headers.
- .4 Coils shall be removable from the unit at the header end, unless shown otherwise on the drawings. All water coils shall be equipped with a capped vent tapping at the top of the return header, and a capped drain tapping at the bottom of the supply header.
- .5 Coils shall be cleanable type provided with brass fittings and removable plugs for each tube at return. Cast iron headers must have brass plugs to prevent oxidization.
- .6 Water and glycol coils shall be circuited to provide adequate tube velocities to meet design requirements.
- .7 Refrigerant coils with multiple compressors shall be alternate tube circuited in order to distribute the cooling effect over the entire coil face at reduced load conditions. Provision for use of thermal expansion valves must be included for variable air volume and/or make-up air applications.
- .5 Gas Heat Section (DJ, DJE) - Indirect Fired
- .1 General
- .1 Heating units shall be indirect natural gas fired approved for both sea level and high altitude areas. The entire package, including damper controls, fan controls, and all other miscellaneous controls and accessories shall be approved by and independent testing authority and carry the approval label of that authority as a complete operating package. Units to be completely assembled, prewired, and tested in a factory certified by the testing agency to build indirect fired packaged heating equipment. Acceptable testing agencies are, C-ETL, CGA, or CSA.

- .2 Operating natural gas pressure at unit(s) manifold shall be 7" (1750 Pa) w.c.
- .3 Gas fired units shall be approved for operation in -40°F (-40°C) locations.
- .2 Heat Exchanger
 - .1 Heat exchanger shall be a primary drum and multi-tube secondary assembly constructed of titanium stainless steel with multi-plane metal tubulators, and shall be of a floating stress relieved design. Heat exchanger shall be provided with condensate drain connection. The heat exchanger casing shall have 1" (25mm) of insulation between the outer cabinet and inner liner. Blower assemblies close coupled to duct furnace type heat exchangers are not acceptable.
 - .2 Units with optional high efficiency heat exchangers (DJE) shall be tested and certified to ANSI standards to provide a minimum of 80% efficiency throughout the entire operating range as required by ANSI/ASHRAE 90.1-1989. The manufacturer shall be routinely engaged in the manufacture of this type of high efficiency equipment.
- .3 Burner
 - .1 The burner assembly shall be a blow through positive pressure type with an intermittent pilot ignition system to provide a high seasonal efficiency. Flame surveillance shall be with a solid state programmed flame relay c/w flame rod. The burner and gas train shall be in a cabinet enclosure. Insulation in the burner section shall be covered by a heat reflective galvanized steel liner. Atmospheric burners, or burners requiring power assisted venting are not acceptable.
 - .2 Unit(s) incorporating discharge air control and wherever specified, shall include 15:1 turndown (HT burner) for all inputs in range from 100MBH to 1400MBH (29.3kw to 410kw). The high turndown burner minimum input shall be capable of controlling at 6.7% of its rated input without on-off cycling.
 - .3 Refer to DJ Controls section for heat exchanger/burner assembly operating efficiencies.
- .4 Venting
 - .1 Installation and venting provisions must be in accordance with C.G.A. Standard B149.1, ANSI Z223.1-1992, and local authorities having jurisdiction. Type A, L, and/or PS venting is required on indoor units.
 - .2 Optional indoor unit manufacturer supplied draft hoods for field installation to accommodate "B" type venting. "B" vent sizing must be per nationally recognized standards and/or local gas codes.
 - .3 Unit(s) to be sidewall vented. Sidewall venting shall be approved by a nationally recognized certification agency and the unit manufacturer must supply the air proving switch, wall cap, double acting barometric damper, and all necessary control interlocks.
- .6 Filters

-
- .1 Filter sections shall be provided with adequately sized access doors to allow easy removal of filters. Filter removal shall be from one side as noted on the drawings.
- .2
- .1 For units with filter banks 72" (1825mm) high or less, the filter modules shall be designed to slide out of the unit. Side removal 1" (25mm) or 2" (50mm) filters shall slide into a formed metal track, sealing against metal spacers at each end of the track.
- .2 Bag or cartridge type filters shall slide into an extruded aluminum track against a gasketed sealer strip. Associated 2" (50mm) prefilters shall slide into an integral track in the aluminum extrusion.
- .3 Refer to Clause 15800 Filters.
- .4 2" (50mm) Replaceable Media: Disposable glass fibre media type enclosed in permanent galvanized metal frame. (Permanent re-usable metal enclosing frame). The filter media shall have an average efficiency of 30% on AHRAE Standard 52-76.
- .5 Where filters are provided in air handling units for make-up air applications and where hoar frost may occur, only steel frame filters are acceptable. Where indicated, units shall have both summer (upstream of heating coil or gas heat exchanger) and winter (downstream of heating coil or gas heat exchanger) filter sections. Only one set of filters is installed depending on ambient conditions.
- .6 Filter media shall meet U.L. Class 2 standards.
- .7 Provide filter bank with "Dwyer 2000 magnehelic" air filter gauge, complete with static pressure tips and aluminum tubing, all factory installed. Filter gauge to have a range of 0 to 1 inch (0-250 Pa) 0 to 2 inch (0- 500 Pa). Where two or more filter banks are connected to a single gauge, multiple gauge kit with manual shut-off cocks in the air tubing shall be provided.
- .7 Dampers
- .1 Damper frames shall be hat-shaped galvanized metal sections securely screwed or welded to the air handling unit chassis. Pivot rods of 1/2" (13mm) aluminum shall turn in bronze bushings, fabricated from self-oiling bronze. Rods shall be secured to the blade by means of straps and set screws.
- .2 Blades shall be 18 gauge (1.3mm) galvanized metal with two breaks on each edge and three breaks on centreline for rigidity. The pivot rod shall "nest" in the centreline break. Damper edges shall interlock. Maximum length of damper between supports shall be 42 inches (1070mm).
- .3 Dampers shall be:
- .1 Standard construction for all dampers include blade ends sealed with an adhesive backed foamed polyurethane gasketting. Outdoor air dampers also include an all weather PVC seal, fastened with a positive lock grip and pliable overlap edge on entering air side of interlocking edges. Dampers are interlocked from the centre.
- .2 Low leak dampers shall include blade ends sealed with an adhesive backed foamed polyurethane gasketting. Interlocking blade edges shall include an all weather PVC
-

seal, fastened with a positive lock grip and pliable overlap edges on both the entering and leaving air sides. Pivot rods extend the full length of damper blades and are interlocked on the side through crank arms.

.3 Certified low leak dampers shall be tested and certified under AMCA Standard 500-89 by an accredited test laboratory. These dampers include: rigidly formed galvanized steel frame with corner reinforcing brackets; heavy duty galvanized damper blades secured with bolts to continuous 0.50 inch (13 mm) aluminum drive rods; all weather PVC double seal blade gasket; tempered aluminum alloy blade end seal, epoxy enamel coated; oil impregnated bronze bushings; and non-corrosive smooth acting linkage.

.4 Low leak certified low leak, dampers shall also be provided for return air dampers, exhaust (relief) air dampers.

.5 Mixing dampers shall be parallel blade type.

.6 Two position inlet dampers shall be parallel blade type.

.7 Face and bypass shall be opposed blade type.

.8 Multizone dampers shall be opposed blade type with the hot deck damper set at right angles to the cold deck damper.

.9 Motorized relief dampers shall be parallel; opposed blade type.

.10 Gravity relief dampers shall be single blade gasketed design.

.11 Provide Engineered Air mixers downstream of mixing box to provide through mixing and prevent stratification.

.8 Refrigeration

.1 Compressors shall be hermetic type, 3600 RPM, set on resilient neoprene mounts and complete with line voltage break internal overload protection, internal pressure relief valve and crankcase heater.

.2 From system start-up, as interpreted by Contract Administrator provide one year guarantee on equipment [with four (4) year extended warranty on all compressor motor assemblies].

.3 Condenser coils shall be copper tube type, mechanically expanded into aluminum fins. Coils shall be factory tested with air at 300 psig (2070 kPa) while immersed in an illuminated water tank.

.4 Condenser fans shall be direct driven propeller type arranged for vertical draw through air flow. Motors shall be weather resistant EAD 6 pole type, with integral overload protection and designed for vertical shaft condenser fan applications. Fan and motor assemblies shall be mounted on a formed orifice plate for optimum efficiency with minimum noise level.

.5 Split System Condensing Units

.1 Condensing units shall be C-ETL approved. Condensing units shall be designed for a minimum of 15 deg F (8 deg C) liquid subcooling. Condensing units shall operate down to 50 deg. F (10 deg C) as standard. Multiple compressor/condensor circuits shall be separate from each other. Suction and liquid lines shall be extended to the outside of the cabinet. Service ports fitted with Schraeder fittings

shall be connected to the suction and discharge lines for charging or pressure gauge readings. Semi-hermetic units shall also incorporate liquid line service ports and liquid line manual shutoff valves.

.2 Controls for hermetic compressor units shall include compressor and condenser fan motor contactors, control circuit transformer, cooling relays, recycling pumpdown relays, ambient compressor lockout, high pressure controls and automatic reset low pressure controls. Head pressure actuated fan cycling control shall be provided on all dual condenser fan units.

.3 Provide five minute anti-cycle timers.

.4 Provide interstage time delay timers.

.5 Provide hot gas bypass connection on the lead compressor.

.6 Refrigeration specialties such as solenoid valves, TX valves, etc., to be supplied and installed by refrigeration Contractor.

.9 Pre-Wired Equipment and Factory Installed Controls

.1 Air handling units shall be factory wired and tested, and shall be certified by C-ETL.

.2 Wiring shall be in accordance with the Canadian Electrical Code, Part 1, and pertinent sections of Part 2 of the Code pertaining to specific equipment type and purpose.

.3 All electrical circuits shall undergo a dielectric strength test (CSA C22.2-94), and shall be factory tested and checked as to proper function.

.4 Prewired air handling units shall bear an approved bilingual label with all the necessary identification marks, electrical data, and any necessary cautions as required by the Canadian Electrical Code, Part 2.

.5 Provide a system of motor control, including all necessary terminal blocks, motor contactors, motor overload protection, grounding lugs, control transformers, auxiliary contactors and terminals for the connection of external control devices or relays.

.1 Gas fired units shall also include high limit and combustion air flow switch.

.6 Automatic controls shall be housed in a control panel mounted in or on the air handling unit, which will meet the standard of the specific installation.

.10 DJ Control

.1 Electronic (Modulating Gas & Combustion Air)

.1 Solid state analyzer complete with proportional and integral control and with a discharge air sensor to maintain set point temperature and provide rapid response to incremental changes in discharge air temperature. Combustion air motor speed varies in response to the modulation of gas flow to provide optimum fuel/air mixture and efficiency at all conditions.

.2 Combustion efficiency of standard high efficiency heat exchangers shall increase 4 - 5% from high fire to low fire

on units incorporating 15:1 turndown (HT Burner). Heat exchangers shall provide a minimum of 78% 80% efficiency throughout the entire operating range.

- .2 Heating control function shall be:
 - .1 modulating discharge air
 - .2 modulating two level discharge air with discharge air temperatures set at either 60°F (15°C) to 100°F (38°C) when used with T874 or T7300 room thermostat.
 - .3 Variable room control with a discharge sensor to limit the minimum and maximum discharge temperatures. Units(s) to modulate gas and combustion air to match exact load with discharge range from 60°F (15°C) to 100°F (38°C).
 - .4 modulating discharge air reset from BMS system (0-10v or 4-20 ma). Minimum discharge air setpoint is 50°F (10°C) if BMS control fails (Reset obtained via CTRAC for heat/cool units).
- .3 Cooling Control
 - .1 Electro-Mechanical
 - .2 Engineered Air CTRAC electronic temperature control system with the capability of providing up to 5 stages of cooling control to maintain discharge (room) temperature. The minimum run and off time for compressors shall be 4 minutes at full load startup, and may range up to 8 minutes under part load conditions. The CTRAC shall incorporate a PI (proportional/integral) control scheme that reduces temperature drop by resetting to the set point after each stage is cycled on. CTRAC shall include:
 - .1 CTRAC shall include an integrated economizer cycle that will provide the initial response to a call for cooling. The temperature of the mixed air will vary in response to the demand for cooling. After the outside air dampers are fully open, and further cooling is demanded: (Three options are available):
 - .1 The outside air dampers revert to their minimum position and stage 1 cooling is energized.
 - .2 Provide an adjustable deadband range between heating and cooling from 2°F to 11°F. While in the range, the outside air dampers shall be in minimum position.
 - .2 In heating range, the CTRAC will provide a signal to one of the following second level devices:
 - .1 Model DJM controller for Series DJ industrial heater as specified.

2.3 GAS-FIRED HEATING AND VENTILATION SYSTEMS

- .1 Installation to conform to C.G.A. and C.S.A. requirements and manufacturers published recommendations.
- .2 Unit to be field assembled. Transition ducts from fan to last duct heater by Section 15800.

.3 Unit to be set for % outside air minimum, % outside air maximum.

2.4 CO-ORDINATE WITH H.V.A.C. BALANCE AND TESTING AGENCY

.1 Refer to Section 15990 H.V.A.C. Balance and Testing.

.2 Air balancing Work shall not begin until system has been completed and in full working order. Section 15600 shall put all heating, ventilation, and air conditioning systems and equipment into full operation, as season would demand, and shall continue operation of same during each working day of testing and balancing. Co-ordinate Work with Section 15990.

.3 As part of this Contract, Section 15600 shall make any changes in pulleys and belts, and add manual dampers for correct balance as recommended by Section 15990, at no additional cost to The City.

.4 Section 15600 responsible for initial alignment and tension of all fan pulleys and belts of equipment supplied by Section 15600.

2.5 HEAT RECOVERY SYSTEMS

.1 For each heat recovery system, coil manufacturer shall submit to Contract Administrator with shop drawing, computer print-out containing following information:

.1 Entering and leaving air temperatures for supply and exhaust coils.

.2 Entering and leaving glycol temperatures for supply and exhaust coils.

.3 Air and glycol pressure drops through supply and exhaust coils.

.4 Quantity of heat transferred from exhaust air to supply air at minimum outside air temperature of -34.4 deg. C.

.5 Quantity of heat transferred from exhaust air to supply air per heating season.

.6 Net saving per heating season with consideration to:

.1 Additional power required for both supply and exhaust fans.

.2 Power required for glycol circulating pumps.

.3 Base calculations on heat source costing (cents) per kWh. (Heat cost is produced cost and not fuel cost.)

.4 Use Winnipeg weather data for an average heating season.

.2 Do not heat supply air above +12.8 deg. C.

.3 Air resistance through coils shall not exceed values listed in Schedule.

.4 Control system will prevent glycol temperature entering exhaust coils from going below -1 deg. C.

- .5 Refer to Glycol Heat Recovery Schedule for heat recovery system requirements.

1.1 GENERAL

- .1 All drawings and all sections of the specifications shall apply to and form an integral part of this section.

1.2 WORK INCLUDED

- .1 Labour, materials, plant, tools, equipment and services necessary and reasonably incidental to completion of air conditioning and/or ventilation Work.

1.3 RELATED WORK SPECIFIED ELSEWHERE

- .1 Section 15010 Mechanical General Provisions
- .2 Section 15180 Insulation
- .3 Section 15400 Plumbing
- .4 Section 15600 Liquid Heat Transfer
- .5 Section 15900 Controls/Instrumentation
- .6 Section 15990 Testing, Adjusting and Balancing
- .7 Section 16010 Electrical General Provisions

PART 2 - PRODUCTS

2.1 DUCT OPENINGS

- .1 Pack area between ducts and openings with fireproof self-supporting insulation. Seal with 25mm (1") mastic topping.
- .2 Use 1.2mm (18 ga.) galv. iron sleeves where ductwork passes through mechanical room and kitchen floors. Sleeves to extend 150mm (6") above floor. Use watertight mastic between sleeve and floor material.

2.2 DUCT AND EQUIPMENT SUPPORTS, HANGERS AND INSERTS

- .1 Support horizontal ducts on maximum 2.4m (8'0") centres by non perforated galv. steel, rivetted strap for ductwork 900mm (36") (either dimension) or less, and minimum 25mm x 25mm x 3mm (1" x 1" x 1/8") galv. angle iron passing under ducts 925mm (37") or over (either dimension) with 9.4mm (3/8") diam. threaded rods suspending angles from structure.
-

- .2 Support vertical ducts at every floor with angle iron collars sized to provide proper bearing.
- .3 Use universal concrete type inserts of black malleable iron, for threaded connection with lateral adjustment, top slot for reinforcing rods and lugs for attaching to forms.

2.3 APPARATUS CASINGS

- .1 Construct plenums, casings, partitions, baffles, etc., used to connect component parts of air supply units, exhaust plenums and similar built-up air-handling units, of 1.6mm (16 ga.) U.S.S. prime quality galv. steel panels.
- .2 Join sidewall and roof panels with 37mm (1-1/2") standing seam.
- .3 Angle Sizes
 - .1 Casing length 3.65m (12'-0") and under -37mm x 37mm x 3mm (1-1/2" x 1-1/2" x 1/8")
 - .2 Casing length over 3.65m (12'-0") - 44mm x 44mm x 4.7mm (1-3/4" x 1-3/4" x 3/16").
- .4 Plenum walls and casings on equipment room floors to have a 150mm (6") concrete curb.
- .5 Where casing joins masonry walls, rivet panels 150mm (6") o.c. panels to 37mm x 37mm x 3mm (1-1/2" x 1-1/2" x 1/8") galv. steel angle secured to masonry with expansion shields and bolts on 609mm (24") centres, caulked airtight.
- .6 Where casing joins floor, imbed 100mm x 37mm x 3mm (4" x 1 1/2" x 1/8") galv. steel angle into 50mm (2") of the concrete curb for airtight installation. Connect plenum to other 50mm (2") of angle. Caulk airtight.
- .7 Each section from outside air intake to discharge ductwork to have 609mm (24") x 1.2m (48") access doors or of sizes noted. Doors of double thickness with insulation between outside and inside panels. Locks to be operative from both sides. Frame openings above and below door with 37mm x 37mm x 3mm (1-1/2" x 1-1/2" x 1/8") galv. angle spanning between vertical seams. Frames welded into place. Doors to be rubber gasketed, with two heavy sash fasteners for airtight fit.

2.4 LOW PRESSURE DUCTWORK

- .1 Low Pressure Rectangular Ductwork Schedule

| <u>Max. Side</u> | <u>Bracing</u> |
|---------------------------|----------------|
| .1 Up to 600mm(24") | None |
| .1 Gauge: .60mm (24 USSG) | |

- .2 635mm to 750mm (25" to 30") 25mm(1")x 25mm(1") x 3.2mm(1/8") angle, 1.2mm(4'0") from joint.
 - .1 Gauge: .60mm (24 USSG)
- .3 785mm to 1000mm (31" to 40") 25mm(1")x 25mm(1") x 3.2mm(1/8") angle, 1.2mm (4'0") from joint.
 - .1 Gauge: .80mm (22 USSG)
- .4 1040mm to 1.5m (41" to 60") 37.5mm(1-1/2") x 37.5(1-1/2") x 3.2mm(1/8") angle, 1.2m(4'0") from joint.
 - .1 Gauge: .80mm (22 USSG)

.2 Round Ductwork Schedule

- | | <u>Duct Diameter</u> | <u>Gauge</u> |
|----|-----------------------------|-----------------|
| .1 | Up to 508mm (20") | 0.5mm (26 USSG) |
| .2 | 533mm to 1.02m (21" to 40") | 0.6mm (24 USSG) |

- .3 Ductwork to be galvanized steel unless noted otherwise.
- .4 Outdoor ductwork to be two gauges heavier than directed above.
- .5 Turning vanes (Ducturns)
 - .1 Use duct elbows which have throat radius of 1-1/2" times the diameter.
 - .2 Where use of above specified item is precluded by space limitations, use duct elbows fabricated square throats and backs and fitted with Rovane turning vanes.
 - .3 Standard of Acceptance: S.E. Rozell & Sons Limited, Kitchener, Ontario.
- .6 Provide E.H. Price AE-1 c/w #3 operator at all supply registers.

2.5 MANUAL VOLUME DAMPERS

- .1 1.2mm (16 ga.) galv. steel stiffened, blades of louvre type. Maximum of 300mm (12") wide and 1.8m (72") long, with one centre and two edge crimps. Damper hardware to be Duro-Dyne KS-145, KS-385 or KS-12 as recommended by manufacturer.

2.6 MOTORIZED DAMPERS

- .1 Supplied by Section 15900 for installation by Section 15800, with exception of those supplied with factory assembled:
 - .1 air-conditioning units
 - .2 heating and ventilating units
 - .3 factory fabricated preheat coils and by-pass units
 - .4 fan vortex dampers

2.7 RELIEF AIR BACKDRAFT DAMPER

- .1 Provide Penn CBD-6 heavy duty counter-balanced backdraft damper where noted.
- .2 Counter-balanced weights to be field adjustable for fine tuning.
- .3 Units shall be capable of operating in both horizontal and vertical plane.
- .4 Blades to be aluminum roll formed blades that pivot in ball bearings.
- .5 Frame to be heavy duty galvanized steel.

2.8 FIRE DAMPERS

- .1 Install U.L.C. labelled fusible link folding blade fire dampers as manufactured by Air Balance of Canada Limited in fire separations where shown, and where otherwise required by authorities having jurisdiction. Fire dampers shall conform to the most recent issue of N.B.C. Fire dampers and fusible links shall be tested and approved by ULC or other Testing Agency recognized by the authorities having jurisdiction. Fusible links shall be readily removable by hand for testing without use of auxiliary equipment such as pliers.
 - .2 Depending on the rating of fire separation, based on architectural drawing and specifications, the rating, construction and testing of fire dampers shall meet the following:
 - .1 N.B.C.
 - .2 ULC S 112
 - .3 NFPA 252
 - .4 ULC or ULI 10(b)
 - .5 Authorities Having Jurisdiction
 - .3 Use type 'B' fire dampers, i.e. blades out of air stream, in all ducts passing through fire separations. Use combination fire damper-balancing damper, with blades in air stream, on sidewall supply or return or floor mounted supply registers, up to maximum size of 0.372m (576 sq.in.). For all sidewall return grilles or sidewall return registers above 0.372m (576 sq.in.) in size, use a type 'A' fire damper, i.e. blades in the air stream.
-

2.9 DUCT ACCESS DOORS

- .1 Install airtight, 25mm (1") internal glassfiber insulated access doors in ductwork as noted and at all humidifier dispersion tubes, motorized dampers; at inlet and outlet of vaneaxial and axial fans; at inlet of heating coils; at fire dampers and locations noted on drawings.
- .2 Access doors at fire dampers, fire/smoke dampers and smoke detectors shall be minimum 300mm (12") x 300mm (12") or larger to fully access and replace fusible link. Enlarge duct as required.

2.10 LOUVRES AND WALL OPENINGS

- .1 Provide where shown, Airolite Type K609HP extruded aluminum louvres. Blades and frames of 1.8mm (12 ga.) (.081) 6063-T5 extruded aluminum alloy, spot welded to flange legs of side channels. Provide flange extension to butt to back of wall. Assemble all louvre parts by welding. Spot weld all flanges to frame members on maximum 150mm (6") centres. Mullions, as required, to have cover plates attached to louvre section with No. 10 trusshead aluminum screws on 300mm (12") maximum spacing.
- .2 Units c/w 12mm (1/2") square mesh 1.6mm (16 ga.) aluminum birdscreening with standard folded frame on louvres and outside openings not having louvres.

2.11 FILTERS

- .1 General:
 - .1 Fan manufacturer to provide filter in filter sections provided with equipment.
 - .2 Filter supplier to provide all other filters.
 - .3 Provide one spare set of filter media for each filter bank.
 - .4 Section 15800 shall fabricate filter sections not provided with equipment. Provide access panels c/w cam-lock fasteners, on each side of filter section. Access doors shall also have gaskets that butt against the filter frames to eliminate bypassing of air filters. Filter banks exposed to the outdoors shall have stainless steel piano hinges.

2.12 BELT DRIVEN VENTILATING SETS

- .1 CML Northern Blower belt driven A.V.S. or S.Q.I. airfoil ventilating sets as noted c/w steel housing, adjustable motor support. Fan motor specified to minimum size accepted. Provide common motor and fan support to keep fan and motor stable.
 - .2 Exhaust fans to have attached backdraft damper except when motorized dampers are specified on system.
-

- .3 Weatherproof discharge cowl and birdscreen and a weatherproof motor and drive cover on all fans located on roof or outside buildings.
- .4 Refer to Cl. Fan Systems - General for fan drive requirements.
- .5 Units to have 37mm (1-1/2") deflection spring isolators.
- .6 Refer to clause 'Fan Systems - General'.
- .7 Fans connected to kitchen exhaust hoods shall have drain in housing and access doors for cleaning housing and wheel.
- .8 Refer to Fan Schedule.

2.13 IN-LINE BELT DRIVEN VENTILATING SETS

- .1 Greenheck Fan Model BSQ In-Line Belt Drive Fan
 - .1 Duct mounted, centrifugal belt drive in-line type.
 - .2 The fan housing of the square design constructed of heavy gauge galvanized steel, square duct mounting collars.
 - .3 Fan construction shall include two removable access panels located perpendicular to the motor mounting panel. Access panels of sufficient size to permit access to all interior components.
 - .4 Centrifugal backward inclined, fan wheel, constructed of aluminum wheel cone matched to the inlet cone for precise running tolerances. Wheels statically and dynamically balanced.
 - .5 Motors shall be heavy duty ball bearing type, matched to fan load, furnished at the specified voltage, phase and enclosure. Motors and drives shall be mounted out of the airstream. Motors shall be readily accessible for maintenance.
 - .6 Precision ground and polished fan shafts mounted in permanently sealed, lubricated pillow block ball bearings. Bearings shall be selected for a minimum (L50) life in excess of 200,000 hours at maximum catalogued operating speed.
 - .7 Drives sized for a minimum of 150% of driven horsepower. Pulleys fully machined cast iron type, keyed and securely attached to the wheel and motor shafts.
 - .8 Motor pulleys adjustable for final system balancing. A NEMA-1 disconnect switch. Factory wiring shall be provided from motor to handy box.
 - .9 All fans shall bear the AMCA Certified Ratings Seal for both sound and air performance.
 - .10 Each fan shall bear a permanently affixed manufacturer's nameplate containing the model number and individual serial number for future identification.
 - .11 Refer to Fan Schedule.
-

2.14 CEILING MOUNTED EXHAUST FANS

- .1 Ceiling exhaust fans c/w removable fan-motor assembly, direct drive, backdraft damper. Specified fan speed maximum acceptable.
- .2 Provide matching wall vents, goosenecks or roof jacks all c/w backdraft dampers as required.
- .3 Where units in rated ceiling, provide special inlet grille c/w fire damper and access door in inlet duct plenum to remove fan unit for servicing.
- .4 Section 15800 responsible for ensuring that units have CSA approval for the particular application, prior to shop drawing submittal.
- .5 Refer to Fan Schedule.

2.15 RANGE HOOD

- .1 Provide removable fan-motor assembly, direct drive, aluminum mesh charcoal filter, backdraft damper. Specified fan speed maximum acceptable.
- .2 Unit to have fully variable speed fan control.
- .3 Provide matching wall vents, goosenecks or roof jacks all c/w backdraft damper as required.
- .4 Refer to Fan Schedule.
- .5 Unit to have light under hood.

2.16 AIR COOLED CONDENSING UNITS

- .1 Engineered Air air cooled condensing unit as noted.
 - .1 The condensing unit shall be completely factory assembled on a rugged steel channel base and be individually performance tested at full and part load conditions. The unit shall be leak tested and shipped with a holding charge for Refrigerant 22. Construction and ratings shall be in accordance with latest ARI Standard 520 and shall comply with ANSI/ASHRAE 15 Safety Code, National Electrical Code, CSA and ETL.
 - .2 Cabinet
 - .1 Unit casing and all structural members shall be fabricated of continuous galvanized steel and galvanized steel channel. Exterior casing shall be phosphatized and painted with a beige urethane finish.
-

-
- .3 Compressor
- .1 Compressor shall be tandem scroll (dual compressor, single circuit) type with suction and discharge Shrader parts, oil crankcase heater and suction strainer. Compressor shall have force feed lubrication system with reversible oil pump and operating oil charge. Compressor motor shall be refrigerant gas cooled. Compressor shall be mounted on vibration isolators to minimize noise and vibration transmission.
- .4 Condenser Coils
- .1 The condenser coils shall be constructed of 3/8" O.D. seamless copper tubes mechanically expanded into plate type aluminum fins. The fins shall have full drawn collars to completely cover the copper tube and protect against atmospheric corrosion. A subcooling coil shall be an internal part of the main condenser coil.
- .5 Condenser Fans and Motors
- .1 Condenser fans shall be propeller type arranged for vertical air discharge and shall be individually driven by direct drive fan motors. Fan blades shall be steel with a black paint finish or unpainted aluminum. Each fan shall be protected by a heavy-gauge fan guard. Condenser fan motors shall be 1-phase, direct drive, 1140 RPM, open drip-proof type positioned within the unit cabinet for weather protection.
- .6 Controls
- .1 Field power connection, control interlock terminals and unit control system shall be centrally located in a weatherproof enclosure. A sheet metal barrier shall protect service personnel against accidental contact with line voltage components. Power and starting components shall include factory fusing of fan motors and control circuit, starting contactors including individual contactors for each fan motors, solid-state compressor sequence start timer, solid-state compressor overload protection in all three phases, inherent condenser fan motor overload protection, and unit power terminal block for field connection to remote disconnect switch.
- .2 Safety and operating controls shall include control stop switch, recycling pumpdown control, high and low pressure switches and fan cycling controls. Unit to be c/w 120V control circuit transformer. Unit controls shall provide recycling pumpdown protection at all times, including time clock system shutdowns on nights and weekends.
- .7 Low and High Ambient Operation
- .1 Units shall be provided with automatic head pressure control to permit satisfactory operation at ambient air temperatures down to 50 deg. F. by cycling condenser fans in response to refrigerant head pressure and ambient air temperature.
- .2 Unit shall be rated for operation at ambient air temperatures up to 120 deg.F. (Design ambient based on 95 deg.F).
-

- .8 Refrigerant Piping
 - .1 The refrigerant circuit shall include a hot gas muffler, a manual liquid line shutoff valve with charging connection and purge valve.
- .9 Exposed Copper and Brass
 - .1 All exposed copper and brass on the unit shall be treated and protected against an ammonia environment. Condenser coils shall be completely dipped in a phenolic coating and then baked.
- .10 Provide factory-wired, 24 volt control circuit with internal fusing.
- .11 For each DX coil, provide thermo-expansion valve with remote bulb, solenoid pilot control valve with filter drier and liquid line angle filter drier.
- .12 Provide spring vibration isolators with rubber stabilizer and rubber base pad under entire unit.
- .13 From system start-up, as interpreted by Contract Administrator, provide one year guarantee on equipment.
- .14 Systems having two independent 50% capacity refrigerant circuits to have time delay to prevent simultaneous starting and automatic standby operation. Review cooling coil specifications for compatibility with refrigerant circuits. Units considered equal may have single circuiting provided that two step 100% capacity modulation by cylinder unloading is included.
- .15 Provide control package to allow compressors to function properly at minimum cooling loads. In general, units must have hot gas by-pass on final stage. Suction gas control is acceptable, but if manufacturer requires additional control method to maintain warranty on condensing unit equipment, then provide manufacturer's recommended auxiliary system acceptable to Contract Administrator. Units shall be provided with integral discharge air temperature control package consisting of discharge air temperature sensor and controller. Co-ordinate with Section 15900 Sub-Trade.
- .16 Refer to Condensing Unit Schedule.

2.17 REFRIGERANT PIPING AND ACCESSORIES

- .1 All refrigerant piping to be type 'L' copper with long radius elbows. All joints to be brazed with Silfos. Continuously bleed oil-free nitrogen through piping when brazing to prevent oxidation of internal pipe surface. All piping to be installed in accordance with good refrigerant piping practice with minimum number of fittings to minimize friction loss. Pipe sizes as

specified in schedule on detail sheet. Provide separate piping for split refrigerant circuits.

- .2 Provide flexible vibration eliminators on liquid and suction pipe connections to condensing unit.
- .3 Install refrigerant controls supplied by condensing unit manufacturer. Install thermo-expansion valve on each DX coil liquid line with external equalizer connection. Valve c/w external remote bulb, set to provide 5.5 deg C superheat. Install solenoid pilot control with filter drier in external equalizer line for on-off control of refrigerant flow. Install Henry angle drier immediately upstream of thermo-expansion valve. Provide Henry sight glass between drier and valve only on DX coils located above air cooled condensers.
- .4 Provide initial charge of refrigerant R22 and oil, as well as any additional amounts required during system warranty.
- .5 Provide manual valves as required to isolate individual system components to minimize refrigerant loss during replacement of individual components. Valves welded/brazed with Silfos to copper piping. No flare or compression fittings. No ball valves. Valves up to 5/8" - packless line by Streamline; 7/8" and larger - packed line by Globemaster, Streamline or Henry.
- .6 Provide refrigeration equipment manufacturer - approved wiring diagram illustrating all electrical wiring for refrigeration system.

2.18 COOLING COILS (REFRIGERANT)

- .1 DX coils with 15.6mm (5/8") O.D. copper tube, aluminum fins; 1.6mm (16 ga.) steel casing.
- .2 Distributor to be low pressure drop Venturi type with male sweat connections. Max. of 12 refrigerant circuits supplied from single distributor. Where more than 12 circuits, use two distributors. Refrigerant distributed from multi-outlet distributor to coil circuits through equal resistance, round, seamless copper tubing.
- .3 Coil shall be split, if required, to match condensing unit.
- .4 Test coil at 2067 kPa (300 psi) air pressure under water, dehydration, dry nitrogen charging and sealing before shipment.
- .5 Refrigerant coils suitable for working pressures to 1722 kPa (250 psi). Refrigerant R-12 or 22 as specified.
- .6 Coil manufacturer shall provide removable insulated covers over ends of cooling coils for protection against condensation and for access to coil headers and tube ends.

.7 Refer to Coil Schedule.

2.19 ACOUSTIC DUCT INSULATION

- .1 J-M Linacoustic flexible duct insulation with flame-attenuated glass fibers bonded with thermosetting resin. Black plastic-coated mat finish. Provide where noted on drawings and/or as specified herein.
- .2 Insulation to be fungi and bacteria resistant so as not to breed or promote growth. (ASTM G21, ASTM G22).
- .3 Provide protective 1.6mm galvanized iron walkway on floor of ducts and/or plenums requiring servicing.
- .4 Round Low Pressure Ducts
 - .1 Where indicated on drawings use 25mm (1") J-M Linacoustic.
- .5 Rectangular Low Pressure Ducts
 - .1 25mm (1") Thickness
 - .1 Ducts indicated as being acoustically lined on the drawings, unless noted otherwise.
 - .2 50mm (2") Thickness
 - .1 Ductwork indicated as being acoustic lined with 50mm (2") acoustic lining on drawings and specification details.
 - .2 Combustion air ductwork.
 - .3 Outside air intake ductwork from inlet up to the fan filter sections.
 - .1 Location: Fan Systems F-
 - .4 Outside air intake ductwork from inlet to point 900mm (3'-0") downstream of mixing box. Remainder shown to be 25mm (1") acoustic lining.
 - .1 Location: Fan Systems F-
 - .5 All ductwork, noted as having acoustic that is outside building structure.

2.20 CHIMNEY AND BREECHING

- .1 Breeching
 - .1 Breeching to be black iron, welded, gastight. Use 1.6mm (16 ga.) for sizes less than 605mm (24") diameter and 2.5mm (12 ga.) for sizes 605mm (24") diameter and larger.
 - .2 Chimneys to Metalbestos type 'B' gas vents c/w rain caps, roof flashing plates, inspection caps and tee connections for vent connectors and breechings.
 - .3 Provide type 'A' chimney with inner flue and outer casing of type 444 stainless steel with high temperature fireproof insulation between the inner flue and outer casing. Provide all necessary tee connections, starter box, base tee, fire stop spacers, rain cap, roof flashing, etc. to make complete
-

installation in accordance with manufacturer's recommendations and applicable codes.

- .4 Vent connectors from atmospheric gas fired hot water tanks, furnaces and atmospheric gas fired boilers shall be 1.2mm (18 ga.) (aluminum) with locked longitudinal seams and slip type connections between sections fastened with sheet metal screws.

2.21 CLEANING OF H.V.A.C. SYSTEMS

- .1 Cleaning of H.V.A.C. systems shall be performed by a competent sub-trade to Section 15800 - Air Distribution.
 - .2 Segregate points of access to fan chambers, plenums, larger diameter ducting etc. from adjacent Occupied Areas.
 - .3 Supply and install access doors in ductwork, plenums, etc. at locations required to complete Work specified.
 - .4 Work shall include the cleaning of new plenums, diffusers, air handling units, fans and all other mechanical equipment which combined forms part of the building's ventilation system. This shall include, but not be limited to the following:
 - .1 Interior surfaces of supply and return ductwork.
 - .2 Interior surfaces of supply and return air handling units to include, but not be limited to, plenums, fan(s), fan chambers, coils, dampers, filters, motor(s), louvres, etc.
 - .3 Surfaces of coils, dampers, louvres, turning vanes, diffusers, registers, grilles and all other equipment present within or which forms part of the supply or return air distribution system.
 - .5 Schedule Work following the completion of all Work by other trades that may generate airborne construction debris. Ensure Work of this section is completed prior to re-starting or testing of the building ventilation system or re-occupancy by The City.
 - .6 Ensure electrical power supply to air handling equipment, fans, etc. is locked out and tagged. System is to remain inoperable throughout the cleaning process. Tags shall be labelled as follows:
 - DANGER
 - Do Not Operate
 - Men Working on Equipment
 - .7 Use of compressed air to aid the cleaning process is only permitted where access by the worker is not possible and the use can safely be controlled by the worker from the exterior of the ducting. Use of compressed air by a worker or while a worker is present within larger diameter ducting, air handling equipment, plenums, etc. is strictly prohibited.
-

- .8 Robotic Brushing System
 - .1 Brushing system must have the capability to brush all four sides of the ductwork regardless of configuration and size.
 - .2 Brushing system must be capable to turn at a minimum of 400 R.P.M. in order to keep the debris suspended in the air flow, this allows all the contaminants to be propelled toward the vacuum.
 - .3 Brushing system must be capable of cleaning ductwork 2 inches and larger, and yet capable of making all 90 degree turns while in operation.
 - .4 The cleaning of insulated main ducts and the flex hose on the off shoots must be brushed and kept in its original condition. The system must be able to brush the duct without damage to the insulated duct, as well as not causing further damage to any existing deterioration.
 - .5 Every foot of the ductwork must be brushed in order to ensure proper cleaning.
 - .6 All equipment should be of a portable nature in order to operate in the Work place with all of the entrances in their usual operating state (i.e. all doors and windows closed) in order to ensure the organizations existing security measures.
 - .7 Brushing system must have the capability of brushing congruently with the compressed air at a minimum of 150 P.S.I.

- .9 H.E.P.A. Vacuum System
 - .1 Portable power vacuum system shall be capable of a minimum 4,000 C.F.M. of air movement.
 - .2 Portable vacuum system which exhausts into the workplace or other occupied areas, shall be equipped with H.E.P.A. filtrations 99.97% efficient for particles no greater than 0.3 microns in size.
 - .3 All systems should have the capability to film and record all of the ductwork before and after, or while in operation, if requested.

PART 3 - EXECUTION

3.1 DUCT OPENINGS

- .1 Locate only openings in walls, floors, partitions, beams, etc. required for ducts, equipment, etc. Contractor to form all openings for same, except as noted below.

3.2 DUCT AND EQUIPMENT SUPPORTS, HANGERS AND INSERTS

- .1 Design, Installation
 - .1 Supports to secure ducts and equipment, prevent vibration and provide for expansion and contraction. Design supports of strength and rigidity in a manner which will not stress the building construction. Use inserts for suspending hangers. Do not
-

use vertical expansion shields without Contract Administrator's approval.

.2 Concrete Inserts

.1 Do not weaken concrete or penetrate waterproofing membrane. Use reinforcing rods through inserts for pipe sizes over 50mm (2"), or equivalent weight. Where concrete slab is finished ceiling, inserts to be flush with surface.

.3 Protect insulation at contact with hangers and support with approved metal shields.

3.3 CO-ORDINATION WITH H.V.A.C. BALANCE AND TESTING AGENCY

.1 Refer to Section 15990 H.V.A.C. Balance and Testing. Co-ordinate Work with Section 15990.

.2 As a part of this Contract, Section 15800 shall make any changes in pulleys and belts, and add manual dampers for correct balance as recommended by 15990, at no additional cost to The City.

.3 Section 15800 responsible for initial alignment and tension of all fan pulleys and belts, of equipment supplied by Section 15800.

3.4 LOW PRESSURE DUCTWORK

.1 Where duct width exceeds 450mm (18") in largest dimension, stiffen by cross breaking sheets diagonally. Beaded ducts as per SMACNA Catalogue Fig. 1.13 acceptable alternative.

.2 Duct sizes are inside dimensions. If ducts are acoustically lined, outside duct size to be increased as required.

.3 Provide ductturns in all elbows of ducts 1200mm (48") wide and greater, in segments of 600mm (24") maximum.

.4 Single thickness partitions between ducts not accepted.

.5

.1 All ductwork shall have seams and joints sealed watertight with Duro-Dyne S-2 duct sealer and FT-2 fibreglass duct tape. Prior to installation ductwork to be clean, dry and free of grease. Apply duct sealer with stiff brush or trowel. Wrap wet seam or joint with duct tape and apply further coat of duct sealer. Duct sealer and glassfiber to extend 25mm (1") on each side of joint or seam. On outside ductwork construct duct so that top of duct slopes 12mm (1/2") per 300mm (12") minimum to ensure that water does not collect on top.

.2 Ductwork exposed in finished rooms do not require duct tape application, but seams and joints shall be sealed with S-2 duct sealer. Sealer must be capable of accepting finish painting.

.3 Ductwork on roof shall have seams and joints sealed by application of TREMCO MONO black acrylic sealant applied with application gun and levelled with putty knife. Material shall be used in accordance with manufacturer's printed recommendations.

- .6 Provide openings for thermostats and controllers by Section 15900.
- .7 Where ductwork conflicts with mechanical and electrical piping and it is not possible to divert ductwork or piping to stay within allowable space limitations, provide duct easements. Easements not required on pipes 100mm (4") and smaller outside dimension, unless this exceeds 20% duct area. Irregular or flat shaped piping requires duct easement. Hangers and stays in ductwork to be parallel to air flow. If easement exceeds 20% of duct area, duct to be split into two ducts with original duct area being maintained. Easements to be approved by Contract Administrator before installation.
- .8 At points within air system where air streams at different temperatures meet, install baffling for a good mix. Baffling to be by Section 15800 in locations recommended by Section 15900, approved by Contract Administrator, and at no additional cost to The City.
- .9 If ductwork is not adequately braced and/or supported to provide good installation, additional bracing and/or supports to be provided at no extra cost to The City. Contract Administrator to interpret.
- .10 Assemble round duct sections using beaded couplings attached with sheet metal screws.
- .11 Every intake and exhaust duct up through the roof shall be installed with a 2" (50mm) deep water-tight drip pocket at base of duct complete with drain, unless noted otherwise. Refer to specification details. This shall not apply to kitchen exhaust systems. Refer to plans for drain requirements.

3.5 MANUAL VOLUME DAMPERS

- .1 Install, in manner acceptable to manufacturer, where noted on drawings.

3.6 MOTORIZED DAMPERS

- .1 Units in acoustically lined ducts are to be sized to suit clear dimensions of acoustic insulation and not of size to suit sheet metal duct. Where units are located in acoustic lined ducting, install heavy gauge metal channel and fasten to metal duct to
-

receive damper frame. Space between channel and duct to be filled with flexible insulation.

- .2 On plenums and ducts with external insulation, Section 15900 to provide channel mounting frame of same thickness as insulation. Pack channel frame with loose fibreglass insulation.

3.7 FIRE DAMPERS

- .1 Fire dampers shall be installed in the plane of the fire separation so as to stay in place should the duct be dislodged during a fire. Install fire dampers only in positions for which they have been tested. Refer to specification details.
- .2 Installation shall conform to N.B.C. 1995 and local authorities.

3.8 DUCT ACCESS DOORS

- .1 Locate properly for inspection and servicing. Doors and frame to be rigid, close-fitting, with rubber gaskets, galvanized hinges with brass pins and at least two galvanized cam locks. Rivet frame and hardware to ducts.
- .2 Where impossible to swing access doors, install removable door with four cam locks.
- .3 Access doors for humidifier application shall be liquid tight, and installed on side of duct (not bottom).

3.9 LOUVRES AND WALL OPENINGS

- .1 Flash and make all openings around the louvres and wall openings weathertight. Slope ductwork down to louvre. Drill drain holes in bottom blade of louvre. Seal ductwork with Duro-Dyne S-2 until watertight.

3.10 FILTERS

- .1 During construction period, no air system to be started unless air filters function as specified. At time of building acceptance by The City, all filter banks to be in perfectly clean operating condition. There shall be no air bypass around or in filter banks.
 - .2 Install all filters as per mfg. published installation data.
-

3.11 FAN SYSTEMS - GENERAL

- .1 Use flexible connections at inlets and outlets where ductwork and plenums connect to fans and air-handling equipment.
- .2 Fan Vibration Isolation
 - .1 Fan manufacturer to submit necessary information for proper isolation selection. This information to be incorporated in shop drawings and shall include fan sizes, fan speeds, equipment weights, etc.
- .3 Fan Vibration Isolation
 - .1 Install as per Isolation manufacturer's published data.
- .4 All equipment shall be installed in strict accordance with manufacturer's published data.
- .5 Protection of Fan Equipment Before Installation
 - .1 Grease shafts, sheaves, etc. to prevent corrosion. Fan bearings to be greased or oiled at time of building takeover.
- .6 Centrifugal fans located outdoors to have drain holes in casing.
- .7 Co-ordinate installation of smoke detectors with Division 16 - Electrical.

3.12 AIR COOLED CONDENSING UNITS

- .1 Install unit as per manufacturer's published data. Provide clearance at access doors.
- .2 Provide auxiliary liquid receiver c/w shut-off relief valves if condensing unit is not adequate for storage of refrigerant during pump down periods. Receiver capacity to be total system refrigerant value plus 20% allowance for expansion. Obtain approval from Contract Administrator for receiver location and piping sizes and design.
- .3 Refrigeration manufacturer to include in quotation for services of his factory-trained technician to review installation of units, refrigerant piping and system control wiring and to submit a report to Contractor and Contract Administrator which states that condensing units have been installed, piped and wired satisfactorily.

3.13 REFRIGERANT PIPING AND ACCESSORIES

- .1 Retain services of experienced Refrigerant Subtrade to provide complete refrigeration installation. Subtrade shall be member of CRACCA. Subtrade shall submit refrigerant piping layout c/w sizing calculations to Contract Administrator for review prior to Work commencing.
 - .2 Bleed nitrogen through piping when welding to prevent oxidation of internal pipe surface. All piping to be installed in accordance with good refrigerant piping practice with minimum number of fittings to minimize friction loss. Provide separate piping or split refrigerant circuits.
 - .3 Pressure test refrigerant piping with nitrogen 2068 kPa (300 psig) for four hours.
 - .4 Suction piping to be installed to ensure oil return to compressor. Grade lines toward compressor and provide oil traps. Where specified on drawings, provide double suction risers with oil traps and inverted loop connections for all vertical lines in system.
 - .5 Provide additional amounts of oil and refrigerant required during system warranty.
 - .6 Provide horizontal and vertical piping support in accordance with accepted standards.
 - .7 Refrigeration sub-trade to provide detailed wiring diagram showing all power and control wiring related to refrigeration cycle, including refrigerant solenoid pilot control, interlocks between condensing units and supply fan, temperature control interlocks and all other control wiring for complete refrigeration system operation to approval of refrigeration equipment manufacturer and Contract Administrator. Supply all control transformers and all necessary auxiliary controls to provide complete operational system to approval of equipment manufacturer and Contract Administrator. Section 15900 shall provide single or multiple stage start/stop control contacts and interconnecting wiring only.
 - .8 Refrigeration sub-trade shall provide startup services of refrigeration system with The City's representative present. Instruct The City on proper operation of the system and equipment. Providing that equipment functions satisfactorily, Refrigeration Sub-trade shall confirm in writing date of this startup to Mechanical Trade, Contractor, The City and Contract Administrator. This letter will form part of warranty period documents.
 - .9 Refrigerant sub-trade to provide 12 month warranty on entire refrigeration system including equipment, piping and accessories, such that any further adjustments or alterations during warranty period required to achieve specified refrigeration system performance to be at no additional cost to The City. Warranty to
-

commence after date of satisfactory start-up and upon receipt of refig. manufacturer's report of the overall system. Actual date to be determined by the Contract Administrator.

- .10 Refrigeration sub-trade shall include for normal Fall shutdown services as recommended by refig. manufacturer. Include in quotation for startup during second cooling season. Issue reports for each operation to The City and Contract Administrator. Refrigeration sub-trade shall ensure that The City's representative is present during second cooling season start-up to verify that refrigerant and oil levels are satisfactory. Provide The City with 48 hour prior notice. The City shall pay for necessary refrigerant, oil and parts required providing system warranty period has terminated.

3.14 COOLING COIL (REFRIGERANT)

- .1 On built up coil banks, coils to have drain troughs to collect water from top coils and direct it to basin by means of downspouts thus preventing flooding of lowest coil. Each drain trough shall be a separate unit bolted to the coil casing, flanged for easy removal. Drain pipe to be 37mm (1 1/2") diam., trough to extend 100mm (4") out, 37mm (1 1/2") high.
- .2 Where there is not sufficient space to pull coils, coils shall be removed on downstream side of unit.

3.15 DIFFUSERS, REGISTERS AND GRILLES

- .1 Provide sponge gasket behind each outlet or inlet and adequate fastenings to prevent streaking between outlet and duct, wall or ceiling.
 - .2 Shop drawings to be accompanied by itemized list indicating unit locations by room number and unit size. Itemized list noted above shall be certified by direct representative.
 - .3 Submit typical unit c/w all accessories, specified finishes, for all diffusers, grilles and registers, if requested by Contract Administrator. Materials installed on job to be fully equal to samples submitted for approval.
 - .4 Exact dimensions of walls, etc. are as per architectural drawings. Install diffusers so they fit properly in ceiling suspension system. Co-ordinate with all related sub-trades.
 - .5 Should there be any confliction in location of grilles, registers and diffusers with lights, etc. matter to be referred tp Contract Administrator for directive. If requested by Contract Administrator , re-locate grilles, diffusers and registers and ductwork attached, within 1.2m (48") of locations noted on
-

drawings, without extra cost to The City. Refer to drawings for additional requirements.

- .6 Section 15800 to paint, with flat black finish, ductwork exposed to view through inlet or outlet grilles, registers and louvres.

3.16 ACOUSTIC DUCT INSULATION

- .1 Duct sizes are free area inside duct dimensions. Where lining is required, actual duct dimensions to be increased to allow for thickness of internal insulation.
- .2 Round Low Pressure Ducts
 - .1 Insulation adhered with No. 3M-29 or BF81.71. Breaks and joints to be painted out with BF-60-30N fire retardent mastic. Exposed edges to be coated with adhesive.
- .3 Rectangular Low Pressure Ducts
 - .1 Impale on welded studs spaced 400mm (16") o.c. Paint breaks and joints with BF-60-30N fire retardent mastic. Coat exposed edges with adhesive. Projecting fasteners and ends cut off vertically flush.

3.17 VARIABLE VOLUME VALVES

- .1 Install as per manufacturer's published data.
- .2 Sections between duct sections and valves to be joined by sheet metal screws on 200mm (8") centres, with three screws, each side of joint. After assembly, brush both joint and screws with sealing compound.
- .3 VAV manf. shall provide start up and calibration for all controls provided with equipment after installation. Submit report to Contract Administrator stating calibration has been preformed.

3.18 TESTING OF FIRE DAMPERS AND CEILING FIRE STOPS MOTORIZED SMOKE DAMPERS

- .1 Refer to Section 15990 H.V.A.C. Balance and Testing.
 - .2 Section 15800 shall repair all units that have been identified as being faulty by Section 15990.
-

3.19 CHIMNEY AND BREECHING

- .1 Provide venting systems for all fired equipment.
- .2 Breeching shall slope up to chimney and shall offer no restriction to flow. Provide long sweep elbows. On forced draft breeching provide cleanout at boiler.
- .3 The vent connector rise from each piece of equipment shall be the maximum possible to enhance flue gas venting.
- .4 Support chimneys and breeching from structure.
- .5 Connections to equipment shall be installed as recommended by the equipment manufacturer. Locate chimney minimum of 907mm (3'-0") above highest point of roof including any project and/or rooftop mounted equipment within 3m (10'-0") horizontal from chimney, unless higher chimney is noted on drawings.
- .6 Provide guy wire support as noted or as recommended by manufacturer.
- .7 Venting system diameter shown on drawings represents a minimum size only. Contractor shall provide adequately sized venting systems, including all vent connections, breeching, vents, chimneys, rain caps and other associated components, for all fuel fired equipment. Sizing of venting systems shall be determined to suit fuel fired equipment and vent system provided, and shall meet requirements of vented equipment manufacturer and vent system manufacturer. In case of a variance in requirements between the two manufacturers, the larger size shall be used. Manufacturer's sizing calculations shall be submitted to the Contract Administrator for review. Performance deficiencies related to inadequate vent sizing shall be corrected at no additional cost to The City.

3.20 CLEANING OF H.V.A.C. SYSTEMS

- .1 Ensure electrical power supply to air handling equipment, fans, etc. is locked out and tagged prior to commencement of Work. Maintain the system lockout intact and ensure the system is not-restarted or operated until Work completed.
 - .2 Segregate points where access to fan chambers, plenums, larger diameter ducting, etc. will be made from adjacent Work or Occupied Areas by closing doors, placing of barricades or tape barrers, etc.
 - .3 Provide polyethylene drop sheet beneath and adjacent to all points where access to air handling equipment, ducting, plenums, etc. will be made.
-

- .4 Provide and post required signage at all points where personnel access to air handling equipment, ducting, plenums, etc. is possible.
- .5 Seal openings in air handling equipment, ducting, plenums, diffusers, grilles, etc. using polyethylene and tape to prevent the spread of dust and to assist in the establishment of negative pressure.
- .6 Provide necessary access openings in ductwork, plenums, etc. at locations required to complete Work specified. Repair openings made following completion of Work as follows:
 - .1 Access holes smaller than 10" x 10" shall be re-sealed in an airtight manner using 24 gauge cross broken sheet metal, sheet metal screws and duct sealant.
 - .2 Supply and install specified access doors to re-seal openings greater than 12" x 12". Refer to Cl. Duct Access Doors.
- .7 Provide additional drop sheets to protect surfaces, building fabric and items remaining within the workarea and to prevent the spread of dust and debris.
- .8 Establish negative pressure within air handling equipment, ducting, plenums, etc prior to and throughout the cleaning process. Where required section of branch runs off ducting, etc. to maintain air flow.
- .9 All main and branch ducts where entry by a worker is not possible will be cleaned using an air skipper inserted into the duct at intervals not exceeding 25 ft. (7.6m).
- .10 Ensure each branch line is cleaned from each diffuser or grille, along the entire length of the duct back to the main inclusive.
- .11 Portable vacuum system may only be used on ducting with a circumference of less than 48 in.; use truck-mounted vacuum system on ducting with a larger circumference.
- .12 Coils, fan blades, etc. shall be pressure washed with a non toxic, non corrosive approved detergent germicide solution applied with a low volume, high pressure wash unit. In addition, coils will be brushed, scraped and vacuumed as necessary. Adequate care shall be taken to prevent damage to building surfaces.
- .13 Dust and film build-up shall be cleaned from all surfaces of the building's ventilation system which come into contact with the circulating air.

PART 1 - GENERAL

1.1 GENERAL

- .1 All drawings and all sections of the specifications shall apply to and form an integral part of this section.
- .2 Wherever words "shall be capable of" appear in specifications, interpret as meaning that; where feature or performance referred to is being applied, that feature or performance shall be provided. Where feature or performance is not applied now, but will be applied in future (i.e. Card Access Control), system shall be provided with all necessary central hardware and software required to support that feature or performance, with only addition of field hardware being required at that future time.

1.2 WORK INCLUDED

- .1 Labour, material, plant, tools, equipment and services necessary and reasonably incidental to completion of temp. control/instrumentation systems as noted herein and/or on the drawings.
- .2 Provide complete system of Johnson automatic controls for systems indicated.
- .3 Control equipment to be product of one manufacturer unless otherwise specified.
- .4 Prewired or prepiped controls on package equipment specified, is not included in this Section.

1.3 ELECTRICAL WIRING PERFORMED BY SECTION 15900

- .1 Supply and installation of all conduit, wire, electric relays, connections and other devices required for control circuit wiring for systems as specified in Section 15900, whether line or low voltage, shall be responsibility of Section 15900, except as noted above.
 - .2 Section 15900 shall either use own electricians, retain and pay for services of successful Division 16, or use an electrical sub-trade acceptable to Contract Administrator to supply and install all conduit and wiring for systems as specified in this Section.
 - .3 Factory trained servicemen in employ of manufacturer, shall make final wiring connections on all components, mount and electrically connect all controls.
-

- .4 Electrical wiring shall be installed in conformance with CSA, ULC, Manitoba Building Code, National Building Code of Canada 1990 and standards set in Division 16 of this specification.
- .5 Ensure that adequate conduit is installed during initial phases of construction, to accommodate total systems requirements.
- .6 Wire all safety controls in series with both 'Hand' and 'Auto' starter positions to ensure that systems are properly protected.
- .7 Section 15900 shall provide all other conduit and wiring required for Section 15900 systems operation, including tie-ins from Section 15900 supplied relays to motor starting circuits.
- .8 If approved by system manufacturer, cable up to 30 Volts may be installed in extra-low voltage communication cable tray.
- .9 Refer to Section 16150 for conduit and cable identification requirements.
- .10 Section 15900 shall provide all control circuit wiring required for DX refrigerant systems. Co-ordinate wiring with refrigerant sub-trade wiring diagrams.
- .11 Section 15900 shall provide detailed wiring diagrams for remote supervisory panels supplied with rooftop equipment, connections between Section 15900 supplied equipment and DX cooling equipment, and SCR contactor connectors for electric heating coil and re-heat coil controls.

1.4 PROTECTION OF SOFTWARE RIGHTS

- .1 Prior to the delivery of software, The City shall enter into software license agreement with provisions such as limiting use of software to equipment provided under these specifications, limiting copying, preserving confidentiality and prohibiting transfer to third party.

PART 2 - PRODUCTS

2.1 IDENTIFICATION OF EQUIPMENT - GENERAL

- .1 Use engraved black and white laminated plastic, 25mm x 62mm (1" x (2-1/2")), at all thermostats, thermometers, panels, etc., supplied so as to clearly indicate service of particular device. Does not apply to room thermostats. Manual switches, unless they come with standard nameplates, and thermostats, thermometers, switches, etc., installed on local panels to be similarly labelled. All controllers, relays, etc. mounted inside local panels may have tape labels.
-

- .2 Excluding room thermostats, convector valves, ceiling reheat and radiant panel valves and damper assemblies, provide lamacoid identification plates fastened with rivets or self-tapping screws at all equipment supplied by Section 15900 so as to clearly indicate service of particular device. All manual switches, unless they come with standard nameplates, shall be similarly labelled.
- .3 Equipment installed on surfaces of local panels shall be similarly labelled. Equipment mounted inside local panels, must have permanent plate labels with self-tapping screws. Tape labels are not acceptable.
- .4 Identification plates, by Section 15900, to be white background with minimum 5mm high black letters, unless specified otherwise. Electrical systems identification to be as per Section 16150.
- .5 Information on lamacoid identification plates to be consistent with 'as-built' control drawings.
- .6 Prior to lamacoid fabrication, submit copies of control drawings and complete list of proposed wording for each lamacoid, for approval by Contract Administrator and The City. Include copy of approved lamacoid list in each Maintenance/Operating Manual.

2.2 VALVE ACCESS IDENTIFICATION

- .1 Points of access to radiant panel and reheat coil control valves shall be identified with black lamacoid with 10mm high white lettering mechanically fastened either onto ceiling T-bar grid or onto access door.
- .2 Lamacoids shall state:
 - .1 "RAD. HTG. PANEL"
 - .2 "HTG. COIL HC- (STATE NO.)"

2.3 INSTRUMENT CABINETS

- .1 Provide at each system or groups of systems, cabinet type metal control panel with all instruments mounted inside locking cover. All panels shall have same key. Temperature indication and control point adjustments and gauges labelled as to function with lamacoid nametags fixed to panel face with self-tapping screws. All electrical equipment mounted in cabinet to be pre-wired to labelled terminal strips.
-

2.4 CONTROL DAMPERS

- .1 Provide all control dampers of type and sizes indicated. All outside, exhaust and relief control dampers to be opposed blade low leakage moduflo dampers. Frames to be heavy ga. galv. steel formed for extra strength with mounting holes for flange and enclosed duct mounting. Dampers available in 50mm (2") size increments from 203mm (8") horizontal and vertical to 1219mm (48"). Requirements over 1219mm (48") to be standard modules with interconnecting hardware. 1.6mm (16 ga.) damper blades, galv. steel, roll formed for high velocity performance. Blades of 203mm (8") width maximum; blade seals and spring loaded stainless side seals. Dampers and seals suitable for temperature ranges of -40 deg.C to 100 deg.C. Leakage shall not exceed 1% with approach velocity of 7.62M/s (1500fpm) when damper is closed against 100mm (4") W.G.

2.5 VALVE & DAMPER OPERATORS

- .1 Electric:
 - .1 Electric proportional or two position type as required, with adjustable forward and return stops, aluminum housing and spring return.
 - .2 Operators mounted outside shall be c/w internal heater.
 - .3 Valve operators shall be of type to withstand temps. likely to be encountered in application.
- .2 Size operators to guarantee component operation under maximum load. No damper operator shall be required to drive more than 2.5 sq.m. (27 sq.ft) of damper.
- .3 Refer also to Cl. "Variable Volume Valves" in Section 15800 for further requirements.

2.6 LOW TEMPERATURE CUTOUTS

- .1 Provide on coils or where noted, low temperature cutouts with 6096mm (20 ft.) temperature sensitive elements wound across downstream face of coil.
 - .2 All air systems introducing O.A. shall have air side low temperature cut-out switch. If system does not have steam or water coil ahead of supply fan, safety control can be located on leaving side of fan.
 - .3 Cut-outs must have manual reset unless noted otherwise.
 - .4
 - .1 In heating season, below 5 deg C O.A. as sensed by O.A. thermostat on water coil systems provide:
 - .1 Aquastat set at 21 deg.C in supply water to coil to alarm on low temperature and shut off fan.
-

- .2 Provide pilot light indications on local panel.
- .3 Current sensing relay on circulation pump to shut down fan and activate alarm.

2.7 ROOM THERMOSTAT

- .1 Proportional or snap action contact type to suit application. Provide with setpoint indicator thermometer and adjustable stops. Direct or reverse acting to suit system. Setpoint range adjustable from 16 deg C to 32 deg C.
- .2 Provide blank covers with concealed adjustment and thermometers inside cover. Private offices to have exposed thermometer and adjustment.
- .3 Provide heavy duty plastic guard on thermostats in public areas such as entranceways, washrooms, corridors, gymnasiums and other unsupervised areas.

2.8 MISCELLANEOUS DEVICES

- .1 Provide necessary relays, cumulators, three-way air valves, positioners, pneumatic electric switches, three-way solenoid valves, two-way and three-way air switches, clocks, transformers, etc. to make complete and operable system.
- .2 Install on local panels, unless noted otherwise.

2.9 ALARM MODULE SEQUENCE

- .1 Where reference is made to alarm annunciation in any operation sequences, provide equipment to accomplish following sequence for each point annunciated.
 - .1 Alarm condition - audible ON, corresponding visual point flashing.
 - .2 Acknowledge - audible OFF, visual ON steady.
 - .3 Normal - audible OFF, visual OFF.
 - .4 Test - audible ON, visual ON steady - all lights.
- .2 Each subsequent alarm condition shall cause repeated sequence as detailed above whether or not previous alarm condition has been acknowledged.

2.10 RESET TIMERS

- .1 Driven by timing motor connected to independent circuit from load being controlled. Motor shall be suitable for operation on 120V AC, 60 Hz. power.
-

- .2 Timer shall have 0 - 6 hour range c/w 6 min. graduations on dial face. Timer shall have 'hold' position eliminated.
- .3 Contacts shall be S.P.D.T. rated at 120 Volts, 10 Amps, c/w independent N.O. connection for timer motor.
- .4 Timers shall be suitable for panel or surface mounting to suit application.

2.11 IDENTIFICATION OF DATA GATHERING & D.D.C.PANELS

- .1 Provide lamacoid nameplates to identify following:
 - .1 Data Gathering Panel Title.
 - .2 Supply feeder panelboard number, circuit number, and panelboard location.
- .2 Fasten nameplates with rivets or self-tapping screws to exterior of Data Gathering Panel door.
- .3 Refer to subsection "Identification of Equipment - General", and comply with all requirements related to lamacoid nameplates.
- .4 For each panel or terminal cabinet, indicate designation, system, load and area served. Provide directories to identify all termination points. For each termination point, identify equipment connected, equipment location and termination wire colour code or identification code number. Insert copy of directory in clear plastic pouch attached inside panel or terminal cabinet door, and insert copy into each Maintenance/Operating Manual. All wires or cable shall be colour coded and/or identified with identification code using wire markers. Information on data cards or directories shall be either typewritten or neatly printed with permanent ink.

2.12 DIRECT DIGITAL CONTROL SYSTEM

- .1 Control system shall be direct digital control (D.D.C.) system which can, without additional equipment, perform all automatic temperature control and energy management functions as required in this specification. D.D.C. shall be defined as control technique through which process variable is continuously monitored by digital computer which accomplishes loop control by calculating control solution and provides, through transducers, pneumatic output to control device.
 - .2 Building control system shall consist of independent, stand-alone control units. Each DDC unit shall be capable of performing all specified control functions in completely independent manner. All operator communication with system shall be via operator terminals provided for each DDC control unit.
-

- .3 Each DDC unit shall contain necessary equipment for direct interface to sensors and actuators associated with it.
 - .4 Control strategies shall be definable at each control unit utilizing operator terminal.
 - .5 Each DDC unit shall include microcomputer controller, power supply, input/output modules, termination modules, and self-charging battery capable of supporting all memory within unit if commercial power to unit is interrupted or lost for minimum of eight (8) hours. Upon resumption of power, control unit shall resume full operation without operator intervention. Unit shall automatically reset its clock such that proper operation of timed sequences resumes without need for manual reset of clock.
 - .6 DDC unit shall be capable of direct interface to following industry standard sensors and input devices:
 - .1 Analog Inputs:
 - .1 4-20 mA
 - .2 0-10 V DC
 - .3 thermistors
 - .4 3-15 psi
 - .2 Digital inputs:
 - .1 dry contact closure
 - .2 pulse accumulator
 - .7 DDC controller unit shall be capable of following control outputs:
 - .1 Digital outputs (contact closure)
 - .1 Motor starters
 - .2 Analog outputs
 - .1 3-15 psi
 - .2 4-20 mA
 - .3 0-16 V DC
 - .8 Temperature control functions shall be executed within DDC unit. Loop control shall be executed via DDC algorithms. User shall be able to customize control strategies, sequences of control, and shall be able to define appropriate control loop algorithms and choose optimum loop parameters for loop control. Control loops shall support following control modes:
 - .1 Two position (on-off, slow-fast, etc.)
 - .2 Proportional (P)
 - .3 Proportional plus integral (PI)
 - .4 Proportional, integral, plus derivative (PID)
 - .9 It shall be possible to create, modify or remove control algorithms within unit while it is operating and performing other control functions. Input for these changes shall be made directly into DDC unit. Each control loop shall be user definable in terms of:
 - .1 Sensors/actuators that are part of control strategy
 - .2 Control mode
-

- .3 Gain
 - .4 Control action
 - .5 Sampling time

 - .10 DDC unit shall be capable of performing following energy management routines as a minimum:
 - .1 Time of day scheduling
 - .2 Start/stop time optimization
 - .3 Peak demand limiting
 - .4 Duty cycling (temp. compensated)
 - .5 Economizer control
 - .6 Enthalpy changeover
 - .7 Supply air reset
 - .8 Chilled water reset
 - .9 Economizer control
 - .10 Outdoor air reset
 - .11 Event initiated programs

 - .11 In addition, The City shall be able to create customized control strategies based upon arithmetic, Boolean or time delay logic. Arithmetic functions shall permit simple relationships between variables (i.e. +,-,--,X) as well as more complex relationships (i.e. square root, exponential).

 - .12 System shall permit generation of control strategies activated in any of the following ways:
 - .1 Continuously
 - .2 At particular time-of-day
 - .3 On pre-defined rate
 - .4 When specific measured or controlled variable reads selected value or state.
 - .5 When a piece of equipment has run for certain period of time.

 - .13
 - .1 Unit shall permit full operator communication including:
 - .1 Obtaining information about system performance;
 - .2 allowing operator to change system operation;
 - .3 diagnosing system malfunctions
 - .2 Operator communication shall be through any one of following operator terminals:
 - .1 Panel mounted terminal
 - .2 Hand-held terminal
 - .3 Black and white CRT
 - .4 Communicate with existing SCU network.

 - .14 All temp. control strategies and energy management routines shall be definable by operator through operator's terminal. It shall be possible for operator to modify system functions independently after receiving training previously specified. Provide all equipment and documentation necessary to allow trained operator to independently perform following functions:
 - .1 Read value of measured variable (i.e. temp.)
 - .2 Start or stop equipment.
-

- .3 Monitor status of equipment being controlled.
- .4 Read set point of control loop.
- .5 Determine control strategies that have been defined for specific piece of equipment.
- .6 Generate displays of control strategies.
- .7 Add/delete control loops to system.
- .8 Add/delete points to system.
- .9 Create, modify or delete control strategies.
- .10 Assign sensors and/or actuators to a control strategy.
- .11 Tune control loops through adjustment of control loop parameters.
- .12 Enable or disable control strategies.
- .13 Generate hardcopy records of control strategies on printer.
- .14 Select points to be alarmable and define alarm state(s).

- .15 Unit shall contain self diagnostics that continuously monitor proper operation. Malfunction of unit shall be reported, and shall inform operator of nature of malfunction.

- .16 Unit shall allow on-line diagnosis via telephone modem from remote location.

2.13 DIRECT DIGITAL CONTROL SYSTEM - SOFTWARE

- .1 Provide all software necessary to maintain control of and monitor all points physically connected to stand-alone panels.

 - .2 Supply each stand-alone panel with following software:
 - .1 Real time operating system resident in ROM.
 - .2 Operator/system communication software.
 - .3 Point data-base
 - .4 Report software.
 - .5 Alarm and monitoring software.
 - .6 User programming software.
 - .7 Energy management control software.
 - .8 Direct digital control software.

 - .3 Control language shall be realtime control language oriented to HVAC systems. Structure control language along conventional control loop logic to ensure ease of customer programming by building operator. All control loops shall be fully addressable from operator station(s).

 - .4 It shall be possible for operator to modify system functions independently and to independently perform functions listed below:
 - .1 Read value of measured variable
 - .2 Start or stop equipment
 - .3 Monitor status of equipment being controlled
 - .4 Read the setpoint of controlled loop
 - .5 Determine control strategies that have been defined for specified piece of equipment.
 - .6 Generate displays of control strategies.
-

- .7 Add/delete control loops to system.
 - .8 Add/delete real and virtual points to system.
 - .9 Create, modify or delete control strategies.
 - .10 Assign sensors and/or actuators to a control strategy.
 - .11 Tune control loops through adjustment of control loop parameters.
 - .12 Software enable or disable control strategies.
 - .13 Select points to be alarmable and define alarm state(s).
- .5 In addition, The City shall be able to create customized control strategies. Arithmetic functions shall permit simple relationships between variables (i.e. +, -, -, x) as well as more complex relationships (i.e. square root, exponential).
- .6 All points in all stand-alone control units shall be capable of performing following energy management routines as a minimum:
- .1 Time of day scheduling
 - .2 Start/stop optimization
 - .3 Outdoor air reset
 - .4 night setback
 - .5 Economizer changeover
 - .6 Peak demand limiting
 - .7 Duty cycling
 - .8 Supply air reset
 - .9 Economizer
 - .10 Event initiated/excepted programming.
- .7 Provide instructive menu-driven prompting software to aid operator in inputting and editing.
- .8 All energy management and operator/system control software shall be ROM resident, unless otherwise approved in writing by Contract Administrator and The City prior to bid opportunity closing.
- .9 Shall permit operator selection and designation of EMS control routines to any I/O point, and in any operator selected sequence of point priority.
- .10 All I/O real and virtual points shall be operator programmable to permit inter-point control by exception.
- .11 Shall have minimum of 3 discrete levels of secured user access, as follows:
- .1 1st - read only
 - .2 2nd - user programming of control and alarm parameters only
 - .3 3rd - system design, programming of control logic
- .12 Shall annunciate alarms (both real-time, and 48 hour summary log) noting: Point number, point description, date and time of occurrence.
- .13 Shall provide following operator initiated summary reports:
-

- .1 Current Status, including:
 - .1 Point number
 - .2 Point description
 - .3 Current date
 - .4 Current time
 - .5 Point programmed status (i.e. on/off)
 - .6 Point actual status (i.e. where real input signal is provided)
 - .2 48 Hour alarm Summary, including:
 - .1 Point number
 - .2 Point description
 - .3 Occurrence date
 - .4 Occurrence/measurement time
 - .3 24 Hour Event Summary, including:
 - .1 Point number
 - .2 Point description
 - .3 Date(s), (sliding window)
 - .4 Occurrence/measurement time
 - .5 Point data (peak value, cumulative total, etc. as relevant to the I/O function)
 - .4 30 Day Event Summary, including:
 - .1 Point number
 - .2 Point description
 - .3 Date(s), (sliding window)
 - .4 Occurrence/measurement time
 - .5 Point data (peak value, cumulative total, etc. as relevant to the I/O function)
 - .14 Shall have ability to have control algorithms created, entered, modified, down-loaded, or erased by either local or remote (i.e. through RS232C telecommunications data port) operator station without interrupting real control of other control functions. Supply an auto-selection device to automatically select which port shall communicate with master control panel, either remote dial-up or local interface (i.e. on first-come first-service basis).
 - .15 Shall perform time-interval, failure-event, and operator initiated self diagnostic assessments of all: Discrete components, circuit boards, internal connections, firmware/software and real-world input signals. Unit shall provide both real-time (selectable to operator interface, printer, or connected dial-up telephone modem) and data-logged failure annunciation/reports, detailing cause and data/time failure.
 - .16 Shall permit operator initiated software downloading/uploading to and from both a local or remote (via telephone modem interface) mass storage device.
 - .17 EMCS shall automatically disconnect dormant (i.e. inactive I/O greater than 5 minutes) local and remote operator stations, thereby opening the opportunity for communications with other operators.
-

2.14 DDC SOFTWARE APPLICATION - GENERAL

- .1 Implement following control strategies and techniques within DDC software developed for all systems controlled by DDC controllers. Control set-points shall be as described in individual system sequences of operation specified in this section. Where local indication manual adjustments are specified, they shall be obtained and/or adjusted utilizing operator's terminal specified in clause 'Direct Digital Control System'.
- .2 Mixed air temperature control - O.A., return air and relief air dampers shall modulate to maintain mixed air temperature. Mixed air temperature control shall interact with minimum O.A. control and system shall interact with minimum O.A. control and system shall revert to min. O.A. on signal from dry bulb, enthalpy or other economizer control as specified in individual sequences of operation in this section.
- .3 Minimum O.A. control (constant volume systems) - calculate per cent of O.A. actually provided by utilizing O.A., return air and mixed air temperatures. Override mixed air control sequence if necessary to ensure min. O.A. is maintained. If S.A. temperature falls more than 2 deg.C (4 deg.F) below setpoint min. O.A. shall be reduced to provide largest min. O.A. possible while S.A. temperature is maintained.
- .4 Ramp functions - where control loops are subject to rapid load changes (i.e. supply fan volume control on system start-up, O.A. damper control on system start-up, mixed air and discharge air temperature control when systems are manually switched to 100% O.A. mode of operation, etc.). Ramp functions shall be implemented to prevent system overshoot, cycling and nuisance tripping of low limit protection devices.
- .5 Reset Schedules - Where control loops have reset schedules associated with them, (i.e. hot water supply temperature reset based on O.A. temperature) high and low temperature alarm indication shall also be on sliding schedule. e.g. If alarm limits are set at +/- 2 deg.C from setpoint, alarm will be generated only if the sensed temperature is above or below present set point by 2 deg.C (i.e. if present, set point is 85 deg.C then alarm limits are 83 deg.C and 87 deg.C). Indication available to operator shall include, low end point of reset schedule, high end point of reset schedule, present setpoint, present high and low alarm limits and sensed temperatures.

2.15 MISCELLANEOUS DDC MONITORING

- .1 Provide all sensors, wiring, conduit, connect equipment monitoring points, described herein, to the nearest DDC panel specified in this Section.
-

- .2 Provide one binary input for sump pit high water level alarm. High water alarm contacts shall be provided by Section 15900.

2.16 FAN SYSTEM CONTROLS - GENERAL

- .1 Following control sequences shall apply to all supply fan systems whether specifically noted in sequence of operation or not.
 - .2 Where fan systems have outdoor and return air dampers modulated to maintain mixed air, discharge air, or room temperature, provide adjustable (0 - 1 min.) restriction feature to retard opening of O.A. damper on system start up and enable heating source controls to come into control and prevent nuisance tripping of low limit protection controls.
 - .3 Provide interlocks to ensure system controls energize and associated return and/or exhaust fans run when supply fan runs.
 - .4 Provide interlocks to ensure auxiliary equipment such as humidifiers, humidifier valves, outdoor air dampers, relief air dampers, etc. are shut off and/or closed when supply fan is off.
 - .5 Provide all fan systems that introduce O.A. with low limit control in discharge air to shut down supply fan and activate local alarm when discharge air temperature drops below 3 deg.C(37 deg.F). Locate low limit in manner that shall protect heating and cooling coils, and at same time not be subject to nuisance tripping.
 - .6 Provide all fan systems that introduce O.A. with adjustable O.A. damper minimum position controls. Where O.A. dampers are larger than 1 sq. m (10 Sq. ft.), dampers shall be split into two sections horizontally. Each section shall be driven by separate operator and lower section shall close when O.A. temp. falls below 0 deg.C (32 deg.F). Minimum O.A. controls shall override this requirement and modulate lower section open to maintain minimum O.A. quantity specified.
 - .7 Where relief air dampers are not directly ducted to supply/return fans, provide backdraft temp. controller to prevent backdraft condition from occurring.
 - .8 Provide differential pressure switches across each filter bank to energize "filter dirty" pilot light and sound local alarm.
 - .9 Where direct expansion cooling systems are utilized this section shall provide all necessary devices to ensure proper interface. Refer also to Section 15800.
-

2.17 SUPPLY SYSTEM AIR CONTROL

- .1 System shall operate on day/night basis as dictated by 7-day time clock.
 - .2 When supply fan runs, return fan shall run and controls shall energize.
 - .3 Mixed air control shall modulate O.A., return and relief air dampers in sequence to maintain mixed air temp.
 - .4 Discharge air control shall modulate heating and cycle DX cooling in sequence to maintain discharge air temperature.
 - .5 Provide mixed air low limit to override control of O.A. damper and prevent mixed air temp. from dropping below 13 deg.C.
 - .6 Economizer control shall revert O.A. damper to minimum position when O.A. temp. rises above 15.5 deg.C O.A. temp. exceeds return air temp., O.A. enthalpy exceeds return air enthalpy.
 - .7 Static pressure control, sensing static pressure in supply air duct furthest from supply fan, shall modulate fan capacity damper, to maintain supply air duct static pressure.
 - .8 Static pressure control, sensing return air duct static pressure at return fan inlet, shall modulate fan capacity controller, to maintain return air duct static pressure.
 - .9 When cooling is required, control of discharge air temp. shall be released to condensing units integral control system. Provide P-E switch with individually adjustable pull-in, pull-out setpoints to prevent cycling between controllers. Provide low ambient lockout stat to prevent condensing unit operation below 13 deg.C O.A. temp. Refer to Clause 'Split System Air Conditioning Auxiliary Controls' for further requirements.
 - .10 Provide adjustable minimum O.A. damper position controls.
 - .11 Provide low limit control in discharge air to shut down supply fan and sound local alarm when discharge air temp. drops below 3 deg.C.
 - .12 Provide low limit control at relief air damper to prevent backdraft condition.
 - .13 Control outside air amount by CO2 sensor in return air duct to match ventilation ratio for occupancy loads. Mixed air low limit shall be set for +6 deg. C.
 - .14 Provide local control panel with following mounted on panel face:
-

- .1 Indication:
 - .1 O.A. temp.
 - .2 Return air temp.
 - .3 Mixed air temp.
 - .4 Discharge air temp.
 - .5 Discharge air static pressure
 - .6 Return air static pressure
 - .7 Day/Night operation
- .2 Manual setpoint adjustments:
 - .1 Mixed air temp.
 - .2 Discharge air temp.
 - .3 Discharge air static pressure
 - .4 O.A. damper minimum position.

2.18 GYM SUPPLY SYSTEM

- .1 System shall operate on day/night basis as dictated by 7-day time clock.
 - .2 When supply fan runs, controls shall energize.
 - .3 Mixed air control shall modulate O.A., return and relief air dampers in sequence to maintain mixed air temp.
 - .4 Discharge air control shall modulate O.A., return and relief air dampers, heating controller in sequence to maintain discharge air temperature.
 - .5 Provide mixed air low limit to override control of O.A. damper and prevent mixed air temp. from dropping below 13 deg.C.
 - .6 Economizer control shall revert O.A. damper to minimum position when O.A. temp. rises above 15.5 deg.C, O.A. temp. exceeds return air temp.
 - .7 Provide adjustable minimum O.A. damper position controls.
 - .8 Provide low limit control in discharge air to shut down supply fan and sound local alarm when discharge air temp. drops below 3 deg.C.
 - .9 Provide low limit control at relief air damper to prevent backdraft condition.
 - .10 Provide reset timer to override 7-day time clock to allow manual switchover to day mode of operation.
 - .11 Provide night stat and P.E. switch to cycle supply system during night mode of operation. When fan runs at night O.A. damper shall remain closed and heating coil shall be full on.
-

- .12 Provide local control panel with following mounted on panel face:
 - .1 Indication:
 - .1 O.A. temp.
 - .2 Return air temp.
 - .3 Mixed air temp.
 - .4 Discharge air temp.
 - .5 Day/Night operation
 - .2 Manual setpoint adjustments:
 - .1 Mixed air temp.
 - .2 Discharge air temp.
 - .3 O.A. damper minimum position.
 - .4 Day/Night reset timer.

2.19 SUPPLY AIR SYSTEM CONTROL

- .1 System shall be under control of DDC controller with input and output connections as follows:
 - .1 Analog Inputs
 - .1 O.A. temp.
 - .2 O.A. R.H.
 - .3 Return air temp.
 - .4 Return air R.H.
 - .5 Return air S.P.
 - .6 Return air Vel. P.
 - .7 Space S.P.
 - .8 Relief air temp.
 - .9 M.A. temp.
 - .10 Discharge air temp.
 - .11 Discharge air R.H.
 - .12 Discharge air static pressure
 - .13 Discharge air velocity pressure
 - .14 S.A. duct static pressure.
 - .2 Analog Outputs
 - .1 Mixing dampers
 - .2 Relief air damper
 - .3 Heating coil valve
 - .4 Cooling coil valve
 - .3 Binary Inputs
 - .1 Filter status (pre and/or final)
 - .2 Supply fan status
 - .3 Discharge air low limit status.
 - .4 Binary Outputs
 - .1 Supply fan start/stop

2.20 GAS FIRED MAKE-UP UNIT CONTROLS

- .1 Mount and connect where shown on drawings, remote supervisory panel supplied by Section 15600.
 - .2 Refer also to Section 15600 and review controls supplied by Section 15600. Provide all necessary interlocks, relays, flow
-

switches, and any other devices required to provide proper sequence of operations as described in this section.

- .3 Mount and connect remote supervisory panel in strict accordance to manufacturer's published data.

2.21 SUMP PUMP CONTROLS

- .1 Provide float controls and high water alarm to operate two pump motors of duplex pump installation as follows:
 - .1 Automatically alternate first pump to start on each successive operation.
 - .2 Automatically start second pump should first pump fail, or to provide additional capacity when load becomes too great for first pump.
 - .3 Automatically provide high level alarm should liquid level rise above predetermined level setting.
- .2 Provide three PIL floating pump switches, control and alarm panel, etc.
- .3 Control panel shall include all necessary relays, relay bases, terminal blocks, wiring, pilot lights, alarm buzzer, test and silence pushbuttons, etc. required to provide previously described pump operation. Provide unpowered, N.O., contacts for pump control and energizing remote alarm horn, supplied and installed by Div. 16. Contact shall be rated for 120 Volt, 10 Amp. service.
- .4 Mount control and alarm panel where shown on drawings.
- .5 Connect remote alarm contact to DDC/CCMS.

2.22 SHOP DRAWINGS

- .1 Include following with submission:
 - .1 Conventional control drawings showing pneumatics, electrics, bill or materials, etc.
 - .2 List of alarm set point parameters, DCP Point Data Definition (CDPC), Define Controller Points (XLPT), and Define Controller Alarm Points (XALM).
 - .3 Sketch of all graphics.
 - .4 Flow chart of RACL programs.
 - .5 Updated C.C.M.S. transmission loop drawings.
 - .6 Fabrication details and proposed wording for all lamacoid identification.
 - .2 Prior to commissioning, submit as-built information and drawings for each of above items, for use by The City during commissioning.
-

PART 3 - EXECUTION

3.1 GENERAL

- .1 Control components and interconnecting tubing systems to be installed by trained control mechanics, regularly employed by Section 15900.

3.2 OPERATING INSTRUCTIONS AND AS-BUILT INFORMATION

- .1 Provide operating instructions as specified elsewhere. Include schematic drawings of all control systems including control sequence write-up.
 - .2 Provide six hard cover copies of complete information pertaining to temperature control\instrumentation system for The City's permanent record. This to include following:
 - .1 As-built schematic control diagrams with complete control sequence write-up.
 - .2 Operator's manual including maintenance instructions.
 - .3 Contract Administrator's data and data product sheets.
 - .4 Parts list of all components including repair instructions.
 - .5 Suggested spare parts list.
 - .3
 - .1 Provide one set of reproducible control diagrams noted in
 - .2 .1 above on "DILAR FILM" (mylar), blackline (dry eraseable), reverse reading (reverse print).
 - .3 Also provide one set of updated as-built C.C.M.S. transmission loop drawings on mylar film.
 - .4 In addition, each mechanical room shall have respective control diagrams, control sequence and equipment model numbers mounted permanently on heat laminated plastic encased prints with grommet hangers. Mount adjacent to equipment or as recommended by The City.
 - .5 During system commissioning and at such time acceptable performance of Temperature Control System has been established, provide on-site operator instruction to The City's operating personnel. Operator instruction during normal working hours will be performed by competent Section 15900 representatives familiar with systems specified. At time mutually agreed upon as stated above, provide instruction to The City's designated personnel on operation of all temperature control equipment and systems and describe its intended use with respect to programmed functions to the overall operational program equipment functions.
 - .6 Provide in DDC operator's manual, details of all functions, operator interaction with the system, complete with examples. Manual shall be written by professional technical writers.
-

Provide operator's pocket guides for quick reference on day-to-day routine operations.

3.3 SERVICE AND WARRANTY

- .1 Upon completion of installation, all thermostats, control valves & all other equipment shall be adjusted as required to place system in complete operating condition subject to Contract Administrator's approval. Make all adjustments in collaboration with field Contract Administrator responsible for balancing air and water system.
- .2 If within one year from date of completion as interpreted by Contract Administrator, any of equipment herein described is proven to be defective in workmanship or materials, it shall be replaced or repaired free of charge to The City.
- .3 After installation completion, provide any service incidental to proper performance of control system under guarantees outlined above for guarantee period. Normal maintenance of system or adjustment of components is not to be considered part of guarantee.
- .4 Provide two additional service inspections, one prior to change of system; i.e. heating to cooling (Spring) or cooling to heating (Fall). Provide The City with three days prior notice before inspection is to take place so The City can arrange to have his representative present during full inspection. Following each inspection an itemized report shall be forwarded to The City. Inspections shall include calibration of controllers and sequencing and lubrication of all dampers, damper operators and valves, trip testing of high and low limit protection devices.

3.4 INSTRUMENT MOUNTING

- .1 Mount transmitters and sensing elements on pipework at location where temperature is to be sensed. Care shall be taken to prevent breaking of insulation barrier and where practicable instruments shall be stood off on sheet metal brackets to allow installation of insulation behind instrument.

3.5 LOW TEMPERATURE CUTOUTS

- .1 Wire into "HAND" and "AUTO" positions of fan starter switch circuits, or if there is none, wire into local fan circuit such that, when any 305mm (12") section of element senses temperature below +2 deg. C, supply fan to de-energize and O.A. dampers to close.
-

3.6 ROOM THERMOSTATS

- .1 Room thermostats and sensors shall be located where shown on drawings. Mount thermostats and sensors approximately 1400mm (56") above finished floor.
- .2 Calibrate all thermostats and confirm to The City that this Work has been done.

3.7 TIME CLOCKS

- .1 Since time clock locations are critical to building operation, their location must be approved by Contract Administrator. They may be located remote from system equipment.
- .2 Locate time clock as noted on drawings, and/or as directed by Contract Administrator.

3.8 RESET TIMERS

- .1 Location of reset timers shall be approved by Contract Administrator prior to installation.
- .2 Reset timers may be mounted remote from system equipment being controlled.

1.1 GENERAL

- .1 All drawings and all sections of the specifications shall apply to and form an integral part of this section.
- .2 Testing, Adjusting and Balancing (TAB) Agency shall be an experienced, independent Contractor specializing in the testing, adjusting and balancing of HVAC systems.
- .3 Include extended service for 90 days after completion of final balancing Work, during which time Contract Administrator at his discretion may request re-check or re-setting of any systems and/or equipment listed in test report

1.2 SCOPE OF WORK

- .1 Provide complete testing, adjustment and final balancing of all building air systems.
- .2 Provide inspection, verification and testing of all fire dampers, fire/smoke dampers, smoke control dampers and ceiling fire stops after installation. Coordinate the Work with Sections 15800 and 15900.

PART 2 - PRODUCTS

2.1 BALANCING REPORTS

- .1 Provide two copies of detailed draft balancing report to Contract Administrator for review after completion of all adjustments.
- .2 Final balancing report shall incorporate all changes resulting from Contract Administrator's comments and any adjustments undertaken since the draft report was issued.
- .3 Provide four copies of final balancing report.
- .4 Provide sufficient number of copies of final balancing report to Mechanical Subtrade for inclusion in Operating & Maintenance Manuals.

2.2 FIRE PROTECTION EQUIPMENT VERIFICATION REPORTS

- .1 Provide detailed verification report to include all fire protection devices noted herein. Report shall list each device and verification of its operation and installation per the requirements specified herein.
-

- .2 Provide two copies of completed draft verification report to Contract Administrator for review.
- .3 Incorporate comments or changes requested by Contract Administrator and provide sufficient number of copies of final report to Mechanical Subtrade for inclusion in Operating & Maintenance Manuals

PART 3 - EXECUTION

3.1 GENERAL

- .1 All instruments used shall be accurately calibrated and maintained in good working order. If requested, tests shall be conducted in the presence of Contract Administrator and/or his representative.
- .2 Schedule all Work to comply with completion date.
- .3 Work shall not begin until system has been completed and in full working order. Division 15 shall put all heating, ventilating, and air-conditioning systems and equipment into full operation, as season would demand, and shall continue operation of same during each working day of testing, adjusting and balancing.

3.2 AIR BALANCING

- .1 Coordinate with Sections 15600 and 15800 to ensure installation of all manual adjusting dampers and pitot tube enclosures are as indicated, as specified and as required to allow proper adjustment of air systems.
 - .2 Sections 15600 and 15800 to provide initial alignment and tension of all fan pulleys and belts supplied by them.
 - .3 Testing Procedure:
 - .1 Test, adjust and record all fan speeds, motor amperes.
 - .2 Make pitot tube traverse to main supply and obtain cfm at fan.
 - .3 Test and record static pressure for each system at fan suction and discharge.
 - .4 Adjust all supply and return air ducts to proper design cfm.
 - .5 Test and adjust each diffuser, grille, and register to within 5% of design requirements. Balance as per manufacturer's recommendations.
 - .6 All outlets shall be adjusted to provide proper throw and distribution, in accordance with architectural requirements.
 - .7 Fan operating conditions tested shall confirm air delivery within 5% of manufacturer's fan curves.
-

.8 Systems shall be balanced so that fans operate at lowest possible static pressure.

.9 Prepare single line diagrams of duct systems indicating terminal outlets identified by number. List on data sheets all such outlets denoted by the same numbers, including the outlet sizes, 'K' factor, location, cubic feet per minute and jet velocity. Provide this data for all supply, return and exhaust air systems.

- .4 As part of Work of this Contract, Sections 15600 and 15800 shall make any changes in the pulleys and belts, and any additional manual dampers for correct balance as recommended by Section 15990, at no additional cost to The City. Section 15990 shall provide final alignment and tension adjustment of fan pulleys and belts.

3.3 SYSTEM CHECK

- .1 Provide spot checks of systems if called upon by Contract Administrator. If capacities, fan speeds, ratings, etc. do not agree with submitted balance report, rebalance system or systems in question, until satisfactory results are received.

3.4 TESTING/VERIFICATION OF FIRE PROTECTION EQUIPMENT

- .1 Section 15990 shall test and verify operation all new and/or relocated fire dampers, combination fire/smoke dampers, ceiling fire stops and smoke control dampers on this project. Co-ordinate Work with Sections 15800 and 15900.
- .2 Testing shall be performed after air balancing has been completed.
- .3 Test shall include following:
- .1 Visual inspection of each device:
 - .1 Confirm appropriately rated device installed and CSA/ULC label affixed and visible through duct/ceiling access door.
 - .2 Confirm appropriate duct and/or ceiling access door provided to permit servicing of device. Confirm duct access door openable without interference from adjacent ceiling, pipes, ducts, etc.
 - .3 Confirm device has been installed in accordance with requirements of the specifications, manufacturer's instructions and codes.
 - .4 Confirm proper installation, clearances, use of proper angle framing, use of proper fasteners, use of fire rated material in wall opening, location of breakaway joints etc.
 - .5 Confirm that device has not been painted.
 - .2 Operational inspection of each device to include:
 - .1 Manual release of fusible link allowing device to close. Confirm tight fit closure without binding.
-

- .2 Confirm that appropriate fusible link is installed.
- .3 Re-open device and reset fusible link connection.
- .3 Following requirements are in addition to the above noted testing requirements and shall apply to all motorized smoke and fire/smoke dampers, including all motorized dampers associated with smoke control systems:
 - .1 Associated fan system shall be operating as per normal conditions.
 - .2 Power to operator shall be applied/removed, as required, to cause damper to open. Ensure full opening operation without binding or overdriving of operator.
 - .3 Power to operator shall be removed/restored, as opening operation without binding or overdriving of operator.
 - .4 Ensure damper closes/opens against associated fan operating static pressure.
 - .5 Ensure proper adjustment of all damper drive linkages for fully open and fully closed positions and operation through full range without binding.
 - .6 Ensure proper device configuration e.g. power-to-open or power-to-close as specified.
- .4 Co-ordinate Work with Sections 15800 and 15900. Instruct Sections 15800 and 15900 as appropriate to repair or replace, as required, all devices or components of devices identified as being faulty, and to correct any installation deficiencies noted.
- .5 After necessary repairs have been completed, Section 15990 shall reinspect/retest each device as indicated above.
- .6 Provide verification report on completion of Work. Report shall indicate general location (e.g. room number or description) and specific location (e.g. north wall above ceiling) of access door to device. Report shall include itemized verification of following, as appropriate, for each device:
 - .1 Device is fully accessible.
 - .2 Device has been properly installed
 - .3 Device has been successfully tested.
 - .4 Device has been reset.
 - .5 Name of tester.
 - .6 Date device tested successfully.

3.5 IDENTIFICATION OF FIRE DAMPERS AND CEILING FIRE STOPS

- .1 At all fire dampers, fire/smoke dampers, smoke control dampers and ceiling fire stops, supply and install identification tags. Tags c/w envelopes shall be of type approved by Contract Administrator.
 - .2 Envelopes shall be mechanically fastened to adjacent duct access door, or onto structure near dampers or ceiling fire stop where there is no connecting ductwork.
-

- .3 After each device has been verified as noted above, Section 15990 shall label tag with permanent ink identifying device, location (room number), inspection date, inspector's signature and TAB Agency name.

Air Handling Units

| AIR HANDLING UNIT NO. | 1 | 2 | 3 |
|--------------------------------|---------------------|---------------------|---------------------|
| SERVICE | Change Room | Gymnasium | Multi-Purpose |
| MODEL | DJ40/c/hrg | DJ100/c/hrg | DJ20/C |
| SUPPLY FAN - SIZE/TYPE | | | |
| AIRFLOW RATE (l/s) | 1543 | 2832 | 788 |
| EXTERNAL STATIC REQUIRED (Pa) | 250 | 325 | 250 |
| MOTOR (BkW/kW) | 1.5/2.23 | 4.1/5.6 | 1.1/1.5 |
| SPEED (rpm) | | | |
| PRE-FILTER SECTION | Camfil Farr 30/30 | Camfil Farr 30/30 | Camfil Farr 30/30 |
| | | | |
| FINAL FILTER SECTION | Camfil Farr Durafil | Camfil Farr Durafil | Camfil Farr Durafil |
| | | | |
| | | | |
| GLYCOL HEAT RECOVERY | | | |
| ENTERING GLYCOL TEMP. (°C) | 0.31 | .93 | N/A |
| LEAVING GLYCOL TEMP. (°C) | -1.09 | -1.13 | N/A |
| ENTERING AIR TEMP. (°C) | -40 | -40 | N/A |
| LEAVING AIR TEMP. (°C) | -10.49 | -12.24 | N/A |
| MAX. AIR PRESSURE DROP (Pa) | 91.7 | 91.7 | N/A |
| MAX. WATER PRESSURE DROP (kPa) | 50.68 | 59.09 | N/A |
| MAX. FACE VELOCITY (m/s) | 2.54 | 2.54 | N/A |
| GAS HEATING INPUT (MBH) | 400 | 900 | 100 |
| GAS HEATING OUTPUT (MBH) | 312 | 720 | 83 |
| ENTERING AIR TEMP. (°C) | -10.49 | -12.24 | 0 |
| LEAVING AIR TEMP. (°C) | 35 | 35 | 24 |
| DX TOTAL COOLING (kW) | 22.13 | 54.93 | 8.53 |
| SENSIBLE COOLING (kW) | 13.45 | 36.45 | 6.28 |
| OUTDOOR AMBIENT | | | |
| ENTERING AIR TEMP. db/wb (°C) | 30.6/23.9 | 30.6/23.9 | 26.67/19.44 |
| LEAVING AIR TEMP. db/wb (°C) | 21.1/19.6 | 19.9/17.3 | 15.63/14.36 |
| UNIT WEIGHT (lbs) | | | |
| | | | |
| | | | |
| | | | |
| | | | |
| | | | |
| | | | |

Air Handling Unit Schedule



Project: **Red River Community Centre**

File: 03-514-01

Designer: GM

Date: Mar-05

Sheet: **MS-1A**

Air Handling Units

| | | | |
|-------------------------------------|--|-------------------|--|
| AIR HANDLING UNIT NO. | | 4 | |
| SERVICE | | Kitchen | |
| MODEL | | HFC-4 | |
| SUPPLY FAN - SIZE/TYPE | | | |
| AIRFLOW RATE (l/s) | | 180 | |
| EXTERNAL STATIC REQUIRED (Pa) | | 65 | |
| MOTOR (BkW/kW) | | 0.0933 | |
| SPEED (rpm) | | 1050 | |
| | | | |
| | | | |
| | | | |
| | | | |
| PRE-FILTER SECTION | | CAMFIL FARR 30/30 | |
| | | | |
| | | | |
| GLYCOL HEAT RECOVERY | | | |
| HEATING COIL NO. & SIZE (h x l)(mm) | | N/a | |
| MEDIUM | | N/a | |
| ENTERING GLYCOL TEMP. (°C) | | N/a | |
| LEAVING GLYCOL TEMP. (°C) | | N/a | |
| ENTERING AIR TEMP. (°C) | | N/a | |
| LEAVING AIR TEMP. (°C) | | N/a | |
| MAX. AIR PRESSURE DROP (Pa) | | N/a | |
| MAX. WATER PRESSURE DROP (kPa) | | N/a | |
| MAX. FACE VELOCITY (m/s) | | N/a | |
| GAS HEATING INPUT (MBH)(kW) | | N/a | |
| GAS HEATING OUTPUT (MBH)(kW) | | N/a | |
| ENTERING AIR TEMP. (°C) | | N/a | |
| LEAVING AIR TEMP. (°C) | | N/a | |
| DX TOTAL COOLING (TONS)(kW) | | 3.25 | |
| SENSIBLE COOLING (TONS)(kW) | | 2.44 | |
| OUTDOOR AMBIENT | | | |
| ENTERING AIR TEMP. db/wb (°C) | | 26.67/19.44 | |
| LEAVING AIR TEMP. db/wb (°C) | | 15.63/14.36 | |
| UNIT WEIGHT (lbs) | | | |
| UNIT ACCESSORIES | | | |

Air Handling Unit Schedule



Project: **Red River Community Centre**

File: 03-514-01

Designer: GM

Date: Mar-05

Sheet: **MS-1B**

Fan Schedule

| FAN NO. | SERVICE | FAN TYPE | LOCATION | FAN MODEL | CAP. (cfm) (l/s) | E.S.P. (in. W.G.) (Pa) | SPD. (rpm) | OUT. VEL. (fpm) (m/s) | BRK. (HP) (BkW) | MTR. (HP) (kW) | REMARKS |
|---------|--------------------|------------|-------------------|---------------|---------------------|---------------------------|------------|--------------------------|--------------------|-------------------|--------------------------|
| EF-1 | GYM RETURN | GREEN-HECK | MECH MEZZ | BDF-180 | 6000 2832 | 1.00 250 | 647 | 0.00 | 2.25 1.68 | 3.00 2.24 | INTERLOCK WITH AHU-2 |
| EF-2 | RANGE HOOD | NUTONE | KITCHEN | TN8330WW | 250 118 | 0 | | 0.00 | 0.00 | 0.00 | FRAC DUCTED |
| EF-3 | CHANGE ROOM VENT | GREEN-HECK | JANITOR | BDF-120 | 3270 1543 | 0.75 188 | 776 | 0.00 | 0.74 0.55 | 1.00 0.75 | INTERLOCK WITH AHU-1 |
| F-1 | DESTRAT | BANVIL | TOWER | 136F-7 36" | 9000 | | | | | | SPEED SWITCH |
| EF-4 | Zamboni Rm Exhaust | Greenheck | Roof Above Rm 126 | GB-081 | 300 142 | 0.25 60 | 900 | 312 | 0.03 | 0.17 | Gas Detection Controlled |
| | | | | | | | | | | | |
| | | | | | | | | | | | |
| | | | | | | | | | | | |
| | | | | | | | | | | | |
| | | | | | | | | | | | |
| | | | | | | | | | | | |
| | | | | | | | | | | | |
| | | | | | | | | | | | |
| | | | | | | | | | | | |
| | | | | | | | | | | | |
| | | | | | | | | | | | |
| | | | | | | | | | | | |
| | | | | | | | | | | | |
| | | | | | | | | | | | |
| | | | | | | | | | | | |
| | | | | | | | | | | | |
| | | | | | | | | | | | |

Fan Schedule



Project: **Red River Community Centre**

File: 04-514-01

Designer: gm

Date: Mar-05

Sheet: **MS-2**

Glycol Heat Recovery

| SYSTEM NAME | COIL NO. EXH. SIDE | COIL NO. SUPP. SIDE | ENTER. AIR | | FLOW THRU COIL (l/s) | MAX WTR. DROP (kPa) | OPER. TIME | | SYSTEM HEAT TRANSFER (kW/HEATING SEASON) | REMARKS |
|-------------------------|--------------------|---------------------|------------|--------|----------------------|---------------------|------------|---------|--|---------------------|
| | | | TEMP. (°C) | % R.H. | | | hrs/day | day/wk. | | |
| AHU-1 | HRC 3 | HRC 4 | -40 | 80 | 4.54 | 26 E 51 S | 24 | 7 | 23.34 | 1543 l/s Airflow |
| AHU-2 | HRC 1 | HRC 2 | -40 | 80 | 7.07 | 34 E 60 S | 24 | 7 | 52.7 | 2831 l/s Airflow |
| | | | | | | | | | | |
| | | | | | | | | | | |
| | | | | | | | | | | |
| | | | | | | | | | | |
| | | | | | | | | | | |
| | | | | | | | | | | |
| | | | | | | | | | | |
| | | | | | | | | | | |
| | | | | | | | | | | |
| | | | | | | | | | | |
| | | | | | | | | | | |
| | | | | | | | | | | |
| | | | | | | | | | | |
| | | | | | | | | | | |
| | | | | | | | | | | |
| | | | | | | | | | | |
| | | | | | | | | | | |
| | | | | | | | | | | |
| | | | | | | | | | | |
| | | | | | | | | | | |
| | | | | | | | | | | |
| | | | | | | | | | | |
| Based on Engineered Air | | | | | | | | | | |

| | | | | | | | | | | |
|---|--|--|--|--|--|--------------------|--|--|--|--|
|  | Glycol Heat Recovery Schedule | | | | | | | | | |
| | Project: Red River Community Centre | | | | | | | | | |
| | File: 03-514-01 | | | | | Designer: GM | | | | |
| | Date: Mar-05 | | | | | Sheet: MS-4 | | | | |

Pump Schedule

| NO. | SERVICE | LOCATION | MODEL / SIZE | CAP. (gpm) (l/s) | HEAD (ft) (m) | MTR. (HP) (kW) | SPD. (rpm) | REMARKS |
|------------|---------------------------|-----------------|---------------------|---------------------------------|------------------------------|-------------------------------|-----------------------|-----------------------------|
| P-3 | Glycol Heat Recovery Loop | East Mech Rm | 60 2 x 7 | 112 7.06 | 42 12.80 | 3 2.24 | 1800 | Gym Recovery System |
| P-4 | Glycol Fill Tank | East Mech Rm | Axiom MF 200 | 0.7 0.04 | 0 0.00 | 0.07 0.05 | | |
| P-5 | Glycol Fill Tank | West Mech Rm | Axiom MF 200 | 0.7 0.04 | 0 0.00 | 0.07 0.05 | | |
| P-6 | Glycol Heat Recovery Loop | West Mech Rm | 60 2 x 6-1/4 | 72 4.54 | 34 10.37 | 1.5 1.12 | 1800 | Change Room Recovery System |
| | | | | | | | | |
| | | | | | | | | |
| | | | | | | | | |
| | | | | | | | | |
| | | | | | | | | |
| | | | | | | | | |
| | | | | | | | | |
| | | | | | | | | |
| | | | | | | | | |
| | | | | | | | | |
| | | | | | | | | |
| | | | | | | | | |
| | | | | | | | | |
| | | | | | | | | |
| | | | | | | | | |
| | | | | | | | | |
| | | | | | | | | |

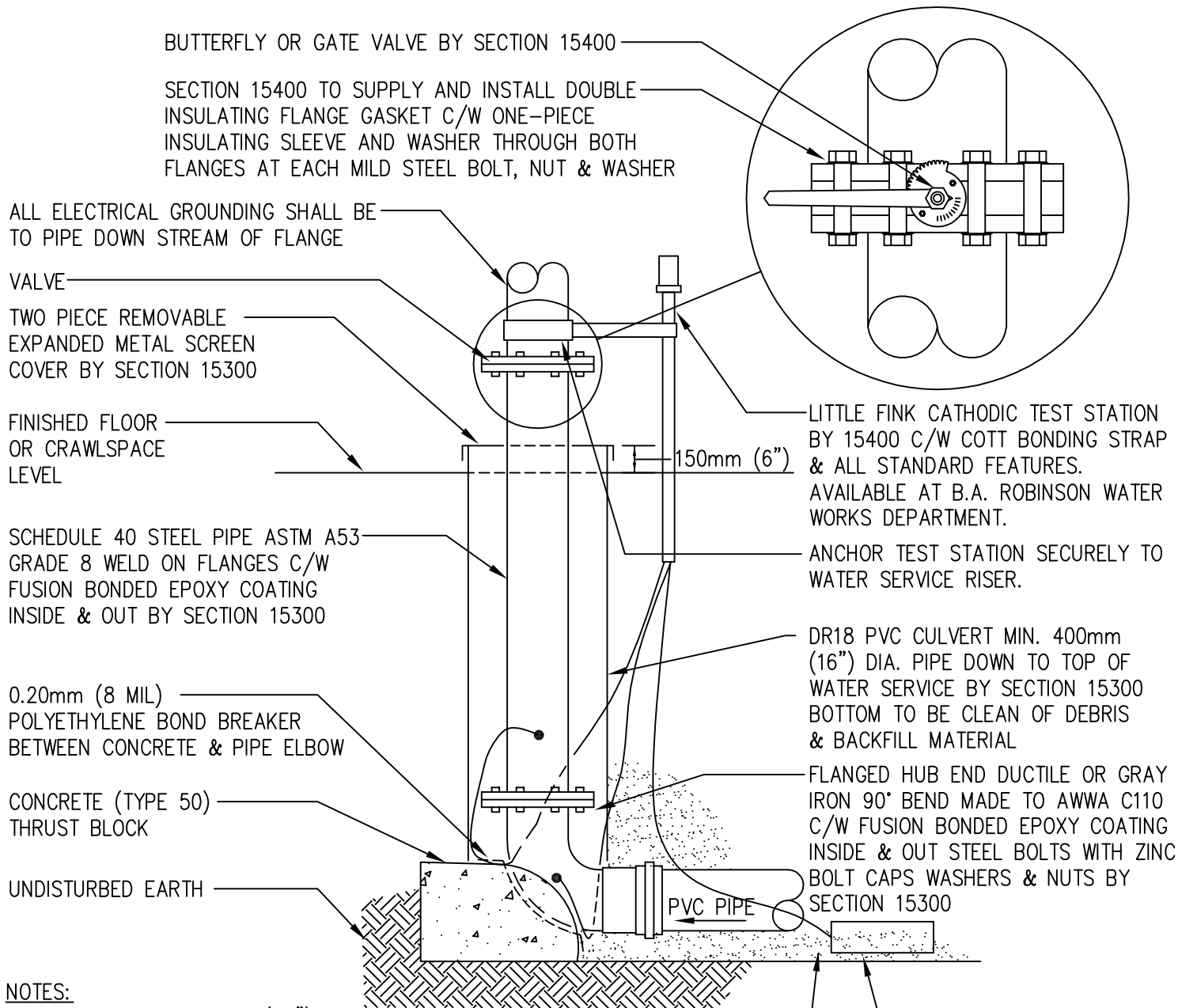

NOTES:

- INSTALL ANODE MIN 1M (36") FROM BEND, AND AT SAME ELEVATION.
- CADWELD LEAD WIRE TO PIPE AND SEAL WITH HANDY CAP ELECTRICAL RESISTANT INSULATION KIT
- WRAP LEAD WIRES ONCE AROUND PIPING TO REDUCE STRESS ON WELDED CONNECTION DURING BACKFILL.
- 2.3KG (5LB) ANODE IS SIZED FOR 150mm (6") AND 200mm (8") DIAMETER PIPE SIZE, WITH SUPERIOR CORROSION PROTECTION COATING, AND 2.44M (8') OF RISER PIPE EXPOSED TO SOIL.

DETAIL OF WATER SERVICE ENTRY

N.T.S

SMS ENGINEERING

SMS Engineering Ltd. Consulting Engineers
 770 Bradford Street Winnipeg MB Canada R3H 0N3
 Telephone 204.775.0291 Fax 204.772.2153
 sms@smseng.com

SPECIFICATION DETAIL

STEEL RISER C/W FLANGE AND HUB PVC ELBOW

| | | |
|-----------------------|--------------------|----------------------|
| Drawn By SMS | Approved By IDK | Reference 3050 |
| File No. 03-514-01 | Date 2004/12/21 | Detail Sheet MD-1 |

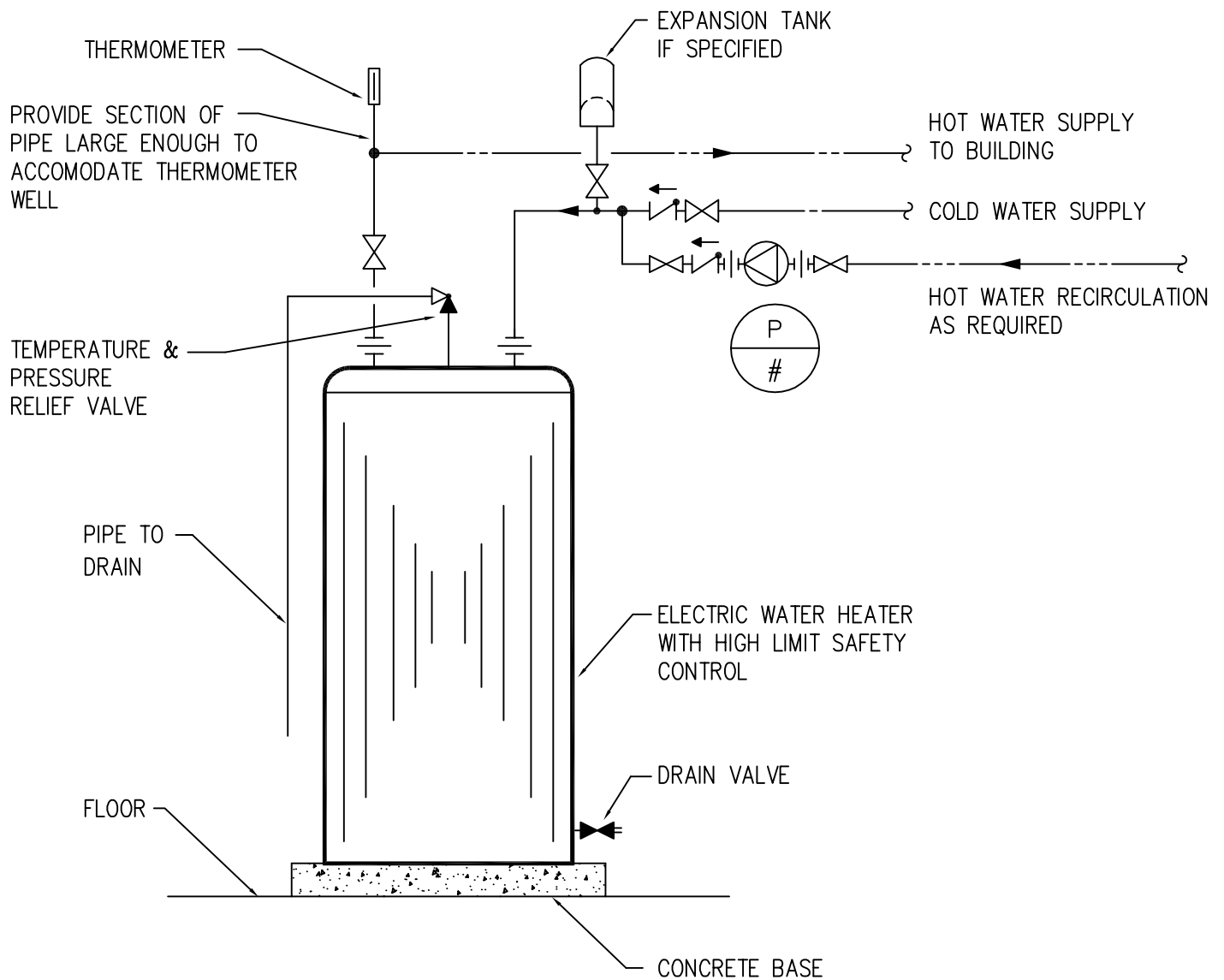

DETAIL OF HOT WATER TANK—ELECTRIC
NTS

SMS ENGINEERING

SMS Engineering Ltd. Consulting Engineers
770 Bradford Street Winnipeg MB Canada R3H 0N3
Telephone 204.775.0291 Fax 204.772.2153
sms@smseng.com

**SPECIFICATION
DETAIL**

**DOMESTIC WATER HEATER
'ELECTRIC TYPE'**

| | | |
|-----------------------|--------------------|----------------------|
| Drawn By SMS | Approved By SMS | Reference 4001 |
| File No. 03-514-01 | Date 2004/12/21 | Detail Sheet MD-2 |

LUBRICATED FULL WIDTH HINGE.

1" PIPE SLEEVE FOR FLOAT CONTROL CABLE GUIDE

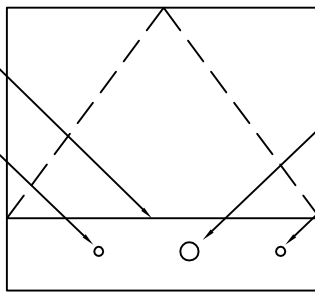

2" PIPE SLEEVE FOR DISCHARGE PIPING.

1" PIPE SLEEVE(S) FOR ELECTRICAL AS REQUIRED.

PLAN OF COVER
N.T.S.

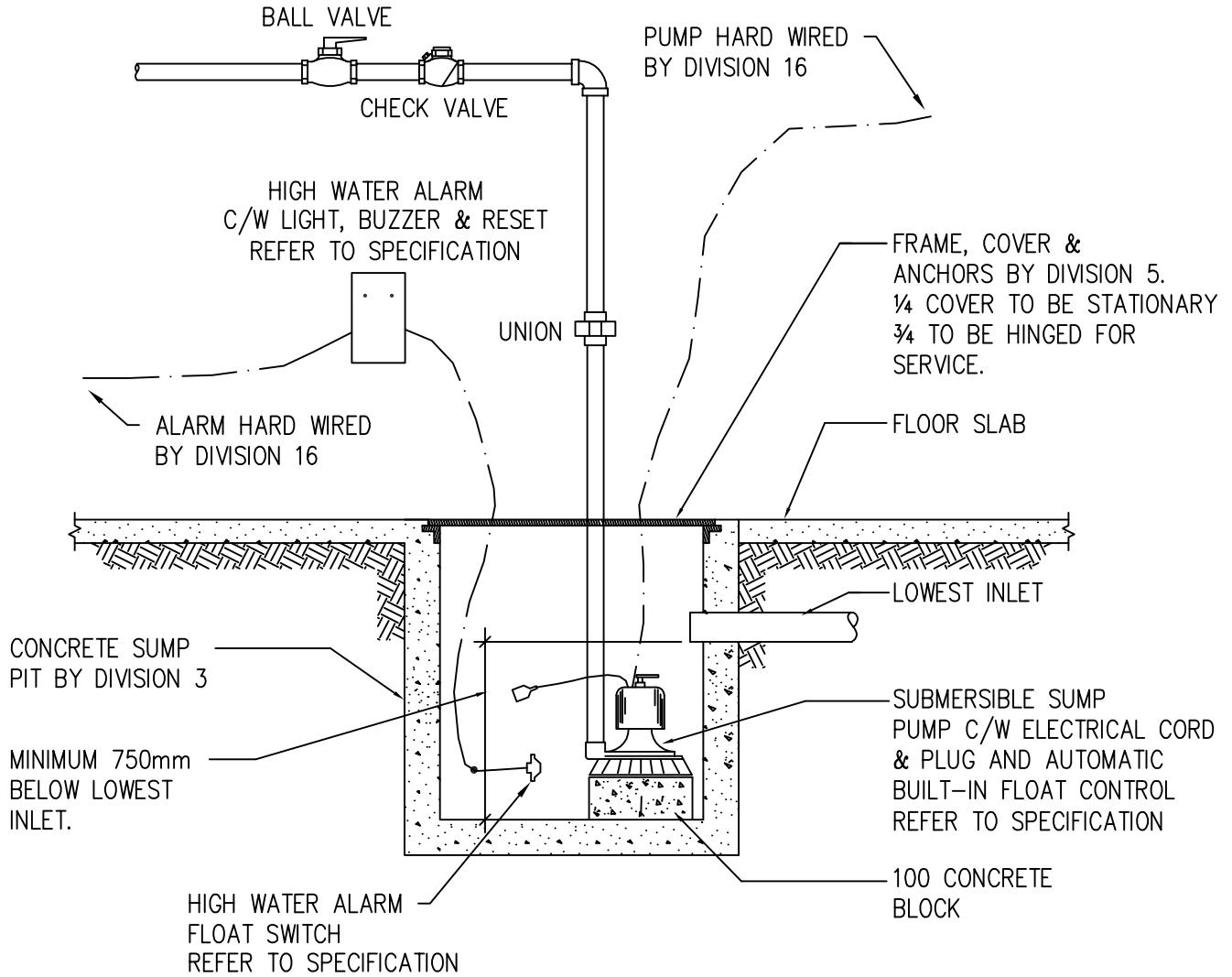

DETAIL OF SUBMERSIBLE SUMP PUMP
N.T.S.

SMS ENGINEERING

SMS Engineering Ltd. Consulting Engineers
770 Bradford Street Winnipeg MB Canada R3H 0N3
Telephone 204.775.0291 Fax 204.772.2153
sms@smseng.mb.ca

**SPECIFICATION
DETAIL**

**SUBMERSIBLE SUMP PUMP DETAIL
FOR FINISHED FLOOR**

| | | |
|-----------------------|--------------------|----------------------|
| Drawn By SMS | Approved By JTW | Reference 4073 |
| File No. 03-514-01 | Date 2004/12/21 | Detail Sheet MD-3 |

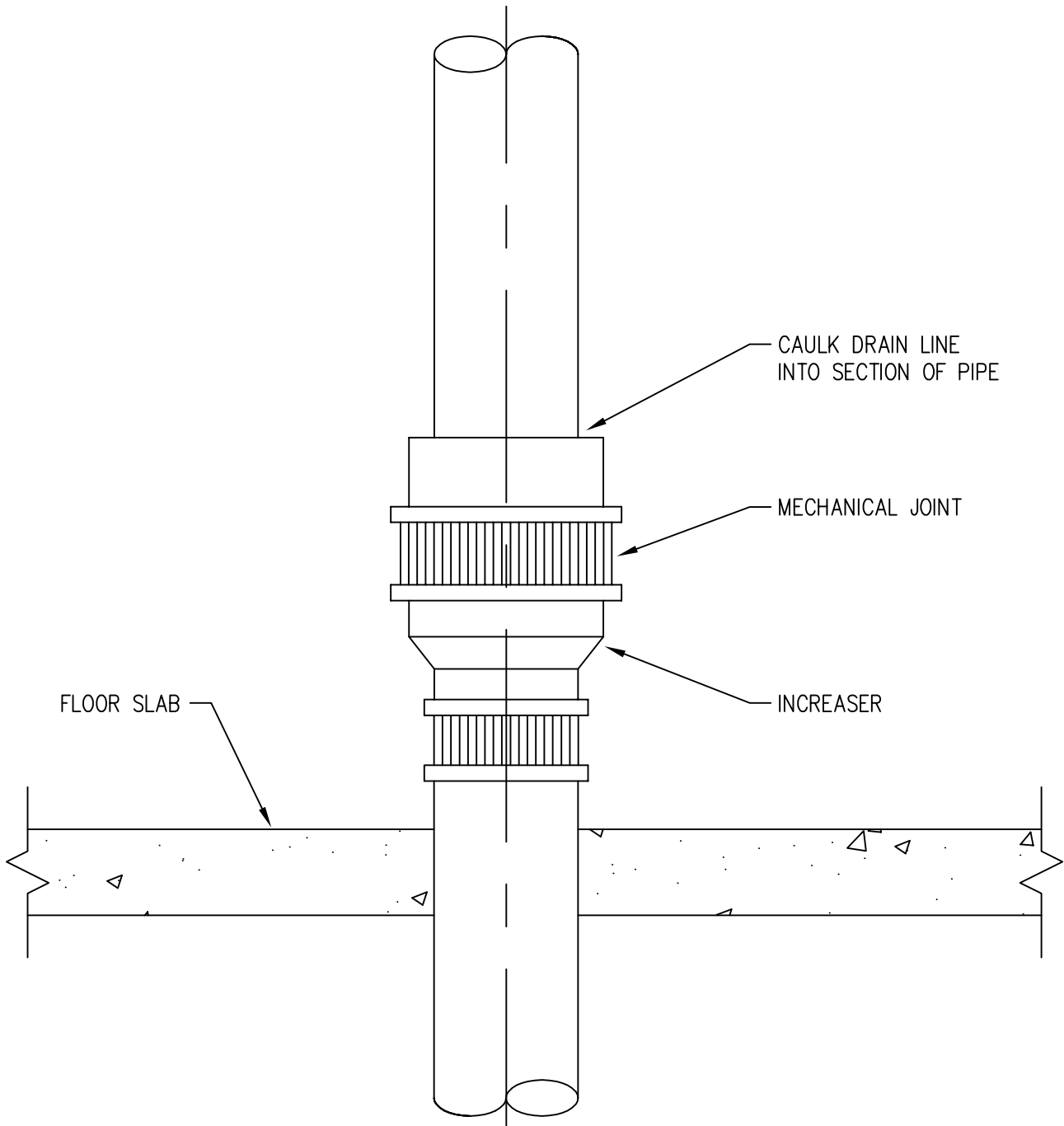

SISSON JOINT DETAIL

N.T.S.

SMS ENGINEERING

SMS Engineering Ltd. Consulting Engineers
 770 Bradford Street Winnipeg MB Canada R3H 0N3
 Telephone 204.775.0291 Fax 204.772.2153
 sms@smseng.com

**SPECIFICATION
 DETAIL**

SISSON JOINT DETAIL

| | | |
|-----------------------|--------------------|----------------------|
| Drawn By SMS | Approved By SMS | Reference 4154 |
| File No. 03-514-01 | Date 2004/12/21 | Detail Sheet MD-4 |

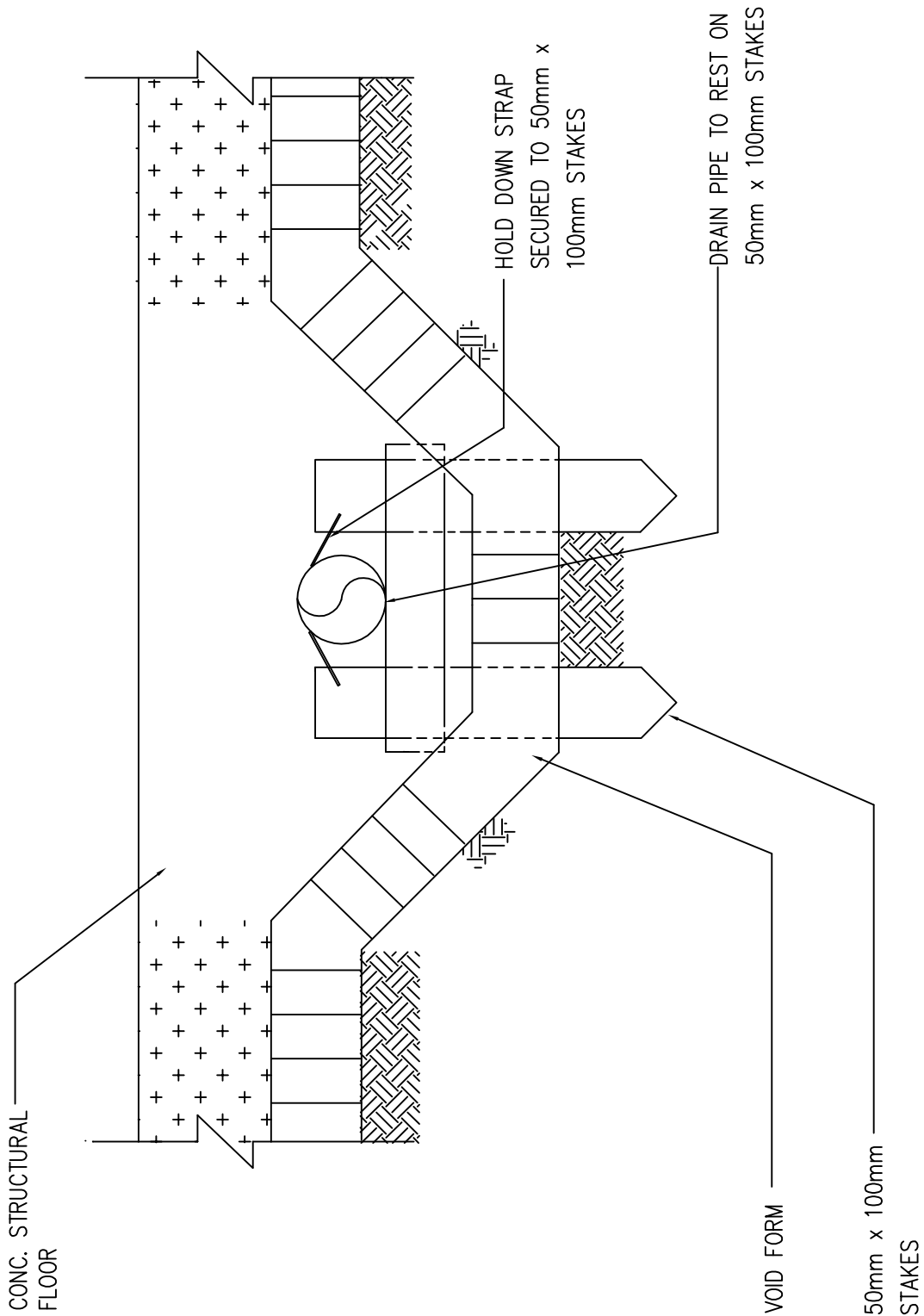

DETAIL OF PIPE SUPPORT FOR CONCRETE ENCASED DRAINS

N.T.S

SMS ENGINEERING

SMS Engineering Ltd. Consulting Engineers
 770 Bradford Street Winnipeg MB Canada R3H 0N3
 Telephone 204.775.0291 Fax 204.772.2153
 sms@smseng.com

SPECIFICATION DETAIL

PIPE SUPPORT FOR CONCRETE STRUCTURAL SLAB

| | | |
|-----------------------|--------------------|----------------------|
| Drawn By SMS | Approved By SMS | Reference 4300 |
| File No. 03-514-01 | Date 2004/12/21 | Detail Sheet MD-6 |

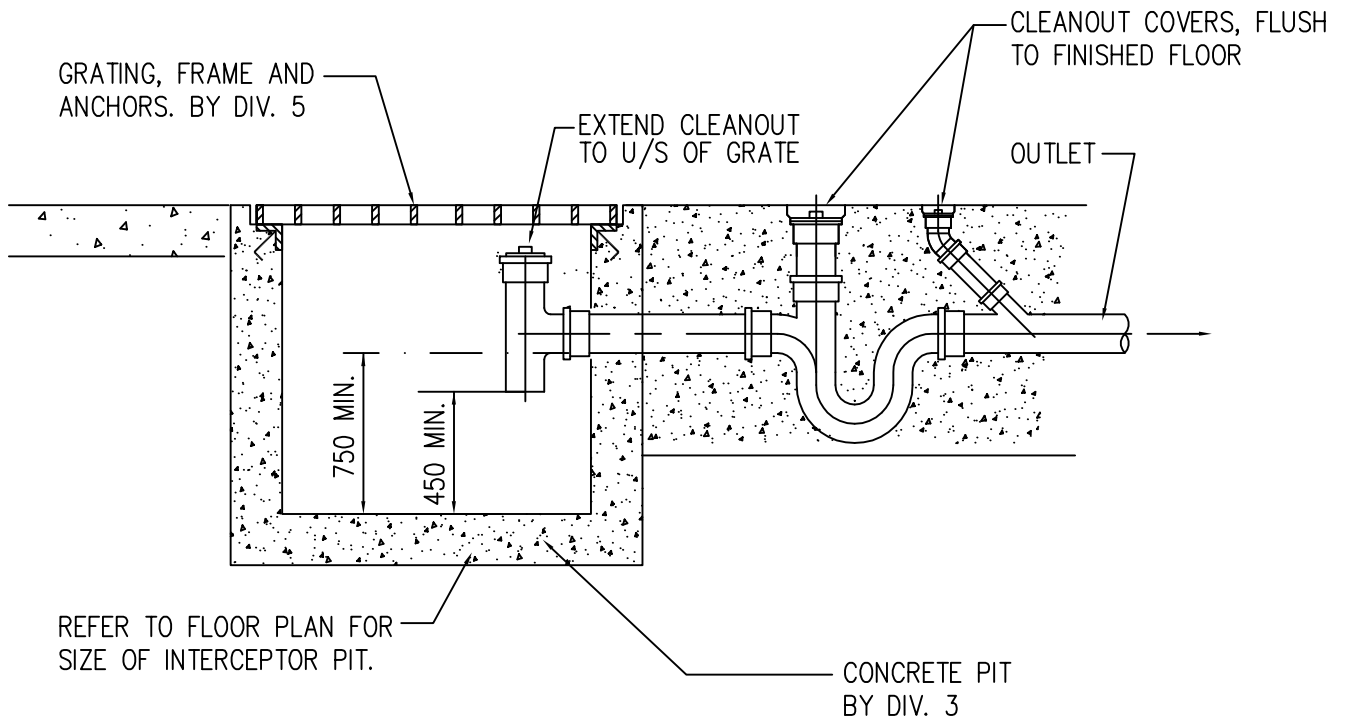

DETAIL OF GRIT INTERCEPTOR PIT
 N.T.S.

SMS ENGINEERING

SMS Engineering Ltd. Consulting Engineers
 770 Bradford Street Winnipeg MB Canada R3H 0N3
 Telephone 204.775.0291 Fax 204.772.2153
 sms@smseng.com

**SPECIFICATION
 DETAIL**

**GRIT INTERCEPTOR PIT DETAIL
 STRUCTURAL SLAB**

| | | |
|-----------------------|--------------------|----------------------|
| Drawn By SMS | Approved By SMS | Reference 4140 |
| File No. 03-514-01 | Date 05-03-23 | Detail Sheet MD-7 |

1.1 RELATED WORK

.1 Bidding & Contract Requirements Division 0

.2 General Requirements

.3 All Electrical Drawings

1.2 QUALITY ASSURANCE

.1 Do complete installations in accordance with CSA C22.1-2002.

.2 While not identified and specified by number in this Division, comply with CSA Electrical Bulletins in force at time of tender submission. Comply with the requirements of all Provincial and local laws, rules, ordinances and codes.

.3 Electrical installation shall be in accordance with the current edition of the Canadian Electrical Code, Provincial and other codes, rules and regulations. Supply material and labour required to meet the requirements of these codes, rules and regulations even though the Work is not shown on the drawings or mentioned in the specifications. Where the electrical installation calls for better quality materials or construction than the minimum requirements of these codes, rules and regulations, the electrical installation shall be as shown on the drawings and as specified.

.4 Electrical installation shall be in accordance with the requirements of the electrical supply authority and local inspection authority.

1.3 PERMITS, FEES

.1 Submit to Electrical Inspection Department and Supply Authority necessary number of drawings and specifications for examination and approval prior to commencement of the Work.

.2 Obtain all necessary permits and pay all fees as required for the electrical installation.

1.4 MATERIALS AND EQUIPMENT

.1 Provide labour, materials, transportation, equipment and facilities, etc., required for the complete electrical installation as indicated or implied on the drawings and specifications.

.2 Electrical equipment shall be new and of type and quality specified.

.3 Equipment and material shall be CSA certified, and manufactured to standards described. Where there is no alternative to supplying equipment which is not CSA certified, obtain special approval from the appropriate Inspection Departments.

1.5 SUBMITTALS

.1 Submit shop drawings and product data for review by the Contract Administrator. All drawings shall be in English and Imperial dimensions or in metric where indicated. Manufacture of equipment shall not commence until shop drawings have been reviewed.

- .2 Indicate details of construction, dimensions, capacities, weights and electrical performance characteristics of equipment or material. Where applicable, include wiring, single line and schematic diagrams.
- .3 Submit shop drawings of service entrance equipment to utilities.
- .4 Material submitted for Contract Administrator's review shall bear Contractor's, and where applicable, Utility reviewed stamp.

1.6 OPERATIONS AND MAINTENANCE DATA

- .1 Provide operation and maintenance data for incorporation into Maintenance Manuals, including names and addresses of local suppliers for items included in Maintenance Manuals.
- .2 Include details of design elements, construction features, component function and maintenance requirements, to permit effective start-up, operation, maintenance, repair, modification, extension and expansion of any portion or feature of installation.
- .3 Include technical data, product data, supplemented by bulletins, component illustrations, exploded views, technical descriptions of items, and parts lists. Advertising or sales literature not acceptable.
- .4 Include wiring and schematic diagrams and performance curves.
- .5 Submit 4 copies of Maintenance Manuals to the Contract Administrator for review. Manuals that are incomplete shall be returned to the Contractor for completion. Completed manuals shall be submitted, to the satisfaction of the Contract Administrator, before substantial completion may be considered.

1.7 VOLTAGE RATINGS

- .1 Operating voltages: to CAN3-C235-83.
- .2 Motors, electrical heating, control and distribution devices and equipment to operate satisfactorily at 60 Hz within normal operating limits established by above standard. Equipment shall operate in extreme operating conditions established in above standard without damage to equipment.

1.8 INSPECTION

- .1 Furnish a Certificate of Acceptance from the Inspection Authorities on completion of the Work. Copies of certificate shall be included in Maintenance Manuals. Certificate shall be submitted before final payment may be considered to be due.
- .2 During the course of the project construction, the Contract Administrator will carry out periodic site reviews and prepare a deficiency list for remedial action by the Contractor. The Contractor shall respond in writing to the Contract Administrator, stating corrective action and completion date for each item listed as deficient.

1.9 CARE, OPERATION AND START-UP

- .1 Instruct the City's operating personnel in the operation, care and maintenance of equipment. Arrangement of such instructional sessions shall be done at a time convenient to the City, and ensure that operating personnel are conversant with all aspects of its care and operation.
- .2 Arrange and pay for services of Manufacturer's factory service engineer to supervise start-up of installation, check, adjust, balance and calibrate components.

1.10 FINISHES

- .1 Finish outdoor electrical equipment such as parking lot panels, to match light standards.
- .2 Paint indoor switchgear and distribution enclosures light grey to EEMAC-2Y-1. Outdoor electrical equipment enclosures shall be painted "equipment green" to EEMAC 2Y-1.
- .3 Clean and touch up surfaces of shop-painted equipment, scratched or marred during shipment or installation, to match original paint.
- .4 Clean, prime and paint exposed hangers, racks, fastenings to prevent rusting.

1.11 EQUIPMENT IDENTIFICATION

- .1 Identify electrical equipment with lamacoid nameplates.
- .2 Provide lamacoid nameplates, 1/8" (3mm) thick plastic engraving sheet, black or red face, white core, mechanically attached (screwed or riveted) unless specified otherwise. Sizes as follows:

| | | | | | |
|--------|---------------|--------------|---------|-------|---------------------|
| Size 0 | 3/8" x 1-1/2" | (10 x 38mm) | 1 line | 1/8" | (3mm) high letters |
| Size 1 | 3/8" x 4" | (10 x 100mm) | 1 line | 1/8" | (3mm) high letters |
| Size 2 | 1/2" x 3" | (13 x 75mm) | 1 line | 3/16" | (5mm) high letters |
| Size 3 | 1/2" x 3" | (13 x 75mm) | 2 lines | 1/8" | (3mm) high letters |
| Size 4 | 3/4" x 3" | (19 x 75mm) | 1 line | 3/8" | (10mm) high letters |
| Size 5 | 3/4" x 4" | (19 x 100mm) | 2 lines | 3/16" | (5mm) high letters |
| Size 6 | 1" x 4" | (25 x 100mm) | 1 line | 1/2" | (13mm) high letters |
| Size 7 | 1" x 4" | (25 x 100mm) | 2 lines | 1/4" | (6mm) high letters |
- .3 Wording on nameplates shall be approved prior to manufacture. Submit schedule of nameplates and wording.
- .4 Allow for average of twenty-five (25) letters per nameplate.
- .5 Identification shall be English.
- .6 Nameplates for terminal cabinets and junction boxes shall indicate system and/or voltage characteristics.
- .7 Use black nameplates with white lettering for normal power and communications equipment. Use red nameplates with white lettering for emergency power and fire alarm equipment.

1.12 PROJECT RECORD DOCUMENTS

- .1 Project record documents shall be transferred to electronic disc Autocadd file and labelled "Record Drawings". The Contractor shall be responsible for the production of electrical as-constructed drawings which shall provide a complete and accurate record of the actual electrical installation. The Contractor shall affix his company name and the words "Record Drawings" on the drawings, and sign and date them. Submit disc and hard copy for final review and submission to the City upon completion. Record documents that are incomplete shall be returned to the Contractor for remedial measures.

1.13 LABELS AND WARNING SIGNS

- .1 Manufacturer's nameplates and CSA labels shall be visible and legible after equipment is installed.
- .2 Provide warning signs on equipment, as required, to meet the requirements of the Inspection Authorities, including indication of multiple power sources.

1.14 EQUIPMENT MATERIALS AND EQUIPMENT

- .1 Bidders shall submit a tender based on the specified materials and equipment only.
- .2 Bidders may submit a tender based on equivalent materials and equipment only if such items have been approved as equals by the Contract Administrator.
- .3 Bidders may submit, with their tender, an alternate price based on alternate materials and equipment only if such items have been approved as alternates by the Contract Administrator.
- .4 Submissions for equals or alternates shall be received by the Contract Administrator five (5) working days prior to tender closing. Submissions shall include sufficient Manufacturer's data to clearly show equivalency, as well as an itemized list of equal or alternate items, the items for which they were submitted and a space for the Contract Administrator to indicate 'approved equal', 'approved alternate', or 'not approved'. Submittal list will be returned by facsimile machine, where a number is shown, or may be picked up at the Contract Administrator's Office.

1.15 LOCATION OF OUTLETS

- .1 Locate outlets as indicated.
- .2 Do not install outlets back-to-back in wall; allow minimum 16" (400mm) horizontal clearance between boxes.
- .3 Drawings are schematic only and do not indicate all architectural or structural elements.
- .4 Change location of outlets at no extra cost or credit, providing distance does not exceed 10'-0" (3m) and information is provided before installation.
- .5 Locate light switches on latch side of doors.
- .6 Vertically align outlets of different systems when shown in close proximity to each other and occurring at different mounting heights.

- .7 Coordinate mounting heights and location of all equipment with Architectural, Mechanical and Structural Drawings prior to installation of rough-in boxes.

1.16 MOUNTING

- .1 Mounting height of equipment is from finished floor to centreline of equipment unless specified or indicate otherwise.
- .2 If mounting height of equipment is not indicated, verify with Contract Administrator before proceeding with installation.
- .3 Install electrical equipment at the following heights unless indicated or directed otherwise (to middle of outlet).
 - .1 Outlets above counters: 6" (150mm); splashbacks: 4" (100mm).
 - .2 General receptacles, telephone and television outlets: 16" (400mm).
 - .3 Receptacles in mechanical areas: 40" (1m).
 - .4 Switches, dimmers, push buttons: 48" (1.2m).
 - .5 Fire alarm pullstations, thermostats: 46" (1.2m).
 - .6 End of line resistors: 64" (1.6m).
 - .7 Fire alarm bells, horns, speakers: 88" (2.2m).
 - .8 Panelboards, annunciators, etc.: 78" (2.0m) to top.
 - .9 Clock outlets: 84" (2.15m).
 - .10 Handicap suite switches, dimmers, pushbuttons: 40" (1.2m).
 - .11 Handicap suite receptacles, television, telephone: 24" (600m).
 - .12 Handicap suite thermostats: 48" (1.2m).
 - .13 As per Architectural elevations.
 - .14 Heights as above or at bottom of nearest block or brick course.
 - .15 Occupancy sensor as per Manufacturer's instruction.

1.17 PROTECTION

- .1 Protect exposed live equipment during construction for personnel safety.
- .2 Shield and mark live parts "LIVE () VOLTS", with appropriate voltage in English.
- .3 Arrange for installation of temporary doors for rooms containing electrical distribution equipment. Keep these doors locked except when under direct supervision.

1.18 LOAD BALANCE

- .1 Measure phase current to panelboards with normal loads operating at time of measurement. Adjust branch circuit connections as required to obtain best balance of current between phases, record changes and add to record drawings.

1.19 CONDUIT SLEEVES AND HOLES

- .1 Install conduit, and sleeves, prior to pouring of concrete. Sleeves through concrete shall be sized for free passage of conduit.
- .2 Holes through exterior walls and roof shall be flashed and made weatherproof.
- .3 Make necessary arrangements for cutting of chases, drilling of holes and other structural Work required to install electrical conduits, cables, pullboxes and outlet boxes.
- .4 Install cables, conduits, and fittings to be embedded or plastered over, neatly and close to building structure so furring can be kept to minimum.

1.20 FIREPROOFING

- .1 Where cables or conduits pass through floors, block or concrete walls and fire rated walls, seal openings with fire-stopping material with intumescent properties.
- .2 Fire proofing of electrical cables, conduits, trays, etc., passing through fire barriers shall conform to local codes and inspection authorities.
- .3 Fire stop materials shall be asbestos free and have been tested in accordance with ASTM E-84, E-136 and E-814 and UC-1479.
- .4 Approved Manufacturer:
 - .1 Nelson Firestop Products
 - .2 Spec Seal

1.21 INSULATION RESISTANCE TESTING

- .1 Megger circuits, feeders and equipment up to 350V with a 500V instrument.
- .2 Megger 350-600V circuits, feeders and equipment with a 1000V instrument.
- .3 Check resistance to ground before energizing.

1.22 CLEANING

- .1 Do final cleaning in accordance with Section 01710.
- .2 At time of final cleaning, clean lighting reflectors, lenses, and other lighting surfaces that have been exposed to construction dust and dirt.

1.23 DELIVERY STORAGE AND HANDLING

- .1 Deliver all materials to site in an orderly fashion.
- .2 Store all materials in a clean and dry place, secure from vandalism or theft. All materials shall be left in shipping containers until required for use.
- .3 Provide additional protection such as tarps, padding, wood skids, etc., where such is required to ensure protection of equipment.

1.24 COORDINATION WITH OTHER TRADES

- .1 Refer to Mechanical, Structural, Architectural and Interior Design drawings and specifications for additional electrical Work in connection with other Divisions. Where such Work is included in other sections of the specifications, provide equipment, conduit, wiring, etc. (in accordance with the Manufacturer's approved shop drawings), as required, for operation of the specified equipment.
- .2 Coordinate electrical Work with Work of other trades to avoid conflicts with pipes, air ducts or other equipment. Provide additional supports, wiring, etc. to relocate electrical equipment, as required, where structural members, air ducts, piping or other equipment interferes with the electrical installation.

1.25 EXAMINATION OF SITE AND CONSTRUCTION DOCUMENTS

- .1 Prior to submitting a bid, examine the site and local conditions which will affect the Work. Refer to the Architectural, Mechanical and Structural drawings, schedules and specifications for construction details to be certain that the electrical Work can be satisfactorily carried out as specified. Claims for extra payments, resulting from conditions which could reasonably be foreseen during an examination of the documents and/or site, will not be recognized.
- .2 Ensure that all equipment designated as "Existing to Remain" or "Existing to be Relocated" is suitable for its intended re-use, including panelboards and circuits. Report any discrepancies to the Contract Administrator BEFORE close of bid opportunity.
- .3 Refer to Supplemental Conditions for instructions regarding any pre-arranged site visit during the bidding period.

1.26 CUTTING AND PATCHING

- .1 Pay the costs of all cutting and patching required for the installation of electrical Work. Payment for cutting and patching shall be made through the Contractor.
- .2 Obtain the approval of the Contract Administrator before arranging for any cutting. Patching shall restore the affected area to the original condition; materials and methods used for patching shall be in accordance with the requirements of the corresponding Divisions of the specification.

1.27 WORKMANSHIP

- .1 Install equipment, conduit and cables in a workmanlike manner to present a neat appearance to the satisfaction of the Contract Administrator. Install conduit and cable

runs parallel and perpendicular to building lines in chases, behind furring or above ceilings, where such concealment is possible. In areas where systems shall be exposed, install neatly and group in a tidy appearance.

- .2 Install equipment and apparatus requiring maintenance, adjustment or eventual replacement, with adequate clearances and accessibility for same.
- .3 Replace Work unsatisfactory to the Contract Administrator without extra cost.

1.28 ACCESS DOORS

- .1 Access doors shall be a minimum #12 gauge prime coat painted bonderized steel. Each shall be complete with a heavy flush frame and anchor, concealed hinges, positive locking screwdriver lock, and mounting and finishing provisions to suit the finish material for which they are supplied. Access doors in fire rated ceilings, walls, partitions, structures, etc. shall be U.L.C. listed and labelled and of a rating to maintain the fire separation integrity.
- .2 Before commencing installation of electrical Work submit, to the Contract Administrator for approval, a list of required access doors showing the exact sizes and locations of such access doors. Locate access doors in walls and partitions to the Contract Administrator's approval, and arrange electrical Work to suit. Access doors shall be, wherever possible, of a standard size for all applications. Confirm exact dimensions with the Contract Administrator, prior to ordering.
- .3 Access doors shall be installed by the Division responsible for the particular type of construction in which access doors are required. Supply the access doors to the Division installing same at the proper time to avoid construction delays.

1.29 SPARE PARTS

- .1 Assemble spare parts as specified:
- .2 Include the following:
 - .1 Part number
 - .2 Identification of equipment or system for which parts are applicable
 - .3 Installation instructions as applicable
- .3 Provide a written list complete with City's signature assuring that spare parts have been received by the City.
- .4 Substantial Performance

The Contract Administrator shall make a Representative available for one substantial performance inspection within one week of receipt of the following:

- .1 Verification Certificate and complete report for fire alarm and life safety system by the fire alarm manufacturer indicating that the system is complete, tested and in conformance with the specification and local jurisdiction requirements. Refer to Fire Alarm System Section.

- .2 A letter from the Contractor stating that the fire alarm system, exit and emergency lighting is complete, tested and fully operational as per the plans and specifications, including all formal changes to the Contract. The letter shall further state that all deficiencies cited by the Contract Administrator or local Electrical or Building Inspector have been completed and accepted.
- .3 A letter from each system supplier indicating that the following systems are complete and tested as per the specifications and ready for operation:
 - .1 Intercom system
 - .2 Local area network (LAN)
 - .3 Security system
 - .4 Voice/Data Communication
 - .5 Telephone system
- .4 Completed and approved Maintenance Manuals as per Item 16050.1.6.
- .5 Completed and approved Record Drawings as per Item 16050.1.12.
- .5 Before or during the substantial performance inspection, the Contractor shall prove the proper performance of all fire alarm, nurse call, emergency call, and life safety systems and all other systems, in the presence of and to the satisfaction of the Contract Administrator, local inspection authorities and the City (or representative).

END OF SECTION

- 1.1 RELATED WORK
 - .1 Basic Electrical Materials and Methods Section 16050
 - .2 Fastenings and Supports Section 16126
- 1.2 LOCATION OF CONDUIT
 - .1 Drawings do not show all conduits. Those shown are diagrammatic form only.
 - .2 Contractor shall produce layout sketches of conduit runs through mechanical and electrical service areas in order to pre-avoid any conflict with other construction elements and to determine the most efficient route to run conduits.
- 1.3 CONDUITS
 - .1 Rigid galvanized steel threaded conduit.
 - .2 Electrical metallic tubing (EMT), with couplings.
 - .3 Water-tight flexible conduits with couplings.
 - .4 Rigid PVC conduits.
- 1.4 CONDUIT FASTENINGS
 - .1 One hole steel straps to secure surface conduits 1-1/4" (35mm) and smaller. Two hole steel straps for conduits larger than 1-1/4" (35mm).
 - .2 Beam clamps to secure conduits to exposed steel Work.
 - .3 U-channel type supports as specified for two or more conduits at 60" (1.52m) intervals (surface-mounted or suspended).
 - .4 3/8" (10mm) diameter threaded rods to support suspended channels. One rod shall be non-ferrous.
- 1.5 CONDUIT FITTINGS
 - .1 Fittings manufactured for use with conduit specified. Provide manufactured elbows where 90° bends are required for 2-1/2" (63mm) and larger conduits.
 - .2 Die cast set screw connectors and couplings. Insulated throat liners on connectors.
 - .3 Raintight connector fittings complete with O-rings, for use on weatherproof or sprinklerproof enclosures. Raintight couplings shall be used for surface conduit installations exposed to moisture or sprinkler heads. Raintight connectors shall be used for all top entries to panels, contactors and motor control centres.
- 1.6 EXPANSION FITTINGS FOR RIGID AND PVC CONDUIT
 - .1 Weatherproof expansion fittings with internal bonding assembly, suitable for 4" (100mm) or 8" (200mm) linear expansion, as required.

.2 Watertight expansion fittings with integral bonding jumper suitable for linear expansion, and 3/4" (19mm) deflection in all directions, as required.

.3 O-ring type expansion fittings for PVC conduit.

1.7 INSTALLATION

.1 Install conduits to conserve headroom in exposed locations and cause minimum interference in spaces through which they pass.

.2 Conceal conduits except in mechanical and electrical service rooms.

.3 Use electrical metallic tubing (EMT) except where noted otherwise.

.4 Wiring home runs to panels and main branch wiring runs in ceiling spaces shall be run in conduit. Wiring drops from conduit systems into lighting fixtures and into boxes for wiring devices in steel stud partitions may be wired with AC-90.

.5 Use flexible metal conduit for connection to transformers and equipment subject to movement or vibration. Provide a separate insulated grounding conductor within flexible conduit.

.6 Use watertight flexible metal conduit for connection to motors.

.7 Bend conduit cold. Replace conduit if kinked or flattened more than 1/10th of its original diameter.

.8 Install a minimum # 14 AWG green ground wire in every conduit run.

.9 Install polypropylene fish cord in empty conduits.

.10 Install two 1" (27mm) spare conduits up to ceiling space and two 1" (27mm) spare conduits down to ceiling spaces below from each recessed panelboard, cabinet, annunciator, etc. Terminate these conduits in 6" x 6" x 4" (150 x 150 x 100mm) junction boxes in ceiling space or in case of an exposed concrete slab, terminate each conduit in a flush concrete-type box with extension ring.

.11 Where conduits become blocked, remove and replace blocked section.

.12 Dry conduits out before installing wire.

.13 The length of any conduit run shall not exceed 100' (33m) and no conduit run shall have more than two 90° bends (or equivalent) before a pullbox is installed. Pullboxes shall be installed in accessible ceiling spaces. Conduits shall be supported within 12" (300mm) of entering any junction box, pullbox, cabinet, or panelboard.

.14 Conduit shall be sized as per Canadian Electrical Code or as shown on drawings. Where conductor sizes are increased to suit voltage drop requirements, increase the conduit size to suit at no extra cost.

1.8 SURFACE CONDUITS

.1 Run parallel or perpendicular to building lines.

- .2 Do not locate conduits within 78" (2m) of infrared or gas-fired heaters.
- .3 Group conduits wherever possible on suspended or surface channels.
- .4 Do not locate conduits less than 6" (150mm) from steam or hot water lines.

1.9 CONCEALED CONDUITS

- .1 Do not install conduit home runs horizontally in masonry walls.
- .2 Do not install conduits in terrazzo or concrete toppings.

1.10 CONDUIT IDENTIFICATION

- .1 Colour code with spray paint coverplates of junction boxes in conduit systems as per the colour code list below.
- .2 In addition to colour coding coverplates on junction boxes with power wiring, the circuits being run in the box shall be identified on the inside coverplate with permanent felt marker.

| | <u>Prime</u> | <u>Auxiliary</u> |
|-----------------------|--------------|------------------|
| 120/208V Normal Power | yellow | |
| 347/600V Normal | yellow | green |
| Fire Alarm | red | |
| Telephone | green | white |
| Security | red | yellow |
| Ground | green | |
| PA/Sound | green | blue |
| Controls | blue | |
| Fibre Optic | orange | |

END OF SECTION

1.1 RELATED WORK

- .1 Basic Electrical Material and Methods Section 16050
- .2 Conduits, Conduit Fastenings and Conduit Fittings Section 16111
- .3 Fastenings and Support Section 16126

1.2 MATERIALS

.1 Conductors in Conduit (R-90):

- Type - RW-90
- Conductors - Solid copper #10 AWG and smaller
 - Stranded copper #8 AWG and larger
 - Sized as indicated (minimum #12 AWG)
- Insulation - Cross link polyethylene (XLPE), 90°C (194°F)
- Configuration - Single conductor
- Voltage Rating - 600V

.2 Armoured Cable:

- Type - AC-90
- Conductors - Solid copper #10 AWG and smaller
 - Stranded copper #8 AWG and larger
 - Sized as indicated (minimum #12 AWG)
- Insulation - Cross link polyethylene (XLPE), 90°C (194°F)
- Configuration - Multi conductor, as required, complete with a separate bare CU ground wire.
- Voltage Rating - 600V
- Armour - Bare interlocked aluminum

.3 Non-metallic Sheathed Cable:

- Type - NMD 90 or NMWU-90
- Conductors - Solid copper #10 AWG and smaller
 - Stranded copper #8 AWG and larger
 - Sized as indicated (minimum #12 AWG)
- Insulation - Cross link polyethylene (XLPE), or PVC insulated with Nylon covering, 90°C (194°F)
- Configuration - Multi-conductor, as required, c/w a separate bare copper ground wire.
- Voltage Rating - 300V

1.3 INSTALLATION IN RACEWAYS

.1 Install wiring as follows:

- .1 In conduit systems in accordance with Section 16111.
- .2 Ensure conduits are dry and free of debris before pulling cables.
- .3 Colour coding and identification as per this Section.
- .4 Wires in outlet, junction and switch boxes, not having a connection within the box shall not be spliced, but shall continue unbroken through the box.

1.4 INSTALLATION OF SINGLE CONDUCTOR CABLES

- .1 Single conductor cables damaged shall be installed one cable diameter apart on suspended cable tray or channel supports and shall be clamped with aluminum cable clamps. Cables shall be terminated using non-magnetic connectors. Cable armour shall be grounded via an aluminum plate at the supply end and isolated via an insulating plate, at the load end of the cable. A #3/0 AWG bare (unless otherwise noted) copper ground wire shall be installed with each set of feeder cables. Cable bending radius shall be at least twelve times the overall cable diameter and bend shall not damage or distort the outer sheath.

1.5 INSTALLATION OF FLEXIBLE ARMoured CABLE

- .1 Type AC-90 armoured cable (BX) shall be used for connections from conduit systems to recessed luminaires in accessible ceilings. Cable shall be of sufficient length to allow the lighting fixture to be relocated to any location within a 6' (1,830 mm) radius. Cable shall be clamped before entering the conduit system junction box.
- .2 Type AC-90 armoured cable may be used for connections from conduit systems to wiring devices in steel stud partitions and for interconnection of wiring devices within steel stud partitions, cable shall be clipped before entering junction or outlet boxes. Cable shall be clamped within partitioning with plastic tie-wraps.

1.6 INSTALLATION IN EQUIPMENT

- .1 Group and lace-in neatly, wire and cable installed in switchboards, panelboards, cabinets, wireways and other such enclosures.

1.7 TERMINATIONS

- .1 Terminate wires and cables with appropriate connectors in an approved manner.

1.8 MOTOR CONNECTIONS

- .1 Flexible connections to motors shall not exceed 78" (2 m) unless authorized in writing by Contract Administrator.

1.9 IDENTIFICATION

- .1 Wire in conduit #2 AWG and smaller shall have solid coloured insulation, colour coded as listed below.
- .2 Wire in conduit #1 AWG and larger and single conductor cables for normal power feeders shall be identified at each outlet box and termination with a 6" (150mm) band of coloured

vinyl tape of the appropriate colour. Neutral and ground conductors shall be identified. Paint or other means of colouring the insulation shall not be used.

- .3 Colour code wire in conduit and single conductor cables as follows:
 - Phase A - red
 - Phase B - black
 - Phase C - blue
 - Neutral - white
 - Ground - green
- .4 Maintain phase sequence and colour coding throughout project.
- .5 Use colour coded wires in communication cables, matched throughout system.
- .6 Identify control conductors in motor equipment, contactors, fire alarm panels, etc. with mylar/cloth wire markers.

END OF SECTION

-
- 1.1 RELATED WORK
- .1 Basic Electrical Materials and Methods Section 16050
 - .2 Conduits, Conduit Fastenings and Conduit Fittings Section 16111
 - .3 Wire and Cable Section 16120
- 1.2 SUPPORT CHANNELS
- .1 U-shape, galvanized steel unistrut, size 1.6" x 1.6" (40mm x 40mm), 0.1" (2.5mm) thick, surface-mounted, suspended or set in poured concrete walls and ceilings as required.
- 1.3 MANUFACTURERS
- .1 Acceptable manufacturers: Burndy; Electrovert; Unistrut; Pilgrim; Pursley.
- 1.4 INSTALLATION
- .1 Secure equipment to solid masonry, tile and plaster surfaces with lead anchors.
 - .2 Secure equipment to poured concrete with cast-in or expandable inserts.
 - .3 Secure equipment to hollow masonry walls or suspended ceilings with toggle bolts.
 - .4 Support equipment, conduit or cables on support channels using clips, spring loaded bolts, cable clamps designed as accessories to basic channel members.
 - .5 Fasten exposed conduit or cables to building construction or support system using straps.
 - .1 One-hole steel straps to secure surface conduits and cables 1-1/4" (32mm) and smaller.
 - .2 Two-hole steel straps for conduits and cables larger than 1-1/4" (32mm).
 - .3 Beam clamps to secure conduit to exposed steel Work.
 - .6 Suspended support systems.
 - .1 Support individual cable or conduit runs with 1/4" (6mm) dia. Threaded rods and spring clips.
 - .2 Support 2 or more cables or conduits on channels supported by 3/8" (10mm) diameter threaded rod hangers where direct fastenings to building construction is impractical.
 - .7 For surface-mounting of two or more conduits use channels at 60" (1.52m) o.c.
 - .8 Ensure adequate support for raceways and cables dipped vertically to equipment where there is no wall support.

- .9 Do not use wire lashing or perforated pipe straps to support or secure raceways or cables.
- .10 Do not use supports or equipment installed by other trades for conduit or cable support except when otherwise approved by the Contract Administrator.
- .11 Install fastenings and supports as required for each type of equipment cables and conduits, in accordance with manufacturer's installation recommendations.
- .12 Where conduit and cable runs are installed on support systems, they shall be run so as to be as inconspicuous as possible. Coordinate support system path with equipment, of other trades, to ensure proper installation of electrical equipment. Run support system path perpendicular or parallel to building lines.

END OF SECTION

- 1.1 RELATED WORK
 - .1 Basic Electrical Materials and Methods Section 16050
 - .2 Conduits, Conduit Fastenings and Conduit Fittings Section 16111
 - .3 Fastening and Supports Section 16126
- 1.2 LOCATION
 - .1 Locate splitters, junction and pullboxes as needed for each system.
- 1.3 SPLITTERS
 - .1 Sheet metal enclosure and hinged cover, suitable for locking in closed position.
 - .2 Main and branch lugs, shall match required size and number of incoming and outgoing conductors, as indicated.
- 1.4 JUNCTION AND PULLBOXES
 - .1 Sheet steel construction with screw-on flat covers for surface or recessed mounting.
 - .2 Covers with 1" (25mm) minimum extension all around, for flush-mounted pull and junction boxes.
 - .3 Doors with gasketed covers where exposed to weather.
- 1.5 CABINETS
 - .1 Type E: sheet steel, hinged door and return flange overlapping sides, handles, lock and catch, for surface-mounting.
 - .2 Type T: sheet steel cabinet, with hinged door, latch, lock, 2 keys, containing 3/4" (19mm) GIS fir plywood backboard. Cabinets shall be flush or surface-mounted as indicated.
- 1.6 SPLITTER INSTALLATION
 - .1 Install splitters as indicated and mount plumb, true and square to the building lines.
 - .2 Extend splitters full length of equipment arrangement except where indicated otherwise.
 - .3 Use splitters only where indicated on the drawings.
- 1.7 JUNCTION, PULLBOXES AND CABINETS
 - .1 Install pullboxes in inconspicuous but accessible locations.
 - .2 Mount cabinets with top not higher than 74" (1.9m) above finish floor.
 - .3 Install terminal blocks, as indicated.

- .4 Provide pullboxes in conduit runs as described in Section 16111.
 - .5 Boxes and cabinets shall be installed plumb and square with building lines.
 - .6 Install junction and pullboxes clear of all mechanical ductwork and piping.
 - .7 Junction and pullboxes shall be sized to C.E.C.
- 1.8 IDENTIFICATION
- .1 Identify splitters with Size 5 nameplates.
 - .2 Identify junction and pullboxes with Size 1 nameplates.
 - .3 Identify cabinet with Size 5 nameplates.

END OF SECTION

- 1.1 RELATED WORK
 - .1 Basic Electrical Materials and Methods Section 16050
 - .2 Conduits, Conduit Fastenings and Conduit Fittings Section 16111
- 1.2 SYSTEM DESCRIPTION
 - .1 Provide boxes to suit each specified application. Locate as indicated.
- 1.3 OUTLET AND CONDUIT BOXES - GENERAL
 - .1 Size boxes in accordance with CSA C22.1, Section 12.
 - .2 Gang boxes where wiring devices are grouped.
 - .3 Blank coverplates for boxes without wiring devices.
 - .4 347V outlet boxes for 347V switching devices.
 - .5 Combination boxes with barriers where outlets for more than one system are grouped.
- 1.4 SHEET STEEL OUTLET BOXES
 - .1 Electro-galvanized steel device boxes for flush installation, minimum size 4" (100mm) square with extension and plaster rings in plaster and tile walls as required.
 - .2 Electro-galvanized steel utility boxes for outlets connected to surface-mounted EMT conduit.
 - .3 4" (100mm) square or octagonal outlet boxes for lighting fixture outlets.
- 1.5 MASONRY BOXES
 - .1 Electro-galvanized steel masonry single and multi-gang boxes for devices flush-mounted in exposed block or brick walls.
- 1.6 FITTINGS - GENERAL
 - .1 Bushings and connectors with nylon insulated throats.
 - .2 Knock-out fillers to prevent entry of foreign materials.
 - .3 Conduit outlet bodies for conduit up to 1-1/4" (35mm) and pullboxes for larger conduits.
 - .4 Double locknuts and insulated bushings on sheet metal boxes.
- 1.7 SECTIONAL BOXES
 - .1 Do not utilize sectional boxes.

1.8 INSTALLATION OF BOXES

- .1 Support boxes independently of connecting conduits.
- .2 Fill boxes with paper, sponges or foam or similar approved material to prevent entry of construction material.
- .3 For flush installations, mount outlets flush with finished wall using plaster rings to permit wall finish to come within 1/4" (6mm) of opening.
- .4 Provide correct size of openings in boxes for conduit and cable connections. Reducing washers not allowed.
- .5 Maintain continuity of vapour barrier where boxes are installed in exterior walls. Provide preformed vapour tight poly boxes sized to suit outlet box and caulk with acoustic sealant to building vapour barrier.
- .6 Boxes shall be mounted plumb and square with building lines.
- .7 Coordinate boxes in masonry with brick or block configuration. Boxes shall be sawcut in bottom of appropriate brick or block.
- .8 Coordinate locations with millwork.
- .9 Verify exact location of floor boxes with Contract Administrator. Adjust floor boxes level with finished floor.
- .10 Verify exact location of service fittings with furniture drawings and/or Contract Administrator. Service fittings shall be installed parallel and perpendicular to building lines.

END OF SECTION

1.1 RELATED WORK

- .1 Basic Electrical Materials and Methods Section 16050
- .2 Outlet Boxes and Fittings Section 16134

1.2 SUBMITTALS

- .1 Submit shop drawings and product data in accordance with Section 16050.

1.3 SWITCHES

- .1 Toggle-operated general purpose AC switches 15A and 20A, 120V AC and 347V AC, single pole, double pole, three-way and four-way switches as indicated, with the following features:

- .1 Terminal holes approved for No. 10 AWG wire.
- .2 Silver alloy contacts.
- .3 Urea molding.
- .4 Suitable for back and side wiring.
- .5 Brown or white toggle. Confirm with Contract Administrator.
- .6 Fully rated for tungsten filament and fluorescent lamps, and up to 80% of rated capacity of motor loads.

- .2 Switches of one manufacturer throughout project.

- .3 Switches shall be premium specification grade.

- .4 Acceptable manufacturers:

| <u>Manufacturer</u> | <u>120 Volt</u> | <u>347 Volt</u> |
|---------------------|-----------------|-----------------|
| Hubbell | 1200 Series | 18200 Series |
| Bryant | 4800 Series | 6800 Series |
| Leviton | 1200 Series | 54500 Series |
| Pass & Seymour | 15AC1 Series | 3715 Series |
| Arrow Hart | 1891 Series | 18201 Series |
| Woodhead | 1890 Series | |

1.4 RECEPTACLES

- .1 Duplex receptacles, NEMA No. 5-15R, 125V AC, 15A, U-ground with the following features:

- .1 Nylon face. Confirm colour with Contract Administrator.
- .2 Suitable for No. 10 AWG for back and side wiring.

- .3 Break-off links for use as split receptacles.
- .4 Double wipe contacts and riveted grounding contacts.
- .2 Single receptacles NEMA No. 5-15R, 125V AC, 15A, U-ground, with the following features:
 - .1 Nylon face. Confirm colour with Contract Administrator.
 - .2 Suitable for No. 10 AWG for back and side wiring.
 - .3 Receptacles shall be identified isolated ground type where indicated either by orange colour face or orange triangle. Provide a separate insulated ground wire for each isolated ground circuit.
 - .4 Receptacles shall be of one manufacturer throughout project.
- .3 Acceptable Manufacturers: Hubell; Arrow Hart; Bryant; Woodhead; Pass & Seymour. Catalogue No. 5252 for all manufacturers.
- 1.5 COVERPLATES
 - .1 Coverplates from one manufacturer throughout project.
 - .2 Stainless steel coverplates for wiring devices mounted in flush-mounted outlet boxes.
 - .3 Sheet steel utility box cover for wiring devices installed in surface mounted utility boxes.
- 1.6 INSTALLATION – SWITCHES
 - .1 Install single throw switches with handle in “UP” position when switch closed.
 - .2 Install switches in gang-type outlet box when more than one switch is required in one location.
 - .3 Mount toggle switches at height specified in Section 16050 or as indicated.
- 1.7 INSTALLATION – RECEPTACLES
 - .1 Install receptacles in gang-type outlet box when more than one receptacle is required in one location.
 - .2 Mount receptacles horizontally at height specified in Section 16050, or as indicated.
 - .3 Install cord sets on ranges and dryers.
- 1.8 INSTALLATION – COVERPLATES
 - .1 Install suitable common coverplates where wiring devices are ganged.
 - .2 Do not use coverplates intended for flush outlet boxes on surface mounted boxes.
 - .3 Provide a coverplate on each outlet.

1.9 IDENTIFICATION

- .1 Identify receptacles with 'P' label nameplate indicating panel and circuit number.
Nameplates to be pre-glued with peel-off paper backing.

END OF SECTION

1.1 RELATED WORK

- | | | |
|----|---|----------------|
| .1 | Mechanical Specifications | Division 15000 |
| .2 | Basic Electrical Materials & Methods | Section 16050 |
| .3 | Conduits, Conduit Fastenings and Conduit Fittings | Section 16111 |
| .4 | Wire and Cable | Section 16120 |
| .5 | Outlet Boxes and Fittings | Section 16134 |
| .6 | Motor Starters | Section 16155 |
| .7 | Motor and Circuit Disconnects | Section 16170 |
| .8 | Motor Control Centres | Section 16920 |

1.2 SYSTEM DESCRIPTION

- .1 Provide complete electrical power and control connections for mechanical equipment, except as noted herein, or as noted on the drawings.

1.3 MATERIALS

- .1 Include motor starters, disconnects, conduit, wire, fittings, interlocks, outlet boxes, junction boxes, and all associated equipment required to provide power wiring for mechanical equipment, unless otherwise indicated.
- .2 Include pushbutton stations, motor protective switches, interlocks, conduit, wire, devices, and fittings required to provide control wiring for mechanical equipment, except for temperature/humidity control system.
- .3 Unless otherwise noted, motors and control devices shall be supplied by Division 15. Motor horsepower ratings shall be as shown in the Division 15 specifications. Motor voltage and phase ratings shall be as shown on the Division 16 drawings.

1.4 EXTERIOR EQUIPMENT

- .1 All equipment, mounted on the exterior of the building, shall be weatherproof.

1.5 POWER WIRING

- .1 Install power feeders, starters, disconnects, and associated equipment and make connections to all mechanical equipment.
- .2 Install branch circuit wiring for mechanical system control panels, time clocks, and control transformers.
- .3 Install main power feeders to starter/control panels furnished by Division 15. Install branch wiring from starter/control panels to controlled equipment such as motors, electric coils, etc.

- .4 Conduit, wire, devices and fittings required to wire and connect low voltage temperature control systems, shall be supplied and installed by the trade supplying the temperature control system. Control wiring shall be installed in conduit.

1.6 CO-ORDINATION

- .1 Refer to mechanical drawings for the exact location of motor control devices, and other mechanical equipment requiring an electrical connection.
- .2 Obtain full information from Division 15, regarding wiring controls, overload heaters, equipment ratings and over-current protection. Notify the Division 15, at once, if any information provided is incorrect or unsatisfactory.
- .3 Refer to Division 15 specifications for any further electrical requirements.
- .4 Review both electrical and mechanical drawings and specifications and co-ordinate all controls with Mechanical Subtrades through Contractor. Report all discrepancies to Contract Administrator before close of tender.
No additional money will be justified for assumptions made on any duplication of information.
- .5 Submit to the Contractor a list of controls and wiring to be provided in the Electrical Contract.

END OF SECTION

1.1 RELATED WORK

- .1 Basic Electrical Materials and Methods Section 16050
- .2 Conduits, Conduit Fastenings and Conduit Fittings Section 16111
- .3 Circuit Breakers Section 16182

1.2 SUBMITTALS

- .1 Submit shop drawings in accordance with Section 16050.
- .2 Drawings shall include electrical detail of panel, branch breaker type, quantity, ampacity and enclosure dimension.

1.3 PLANT ASSEMBLY

- .1 Install circuit breakers in panelboards before shipment.
- .2 In addition to CSA requirements, manufacturer's nameplate shall show fault current that panel, including breakers, has been built to withstand.

1.4 PANELBOARDS

- .1 Panelboards: to CSA C22.2 No. 29-M1989.
- .2 CDP panels: to CSA C22.2 No. 29-M1989 and shall be manufactured to allow installation of two 200A frame breakers adjacent to each other – horizontally.
- .3 Panelboards shall be product of one manufacturer throughout project.
- .4 250V branch circuit panelboards: bus and breakers rated for 10 kA symmetrical interrupting capacity minimum or as indicated.
- .5 CDP panelboards: bus and breakers rated for 25 kA symmetrical interrupting capacity, unless otherwise indicated. CDP panels shall be complete with doors.
- .6 Sequence phase bussing such that circuit breakers shall be numbered vertically in consecutive order. Each breaker shall be identified by permanent number identification as to circuit number.
- .7 Panelboards: mains, number of circuits, and number and size of branch circuit breakers as indicated.
- .8 Two keys for each panelboard and key panelboards alike.
- .9 Aluminum bus with full size neutral.
- .10 Flush or surface-mounted tubs as shown.
- .11 Finish trim and door baked grey enamel.

1.5 BREAKERS

- .1 Breakers to Section 16182.
- .2 Breakers with thermal magnetic tripping in panelboards, except as indicated otherwise.
- .3 Main breaker: mounted on top or bottom of panel to suit cable entry.
- .4 Lock-on devices for 5% of 15A branch breakers installed as indicated. Turn over unused lock-on devices to the City.

1.6 EQUIPMENT IDENTIFICATION

- .1 Size 4 nameplate for each panelboard and CDP to indicate panel designation and voltage.
- .2 Size 3 nameplate for each breaker in CDP panelboards engraved to indicate load being supplied.
- .3 Complete circuit directory with typewritten legend showing room number and load of each circuit.

1.7 MANUFACTURERS

- .1 Acceptable manufacturers: CGE, Cutler-Hammer, Schneider Canada, Siemens or to match existing.

1.8 INSTALLATION

- .1 Locate panelboards as indicated and mount securely, plumb, true and square, to adjoining surfaces.
- .2 Install surface-mounted panelboards on U-channels. Where practical, group panelboards on common length of U-channel.
- .3 Mount panelboards to height indicated in Section 16050, unless otherwise indicated.
- .4 Connect loads to circuits as indicated.
- .5 Install spare conduits from recessed panelboards in accordance with Section 16111.
- .6 Connect isolated ground bus in panelboards to main building grounds source or distribution secondary neutral with #2/0 AWG, green insulated ground wire, in conduit.
- .7 Mount panelboard such that the top is 6'-0" (1.83m) finished floor.

END OF SECTION

1.1 RELATED WORK

- .1 Basic Electrical Materials and Methods Section 16050
- .2 Mechanical Equipment Connections Section 16151

1.2 SUBMITTALS

- .1 Submit product data in accordance with Section 16050.

1.3 EQUIPMENT

- .1 Fusible and non-fusible disconnect switches in EEMAC '1' enclosure for interior applications, and EEMAC '3' enclosure for exterior applications, unless otherwise indicated.
- .2 Provision for padlocking in "ON-OFF" position.
- .3 Mechanically interlocked door to prevent opening when handle in "ON" position.
- .4 Fuses as indicated in accordance with Section 16181.
- .5 Fuse holders in each switch suitable without adaptors, for type of fuse, as indicated.
- .6 Quick-make, quick-break action.
- .7 "ON-OFF" switch position indication on switch enclosure cover.
- .8 Single-phase motor disconnect switches shall be one or two-pole toggle-type, 20 amp, 120/227V AC, brown handle with side and back wiring complete with pilot light.
- .9 Three-phase motor disconnect switches for motors up to 5HP at 208V and 10HP at 600V shall be 3-pole, toggle-operated with surface-mounting enclosure, as indicated.
- .10 Three-phase motor disconnect switches for motors above 5HP at 208V or 10HP at 600V shall be 600V non-fusible safety switches, sized as required. Switch shall be non-teasing, quick-make, quick-break type with visible blades, line terminal shield and enclosure, as indicated, with cover interlock and lockable handle.

1.4 EQUIPMENT IDENTIFICATION

- .1 Indicate name of load controlled on Size 4 nameplate to Section 16050.

1.5 MANUFACTURERS

- .1 Acceptable manufacturers: CGE, Cutler-Hammer, Square D, Siemens.

1.6 INSTALLATION

- .1 Install motor disconnect switches where indicated.

- .2 Install fused circuit disconnect switches where indicated or where required by the inspection authorities and/or for equipment supplied by other trades.

END OF SECTION

1.1 RELATED WORK

- .1 Basic Electrical Materials and Methods Section 16050
- .2 Panelboards Section 16160

1.2 SUBMITTALS

- .1 Submit product data in accordance with Section 16050.
- .2 Include with requests for equal, time-current characteristics curves for breakers with ampacity of 800A and over, or with interrupting capacity of 18,000 symmetrical RMS and over at system voltage.

1.3 BREAKERS – GENERAL

- .1 Bolt-on molded case circuit breaker, quick-make, quick-break type, for manual and automatic operation with temperature compensation for 40°C (104°F) ambient.
- .2 Common-trip breakers with single handle for multi-pole applications.
- .3 Magnetic instantaneous trip elements in circuit breakers, to operate only when the value of current reaches setting. Trip settings on breakers with adjustable trips to range from 3-10 times current rating.

1.4 THERMAL MAGNETIC BREAKERS

- .1 Molded case circuit breaker shall operate automatically by means of thermal and magnetic tripping devices to provide inverse time current tripping under overload conditions and instantaneous magnetic tripping for short circuit protection.

1.5 GROUND FAULT CIRCUIT INTERRUPTERS

- .1 Molded case circuit breakers as above with integral Class A Group 1 ground fault interrupter.

1.6 MANUFACTURERS

- .1 Acceptable manufacturers: CGE, Cutler-Hammer, Schneider Canada, Seimens.

1.7 INSTALLATION

- .1 Install circuit breakers as indicated.

END OF SECTION

1.1 RELATED WORK

- | | | |
|----|---|---------------|
| .1 | Basic Electrical Materials and Methods | Section 16050 |
| .2 | Conduits, Conduit Fastenings and Conduit Fittings | Section 16111 |
| .3 | Wire and Cables | Section 16120 |
| .4 | Outlet Boxes and Fittings | Section 16134 |
| .5 | Wiring Devices | Section 16140 |
| .6 | Motor and Circuit Disconnects | Section 16170 |

1.2 SYSTEM DESCRIPTION

- .1 Make all required electrical connections to devices, equipment, appliances, etc., furnished by other trades or City, as indicated or implied on the drawings or in the specifications.
- .2 Provide and install miscellaneous electrical components where required.

1.3 COORDINATION

- .1 Verify electrical supply characteristics of all equipment prior to rough-in. Report any discrepancies immediately. Revise wire sizing, device type, connection type, breaker size, etc., as required, to accommodate the electrical supply characteristics of the equipment supplied by other trades.

1.4 GENERAL

- .1 Provide all required electrical devices, components, conduits, fittings, wiring, disconnects, and miscellaneous equipment to make all connections to equipment.
- .2 Be familiar with the apparatus being supplied and carefully coordinate and cooperate with the supplier/ installer to ensure a proper and complete installation.

1.5 RECEPTACLES

- .1 Where equipment has line cord and plug, ensure cap is compatible with receptacle.
- .2 Provide cordsets to equipment where required.

1.6 EQUIPMENT SUPPLIED BY OTHER TRADES OR CITY

- .1 Wire and connect all equipment requiring an electrical connection. Install disconnect switches where required.
- .2 Provide a direct connection or receptacle and cord set to suit requirements of each piece of equipment. Confirm connection method with the Contract Administrator or Contractor.

END OF SECTION

1.1 RELATED WORK

- .1 Basic Electrical Materials and Methods Section 16050
- .2 Conduits, Conduit Fastenings and Conduit Fittings Section 16111
- .3 Wire and Cable Section 16120

1.2 COORDINATION WITH HYDRO SUPPLY AUTHORITY

- .1 Make all arrangements and coordinate with Hydro supply authority to ensure availability of service when required.
- .2 Submit all required drawings to supply authority for their approval.
- .3 Refer to Contract Administrator for new electrical service by the supply authority.

1.3 COORDINATE WITH TELEPHONE AUTHORITY

- .1 Make all arrangements and coordinate with telephone utility to ensure availability of service when required.
- .2 Refer to Contract Administrator for requirements associated with telephone service by the telephone utility.

1.4 EQUIPMENT

- .1 Conduit and fittings to Section 16111.

1.5 PRIMARY CABLES

- .1 Primary cables to the utility supplied pad mounted transformer or the customer supplied service entrance switchgear to be provided by the Hydro utility.

1.6 SECONDARY CABLES

- .1 Install secondary cables from CSTE to main distribution, via a trench as indicated. Allow adequate conductor length for termination. Backfill trench and restore surface to original condition.
- .2 Arrange for inspection of cables in trench by Contract Administrator BEFORE backfill, or provide and pay for Certificate of Inspection by Utility.

1.7 TELEPHONE ENTRANCE CONDUIT

- .1 Install telephone service entrance conduit from the main telephone terminal board to be stubbed out 3" past the building at roof height complete with service cap.

END OF SECTION

1.1 RELATED WORK

- .1 Basic Electrical Materials and Methods Section 16050
- .2 Conduits, Conduit Fastenings and Conduit Fittings Section 16111
- .3 Wire and Cables Section 16120
- .4 Circuit Breakers Section 16477

1.2 DESCRIPTION OF EQUIPMENT

- .1 Main distribution board incorporates service entrance cable connection section, main breaker section and sub-distribution section, factory assembled in one enclosure.

1.3 SUBMITTALS

- .1 Submit shop drawings and product data in accordance with Section 16050.
- .2 Indicate:
 - .1 Floor anchoring method and foundation template.
 - .2 Dimensioned cable entry and exit locations.
 - .3 Dimensioned position and size of bus.
 - .4 Overall length, height and depth.
 - .5 Dimensioned layout of internal and front panel mounted components.
 - .6 Shipping sections and weights.

1.4 MAINTENANCE DATA

- .1 Provide data for incorporation into Maintenance Manual specified in Section 16050.

1.5 MAINTENANCE MATERIALS

- .1 One set spare parts as recommended by manufacturer.

1.6 MATERIALS

- .1 Service entrance board: to CSA C22.2 No. 31.
- .2 Molded case circuit breakers: to CSA C22.2 No. 5.
- .3 Fuse holder assemblies: to CSA C22.2 No. 39.
- .4 Meters: to CSA C17.

- .5 Meter mounting devices: to CSA C22.2 No. 115.
- .6 Digital instruments: to ANSI C39.1 and UL508.
- .7 Instruments transformers: to CSA C13.
- 1.7 POWER SUPPLY
 - .1 Power supply: 3 phase, 4 wire, grounded neutral, 60 Hz, short circuit current rated at 25 KA RMS symmetrical, voltage as indicated on the drawings.
- 1.8 SERVICE ENTRANCE SWITCHBOARD
 - .1 Ampere rating: as indicated on the drawings.
 - .2 Enclosure:
 - .1 Free-standing, totally enclosed sheet steel, 'sprinklerproof' enclosure with steel frame.
 - .2 Sheet steel barriers to separate adjoining sections.
 - .3 Provision for installation of supply authority metering transformers.
 - .4 Digital customer metering unit.
 - .5 Distribution section.
 - .6 Hinged access panels with captive knurled thumb screws. Utility metering section to have provision for utility seals.
 - .7 High conductivity aluminium bus.
 - .8 Bus from load terminals of main breaker via metering section to main lugs of distribution section.
 - .9 Identify phases with color coding.
- 1.9 MAIN BREAKER SECTION
 - .1 The main circuit breaker shall be a manually operable, fixed mounted molded case circuit breaker.
- 1.10 GROUNDING
 - .1 Copper ground bus extending full width of cubicles and located at bottom.
 - .2 Lugs at each end sized for grounding cable.
 - .3 Bond non-current carrying metal parts to ground bus.

1.11 HYDRO UTILITY METERING SECTION

- .1 Separate compartment for exclusive use of utility company metering transformers.
- .2 Provide mounting and wiring for the following:
 - .1 potential transformers.
 - .2 current transformers.
- .3 Hydro utility metering transformers to be supplied by the Hydro utility and factory installed by the switchboard manufacturer.

1.12 DISTRIBUTION SECTION

- .1 The distribution section to consist of a CDP type panelboard with molded case circuit breakers. Each breaker shall be manually operated, fixed type with trip ratings as shown on the drawings. Minimum interrupting rating to be 42,000 amps symmetrical.

1.13 FINISHES

- .1 Apply finishes in accordance with Section 16050:
 - .1 services entrance switchboard finish to be interior gray
 - .2 supply 2 spray cans of touch-up enamel
 - .3 treated to inhibit rusting

1.14 EQUIPMENT IDENTIFICATION

- .1 Provide equipment identification in accordance with Section 16050.
- .2 Nameplates:
 - .1 black plate, white letters, size 7, to indicate voltage, amp rating and designation
 - .2 complete switchboard: labelled as above, main disconnect: labelled "Main Breaker"
 - .3 sub-breakers: labelled to indicate panel or equipment fed

1.15 SHOP FABRICATION

- .1 Assemble and wire complete service entrance board.
- .2 Energize switchboard.
- .3 Prepare switchboard for shipment to site.

1.16 MANUFACTURERS

- .1 Acceptable manufacturers: Cutler-Hammer, Schneider Electric, General Electric, Siemens.

1.17 INSTALLATION

- .1 Locate service entrance switchboard as indicated.
- .2 Connect main secondary service entrance cables to line terminals of switchboard.
- .3 Connect load terminals of distribution breakers to outgoing feeders, as indicated.
- .4 Check factory-made connections for mechanical security and electrical continuity.
- .5 Run one #3 /0, bare copper, grounding conductor in 1" (25mm) conduit from ground bus to the main building ground.
- .6 Check relay settings against shop drawings to ensure proper working and protection of components.
- .7 Manufacturer to provide test equipment and field test overload, magnetic and ground fault tripping. Include test report in Maintenance Manuals.
- .8 Arrange for main distribution switchboard to be mounted on 4" (100mm) housekeeping pad.

END OF SECTION

1.1 RELATED WORK

- .1 Basic Electrical Materials and Methods Section 16050
- .2 Mechanical Equipment Connections Section 16151

1.2 SUBMITTALS

- .1 Submit product data in accordance with Section 16050.

1.3 EQUIPMENT

- .1 Fusible disconnect switches in EEMAC '1' enclosure for interior applications, and EEMAC '3' enclosure for exterior applications, unless otherwise indicated.
- .2 Provision for padlocking in "ON-OFF" position.
- .3 Mechanically interlocked door to prevent opening when handle in "ON" position.
- .4 Fuses as indicated in accordance with Section 16181.
- .5 Fuseholders in each switch suitable without adaptors, for type of fuse, as indicated.
- .6 Quick-make, quick-break action.
- .7 "ON-OFF" switch position indication on switch enclosure cover.

1.4 EQUIPMENT IDENTIFICATION

- .1 Indicate name of load controlled on Size 4 nameplate to Section 16050.

1.5 MANUFACTURERS

- .1 Acceptable manufacturers: Cutler-Hammer, Schneider, Square D, Siemens.

1.6 INSTALLATION

- .1 Install motor disconnect switches where indicated.
- .2 Install fused circuit disconnect switches where indicated or where required by the inspection authorities and/or for equipment supplied by other trades.

END OF SECTION

1.1 RELATED WORK

- .1 Basic Electrical Material and Methods Section 16050
- .2 Wire and Cable Section 16120
- .3 Main Distribution Switchboard Section 16421

1.2 REFERENCES

- .1 Ground equipment to: CSA C22.2 No. 41.
- .2 Copper grounding conductors to: CSA G7.1

1.3 EQUIPMENT

- .1 Grounding conductors system, circuit and equipment, grounding to be bare stranded copper, sized in accordance with the Canadian Electrical Code.
- .2 Non-corroding accessories necessary for grounding system, type, size, material as indicated, including but not necessarily limited to:
 - .1 grounding and bonding bushings
 - .2 protective type clamps
 - .3 bolted type conductor connectors
 - .4 thermit welded type conductor connectors
 - .5 bonding jumpers, straps
 - .6 pressure wire connectors

1.4 INSTALLATION GENERAL

- .1 Install complete permanent, continuous, system and circuit, grounding systems including electrodes, conductors, connectors and accessories to conform to requirements of local authority having jurisdiction over installation.
- .2 Install connectors to manufacturer's instructions.
- .3 Protect exposed grounding conductors from mechanical injury.
- .4 Make buried connections using copper welding by thermit process.
- .5 Use mechanical connectors for grounding connections to equipment provided with lugs. Soldered joints not permitted.
- .6 Make grounding connections in radial configuration only, with connections terminating at single grounding point. Avoid loop connections.

- .7 Bond single conductor, metallic armoured cables to cabinet at supply end, and provide non-metallic entry plate at load end and run separate ground conductor.
- .8 Provide separate ground conductors in all conduits and raceways.
- 1.5 SYSTEM AND CIRCUIT GROUNDING
 - .1 Install system and circuit grounding connections to neutral points of 600v and 208v systems.
- 1.6 EQUIPMENT GROUNDING
 - .1 Install grounding connections to typical equipment included in, but not necessarily limited to: service equipment, transformers, frame of motors, motor control centres, starters, control panels, building steelwork, generators, elevators distribution panels, outdoor lighting.
- 1.7 COMMUNICATION SYSTEMS
 - .1 Install grounding connections for telephone, sound, fire alarm, intercommunication systems as follows:
 - .1 Provide minimum #6 AWG ground from voice/data rooms to main building ground as indicated.
 - .2 Sound, fire alarm intercommunication system, as indicated, required by manufacturer.
- 1.8 TESTS
 - .1 Perform tests in accordance with Section 16050.
 - .2 Perform ground continuity and resistance tests using method appropriate to site conditions and to approval of the local inspection authority. A report shall be submitted to the Contract Administrator from the testing agency.
 - .3 Perform tests before energizing electrical system.

END OF SECTION

1.1 RELATED WORK

- .1 Concrete Bases Section 03300
- .2 Basic Electrical Materials and Methods Section 16050
- .3 Fastenings and Supports Section 16126
- .4 Outlet Boxes Section 16134

1.2 SUBMITTALS

- .1 Submit shop drawings and product data in accordance with Section 16050.
- .2 Submit complete photometric data prepared by independent testing laboratory for luminaires where specified for approval by Contract Administrator.
- .3 Submit list of replacement lamp data for each luminaire. Include lamp type, voltage, wattage, base type and order code. Include list in maintenance manual.

1.3 GUARANTEE

- .1 Replace:
 - .1 Incandescent and tungsten halogen lamps burnt out within 3 months of takeover.
 - .2 Fluorescent and HID lamps burning out within 12 months of takeover.
 - .3 Ballasts that fail or exceed their labelled noise level rating within 12 months of takeover.

1.4 COORDINATION

- .1 Coordinate luminaire locations with Work of other trades.
- .2 Coordinate luminaire types with ceiling finishes to ensure compatibility.

1.5 GENERAL

- .1 Luminaires shall carry the CSA label.
- .2 Provide supporting devices, plaster frames, junction boxes and outlet boxes where required.
- .3 Provide lenses or diffusers of glass or acrylic materials as indicated. Acrylic lenses used with fluorescent luminaires shall be a minimum of .125" (3 mm) thick.
- .4 Include finishes to Section 16050 and as indicated.
- .5 Where soffits or ceilings have thermal insulation, provide fixtures which are CSA approved for such use.
- .6 Conduct lamp burn in procedures as per manufacture recommendations.

1.6 LAMPS

- .1 Provide lamps as indicated.
- .2 Incandescent lamps shall be extended service type rated 2500 hours, 130 volts, inside frosted, unless indicated otherwise.
- .3 Fluorescent lamps shall be rapid start, T8 2900 lumens, rated 20,000 hours, 3500°K, unless otherwise indicated.

1.7 BALLASTS AND ACCESSORIES

- .1 Provide ballasts and accessories as indicated.
- .2 Provide ballasts with non-PCB type capacitors with pressure sensitive devices to prevent rupturing.
- .3 Provide fluorescent ballasts of 120 and 347V design, automatic reset thermal protected, 90% power factor, group A noise rating. Ballasts shall be premium electronic type to meet Manitoba Hydro Power Smart requirements.
- .4 Ballasts used in exterior luminaires shall be rated at -30°C (-20°F) starting.

1.8 INSTALLATION (LUMINAIRES)

- .1 Install luminaires at locations indicated, complete with all wiring, connections, fittings, hangers, aligners, box covers and accessories, as required.
- .2 Install luminaires and lens materials in architectural details, as indicated.
- .3 Install luminaires parallel with building lines. Wall-mounted luminaires shall be installed plumb.
- .4 Review all ceiling type, construction details and mounting arrangements before placing luminaire orders and ensure that all mounting assemblies, frames, rings and similar features are included for and match the required installation.
- .5 All luminaires and assemblies shall be properly secured and supported. Support luminaires independent of the ceiling construction, complete with all fasteners, framing and hangers, as may be required. Do not secure luminaires to mechanical ductwork or other vibration producing apparatus, unless specifically detailed on the drawings.
- .6 Where a luminaire is suspended from the ceiling using a self-aligning box cover, an additional ground wire from the outlet box to the luminaire shall be provided.
- .7 Coordinate the installation of luminaires with the Work of other trades, ensuring that the necessary depths and mounting spaces are provided. Luminaires which cannot be installed due to a conflict with structural members, pipes or ductwork shall be relocated to a more suitable location, as directed by the Contract Administrator.

1.9 WIRING

- .1 Connect luminaires to lighting circuits as indicated.

1.10 LAMPS

- .1 Adjust lamp position in adjustable lamp holder-type luminaires to produce the proper beam distribution for the specified lamp.

1.11 TESTS

- .1 Perform tests in accordance with Section 16050.
- .2 Check luminaires and replace defective lamps, ballasts, lenses and accessories.

1.12 CLEANING

- .1 Prior to take-over of the project, clean the lenses and reflectors of all luminaires with a damp cloth to remove dust, smudges and fingerprints.

END OF SECTION

1.1 RELATED WORK SPECIFICATIONS

- .1 Electrical General Requirements Section 16010
- .2 Lighting Equipment Section 16500

1.2 PRODUCT DATA

- .1 Submit product data in accordance with Section 16010.

1.3 EXIT LIGHTS

- .1 Housing: 2.0mm thick cast aluminum frame with white enamel finish.
- .2 Face and back plates: cast aluminum alloy. Face plates shall have brushed aluminum finish.
- .3 Light source: LED type.
- .4 Designed for minimum 50,000h of continuous operation without relamping.
- .5 Letters: 150mm high x 19 mm wide, red on die-cast aluminum face plate, reading exit. Exit legend shall conform to CSA C860 standard.
- .6 Downlight: not required. Supply solid base to Exit.
- .7 AC input: the unit shall be capable of operating on 120 V or 347 V/AC input.
- .8 DC operation:
 - .1 The exit shall be provided with circuitry capable of operating on an emergency input of 6, 12 or 24 volts DC. The illumination provided under emergency conditions shall meet the requirements of CSA C860.
 - .2 The Exit shall operate on AC and DC circuits.
- .9 Face plate to remain captive for relamping.
- .10 Units complete with mounting canopies as required.
- .11 The signs shall be approved in compliance with CSA standard C860.

1.4 INSTALLATION

- .1 Install exit lights as indicated, in accordance with NBC-1990.
- .2 Connect fixtures to exit light circuits and battery bank circuits as indicated.
- .3 Ensure that exit light circuit breaker is locked in on position.

END OF SECTION

1.1 RELATED WORK

- .1 Basic Electrical Materials and Methods Section 16050
- .2 Conduits, Conduit Fastenings and Conduit Fittings Section 16111
- .3 Wire and Cable Section 16120
- .4 Outlet Boxes and Fittings Section 16134

1.2 SUBMITTALS

- .1 Submit shop drawings in accordance with Section 16050.
- .2 Data shall indicate system components, mounting method, source of power and special attachments.

1.3 OPERATION AND MAINTENANCE DATA

- .1 Provide data for incorporation into Maintenance Manual specified in Section 16050.
- .2 Operation and Maintenance Manual shall include:
 - .1 Operation and maintenance instructions for complete battery system to permit effective operation and maintenance.
 - .2 Technical data – illustrated parts lists with parts catalogue numbers.
 - .3 Copy of approved shop drawings.

1.4 MAINTENANCE MANUALS

- .1 Provide maintenance manuals in accordance with Section 16050.
- .2 Include:
 - .1 Five spare lamps for remote heads.

1.5 WARRANTY

- .1 Provide a written guarantee, stating that the battery for emergency lighting is guaranteed against defects in material and workmanship for a period of ten years, with a no-charge replacement during the first five years and a pro-rate charge on the second five years from the date of the Final Acceptance from the City.

1.6 SYSTEM DESCRIPTION

- .1 Supply voltage: 120V or 347 V AC as indicated.
- .2 Output voltage: 12V or 24V DC

- .3 Battery: long life sealed lead, maintenance-free.
- .4 Charger: solid state, multi-rate, voltage/current regulated, inverse temperature compensated, short circuit protected, modular constructed.
- .5 Solid state transfer.
- .6 Low voltage disconnect: solid state, modular, operates at 80% battery output voltage.
- .7 Signal lights: solid state, life expectancy 100,000 h minimum, for "AC Power ON" and "High Charge".
- .8 Lamp heads: integral on unit and remote as indicated. Adjustable mounting, swivel type, complete with tungsten-halogen lamp.
- .9 Cabinet: suitable for shelf mounting to wall and complete with knockouts for conduit.
- .10 Auxiliary equipment:
 - .1 test switch
 - .2 battery disconnect device
 - .3 AC input and DC output terminal blocks inside cabinet
 - .4 shelf
 - .5 cord and plug connection for AC
 - .6 RFI suppressors
- 1.7 REMOTE HEADS
 - .1 Lamp heads: 360° horizontal and 180° vertical adjustment.
 - .2 Lamps: 12W, quartz halogen.
 - .3 Enclosure: square, surface mounted, frosted vandal-resistant, lexan cube diffuser, single or double units as indicated.
 - .4 Enclosure: square, surface mounted, clear polycarbonate cover, single or double units as indicated.
- 1.8 INSTALLATION
 - .1 Install unit equipment for emergency lighting in accordance with latest CSA document.
 - .2 Install conduit and wiring as indicated.
 - .3 Install unit equipment and remote mounted fixtures as indicated.
 - .4 Cut and re-cap cord to remove surplus.

- .5 Direct heads as indicated.
- .6 Mount double remote heads on outlet box such that the two heads will be horizontal with the building lines.
- .7 Wire and connect in the exit lights, so equipped, to the battery system as indicated.
- .8 Charge the batteries and test the system for proper operation (minimum of 35 minutes discharge time).

END OF SECTION

1.1 DESCRIPTION OF SYSTEM

- .1 The system shall be a microprocessor based, single stage, addressable fire alarm system. All equipment shall be supplied by one manufacturer and shall be manufactured to ISO 9001 standards.
- .2 The system shall include:
 - .1 Control panel to carry out fire alarm and protection functions including receiving alarm signals, initiating a general alarm, supervising the system continuously, annunciating alarms and initiating trouble signals.
 - .2 Addressable manual alarm stations.
 - .3 Addressable and non-addressable automatic alarm initiating devices.
 - .4 Addressable input and output modules.
 - .5 Audible and visual signals.
 - .6 End of line resistors.
 - .7 Alpha-numeric annunciator.

1.2 OPERATION

- .1 The system shall be a single stage system. Operation of any alarm initiating device shall:
 - .1 Display the event type, alarm time and location message at the fire alarm control panel (and remote alpha-numeric annunciator).
 - .2 Cause all audible signals to sound at a temporal rate.
 - .3 Cause all visual signals to flash in a synchronized manner.
 - .4 Cause designated ventilating fans to shut down.
 - .5 Cause all fire and smoke doors to close automatically if normally held open.
 - .6 Cause all elevators to home to the ground floor.
 - .7 Transmit an alarm signal to a remote monitoring agency.
- .2 Operation of any supervisory initiating device shall:
 - .1 Display a location message at the fire alarm control panel.
 - .2 Display a distinct message to indicate device operation, shall not be combined with the indication of a wiring fault on that circuit.
 - .3 Cause an integral signal to sound at the control panel and remote annunciators.

1.3 MATERIALS

.1 Materials and devices shall be supplied by a single manufacturer and shall be ULC listed as follows:

- .1 Power supply: to CAN/ULC-S527-M87
- .2 Audible signal devices: to CAN/ULC-S525-1978
- .3 Visual signal devices: to CAN/ULC-S526-M87
- .4 Control unit: to CAN/ULC-S527-M87
- .5 Manual fire alarm stations: to CAN/ULC-S528-M91
- .6 Heat detectors: to CAN/ULC-S530-M91
- .7 Smoke detectors: to CAN/ULC-S529-M87

1.4 CONTROL PANEL

.1 The control panel shall be a microprocessor based panel complete with:

- .1 Two (2) class "A" addressable data circuits. Each circuit shall have the capability of controlling up to 96 analog addressable heat or smoke detectors, and up to 94 input or output modules. Addressable data circuits shall not require the use of twisted or shielded wires in normal applications. Addressable data circuit shall have capacity for a minimum of 10% spare capacity for any type of addressable device.
- .2 Three (3) class "B" audible/visual signal circuits, each rated for 2 amps at 24 Vdc. Additional signals circuits, if required: shall utilize panel mounted signal riser modules.
- .3 CPU shall store all basic system functionally and job specific data in non-volatile memory; and shall be fully field programmable via laptop.
- .4 LCD display module with a 4 line by 20 character backlit Liquid Crystal Display. In the alarm mode display total number of unacknowledged events and the type of event on display. Reserve 40 characters of display space for custom messages. To include Back and Next/Ack display control switches.
- .5 Provide LED indicators for the following common control functions: AC Power, alarm, supervisory, monitor, trouble, disable, ground fault, CPU fail, and test.
- .6 Provide common control keys (pushbuttons) and LEDs for reset, alarm silence, trouble silence, drill, and one custom programmable key/indicator.
- .7 Provide a common alarm and common trouble contact for Central Station connection and make connection via monitoring agency.
- .8 Power supply and battery sized sufficiently to provide 24 hours of standby power followed by 30 minutes of continuous alarm.

1.5 ANNUNCIATORS

- .1 Flush mounted, alpha-numeric annunciator with a 4 line by 20 character backlit Liquid Crystal Display, to display all alarm zones. To include Back and Next/Ack display control switches; and display LEDs for Normal, Alarm, Supervisory and Trouble. Include pushbuttons controls for Alarm Silence, Trouble Silence, and Reset and Drill.
- .2 Plexiglass cover complete with key lock shall be provided when the annunciator is located in a public area or corridor.

1.6 MANUAL STATIONS

- .1 Analog addressable manual stations, single stage, pull lever, single action. Where surface mounted, use a surface wallbox.

1.7 DETECTORS

- .1 Analog addressable heat detector, combination fixed temperature/rate of rise heat detector, rated for 70 foot spacing. Detector shall be complete with a green polling LED and a red alarm LED. Detector to mount on a standard, isolator, or relay base; as indicated.
- .2 Analog addressable heat detector, 57°C fixed temperature heat detector, rated for 70 foot spacing. Detector shall be complete with a green polling LED and a red alarm LED. Detector to mount a standard, isolator, or relay base; as indicated.
- .3 Heat detector; 88°C fixed temperature heat detector, rated for 50 foot spacing. Detector shall be wired to an addressable input module via a supervised class "B" circuit.
- .4 Analog addressable type smoke detector, complete with a green polling LED and a red alarm LED. Detector to combine ionization, photo-electric and heat sensors for maximum sensitivity and stability. Detector to have automatic environmental compensation, day/night sensitivity adjustment, and dirty warning indication. Detector to mount on a standard, isolator, or relay base; as indicated.
- .5 Analog addressable photoelectric type detector, complete with a green polling LED and a red alarm LED. Detector to have automatic environmental compensation, day/night sensitivity adjustment, and dirty warning indication. Detector to mount on a standard, isolator, or relay base; and be housed in a duct housing. Provide the appropriate length sampling tubes as required.

1.8 ADDRESSABLE MODULES

- .1 Addressable input module complete with a supervised class "B" input circuit to monitor non-addressable contact devices. Module to include a green polling LED and a red alarm LED.
- .2 Addressable flow/tamper module with a supervised class "B" alarm input for sprinkler flow and a supervised class "B" supervisory input for sprinkler tamper. Module to include a green polling LED and a red alarm LED.
- .3 Addressable relay complete with a form "C" dry relay contact rated 0.5 amps at 120 VAC. Module to include a green polling LED and a red alarm LED.

- .4 Addressable isolator module. Module to isolate short circuits within floor areas exceeding 2,000 square meters and between floors so that a fault within one floor area shall not affect another floor area.
- 1.9 AUDIBLE DEVICES
- .1 Horn strobe with a peak output of 103 dBA at 3 meters, complete with a synchronized strobe with an output of 15 candela. Horn to be field selected for a temporal output. White finish.
 - .2 Mini-horn with a peak output of 90dBA at 3 meters, complete with a 10-minute signal silence. Mini-horn to resound if an alarm condition is still present after 10 minutes. Mini-horn to be fed from a separate signal circuit to provide a temporal output and wired within the suite in a non-supervised manner. White finish.
- 1.10 END OF LINE RESISTORS
- .1 End of line resistor complete with a white plastic single gang cover plate.
- 1.11 SYSTEM PROGRAMMING
- .1 The system shall be fully programmable in the field with the need for special tools and shall not require field replacement of electronic integrated circuits. Systems that require factory burning of e-proms will not be accepted.
 - .2 All programming to be performed via the control panel keypad or a lap-top computer.
 - .3 All field programming to be stored in non-volatile memory.
 - .4 The system programming shall have 2 levels of password protection. The first level shall be used for accessing system controls such as disabling devices and accessing history logs. The second level shall access system programming functions.
 - .5 Any system output, control module or riser module may be programmed to activate on any single input or any combination of inputs.
 - .6 Final system programming shall be performed during the construction period. System installer to provide a detailed list of zone and device designations to the electrical Contract Administrator prior to completing the final system programming.
 - .7 The system shall be fully programmed and operational prior to the commencement of the verification inspection.
- 1.12 APPROVED MANUFACTURERS
- .1 Edwards
 - .2 Simplex
 - .3 Notifier
 - .4 Siemens Cerberus

1.13 INSTALLATION - GENERAL

- .1 Locate, install, wire and connect all components and devices in accordance with the requirements of the manufacturer and ULC S524.

1.14 MOUNTING OF EQUIPMENT

- .1 Mount equipment at heights as described in Section 16050.
- .2 Mount equipment square and plumb with building lines. Install devices flush and square with finished surfaces.

1.15 IDENTIFICATION

- .1 Identify equipment as per Section 16050.
- .2 Clearly identify zone on control panels, devices, etc.
- .3 Identify wires and cables with wire markers to indicate box circuit numbers and terminals, signal circuit numbers and terminals, annunciator wiring. Identify wiring in each box, panel, cabinet, etc. Coding of identification to meet with the approval of the Contract Administrator.

1.16 MISCELLANEOUS DEVICES

- .1 Wire and connect combination door closer and holder devices.
- .2 Wire and connect to Fire Department interface in telephone room.
- .3 Wire and connect fan shutdown interlocks as indicated.

1.17 TESTING

- .1 Conduct tests as per Section 16050.
- .2 The complete system shall be tested and verified in accordance with CAN 4-S537-82, "Standard for the Verification of Fire Alarm System Installations". The manufacturer shall conduct all testing and provide necessary technical personnel. The Contractor to provide necessary technical personnel. The Contractor to provide necessary manpower to facilitate testing.
- .3 The manufacture shall conduct an overall examination of the system installation for the following:
 - .1 The type of equipment installed is that designated by the Contract Administrator's specifications.
 - .2 The wiring connections to all equipment components show that the installer undertook to have observed ULC and CSA requirements.
 - .3 Equipment has been installed in accordance with the manufacturer's recommendations and that all signalling devices are operable.

- .4 The supervisory components are operating and that regulations governing such supervisory wiring have been met to the satisfaction of the Inspection Authorities.
 - .4 The complete system shall be tested in the presence of the Contract Administrator, City's representative, and the local inspection Authorities, on completion of the Verification. Tests shall demonstrate that the fire alarm system will function in an acceptable manner. The Electrical inspector shall be the final authority in determining the acceptable manner of operation.
 - .5 Include all costs for setting up and testing the fire alarm system as directed by the Contract Administrator.
 - .6 Include for zone identification floor plan at main control panel. Floor plan to be CADD derived and be plasticized.
- 1.18 VERIFICATION CERTIFICATE
- .1 On completion of the testing, submit to the Contract Administrator, a Test Report certified by both the manufacturer and Contractor including:
 - .1 A copy of the inspecting Technician's report showing location of each device and certifying the test results of each device.
 - .2 A Certificate of Verification confirming that the Inspection has been completed and showing the conditions upon which such Inspection and Certification have been rendered.
 - .3 Proof of Liability Insurance for the Inspection.

END OF SECTION

- 1.1 RELATED WORK
 - .1 Basic Electrical Materials and Methods Section 16050
- 1.2 CODES AND STANDARDS
 - .1 CAN/CSA-T529 (Electrical Installations)
 - .2 CAN/CSA-T528 (Wiring Systems Administration)
 - .3 CAN/CSA-T530 (Telecommunication Pathways and Spaces)
 - .4 IEEE Std. 1100 (Powering and Grounding Sensitive Electronic Equipment)
 - .5 EIA/TIA, IEEE, FCC Standards (Data System Performance Standards)
 - .6 Manitoba Building Codes (Fire Ratings, Wall Penetration, etc.)
 - .7 CAN/CSA C22.1 Section 60
- 1.3 CONTRACTOR QUALIFICATIONS
 - .1 Only experienced Data Installation Contractors shall be considered for the Work. Contractors must be able to provide evidence of having performed Work of a similar type as specified.
 - .2 Contractor shall be trained and authorized by the manufacturers they represent. All bidders shall provide evidence of their certification, upon request by the Contract Administrator.
 - .3 Contractor shall own and maintain tools and test equipment necessary for the successful installation and testing of the Enhanced Cat. 5 communications cabling system.
 - .4 All personnel employed in the installation of these systems shall be adequately trained in the use of such equipment and testers.
- 1.4 100 MB/S STANDARD
 - .1 All wiring, components and installation procedures shall be approved for and capable of, supporting data transmission rates of a minimum - 100 Mbps.
- 1.5 EQUIPMENT LIST
 - .1 Prepare a printed form listing the various materials as well as the manufacturer's name, catalogue numbers, if any, and the suppliers name.
 - .2 The above list shall be submitted to the Contract Administrator. Manufacturers and suppliers listed shall be those used in Form J :Subcontractors List and whose products used to execute the respective Contract Work.
 - .3 Any and all sub-trades used to assist in the completion of this Work shall be identified on Form J: Subcontractor List.

1.6 MATERIALS

- .1 Cabling: Unshielded Twisted Pairs. Generally, the U.T.P. Media specifications contained in this section reflect the physical characteristics consistent with the UTP media, commonly known as Enhanced Category 5. The industry standard IEEE 802.3 100 BaseT will apply.
- .2 Construction: Eight single, solid conductors, 24 gauge (AWG), 100% fluorinated ethylene propylene (FEP) insulated, formed into 4 individually twisted pairs and enclosed by an overall plenum-rated jacket (FT6). Cable construction to be determined by the manufacturer to ensure compliance with the cross-talk requirements of the above standard.
- .3 Polarization: Generally arranged in compliance with Standard CSA-T529A. Each of eight (8) conductors, when used in conjunction with RJ45 modular plugs, or their corresponding jacks, shall be arranged in accordance with the following table:

| <u>Conductor ID</u> | <u>Pin ID</u> | <u>Colour Code</u> |
|---------------------|---------------|--------------------|
| Pair 1 | 5 | White/Blue (T) |
| Pair 1 | 4 | Blue/White (T) |
| Pair 2 | 3 | White/Orange (T) |
| Pair 2 | 6 | Orange/White (T) |
| Pair 3 | 1 | White/Green (T) |
| Pair 3 | 2 | Green/White (T) |
| Pair 4 | 7 | White/Brown (T) |
| Pair 4 | 8 | Brown/White (T) |

(T) denotes coloured tracer for identification.

- .4 Cable Characteristics:

| | |
|-------------------|------------------------------------|
| Impedance | 100 ohm \pm from 1 to 155 MHz |
| ACR | 15 db at 100 MHz, 10 db at 155 MHz |
| Propagation delay | 5.7 ns/m at 100 MHz, max. |
| Delay Skew | 25 ns at 100M max. |
- .5 Performance: Category 5 (enhanced) cable performance is intended for high speed LAN applications (\geq 155 Mbps). Category 5 cables meet the electrical and corresponding distance requirements of the Commercial Building Standard Specification (CSA529M) for horizontal UTP cables. This specification places limits on the horizontal distances to assure minimum boundaries of performance. The cable run from the communications closet to the Work area outlet is limited to 90 metres. An additional 3 metres is allowed from the outlet to the terminal and 6 metres allowance for patching on the cabinet patch panel to hub equipment.
- .6 Wire Management Panels: Patch panel assemblies utilizing Insulation Displacement Connection (IDC) type terminals will be arranged at key central locations. These panels will be grouped and identified in such a manner as to provide the Client with the greatest degree of flexibility in the organization of the Network Field.

Floor mounted rack complete with the following as standard equipment:

- .1 Bottom and top arranged for cable entry option.

- .2 1-ground lug.
- .3 24 port preassembled patch panels. Manufacturer will be as noted on the Tenders Equipment List.
- .4 25-rack mounting clips and screws.
- .5 Horizontal wire management as shown on detail.
- .6 Rear wire management to allow access to each termination on the patch panel.
- .7 Modular Patch Cords: (Server Room) Four twisted pair Category 5 (enhanced) type stranded cable complete with RJ45 non-keyed modular plugs wired to the configuration indicated under "Polarization" previously shown. Length of cord - 2 metres for wall mounted enclosures and 3 metres long for floor mounted racks. Cords are required to be equipped with strain relief boots over the jacks.
- .8 Modular Line Cords: (Workstation) As detailed above for patch cords. Length of cord - 3 metres.
- .9 Communications Outlet Assemblies: Outlet assemblies at each station identified on drawings shall contain Keystone type modular 8-wire jack (RJ45 type). This outlet shall be coloured orange for Data System use. This assembly shall be mounted as a wall outlet complete with the associated (3 gang) face plate. The keystone jack shall be suitable for wiring with 24 AWG solid conductors, each contact surface shall have a minimum of 50 microinches hard gold; minimum contact force of 100 grams. Conductors separated and aligned internally by jack comb. Polarization is as previously indicated.
- .10 Connector Performance: All equipment used to terminate horizontal data wiring in data station fields shall be required to comply with the same transmission performance criteria set forth for RJ45 jack in communication outlet assemblies. The specific criteria are as follows:
 - .1 RJ45 Pair to Pair crosstalk: Minimum loss of 40 db at a frequency of 100 MHz.
 - .2 RJ45 Insertion Loss (Attenuation): Maximum loss of 0.4 db at a frequency of 100 MHz.

1.7 INSTALLATION

- .1 Supply and install all data lines and associated terminal equipment as previously specified.
- .2 Ensure that all plenum cabling is kept clear of all power equipment and lighting fixtures.

Installation Guidelines

- Transformers = > 2m
- Power Lines (120V Systems) = > 300mm
- Fluorescent Lighting = > 300mm
- Power Lines (600V Systems) = > 1M
- Electrical Motors = > 1M

- .3 Identify all cables with numbered markers at both ends. Transfer identity number on to mark-up drawing for record purposes.
- .4 Ensure that all equipment is constructed to the Standards specified above. All like materials shall be by a single manufacturer.
- .5 No splicing, tapping or bridging devices will be used between specified connecting hardware and outlet assemblies.
- .6 Cabling should be installed over corridor areas and/or along lines parallel to building structures. Penetrations through full-height wall partitions should be made through pre-established horizontal openings or sleeves.
- .7 Cabling installed in ceiling plenum or crawlspaces shall be installed in a clip wireway as on detailed sheet attached. Support by cable ties to existing structures will only be approved by written consent of the Contract Administrator.
- .8 All cable installations shall be protected from mechanical damage.
- .9 Cable should be free from tension over the entire length of each run.
- .10 Cable installation and termination methods shall be completed in a manner that will not degrade the cable specification. All I.D.C. terminations shall be inserted by the use of the proper tool. Use of the "dust cap" to effect insertion will not be considered adequate. Bundling, supporting, stripping of outer jacket, and retention of wiring twist will be subject to the final approval of the Contract Administrator. Work not meeting the above criteria will be re-done.
- .11 All cables shall be labelled generally as indicated on drawings and shall adhere to CSA-T528 standard.
- .12 All fire separation penetrations shall be fire stopped in compliance with Manitoba Building Code and NFPA regulations.
- .13 Floor or wall penetrations that require to be fire rated shall use approved size conduit sleeves complete with insulated grommets.
- .14 All conduit ends, including vertical stubs in wall cavities, shall be fitted with insulated grommets.
- .15 Where the use of concealed or surface conduit shall be used a minimum box size for data/voice termination shall be 4 x 4 x 2-1/4 inches, complete with either a single gang or double gang mud-ring as required by number of drops specified.
- .16 Use approved cable clips or hangers at 4'-0" centres to effectively support all multi-cable harnessing.
- .17 Small numbers of cables splitting off the harness to individual room drops shall be supported by either Velcro straps or combined Panduit wirewraps/nylon ties.
- .18 Where installation is arranged in a hollow wall construction, MP1 or MP2 plates shall be used to allow maximum cable space in wall cavity.

- .19 Vertical faceplate installation is preferred for voice/data use.
- .20 Where numbers warrant, centre hung cable tray shall be installed to support major harnessing, preferably over corridor areas.
- .21 Cable tray drop-off chutes shall be fitted where cable exits this tray downward.
- .22 During installation data cable coils shall not be suspended from the structure by nylon ties or equivalent. Proper support of coils to prevent damage is essential.
- .23 One small loop of cable shall be arranged in the cable before entering the wall cavity. Excessive slack cable should be avoided as this increases run length.
- .24 Bundle data cable in transition areas between conduit and tray runs. Utilize data grade velcro ties for bundling only and not to support weight.

1.8 TESTING

- .1 Test for continuity, pair placement, pair reversal and incorrectly terminated cables. All tests in accordance with EIA/TIA TSB67 Level II.
- .2 Test and record in tabular form the following for each outlet:
 - .1 Attenuation.
 - .2 Crosstalk.
 - .3 Resistive impedance.
 - .4 Link test all individual cables in compliance with EIA/TIA TSB67.
- .3 Test and record the length of all horizontal data field wiring from the wire management panel to the workstation outlet assembly.
- .4 Supply Contract Administrator with a test summary sheet and full test results on computer disk upon completion of project. Disk format should allow client to download individual test sheets to view and print. (Microsoft Word) A copy of the summary sheet and the test data disk should be included in the Maintenance Manuals prepared by the Contractor.
- .5 An experienced data installer in compliance with Clause 1.3.1 shall perform the above testing.

1.9 WARRANTY

- .1 The Contractor shall support the above system for a period of one year from the date of acceptance by the Contract Administrator.

1.10 MAINTENANCE AGREEMENTS

- .1 The Contractor shall indicate a willingness to enter into a Maintenance Agreement at the termination of the above Warranty period.

END OF SECTION

1.1 GENERAL

- .1 All drawings and all sections of the specifications shall apply to and form an integral part of this section.

1.2 REQUIREMENTS SPECIFIED ELSEWHERE

- .1 Electrical General Provisions Section 16050
- .2 Conduits, Conduit Fastenings and Conduit Fittings Section 16111
- .3 Wires and Cables Section 16120
- .4 Outlet Boxes, Conduit Boxes and Fittings Section 16134

1.3 ELECTRIC HEATERS

- .1 Provide, install, wire and connect all convection type baseboard and fan forced wall heaters c/w thermostats sized and positioned as indicated on the drawings and schedules. All heaters shall be rated for specified voltage, constructed of minimum 18 ga. steel.
- .2 Remote thermostats shall be: low voltage (24 Volts) c/w wall plate, sub-base, covering ring and clear key-lock cover.
- .3 Provide also heavy-duty ventilated plastic guards on remote thermostats located in public areas such as entrances, washrooms, corridors and other unsupervised areas. Plastic guards to be Honeywell clear TG500A c/w lock and two keys.
- .4 All heaters with 3 phase power and all heaters in excess of 4000 watts shall be c/w built-in contactor controlled by thermostat. All units in excess of 240 volts shall be c/w built-in contactor and control transformer.
- .5 All heaters mounted on wall shall be above baseboard unless otherwise noted.
- .6 Provide built-in relays and control transformers in either the heater or on a separate matching blank heater section.
- .7 Unless specified, control transformers controlling more than one relay and in narrow type heaters shall be mounted in a separate matching enclosure adjacent to the heater.

1.4 ELECTRIC HEATERS AND CABLES

- .1 Install wire and connect all convection type, baseboard and fan forced wall heaters c/w thermostats positioned as indicated on the drawings.
- .2 Thermostats in public areas such as entrances, washrooms, corridors, and other unsupervised areas install heavy-duty ventilated plastic guards.
- .3 Make power and control connections.

- .4 Install relays, transformers and thermostats.
- .5 Interconnect heater relays to be controlled from one common thermostat.

END OF SECTION

1.1 RELATED WORK SPECIFIED ELSEWHERE

- .1 Electrical General Requirements Section 16050
- .2 Conduits, Conduit Fastenings and Conduit Fittings Section 16111
- .3 Wires and Cables Section 16120
- .4 Grouped Motor Control Section 16819
- .5 Motor Control Centre Section 16820

1.2 SHOP DRAWINGS AND PRODUCT DATA

- .1 Submit shop drawings in accordance with Section 01300 - Submittals.
- .2 Indicate:
 - .1 Mounting method and dimensions.
 - .2 Starter size and type.
 - .3 Layout of identified internal and front panel components.
 - .4 Enclosure types.
 - .5 Wiring diagram for each type of starter.
 - .6 Interconnection diagrams.

1.3 OPERATION AND MAINTENANCE DATA

- .1 Provide operation and maintenance data for motor starters for incorporation into manual specified in Section 01300 - Submittals.

1.4 MAINTENANCE MATERIALS

- .1 Provide listed spare parts for each different size and type of starter:
 - .1 4 contacts, stationary.
 - .2 4 contacts, movable.
 - .3 2 contacts, auxiliary.
 - .4 2 control transformers.
 - .5 2 operating coils.
 - .6 2 fuses.
 - .7 10 indicating lamps.
 - .8 1 HOA kit.

1.5 MATERIALS

.1 Starters: EEMAC E14-1.

.1 Half size starters not acceptable.

.2 Provide NEMA rated or IEC rated starters.

1.6 MANUAL MOTOR STARTERS

.1 Single and Three phase manual motor starters of size, type, rating, and enclosure type as indicated, with components as follows:

.1 Switching mechanism, quick make and break.

.2 Overload heaters, manual reset, trip indicating handle.

.2 Accessories:

.1 Toggle switch labelled as indicated.

.2 Indicating light: type and colour as indicated.

.3 Locking tab to permit padlocking in "ON" or "OFF" position.

.4 Flush mounted type in public areas or as indicated.

1.7 FULL VOLTAGE MAGNETIC STARTERS

.1 Magnetic of size, type, rating and enclosure type as indicated with components as follows:

.1 Contactor solenoid operated, rapid action type.

.2 Motor overload protective device in each phase, manually reset from outside enclosure.

.3 Power and control terminals.

.4 Wiring and schematic diagram inside starter enclosure in visible location.

.5 Identify each wire and terminal for external connections, within starter, with permanent number marking identical to diagram.

.6 Control transformer.

.7 Starters to be two speed where required; type to match requirement of motor provided by Division 15.

.2 Accessories:

.1 Selector switches: labelled as indicated.

- .2 Indicating lights: type and color as indicated.
- .3 2-N/O and 2-N/C spare auxiliary contacts unless otherwise indicated.
- .4 HOA selector switch.
- .5 Two speed single winding starters shall have individual Red run pilot lights for LOW and HIGH speed run indication.
- .6 An adjustable 20 sec. - 3 min. time delay relay (set at 30 sec.) shall be installed in two speed starters. It shall function only during the transition from HIGH SPEED to LOW SPEED where the motor will be in a de-energized state for a period of 30 seconds after initiation of this switching.
- .7 Provide and install time delay relay (to sequence starting after power failure) adjustable 0 - 120 seconds for motors 15 horsepower and larger.

1.8 CONTROL TRANSFORMER

- .1 Single phase, dry type, control transformer with primary voltage as indicated and 120V secondary, complete with secondary fuse, installed in starter as indicated. Size control transformer for control circuit load plus 20% spare capacity.

1.9 EQUIPMENT IDENTIFICATION

- .1 Manual starter designation label, white plate, black letters, size 1, engraved as indicated.
- .2 Magnetic starter designation label, white plate, black letters, size 4 engraved as indicated.

1.10 MANUFACTURERS

- .1 Acceptable manufacturers: Allen Bradley Canada Ltd.; Cutler Hammer Canada Ltd.; Siemens Electric Limited "System 89"; Square D.

1.11 INSTALLATION

- .1 Install starters, connect power and control as indicated.
- .2 Ensure correct fuses and overload devices elements installed.
- .3 All starters for two speed motors to be provided with six pole disconnect switches and wired with six conductors. Refer to motor schedule and drawings for two speed motors.

1.12 TESTS

- .1 Perform tests in accordance with Section 16010 - Electrical - General Requirements and manufacturer's instructions.
- .2 Operate switches, contactors to verify correct functioning.
- .3 Perform starting and stopping sequences of contactors and relays.

- .4 Check that sequence controls, interlocking with other separate related starters, equipment, control devices, operate as indicated.
- .5 Ensure motor rotation corresponds with the direction required by the driven equipment.

END OF SECTION

- 1.1 RELATED WORK SPECIFIED ELSEWHERE
 - .1 Electrical General Requirements Section 16050
 - .2 Mechanical Equipment Connection Section 16151
 - .3 Motor Starters Section 16811
- 1.2 SHOP DRAWINGS
 - .1 Submit shop drawings in accordance with Section 16010.
 - .2 Indicate:
 - .1 Outline dimensions.
 - .2 Configuration of identified compartments.
 - .3 Cable entry and exit locations.
 - .4 Schematic and wiring diagrams.
 - .5 Complete nameplate schedule.
- 1.3 OPERATION AND MAINTENANCE DATA
 - .1 Provide operation and maintenance data for incorporation into manual specified in Section 16010.
 - .2 Include data for each type and style of starter.
- 1.4 MAINTENANCE MATERIALS
 - .1 Provide maintenance manuals in accordance with Section 16010.
- 1.5 SUPPLY CHARACTERISTICS
 - .1 60 Hz., 3 phase, 3 wire, grounded, voltage as noted on drawings.
- 1.6 GENERAL DESCRIPTION
 - .1 Compartmentalized and pre-wired vertical sections.
 - .2 Wall mounting, enclosed dead front.
 - .3 Indoor CSA1 gasketed enclosure.
 - .4 Accommodating combination starters, as indicated.
- 1.7 GROUNDING
 - .1 Copper ground lugs in wiring trough.

- 1.8 MOTOR STARTERS AND DEVICES
 - .1 Starters to be as specified in Section 16811.
- 1.9 STARTER UNIT MODULES
 - .1 Units EEMAC size 4 and smaller, circuit breaker units 225A and smaller, bolt-in type.
 - .2 External operating handle of circuit switch accessible through coverplate, interlocked with door to prevent door opening with switch in "on" position. Provision for 3 padlocks to lock operating handle in "on" or "off" position and lock door closed.
 - .3 Overload relays manually reset from front with door closed.
 - .4 Pushbuttons and indicating lights mounted on door front.
 - .5 Devices and components by one manufacturer to facilitate maintenance.
- 1.10 WIRING IDENTIFICATION
 - .1 Provide wiring identification in accordance with Section 16010 - Electrical General Requirements.
- 1.11 EQUIPMENT IDENTIFICATION
 - .1 Provide equipment identification in accordance with Section 16010 - Electrical General Requirements.
 - .2 Main nameplate: Size No. 7, engraved name, number, and system.
 - .3 Individual compartment nameplates: Size No. 5, engraved with motor number, name and horsepower.
- 1.12 FINISHES
 - .1 Apply finishes in accordance with Section 16010 - Electrical General Requirements.
 - .2 Paint motor control centre light gray.
- 1.13 MANUFACTURERS
 - .1 Acceptable Manufacturers: Allen Bradley Canada Limited, Cutler Hammer Canada Limited; Siemens Electric Ltd. "System 89"; Square D.
- 1.14 INSTALLATION
 - .1 Secure grouped motor control in place, rigid, plumb and square to building wall.
 - .2 Make field power and control connections as indicated.
 - .3 Ensure correct overload heater elements installed.

1.15 TESTS

- .1 Ensure moving and working parts are lubricated where required.
- .2 Operate starters in sequence to prove satisfactory performance of motor control, motors, control devices, sequences, etc.

END OF SECTION

HEATER SCHEDULE

Project RED RIVER COMMUNITY CENTRE REDEVELOPMENT

Job Number: 03-514-01



| TYPE | WATTS | VOLTAGE | DESCRIPTION | NOTES | APPROVED MANUFACTURERS |
|------|-------|---------|---|-------|--|
| BB | 500 | 208V/1Ø | BASEBOARD CONVECTION HEATER IVORY COLOUR 700mm LONG | | CHROMALOX: BN280521 OUELLET: F0508 Q-MARK: QMK26026NW STELPRO: N5-V-8 |
| BC | 750 | 208V/1Ø | BASEBOARD CONVECTION HEATER IVORY COLOUR 980mm LONG | | CHROMALOX: BN390721 OUELLET: F0758 Q-MARK: QMK2603NW STELPRO: N7-V-8 |
| BE | 1250 | 208V/1Ø | BASEBOARD CONVECTION HEATER IVORY COLOUR 1457mm LONG | | CHROMALOX: BN571221 OUELLET: F1258 Q-MARK: QMK2605NW STELPRO: N12-V-8 |
| CF | 1750 | 208V/1Ø | SLOPE TOP TYPE CONVECTION HEATER IVORY COLOUR 2140mm LONG | | CHROMALOX: AS8F717 OUELLET: OPR1758 Q-MARK: ST07250201 STELPRO: CBB-2117-8 |
| DA | 4000 | 208V/1Ø | CONSOLE UNIT HEATER IVORY COLOUR | | CHROMALOX: CH4D04D OUELLET: OCA04038 Q-MARK: CU93504203-FF STELPRO: CBH4-WR |
| GA | 2000 | 208V/1Ø | BLOWER UNIT HEATERS C/W WALL CEILING MOUNTING BRACKETS IVORY EXTERIOR | | CHROMALOX: EUH-03B31 OUELLET: OAS02008 Q-MARK: MWUH5002 STELPRO: UH202A |
| GB | 3000 | 208V/1Ø | BLOWER UNIT HEATERS C/W WALL CEILING MOUNTING BRACKETS IVORY EXTERIOR | | CHROMALOX: EUH-03B21 OUELLET: OAS03008 Q-MARK: MWUH5003 STELPRO: UH302A |
| TA | | 240V/1Ø | BUILT-IN THERMOSTAT 2-POLE BI-METAL SWITCH RATED @ 17A | | CHROMALOX: BLTD OUELLET: F-TB2 Q-MARK: TA2ANWRC STELPRO: N2T1 |
| TC | | | CONNECT TO ADJACENT CONTROLLED HEATER | | |
| TD | | 240V/1Ø | WALL MOUNTED LINE VOLTAGE THERMOSTAT 2-POLE RATED @ 16A | | CHROMALOX: TD902 OUELLET: T-498B Q-MARK: T498B STELPRO: RJ32B2 |

LUMINAIRE SCHEDULE

Projec RED RIVER COMMUNITY CENTRE REDEVELOPMENT
Project Number: 03-514-01



| FIXT. TYPE | LAMPS | VOLTAGE | DESCRIPTION | NOTES | APPROVED MANUFACTURERS |
|------------|-----------|---------|---|-------|--|
| AB | 2 F32 T8 | 120V | SURFACE FLUORESCENT 1'x4' 2LAMP FIXTURE C/W 14GA. METAL HOUSING AND .187" PRISMATIC POLYCARBONATE REFLECTOR WHITE FINISH. PROVIDE BLOCKING AS REQUIRED. | | KENALL: SSA4-0/2-32-6 |
| AJ | 6 F32 T8 | 120V | SUSPENDED DIRECT/INDIRECT 1'x12' FIXTURE WHITE FINISH | | LIGHTOLIER: LSB-2T8-12-C-32-WH |
| DA | 2 F32 T8 | 120V | SURFACE MOUNTED 1'x4' C/W CAM ACTION HINGED FRAMED .125" K12 ACRYLIC LENS | | CFI: SLB1SFSVB240 DAY-BRITE: 1SMC-232-FS12 LITHONIA: BX232FWA12125 PEERLESS: LX-14-232-12.125-HL |
| DC | 3 F32 T8 | 120V | SURFACE MOUNTED 2'x4' C/W CAM ACTION HINGED FRAMED .125" K12 ACRYLIC LENS | | CFI: SLB2SFSVB340 DAY-BRITE: 2SMC-332-FS12 LITHONIA: 2BX332FWA12125 PEERLESS: LX-24-332-12.125-HL |
| HF | 2 F32 T8 | 120V | 2 LAMP 4 FOOT STRIP FLUORESCENT SURFACE MOUNTED. PROVIDE BLOCKING AS REQUIRED. | | C & M: STRIP-S-232 CFI: SB-248 LITHONIA: P232 PEERLESS: LS-4-232 |
| HH | 4 F32 T8 | 120V | 2 LAMP 8 FOOT STRIP TANDEM FLUORESCENT SURFACE MOUNTED. PROVIDE BLOCKING AS REQUIRED. | | C & M: TSTRIP-S232 CFI: SB-248T PEERLESS: LS-8-432 LITHONIA: TP 232 |
| KE | 2 F32 T8 | 120V | 2 LAMP STRIP FLUORESCENT C/W SOLID REFLECTORS, CHAIN SUSPENDED TO 3,000 MM AFF | | C & M: INDS-232 CFI: EE248 LITHONIA: R-232 PEERLESS: NIR-4-232 |
| LE | 2 F32 T8 | 120V | 2 LAMP STRIP FLUORESCENT MOUNTED IN VALANCE | | C & M: STRIP N232 CFI: SB248 LITHONIA: S 232 PEERLESS: LS-4-232 |
| SA | 1-70W HPS | 120V | CUTOFF WALL PACK FIXTURE DIE-CAST ALUMINIUM BACKPLATE TYPE III DISTRIBTUION BRONZE FINISH | | KENALL: MR13ED-PP-DB-70S |
| SB | 1-42W TTT | 120V | WALL MOUNTED INDIRECT FIXTURE. C/W WALL BACKPLATE SET AT 22.5°. C/W BALLAST ENCLOSURE IN BASE WHITE FINISH | | ELLIPTIPAR: M115-100GE-A KEENE: FPS-042/HF-W |
| SC | 1-70W HPS | 120V | CUTOFF WALL PACK FIXTURE DIE-CAST ALUMINIUM BACKPLATE TYPE III DISTRIBTUION BRONZE FINISH WALL MOUNTED UPLIGHT | | KEENE: RDW 070 LX |
| SE | 1-70W HPS | 120V | RECESSED HID POTLIGHT C/W POLYCARBONATE LENS AND CAST GUARD | | CFI: VA8BGL/VA8B70SA |

LUMINAIRE SCHEDULE

Projec RED RIVER COMMUNITY CENTRE REDEVELOPMENT
 Project Number: 03-514-01



| FIXT. TYPE | LAMPS | VOLTAGE | DESCRIPTION | NOTES | APPROVED MANUFACTURERS |
|------------|---------------|---------|--|-------|---|
| SG | 1-250W HPS | 120V | POLE MOUNTED, SINGLE HEAD SITE LIGHTING LUMINAIRE MOUNTED ON 125MM SQUARE X 6100 MM LONG STEEL POLE BRONZE FINISH | | LITHONIA: KC1-250S-R3 KEENE: SR2B-25-3-LX |
| SJ | 2-250W HPS | 120V | POLE MOUNTED, DOUBLE HEAD SITE LIGHTING LUMINAIRE MOUNTED ON 125MM SQUARE X 6100 MM LONG STEEL POLE BRONZE FINISH | | LITHONIA: KC1-250S-R3 KEENE: SR2B-25-3-LX |
| WA | 1-26W DTT | 120V | RECESSED 1 LAMP FLUORESCENT POT LIGHT C/W BLACK MULTIGROOVE DIE-CAST BAFFLE WHITE TRIM RING - 6½" Ø OPENING | | LITHONIA: LP6F-6B3 CAPRI: CM6-F126-S1/H65B LIGHTOLIER: 1102P26VG/1105 |
| E-8 | LED | 120V | POLYCARBONATE SEALED ENCLOSURE EXIT LIGHT C/W LED LAMP WHITE BODY | | EMERGI-LITE: SVX SERIES |

MOTOR SCHEDULE



| MOTOR No. | NAME | LOCATION | H.P. (kW) | VOLTS | STARTER & ACC. | | | | CIRCUIT | STARTER LOCATION | FEEDER | REMARKS |
|-----------|--------------------|----------------|-----------|---------|----------------|-----|----|-----|------------|------------------|--------|--|
| | | | | | MAN | MAG | PL | HOA | | | | |
| F-1 | CEILING PROP FAN | ROOM 102 | 70W | 120V 1ø | | | | | A-38 | N/A | 2#12 | CONTROLLER BY DIV.15 INSTALLED AND CONNECTED BY DIV.16 |
| EF-1 | EXHAUST FAN | MECH ROOM 201 | 3 | 208V 3ø | | ✓ | ✓ | ✓ | MCC-A | | 3#10 | |
| EF-2 | RANGE HOOD | KITCHEN 106 | 1/10 | 120V 1ø | | | | | B-23 | N/A | 2#12 | PROVIDE 60W A-19 LAMPS AS REQUIRED S |
| EF-3 | EXHAUST FAN | ROOM 117A | 1 | 208V 3ø | | ✓ | ✓ | ✓ | A-40,41,42 | ROOM 117A | 3#12 | INTERLOCK WITH AHU-1 |
| AHU-1 | AIR HANDLING UNIT | MECH ROOM 117B | 5 | 208V 3ø | | | | | A-43,44,45 | PACKAGED UNIT | 3#10 | WIRE AND CONNECT REMOTE CONTROL PANEL, INTERLOCK WITH CU-4 |
| AHU-2 | AIR HANDLING UNIT | MECH ROOM 201 | 5 | 208V 3ø | | | | | MCC-A | PACKAGED UNIT | 3#10 | PROVIDE BREAKER ONLY IN MCC. WIRE AND CONNECT REMOTE CONTROL PANEL |
| AHU-3 | AIR HANDLING UNIT | ROOM 201 | 2 | 208V 3ø | | | | | MCC-A | PACKAGED UNIT | 3#12 | PROVIDE BREAKER ONLY IN MCC. WIRE AND CONNECT REMOTE CONTROL PANEL |
| AHU-4 | AIR HANDLING UNIT | MECH ROOM 201 | 1/8 | 120V 1ø | ✓ | | ✓ | | B-40 | PACKAGED UNIT | 2#12 | INTERLOCK WITH RH-1 AND CONNECT REMOTE STAT |
| CU-1 | CONDENSING UNIT | AT GRADE | 21.3 FLA | 208V 3ø | | | | | MD-2A | PACKAGED UNIT | 3#8 | INTERLOCK WITH AHU-3 |
| CU-2 | CONDENSING UNIT | AT GRADE | 54 FLA | 208V 3ø | | | | | MD-2A | PACKAGED UNIT | 3#4 | INTERLOCK WITH AHU-2 |
| CU-3 | CONDENSING UNIT | AT GRADE | 11 FLA | 208V 3ø | | | | | MCC-A | PACKAGED UNIT | 3#10 | PROVIDE BREAKER ONLY IN MCC. INTERLOCK WITH AHU-4 |
| CU-4 | CONDENSING UNIT | AT GRADE | 11 FLA | 208V 3ø | | | | | A-46,47,48 | N/A | 3#10 | INTERLOCK WITH AHU-1 |
| RH-1 | ELECTRIC DUCT COIL | MECH ROOM 201 | (4.5) | 208V 3ø | | | | | B-44,45 | N/A | 3#10 | INTERLOCK WITH AHU-4 AND CONNECT REMOTE STAT |

MOTOR SCHEDULE



| MOTOR No. | NAME | LOCATION | H.P. (kW) | VOLTS | STARTER & ACC. | | | | CIRCUIT | STARTER LOCATION | FEEDER | REMARKS |
|-----------|-----------------------|---------------|-----------|---------|----------------|-----|----|-----|---------|------------------|--------|---------------------------------|
| | | | | | MAN | MAG | PL | HOA | | | | |
| P-1 | SUMP PUMP | ROOM 109 | 1/3 | 120V 1Ø | ✓ | | ✓ | | B-51 | BY PUMP | 2#12 | CONNECT REMOTE ALARM CONTROLLER |
| P-2 | HOT WATER RECIRC PUMP | ROOM 117A | 1/2 | 120V 1Ø | ✓ | | ✓ | | A-39 | BY PUMP | 2#12 | RUNS CONTINUOUSLY. |
| P-3 | GLYCOL RECIRC PUMP | MECH ROOM 201 | 1.5 | 208V 3Ø | | ✓ | ✓ | ✓ | MCC-A | | 3#12 | INTERLOCK WITH AHU-2 |
| P-4 | GLYCOL FILL PUMP | MECH ROOM 201 | 1/6 | 120V 1Ø | ✓ | | ✓ | | B-41 | BY PUMP | 2#12 | |
| P-5 | GLYCOL FILL PUMP | ROOM 117B | 1/6 | 120V 1Ø | ✓ | | ✓ | | A-49 | BY PUMP | 2#12 | |
| P-6 | GLYCOL RECIRC PUMP | ROOM 117B | 1/2 | 120V 1Ø | ✓ | | ✓ | | A-50 | BY PUMP | 2#12 | INTERLOCK WITH AHU-1 |
| P-7 | SUMP PUMP | ROOM 126 | 1/3 | 120V 1Ø | ✓ | | ✓ | | A-53 | BY PUMP | 2#12 | CONNECT REMOTE ALARM CONTROLLER |

| PANEL: A | | LOCATION: ROOM 125 | | | | | | LOCATION: ROOM 109 | |
|---------------------------------------|-----------|--------------------|----------|-------------------|----------|-----------|-----------|---|--|
| FED FROM: MD-2A | | | | | | | | | |
| Designation | Load (VA) | Ckt. Trip | bkr. No. | Phase | Ckt. No. | bkr. Trip | Load (VA) | Designation | |
| ELECTRIC HEAT ROOM 118 2 # 10 | 2500 | 30 2P | 1 | A | 31 | 15 | 800 | ELECTRIC DOOR OPERATORS | |
| | 2500 | | 2 | B | 32 | 15 | 600 | 2R ROOM 111,112 RECEPTACLES | |
| ELECTRIC HEAT ROOM 118 2 # 10 | 2500 | 30 2P | 3 | C | 33 | 15 | 1000 | 1R VENDING MACHINE REC | |
| | 2500 | | 4 | A | 34 | 15 | 1000 | 1R VENDING MACHINE REC | |
| ELECTRIC HEAT ROOM 118 2 # 10 | 2000 | 30 2P | 5 | B | 35 | 15 | 200 | AHU-1 CONTROL PANEL | |
| | 2000 | | 6 | C | 36 | 15 | 800 | 2R EXTERIOR RECEPTACLES | |
| ELECTRIC HEAT ROOM 118 2 # 10 | 1875 | 30 2P | 7 | A | 37 | 15 | 900 | 6R ROOM 113,14,15,16,19,20 RECEPTACLES | |
| | 1875 | | 8 | B | 38 | 15 | 150 | FAN F-1 | |
| ELECTRIC HEAT ROOM 118 2 # 12 | 1375 | 20 2P | 9 | C | 39 | 20 | 1075 | PUMP P-2 | |
| | 1375 | | 10 | A | 40 | 15 | 475 | FAN EF-3 | |
| ELECTRIC HEAT ROOM 102 2 # 10 | 2250 | 30 2P | 11 | B | 41 | 3P | 475 | | |
| | 2250 | | 12 | C | 42 | | 475 | | |
| ELECTRIC HEAT ROOM 101 2 # 10 | 2000 | 30 2P | 13 | A | 43 | 40 | 2005 | AIR HANDLING UNIT AHU-1 | |
| | 2000 | | 14 | B | 44 | 3P | 2005 | | |
| ELECTRIC HEAT ROOM 125, 126 2 # 10 | 2000 | 30 2P | 15 | C | 45 | | 2005 | | |
| | 2000 | | 16 | A | 46 | | 1320 | CONDENSING UNIT CU-4 | |
| HAND DRYERS | 1100 | 15 2P | 17 | B | 47 | 30 3P | 1320 | | |
| | 1100 | | 18 | C | 48 | | 1320 | | |
| HAND DRYERS | 1100 | 15 2P | 19 | A | 49 | 15 | 375 | PUMP P-5 | |
| | 1100 | | 20 | B | 50 | 20 | 1075 | PUMP P-6 | |
| FIRE ALARM PANEL LD | 200 | 15 | 21 | C | 51 | 20 2P | 2000 | HOT WATER HEATER | |
| HAND DRYERS | 1100 | 15 2P | 22 | A | 52 | 15 | 2000 | | |
| | 1100 | | 23 | B | 53 | 15 | 800 | PUMP P-7 | |
| HAND DRYERS | 1100 | 15 2P | 24 | C | 54 | 15 | | SPARE | |
| | 1100 | | 25 | A | 55 | 15 | | SPARE | |
| ROOM 125,126 RECEPTAC | 4R 600 | 15 | 26 | B | 56 | 15 | | SPARE | |
| ROOM 125 RECEPTACLE | 1R 200 | 15 | 27 | C | 57 | 15 | | SPARE | |
| ROOM 118,22,23,24 RECEPTACLES | 6R 600 | 15 | 28 | A | 58 | | | | |
| ROOM 102 RECEPTACLE | 4R 600 | 15 | 29 | B | 59 | | | | |
| ELECTRIC DOOR OPERATOR | 1000 | 15 | 30 | C | 60 | | | | |
| VOLTAGE: 120/208V,3Ø,4W | | CAPACITY: 225 A. | | MOUNTING: SURFACE | | REMARKS: | | LOADS - PH.A 25025 PH.B 21750 PH.C 22400 TOTAL 69175 | |

SMS ENGINEERING
SMS Engineering Ltd. Consulting
 Engineers
 770 Bradford Street Winnipeg MB Canada R3H

**PANEL SCHEDULE
 A**

PROJECT: RED RIVER COMM. CENTRE
 FILE: 03-514-01
 DATE: 13-Apr-05

PANEL: **B**
FED FROM: MD-2A

LOCATION: ROOM 201
LOCATION: ROOM 109

| Designation | Load (VA) | Ckt. Trip | bkr. No. | Phase | Ckt. No. | bkr. Trip | Load (VA) | Designation |
|-----------------------------------|-----------|------------------|----------|---------|----------|-------------|-----------|--|
| LIGHTING ROOM 110 | 885 | 15 | | | | 15 | 800 | 4R RECEPTACLE ROOM 201 |
| LIGHTING ROOM 110 | 950 | 15 | 1 | A | 31 | 15 | 800 | 1R RECEPTACLE FREEZER ROOM 105 |
| LIGHTING ROOM 110 | 950 | 15 | 2 | B | 32 | 15 | 1000 | 2-1/2R RECEPTACLE ROOM 106 |
| LIGHTING ROOM 105,06,07,08,09,201 | 1225 | 15 | 3 | C | 33 | 15 | 1000 | 2-1/2R |
| LIGHTING ROOM 104 | 1020 | 15 | 4 | A | 34 | 2P | 500 | 1/2R RECEPTACLE ROOM 106 |
| PYLON SIGN | 1000 | 15 | 5 | B | 35 | 2P | 500 | 1/2R |
| SITE LIGHTING | 570 | 15 | 6 | C | 36 | 15 | 1000 | 1R RECEPTACLE ICE MAKER ROOM 107 |
| SITE LIGHTING | 1140 | 15 | 7 | A | 37 | 30 | 1750 | ELECTRIC HEAT ROOM 104 |
| EXTERIOR LIGHTING | 990 | 15 | 8 | B | 38 | 2P | 1750 | 2 # 10 |
| RECEPTACLE ROOM 110 | 400 | 15 | 9 | C | 39 | 15 | 400 | AHU-4 |
| RECEPTACLE ROOM 110 | 400 | 15 | 10 | A | 40 | 15 | 530 | PUMP P-4 |
| RECEPTACLE ROOM 110 | 400 | 15 | 11 | B | 41 | 15 | 400 | AHU CONTROL PANELS |
| RECEPTACLE ROOM 110 | 400 | 15 | 12 | C | 42 | 15 | | SPARE |
| RECEPTACLE ROOM 110 | 400 | 15 | 13 | A | 43 | 30 | 2250 | REHEAT COIL RH-1 |
| RECEPTACLE ROOM 107,(| 400 | 15 | 14 | B | 44 | 2P | 2250 | 2 # 10 |
| RECEPTACLE ROOM 105,(| 1000 | 15 | 15 | C | 45 | 20 | 1500 | ELECTRIC HEAT ROOM 109 |
| 3 # 12 | 1000 | 15 | 16 | A | 46 | 2P | 1500 | |
| 2-1/2R | 1000 | 15 | 17 | B | 47 | 2P | 1500 | |
| RECEPTACLE ROOM 105,(| 1000 | 15 | 18 | C | 48 | 20 | 1500 | ELECTRIC HEAT ROOM 201 |
| 3 # 12 | 1000 | 15 | 19 | A | 49 | 2P | 1500 | |
| 2-1/2R | 1000 | 15 | 20 | B | 50 | 15 | 800 | 1R RECEPTACLE ROOM 107 |
| RECEPTACLE ROOM 105,(| 1000 | 15 | 21 | C | 51 | 15 | 800 | SUMP PUMP P-1 |
| 3 # 12 | 800 | 15 | 22 | A | 52 | 15 | 815 | LIGHTS ROOM 110 |
| RECEPTACLE FRIDGE RO | 400 | 15 | 23 | B | 53 | 15 | 915 | EXIT LIGHTS, NIGHT LIGHTS AND BATTERY BANK |
| RECEPTACLE ROOM 105,(| 800 | 15 | 24 | C | 54 | 15 | 1150 | LIGHTS ROOM 111,12 |
| RECEPTACLE FRIDGE RO | 800 | 15 | 25 | A | 55 | 15 | 750 | LIGHTS ROOM 102,18,23 |
| RECEPTACLE FRIDGE RO | 800 | 15 | 26 | B | 56 | 15 | 1225 | LIGHTS ROOM 113,14,15,16 |
| RANGE RECEPTACLE RO | 3000 | 50 | 27 | C | 57 | 15 | 815 | LIGHTS ROOM 121,22,24,25,26 |
| 3 # 8 | 3000 | 2P | 28 | A | 58 | 15 | | SPARE |
| RECEPTACLE ROOM 104 | 800 | 15 | 29 | B | 59 | 15 | | SPARE |
| RECEPTACLE ROOM 104 | 600 | 15 | 30 | C | 60 | 15 | | SPARE |
| VOLTAGE: 120/208V,3Ø,4W | | CAPACITY: 225 A. | | LOADS - | | PH.A 17845 | | |
| MOUNTING: SURFACE | | | | | | PH.B 18180 | | |
| REMARKS: | | | | | | PH.C 20305 | | |
| | | | | | | TOTAL 56330 | | |

SMS ENGINEERING
SMS Engineering Ltd. Consulting Engineers
 770 Bradford Street Winnipeg MB Canada R3H

PANEL SCHEDULE B

PROJECT: RED RIVER COMM. CENTRE
 FILE: 03-514-01
 DATE: 13-Apr-05

