

FILE NAME: 20040230.dwg(10/1) DATE: 2007.10.05 DESCRIPTION: BULKHEAD & COLUMN SECTIONS, STAIR PLANS, ELEVATIONS & DETAILS PROJECT No.: 2004-023 ADDRESS: 1400 HENDERSON HIGHWAY

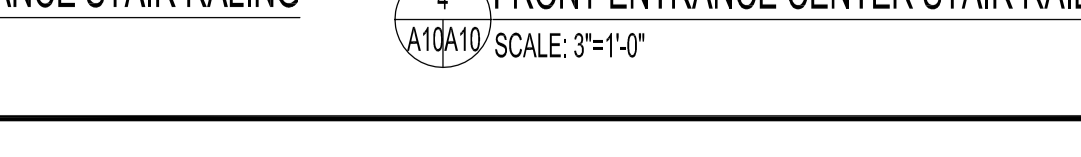
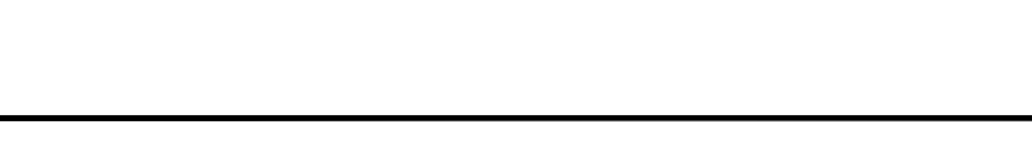
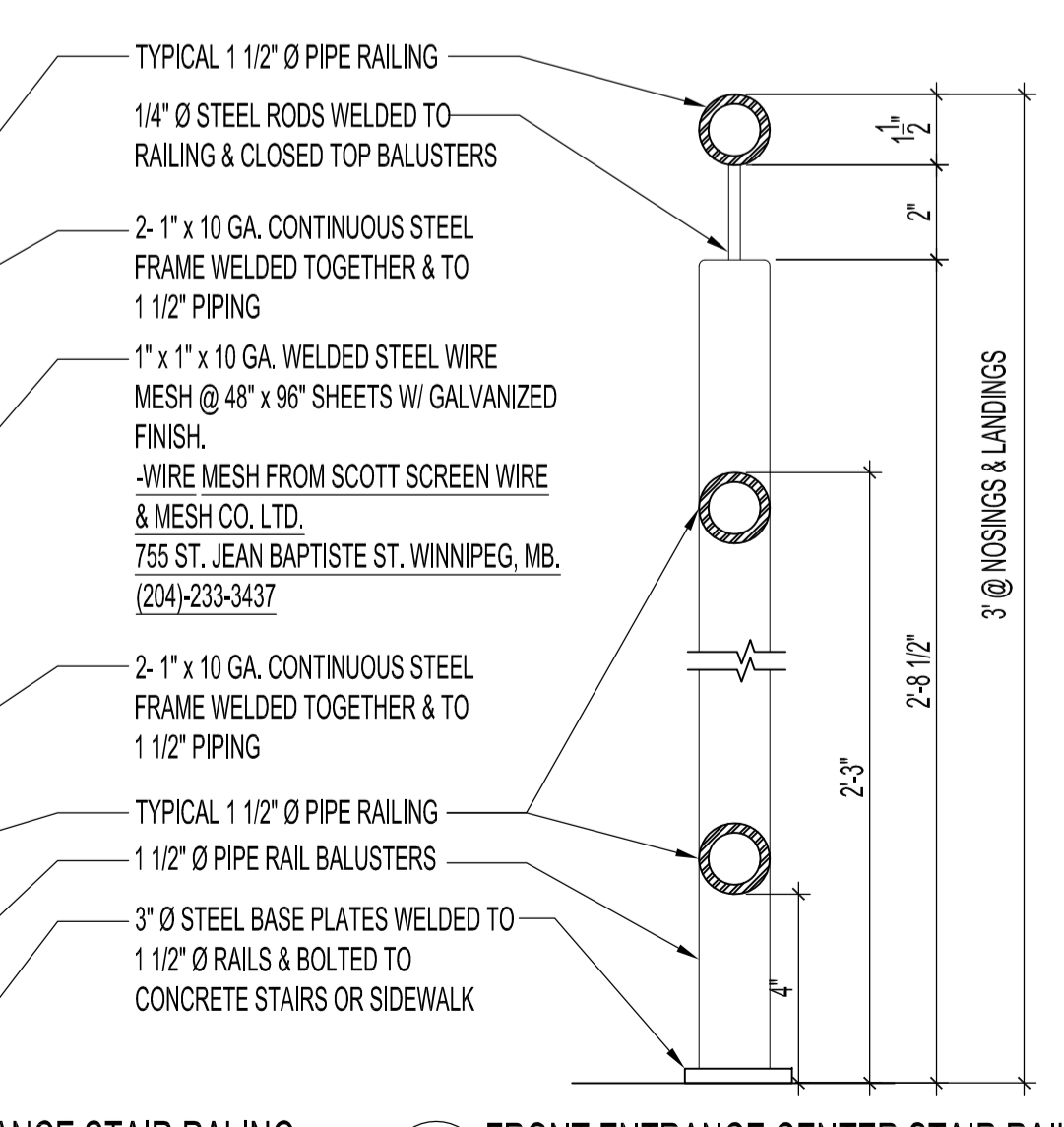
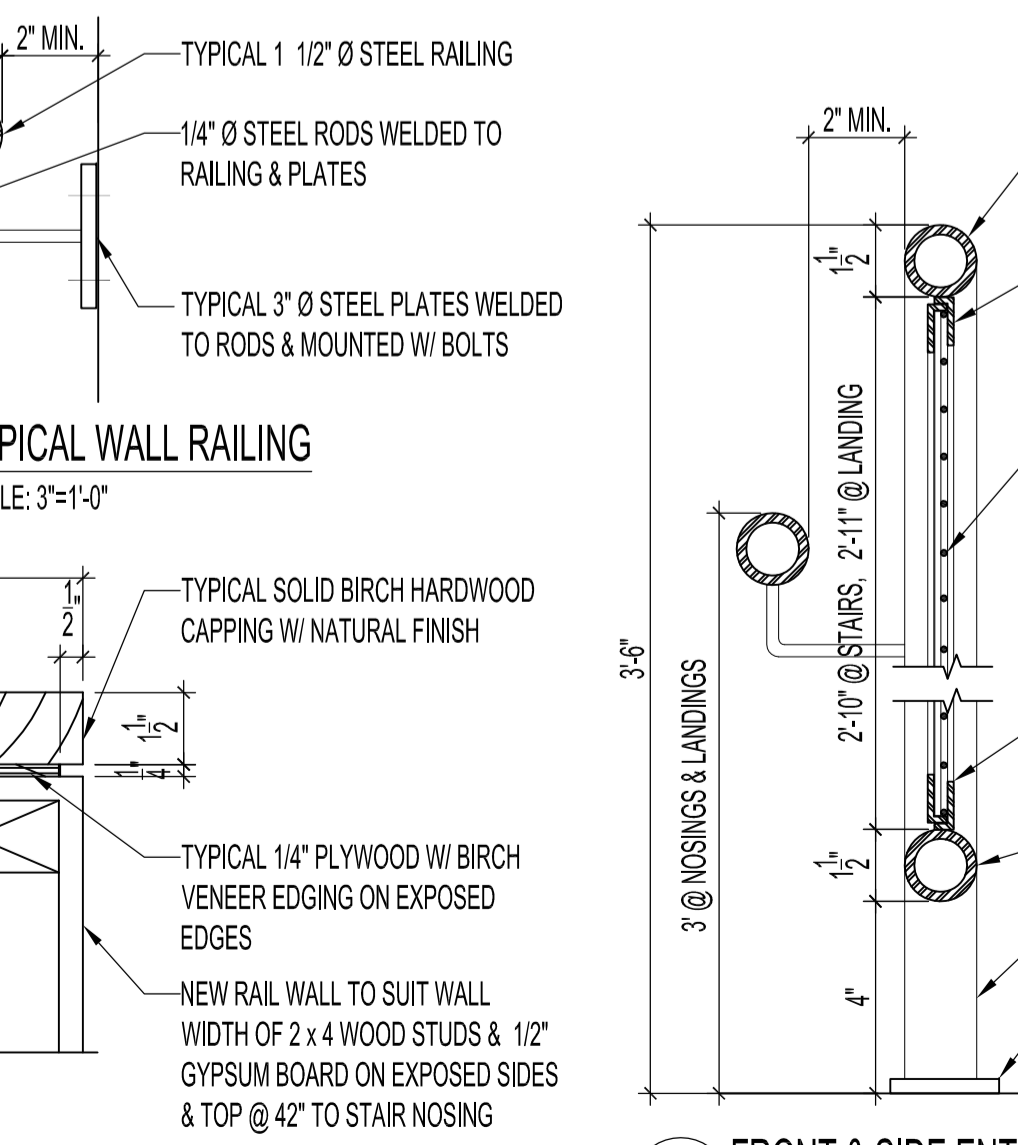
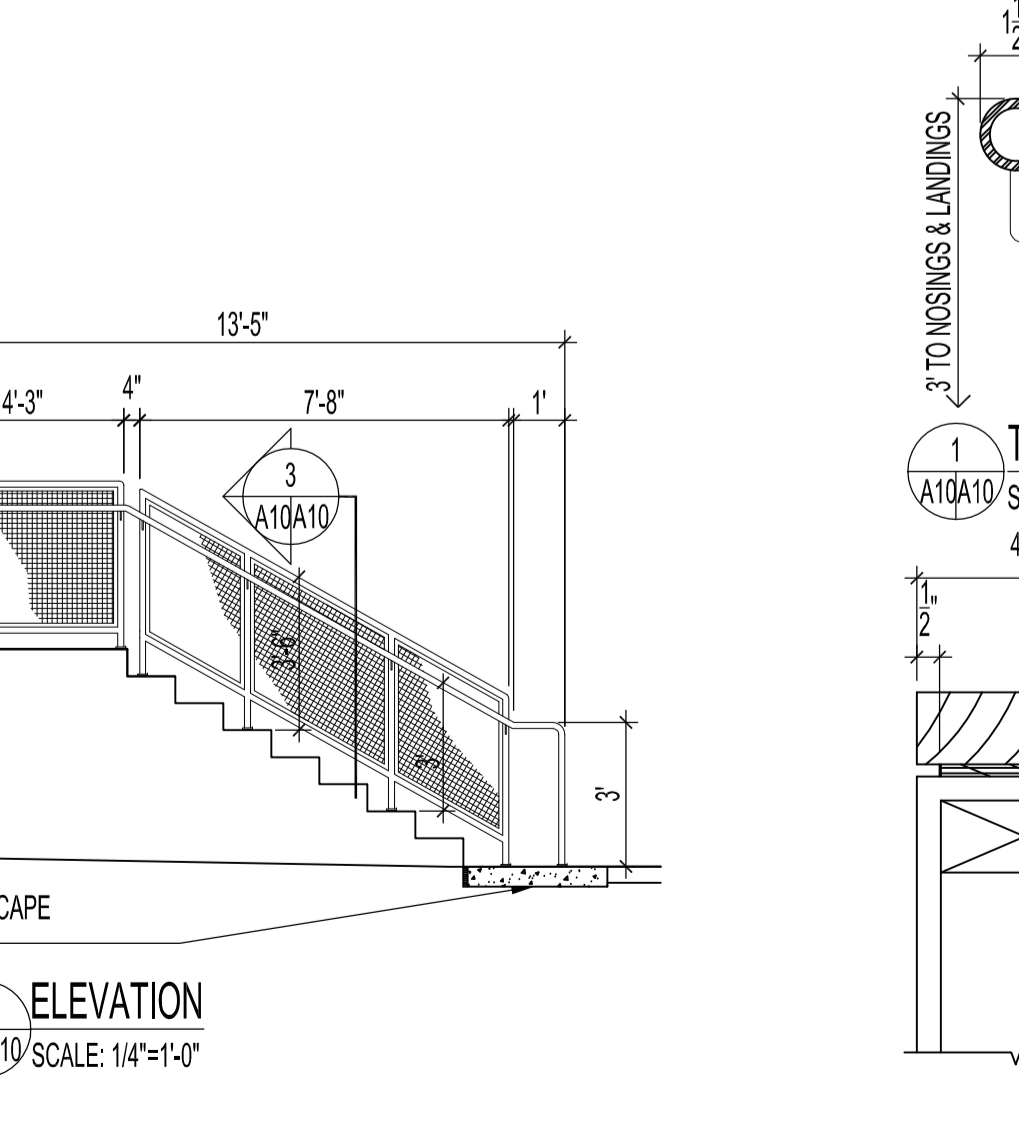
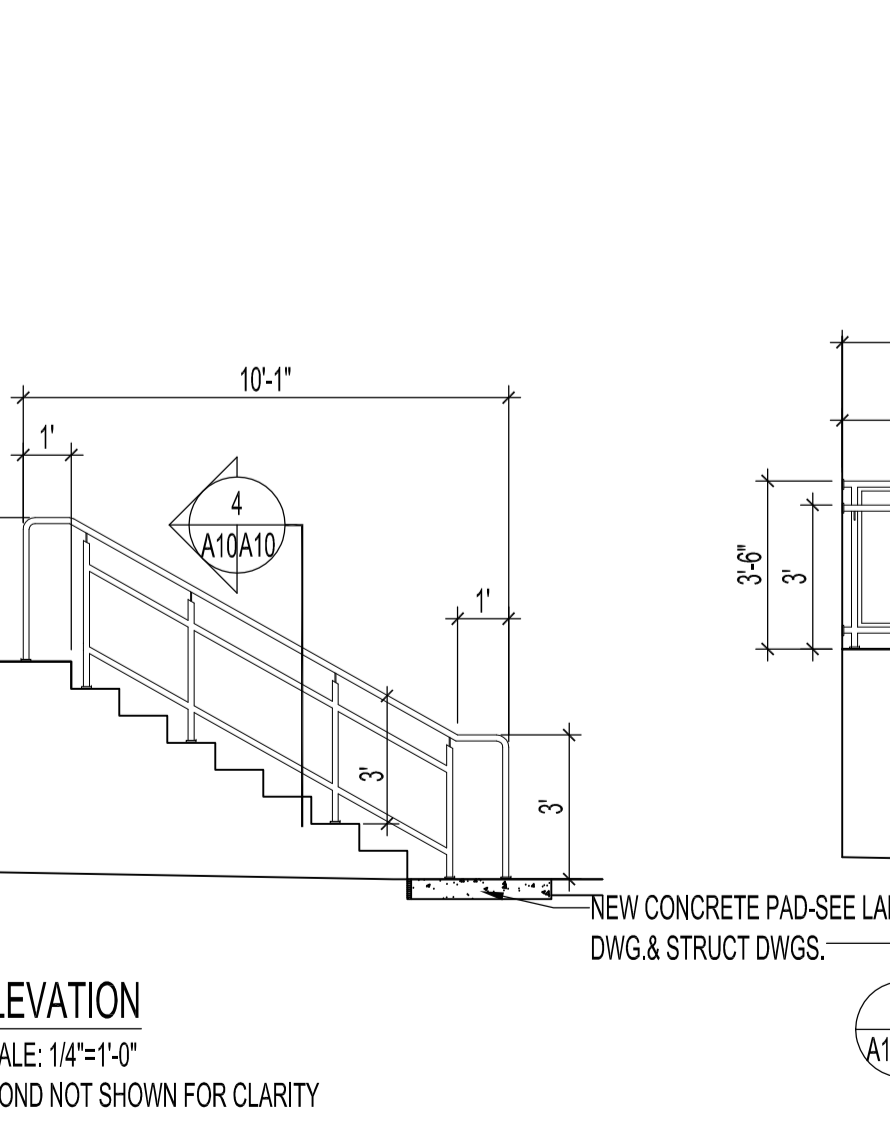
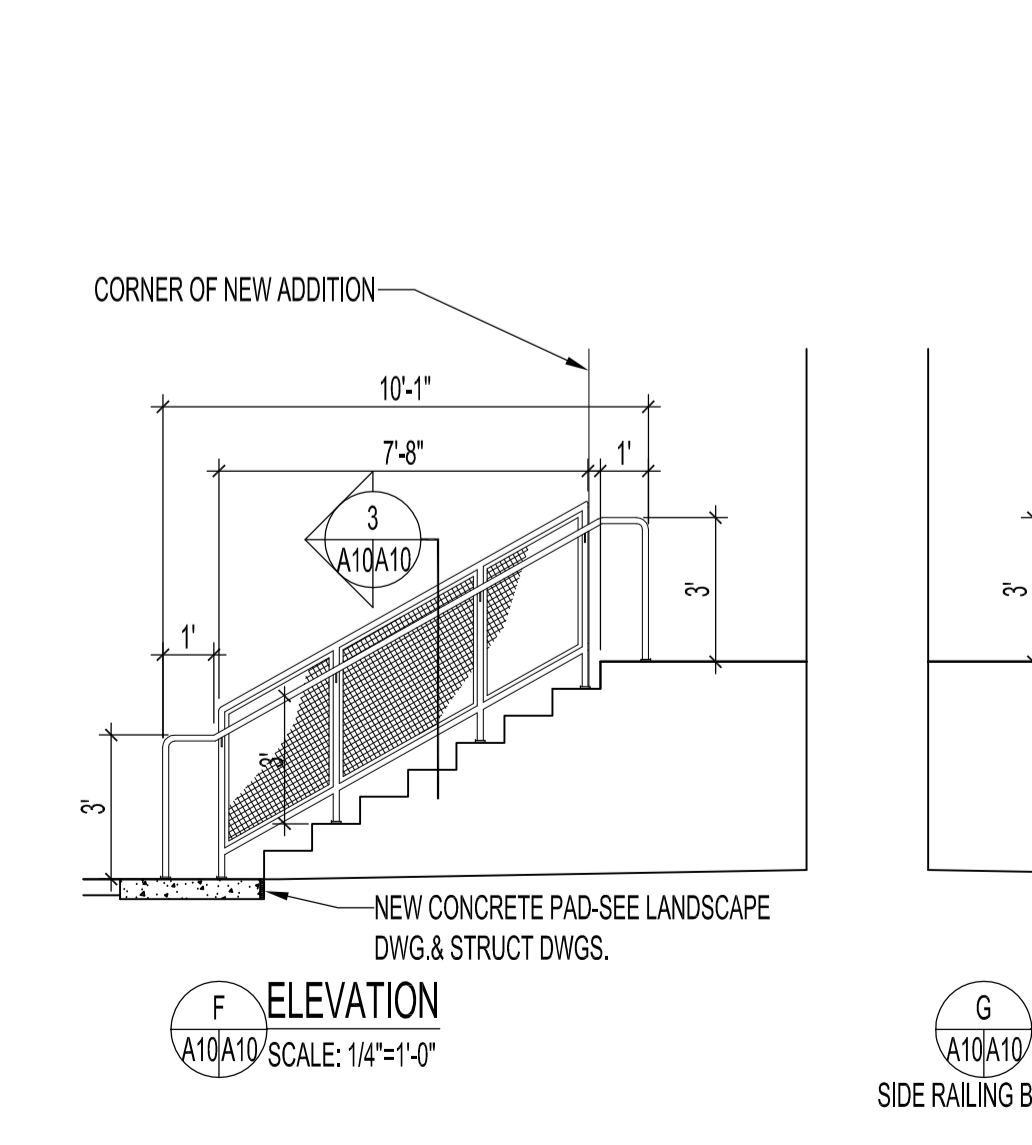
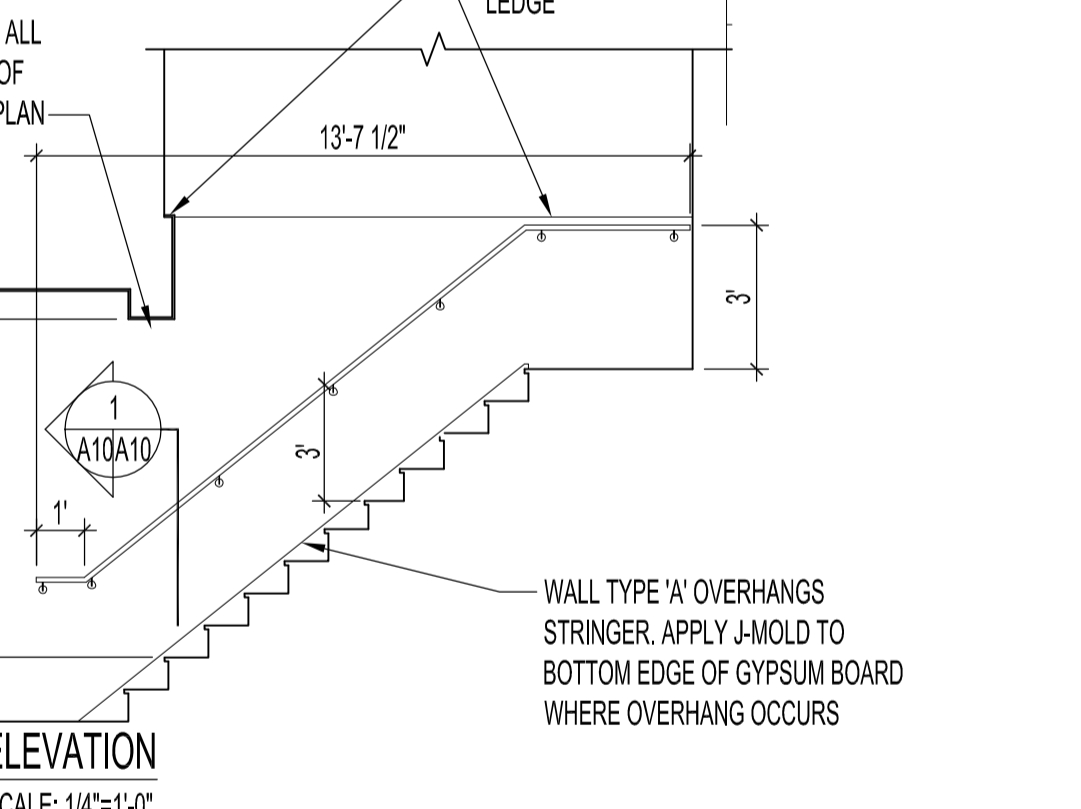
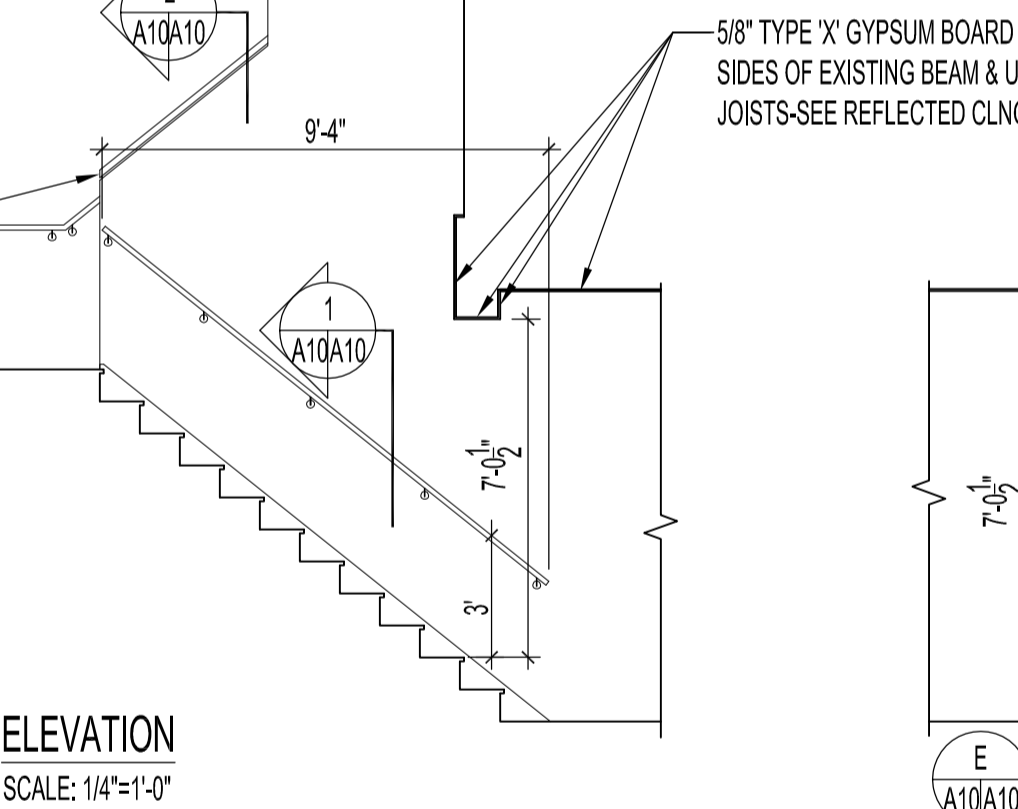
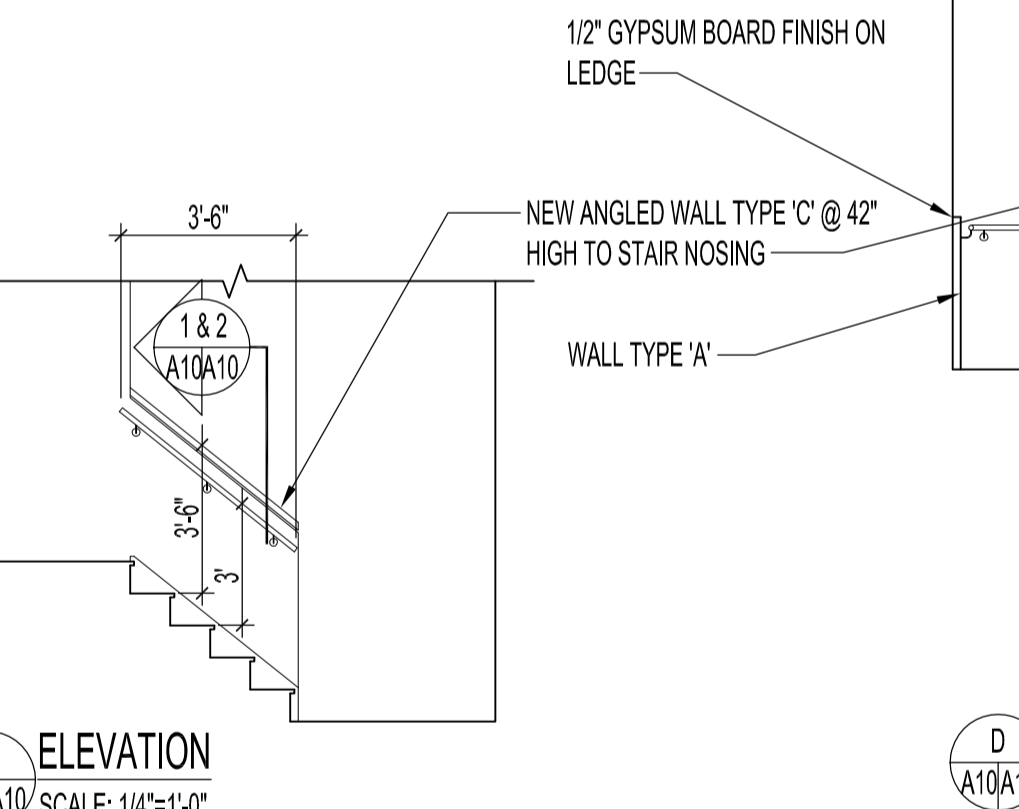
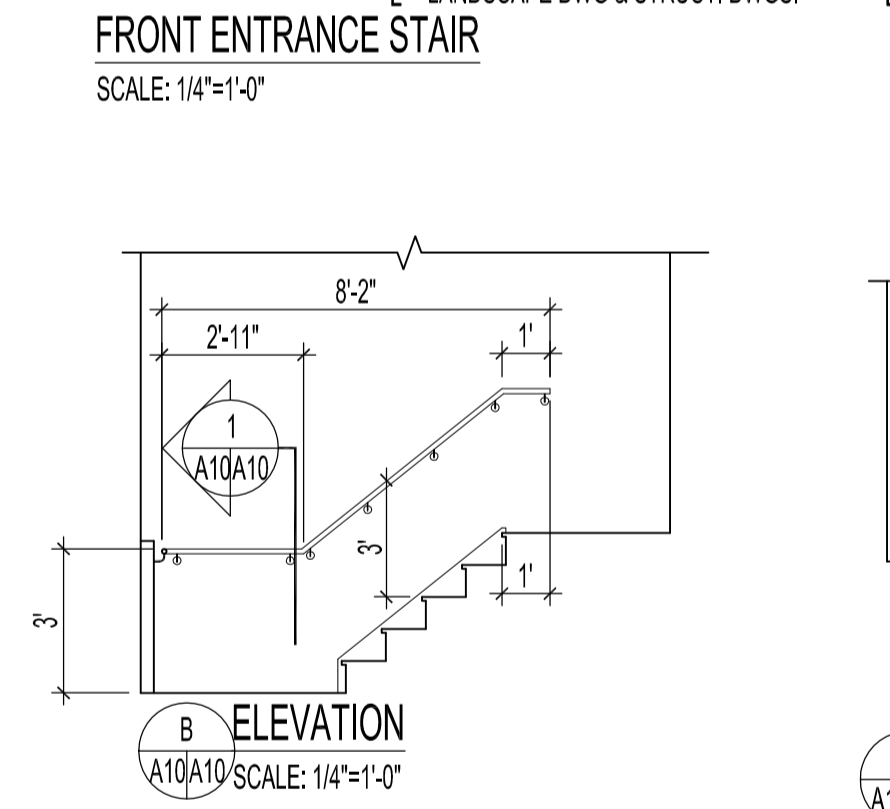
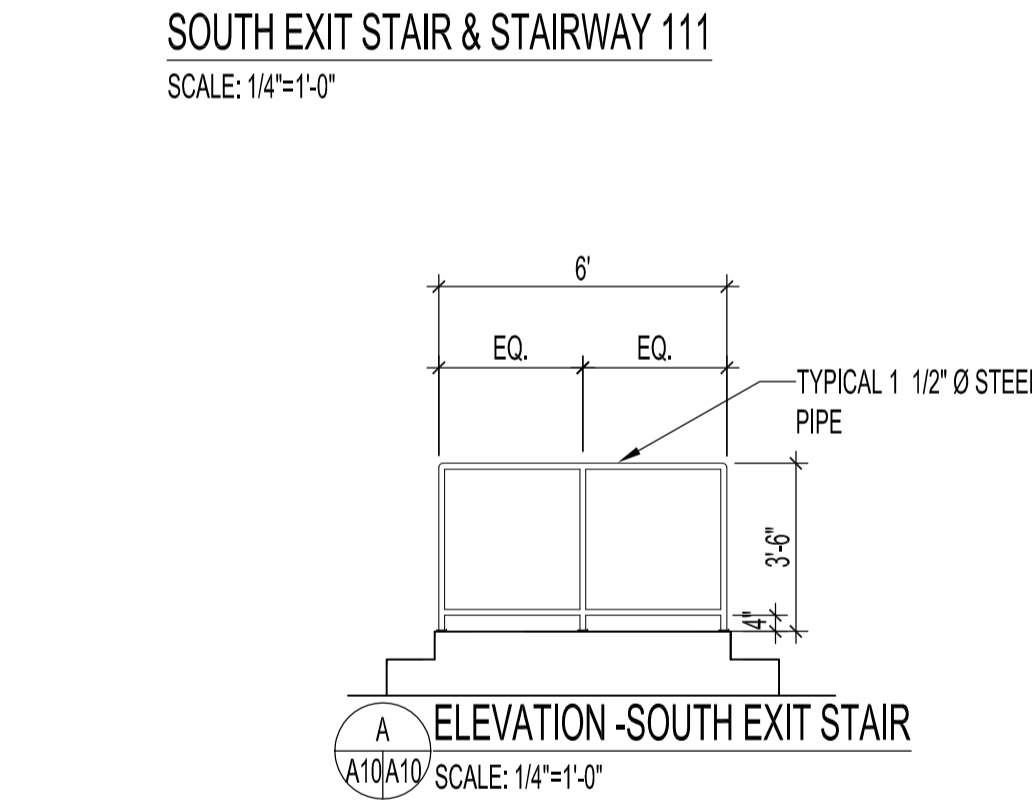
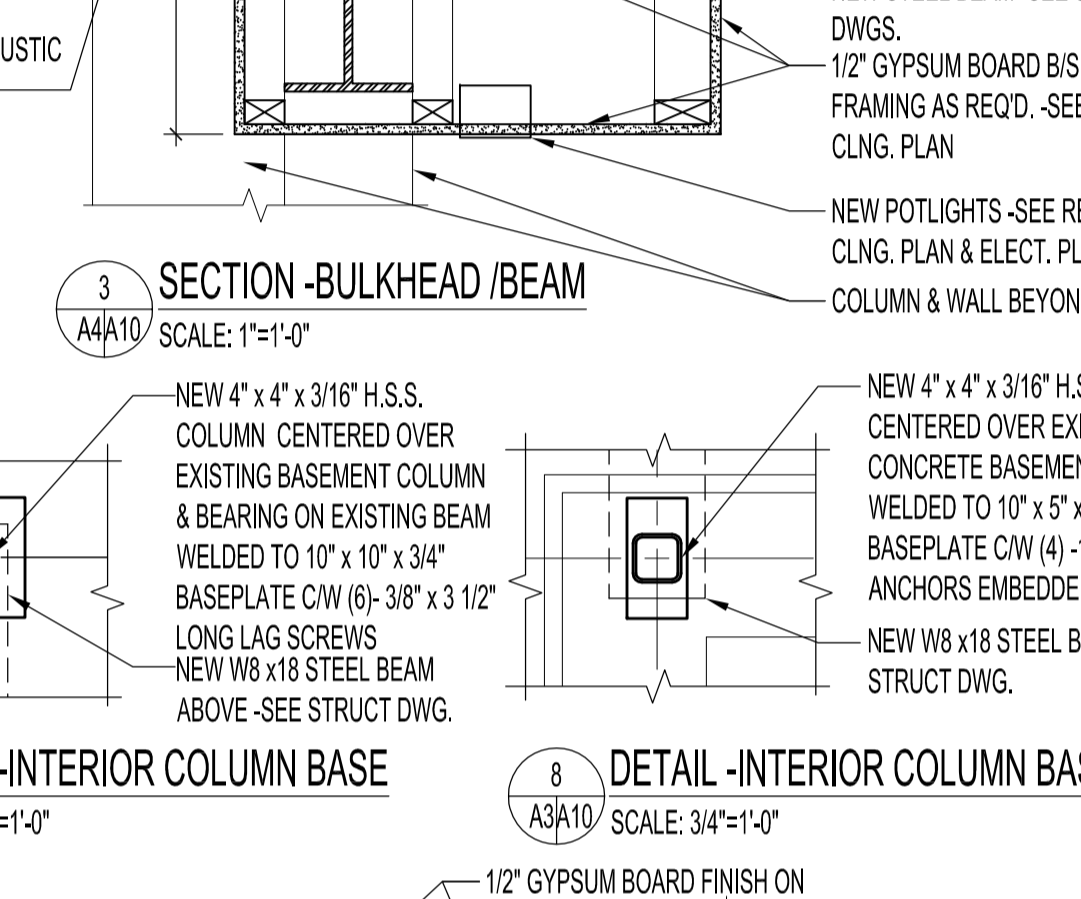
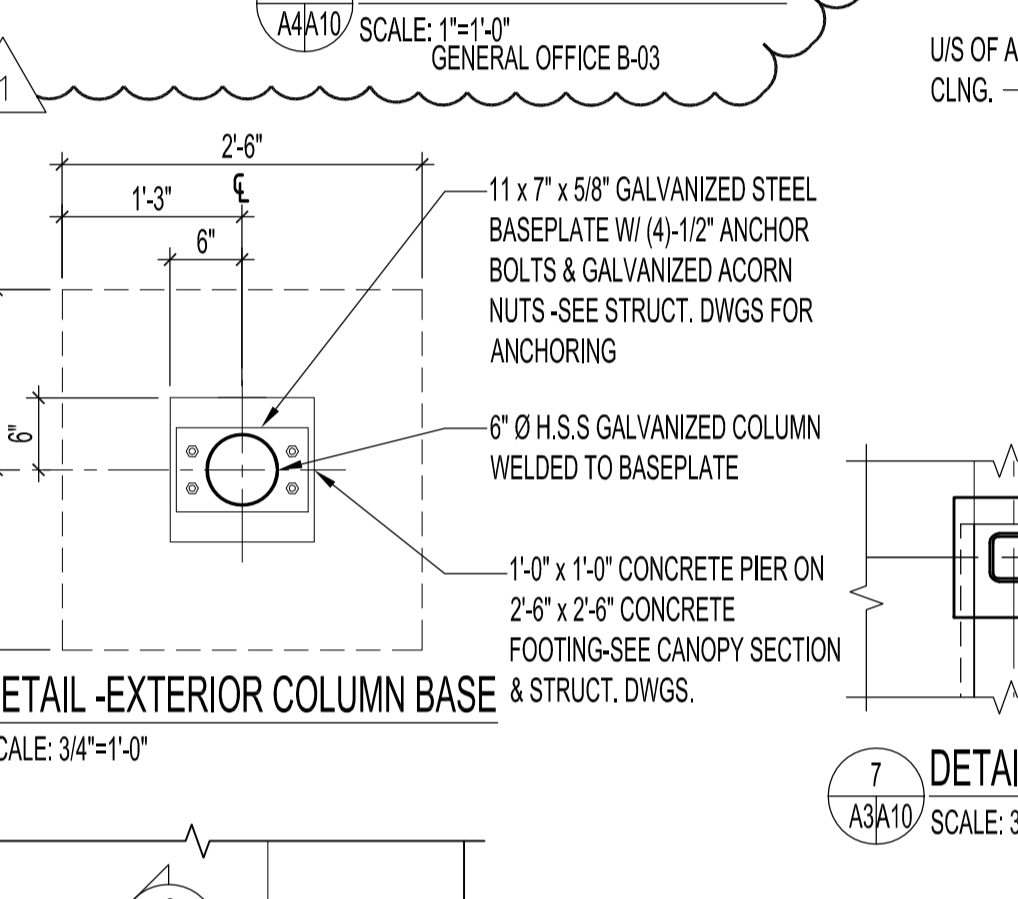
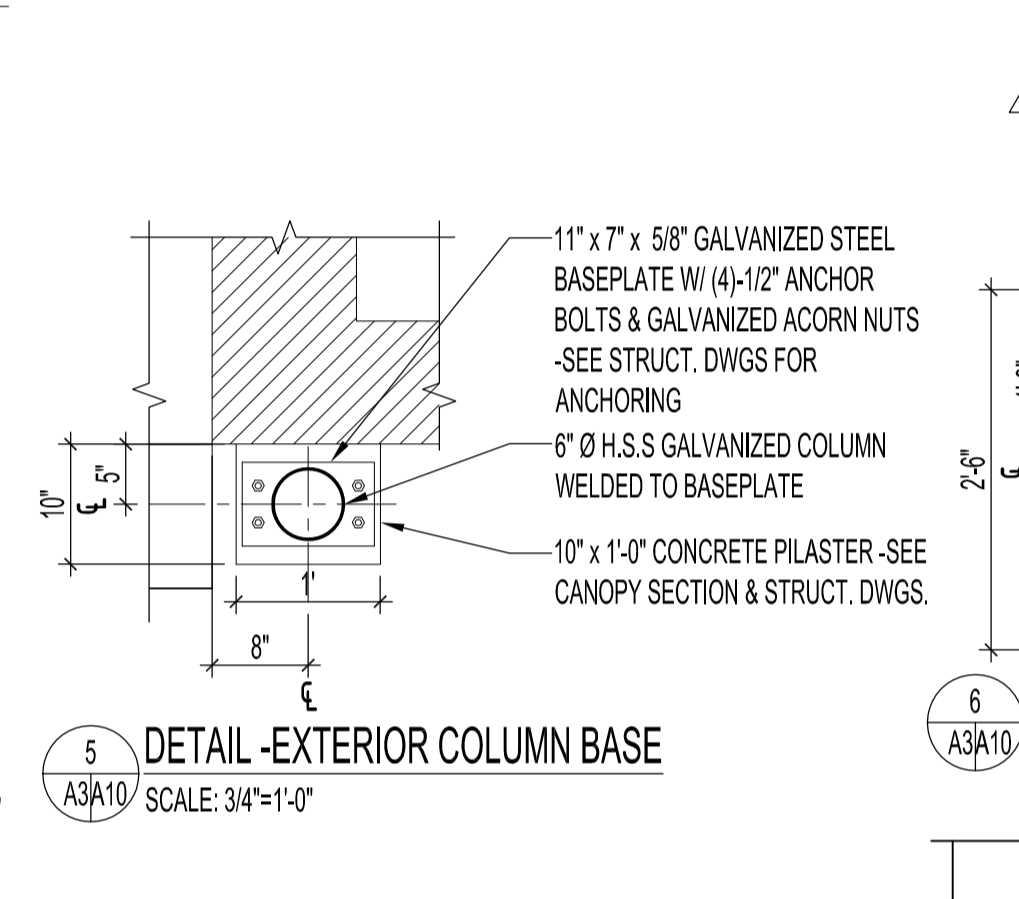
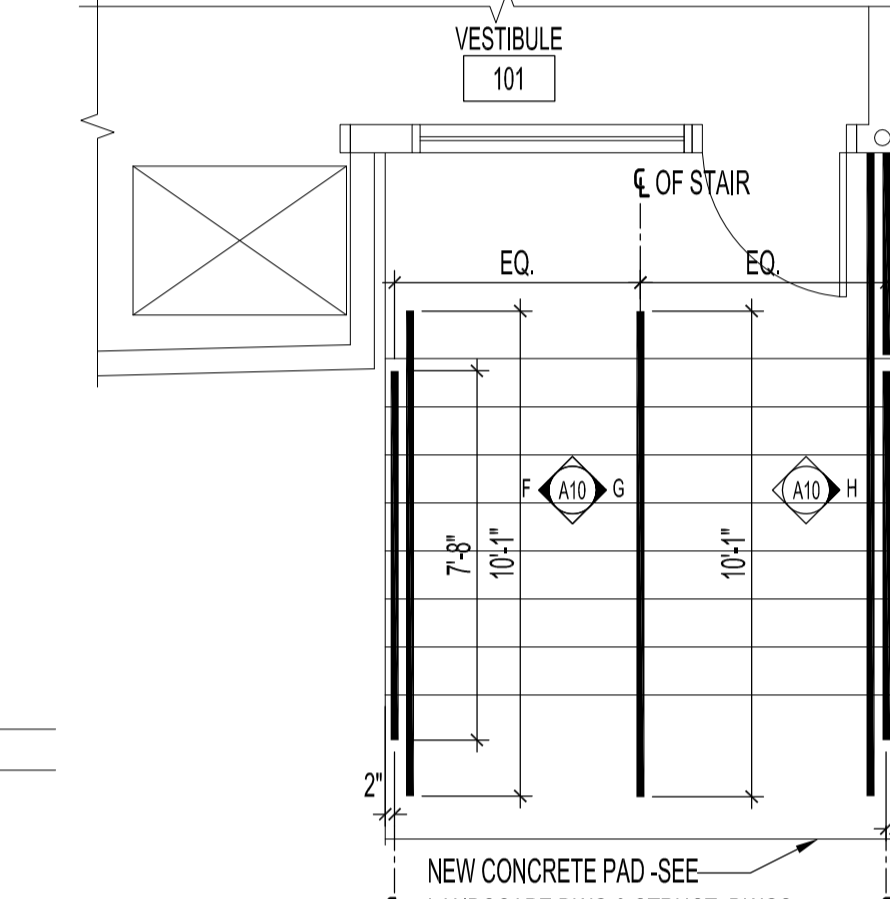
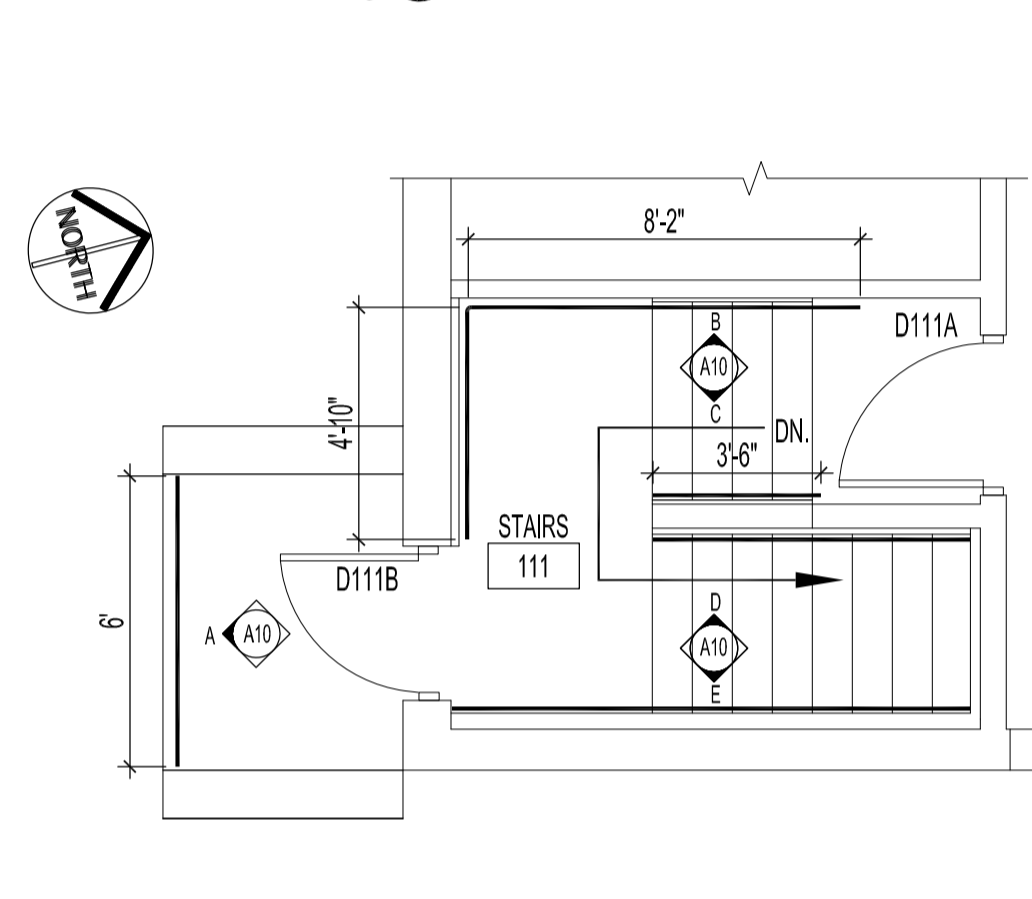
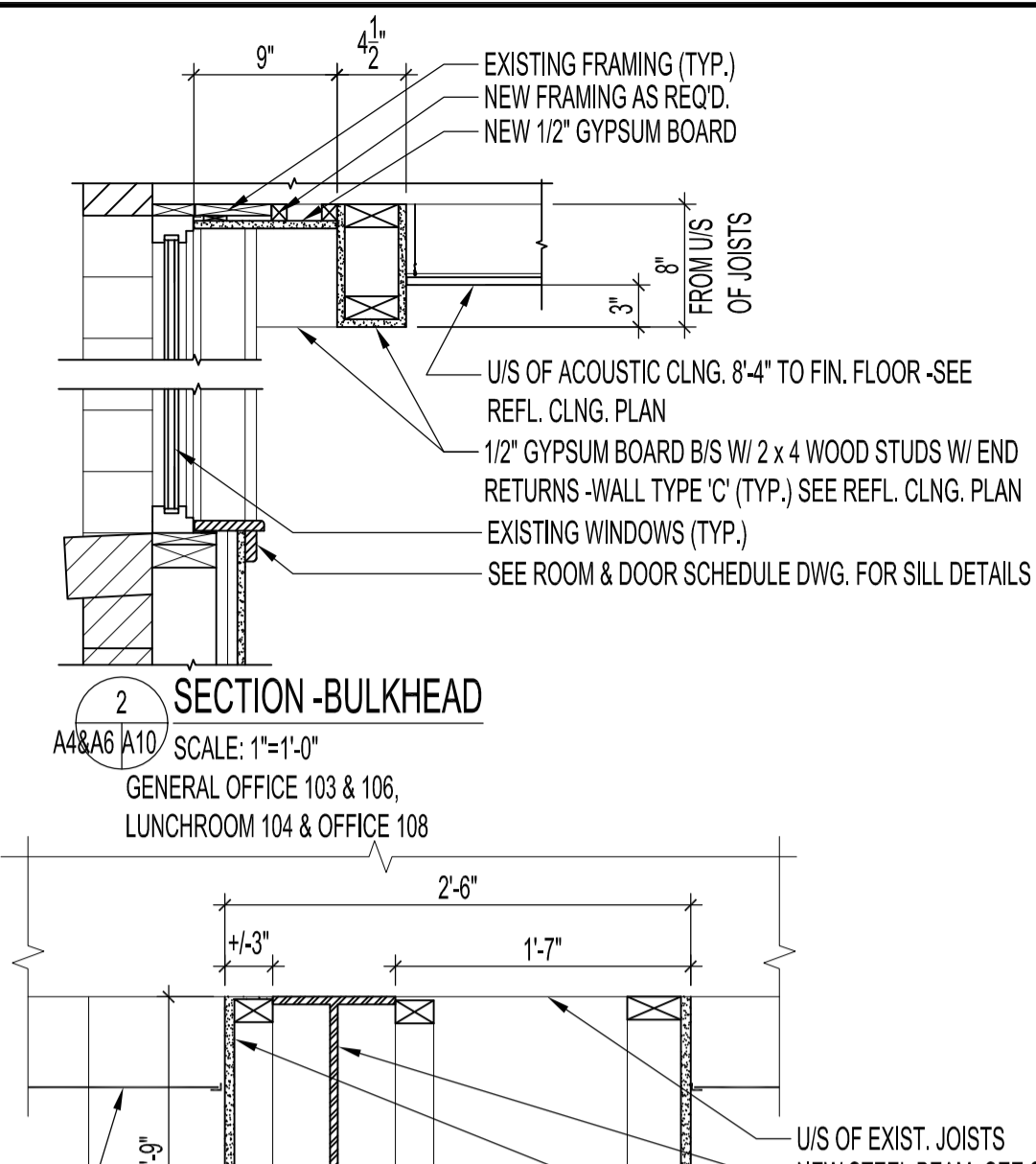
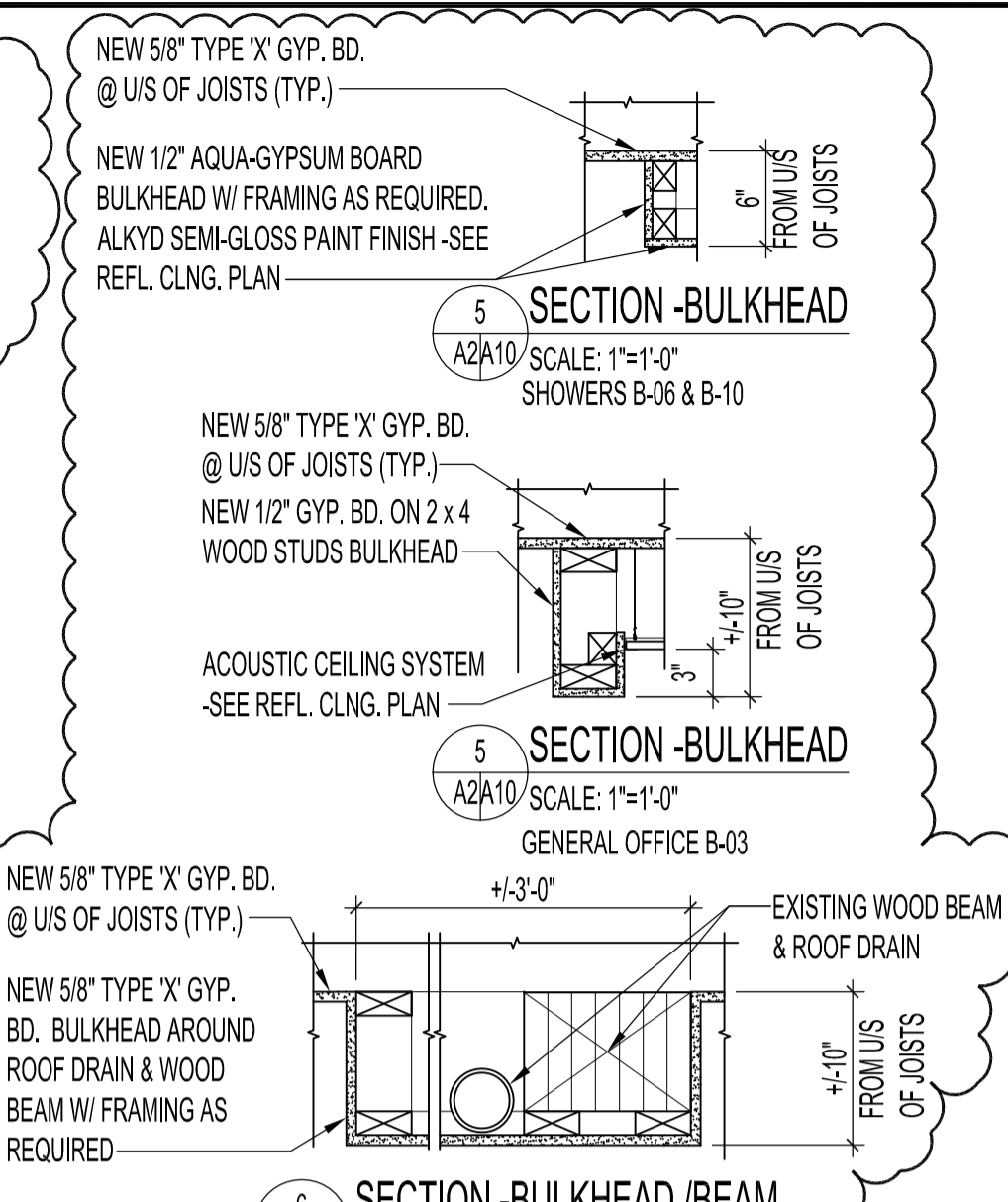
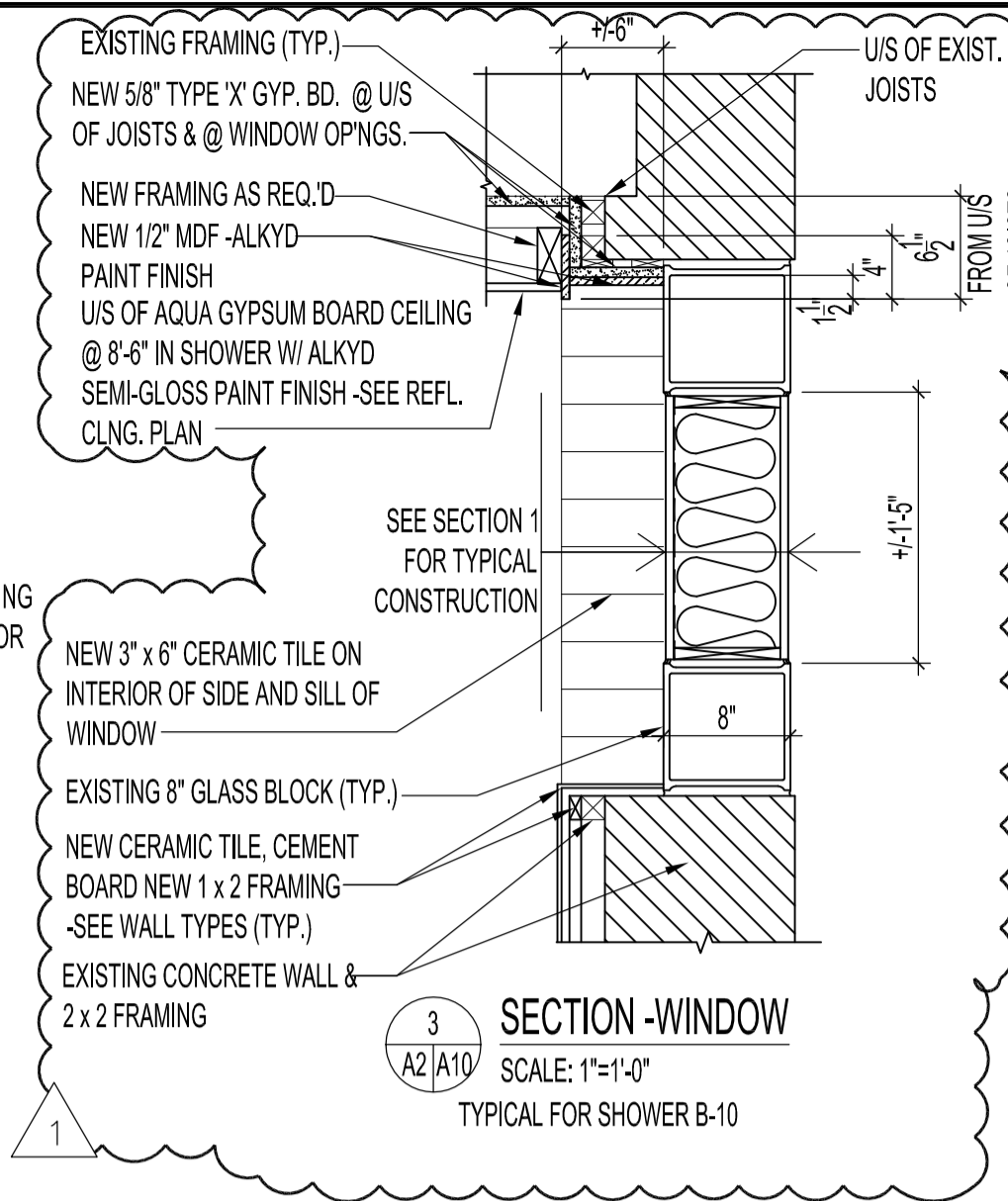
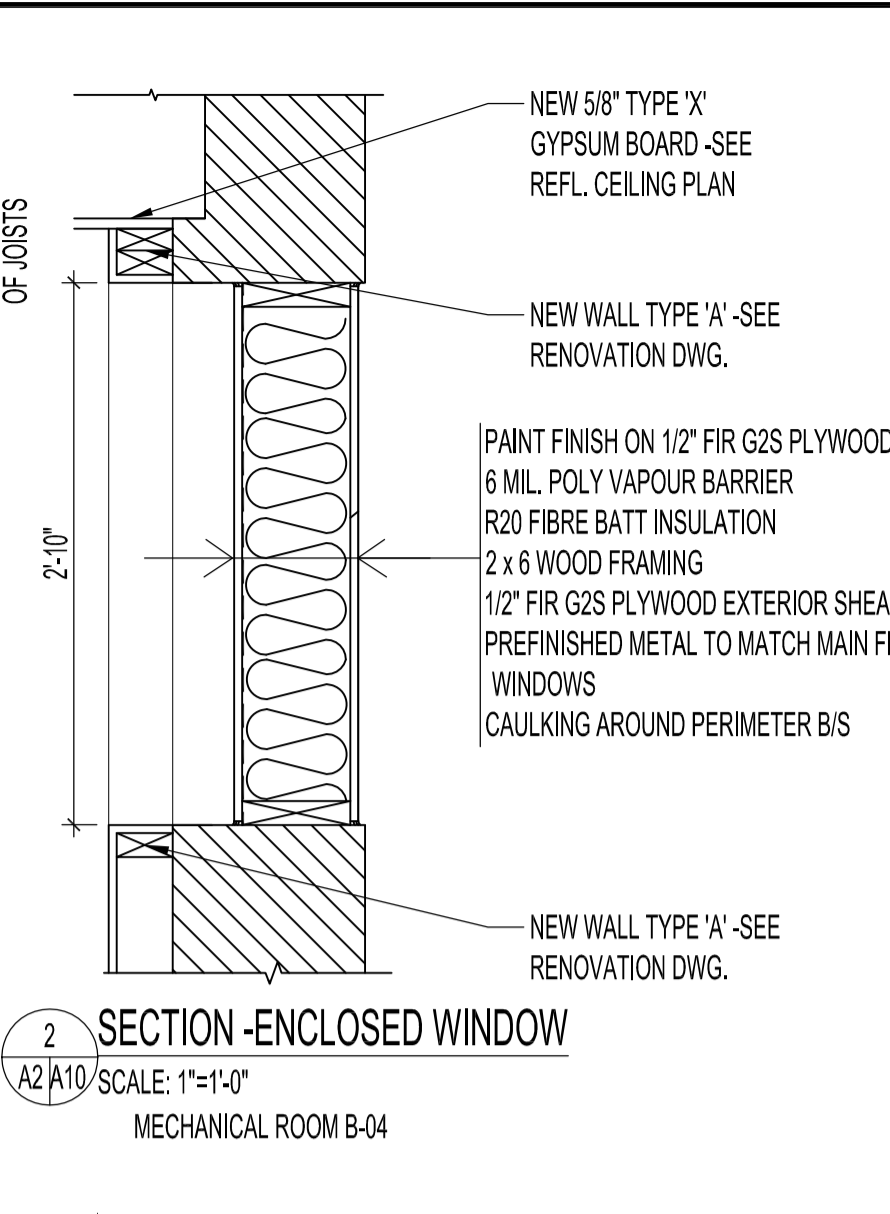
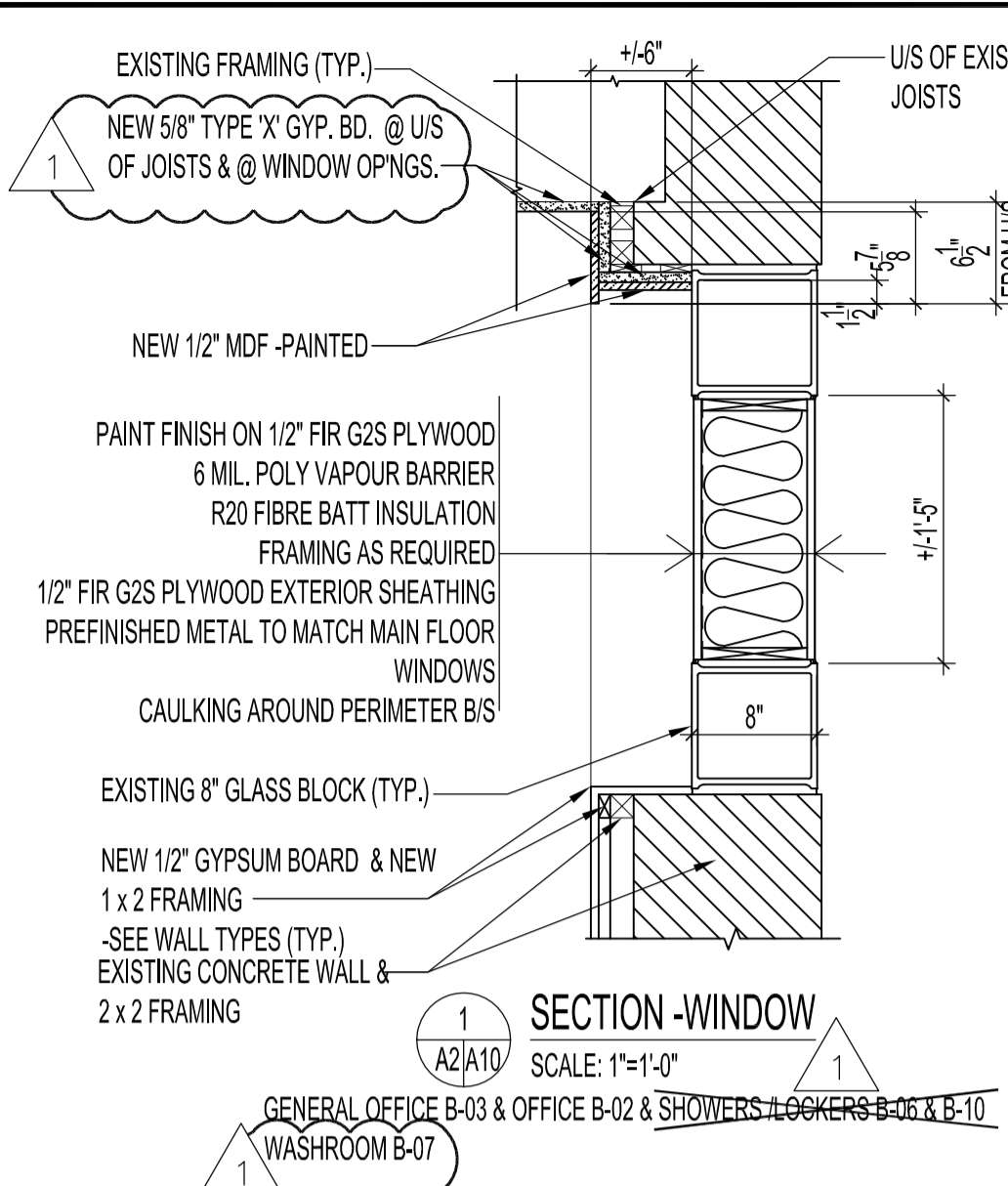

NOTES :
ALL EXTERIOR STAIR RAILINGS, WIRE MESH & COMPONENTS TO BE GALVANIZED METAL FINISH.
ALL INTERIOR RAILINGS & COMPONENTS TO BE PAINTED.

ORIGINAL STAMPED BY: R.K.FOK LI Arch.
DATE: 2007.11.15

SEE ADDENDUM 4 BID OPPORTUNITY 629-2007 MMK 2007.11.15
ADDED 5/8" TYPE 'X' GYPSUM BOARD TO WINDOW SECTIONS & US OF JOISTS
REVISED WINDOW SECTION #1
ADDED WINDOW SECTION IN SHOWER B-10
ADDED BULKHEAD SECTION IN SHOWERS B-06 & B-10
ADDED BULKHEAD SECTIONS IN OFFICE B-03

NO.	REVISION/DESCRIPTION	BY	DATE
SEALS			

DRAWN BY MMK **CHECKED BY** USER **APPROVED**
DATE: 2007.10.05

CITY OF WINNIPEG
PLANNING, PROPERTY & DEVELOPMENT DEPARTMENT
CIVIC ACCOMMODATIONS DIVISION
300 - 65 GARRY ST. R3C 4K4

PROJECT
COMMUNITY POLICE SERVICE CENTRE

1400 HENDERSON HIGHWAY

SHEET TITLE
BULKHEAD & COLUMN SECTIONS,
STAIR PLANS, ELEVATIONS & DETAILS

SCALE AS SHOWN **PROJECT NO.** 2004-023 **SHEET NO.** A10R1

DRAWING SHEET SIZE: A1 (841mm x 594mm) PLOT 1:1