

- NOTES:**
- LUG SCHEDULE DIMENSIONS IN MILLIMETERS.
  - PLATE SHALL CONFORM TO ASTM A283 GRADE D.
  - TIE ROD LUGS SHALL BE SPACED EQUALLY AROUND PIPE.
  - FILLET WELDS SHALL MEET THE MINIMUM REQUIREMENTS OF THE AISC SPECIFICATIONS EXCEPT AS FOLLOWS: FILLET WELDS SHALL BE 6mm MINIMUM EXCEPT WHEN WELDING 5mm PLATE WHERE THEY SHALL BE 5mm.
  - LUG TYPE I IS AS SHOWN IN DETAIL. LUG TYPE II HAS CONTINUOUS FRONT AND BACK PLATES AROUND PIPE.
  - THE MINIMUM PIPE WALL THICKNESSES SHOWN ARE TO ENSURE PROPER PERFORMANCE OF THE THRUST TIE LUG. PIPE WALL THICKNESSES GREATER THAN SHOWN IN THE TABLE MAY BE REQUIRED AND MAY BE SHOWN ELSEWHERE OR SPECIFIED ELSEWHERE TO RESIST INTERNAL PRESSURES.

LUG SCHEDULE										
ROD DIA	LUG TYPE	T	W	X	Y	Z	HB	E	HF	L
16	I	10	35	103	114	86	98	76	44	75
20	I	10	38	127	114	127	105	79	44	75
22	I	12	41	140	114	130	105	79	44	100
25	II	12	44	146	CONT	152	105	83	51	100
30	II	16	50	184	CONT	194	140	95	51	100
40	II	20	57	229	CONT	29	140	98	51	100
44	III	25	64	CONT	CONT	302	149	102	57	100
50	III	25	70	CONT	CONT	352	159	108	57	100

- NOTES:**
- ALL DIMENSIONS IN MILLIMETER, UNLESS OTHERWISE NOTED.

1 SPECIAL THRUST TIE FOR STEEL PIPE- LUG DETAIL AND SCHEDULE  
NTS

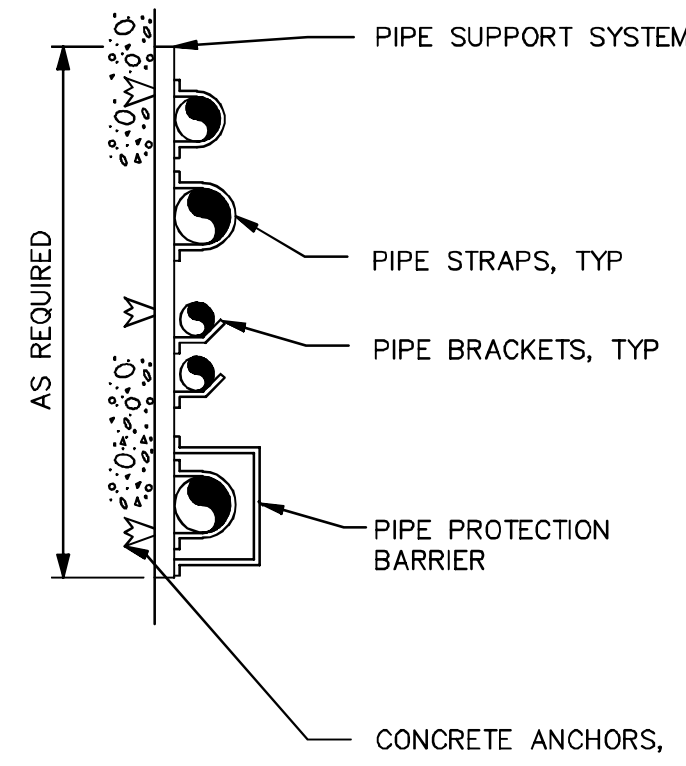

- NOTES:**
- ALL DIMENSIONS IN MILLIMETERS, UNLESS OTHERWISE NOTED.
  - PROVIDE PIPE PROTECTION BARRIER AS SPECIFIED.

2 STACKED PIPE WALL SYSTEM

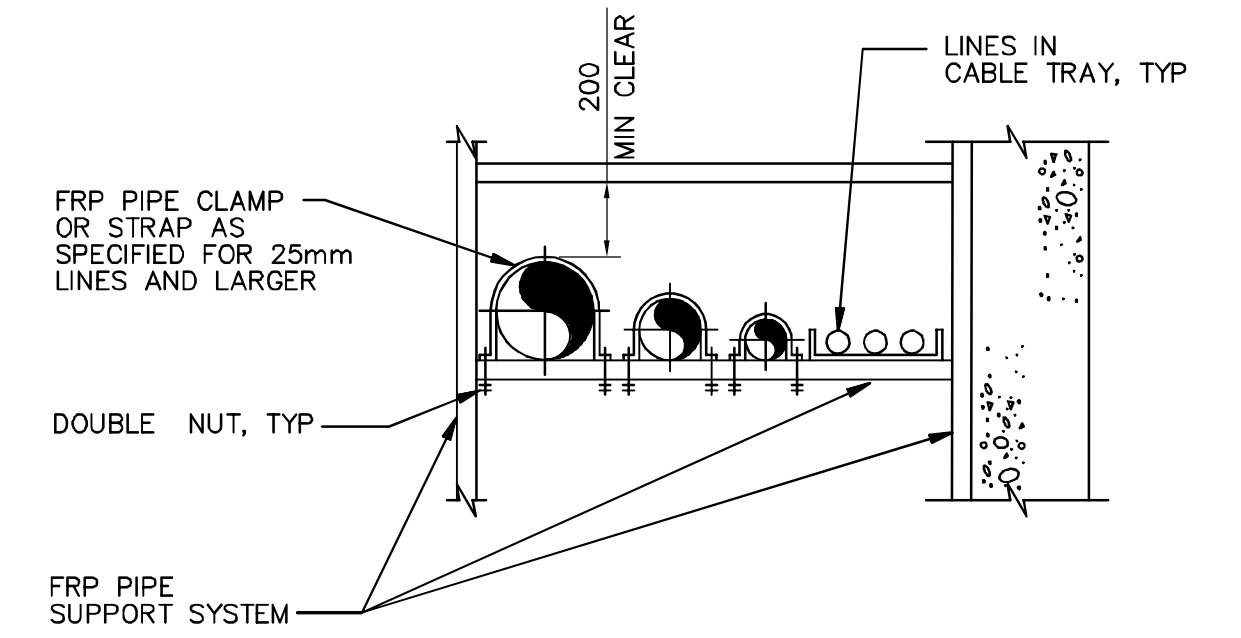

- NOTES:**
- ALL DIMENSIONS IN MILLIMETERS, UNLESS OTHERWISE NOTED.
  - PROVIDE PIPE PROTECTION BARRIER AS SPECIFIED.

3 GALLERY CHEMICAL LINES SUPPORT

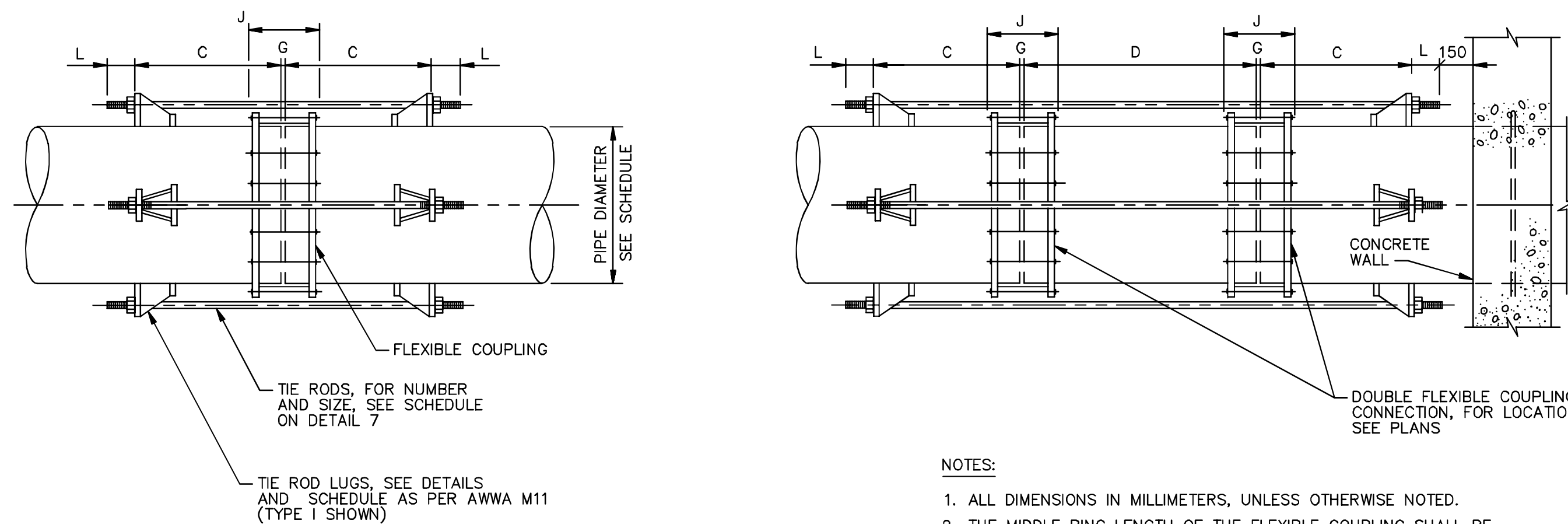

- NOTES:**
- ALL DIMENSIONS IN MILLIMETERS, UNLESS OTHERWISE NOTED.
  - THE MIDDLE RING LENGTH OF THE FLEXIBLE COUPLING SHALL BE AS SPECIFIED.
  - THE CONTRACTOR SHALL DETERMINE THE LENGTH "J" (COUPLING BOLT LENGTH) FROM MANUFACTURER'S CATALOGS USING THE SPECIFIED MIDDLE RING LENGTH.
  - "G" = MANUFACTURER'S RECOMMENDED SPACE BETWEEN ENDS OF PIPE.
  - "C" = J+Z+25mm, (ROUND THIS VALUE UP TO NEXT EVEN INCH), MINIMUM. (FOR Z DIMENSIONS, SEE LUG SCHEDULE.)
  - TIE ROD LENGTH = 2L+2C+G.

- NOTES:**
- ALL DIMENSIONS IN MILLIMETERS, UNLESS OTHERWISE NOTED.
  - THE MIDDLE RING LENGTH OF THE FLEXIBLE COUPLING SHALL BE AS SPECIFIED.
  - THE CONTRACTOR SHALL DETERMINE THE LENGTH "J" (COUPLING BOLT LENGTH) FROM MANUFACTURER'S CATALOGS USING THE SPECIFIED MIDDLE RING LENGTH.
  - G = MANUFACTURER'S RECOMMENDED SPACE BETWEEN ENDS OF PIPE.
  - C = J+Z+25mm, (ROUND THIS VALUE UP TO NEXT EVEN INCH), MINIMUM. (FOR Z DIMENSIONS, SEE LUG SCHEDULE.)
  - D = 2C+150mm
  - TIE ROD LENGTH = 2L+2C+2G+D.
  - SIMILAR, TO TYPICAL THRUST TIE DETAIL EXCEPT AS NOTED.

4 SPECIAL THRUST TIE FOR STEEL PIPE - ASSEMBLIES

\* SEE NOTES

TEST PRESSURE		170 kPa TIE RODS		340 kPa TIE RODS		690 kPa TIE RODS		1035 kPa TIE RODS		1550 kPa TIE RODS		2585 kPa TIE RODS	
PIPE DIA (mm)	MIN PIPE WALL THKS (mm)*	DIA (mm)	NO. REQD	DIA (mm)	NO. REQD	DIA (mm)	NO. REQD	DIA (mm)	NO. REQD	DIA (mm)	NO. REQD	DIA (mm)	NO. REQD
150	4.8	—	—	—	—	16	2	16	2	16	2	162	2
200	4.8	—	—	—	—	16	2	16	2	16	2	202	2
250	4.8	—	—	—	—	16	2	16	2	20	2	222	2
300	4.8	16	2	16	2	20	2	22	2	20	2	222	4
350	4.8	16	2	16	2	20	2	20	2	20	4	252	4
400	4.8	16	2	16	2	20	2	22	2	22	4	252	4
450	6.4	16	2	16	2	22	2	25	2	25	4	322	4
500	6.4	16	2	20	2	22	2	22	4	25	4	324	4
550	6.4	16	2	20	2	20	4	22	4	25	4	384	4
600	6.4	16	2	20	2	22	4	25	4	25	6	384	6
750	6.4	16	4	20	4	22	6	25	6	25	8	386	8
900	6.4	20	4	22	4	25	6	25	8	32	8	388	10
1050	6.4	20	4	25	4	25	8	32	8	38	8	448	10
1200	7.9	22	4	22	8	25	10	32	10	38	10	44	12
1350	7.9	20	6	22	8	25	12	32	12	38	12	44	14
1500	8.7	22	6	25	8	32	10	32	14	38	14	44	16
1800	9.5	22	8	25	10	32	12	38	14	44	14	51	18
1950	10.3	22	8	25	12	32	14	38	16	44	16	51	20
2100	11.1	22	10	32	10	38	14	44	14	44	18	51	22
2400	11.1	25	10	32	12	38	16	44	16	51	16	—	—
2700	12.7	25	12	32	12	44	12	51	14	51	22	—	—
3000	15.9	32	8	38	10	44	16	51	18	—	—	—	—
3300	18.3	32	6	44	10	44	18	51	22	—	—	—	—

- NOTES:**
- ALL DIMENSIONS IN MILLIMETERS, UNLESS OTHERWISE NOTED.
  - TIE RODS SHALL CONFORM TO ASTM A193 GRADE B7.
  - NUTS SHALL CONFORM TO ASTM A194 GRADE 2H.
  - TIE ROD NUTS SHALL BE TIGHTENED GRADUALLY AND EQUALLY IN STAGES TO PREVENT UNEVEN ALIGNMENT AND TO ALLOW EQUAL STRESS ON ALL TIE RODS UNDER PRESSURE. TIGHTEN UNTIL SNUG. THREADS SHALL PROTRUDE FROM NUTS. PEEN THREADS AFTER TIGHTENING NUTS.
  - CATHODIC PROTECTION FOR FLEXIBLE COUPLINGS REQUIRED WHERE NOTED ON DWGS OR IN THE SPECIFICATIONS.
  - CONTRACTOR SHALL USE DATA FOR ONLY THOSE PIPE SIZES AND TEST PRESSURES SPECIFIED IN THIS CONTRACT.
  - TIE RODS SHALL NOT BE ATTACHED TO A PIPE WHEN THE WALL THICKNESS IS LESS THAN THE MINIMUM SHOWN ON THE TIE ROD SCHEDULE.
  - THE MINIMUM PIPE WALL THICKNESSES SHOWN ARE TO ENSURE PROPER PERFORMANCE OF THE THRUST TIE LUG. PIPE WALL THICKNESSES GREATER THAN SHOWN IN THE TABLE MAY BE REQUIRED AND MAY BE SHOWN ELSEWHERE OR SPECIFIED ELSEWHERE TO RESIST INTERNAL PRESSURES.

5 SPECIAL THRUST TIE FOR STEEL PIPE - TIE ROD SCHEDULE

FOR INFORMATION ONLY - ISSUED WITH BID OPPORTUNITY 792-2006 - ADDENDUM 8

**APEGM**  
Certificate of Authorization  
CH2M HILL Canada Ltd.  
No. 1441 Expiry: April 30, 2007

B.M. ELEV.					
DESIGNED BY	TB	CHECKED BY	LS	ENGINEER'S SEAL	
DRAWN BY	P SINGH	APPROVED BY	AHL	ORIGINAL SIGNED BY	P. WOBMA
SCALE:	NTS	RELEASED FOR CONSTRUCTION BY:	R. SOROKOWSKI	DATE	2006/03/29
DATE	2005/12/02	DATE	2006/03/29	CONSULTANT DRAWING NO.	WB-M0462
01 ISSUED FOR CONSTRUCTION	06/07/28	TB			
00 ISSUED FOR TENDER	06/03/29	TB			
NO. REVISIONS	DATE	BY			

**CH2MHILL** **EarthTech**

**Frederickson Cooper ARCHITECTS**

**THE CITY OF WINNIPEG WATER AND WASTE DEPARTMENT ENGINEERING DIVISION**

WATER TREATMENT PLANT MAIN BUILDING MECHANICAL AND ELECTRICAL

PROCESS MECHANICAL

STANDARD DETAILS

CITY FILE NUMBER

SHEET OF

CITY DRAWING NUMBER

1-0601B-A-M0462-001-010