

8 SECTION
WS-S0203 1:75

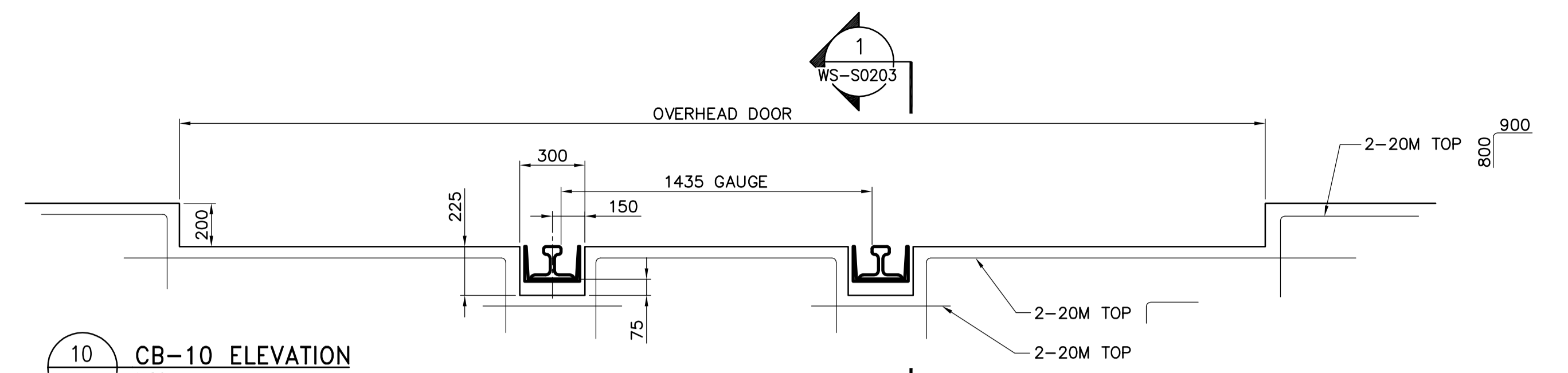

10 CB-10 ELEVATION
WS-S0100 1:20

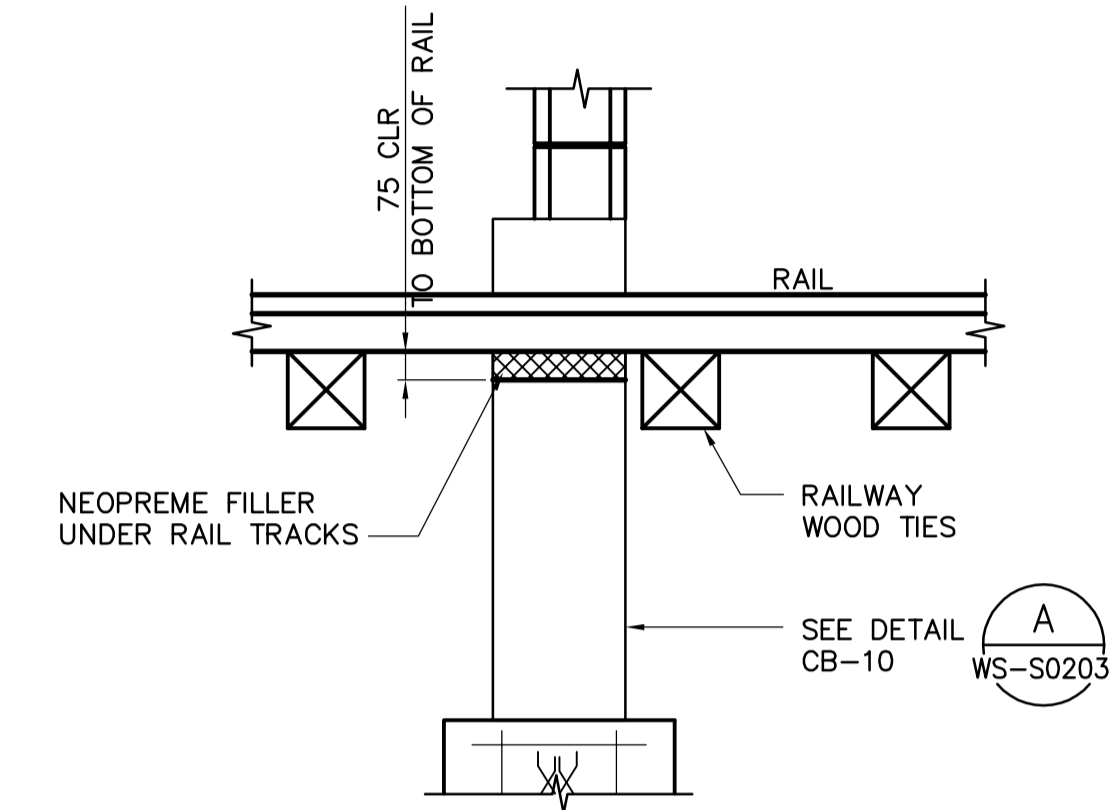

1 SECTION
WS-S0203 1:20

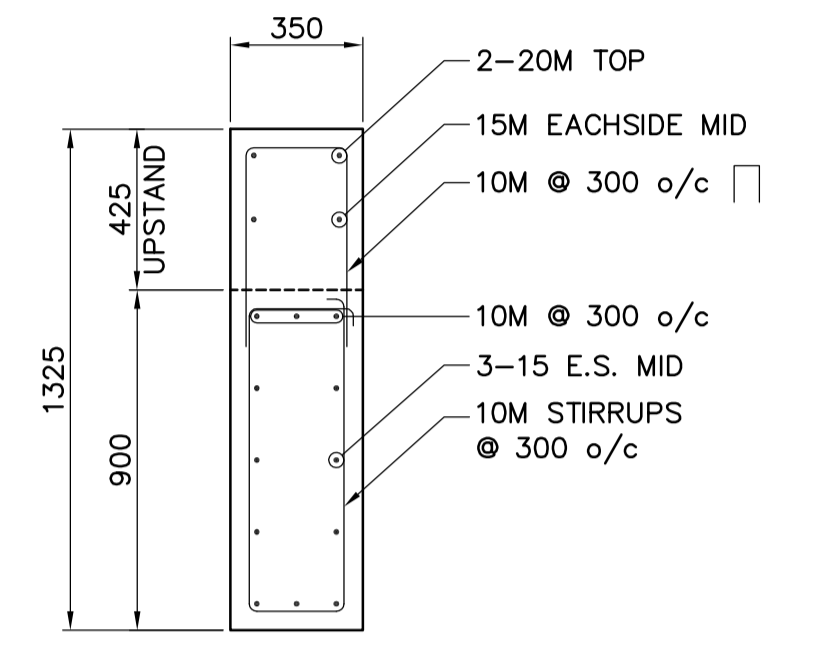

A CB-10 DETAIL
WS-S0203 1:20

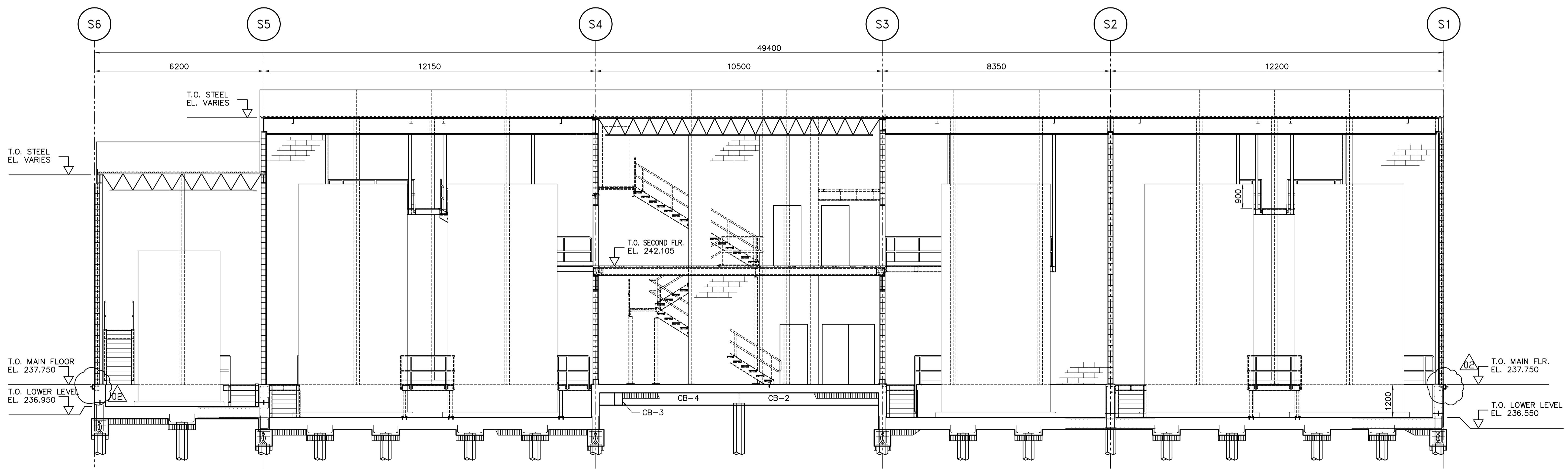

9 SECTION
WS-S0203 1:75

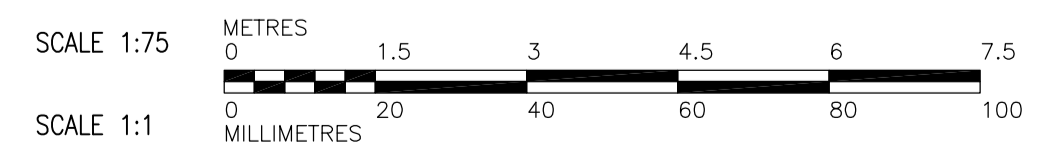

B.M. ELEV.		CH2M HILL Frederickson Cooper ARCHITECTS		ENGINEER'S SEAL ORIGINAL SIGNED BY A. POCHANART 2007/01/31		THE CITY OF WINNIPEG WATER AND WASTE DEPARTMENT ENGINEERING DIVISION	
DESIGNED BY	ARA	CHECKED BY	AP	CONSULTANT DRAWING NO. WS-S0203		WATER TREATMENT PLANT BULK CHEMICAL BUILDING SODIUM HYPOCHLORITE AND CHEMICAL STORAGE BUILDING	
DRAWN BY	WDB	APPROVED BY	AHL	RELEASED FOR CONSTRUCTION BY: R. SOROKOWSKI		CITY FILE NUMBER SHEET OF	
SCALE:	AS NOTED	DATE	2007/01/22	DATE	2007/01/31	CITY DRAWING NUMBER 1-06019-A-90203-001-02D	
NO. REVISIONS	DATE	BY		DATE		STRUCTURAL BUILDING SECTIONS	