

NOTE: CHAINAGES SHOWN ARE ALONG N R OF GORDON AVENUE

GORDON AVENUE

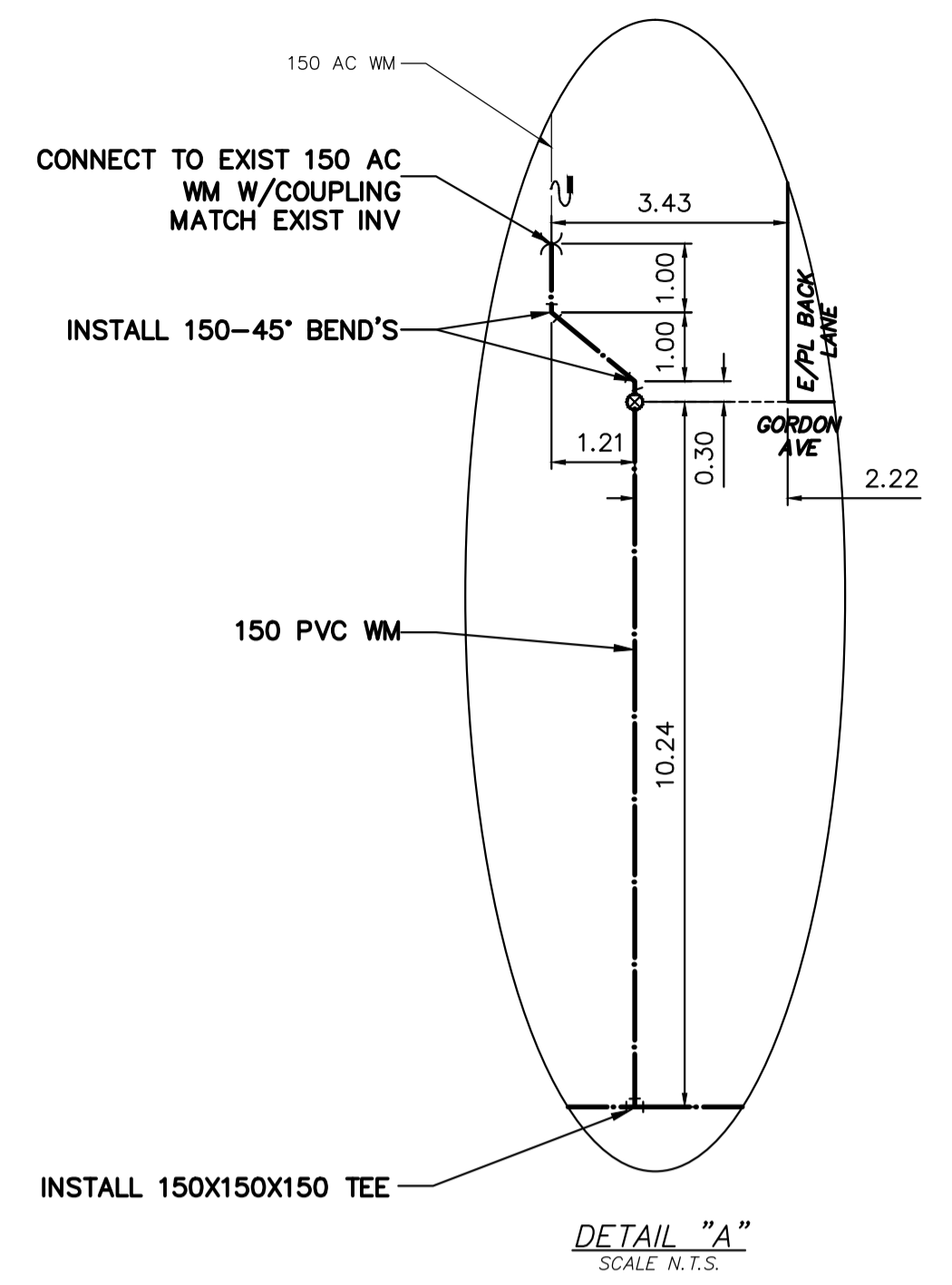

WATER SERVICE INFORMATION

ADDRESS	SIZE (mm) MATERIAL (STREET)	SIZE (mm) MATERIAL (PROP.)	SHORT & LONG MEASUREMENT	LINEAR DISTANCE CORP LOCATION	REMARKS
241 GORDON AVE RESIDENTIAL	20 CU	20	3.66 WEL HSE	0.1 W OF S/C	RECONNECT SERVICE
242 GORDON AVE RESIDENTIAL	20 CU	12 LEAD	48.774 WWL BACK LANE #1	0.1 W OF S/C	RENEW TO R W/20 CU WYED W/244
244 GORDON AVE RESIDENTIAL	20 CU	20	1.49 EEL HSE	OPP OF S/C	RENEW TO R W/20 CU WYED W/242
245 GORDON AVE RESIDENTIAL	20 CU	20	39.140 EEL BACK LANE #2	OPP OF S/C	RECONNECT SERVICE
246 GORDON AVE RESIDENTIAL	20 CU	20	0.34 WWL HSE	OPP OF S/C	RECONNECT SERVICE
247 GORDON AVE RESIDENTIAL	20 CU	20	39.140 EEL BACK LANE #2	OPP OF S/C	RECONNECT SERVICE
248 GORDON AVE RESIDENTIAL	20 CU	20	1.05 EWL HSE	OPP OF S/C	RECONNECT SERVICE
249 GORDON AVE RESIDENTIAL	20 CU	20	41.625 WWL BACK LANE #1	OPP OF S/C	RECONNECT SERVICE
251 GORDON AVE RESIDENTIAL	20 CU	20	4.65 EWL HSE	OPP OF S/C	RECONNECT SERVICE
253 GORDON AVE RESIDENTIAL	20 CU	20	51.570 EEL BACK LANE #2	OPP OF S/C	RECONNECT SERVICE
252 GORDON AVE RESIDENTIAL	20 CU	20	3.28 EWL BLDG	OPP OF S/C	RECONNECT SERVICE
254 GORDON AVE RESIDENTIAL	20 CU	20	31.000 WWL BACK LANE #1	OPP OF S/C	RECONNECT SERVICE
255 GORDON AVE RESIDENTIAL	20 CU	20	0.10 EWL BLDG	OPP OF S/C	RECONNECT SERVICE
256 GORDON AVE RESIDENTIAL	20 CU	20	54.330 EEL BACK LANE #2	OPP OF S/C	RECONNECT SERVICE
257 GORDON AVE RESIDENTIAL	20 CU	20	2.98 EWL BLDG	OPP OF S/C	RECONNECT SERVICE
258 GORDON AVE RESIDENTIAL	20 CU	20	22.016 WWL BACK LANE #1	OPP OF S/C	RECONNECT SERVICE
259 GORDON AVE RESIDENTIAL	20 CU	12	2.96 EWL BLDG	OPP OF S/C	RECONNECT SERVICE
261 GORDON AVE RESIDENTIAL	20 CU	12	12.789 WWL BACK LANE #1	OPP OF S/C	RECONNECT SERVICE
262 GORDON AVE RESIDENTIAL	20 CU	12	1.27 EWL BLDG	OPP OF S/C	RECONNECT SERVICE
263 GORDON AVE RESIDENTIAL	20 CU	12	67.800 EEL BACK LANE #2	OPP OF S/C	RECONNECT SERVICE
264 GORDON AVE RESIDENTIAL	20 CU	12	5.43 EWL BLDG	OPP OF S/C	RECONNECT SERVICE
265 GORDON AVE RESIDENTIAL	20 CU	12	0.932 WWL BACK LANE #1	OPP OF S/C	RECONNECT SERVICE
266 GORDON AVE RESIDENTIAL	20 CU	12	2.04 EWL BLDG	OPP OF S/C	RECONNECT SERVICE
267 GORDON AVE RESIDENTIAL	20 CU	12	77.250 EEL BACK LANE #2	OPP OF S/C	RECONNECT SERVICE
268 GORDON AVE RESIDENTIAL	20 CU	12	3.46 EWL BLDG	OPP OF S/C	RECONNECT SERVICE
269 GORDON AVE RESIDENTIAL	20 CU	12	101.680 EEL BACK LANE #2	OPP OF S/C	RECONNECT SERVICE
270 GORDON AVE RESIDENTIAL	20 CU	12	5.53 EWL BLDG	OPP OF S/C	RECONNECT SERVICE
271 GORDON AVE RESIDENTIAL	20 CU	12	6.100 EEL BACK LANE #1	OPP OF S/C	RECONNECT SERVICE
272 GORDON AVE RESIDENTIAL	20 CU	20	2.46 EWL HSE	OPP OF S/C	RECONNECT SERVICE
273 GORDON AVE RESIDENTIAL	20 CU	12	13.293 EEL BACK LANE #1	OPP OF S/C	RECONNECT SERVICE

\* SERVICES TO BE RENEWED TO R. ALL OTHERS TO BE RECONNECTED

MATCHLINE 2+10.00 SEE DWG D-16870

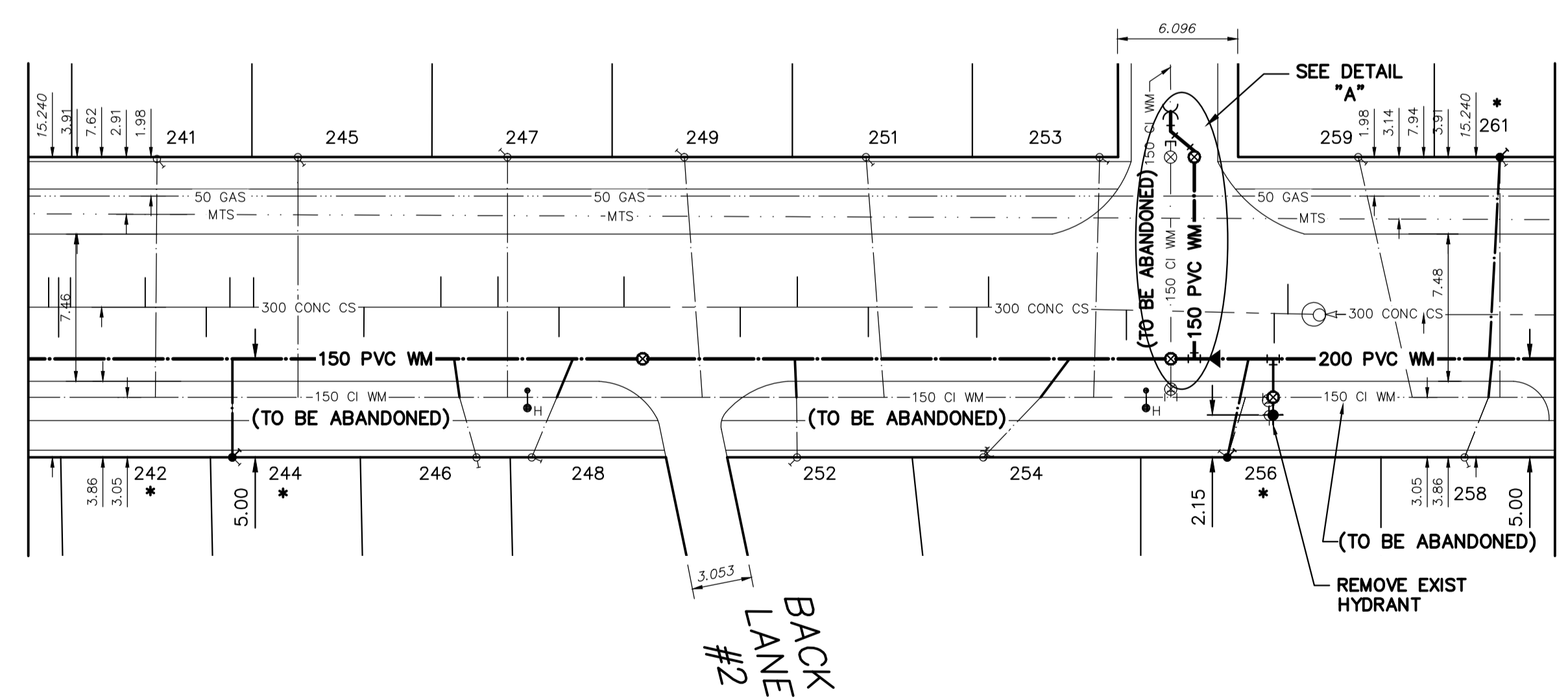

MATCHLINE 2+87.50 SEE DWG D-16872

FOR INDEX SEE D-16868

NOTE: ALL VALVES TO BE INSTALLED COUNTERCLOCKWISE TO CLOSE

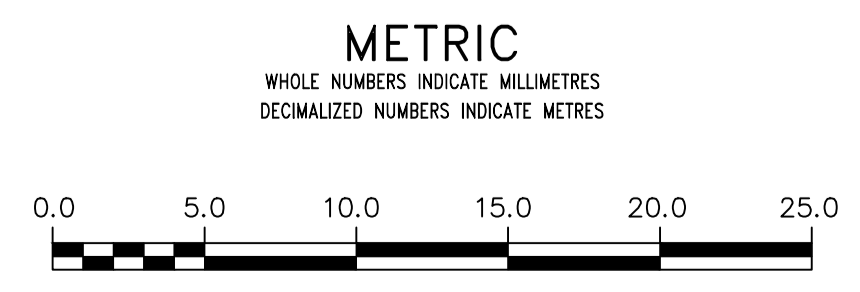

**WARNING**  
IF POWER EQUIPMENT OR EXPLOSIVES ARE TO BE USED FOR EXCAVATION ON THIS PROJECT THE CONTRACTOR MUST:  
1) NOTIFY THE GAS COMPANY OF THE PROPOSED LOCATION OF EXCAVATION.  
2) TAKE PRECAUTION TO AVOID DAMAGE TO GAS COMPANY INSTALLATIONS.  
SEE PROVINCIAL REGULATION 210/72 FOR DETAILS

**LOCATION APPROVED**  
UNDERGROUND STRUCTURES  
SUPV. U/G STRUCTURES COMMITTEE DATE  
NOTE:  
LOCATION OF UNDERGROUND STRUCTURES AS SHOWN ARE BASED ON THE BEST INFORMATION AVAILABLE BUT NO GUARANTEE IS GIVEN THAT ALL EXISTING UTILITIES ARE SHOWN OR THAT THE GIVEN LOCATIONS ARE EXACT. CONFIRMATION OF EXISTENCE AND EXACT LOCATION OF ALL SERVICES MUST BE OBTAINED FROM THE INDIVIDUAL UTILITIES BEFORE PROCEEDING WITH CONSTRUCTION.

VERTICAL DATUM: CGVD28 (HT2.0 Geoid)  
HORIZONTAL DATUM: NAD83 (June 1990), Zone 14

NO.	REVISIONS	DATE	BY

DESIGNED BY	JB	CHECKED BY	SC
DRAWN BY	AOM	APPROVED BY	SC
SCALE:	HORIZONTAL 1:250 VERTICAL 1:50		
DATE	2024 04 09	RELEASED FOR CONSTRUCTION	
PLOT DATE:	2024 04 09	DATE	

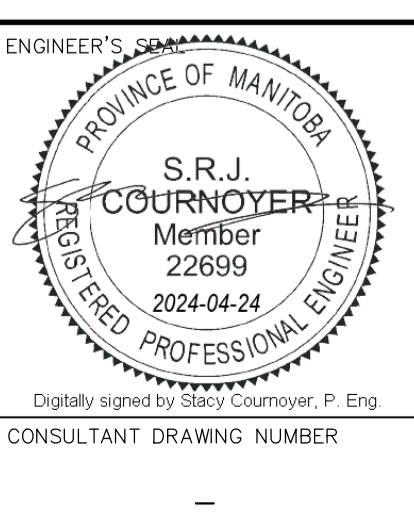

**THE CITY OF WINNIPEG**  
WATER AND WASTE DEPARTMENT  
ENGINEERING DIVISION

2024 WATER MAIN RENEWALS  
CONTRACT #5  
GORDON AVENUE  
110.0 E OF BRAZIER STREET TO  
187.5 E OF BRAZIER STREET

SHEET 4 OF 13  
CITY DRAWING NUMBER  
D-16871

FILE PATH: R:\DRAWINGS\WATER\RENEWAL\2024 RENEWALS\Cont 5\Construction Dwg\5  
FILE NAME: GORDON AVE.dwg