

1 LUMBER EDGING WITH FABRIC
Scale: 1:5

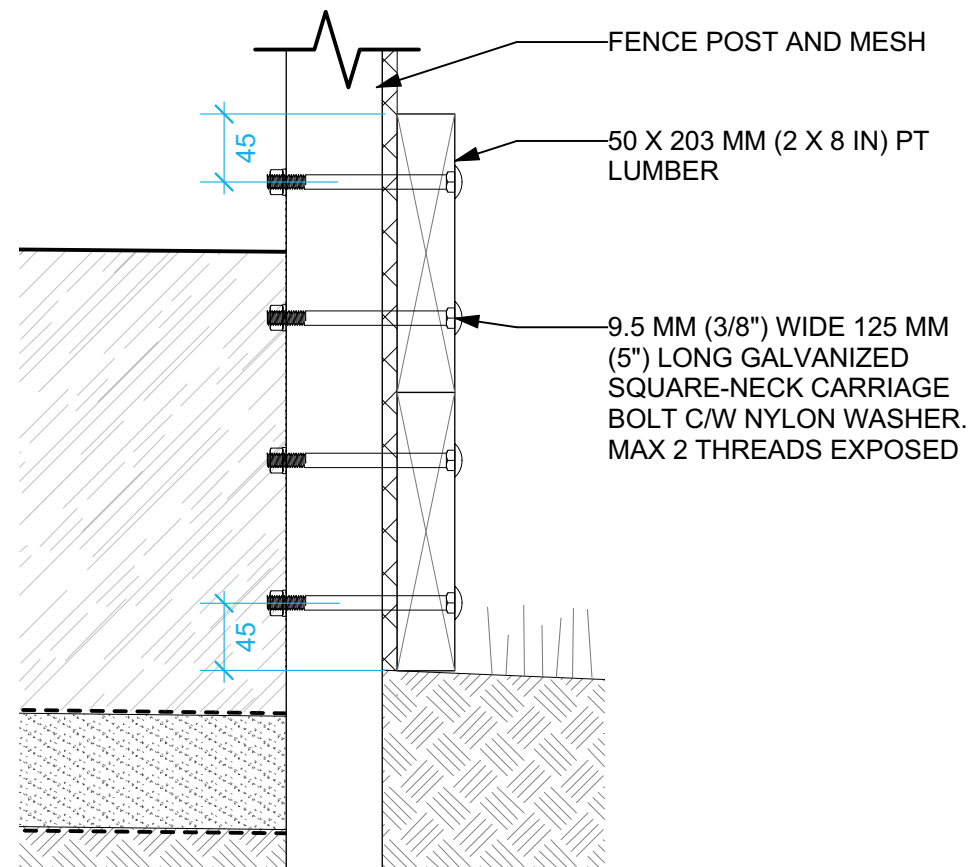

2 LUMBER EDGING TO FENCE ATTACHMENT
Scale: 1:5

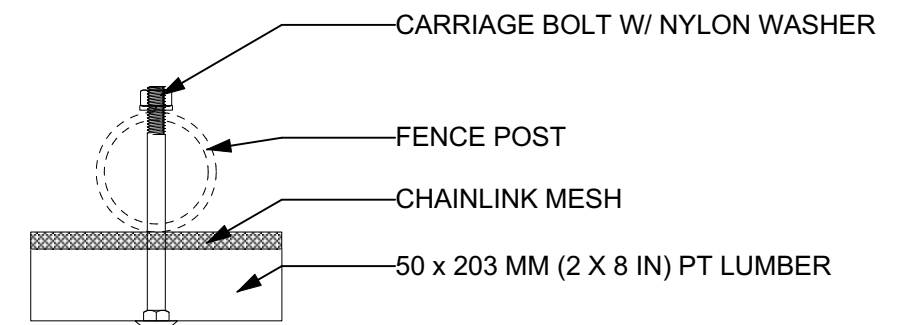

3 LUMBER EDGING TO FENCE ATTACHMENT 2
Scale: 1:4

GENERAL NOTES

1. ALL WORK TO CONFORM TO CURRENT CITY OF WINNIPEG STANDARD CONSTRUCTION SPECIFICATIONS AND DETAILS UNLESS OTHERWISE NOTED.
2. DIMENSIONS ARE IN MILLIMETERS UNLESS OTHERWISE NOTED.
3. DO NOT SCALE DRAWINGS.

CONTRACTOR TO CONFIRM ALL DIMENSIONS AND REPORT ANY DISCREPANCIES TO CONTRACT ADMINISTRATOR PRIOR TO CONSTRUCTION. LOCATION OF UNDERGROUND STRUCTURES AS SHOWN ARE BASED ON THE BEST INFORMATION AVAILABLE BUT NO GUARANTEE IS GIVEN THAT ALL EXISTING UTILITIES ARE SHOWN OR THAT THE GIVEN LOCATIONS ARE EXACT. CONFIRMATION OF EXISTENCE AND EXACT LOCATION OF ALL SERVICES MUST BE OBTAINED FROM THE INDIVIDUAL UTILITIES BEFORE PROCEEDING WITH CONSTRUCTION.



THE CITY OF WINNIPEG
Planning, Property and Development Department
Planning and Land Use Division
Unit 15 - 30 Fort Street, Winnipeg, MB, (R3C 4X5)

DESIGNED BY	TB	CHECKED BY	
DRAWN BY	TB	APPROVED BY	
HORIZ. SCALE	AS NOTED		
VERT. SCALE	AS NOTED		
DATE	FEBRUARY 2023		

MANAGER, PARK AND OPEN SPACES	DATE
MANAGER, PLANNING AND LAND USE DIVISION	DATE

DRAWING TITLE Norwood Community Centre Playground Redevelopment DETAILS
SITE ADDRESS 87 Walmer Street

DRAWING NO. N.15-H-6
BID OPPORTUNITY NO. 27-2024